

RF-215

PROFESSIONAL VEHICLE SECURITY SYSTEM

INSTALLATION MANUAL **(For Authorized Dealers Only)**

THIS PRODUCT IS DESIGNED FOR PROFESIONAL INSTALLATION ONLY

WIRING DIAGRAM

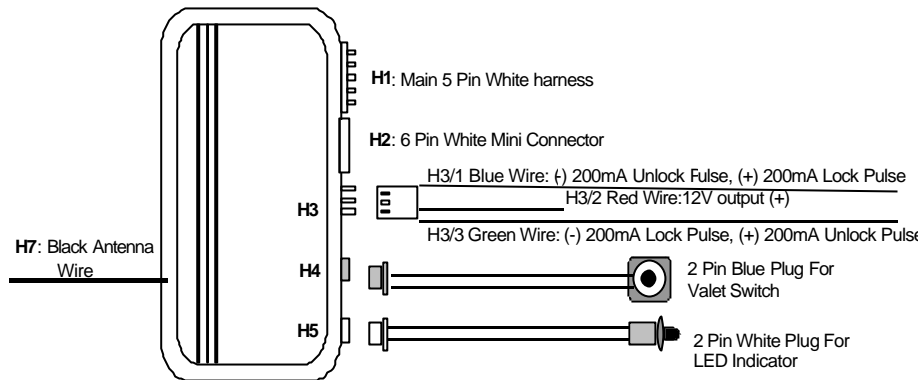

H1: MAIN 5 PIN WIRE HARNESS:

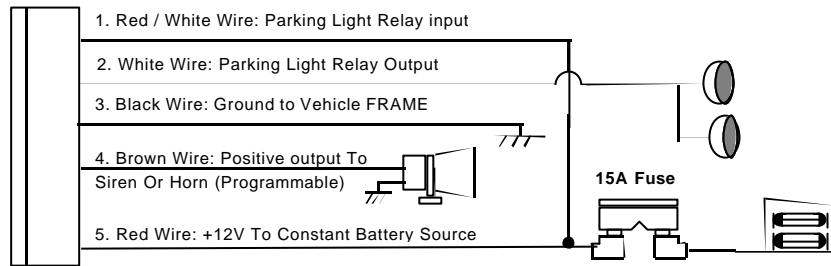

H2: 6 PIN MINI CONNECTOR WIRE HARNESS:

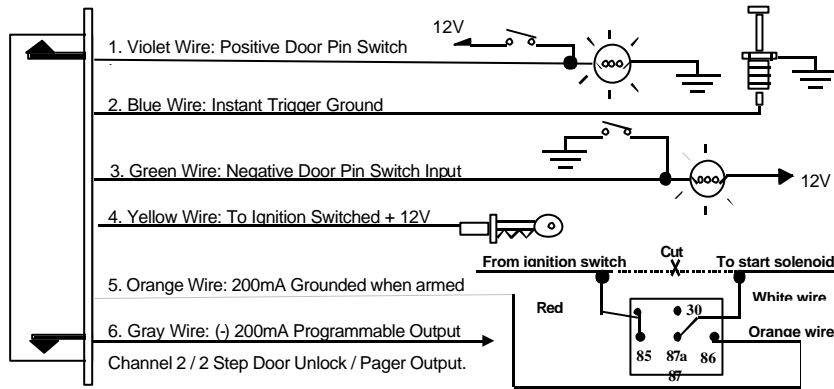

DOOR LOCK DIAGRAMS

5-WIRE ALTERNATING DOOR LOCK

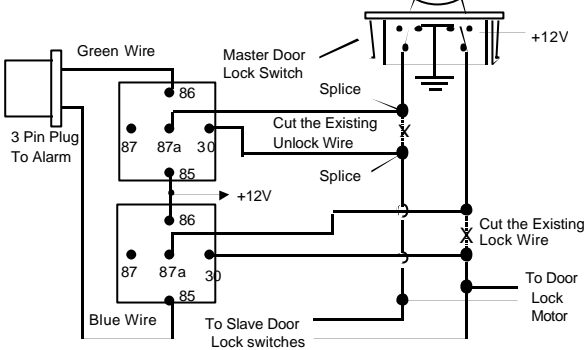

VACUUM OPERATED CENTRAL LOCKING

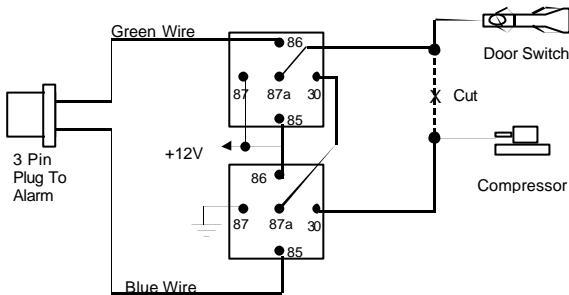

VACUUM OPERATED DOOR LOCKING SYSTEM:

TYPICAL OF MERCEDES BENZ AND AUDI.

Locate the wire under the driver's kick panel. Use the voltmeter connecting to ground, verify that you have the correct wire with the doors unlocked, the voltmeter will receive "12 volts". Lock the doors and the voltmeter will read "0 volt". Move the alligator clip to +12V and the voltmeter will receive "12 volts". Cut this wire and make connections. Be sure to program door lock timer to 3 seconds.(See Feature II – 1 Programming.)

2 STEP DOOR UNLOCK WIRE CONNECTION FOR GROUND SWITCHED DOOR LOCKS

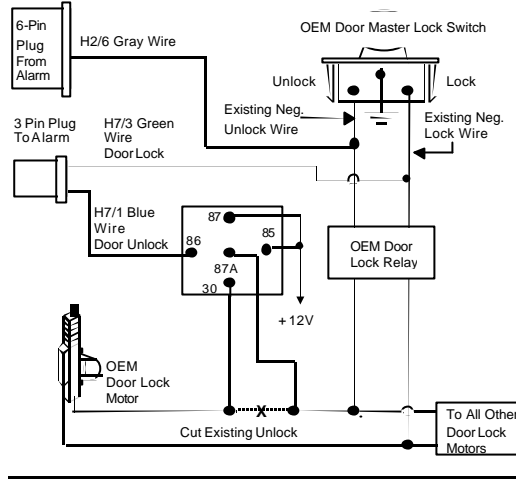

2 STEP DOOR UNLOCK WIRE CONNECTION FOR POSITIVE SWITCHED DOOR LOCKS

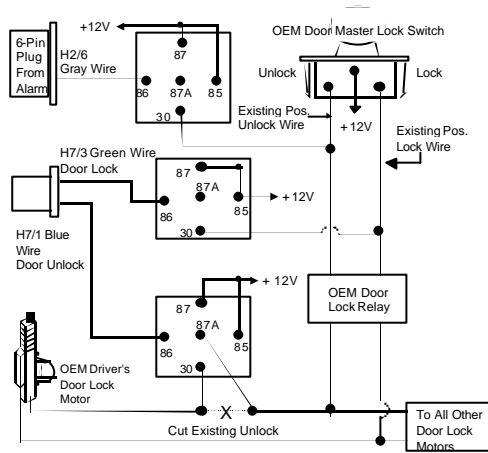

STARTER DISABLE

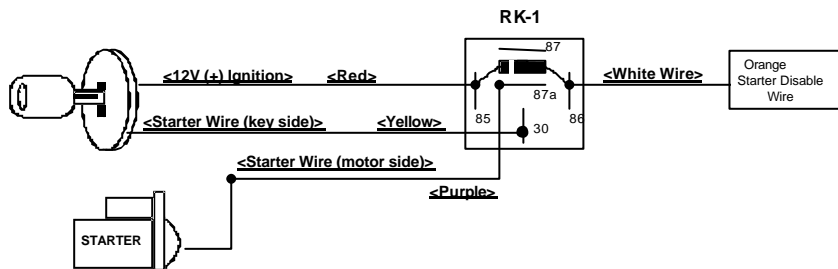

PROGRAMMING

PROGRAMMING TRANSMITTER:

Enter:

1. Turn the Ignition 'switch ' OFF/ON' 3 TIMES and stay in ON position. Within 15 seconds,

2. Push the Valet switch 3 times and hold in on the 3rd push; when a long chirp is heard then release the valet switch. You are now in the Transmitter programming mode.

Program:



1. Press any button on the first transmitter until the siren responds with a confirming chirp; the first transmitter is now programmed.
2. Press any button on the second transmitter until the siren responds with a confirming chirp; the second transmitter is now programmed.
3. Apply the same procedure to program any 3rd and 4th transmitters.

Exit: Turn Ignition to 'OFF' position, or leave it for 15 seconds. 3 long chirps will confirm exit.

Note: If more than 4 transmitters programmed, the system will only keep the last 4 transmitters.

ALARM FEATURE "I" PRORAMMING:

1. Turn the Ignition 'switch ' ON/OFF' 3 TIMES and stay in OFF position.
2. Push the Valet switch 2 times and hold in on the 2nd push; when a long chirp is heard then release the valet switch. You are now in the Alarm feature 'I' programming mode.
3. Press the transmitter button corresponding to the feature you want to program.
 - a. *The factory default settings is always [1] LED flash, [1] chirp.*
4. Depress the transmitter button again to change the feature. Simply keep pressing the transmitter button again until the module advances to your desired setting.



Press Transmitter Button	One Chirp / LED one pulse Factory Default Setting	Two Chirps / LED two pulse
1 	Chirps on	Chirps off
2 	Automatic Rearm On	Automatic Rearm Off
3 	With Door Ajar error chirp	Bypass Door Ajar error chirp.

Exit: Turn Ignition to 'ON' position, or leave it for 15 seconds. 3 long chirps will confirm exit.

ALARM FEATURE "II" PRORAMMING:

- 1 Turn the Ignition 'switch ' ON/OFF' 3 TIMES and stay in OFF position.
- 2 Push the Valet switch 4 times and hold in on the 4th push; when a long chirp is heard, then release the valet switch. You are now in the Alarm feature 'II' programming mode.
- 3 Press the transmitter button corresponding to the feature you want to program.



Press Transmitter Button	One Chirp / LED one pulse Factory Default Setting	Two Chirps / LED two pulse	Three Chirps / LED three pulse
1 	0.9-second Door lock pulses.	3.0-second Door lock pulse.	Double pulse unlock

2 	Active arming	Passive arming without passive door locking	Passive arming with passive door locking.
3 	Ignition controlled door locks & unlocks	Without ignition controlled door locks & unlocks	

Exit: Turn Ignition to 'ON' position, or leave it for 15 seconds. 3 long chirps will confirm exit.

ALARM FEATURE "III" PRORAMMING:

- 1 Turn the Ignition 'switch ' ON/OFF' 3 TIMES and stay in OFF position.
- 2 Push the Valet switch 6 times and hold in on the 6th push; when a long chirp is heard, then release the valet switch. You are now in the Alarm feature ' III' programming mode.
- 3 Press the transmitter button corresponding to the feature you want to program.

Press Transmitter Button	One Chirp / LED one pulse Factory Default Setting	Two Chirps / LED two pulse	Three Chirps / LED three pulse
1 	H1/4 Brown Wire = Siren Output	H1/4 Brown Wire = Horn Output	
2 	H2/6 Gray Wire = Trunk (Channel 2) Output	H2/6 Gray Wire = Two Step Door Unlock Output	H2/6 Gray Wire = Pager Output
3 	Car Jacking Off	Car Jacking On	

Exit: Turn Ignition to 'ON' position, or leave it for 15 seconds. 3 long chirps will confirm exit





ALARM FEATURE "IV" PROGRAMMING:

1. Turn the Ignition 'switch ' ON/OFF' 3 TIMES and stay in OFF position.
2. Push the Valet switch 8 times and hold in on the 8th push until FOUR chirps with a long chirp is heard then release the valet switch. You are now in the Alarm feature ' IV' programming mode.
3. Press and hold the transmitter  button for two seconds to enter shock sensor program mode.

Press Transmitter Button	One Chirp / LED one pulse Factory Default Setting	Two Chirps / LED two pulse
1 		Shock Sensor Program Mode

ADJUST AND TEST THE SENSITIVITY LEVEL OF THE SHOCK SENSOR

1. Turn the Ignition 'switch ' ON/OFF' 3 TIMES and stay in OFF position.
2. Push the Valet switch 8 times and holding in on the 8th push until four chirps with a long chirp is heard then release the valet switch. You are now in the Alarm feature 'Shock Sensor' programming mode.

3. Press and hold  button for 2 seconds. One long siren chirp to indicates the unit is ready to accept adjustments of the shock sensor.
 4. Press  button on the transmitter once. This will **decrease** sensitivity level by one, each time the button is pushed, a decrease is made the siren/horn chirp will respond with [1] chirp, while 2 chirp indicates the minimum of sensitivity.
 5. Press  button on the transmitter once. This will increase sensitivity level by one, each time an increase is made the siren/horn chirp will respond with [1] chirp, while 2 chirp indicates the maximum sensitivity.
 6. Hit the bumper or strong metal part of the vehicle to test the threshold level of the sensor.
 - a). Activate the warn-away (first stage the shock sensor), the siren will emit a short chirp.
 - b). Activate the full alarm (second stage the shock sensor), the siren will emit a long chirp.
 7. When you are satisfied with the setting, press  button to lock in the adjustment. One long siren chirp will indicate the unit has locked in the adjustment.
- Note: If 20 seconds of inactivity expires, or you turn on the ignition during of above steps, the unit will exit the program mode and return to the disarmed mode. Three long chirps to confirm exit.

This device complies with part 15 of the FCC rules. Operation is subject to the following two conditions.

- 1) This device may not cause harmful interference, and
- 2) This device must accept any interference received, including interference that may cause undesired operation.

Per FCC 15.21, you are cautioned that changes or modifications not expressly approved by the part responsible for compliance could void the user's authority to operate the equipment.



RF-215











PROFESSIONAL VEHICLE SECURITY SYSTEM

OPERATION MANUAL

THIS PRODUCT IS DESIGNED FOR PROFESIONAL INSTALLATION ONLY

TRANSMITTER OPERATION



Transmitter Button	System Function	Remark
 Button	Arm / Lock door	
 -  Button	Arm and Delete Optional Sensor	Press twice.

 Button	Car Locator	System in Armed.
 Button for 3 seconds	Panic function	Press 3 seconds
 Button	Disarm & Unlock Door	
 -  Button	Two Steps Door Unlock & Disarm System	Press twice within 3 seconds.
 Button	Car Locator	
 Button for 2 seconds	Pop Trunk Release	Press 2 seconds
 +  Button	Silent Arm / Disarm	Ignition in "off" position.
 +  Button for 1 seconds	Activate Car-Jacking	Ignition in "on" position.
	Switching code For 2nd Car Operation.	

ACTIVE ARMING – LOCK & ARM:

1. Press  button on transmitter.
2. The siren will chirp once and the parking lights will flash once indicating that the system is now armed. The vehicle doors will lock upon arming when interfaced with the security system.

Note: **Defective sensor reminder:** If the siren sounds 3 chirps, then you have left a door, trunk, or hood lid ajar.

SILENT ARMING / DISARMING: Press the  +  button together on the transmitter to arm or disarm your security system, No chirp sound will be heard; arm / disarm confirmation will be through the vehicles parking lights only.

SHOCK SENSOR / OPTIONAL SENSOR BY-PASS: Press the  button on the transmitter twice within 3 seconds will arm the security system, by-pass the shock sensor or the optional sensor connected to 4 pin plug. The system will chirp one additional time to confirm the sensor bypass mode was activated. The sensor bypass feature is programmed to activate for one arming cycle only. The security system will return to normal operation during the next arming cycle

PASSIVE ARMING:

Active arming / disarming is controlling your security system via the remote transmitter. This security system is equipped with an optional Passive Arming feature, which allows the security system to arm 30 seconds after the last door is closed. Operation is as follows.

1. Turn the ignition to the "OFF" position and exit the vehicle.
2. After all entrances are closed, the security system LED will flash fast for 30 seconds. If you reopen any door / hood / trunk, the security system LED will stop flashing. It will begin flashing again once all vehicle entrances are closed.
3. After 30-second timer has elapsed, the security system will automatically "ARM". The siren will chirp [1] time and the parking lights will flash [1] time.

PASSIVE DOOR LOCKING:

The vehicle doors will automatically lock after passive arming cycle has been completed.

ACTIVE DISARMING – UNLOCK & DISARM:

1. Press the  button on the transmitter.
2. The siren will chirp twice and parking lights will flash twice to indicate that the security system is now disarmed. The vehicle doors will unlock and disarm when interfaced with the security system.

TAMPER DISARMING: If the alarm is triggered; upon disarming the system, the siren will chirp 4 times and parking lights will flash 3 times.

TWO STEP DOOR UNLOCK: This feature will independently unlock the driver's door only when disarming the security system. Pushing the  button on the transmitter a second time within 3 seconds will unlock the entire vehicle.

AUTOMATIC RE-ARM: If this feature is selected, the security system will automatically re-arm itself 60 seconds after disarming with remote transmitter. Automatic rearm will cancel if any door is opened before the 60 seconds timer has elapsed.

DISARMING WITHOUT A TRANSMITTER

The Override function may be used if the remote transmitter is lost or inoperative.

1. Enter the vehicle and turn the ignition switch to 'ON' position. (Alarm will sound.)
2. Within 10 seconds push and release the valet switch

The alarm will stop sounding and enter the disarm mode. You can now start and operate the vehicle normally.

VALET MODE:

The valet switch allows you to temporarily bypass all alarm function, eliminating the need to hand your transmitter to parking attendants or garage mechanics. When the system is in valet mode, all alarm functions are bypassed, however, the remote panic feature and remote door locks will remain operational.

Enter Valet Mode:



1. Turn the ignition to "ON" position.
2. Push and hold valet switch for 2 seconds or until the LED turns on. The LED will remain on as long as the system is in 'valet mode'.

Exit Valet Mode:

1. Return to normal operation, turn ignition 'ON'.
2. Push and hold valet switch for 2 seconds; the LED will turn off indicating the system is exiting the valet mode.

PANIC FUNCTION:

The transmitter can be used as a remote panic switch to manually trigger the alarm in case of emergency.

1. Press and hold the  button on the transmitter for 3 seconds. The alarm will immediately sound.
2. To stop the alarm, press and hold the  or  button for 3 seconds on the transmitter, the panic mode will be turned off immediately.
3. If the button is not pressed, the alarm will automatically stop after 30 seconds.

Note: If the H3/6 Gray Wire is not a Trunk release Output, (See Alarm Feature III-2 Programming), Press and hold the  button on the transmitter for 3 seconds. The alarm will immediately sound.

TRIGGER THE SYSTEM

When armed, your vehicle is protected as follows:

1. Light impacts will trigger the warn-away signal. A long chirp from siren/horn.
2. Heavy impacts / Doors open / Hood open / Trunk open / Turning on the ignition switch- All will trigger the programmed sequence.



The starter disable relay (if installed) prevents the vehicle's starter from cranking. The siren and parking lights will turn on to alert of an intrusion for 30 seconds. Then the

siren will stop and automatically reset and re-arm. If any the sensors or detectors are still active, the alarm system will sound a maximum of six-30 second cycles.

ANTI CAR-JACKING

Warning: If you don't need the car jacking function in this alarm system, be sure to set car jacking feature "OFF". This system is default setting Car-jacking "OFF". (See Alarm Feature III - 3 Programming.)

1. TRANSMITTER ACTIVATE THE CAR JACKING:

Press and hold  +  button on the transmitter for 1 second while the vehicle's ignition is ON. The parking light will turn on for 1.5" seconds to indicate car jacking activated.

2. DOOR SWITCH ACTIVATE CAR JACKING:

1. Turn the ignition switch to "ON" position, the system is armed.
2. Once the system is armed, if you are forced from the vehicle, the system will activate the car jacking trigger when the door is opened and closed while the ignition is "ON".

TRIGGER THE CAR JACK MODE:

3-timer circuits will function as follows:

First timer:

- a. 50 seconds after the system has been triggered. The siren will start chirping for 15 seconds.
- b. During this 15 seconds period of chirping, you will be alerted to push the valet switch once to turn off the car-jacking feature.
- c. If not, it will enter second timer car jacking.

Second timer:

65 seconds after the system has been triggered. The siren starts alarming and the parking light starts flashing.

Third timer:

90 seconds after the system has been triggered

- a. The siren still alarming and the parking light flashing, and
- b. The starter disable will activate to prevent the vehicle from starting.
- c. It will remain active until the vehicle's battery power exhausted.

OVERRIDE THE SYSTEM TO TURN OFF CAR JACKING:

Turn the ignition switch from OFF to ON, and within 10 seconds push valet switch, the siren will stop and the system disarmed

IGNITION CONTROL DOOR LOCKS.

If the vehicle's door locks have been interfaced to the security system, the system will automatically lock the vehicle's doors when the ignition is turned "ON" and /or unlock the vehicle's doors when the ignition is turned "OFF".

TRUNK RELEASE.





Press and hold  button on transmitter for two seconds to remote control the trunk release or other electric devices.

CAR LOCATOR

Press the  button on the transmitter to activate car locator function. The siren will chirp 6 times. The parking light will flash 12 times, allowing you to easily locate your car.

ADJUST AND TEST THE SENSITIVITY LEVEL OF THE SHOCK SENSOR

1. Turn the Ignition 'switch ' ON/OFF' 3 TIMES and stay in OFF position.

2. Push the Valet switch 8 times and holding in on the 8th push until four chirps with a long chirp is heard then release the valet switch. You are now in the Alarm feature 'Shock Sensor' programming mode.
3. Press and hold  button for 2 seconds. One long siren chirp to indicates the unit is ready to accept adjustments of the shock sensor.
4. Press  button on the transmitter once. This will **decrease** sensitivity level by one, each time the button is pushed, a decrease is made the siren/horn chirp will respond with [1] chirp, while 2 chirp indicates the minimum of sensitivity.
5. Press  button on the transmitter once. This will increase sensitivity level by one, each time an increase is made the siren/horn chirp will respond with [1] chirp, while 2 chirp indicates the maximum sensitivity.
6. Hit the bumper or strong metal part of the vehicle to test the threshold level of the sensor.
 - a). Activate the warn-away (first stage the shock sensor), the siren will emit a short chirp.
 - b). Activate the full alarm (second stage the shock sensor), the siren will emit a long chirp.
7. When you are satisfied with the setting, press  button to lock in the adjustment. One long siren chirp will indicate the unit has locked in the adjustment.

Note: If 20 seconds of inactivity expires, or you turn on the ignition during of above steps, the unit will exit the program mode and return to the disarmed mode. Three long chirps will confirm exit.

ALARM OPERATING CONDITION:

Function	Siren	Parking Lights	LED	Doors	Starter Disable	Pager Option
1. Arm	1 Chirp	1 Flash	Slow flash	Locking	On	
2. Disarm	2or4 Chirps	2 or 3 Flashes	Off or Fast flash	Unlocking	Off	
3. Trigger	Alarming	Flashing	Slow flash		On	On
4. Panic	Alarming	Flashing	Slow flash	Locking	On	

ALARM INDICATORS

CHIRP INDICATORS:

Chirp	Function
1 chirp	Arm
2 chirps	Disarm
3 chirps	Defective reminder
4 chirps	Disarm/ Intrusion

PARKING LIGHTS:

Parking Light	Function
1 flash	Arm
2 flashes	Disarm
3 flashes	Disarm/ Intrusion

LED INDICATORS:

LED	Function
Off	Disarmed
Slow flash	Armed

LED	Function
2 flashes... pause	Trigger on trunk/hood
3 flashes...	Trigger on door

Fast flash	Passive arming
On (solid)	Valet mode

pause	switch
4 flashes... pause	Trigger on Dual Zone Shock Sensor
5 flashes... pause	Trigger on Ignition switch

This device complies with part 15 of the FCC rules.
Operation is subject to the following two conditions.

- (1) This device may not cause harmful interference, and
- (2) This device must accept any interference received, including interference that may cause undesired operation.

Per FCC 15.21, you are cautioned that changes or modifications not expressly approved by the party responsible for compliance could void the user's authority to operate the equipment.