



Advanced Card Systems Limited
Card & Reader Technologies

ACR1255 NFC Bluetooth Smart Card Reader

User Manual V1.02





Table of Contents

1.0.	Introduction	3
1.1.	NFC and Smart Card Reader	3
1.2.	Compact Design	3
1.3.	Firmware Upgradeable Feature.....	3
1.4.	Bluetooth® Connectivity	3
1.5.	Ease of Integration.....	3
2.0.	Features	4
3.0.	Typical Applications.....	6
4.0.	Driver installation For Windows®	7
4.1.	Install ACS Unified Bluetooth driver	7
4.2.	Set up device pairing with built-in Bluetooth adapter	10
4.3.	Using the ACS Bluetooth Device Management Tool.....	12
4.3.1.	Install a device	12
5.0.	Technical Specifications.....	15

1.0. Introduction

ACR1255 NFC Bluetooth Smart Card Reader combines the latest 13.56 MHz contactless technology with Bluetooth Smart connectivity for on-the-go smart card and NFC applications.

1.1. NFC and Smart Card Reader

ACR1255 supports ISO 14443 Type A and B smart cards, MIFARE®, FeliCa®, and most NFC tags and devices compliant with ISO 18092 standard. This makes it the ideal device for a broad range of solutions, such as hands-free verification for physical and logical access control, and inventory tracking. ACR1255 has both Bluetooth interface for pairing with mobile devices and USB Full Speed for PC-linked operation. Additionally, it can read/write at speeds of up to 424 Kbps for contactless smart card and NFC device access.



1.2. Compact Design

With a compact design and a rechargeable Lithium-ion battery for power, ACR1255 is extremely portable and convenient for use anytime, anywhere with most Bluetooth-enabled smartphones and tablets in the market.

1.3. Firmware Upgradeable Feature

To save valuable cost and time, the firmware of ACR1255 could conveniently be upgraded in-field to allow users to cope with the fast-changing technology for their applications in order to suit different scenarios.

1.4. Bluetooth® Connectivity

With Bluetooth® Low Energy (LE) 4.0 technology, ACR1255 can connect wirelessly with ease to any device running on Android™ 4.3 and above, iOS 5.0 and above, Windows®, and Mac OS X® operating systems.

1.5. Ease of Integration

ACR1255 could easily be installed for use with any PC running on Windows® operating system because it is PC/SC and CCID compliant. Its drivers are also compatible with Linux® and Mac OS X®.

With its numerous features, the ACR1255 is the perfect Bluetooth NFC reader for your smart card solution.



2.0. Features

- USB 2.0 Full Speed Interface
- Bluetooth Low Energy (LE) 4.0 Interface
- Plug and Play – CCID support brings utmost mobility¹
- USB Firmware Upgradeability²
- Smart Card Reader:
 - Built-in antenna for contactless tag access, with reading distance of up to 60 mm (depending on tag type)
 - Supports ISO 14443 Part 4 Type A and B cards
 - Supports MIFARE® and MIFARE DESFire®
 - Supports FeliCa®
 - Supports ISO 18092 Tags (NFC Tags)
 - Built-in anti-collision feature (only one tag is accessed at any time)
 - NFC Support:
 - Card reader/writer mode
 - Card emulation mode
 - Supports AES-128 encryption algorithm
- Application Programming Interface:
 - Supports PC/SC³
 - Supports CT-API (through wrapper on top of PC/SC)
- Supports Android™ 4.3 and above⁴
- Supports iOS 5.0 and above
- Built-in Peripherals:
 - Two user-controllable bi-color LEDs
 - User-controllable buzzer
- Compliant with the following standards:
 - EN60950/IEC 60950
 - ISO 18092
 - ISO 14443
 - CE
 - FCC
 - VCCI
 - PC/SC
 - CCID

¹ *Applicable under PC-linked mode*

² *Same as above*

³ *Same as above*

⁴ *PC/SC and CCID support is not applicable.*



- Bluetooth® QDL
- Microsoft® WHQL
- RoHS2
- REACH



3.0. Typical Applications

- Mobile Banking & Payment
- e-Government
- e-Healthcare
- Network Security
- Access Control
- e-Purse & Loyalty
- Public Key Infrastructure



4.0. Driver installation For Windows®

4.1. Install ACS Unified Bluetooth driver

To install the driver:

1. Run the **ACS Unified Bluetooth Driver**.
2. The Setup Wizard will show. To start the installation, click **Next**.

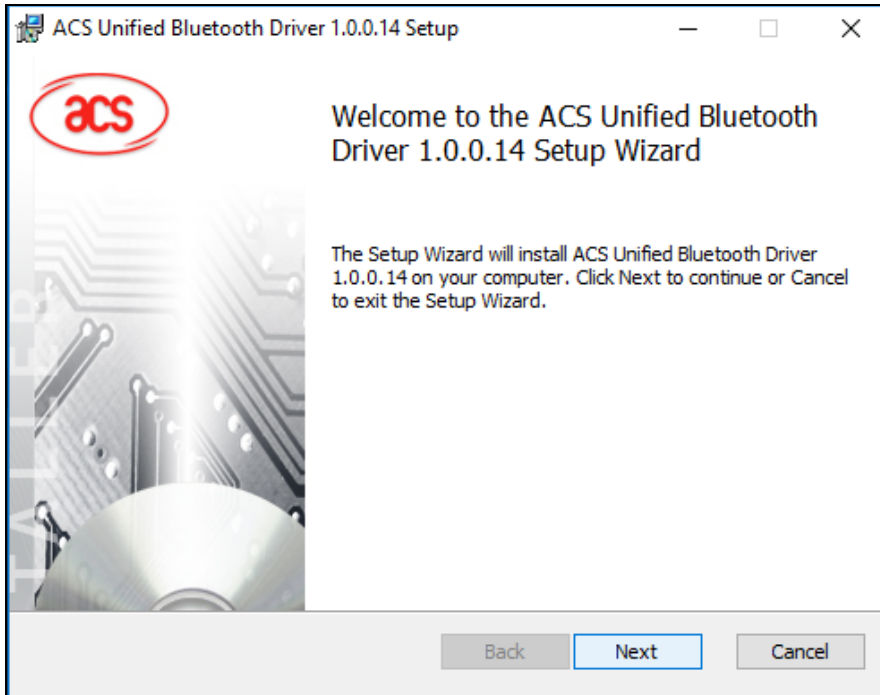

3. Click **Next** to install the driver to the default destination, located at **X:\Program Files\Advanced Card Systems Ltd\ACS Unified Bluetooth Driver 1.0.0.14**, with X as your local Windows drive.

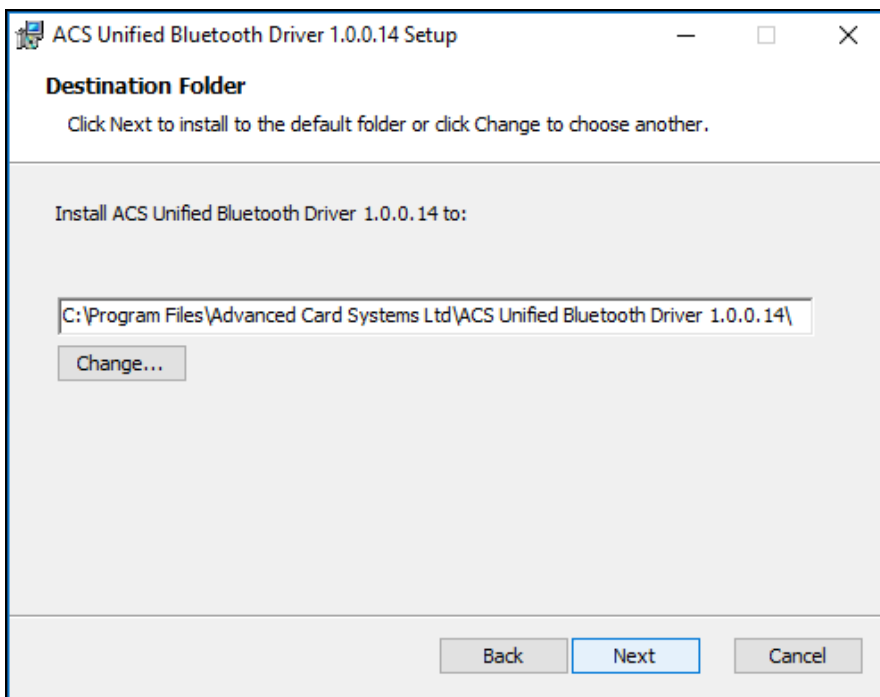



4. Click **Install**.

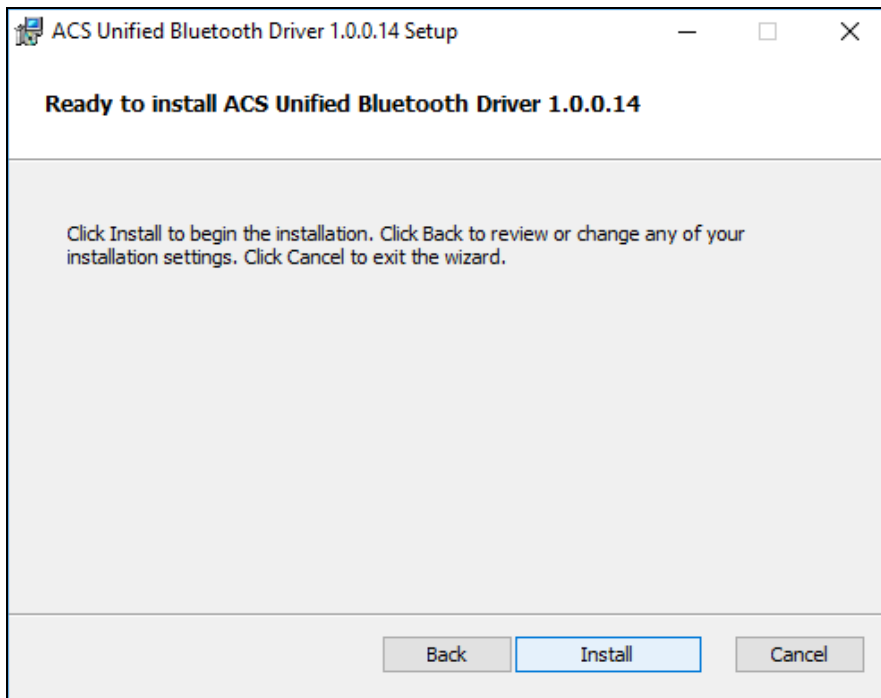

5. Wait while the driver installs.

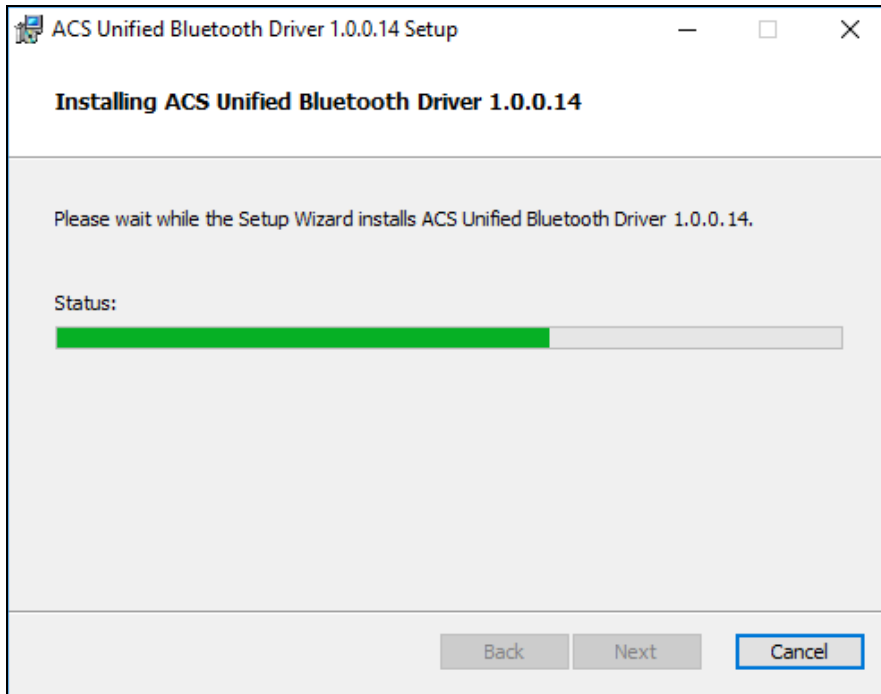



6. Once the installation is complete, click **Finish**.

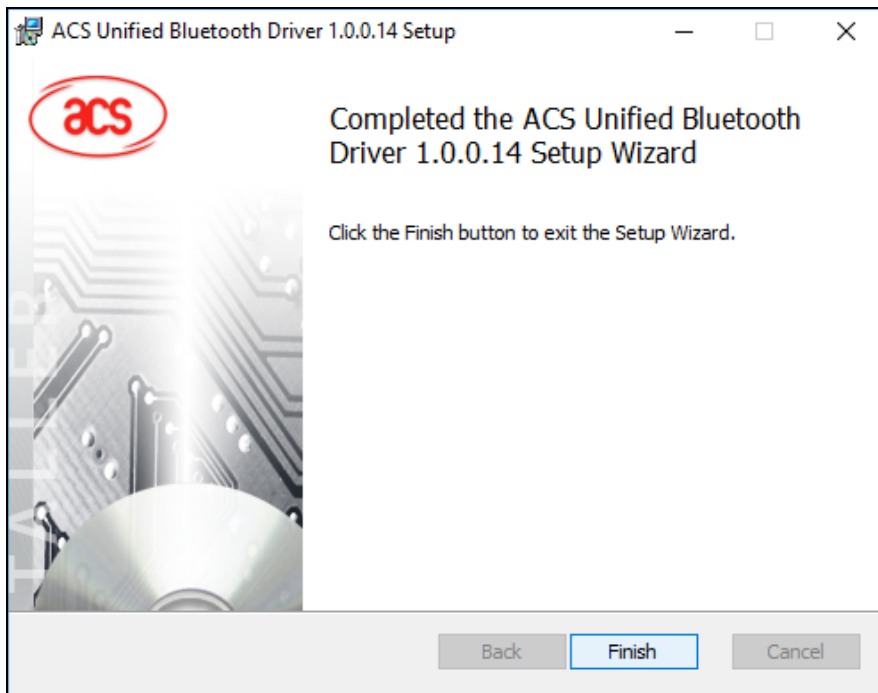

4.2. Set up device pairing with built-in Bluetooth adapter

Note: This procedure only applies to Windows 8 and later. Windows 7 does not support devices using Bluetooth 4.0/Bluetooth Low Energy interface.

To pair using this setup:

1. Turn on the Bluetooth mode of ACR1255 to make it discoverable. To do this, slide the toggle switch to the right.



2. Go to **PC Settings** , choose **PC and devices**, and then click **Bluetooth**.

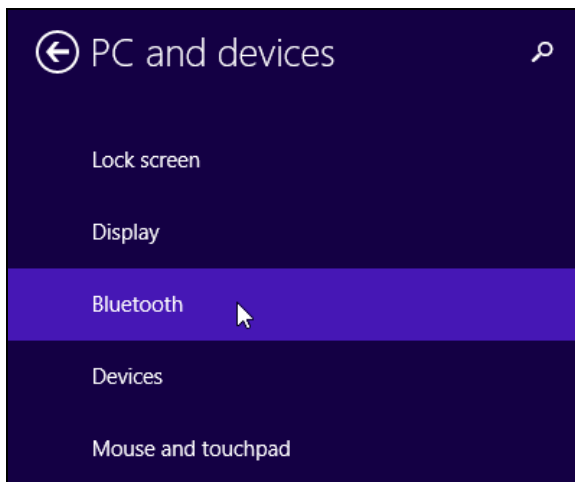

3. Turn on **Bluetooth**.

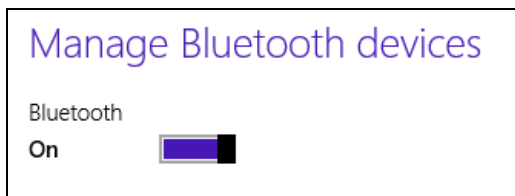



4. Select ACR1255, and then click **Pair**.

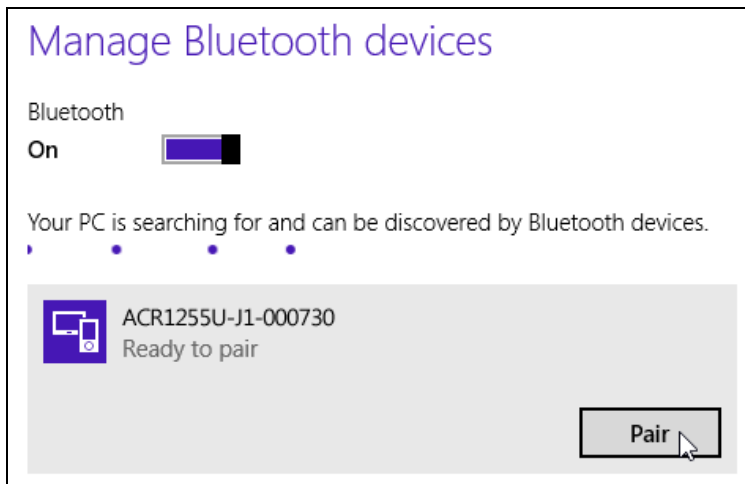

5. The pairing is complete when you see ACR1255 is connected.

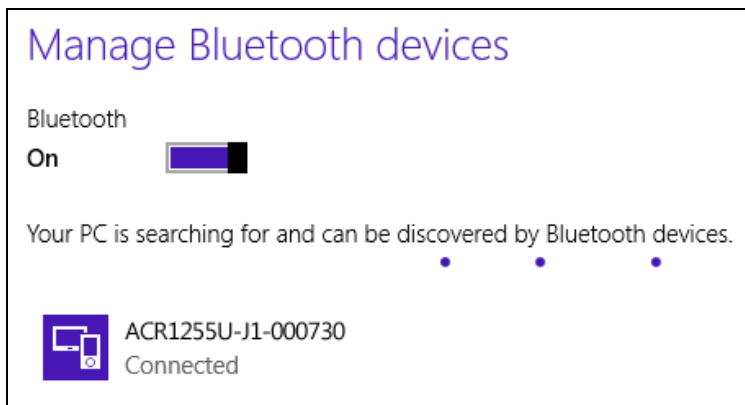

6. To complete the installation of the Bluetooth card reader, go to [Using the ACS Bluetooth Device Management Tool](#).



4.3. Using the ACS Bluetooth Device Management Tool

ACS Bluetooth Device Management Tool is an application that enables you to easily manage device pairings between ACS Bluetooth card readers and computers.

4.3.1. Install a device

To establish full connection, you must install the Bluetooth card reader in the ACS Bluetooth Device Management Tool.

Note: *The TI USB dongle can only work on a one-to-one connection with an installed ACS Bluetooth card reader. If there is a previously installed Bluetooth card reader in the tool, uninstall it first (see [Error! Reference source not found.](#)).*

To begin:

1. Turn on the Bluetooth mode of ACR1255 and make it discoverable. To do this, slide the toggle switch to the right.



2. Run the **ACS Bluetooth Device Management Tool**.
3. Wait while the tool scans for Bluetooth devices within range.

Note: *If the device is not immediately discovered, click **Refresh**.*

4. Once the tool discovers ACR1255, it will show in the list.

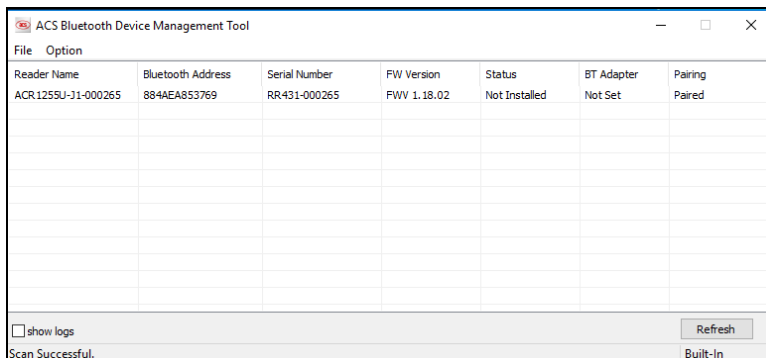

- In the **Option** menu, click **Install**.

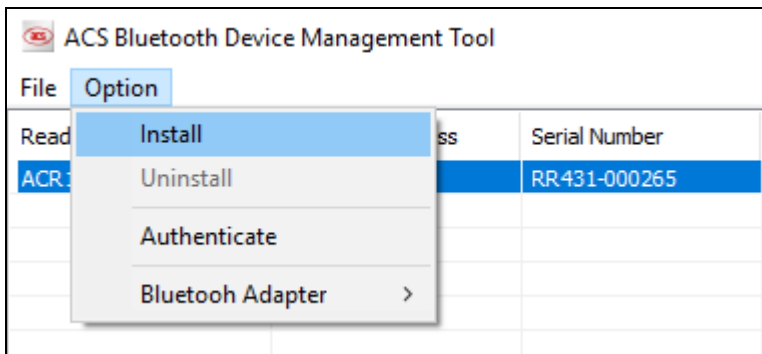

An alternative way to do this is to right-click on the device, and then click **Install**.

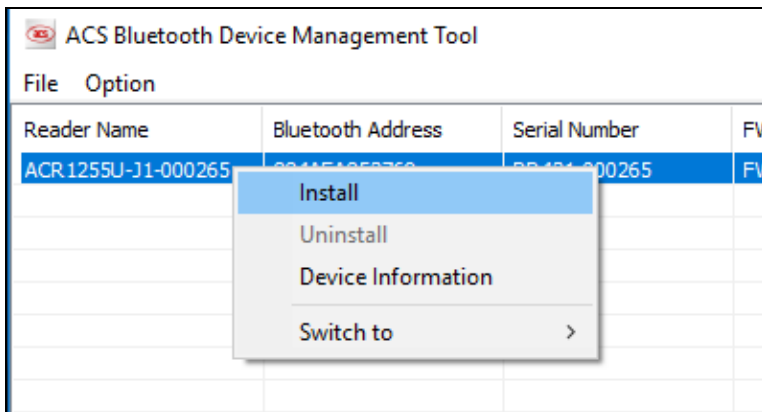

- Type in a 16-byte hexadecimal key for authentication, or use the default value. Click **Install**.

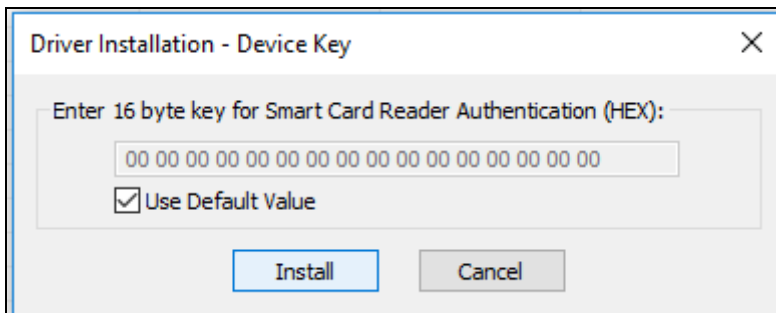

Note: The default authentication key is 00 00 00 00 00 00 00 00 00 00 00 00 00 00 00 00.

- Wait while the application installs the driver.
- A message will appear confirming a successful installation. Click **OK**, and then reset your device.

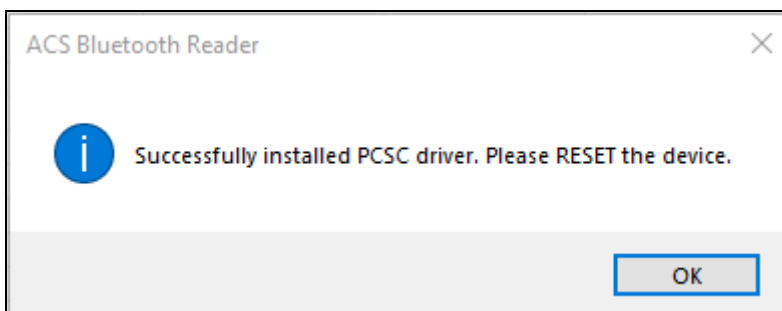



9. After a successful driver installation, you can now use ACR1255 with various smart card applications. Below is a sample of ACR1255 connected in **QuickView**.

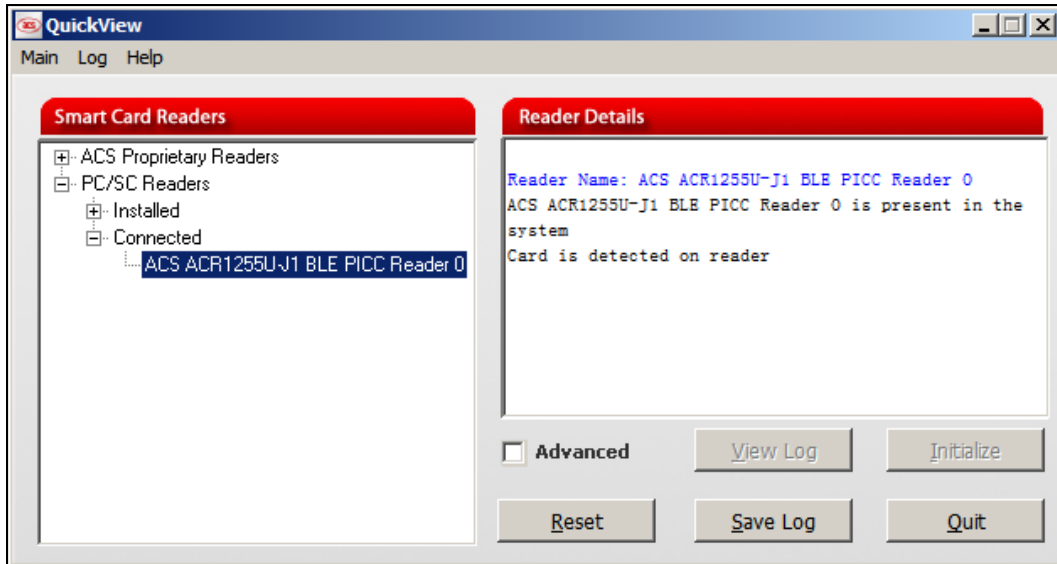

5.0. Technical Specifications

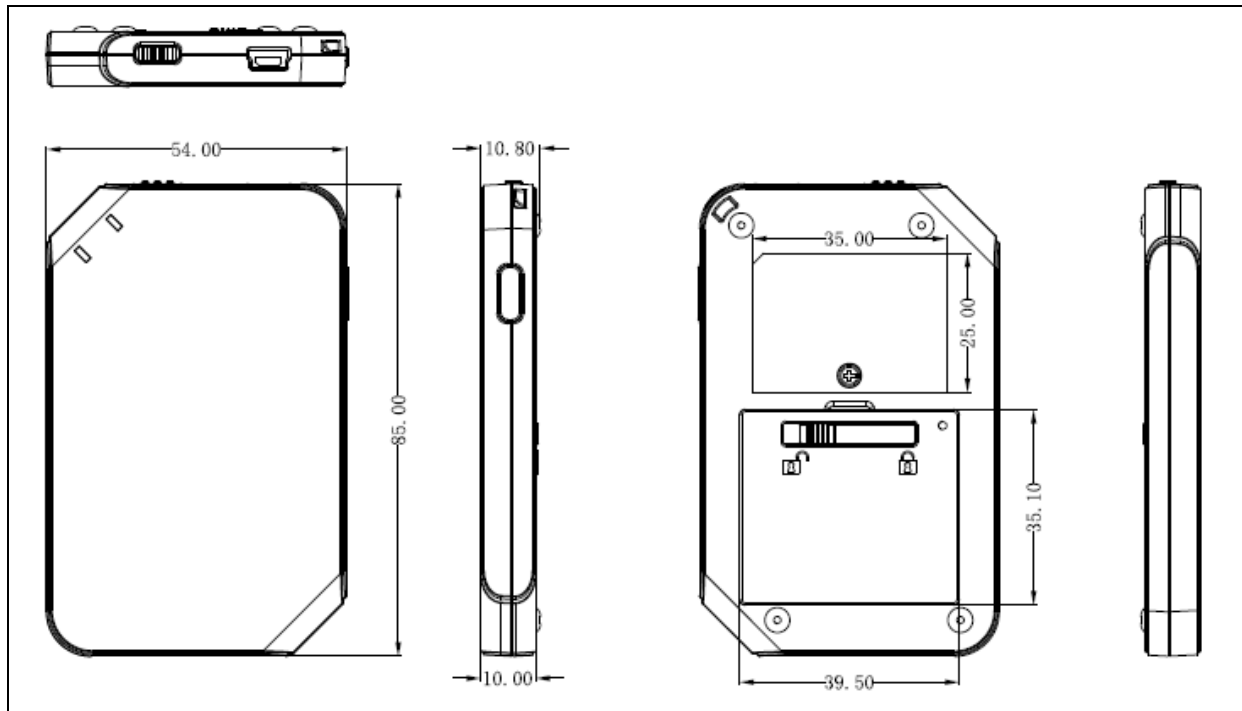

Universal Serial Bus Interface

Type	USB Full Speed, four lines: +5 V, GND, D+ and D-
Power Source.....	From USB
Speed.....	12 Mbps
Supply Voltage.....	Regulated 5V DC
Supply Current.....	<250mA
Battery Specification.....	Lithium-ion Battery (320mAh)
Firmware	Upgradeable through USB interface

Bluetooth Interface

Type	Bluetooth Smart 4.0
Power Source.....	From battery
Operating Frequency	2.4 GHz
Speed.....	1 Mbps (on-air data rate)

Contactless Smart Card Interface

Standard	ISO/IEC 18092 NFC, ISO 14443 Type A & B, MIFARE, DESFire, FeliCa
Protocol.....	ISO 14443 T=CL for ISO14443-4 compliant cards and T=CL Emulation for MIFARE Classic 1K/4K, ISO 18092, FeliCa and NFC tags
Operating Frequency	13.56 MHz
Operating Distance	Up to 60 mm (depending on tag type)
Smart Card Read/Write Speed.....	106 Kbps, 212 Kbps, 424 Kbps

Physical Specifications

Dimensions	85.0 mm (L) x 54.0 mm (W) x 10.8 mm (H)
Color	White
Weight.....	37.5 g (63.0 g with cable ± 5 g allowance for cable)
Cable length, cord, connector,color.	1 m, Fixed (detachable), USB A, white
Antenna size	45.6 mm x 42.0 mm

Built-In Peripheral

LED	2, Bi-color (Red and Blue, Red and Green.)
Buzzer	Monotone

Operating Conditions

Temperature.....	0 °C – 50 °C
Humidity	Max. 90% (non-condensing)
MTBF	500,000 hrs

Application Programming Interface

PC/SC	
CT-API (through wrapper on top of PC/SC)	



Certifications/Compliance

EN60950/IEC 60950, ISO 18092, ISO 14443, NFC Forum, CE, FCC, VCCI, PC/SC, CCID, RoHS 2, REACH, USB Full Speed, Bluetooth® Smart, Microsoft® WHQL Windows® 2000, Windows® XP, Windows Vista®, Windows® 7, Windows® 8, Windows® 8.1, Windows® Server 2003, Windows® Server 2008, Windows® Server 2008 R2, Windows® Server 2012, Windows® Server 2012 R2

Device Driver Operating System Support

Windows® 98, Windows® ME, Windows® 2000, Windows® XP, Windows Vista®, Windows® 7, Windows® 8, Windows® 8.1, Windows® Server 2003, Windows® Server 2003 R2, Windows® Server 2008, Windows® Server 2008 R2, Windows® Server 2012, Windows® Server 2012 R2
Linux®, Mac OS®, Android™¹, iOS²



Android is a trademark of Google Inc.
Atmel is registered trademark of Atmel Corporation or its subsidiaries, in the US and/or other countries.
Infineon is a registered trademark of Infineon Technologies AG.
Linux® is the registered trademark of Linus Torvalds in the U.S. and other countries.
Mac OS is a trademark of Apple Inc.
Microsoft, Windows and Windows Vista are either registered trademarks or trademarks of the Microsoft Corporation in the United States and/or other countries.

¹ 4.3 or above Android version is required for Bluetooth 4.0.

² 5.0 and above iOS version is required.



FCC Warning:

This device complies with part 15 of the FCC Rules. Operation is subject to the following two conditions:

(1) This device may not cause harmful interference, and (2) this device must accept any interference received, including interference that may cause undesired operation. Any Changes or modifications not expressly approved by the party responsible for compliance could void the user's authority to operate the equipment.

Note: This equipment has been tested and found to comply with the limits for a Class B digital device, pursuant to part 15 of the FCC Rules. These limits are designed to provide reasonable protection against harmful interference in a residential installation. This equipment generates, uses and can radiate radio frequency energy and, if not installed and used in accordance with the instructions, may cause harmful interference to radio communications. However, there is no guarantee that interference will not occur in a particular installation. If this equipment does cause harmful interference to radio or television reception, which can be determined by turning the equipment off and on, the user is encouraged to try to correct the interference by one or more of the following measures:

- Reorient or relocate the receiving antenna.
- Increase the separation between the equipment and receiver.
- Connect the equipment into an outlet on a circuit different from that to which the receiver is connected.
- Consult the dealer or an experienced radio/TV technician for help