

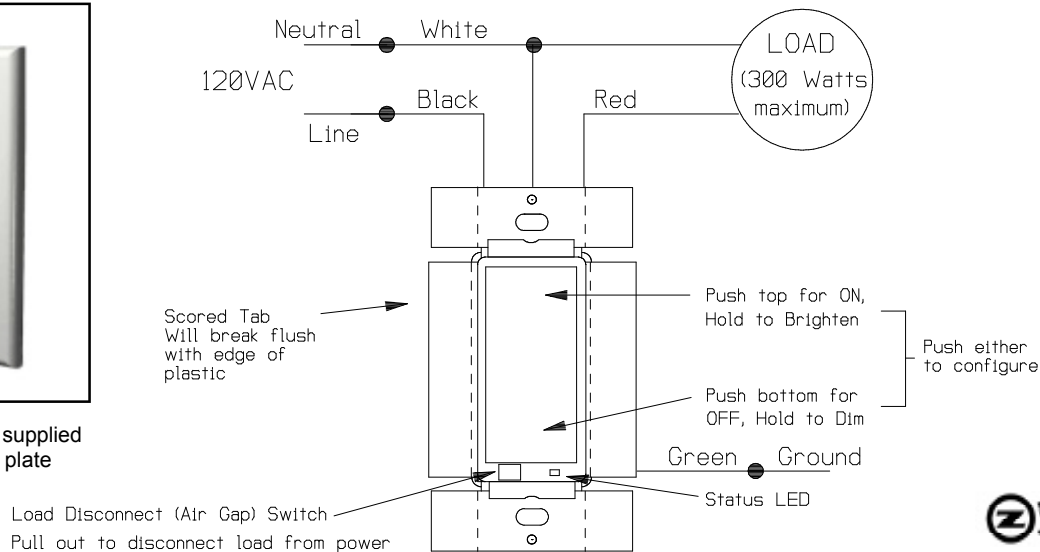

Shown with user supplied
Decora™ trim plate



ZDW100 WALL MOUNTED DIMMER

The ZDW100 Wall Mounted Dimmer is a component of the HomePro lighting control system. Wire the Wall Mounted Dimmer in place of the standard wall switch according to the diagram above and program from the Wireless Controller to operate loads. Inclusion of the Wall Mounted Dimmer on the ZTH100 Wireless Controller menu allows remote ON/OFF control and dimming of light connected.

This Wall Mounted Dimmer is designed to work with other HomePro lamp and appliance controls. Z-Wave nodes of other types can be added to the system and will also act as repeaters if they support this function of repeating the signal received to other modules in the system.

As part of a HomePro network, the ZDW100 will also act as a wireless repeater to insure that commands intended for another device in the network are received. This is useful when the device would otherwise be out of the radio range of the wireless controller.

There are no field repairable assemblies on this unit. It is covered by a one year limited warranty. If service is needed, the unit must be returned where purchased.

CAUTION! Read and understand these instructions before installing. This device is intended for installation in accordance with the National Electric code and local regulations in the United States, or the Canadian Electrical Code and local regulations in Canada. It is recommended that a qualified electrician perform this installation.

To reduce the risk of overheating and possible damage to other equipment, do not install to control a receptacle, a motor operated appliance, a fluorescent lighting fixture, or a transformer-supplied appliance, but *only permanently installed incandescent lamp fixtures*. Make sure the lamp(s) to be controlled directly from the dimmer switch total no more than 300 watts. Retain instructions for future use.

INSTALLATION

CAUTION! - SHOCK HAZARD. Make all connections with the **POWER OFF** to avoid injury to the installer or damage to the device.

1. Strip 3/4" of insulation from the ends of the conductors (if not already done) and make connections as shown in the Wiring Diagram.
2. Check connections to be sure they are tight and no bare conductors are exposed.
3. Make sure the load or installation does not exceed the device rating.
4. Install into an appropriately sized electrical switch box. Scored tabs on both sides can be bent up and down their length with pliers to break off, to allow fitting in a variety of electrical box types.
5. Restore the power..

Wire this Wall Mounted Dimmer in place of a current wall switch according to the diagram. Refer to the Wireless Controller operating instructions to add this module under the command of the Wireless Controller.

Wall Mounted Dimmer Configuration

The Wall Mounted Dimmer switch locally controls the load ON and OFF. Adjust its dimming level by pressing and holding the top of the switch for Brighten, press and hold the bottom of the switch for Dim. Push on the top or the bottom of the switch to configure the module to operate from the wireless controller. With the Wireless Controller, the Wall Mounted Dimmer can be switched ON and OFF remotely, dimmed remotely and can be included in groups of lights that operate at the same time (a group can also be a single module), and in scenes that set a lighting mood.

Switch power ON and OFF locally

When the switch is pressed on the top the power will turn ON if off. Press the bottom of the switch and the power will turn OFF if it was on.

Dimming

If the bottom of the switch is pressed and held the light will dim. When the top is pressed and held, the light will brighten.

Child Protection

The Wall Mounted Dimmer can be set in a child protect mode by the Wireless Controller. When this mode is active, a user will have to press the Wall Mounted Dimmer 3 times rapidly to activate the attached load. The module operates normally when controlled by the Wireless Controller..

Other functions

The switch on the Wall Mounted Dimmer also plays a role as a reset in addition to adding module to groups and scenes. This is described in more detail in the Wireless Controller instructions.

Air Gap Switch

The ZDW100 has an air gap switch on the face (lower left), that when pulled out, completely removes the power available to the load (more so than simply turning the dimmer off). This enables the lamps that are controlled by the device to be changed with minimal danger of electrical shock. The air gap switch must be pushed all the way back in for the dimmer to operate the lamps again.

Software fuse

This Wall Mounted Dimmer is designed to protect itself against loads that exceed it's maximum power rating. The application of a load that exceeds that rating is quickly sensed by the dimmer and it responds by immediately shutting off all power to that load.

If the dimmer doesn't seem to work, or only works momentarily, check to see that the total lamp wattage doesn't exceed the 300W rating of the dimmer. If a properly sized load is restored to the dimmer, it can be operated normally once again.

Over-current protection

The Wall Mounted Dimmer hardware also has an over current detection circuit as final protection against overload. If the software fuse should fail to shut down the dimmer when overloaded, backup protection is provided by an internal fuse. This internal fuse is not user serviceable. Check your home circuit breakers before concluding that the product must be returned to manufacturer for repair at a nominal charge.

Operation Note

When a light bulb reaches the end of it's life and burns out, it sometimes creates a momentary short circuit. The high current that results may cause the dimmer to properly respond by turning off. Should this happen, replace the bulb with a new one. The dimmer can then be operated to restore power to the light.

WARRANTY

Advanced Control Technologies, Inc. gives this expressed warranty (along with extended warranty endorsements, where applicable) in lieu of all other warranties, express or implied, including (without limitation), warranties of merchantability and fitness for a particular purpose. This constitutes Advanced Control Technologies, Inc.'s sole warranty and obligation with regard to our products as well as the Customer's sole remedy.

Advanced Control Technologies, Inc. expressly disclaims all liability and responsibility for any special, indirect or consequential damages or any further loss of any kind whatsoever resulting from the use of our product. The Customer's sole and exclusive remedy and the limit of Advanced Control Technologies, Inc.'s liability for any loss whatsoever, shall not exceed the purchase price paid by the Customer for the product to which a claim is made.

Some states do not allow limitations of incidental or consequential damages or on how long an implied warranty lasts, so the above limitations may not apply to you. This warranty gives you specific legal rights, and you may also have other rights which vary from state to state. All products manufactured by Advanced Control Technologies, Inc. are warranted to be free from defects in material and workmanship in accordance with and subject to the following terms and conditions:

1. This warranty is limited to the original Customer only. It cannot be transferred or assigned to third parties unless the intent to transfer to a third party is expressly indicated in a purchase order and/or warranty processing arrangements have been agreed upon in writing by Advanced Control Technologies, Inc.
2. Advanced Control Technologies, Inc. will correct any defects in material or workmanship which appear within one (1) year from the date of purchase. Advanced Control Technologies, Inc. will repair or replace, at our option, any defective products, provided that our inspection discloses that such defects developed under normal and proper use. This warranty does not extend to goods subjected to misuse, neglect, accident or improper installation, or to maintenance or repair of products which have been altered or repaired by anyone except Advanced Control Technologies, Inc. unless otherwise stated in writing.
3. An appropriate charge (50% of product list price) will be made for testing, repairs, replacement and shipping for returned product which is not defective or found to be defective as the result of improper use, maintenance or neglect.
4. Information in our descriptive literature is based on product specifications that are current at the time of publication. Product specifications, designs and descriptive literature are subject to change as improvements are introduced. Although we announce changes as they occur, we cannot guarantee notification to every Customer. Advanced Control Technologies, Inc. warrants delivered product to conform to the most current specifications, designs and descriptive literature.

This device complies with part 15 of the FCC Rules. Operation is subject to the following two conditions: (1) This device may not cause harmful interference, and (2) This device must accept any interference received, including interference that may cause undesired operation.

FCC NOTICE

Note: This equipment has been tested and found to comply with the limits for a Class B digital device, pursuant to part 15 of the FCC Rules. These limits are designed to provide reasonable protection against harmful interference in a residential installation. This equipment generates, uses, and can radiate radio frequency energy and, if not installed and used in accordance with the instructions may cause harmful interference to radio communications. However, there is no guarantee that interference will not occur in a particular installation. If this equipment does cause harmful interference to radio or television reception, which can be determined by turning the equipment off and on, the user is encouraged to try to correct the interference by one or more of the following measures:

- Increase the separation between the equipment and receiver.
- Consult the dealer or an experienced radio/TV technician for help.

IC NOTICE

This Class B digital apparatus complies with Canadian ICES-003.

Cet appareil numérique de la classe B est conforme à la norme NMB-003 du Canada.

Operation is subject to the following two conditions: (1) this device may not cause interference, and (2) this device must accept any interference, including interference that may cause undesired operation of the device.

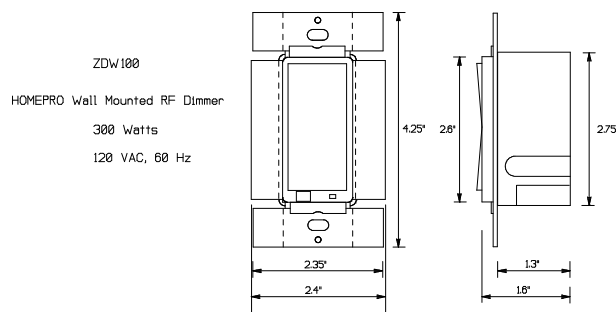

Power	120 VAC, 60 Hz
Signal (Frequency)	908.42 MHz
Maximum Load	300 W, for incandescent lamps only
Range	Up to 100 feet line of sight between the Wireless Controller and /or the closest HomePro Receiver Module