

## 6 Series

## Quick Reference Guide

v 1.0

PQR-6700-1.0-E

## Advanced Mobile Payment Inc.

Units 401-403, 15 Wertheim Court. Richmond Hill,  
Ontario L4B 3H7 CANADA

Note: This information is CONFIDENTIAL and must be used exclusively for the operation of Advanced Mobile Payment Inc.'s (AMP) products. It may not be duplicated, published, or disclosed without prior written permission.

## PROPRIETARY NOTICE

All pages of this document contain information proprietary to Advanced Mobile Payment Inc (AMP). This document shall not be duplicated, transmitted, used, or otherwise disclosed to anyone other than the organization or specific individuals to which this document is delivered, and then only for the purpose of evaluation of the AMP proposal. This restriction is applicable to all sheets of this document. AMP reserves the right to have the recipient return all copies of this document at any time.

© 2017 AMP Inc. All Rights Reserved

## DOCUMENT PROPERTIES

## Information

<b>ID</b>	PQR-6700-1.0-E
<b>Title</b>	Quick Reference Guide
<b>Category</b>	AMP POS 6 Series - 6700
<b>Access Level</b>	General

## Version Control

Version	Date	Summary of Change	Updated by
1.0	Aug 2017	Initial version	R. Gibbs

## Supported Hardware &amp; Software

Version	Software Release	Supported Hardware Model
1.0+	1.0	AMP POS 6 Series - 6700

## CONTENTS

1	Introduction	4
2	6 Series - 6700 Architecture	4
2.1	Front View	4
2.2	Back & Side View	5
2.3	Ports	5
3	General Precautions	6
4	Powering Device On/Off	6
5	Installing SAM Card	7
6	Troubleshooting Common Problems	8
7	Technical Specifications	9

## The following items should be found inside the original packaging:

- 6 Series POS terminal
- The AC power supply and plug
- Product Quick Reference Guide

## 1 Introduction

Engage customers in new ways with the AMP 6 Series' crystal clear 7" color touch display and video capabilities, all while accepting payment options that appeal to them with signature capture, chip and PIN, NFC/contactless, smartphone payments, electronic wallets and tap-and-go compatibility. The Android OS and powerful ARM secure processor provide power and simple application development options to meet the most demanding needs of any multi-lane or self-checkout environment. Optimized for the next generation of value-added services, gift card issuing and support of loyalty schemes, the AMP 6 Series is the ultimate choice for a complete multimedia transaction solution.

## 2 6 Series - 6700 Architecture

## 2.1 Front View

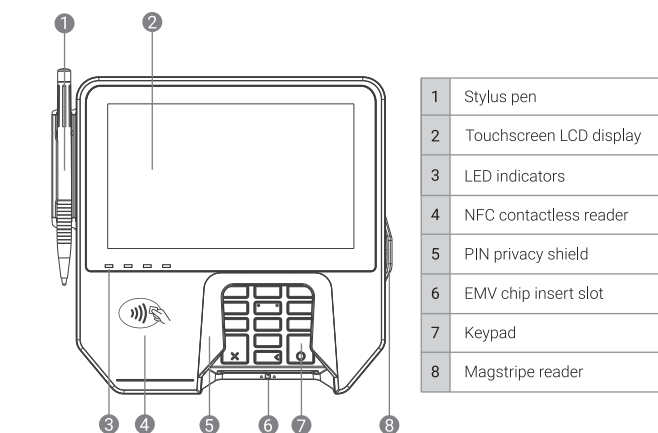

## 2.2 Back &amp; Side View

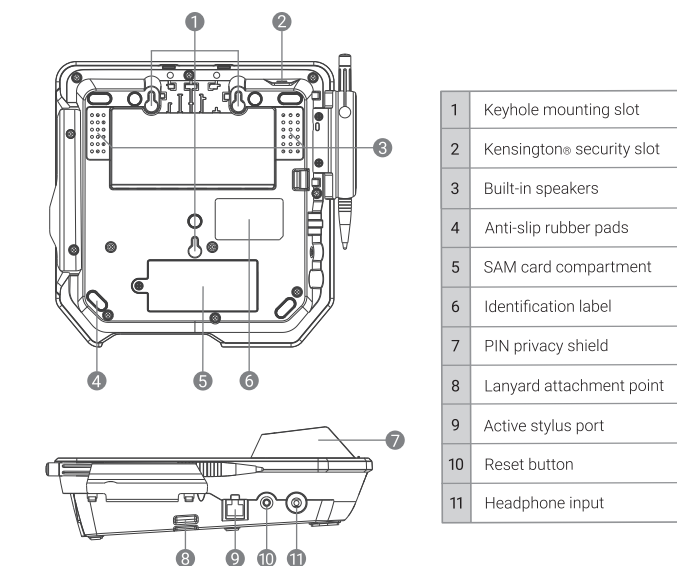

## 2.3 Ports

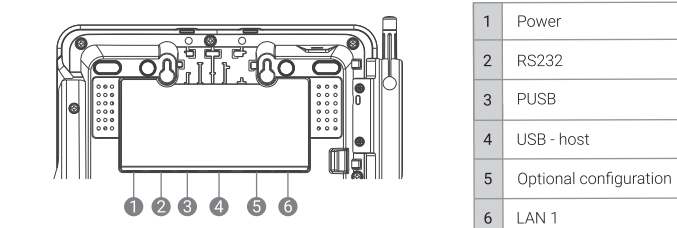

## 3 General Precautions

Basic care and consideration should be used when handling, operating or installing the 6 Series terminal. This is a secure device, with both physical and logical tamper protection, and no attempt should be made by the user to open or service the device in any way other than approved troubleshooting methods. Keep these basic guidelines in mind to prolong the longevity and functionality of your product:

- Use only the dedicated power supply provided with the terminal to avoid damage to the device's electrical components
- Avoid spills or exposure to liquids, which could cause the terminal to short circuit
- Protect the terminal from impact, including: vibration, shaking, knocks, falling objects, being dropped, etc.
- Keep the terminal from environments that produce excessive dust, humidity, high or low temperatures or electromagnetic fields
- While charging, do not attach or remove any components to avoid damage to the internal circuitry
- There are no user-serviceable internal parts or mechanisms, do not try to open, modify or repair the device
- Be aware, this terminal contains a failsafe where all internal data will be erased immediately upon detection of tampering (such as opening the housing)
- If a fault occurs, immediately disconnect the power supply, discontinue use and contact your service provider to request repairs and diagnostics

## 4 Powering Device On/Off

## Powering On the device

First ensure that the plug is inserted into a known working socket, then insert the DC jack into the power port on the 6 Series, the device will then power itself On.

## Powering Off the device

Unplug the DC jack from the back of the terminal and it will power itself Off.

## 5 Installing SAM Card

## Installation of a SAM card

- Open the rear cover to reveal the card slots
- With the exposed chip facing downward, and the angled corner oriented away from the slot, insert the card until it is seated right at the bottom of the slot
- Ensure that any installed cards are securely locked in place, and close the rear cover

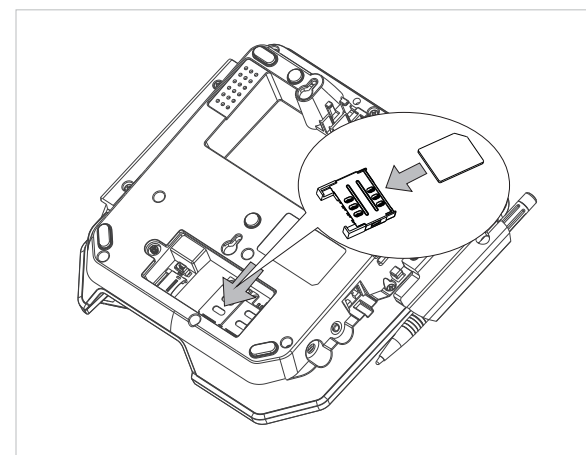

Install the SAM card

## 6 Troubleshooting Common Problems

If problems occur with the terminal, try these simple troubleshooting methods to correct the fault, or contact a service representative to further diagnose the issue.

Problem	Troubleshooting
Nothing displayed on screen	Ensure the power is properly connected at the socket and DC jack
Unable to read card	Ensure that the slot is free of debris or foreign objects Swipe the card in both directions, and check if error has been corrected Check if the current card is operational, and test with a different card
Magnetic reader data read error	Swipe the card with constant speed, tight to the bottom edge of the slot Ensure the card strip is facing the screen and aligned properly with the slot Try swiping the card in the opposite direction
Chip card data read error	Ensure the chip portion is facing upwards, and is properly inserted into the slot Check the card for excessive scratches, dirt, or other damage
Contactless card data read error	Confirm that the card supports contactless communication Check whether the card is properly aligned above the contactless reader area
Communication error	Restart the terminal in order to re-establish communications Confirm that the SAM card is properly installed, and that its contacts are clean If using WiFi, check that the terminal's connection is enabled

If problems persist after completing these troubleshooting procedures, please contact your sales or service representative. **Do not** attempt to open the terminal or make further repairs. **CAUTION RISK OF EXPLOSION IF BATTERY IS REPLACED BY AN INCORRECT TYPE. DISPOSE OF USED BATTERIES ACCORDING TO THE INSTRUCTIONS**

## 7 Technical Specifications

The following are specifications detailing the overall capabilities of the AMP 6 Series, including optional or variable elements. To obtain the specifications for your individual terminals, refer to the original sales order or your sales representative for more information.

<b>PROCESSOR</b>	32-bit secure processor, Cortex A9, BCM58303, 1.25 GHz
<b>MEMORY</b>	8 GB flash, 1GB DDRL3
<b>DISPLAY</b>	7" 600x1024 IPS LCD capacitive touch screen, fully video capable, signature capture
<b>CONNECTIVITY</b>	WiFi, Bluetooth 4.0, RS232, USB host, USB OTG, LAN1, LAN2
<b>CERTIFICATION</b>	EMV 4.3 level I and II, PCI PTS 4-X, EMV contactless level I
<b>CARD READERS</b>	Bi-directional triple-track magstripe reader, landed smart card, NFC
<b>OTHER</b>	2 SAM slots, audio and video capability, SD card reader, POE, stylus, mic 8 line out
<b>SECURITY</b>	3DES Encryption, remote key injection, Master/Session and DUKPT Key Management
<b>POWER</b>	9.5V DC, 2.5A
<b>PHYSICAL</b>	(197x196x60mm) - (7.8x7.6x2.3") LxWxH
<b>BUTTONS</b>	10 alphanumeric keys, 3 function keys, 1 reset button, backlit
<b>SYSTEM</b>	Android OS 4.X
<b>WEIGHT</b>	770 g (1.7 lbs)
<b>OPERATION</b>	0°C ~ 50°C (32°F ~ 122°F), 10% -90% humidity (non-condensing)
<b>STORAGE</b>	-20°C ~ 60°C (-4°F ~ 140°F), 5% -95% humidity (non-condensing)

## Regulatory Conformance

Hereby, Advanced Mobile Payment Inc. declares that the radio equipment type [AMP 6700] is in compliance with Directive 2014/53/EU

The full text of the EU Declaration of Conformity is available on our website:

www.amobilepayment.com



Notice: This device may be used in each member state in EU

## FCC Caution:

Any Changes or modifications not expressly approved by the party responsible for compliance could void the user's authority to operate the equipment. This device complies with part 15 of the FCC Rules. Operation is subject to the following two conditions: (1) This device may not cause harmful interference, and (2) this device must accept any interference received, including interference that may cause undesired operation.

## IMPORTANT NOTE:

Note: This equipment has been tested and found to comply with the limits for a Class B digital device, pursuant to part 15 of the FCC Rules. These limits are designed to provide reasonable protection against harmful interference in a residential installation. This equipment generates, uses and can radiate radio frequency energy and, if not installed and used in accordance with the instructions, may cause harmful interference to radio communications. However, there is no guarantee that interference will not occur in a particular installation. If this equipment does cause harmful interference to radio or television reception, which can be determined by turning the equipment off and on, the user is encouraged to try to correct the interference by one or more of the following measures:

- Reorient or relocate the receiving antenna.
- Increase the separation between the equipment and receiver.
- Connect the equipment into an outlet on a circuit different from that to which the receiver is connected.
- Consult the dealer or an experienced radio/TV technician for help.

## Specific Absorption Rate (SAR) information

This equipment complies with FCC radiation exposure limits set forth for an uncontrolled environment. This equipment should be installed and operated with minimum distance 20cm between the radiator& your body.