

# AMP 8200

# 8 Series

---

## Quick Reference Guide

v 1.0

PQR-8200-1.0-E

## PROPRIETARY NOTICE

### Advanced Mobile Payment Inc.

Unit 401-403, 15 Wertheim Court

Richmond Hill, Ontario L4B 3H7 Canada

All pages of this document contain information proprietary to Advanced Mobile Payment Inc (AMP). This document shall not be duplicated, transmitted, used, or otherwise disclosed to anyone other than the organization or specific individuals to which this document is delivered, and then only for the purpose of evaluation of the AMP proposal. This restriction is applicable to all sheets of this document. AMP reserves the right to have the recipient return all copies of this document at any time.

© 2018 AMP Inc. All Rights Reserved

### Regulatory Conformance

Hereby, Advanced Mobile Payment Inc. declares that the radio equipment type [AMP 8200] is in compliance with Directive 2014/53/EU

The full text of the EU Declaration of Conformity is available on our website:

[www.ampmobilepayment.com](http://www.ampmobilepayment.com)



Notice: this device may be used in each member state in EU

## DOCUMENT PROPERTIES

### Information

<b>ID</b>	PQR-8200-1.0-E
<b>Title</b>	8 Series Quick Reference Guide
<b>Category</b>	AMP POS 8 Series - 8200
<b>Access Level</b>	General

### Version Control

<b>Version</b>	<b>Date</b>	<b>Summary of Change</b>	<b>Updated by</b>
1.0	Dec 2017	Initial version	R. Gibbs

### Supported Hardware & Software

<b>Version</b>	<b>Software Release</b>	<b>Supported Hardware Model</b>
1.0+	1.0	AMP POS 8 Series - 8200

# CONTENTS

1	Introduction	4
2	8 Series - 8200 Architecture	4
2.1	Front View	4
2.2	Back & Side View	5
3	General Precautions	6
4	Installing Terminal Battery	7
5	Installing SIM/SAM Card	7
6	Powering Device On/Off	9
7	Installing Printer Paper	9
8	Troubleshooting Common Problems	10
9	Technical Specifications	11
10	Regulatory Information	12

The following items should be found inside the original packaging:

- 8 Series POS terminal
- AC power supply and plug
- Micro USB cable
- Li-Ion battery
- Thermal paper roll
- Product Quick Reference Guide

## 1 Introduction

Maximize your point of sale capabilities by combining easy payment acceptance with customer desired features such as QR code scanning and value-added applications. With functions designed to improve the transaction flow for merchants like the charging base, expandable ports, handsfree scanning and simple touch interface, the AMP 8 Series delivers the latest technology without sacrificing the connectivity and security of a traditional POS. Running on a powerful Android-based OS, the 8 Series is easy to use and open to customization, providing a platform to integrate payment with external applications.

## 2 8 Series - 8200 Architecture

### 2.1 Front View

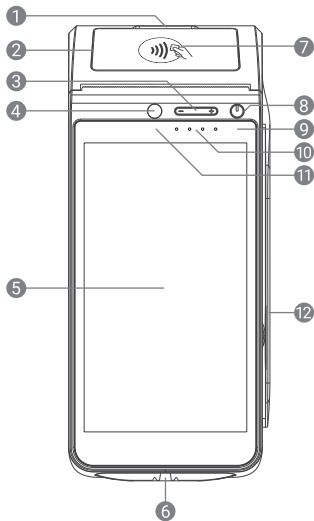

1	Printer paper roll door
2	Printer door release
3	Volume buttons
4	Front-facing camera
5	Touchscreen LCD
6	EMV chip insert slot
7	NFC contactless reader
8	On / Off button
9	Charging indicator light
10	LED indicators
11	Camera indicator light
12	Magstripe reader

## 2.2 Back & Side View

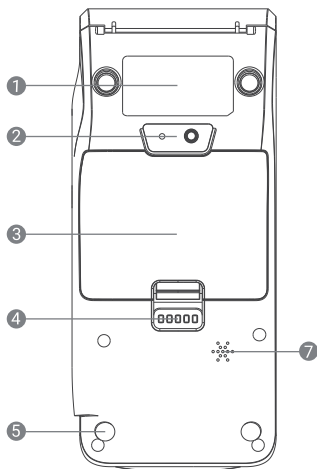

1	Identification label
2	Camera and 1D/2D scanner
3	Battery compartment cover
4	Charging contacts for base
5	Anti-slip rubber pads
6	Built-in speaker

1	Headphone jack
2	Micro USB port

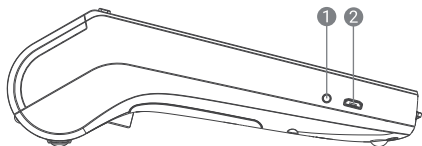

### 3 General Precautions

Basic care and consideration should be used when handling, operating or installing the 8 Series terminal. This is a secure device, with both physical and logical tamper protection, and **no** attempt should be made by the user to open or service the device in any way other than approved troubleshooting methods. Keep these basic guidelines in mind to prolong the longevity and functionality of your product:

- Use only the dedicated power supply and battery provided with the terminal to avoid damage to the device's electrical components
- Avoid spills or exposure to liquid, which could cause the terminal to short circuit
- Protect the terminal from impact, including: vibration, shaking, knocks, falling objects, being dropped, etc.
- Keep the terminal from environments that produce excessive dust, humidity, high or low temperatures, or electromagnetic fields
- While charging, do not attach or remove any components to avoid damage to the internal circuitry
- There are no user-serviceable internal parts or mechanisms, do not try to open, modify or repair the device
- This terminal contains a failsafe where all internal data will be erased immediately upon detection of tampering (such as opening the housing)
- If a fault occurs, immediately disconnect power supply, discontinue use and contact your service provider to request repairs and diagnostics
- When the battery reaches the end of its service life, it cannot be thrown in the garbage, instead it should be safely disposed of according to local hazardous disposal laws



## 4 Installing Terminal Battery

### Installing the battery

- Open the rear battery cover using the bottom tab to expose the battery compartment
- Connect the cable on the battery to the open connection port on the right side of the compartment, and securely insert the battery with the label tag facing upwards
- After installation, close the rear battery cover

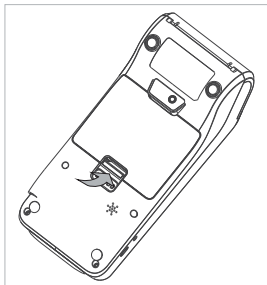

Open rear battery cover

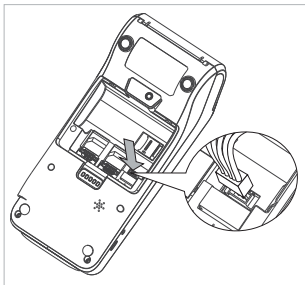

Install the battery

### NOTE

- When removing the battery, support its weight and gently unplug the connector to avoid damage to the wires or connections

## 5 Installing SIM/SAM Card

### Installing SIM/SAM cards

- Open the rear battery cover using the bottom tab and remove the battery



- With the exposed chip facing downward, and the angled corner oriented away from the slot, insert the card until it is seated right at the bottom of the slot
- After installing the card, connect the battery and close the rear battery cover

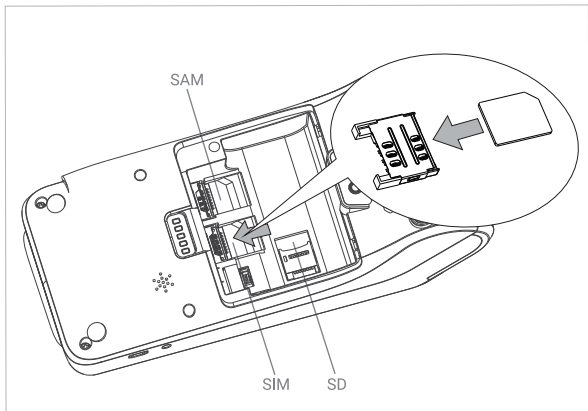

Install the SIM, SAM, or SD card

**NOTE**

- Ensure the terminal is powered off completely when attempting to install or uninstall a SIM/SAM card to avoid damaging the card or terminal
- Do not affix any labels or stickers to the SIM/SAM card, as they may cause the card to damage the receiver or become jammed inside of the device

## 6 Powering Device On/Off

### Powering On the device

First ensure that the battery is adequately charged, then press and hold the power key for at least six (6) seconds to turn the terminal on.

### Powering Off the device

While the terminal is on, press and hold the power key for at least two (2) seconds, and select "Shutdown" from the on-screen prompt, or hold the power key for eight (8) seconds to perform a forced shutdown.

## 7 Installing Printer Paper

### Installation of thermal receipt printer paper

- Pull up on the plastic release handle to pop open the paper holder lid
- Insert the thermal paper roll into the paper holder, ensuring the orientation and spool direction matches the below diagram
- After installation, ensure the paper holder lid is closed and securely in place

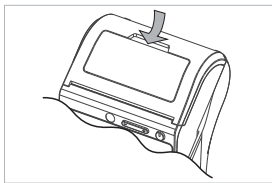

Open the printer paper door

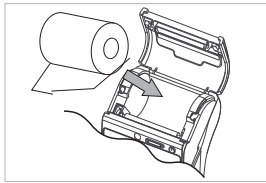

Insert the printer paper

### NOTE

- When installing paper, ensure thermal media side is facing print head
- Do not leave the printer without paper for extended periods of time, to prevent the rubber roller from sticking to the plate
- The heating plate operates at a high temperature, do not touch until it has fully cooled
- The manual paper cutter edge is sharp, keep clear to avoid injury

## 8 Troubleshooting Common Problems

If problems occur with the terminal, try these simple troubleshooting methods to correct the fault, or contact a service representative to further diagnose the issue.

Problem	Troubleshooting
Nothing displayed on screen	Ensure the battery is charged and properly connected
Unable to read card	Ensure that the slot is free of debris or foreign objects Swipe the card in both directions, and check if the error has been corrected Ensure the test card is operational, and test with an alternate card
Magnetic reader data read error	Swipe the card with constant speed, tight to the bottom edge of the slot Ensure the card strip is facing the screen and aligned properly in the slot Try swiping the card in the opposite direction
Chip card data read error	Ensure the chip portion is facing upwards, and is properly inserted into the slot Check the card for excessive scratches, dirt, or other damage
Contactless card data read error	Confirm that the card supports contactless communication Check whether the card is properly aligned above the contactless reader area
Communication error	Restart the terminal in order to re-establish communications Ensure that the SIM card is properly installed, and that the contacts are clean If using WiFi, ensure the connection is enabled on the terminal

If problems persist after completing these troubleshooting procedures, please contact your sales or service representative, **do not** attempt to open the terminal or make further repairs.



### Caution

RISK OF EXPLOSION IF BATTERY IS REPLACED WITH AN INCORRECT TYPE

## 9 Technical Specifications

Below are specifications relating to the overall capabilities of the AMP 8 Series, including optional or variable elements. To get the specifications for your individual terminals, please refer to your original sales order, or your sales representative for more information.

<b>PROCESSOR</b>	Dual processor, Quad-core A9 & high speed secure processor
<b>MEMORY</b>	8 or 16GB flash, 1GB DDR
<b>DISPLAY</b>	Full color 5.5" 720x1280 LCD, touch screen, signature capture, video capable
<b>CONNECTIVITY</b>	WiFi, Bluetooth 4.0, 2G, 3G, 4G, GPS, Micro USB OTG, headphone audio jack
<b>CERTIFICATION</b>	EMV 4.3e level I and II, NFC, D-Pass, Expresspay, Interac Flash, JCB Contactless, Mastercard Contactless, Visa Paywave, PCI PTS 5.X, CE
<b>CARD READERS</b>	Triple-track bi-directional magstripe reader, NFC contactless, ISO7811, ISO7812, ISO4443 A/B, Mifare, SIM, 2 SAM slots, SD card
<b>SECURITY</b>	3DES Encryption, Master/Session and DUKPT key management
<b>CAMERA</b>	Front & rear cameras, 1D / 2D scanning, flash, front camera active indicator
<b>PRINTER</b>	High speed , easy loading, 58mm paper width, 40 mm roll diameter
<b>BATTERY</b>	Rechargeable, 2600mAH, 7.2v,
<b>POWER</b>	5V DC, 2A
<b>DIMENSIONS</b>	(190x84x62mm) - (7.5" x 3.3" x 2.4") LxWxH
<b>BUTTONS</b>	1 Power button, volume controls
<b>SYSTEM</b>	Android OS 5.X
<b>WEIGHT</b>	450 g (0.99 lbs)
<b>OPERATION</b>	0°C ~ 50°C (32°F ~ 122°F), 10% -90% humidity (non-condensing)
<b>STORAGE</b>	-20°C ~ 60°C (-4°F ~ 140°F), 5% -95% humidity (non-condensing)
<b>PERIPHERAL</b>	Docking base - charging, expansion ports, handsfree countertop scanning

## 10 Regulatory Information

### Maximum Radio Frequency Power Levels

<b>BLE</b>	( 2402 - 2480 MHz ) : 0.1 dBm
<b>BT 3.0</b>	( 2402 - 2480 MHz ) : 5.4 dBm
<b>WiFi</b>	( 2412 - 2472 MHz ) : 15.49 dBm
<b>WiFi</b>	( 5.15 - 5.725 MHz ) : 14.61 dBm
<b>GSM 900</b>	30.91 dBm/1800 : 30.65 dBm
<b>WCDMA B1</b>	22.00 dBm/B8 : 21.39 dBm
<b>LTE B1</b>	21.49 dBm/B3 : 21.35 dBm/B7 : 21.72 dBm/B8 : 21.61 dBm/B20 : 21.56 dBm
<b>B38</b>	22.18 dBm/B40 : 22.41 dBm
<b>NFC</b>	

### Device SAR Limit

The SAR limit of Europe is 2.0 W/kg. The AMP 8200 Smart POS Terminal has also been tested against this SAR limit. The highest SAR value reported under this standard during product certification for use worn on the body is 1.003 W/kg. This device was tested for typical body-worn operations with the back of the handset kept 0 cm from the body. To maintain compliance with RF exposure requirements, use accessories that maintain a 0 cm separation distance between the user's body and the back of the handset. The use of belt clips, holsters and similar accessories should not contain metallic components in its assembly. The use of accessories that do not satisfy these requirements may not comply with RF exposure requirements, and should be avoided.

The device is restricted to indoor use when operated in Belgium (BE), Bulgaria (BG), Czech Republic (CZ), Denmark (DK), Germany (DE), Estonia (EE), Ireland (IE), Greece (EL), Spain (ES), France (FR), Croatia (HR), Italy (IT), Cyprus (CY), Latvia (LV), Lithuania (LT), Luxembourg (LU), Hungary (HU), Malta (MT), Netherlands (NL), Austria (AT), Poland (PL), Portugal (PT), Romania (RO), Slovenia (SI), Slovakia (SK), Finland (FI), Sweden (SE), United Kingdom (UK), Turkey (TR), Norway (NO), Switzerland (CH), Iceland (IS) and Liechtenstein (LI) using frequency in 5150MHz~5350MHz to reduce the potential for interference.

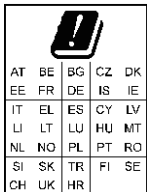

### FCC Statement

1. This device complies with Part 15 of the FCC Rules. Operation is subject to the following two conditions:

- (1) This device may not cause harmful interference.
- (2) This device must accept any interference received, including interference that may cause undesired operation.

Note: The grantee is not responsible for any changes or modifications not expressly approved by the party responsible for compliance. Such modifications could void the user's authority to operate the equipment.

**NOTE:** This equipment has been tested and found to comply with the limits for a Class B digital device, pursuant to part 15 of the FCC Rules. These limits are designed to provide reasonable protection against harmful interference in a residential installation.

This equipment generates uses and can radiate radio frequency energy and, if not installed and used in accordance with the instructions, may cause harmful interference to radio communications. However, there is no guarantee that interference will not occur in a particular installation. If this equipment does cause harmful interference to radio or television reception, which can be determined by turning the equipment off and on, the user is encouraged to try to correct the interference by one or more of the following measures:

- Reorient or relocate the receiving antenna.
- Increase the separation between the equipment and receiver.
- Connect the equipment into an outlet on a circuit different from that to which the receiver is connected.
- Consult the dealer or an experienced radio/TV technician for help

### RF Exposure Statement

The SAR limit of USA (FCC) is 1.6 W/kg averaged over one gram of tissue. Device types Smart POS Terminal (FCC ID: 2AKJB-AMP8200) has also been tested against this SAR limit. The highest SAR value reported under this standard during product certification when properly worn on the body is 1.022W/kg. This device was tested for typical body-worn operations with the back of the handset kept 0cm from the body. To maintain compliance with FCC RF exposure requirements, use accessories that maintain a 0cm separation distance between the user's body and the back of the handset. The use of belt clips, holsters and similar accessories should not contain metallic components in its assembly. The use of accessories that do not satisfy these requirements may not comply with FCC RF exposure requirements, and should be avoided.