

Industrial radio remote control systems

# **FLEX8EX**

## **Instruction Manual**



# Service Information

## Your New Radio Remote Control System

Thank you for your purchase of ARC Flex ES/EX radio remote control system. Without a doubt, our Flex ES/EX system is the ultimate solution for providing precise, undeterred, and safe control of your material.

If your product ever needs modification or service, please contact our representative in your country or at the following location:

### **World Headquarter:**

Advanced Radiotech Corporation  
288-1, Hsin Ya Road, Chien Chen District  
Kaohsiung, Taiwan

### **Telephone:**

+886 7 812 8112

### **Fax Number:**

+886 7 812 8119

### **Website:**

[www.advanced-radiotech.com](http://www.advanced-radiotech.com)

### **E-mails:**

[info@advanced-radiotech.com](mailto:info@advanced-radiotech.com)

[sales@advanced-radiotech.com](mailto:sales@advanced-radiotech.com)

All rights reserved. This notice applies to all copyrighted materials included with this product, including, but not limited to, this manual and software embodied within the product. This manual is intended for the sole use of the person(s) to whom it was provided, and any unauthorized distribution of the manual or dispersal of its contents is strictly forbidden. This manual may not be reproduced in whole or in part by any means whatsoever without the expressed written permission of ARC.

## PRODUCT MANUAL SAFETY INFORMATION

Advanced Radiotech Corporation (ARC) offers a broad range of radio remote control product for material handling applications. This manual has been prepared by ARC to provide information and recommendations for the installation, use, operation and service of ARC's material handling products and systems (ARC Products). Anyone who uses, operates, maintains, services, installs or owns ARC Products should know, understand, and follow the instructions and safety recommendations in this manual for ARC Products.

The recommendations in this manual do not take precedence over any of the following requirements relating to cranes, hoists lifting devices or other material handling equipment which use or include ARC Products:

- Instructions, manuals, and safety warnings of the manufacturers of the equipment where the radio system is used.
- Plant safety rules and procedures of the employers and the owners of facilities where the ARC Products are being used.
- Safety standards and practices for the industries in which ARC Products are used.

This manual does not include or address the specific instructions and safety warnings of these manufacturers or any of the other requirements listed above. It is the responsibility of the owners, users and operators of the ARC Products to know, understand and follow all of these requirements. It is the responsibility of the employer to make its employees aware of all of the above listed requirements and to make certain that all operators are properly trained. **No one should use ARC Products prior to becoming familiar with and being trained in these requirements and the instructions and safety recommendations in this manual.**

## WARRANTY INFORMATION

For information on ARC's product warranties, please contact ARC representative nearest to you or visit [www.advanced-radiotech.com](http://www.advanced-radiotech.com).

## FCC WARNINGS and CAUTIONS

- This equipment has been tested and found to comply with the limits for a Class B digital device, pursuant to part 15 of the FCC Rules. These limits are designed to provide reasonable protection against harmful interference in a residential installation. This equipment generates, uses and can radiate radio frequency energy and, if not installed and used in accordance with the instructions, may cause harmful interference to radio communications. However, there is no guarantee that interference will not occur in a particular installation. If this equipment does cause harmful interference to radio or television reception, which can be determined by turning the equipment off and on, the user is encouraged to try to correct the interference by one or more of the following measures:
  - Reorient or relocate the receiving antenna.
  - Increase the separation between the equipment and receiver.
  - Connect the equipment into an outlet on a circuit different from that to which the receiver is connected.
  - Consult the dealer or an experienced radio/TV technician for help.
- Any changes or modifications not expressly approved by the party responsible for compliance could void the authority to operate equipment.
- This device and its antenna must not be co-located or operating in conjunction with any other antenna or transmitter.
- End-users and installers must be provided with antenna installation instructions and transmitter operating conditions for satisfying RF exposure compliance.
- For product available in the USA/Canada market, only channel 1~141 can be operated. Selection of other channels is not possible

# Table of Contents

	Page
<b>1. Introduction</b>	<b>4</b>
<b>2. Radio Controlled Safety</b>	<b>5</b>
2.1. CRITICAL INSTALLATION CONSIDERATIONS	6
2.2. GENERAL	6
2.3. PERSONS AUTHORIZED TO OPERATE RADIO CONTROLLED CRANES	6
2.4. SAFETY INFORMATION AND RECOMMENDED TRAINING FOR RADIO CONTROLLED EQUIPMENT OPERATORS	7
2.5. TRANSMITTER UNIT	8
2.6. PRE-OPERATION TEST	8
2.7. BATTERIES	8
<b>3. General System Information</b>	<b>9</b>
3.1. Transmitter	9
3.1.1. External Illustration	9
3.2. Receiver	10
3.2.1. External Illustration	10
<b>4. Function Settings</b>	<b>11</b>
4.1. Transmitter	11
4.1.1. Transmitter Firmware Version	11
4.1.2. Transmitter Channel Settings	11
4.1.3. Remote Pairing	13
4.1.4. Transmitter Start Function Settings	14
4.1.5. Transmitter Inactivity Timer Settings	14
4.1.6. Infrared Programming	15
4.1.7. Pushbutton Function Settings	15
4.1.8. Transmitter Access Card (TAC) Settings	19
4.1.9. Display Frequency Band	20
4.1.10. Output Feedback Settings	20
4.1.11. Infrared Function Settings	20
4.1.12. Zero-G Sensor Settings	20
4.2. Receiver	21
4.2.1. Receiver Channel Settings	21
4.2.2. Output Relay Configurations	21
4.2.3. Dipswitch Settings	25
4.2.4. Jumper Settings	27
4.2.5. Voltage Settings	28
4.2.6. Indicator Light and Buzzer Installation	28
4.2.7. Other Function Output Relays Settings	28
4.2.8. System Channels Table	29
<b>5. Receiver Installation</b>	<b>30</b>
5.1. Output Relay Contact Diagrams	30
5.2. Pre-installation Precautions	31
5.3. Step-By-Step Installation	31
<b>6. Operating Procedures</b>	<b>34</b>
6.1. General Operation	34
6.2. Master/Master Tandem Operation (Tandem models)	35
6.3. Master/Slave Tandem Operation (Tandem models)	36
6.4. A/B Pushbutton Select Operation	38
6.5. A/B Rotary Select Operation (AB models)	38
6.6. Pitch & Catch Operation	38
6.7. Transmitter Access Card (TAC) Operation	38
6.8. Changing Batteries	39
6.9. Battery Charging	39
6.10. System Status Light Indications	40
6.10.1. Receiver Status Indications	41
6.10.2. Receiver Power Indications	41
6.10.3. Receiver COM Indications	41
<b>7. General Specifications</b>	<b>43</b>

# 1. Introduction

The **Flex ES/EX** radio remote control systems are designed for control of industrial equipment and machinery such as overhead traveling cranes, jib cranes, gantry cranes, tower cranes, electric hoists, winches, monorails, conveyor belts, mining equipment, and all other material handling equipment where wireless control is preferred.

Each **Flex ES/EX** system consists of a transmitter handset and a receiver unit. Other standard-equipped accessories include transmitter waist belt, vinyl pouch, pushbutton labels, LED labels, output cable and instruction manual CD.

List of notable features include:

- \* **Advanced Controls** – the system utilizes dual advanced microprocessor controls with 32bit CRC and Hamming Code, providing ultra fast, safe, precise, and error-free encoding and decoding.
- \* **Frequency Hopping RF Transceiver** – the system automatically search and lock onto a free and uninterrupted channel at every system startup or during operation when encountering radio interference. The system is also capable of two-way communication between the transmitter and receiver and as well as receiver to receiver with system status and relay output feedbacks.
- \* **Programmable Transmitter Access Card (TAC)** – the optional transmitter access card feature (TAC) further guard against any unauthorized personnel from operating the transmitter. The TAC can also be individually programmed unlocking any specific function or functions on the transmitter allowing a more experienced or qualified user to operate.
- \* **Zero-G Sensor Imbedded** – the transmitter is embedded with a Zero-G sensor to guard against any unintended control of the crane or equipment when transmitter is thrown or dropped.
- \* **Wireless Remote Pairing Function** – system information can be transferred wirelessly between two transmitters or between a transmitter and a receiver without the hassle of resetting the spares.
- \* **Reliable Pushbuttons** – the pushbuttons have gold plated contacts and are rated for more than two million press cycles. The defined snap-action steps provide positive tactile feedback even wearing gloves.
- \* **Low Power Consumption** – requires only two “AA” alkaline batteries for more than 100 hours of uninterrupted operation between replacements.
- \* **Durable Nylon and Fiberglass Composite Enclosures** – highly resistance to breakage and deformation even in the most abusive environments. The receiver enclosures and output cables are UL94-V0 rated. The transmitter and receiver enclosures are IP66 rated.
- \* **Full Compliance** – all systems are fully complied with the FCC Part-15 Rules and European Safety Standards.
- \* **Other Optional Accessories and Features** – transmitter magnet mount, transmitter belt clip, transmitter lanyard, transmitter rubber guard, miniature indicator light and buzzer, TAC, contact and contactless (inductive) charging stations, Ni-MH rechargeable batteries, tandem function, random access function, and many others.

## 2. Radio Controlled Safety

### WARNINGS and CAUTIONS

Throughout this document WARNING and CAUTION statements have been deliberately placed to highlight items critical to the protection of personnel and equipment.

**WARNING** – A warning highlights an essential operating or maintenance procedure, practice, etc. which if not strictly observed, could result in injury or death of personnel, or long term physical hazards. Warnings are highlighted as shown below:



**CAUTION** – A caution highlights an essential operating or maintenance procedure, practice, etc. which if not strictly observed, could result in damage to, or destruction of equipment, or loss of functional effectiveness. Cautions are highlighted as shown below:



### WARNINGS and CAUTIONS SHOULD NEVER BE DISREGARDED.

The safety rules in this section are not intended to replace any rules or regulations of any applicable local, state, or federal governing organizations. Always follow your local lockout and tagout procedure when maintaining any radio equipment. The following information is intended to be used in conjunction with other rules or regulations already in existence. It is important to read all of the safety information contained in this section before installing or operating the Radio Control System.

## 2.1. CRITICAL INSTALLATION CONSIDERATIONS



### WARNING

PRIOR TO INSTALLATION AND OPERATION OF THIS EQUIPMENT, READ AND DEVELOP AN UNDERSTANDING OF THE CONTENTS OF THIS MANUAL AND THE OPERATION MANUAL OF THE EQUIPMENT OR DEVICE TO WHICH THIS EQUIPMENT WILL BE INTERFACED. FAILURE TO FOLLOW THIS WARNING COULD RESULT IN SERIOUS INJURY OR DEATH AND DAMAGE TO EQUIPMENT.

ALL EQUIPMENT MUST HAVE A MAINLINE CONTACTOR INSTALLED AND ALL TRACKED CRANES, HOISTS, LIFTING DEVICES AND SIMILAR EQUIPMENT MUST HAVE A BRAKE INSTALLED. FAILURE TO FOLLOW THIS WARNING COULD RESULT IN SERIOUS INJURY OR DEATH AND DAMAGE TO EQUIPMENT.

AN AUDIBLE AND/OR VISUAL WARNING MEANS MUST BE PROVIDED ON ALL REMOTE CONTROLLED EQUIPMENT AS REQUIRED BY CODE, REGULATION, OR INDUSTRY STANDARD. THESE AUDIBLE AND/OR VISUAL WARNING DEVICES MUST MEET ALL GOVERNMENTAL REQUIREMENTS. FAILURE TO FOLLOW THIS WARNING COULD RESULT IN SERIOUS INJURY OR DEATH AND DAMAGE TO EQUIPMENT.

FOLLOW YOUR LOCAL LOCKOUT TAGOUT PROCEDURE BEFORE MAINTAINING ANY REMOTE CONTROLLED EQUIPMENT. ALWAYS REMOVE ALL ELECTRICAL POWER FROM THE CRANE, HOIST, LIFTING DEVICE OR SIMILAR EQUIPMENT BEFORE ATTEMPTING ANY INSTALLATION PROCEDURES. DE-ENERGIZE AND TAGOUT ALL SOURCES OF ELECTRICAL POWER BEFORE TOUCH-TESTING ANY EQUIPMENT. FAILURE TO FOLLOW THIS WARNING COULD RESULT IN SERIOUS INJURY OR DEATH AND DAMAGE TO EQUIPMENT.

THE DIRECT OUTPUTS OF THIS PRODUCT ARE NOT DESIGNED TO INTERFACE DIRECTLY TO TWO STATE SAFETY CRITICAL MAINTAINED FUNCTIONS, I.E., MAGNETS, VACUUM LIFTS, PUMPS, EMERGENCY EQUIPMENT, ETC. A MECHANICALLY LOCKING INTERMEDIATE RELAY SYSTEM WITH SEPARATE POWER CONSIDERATIONS MUST BE PROVIDED. FAILURE TO FOLLOW THIS WARNING COULD RESULT IN SERIOUS INJURY OR DEATH OR DAMAGE TO EQUIPMENT.

## 2.2. GENERAL

Radio controlled material handling equipment operates in several directions. Cranes, hoists, lifting devices and other material handling equipment can be large, and operate at high speeds. Quite frequently, the equipment is operated in areas where people are working in close proximity to the material handling equipment. **The operator must exercise extreme caution at all times.** Workers must constantly be alert to avoid accidents. The following recommendations have been included to indicate how careful and thoughtful actions may prevent injuries, damage to equipment, or even save a life.

## 2.3. PERSONS AUTHORIZED TO OPERATE RADIO CONTROLLED CRANES

Only properly trained persons designated by management should be permitted to operate radio controlled equipment.

Radio controlled cranes, hoists, lifting devices and other material handling equipment should not be operated by any person who cannot read or understand signs, notices and operating instructions that pertain to the equipment.

Radio controlled equipment should not be operated by any person with insufficient eyesight or hearing or by any person who may be suffering from a disorder or illness, is taking any medication that may cause loss of equipment control, or is under the influence of alcohol or drugs.

## 2.4. SAFETY INFORMATION AND RECOMMENDED TRAINING FOR RADIO CONTROLLED EQUIPMENT OPERATORS

Anyone being trained to operate radio controlled equipment should possess as a minimum the following knowledge and skills before using the radio controlled equipment.

### The operator should:

- have knowledge of hazards pertaining to equipment operation
- have knowledge of safety rules for radio controlled equipment
- have the ability to judge distance of moving objects
- know how to properly test prior to operation
- be trained in the safe operation of the radio transmitter as it pertains to the crane, hoist, lifting device or other material handling equipment being operated
- have knowledge of the use of equipment warning lights and alarms
- have knowledge of the proper storage space for a radio control transmitter when not in use
- be trained in transferring a radio control transmitter to another person
- be trained how and when to report unsafe or unusual operating conditions
- test the transmitter emergency stop and all warning devices prior to operation; testing should be done on each shift, without a load
- be thoroughly trained and knowledgeable in proper and safe operation of the crane, hoist, lifting device, or other material handling equipment that utilizes the radio control
- know how to keep the operator and other people clear of lifted loads and to avoid “pinch” points
- continuously watch and monitor status of lifted loads
- know and follow cable and hook inspection procedures
- know and follow the local lockout and tagout procedures when servicing radio controlled equipment
- know and follow all applicable operating and maintenance manuals, safety procedures, regulatory requirements, and industry standards and codes

### The operator shall not:

- lift or move more than the rated load
- operate the material handling equipment if the direction of travel or function engaged does not agree with what is indicated on the controller
- use the crane, hoist or lifting device to lift, support or transport people
- lift or carry any loads over people
- operate the crane, hoist or lifting device unless all persons, including the operator, are and remain clear of the supported load and any potential pinch points
- operate a crane, hoist or lifting device when the device is not centered over the load
- operate a crane, hoist or lifting device if the chain or wire rope is not seated properly in the sprockets, drum or sheave



- operate any damaged or malfunctioning crane, hoist, lifting device or other material handling equipment
- change any settings or controls without authorization and proper training
- remove or obscure any warning or safety labels or tags
- leave any load unattended while lifted
- leave power on the radio controlled equipment when the equipment is not in operation
- operate any material handling equipment using a damaged controller because the unit may be unsafe
- operate manual motions with other than manual power
- operate radio controlled equipment when low battery indicator is on



## WARNING

THE OPERATOR SHOULD NOT ATTEMPT TO REPAIR ANY RADIO CONTROLLER. IF ANY PRODUCT PERFORMANCE OR SAFETY CONCERNS ARE OBSERVED, THE EQUIPMENT SHOULD IMMEDIATELY BE TAKEN OUT OF SERVICE AND BE REPORTED TO THE SUPERVISOR. DAMAGED AND INOPERABLE RADIO CONTROLLER EQUIPMENT SHOULD BE RETURNED TO MAGNETEK FOR EVALUATION AND REPAIR. FAILURE TO FOLLOW THIS WARNING COULD RESULT IN SERIOUS INJURY OR DEATH AND DAMAGE TO EQUIPMENT.

## 2.5. TRANSMITTER UNIT

Transmitter switches should never be mechanically blocked ON or OFF. When not in use, the operator should turn the transmitter OFF. A secure storage space should be provided for the transmitter unit, and the transmitter unit should always be placed there when not in use. This precaution will help prevent unauthorized people from operating the material handling equipment.

Spare transmitters should be stored in a secure storage space and only removed from the storage space after the current transmitter in use has been turned OFF, taken out of the service area and secured.

## 2.6. PRE-OPERATION TEST

**At the start of each work shift, or when a new operator takes control of the crane, operators should do, as a minimum, the following steps before making lifts with any crane or hoist:**

Test all warning devices.

Test all direction and speed controls.

Test the transmitter emergency stop.

## 2.7. BATTERIES



## WARNING

KNOW AND FOLLOW PROPER BATTERY HANDLING, CHARGING AND DISPOSAL PROCEDURES. IMPROPER BATTERY PROCEDURES CAN CAUSE BATTERIES TO EXPLODE OR DO OTHER SERIOUS DAMAGE. FAILURE TO FOLLOW THIS WARNING COULD RESULT IN SERIOUS INJURY OR DEATH AND DAMAGE TO EQUIPMENT.

# 3. General System Information

## 3.1. Transmitter

### 3.1.1. External Illustration

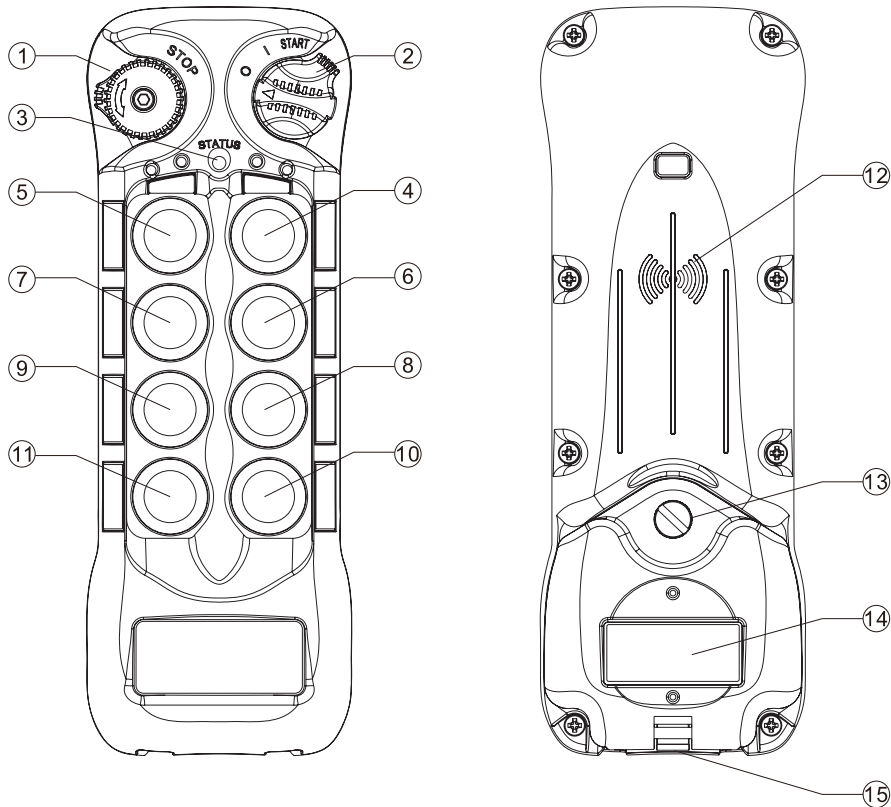

- |    |                      |     |  |
|----|----------------------|-----|--|
| 1. | STOP Button          | 9.  | Pushbutton 6 (PB6)                     |
| 2. | Power Key Switch     | 10. | Pushbutton 7 (PB7)                     |
| 3. | Status LED Indicator | 11. | Pushbutton 8 (PB8)                     |
| 4. | Pushbutton 1 (PB1)   | 12. | TAC* and Inductive Charging Slot       |
| 5. | Pushbutton 2 (PB2)   | 13. | Battery Cover Screw                    |
| 6. | Pushbutton 3 (PB3)   | 14. | System Information                     |
| 7. | Pushbutton 4 (PB4)   | 15. | Lanyard and Waist Belt Attachment Slot |
| 8. | Pushbutton 5 (PB5)   |     |  |

\* Transmitter Access Card

**Note:** Flex 8ES-AB/8EX-AB and 8ES-T/8EX-T models are with A/B/A+B rotary switch on PB8 slot.

## 3.2. Receiver

### 3.2.1. External Illustration

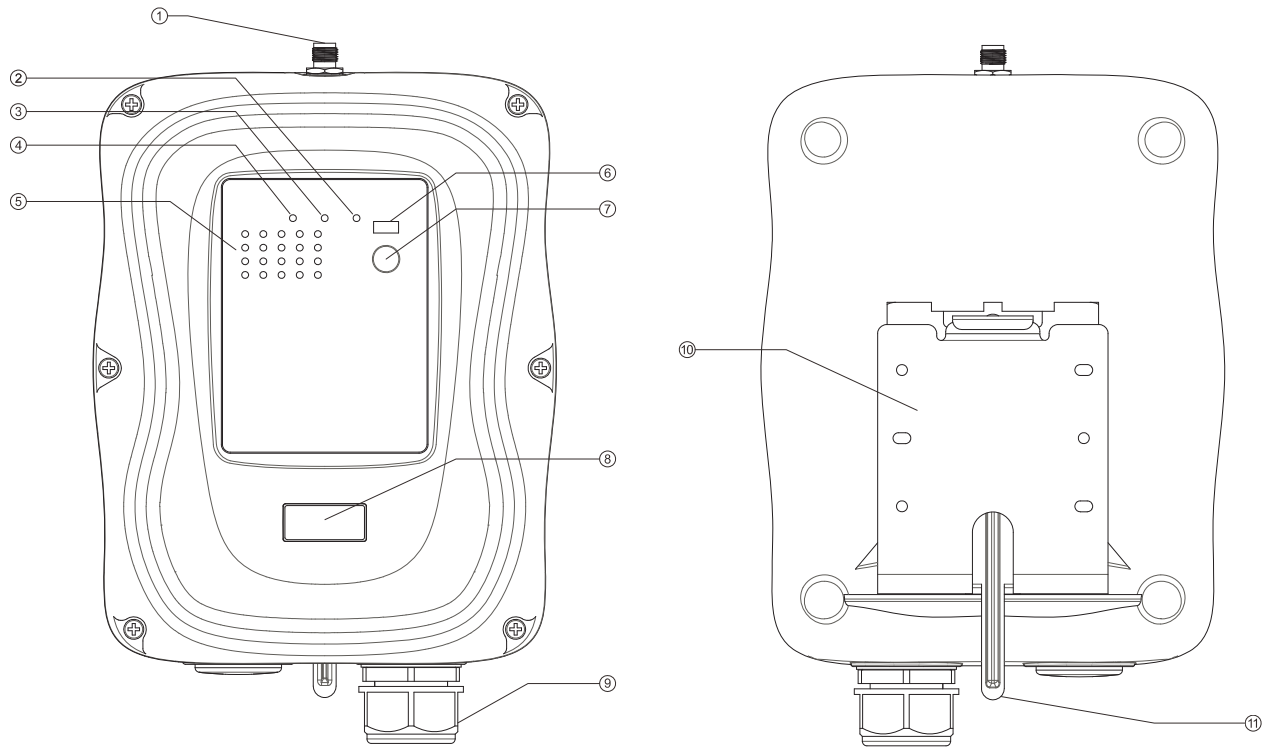

- |    |                                  |     |                          |
|----|----------------------------------|-----|--------------------------|
| 1. | External Antenna Port (optional) | 7.  | Remote Pairing Button    |
| 2. | COM LED Indicator                | 8.  | System Information       |
| 3. | Status LED Indicator             | 9.  | Cord Grip                |
| 4. | Power LED Indicator              | 10. | Mounting Bracket         |
| 5. | Output Relay LED Indicators      | 11. | Mounting Bracket Release |
| 6. | Infrared Sensors                 |     |                          |

# 4. Function Settings

## 4.1. Transmitter

### 4.1.1. Transmitter Firmware Version

- 1) Rotate the power switch key to OFF ( 0 ) position.
- 2) With the STOP button elevated, press and hold PB1 and PB3 at the same time.
- 3) Rotate the power switch key to ON ( 1 ) position.
- 4) Let go PB1 and PB3 at the same time. The Status LED displays firmware version with red, green and orange blinks.
- 5) Exit Firmware Version mode by rotate the power switch key to OFF ( 0 ) position.

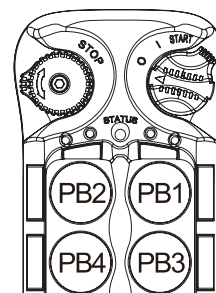

### 4.1.2. Transmitter Channel Settings

#### A. Unassigned Channel Scheme (no preset system channel)

When both transmitter and receiver is set to unassigned channel scheme (no preset channel) the system automatically search and lock onto a free and uninterrupted channel at every transmitter startup. Pitch & Catch, t-type, and multi-receiver configurations can not set to unassigned channel scheme.

- 1) Rotate the power switch key to OFF ( 0 ) position.
- 2) With the STOP button elevated, press and hold PB1 and PB2 at the same time.
- 3) Rotate the power switch key to ON ( 1 ) position.
- 4) Let go PB1 and PB2 at the same time (entered Channel Setting mode). The Status LED displays current channel setting with red and green blinks. A green blink represents the tens (+10) and a red blink represents the units (+1). For example, 1 green blink followed by 5 red blinks is channel 15. Channel unassigned is represented by constant orange on the Status LED.
- 5) Change transmitter channel to “channel unassigned” by pressing PB4 one time (Status LED displays constant orange).
- 6) Transfer “channel unassigned” setting to the receiver by rotate and hold the power switch key at START position until the Status LED turns to constant green (transfer complete). Turn off the transmitter power if constant green is not shown on the Status LED after more than 10 seconds (transfer incomplete); the transmitter will revert back to its previous channel setting. Make sure the receiver power is turned on and within the operating distance during the entire process. When transmitter is set to “channel unassigned” the receiver must also set to “channel unassigned” in order for the entire system to work.
- 7) Exit Channel Setting mode by rotate the power switch key to OFF ( 0 ) position.

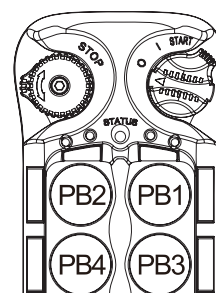

## B. Assigned Channel Scheme (preset system channel)

Both transmitter and receiver is assigned with a matching preset channel (channel 01~141). Pitch & Catch, t-type, and multi-receiver configurations must set to assigned channel scheme.

- 1) Rotate the power switch key to OFF ( 0 ) position.
- 2) With the STOP button elevated, press and hold PB1 and PB2 at the same time.
- 3) Rotate the power switch key to ON ( I ) position.
- 4) Let go PB1 and PB2 at the same time (entered Channel Setting mode). The Status LED displays current channel setting with red and green blinks. A green blink represents the tens (+10) and a red blink represents the units (+1). For example, 1 green blink followed by 5 red blinks is channel 15. Channel unassigned is represented by constant orange on the Status LED.
- 5) Change transmitter channel by pressing PB1 to increment the units (+1) and PB2 to increment the tens (+10). For example, press PB2 two times and then PB1 four times is channel 24 (Status LED blinks 2 greens and 4 reds).
- 6) Transfer the newly selected channel to the receiver by rotate and hold the power switch key at START position until the Status LED turns to constant green (transfer complete). Turn off the transmitter power if constant green is not shown on the Status LED after more than 10 seconds (transfer incomplete); the transmitter will revert back to its previous channel setting. Make sure the receiver power is turned on and within the operating distance during the entire process. **Skip step 6 if changing receiver channel is not required.**
- 7) Exit Channel Setting mode by rotate the power switch key to OFF ( 0 ) position.

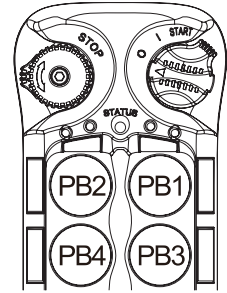

**Note:** When selecting a new channel, make sure each button press does not exceed 3 seconds.

### Important Note:

Step 6 illustrated above is strictly required if you are intending to change the entire system channel (both transmitter and receiver). The entire system no longer works if step 6 is skipped because the transmitter and receiver channels are now different (new vs. old). In this case you would have to redo step 1~4 and step 6 to transfer the newly selected transmitter channel to the receiver.

### 4.1.3. Remote Pairing

#### A. Transmitter-to-Transmitter Pairing:

- 1) Rotate the power switch key to OFF ( 0 ) position.
- 2) With the STOP button elevated, press and hold PB1 and PB3 at the same time.
- 3) Rotate the power switch key to ON ( 1 ) position.
- 4) Let go PB1 and PB3 at the same time (entered Remote Pairing mode). The Status LED displays firmware version with red, green and orange blinks.
- 5) Output data (original transmitter) by press and hold PB2 (Status LED off).
- 6) Receive data (new transmitter) by press and hold PB1 (Status LED blinks green).
- 7) When the Status LED (receiving data end) turns to constant green while both pushbuttons are still pressed down the pairing is completed.
- 8) Exit Remote Pairing mode by rotate the power switch key to OFF ( 0 ) position.

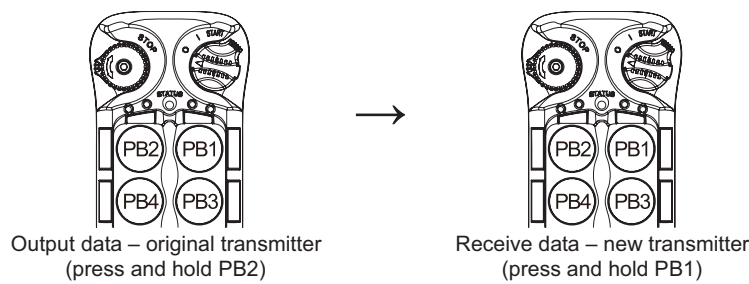
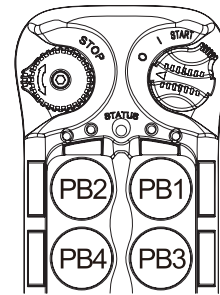

**Note:** During remote pairing make sure the distance between the two transmitters is within 1 meter.

#### B. Receiver-to-Transmitter Pairing:

**JP8 Open Method:** After the transmitter enters the Remote Pairing mode, output receiver data by press and hold the PAIRING button located on the receiver cover and receive data by press and hold PB3 on the transmitter, both at the same time. When the transmitter Status LED turns to constant green while both pushbuttons are still pressed down the pairing is completed.

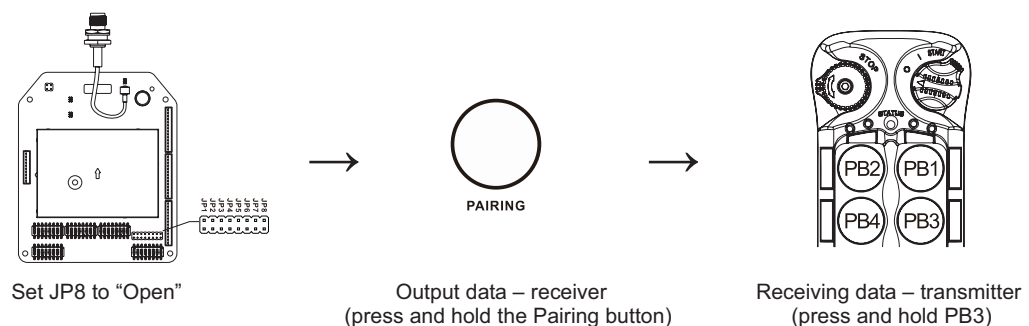

**JP8 Short Method (press Pairing button not required):** After the transmitter enters the Remote Pairing mode, press and hold PB3 on the transmitter until the Status LED turns to constant green the pairing is completed. **Make sure the pairing process is executed within distance of 10 meters from one another and no other active receivers nearby. During pairing process the receiver MAIN relays must be deactivated (relay open). For tandem systems make sure the receiver is not locked to any of its existing transmitters.**

### 4.1.4. Transmitter Start Function Settings

When transmitter goes into sleep mode the system is temporarily deactivated (MAIN relays opened). Execute the START command or press any pushbutton to wake up the system (MAIN relays closed).

	Dipswitch Settings	Function
1	xxxxxxxx0	START Reactivation
2	xxxxxxxx1	Any Button Reactivation

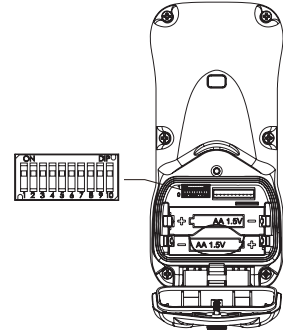

### 4.1.5. Transmitter Inactivity Timer Settings

Set how long the system enters the sleep mode when the transmitter is not in use (pushbutton not pressed). When transmitter goes into sleep mode the receiver MAIN relays are deactivated.

	Dipswitch Settings	Time		Dipswitch Settings	Time
1	xxx000xxxx	1 minute	5	xxx100xxxx	10 minutes
2	xxx001xxxx	20 seconds	6	xxx101xxxx	30 minutes
3	xxx010xxxx	3 minutes	7	xxx110xxxx	60 minutes
4	xxx011xxxx	5 minutes	8	xxx111xxxx	Constant On (sleep mode disabled)

## 4.1.6. Infrared Programming

Other custom functions and settings not listed in this manual can be programmed via the infrared IR programmer unit, such as the system serial number, frequency range, TAC, relay output status feedback, new and updated functions, and many others. Please contact ARC representative for more details.

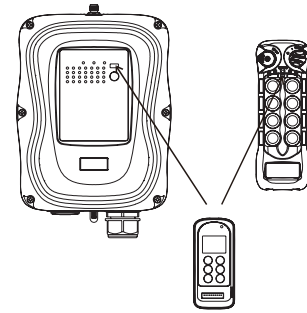

## 4.1.7. Pushbutton Function Settings

- 1) Rotate the power switch key to OFF ( 0 ) position..
- 2) With the STOP button elevated, press and hold PB3 and PB4 at the same time.
- 3) Rotate the power switch key to ON ( I ) position.
- 4) Let go PB3 and PB4 at the same time (entered Pushbutton Function mode).
- 5) The Status LED displays current pushbutton function setting with orange, green and red blinks. An orange blink represents the hundreds (+100), a green blink represents the tens (+010) and a red blink represents the units (+001). For example, 1 orange blink followed by 2 green blinks and 5 red blinks is pushbutton function no. **125**. Pushbutton function number with "0" is represented by no orange, green or red blink. For example, 1 orange blink followed by 5 red blinks is pushbutton function no. **105**.
- 6) Set pushbutton function number by pressing PB3 to increment the hundreds (+100), PB2 to increment the tens (+010), PB1 to increment the units (+001), and PB4 to reset (000 - constant orange). For example, press PB3 one time, PB2 four times, PB1 six times is pushbutton function no. **146** (Status LED blinks 1 orange, 4 greens and 6 reds)
- 7) Exit Pushbutton Function mode by rotate the power switch key to OFF ( 0 ) position.

### 4.1.7.1. Toggled Pushbutton with LED Indication – Standard Right/Left Pushbutton Configuration

Set pushbutton toggled function (latching output relay) with LED indications. LED 1 ~ 4 shown inside the shaded box illustrates which LED on the transmitter lights up when the designated pushbutton is pressed.

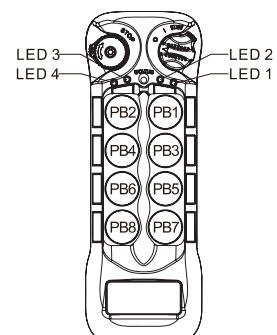

Function Number	Display Type	PB1	PB2	PB3	PB4
1	1 Red	Normal	Normal	Normal	LED 4
2	2 Reds	Normal	Normal	LED 3	LED 4
3	3 Reds	Normal	LED 2	LED 3	LED 4
4	4 Reds	LED 1	LED 2	LED 3	LED 4



Function Number	Display Type	PB5	PB6	PB7	PB8
5	5 Reds	Normal	Normal	Normal	LED 4
6	6 Reds	Normal	Normal	LED 3	LED 4
7	7 Reds	Normal	LED 2	LED 3	LED 4
8	8 Reds	LED 1	LED 2	LED 3	LED 4

\* PB1...PB8 → Pushbutton number.

\* Normal → Normal momentary contact.

\* LED 1 ~ LED 4 → Pushbutton toggled function with designated LED indication.

#### 4.1.7.2. A/B Pushbutton Select with LED Indication – Standard Right/Left Pushbutton Configuration

There are 4 different types of A/B selector sequence available. Choose one that is most suitable for your application. Refer to section 5.1 output relay connections.

Type-A selector sequence : A → B

Type-B selector sequence : Off → A → B

Type-C selector sequence : A → B → A+B

Type-D selector sequence : Off → A → B → A+B

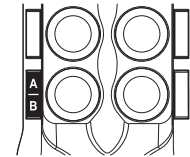

Function Number	Display Type	PB5	PB6	PB7	PB8
47	4 Greens + 7 Reds	Normal	Normal	A/1&2	Normal
48	4 Greens + 8 Reds	Normal	Normal	B/1&2	Normal
49	4 Greens + 9 Reds	Normal	Normal	C/1&2	Normal
50	5 Greens	Normal	Normal	D/1&2	Normal
51	5 Greens + 1 Red	Normal	Normal	Normal	A/3&4
52	5 Greens + 2 Reds	Normal	Normal	Normal	B/3&4
53	5 Greens + 3 Reds	Normal	Normal	Normal	C/3&4
54	5 Greens + 4 Reds	Normal	Normal	Normal	D/3&4
55	5 Greens + 5 Reds	Normal	Normal	A/1&2	A/3&4
56	5 Greens + 6 Reds	Normal	Normal	A/1&2	B/3&4
57	5 Greens + 7 Reds	Normal	Normal	A/1&2	C/3&4
58	5 Greens + 8 Reds	Normal	Normal	A/1&2	D/3&4
59	5 Greens + 9 Reds	Normal	Normal	B/1&2	B/3&4
60	6 Greens	Normal	Normal	B/1&2	C/3&4
61	6 Greens + 1 Red	Normal	Normal	B/1&2	D/3&4
62	6 Greens + 2 Reds	Normal	Normal	C/1&2	C/3&4
63	6 Greens + 3 Reds	Normal	Normal	C/1&2	D/3&4
64	6 Greens + 4 Reds	Normal	Normal	D/1&2	D/3&4

\* PB5...PB8 → Pushbutton number.

\* Normal → Normal momentary contact.

\* A/1&2 ~ D/3&4 → A/B pushbutton select function with designated LED indication.

### 4.1.7.3. Toggled Pushbutton with LED Indication – Inline Top/Bottom Pushbutton Configuration

Set pushbutton toggled function (latching output relay) with LED indications. LED 1 ~ 4 shown inside the shaded box illustrates which LED on the transmitter lights up when the designated pushbutton is pressed. Refer to section 4.2.4 JP4/JP5 inline jumper settings.

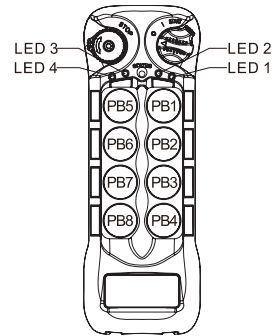

Function Number	Display Type	PB1	PB2	PB3	PB4
1	1 Red	Normal	Normal	Normal	LED 4
17	1 Green + 7 Reds	Normal	Normal	LED 3	LED 4
18	1 Green + 8 Reds	Normal	LED 2	LED 3	LED 4
19	1 Green + 9 Reds	LED 1	LED 2	LED 3	LED 4

Function Number	Display Type	PB5	PB6	PB7	PB8
5	5 Reds	Normal	Normal	Normal	LED 4
20	2 Greens	Normal	Normal	LED 3	LED 4
21	2 Greens + 1 Red	Normal	LED 2	LED 3	LED 4
22	2 Greens + 2 Reds	LED 1	LED 2	LED 3	LED 4

\* PB1...PB8 → Pushbutton number.

\* Normal → Normal momentary contact.

\* LED 1 ~ LED 4 → Pushbutton toggled function with designated LED indication.

#### 4.1.7.4. A/B Pushbutton Select with LED Indication – Inline Top/Bottom Pushbutton Configuration

There are 4 different types of A/B selector sequence available. Choose one that is most suitable for your application. Refer to section 4.2.4 JP4/JP5 inline jumper settings and section 5.1 output relay connections.

Type-A selector sequence : A → B

Type-B selector sequence : Off → A → B

Type-C selector sequence : A → B → A+B

Type-D selector sequence : Off → A → B → A+B

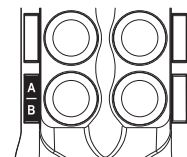

Function Number	Display Type	PB5	PB6	PB7	PB8
115	1 orange + 1 Green + 5 Reds	Normal	Normal	A/1&2	Normal
116	1 orange + 1 Green + 6 Reds	Normal	Normal	B/1&2	Normal
117	1 orange + 1 Green + 7 Reds	Normal	Normal	C/1&2	Normal
118	1 orange + 1 Green + 8 Reds	Normal	Normal	D/1&2	Normal
51	5 Greens + 1 Red	Normal	Normal	Normal	A/3&4
52	5 Greens + 2 Reds	Normal	Normal	Normal	B/3&4
53	5 Greens + 3 Reds	Normal	Normal	Normal	C/3&4
54	5 Greens + 4 Reds	Normal	Normal	Normal	D/3&4
119	1 orange + 1 Green + 9 Reds	Normal	Normal	A/1&2	A/3&4
120	1 orange + 2 Greens	Normal	Normal	A/1&2	B/3&4
121	1 orange + 2 Greens + 1 Red	Normal	Normal	A/1&2	C/3&4
122	1 orange + 2 Greens + 2 Reds	Normal	Normal	A/1&2	D/3&4
123	1 orange + 2 Greens + 3 Reds	Normal	Normal	B/1&2	B/3&4
124	1 orange + 2 Greens + 4 Reds	Normal	Normal	B/1&2	C/3&4
125	1 orange + 2 Greens + 5 Reds	Normal	Normal	B/1&2	D/3&4
126	1 orange + 2 Greens + 6 Reds	Normal	Normal	C/1&2	C/3&4
127	1 orange + 2 Greens + 7 Reds	Normal	Normal	C/1&2	D/3&4
128	1 orange + 2 Greens + 8 Reds	Normal	Normal	D/1&2	D/3&4

\* PB5...PB8 → Pushbutton number.

\* Normal → Normal momentary contact.

\* A/1&2 ~ D/3&4 → A/B pushbutton select function with designated LED indication.

## 4.1.8. Transmitter Access Card (TAC) Settings

Follow the instruction below on how to program the TAC into the transmitter. The infrared IR programmer unit is required to complete the programming. Please contact ARC representative for more details.

- 1) Rotate the power switch key to OFF ( 0 ) position.
- 2) With the STOP button elevated, press and hold PB1, PB2, PB3 and PB4 at the same time.
- 3) Rotate the power switch key to ON ( 1 ) position.
- 4) Let go PB1, PB2, PB3 and PB4 at the same time, the Status LED displays orange fast blinks (entered TAC mode).
- 5) Placed the access card over the RFID marking located on the backside of the transmitter.
- 6) Status LED with 1 second green means the access card is being programmed into the transmitter.
- 7) Status LED with 1 second orange means the access card is already programmed into the transmitter.
- 8) Status LED with 1 second red means unable to store any more access cards. Each transmitter can only store up to 16 access cards.
- 9) Use the infrared IR programmer unit to extract all access card information stored inside the transmitter for further programming. Other than restricting any unauthorized personnel from using the transmitter, it can also be individually programmed unlocking any specific function or functions on the transmitter allowing a more experienced or qualified user to operate, such as the magnet lift, tandem operation, entering restricted areas, etc...
- 10) Exit TAC mode by rotate the power switch key to OFF ( 0 ) position.

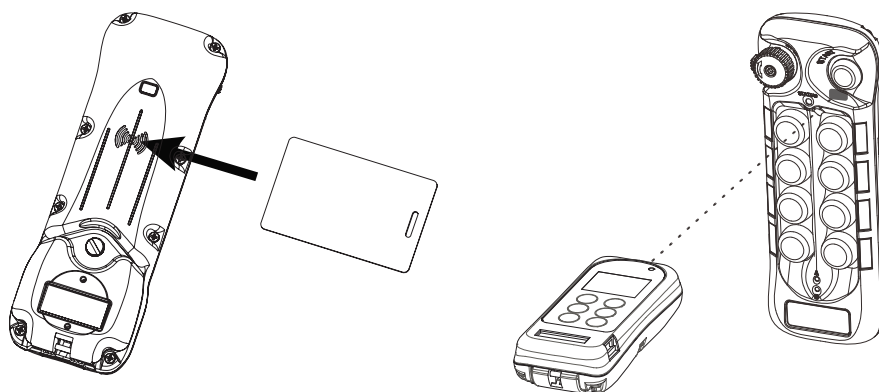
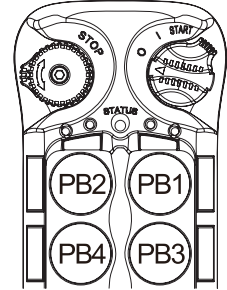

### 4.1.9. Display Frequency Band

- 1) Rotate the power switch key to OFF ( 0 ) position.
- 2) With the STOP button elevated, press and hold PB1 and PB3 at the same time.
- 3) Rotate the power switch key to ON ( 1 ) position.
- 4) Let go PB2 and PB4 at the same time (entered Frequency Band Display mode).
- 5) The Status LED displays the preset transmitter frequency band with orange, green and red blinks. An orange blink represents the hundreds (+100), a green blink represents the tens (+010) and a red blink represents the units (+001). For example, 4 orange blinks followed by 3 green blinks and 3 red blinks is 433MHz.
- 6) Exit Frequency Band Display mode by rotate the power switch key to OFF ( 0 ) position.

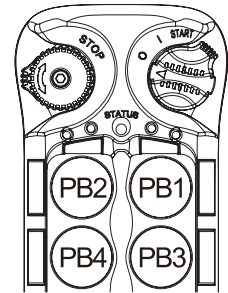

### 4.1.10. Output Feedback Settings

Up to 4 assignable relay outputs can be programmed into the system and feedback to the transmitter LED indicators during operation. These settings require using the infrared IR programmer unit. Please contact ARC representative for more details.

### 4.1.11. Infrared Function Settings

The transmitter is embedded with infrared sensors for infrared start function. These settings require using the infrared IR programmer unit. Please contact ARC representative for more details.

### 4.1.12. Zero-G Sensor Settings

The transmitter is embedded with a Zero-G sensor to guard against any unintended control of the crane or equipment when transmitter is thrown or dropped. When triggered, the receiver MAIN relays are deactivated with the exception of the horn output that can be assigned to any of the Function output relays (K25, K26 or K30). This horn output setting requires the infrared IR programmer unit. Please contact ARC representative for more details.

## 4.2. Receiver

### 4.2.1. Receiver Channel Settings

Set the receiver channel by configuring the channel dipswitch located on the decoder board, only the first 6 dip positions are used for channel programming. The system channels table on section 4.2.8 illustrates which dipswitch setting corresponds to which channel. Once the receiver channel is altered do make sure to change the transmitter channel as well. The channel on both transmitter and receiver must be identical in order for the system to work (refer to section 4.1.2 part B). When set to all zeros (000000), the receiver becomes unassigned channel scheme (refer to section 4.1.2 part A).

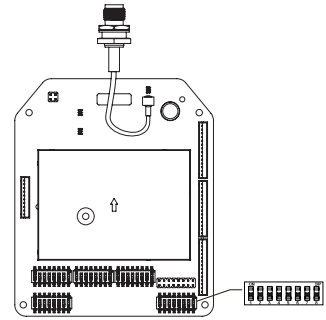

**Example:**

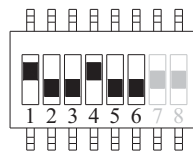

Top position → "1"  
Bottom position → "0"

The above dipswitch setting "1 0 0 1 0 0" corresponds to "channel 36" in the system channels table on section 4.2.8.

### 4.2.2. Output Relay Configurations

#### 4.2.2.1. Output Relay Types

- 2 output relays per motion – single speed only**  
Output relays with Forward (F) and Reverse (R) 1<sup>st</sup> speed only.

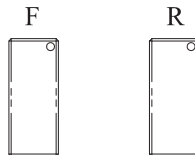

- 3 output relays per motion – shared 2<sup>nd</sup> speed output relay**  
Output relays with Forward 1<sup>st</sup> speed (F1), Reverse 1<sup>st</sup> speed (R1) and Forward/Reverse 2<sup>nd</sup> speed (F/R2). Forward and Reverse 2<sup>nd</sup> speed (F/R2) shared the same output relay.

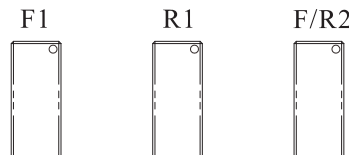

- 4 output relays per motion – separate 1<sup>st</sup> and 2<sup>nd</sup> speed output relays**  
Output relays with Forward 1<sup>st</sup> speed (F1), Reverse 1<sup>st</sup> speed (R1), Forward 2<sup>nd</sup> speed (F2) and Reverse 2<sup>nd</sup> speed (R2). Forward and Reverse 2<sup>nd</sup> speed are separate output relays.

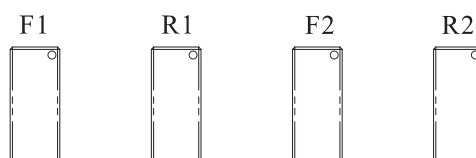

## 4.2.2.2. Output Relay Actions at 2<sup>nd</sup> Speed (Flex 8EX only)

- 3 output relays configuration with Closed/Closed contact at 2<sup>nd</sup> speed**  
F1 (or R1) output relay closed at 1<sup>st</sup> speed and F1 + F/R2 (or R1 + F/R2) output relays closed at 2<sup>nd</sup> speed. Refer to section 4.2.3.1 on how to set to this function.

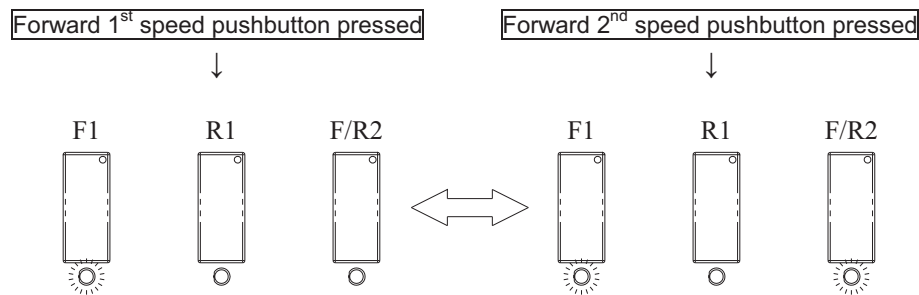

- 4 output relays configuration with Opened/Closed contact at 2<sup>nd</sup> speed**  
F1 (or R1) output relay closed at 1<sup>st</sup> speed and F2 (or R2) output relay closed at 2<sup>nd</sup> speed. Refer to section 4.2.3.1 on how to set to this function.

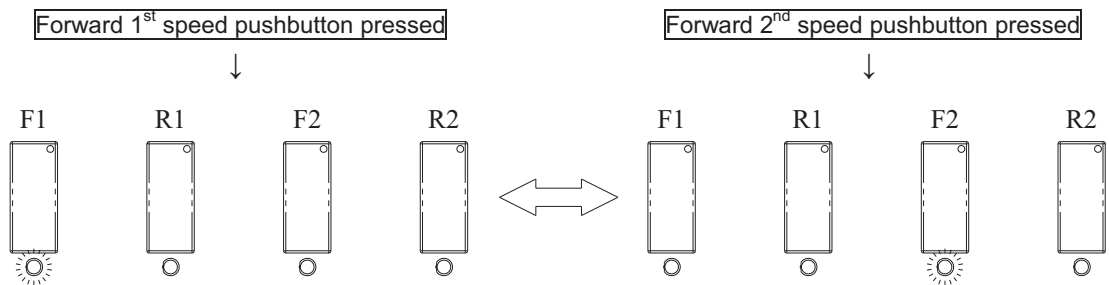

- 4 output relays configuration with Closed/Closed contact at 2<sup>nd</sup> speed**  
F1 (or R1) output relay closed at 1<sup>st</sup> speed and F1 + F2 (or R1 + R2) output relays closed at 2<sup>nd</sup> speed. Refer to section 4.2.3.1 on how to set to this function.

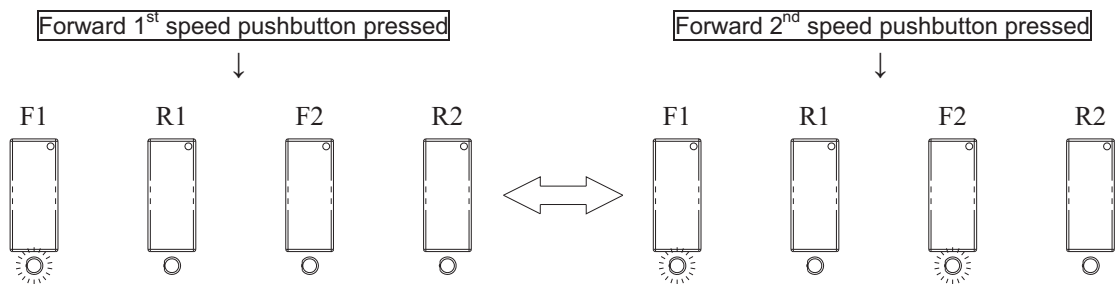

- 4 output relays configuration with Slow and Fast output relays (Type A)**  
Fwd (or Rev) + Slow output relays closed at 1<sup>st</sup> speed and Fwd (or Rev) + Fast output relays closed at 2<sup>nd</sup> speed. Refer to section 4.2.3.1 on how to set to this function.

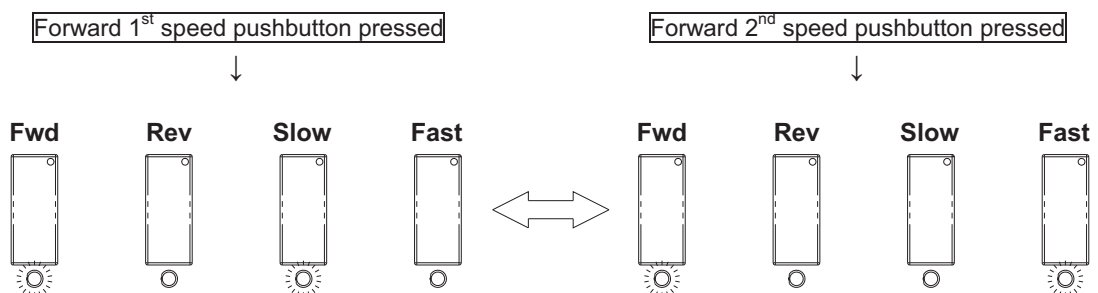

5. **4 output relays configuration with Slow and Fast output relays (Type B)**  
 Fwd + Slow (or Rev + Slow) output relays closed at 1<sup>st</sup> speed and Fwd + Slow + Fast (or Rev + Slow + Fast) output relays closed at 2<sup>nd</sup> speed. Refer to section 4.2.3.1 on how to set to this function.

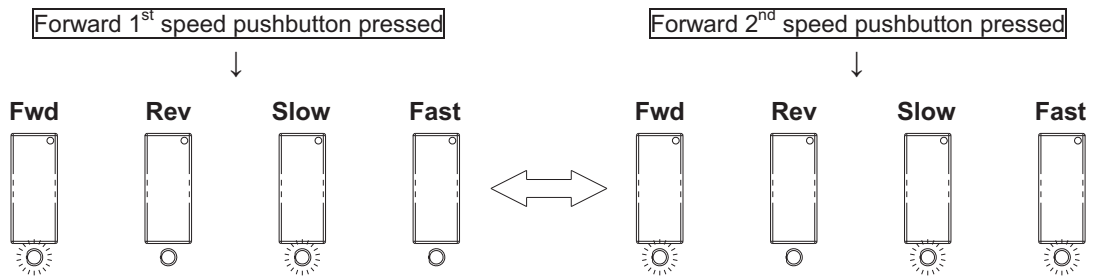

#### 4.2.2.3. START + AUX Function

After executing the START command at transmitter startup the same START position becomes an auxiliary function with momentary contact connected through K25 Function output relay. There are other types of auxiliary functions made available for K25, K26 and K30 Function output relays (refer to section 4.2.7). Please contact ARC representative if your application requires other types of auxiliary function connected to these Function output relays.

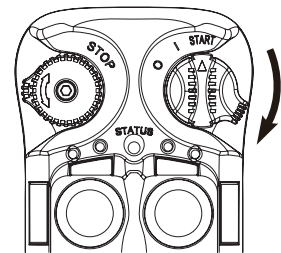

#### 4.2.2.4. ON/OFF Pushbutton Function

The user can set any of the two adjacent pushbuttons on the transmitter to behave like a mechanical ON & OFF rocker or toggle switch. ON output relay closes when ON pushbutton is pressed (OFF output relay opens) and OFF output relay closes when OFF pushbutton is pressed (ON output relay opens). Refer to section 4.2.3.1 on how to set to this function.

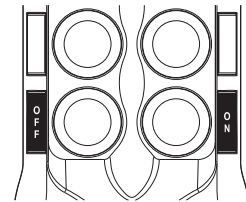

#### 4.2.2.5. Magnet ON/OFF Pushbutton Function

The user can set any of the two adjacent pushbuttons on the transmitter to control industrial magnet lift. Activate the magnet by pressing the Magnet ON pushbutton. Deactivate the magnet by first press and hold the Magnet ON pushbutton and then press the Magnet OFF pushbutton. Pressing the Magnet OFF pushbutton alone is unable to deactivate the magnet. Refer to section 4.2.3.1 on how to set to this function.

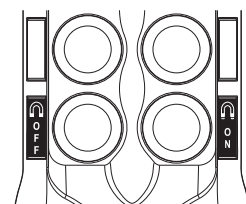

#### 4.2.2.6. Brake Function (Flex 8EX only)

When the transmitter pushbutton is released from 2<sup>nd</sup> speed up to 1<sup>st</sup> speed, both 1<sup>st</sup> and 2<sup>nd</sup> speed output relays will open for up to 1 second and then with 1<sup>st</sup> speed output relay closed thereafter. Refer to section 4.2.3.1 on how to set to this function.

#### 4.2.2.7. External Warning Function

The user can install an external warning device (rotating lights, horn, etc...) to the K26 Function output relay located inside the receiver. The user can choose which pushbutton pair (or pairs) triggers the external warning device when pressed. Refer to section 4.2.3.1 on how to set to this function.



### 4.2.2.8. Momentary Contact

When pushbutton is released the corresponding output relay will open or deactivate. This type of relay action usually applies to external applications such as horn and buzzer. Refer to section 4.2.3.2 on how to set to this function.

### 4.2.2.9. Toggled Contact

When pushbutton is released the corresponding output relay will maintained contact or closure until next time the user presses the same pushbutton again. This type of relay action usually applies to external application such as lights. Refer to section 4.2.3.2 on how to set to this function.

### 4.2.2.10. Pitch & Catch Function

This function allows two operators controlling from opposite ends of a crane or equipment. When set to "Pitch & Catch" make sure the 2<sup>nd</sup> transmitter is set to the next upper channel (channel X+1). For example, if the system is set to channel 01 then the newly added 2<sup>nd</sup> transmitter must be set to channel 02 with identical serial number. Furthermore, the Channel dipswitch position #7 and #8 on the decoder board must set to "10" for 2-channel scanning (scans channel 01 and 02). Refer to section 4.2.2.11 and 4.2.3.2 on how to set to this function. Pitch & Catch function must set to assigned channel scheme (refer to section 4.1.2 part B).

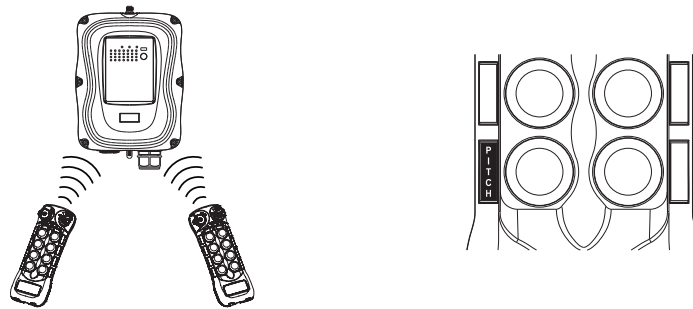

### 4.2.2.11. Receiver Channel Scanning Function

Receiver channel scanning function is applicable only when a preset channel is assigned to the system (refer to section 4.1.2 part B).

- (1) → "00" manufacture preset (channel X)\*
- (2) → "01" scans 2 channels (channel X and channel X+1)
- (3) → "10" scans 3 channels (channel X... channel X+2)
- (4) → "11" scans 4 channels (channel X... channel X+3)\*\*

\* Channel X → channel set on the Channel dipswitch.

\*\* Please contact ARC representative if your application requires scanning more than 4 channels.

**Example:** If the first 6 dipswitch positions are set to channel 01 (000001), when set to 2-channel scanning (type-2 above) the receiver will only scan channel 01 and 02.

## 4.2.3. Dipswitch Settings

### 4.2.3.1. Interlocked Pushbutton Pair

Interlocked means any pushbutton pair can not be pressed simultaneously as it will cancel each other out. Interlocked setting usually applies to electric motor's forward & reverse motion and On & Off switches. Each dipswitch on the decoder board corresponds to a pushbutton pair.

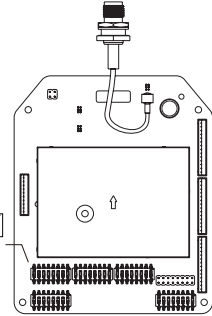
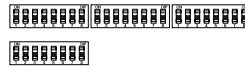

Dip Settings	Function Descriptions	# of Relays Used
00000000	Single speed only	2
00000010	4 output relays Closed/Closed relay action at 2 <sup>nd</sup> speed (separate 2 <sup>nd</sup> speed output relays)	4
00000100	3 output relays Closed/Closed relay action at 2 <sup>nd</sup> speed (shared 2 <sup>nd</sup> speed output relay)	3
00000110	4 output relays Opened/Closed relay action at 2 <sup>nd</sup> speed (separate 2 <sup>nd</sup> speed output relays)	4
00001000	Forward (or Reverse) + Fast output relays engaged at 2 <sup>nd</sup> speed	4
00001010	Forward (or Reverse) + Slow + Fast output relays engaged at 2 <sup>nd</sup> speed	4
00001100	On (right button) & Off (left button)	2
00010010	On + Start/Off + Start - For added safety, you must first rotate and hold the power switch key at START position and then press the On or Off pushbutton to activate the output relay.	2
00001110	Magnet Lift On & Off	2
00010100	FWD/REV toggled (latching)	2
00100000	Single speed + External warning*	2
00100010	4 output relays Closed/Closed relay action + External warning*	4
00100100	3 output relays Closed/Closed relay action + External warning*	3
00100110	4 output relays Opened/Closed relay action + External warning*	4
01000010	4 output relays Closed/Closed relay action + Brake	4
01000100	3 output relays Closed/Closed relay action + Brake	3
01000110	4 output relays Opened/Closed relay action + Brake	4

01100010	4 output relays Closed/Closed relay action + Brake + External warning*	4
01100100	3 output relays Closed/Closed relay action + Brake + External warning*	3
01100110	4 output relays Opened/Closed relay action + Brake + External warning*	4

\* External warning function requires installing an external warning device such as horn and lights to the K26 Function output relay.

#### 4.2.3.2. None-Interlocked Pushbutton Pair

Non-interlocked setting allows the pushbutton pair be pressed simultaneously. It usually applies to equipment's auxiliary functions such as lights, horn or buzzer. Each dipswitch on the decoder board corresponds to a pushbutton pair. Only the first 7 dipswitch positions are used (counting from left to right), the 8<sup>th</sup> dipswitch position (far right) is not used.

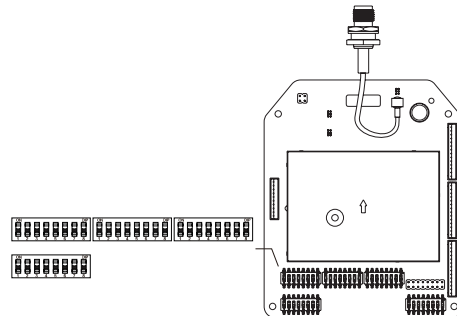
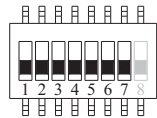

Function Code	Dip Position #1	Dip Position #2 ~ #4 (left button) & #5 ~ #7 (right button)	Function Description
A	1	000	Normal momentary contact
B	1	001	Toggled/latching contact (type A)
C	1	011	Toggled/latching contact (type B) <i>Output relay disconnects when STOP button is pressed or transmitter power off</i>
D	1	100	Normal + Start function <i>For added safety, must first rotate and hold the power switch key at the START position and then press the intended pushbutton to activate the output relay</i>
E	1	110	Pitch & Catch (type A)

<b>F</b>	1	101	Pitch & Catch (type B) <i>Receiver MAIN relays maintained closure during switchovers</i>
<b>G</b>	1	111	2 steps with Closed/Closed relay action

Example #1: Left button (set to function code A) / right button (set to function code B) → **1 000 001**

Example #2: Left button (set to function code C) / right button (set to function code D) → **1 011 100**

#### 4.2.4. Jumper Settings

Jumper setting applies to functions such as the standard or reversed logic A/B selector sequence, transmitter inline pushbutton configurations, firmware version, system testing and remote pairing methods.

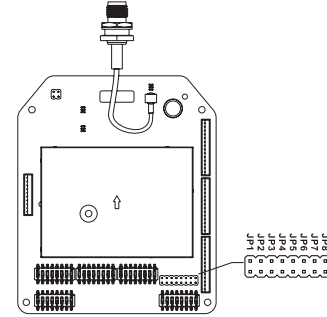

Jumper Settings		Function
JP3 (Opened)		<b>Standard A/B selector sequence</b> - Output relay A activated at A position, output relay B activated at B position, both relays activated at A+B position.
JP3 (Inserted)		<b>Reversed logic A/B selector sequence</b> - Output relay B activated at A position, output relay A activated at B position, both relays deactivated at A+B position.
JP4 (Opened)	JP5 (Opened)	Standard right/left pushbutton configuration
JP4 (Inserted)	JP5 (Opened)	Inline top/bottom pushbutton configuration for PB1 to PB8
JP4 (Opened)	JP5 (Inserted)	Inline top/bottom pushbutton configuration for PB1 to PB12
JP4 (Inserted)	JP5 (Inserted)	Inline top/bottom pushbutton configuration for PB1 to PB4
JP6 (Inserted)		System firmware version
JP7 (Inserted)		For system testing only (receiver MAIN relays disabled)
JP8 (Opened)		Receiver-to-transmitter remote pairing (pressing the Pairing button required)
JP8 (Inserted)		Receiver-to-transmitter remote pairing (pressing the Pairing button not required)

## 4.2.5. Voltage Settings

Prior to installation always check the voltage setting is correct for your application.

Position 1 → 110~120VAC

Position 2 → 220~240VAC or 48VAC\* or 24VAC\*\*

Position 3 → 380~400VAC or 110~120VAC\* or 42VAC\*\*

Position 4 → 410~460VAC or 220~240VAC\* or 48VAC\*\* or 9~36VDC\*\*\*

\* For system equipped with 48/110~120/220~240VAC power supply.

\*\* For system equipped with 24/42/48VAC power supply.

\*\*\* For system equipped with 9~36VDC power supply.

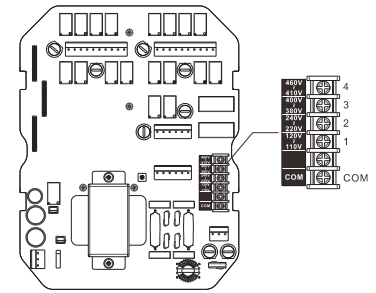

FUSE #	110~120VAC	220~240VAC	380~400VAC	410~460VAC	24VAC	42 & 48VAC	9~36VDC
F3 ~ F10	5.0A	5.0A	5.0A	5.0A	5.0A	5.0A	5.0A
F1 ~ F2	1.0A	1.0A	1.0A	0.5A	3.0A	2.0A	2.0A

## 4.2.6. Indicator Light and Buzzer Installation

The miniature indicator light and buzzer can be easily fitted onto the receiver enclosure. The indicator light or the buzzer works simultaneously with the receiver MAIN relays (manufacture preset). When receiver MAIN relays are activated the indicator light or the buzzer is also activated, or vice versa. Make sure the indicator light or the buzzer is connected to the K30 Function output relay CN11 port located on the AC line filter/relay board inside the receiver. Please contact ARC representative if you would like the indicator light or the buzzer work differently than described above.

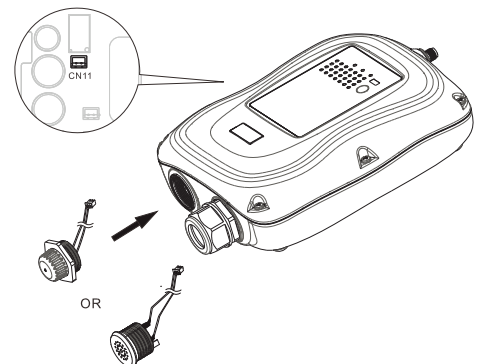

## 4.2.7. Other Function Output Relays Settings

Listed below are other types of functions that can be outputted through the three Function output relays (K25, K26 and K30) via the infrared IR programmer unit. Please contact ARC representative for more details.

**LV** → Function relay closes when receiver voltage is low.

**ID** → Function relay works simultaneously with all motion commands.

**NORMAL** → START function + AUX with normal momentary output.

**TOGGLE** → START function + AUX with toggled/latching output.

**TOG&E** → START function + AUX with toggled/latching output. The relay opens when STOP button is pressed down and transmitter power off.

**S/P** → Function relay closes when START command is executed and opens only when transmitter power is turned off.

**EXT** → Function relay works simultaneously with the receiver MAIN relays.

**TDM A+B** → Function relay closes when selector switch is rotated to the A+B position and opens when rotate to A or B positions (tandem monitoring output).

**HORN** → Function relay closes for up to 3 seconds when START command is executed at transmitter power on and then becomes a normal momentary output thereafter.

**G SENSOR** → Function relay closes when Zero-G sensor is triggered (receiver MAIN relays deactivated) and opens when receiver MAIN relays are reactivated.

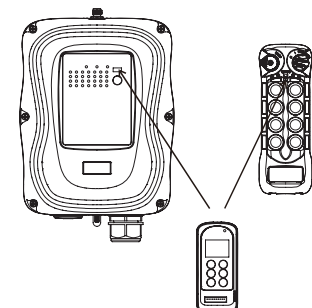



# 5. Receiver Installation

## 5.1. Output Relay Contact Diagrams

### Flex 8ES (single speed model)

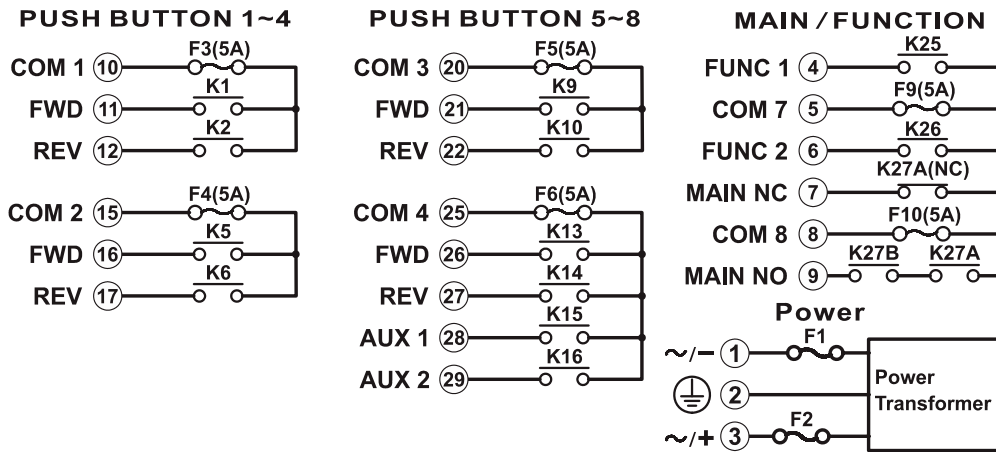

### Flex 8EX (dual speed model)

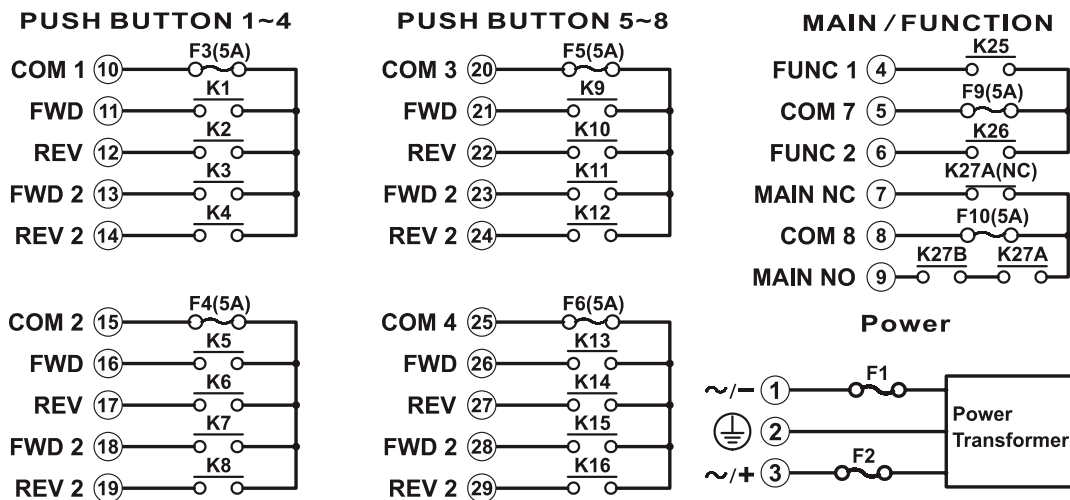

\* For 9~36VDC power supply, wire #1 corresponds to the negative charge (-) and wire #3 corresponds to the positive charge (+), wire #2 is GROUND.

\* If PB7 (or PB8) is set to A/B pushbutton select or A/B rotary switch select function (AB models), connect output A to K13 relay (or K14) and output B to K15 relay (or K16). Refer to section 4.1.8.2 on how to set to this function.

## 5.2. Pre-installation Precautions

1. Make sure the transmitter and receiver are with identical serial number and channel.
2. Make sure the receiver is not set to the same channel as any other systems in use in the surrounding area.
3. Make sure the crane or equipment is working properly prior to installation.
4. Make sure the power source to the receiver is set correctly.
5. Switch off the main power source to the crane or equipment prior to installation.

## 5.3. Step-By-Step Installation

**Mounting Bracket Type 1**

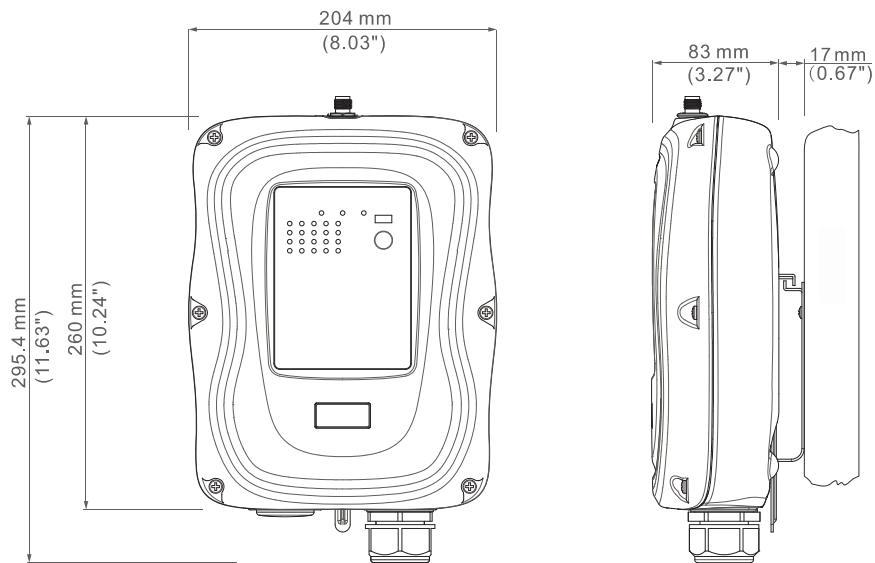

**Mounting Bracket Type 2**

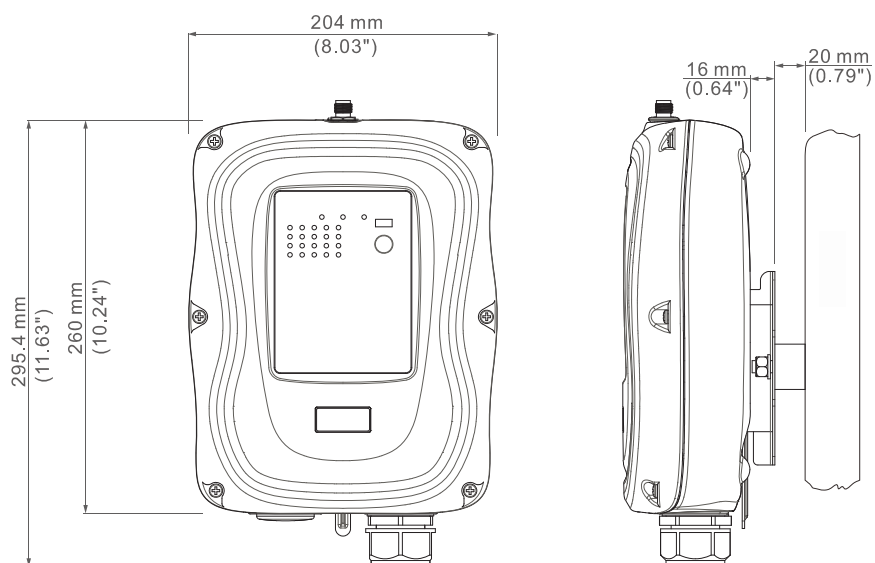



1. For best reception the location of the receiver should be visible to the operator at all time.
2. The location selected should not be exposed to high levels of electric noise. Mounting the receiver next to an unshielded variable frequency drive may cause radio interference. Always locate the receiver as far away from variable frequency drive and electric motor as possible.
3. Ensure the selected location has adequate space to accommodate the receiver. If an external antenna is used, to avoid the possibility of antenna damage always locate the receiver where the antenna is free from any obstacles.
4. When installing an external antenna make sure the MCX jack located on the decoder board inside the receiver is connected and jumper set to "EXT" position.

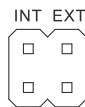
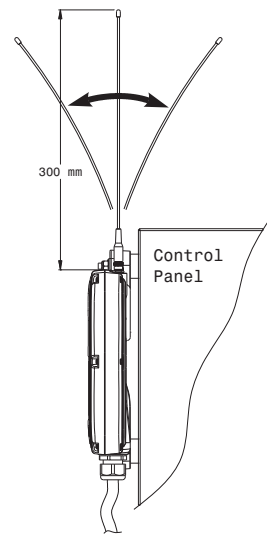

5. For better reception, make sure the receiver is in an upright position.
6. Drill four holes for mounting bracket type 1 and two holes for mounting bracket type 2 on the control panel, wall or location where the receiver is to be installed.
7. Make sure the screws, bolts or shock absorbers are tightened after installation (not provided with the system).

#### Mounting Bracket Type 1

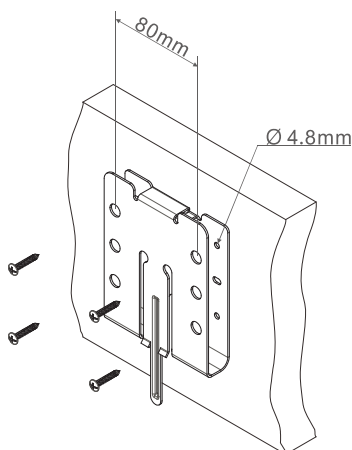

#### Mounting Bracket Type 2

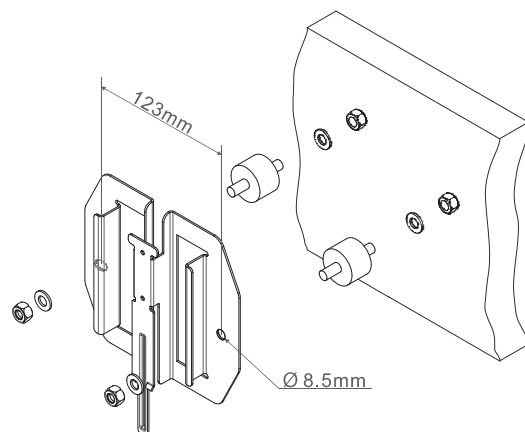

8. Slide down the receiver along the guided track to secure the receiver to the mounting bracket.
9. Remove the receiver by pressing down the bracket release and pull the receiver upward until it clears the guided track.

# Install

## Mounting Bracket Type 1

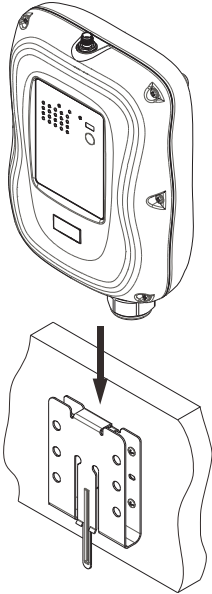

## Mounting Bracket Type 2

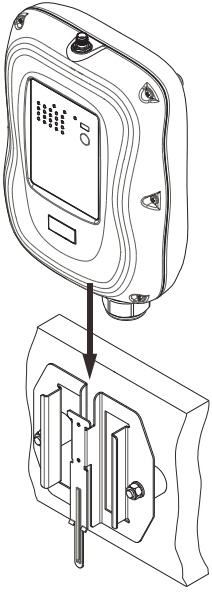

# Remove

## Mounting Bracket Type 1

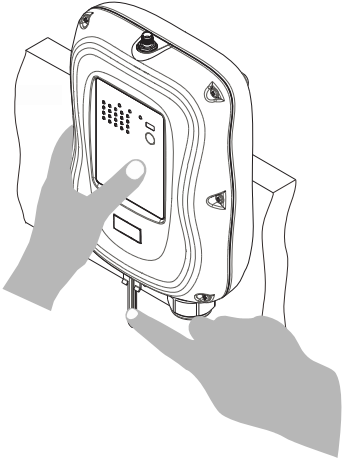

## Mounting Bracket Type 2

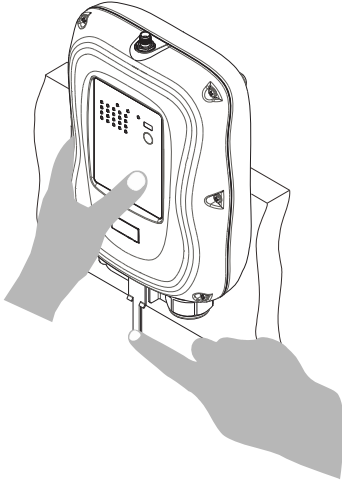

# 6. Operating Procedures

## 6.1. General Operation

- a. Reset the STOP button located on the top left hand corner of the transmitter by rotating it clockwise or counter clockwise, the button will pop up. Turn on the transmitter power by inserting the power switch key and rotate to ON ( I ) position.

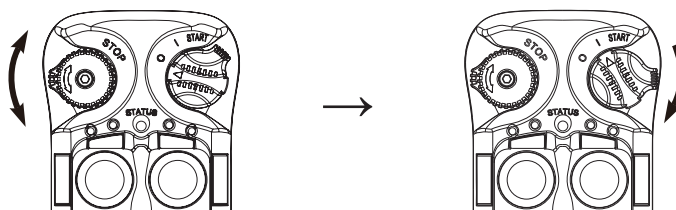

- b. After turning on the transmitter power, check the Status LED on the transmitter for any sign of system irregularities (refer to section 6.10.1 Transmitter Status Indications). If the transmitter is in good working order the Status LED will display constant green for up to 2 seconds at power on (no faults detected).
- c. Rotate the power switch key further to the START position and hold it there for up to 2 seconds (Status LED constant green). When the receiver MAIN relays are activated the Status LED will change from constant green to constant orange (system on). The power switch key will retract back to the ON ( I ) position when let go. The same START position becomes an auxiliary function thereafter (refer to section 4.2.2.3 START + AUX Function). Pressing any pushbutton prior to executing the START command at system startup will result in no signals transmitted (Status LED blinks orange).
- d. Now press any pushbutton on the transmitter to begin operation. During transmitter inactivity (pushbuttons not pressed), the transmitter will automatically switch to standby mode, with an orange blink on the Status LED every 4-second interval. Always turn off the transmitter power when not in use to save battery power.

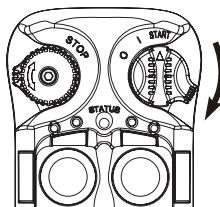

- e. In case of an emergency, press down the STOP button to disconnect the receiver MAIN relays (Status LED blinks 3 reds and then shuts off). To resume operation, rotate the STOP button clockwise or counter clockwise, the button will pop up. Then execute the START command to reconnect the receiver MAIN relays. For safety, executing the START command is strictly required every time when the transmitter is turned on or after every STOP button reset.

- f. After 5 or 30 minutes of inactivity (pushbutton not pressed) the receiver MAIN relays are temporarily disconnected (refer to section 4.1.5 Inactivity Timer Settings). The Status LED blinks 3 reds and then shuts off. Press any pushbutton or execute the START command to resume operation (refer to section 4.1.4 Start Function Settings).
- g. Turn off the transmitter power by rotating the power switch key counter clockwise to Off ( 0 ) position; it will disconnect the transmitter power and the receiver MAIN relays altogether. Turn it further counter clockwise to release the key.

## 6.2. Master/Master Tandem Operation (Tandem models)

- a. To gain control of one or both receivers, first rotate the selector switch to either A, B or A+B position and then execute the START command to activate the receiver MAIN relays inside receiver A, receiver B, or both receivers (depending on the selector switch position). In order to gain control of a receiver, the PITCH pushbutton on the other transmitter must be pressed prior to your takeover. For example, in order for transmitter-A to gain control of receiver-B, transmitter-B must first release its control of receiver-B by first rotate the selector switch to B position and then press the PITCH pushbutton for up to 2.0 seconds. This action releases transmitter-B control of receiver-B. Transmitter-A is then able to take control of receiver-B by first rotate the selector switch to B position and then execute the START command. Make sure the START command is executed 2.0 seconds after transmitter-B presses the PITCH pushbutton (refer to diagram below).

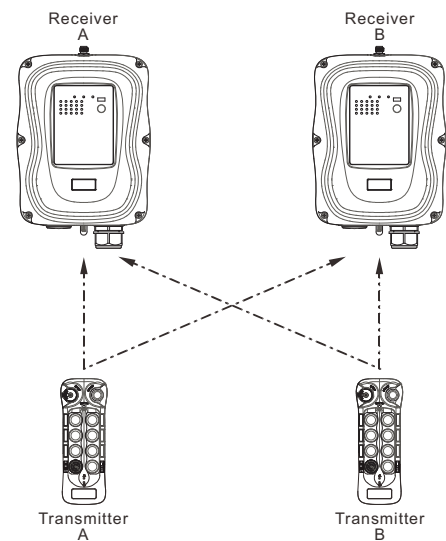

### Master Transmitter-A Takeover Procedure

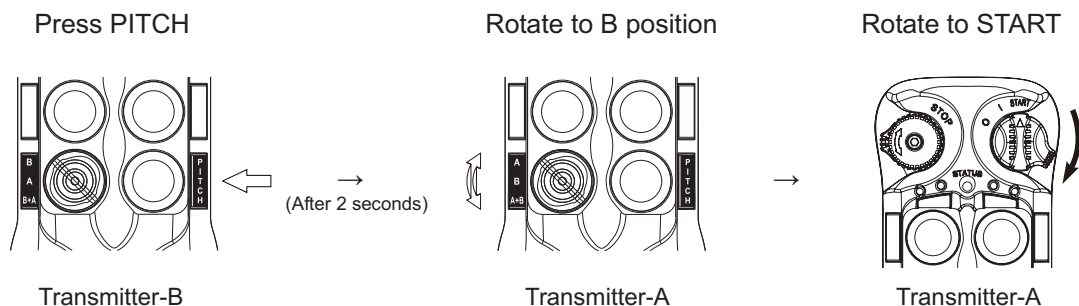

## Master Transmitter-B Takeover Procedure

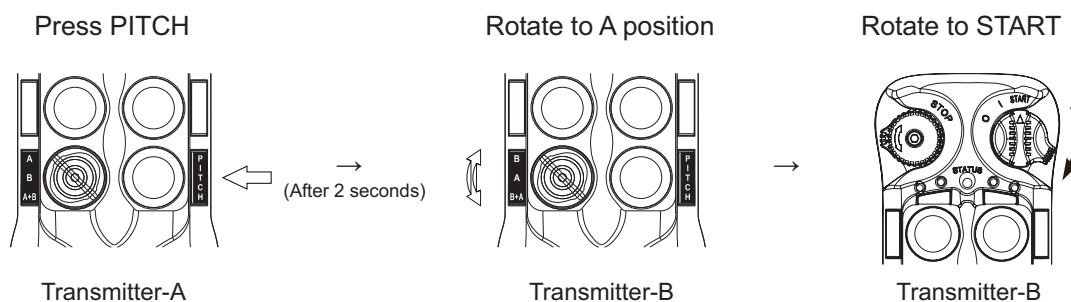

- Once the transmitter is locked on to both receivers, rotate the selector switch to either A, B, or A+B position for independent or simultaneous operation.
- At beginning of each shift prior to turning on the transmitter power, always check if the selector switch is correctly positioned for the intended receiver or receivers.
- For safety, there is a 2-second grace period followed after executing the PITCH command. What this means is that after PITCH pushbutton is pressed, executing the START command on the other transmitter within this 2-second grace period is ineffective. In order to gain control of the other receiver you must first wait for up to 2 seconds after the other transmitter presses the PITCH pushbutton and then for you to execute the START command thereafter.

## 6.3. Master/Slave Tandem Operation (Tandem models)

- To gain control of one or both receivers, first rotate the selector switch to either A, B or A+B position and then execute the START command to activate the receiver MAIN relays inside receiver A, receiver B, or both receivers (depending on the selector switch position). In order to gain control of a receiver, the PITCH pushbutton on the other transmitter must be pressed prior to your takeover. For example, in order for Master transmitter to gain control of the Slave receiver (receiver-B), Slave transmitter must first release control of its receiver (receiver-B) by pressing the PITCH pushbutton for up to 2.0 seconds. This action releases Slave transmitter control of its receiver (receiver-B). Master transmitter is then able to take control of the Slave receiver (receiver-B) by first rotate the selector switch to B position and then execute the START command. Make sure the START command is executed 2.0 seconds after Slave transmitter presses the PITCH pushbutton (refer to diagram below).

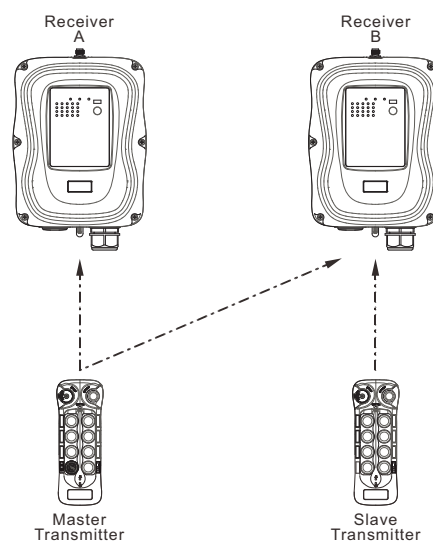

## Master Transmitter Takeover Procedure

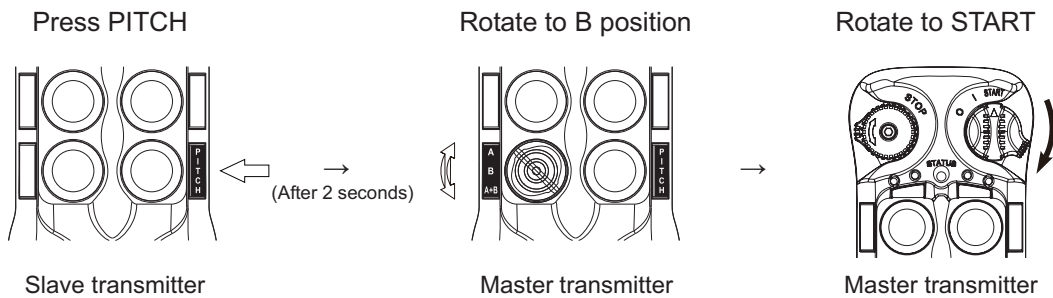

## Slave Transmitter Takeover Procedure

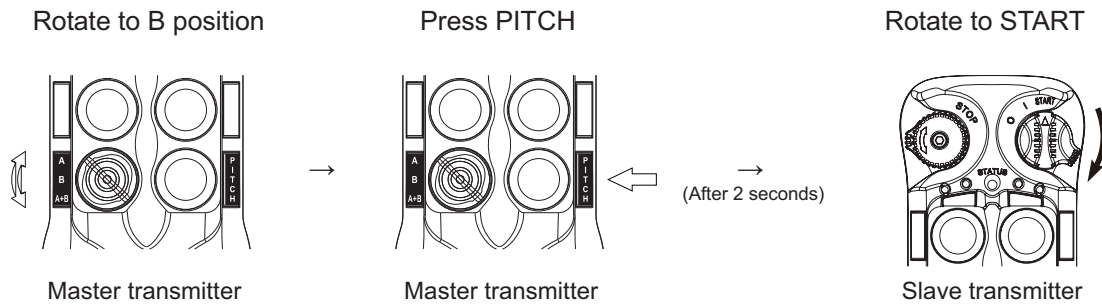

- Once the transmitter is locked on to both receivers, rotate the selector switch to either A, B, or A+B position for independent or simultaneous operation.
- At beginning of each shift prior to turning on the transmitter power, always check if the selector switch is correctly positioned for the intended receiver or receivers.
- For safety, there is a 2-second grace period followed after executing the PITCH command. What this means is that when PITCH pushbutton is pressed, executing the START command on the other transmitter within this 2-second grace period is ineffective. In order to gain control of the other receiver you must first wait for up to 2 seconds after the other transmitter presses the PITCH pushbutton and then for you to execute the START command thereafter.

## 6.4. A/B Pushbutton Select Operation

Press the “A/B” pushbutton repeatedly toggles between output relay A, B and A+B respectively. There are 4 different types of Select A/B sequence available (refer to section 4.1.8.2).

**Standard** – Output relay A activated at A position, output relay B activated at B position, both output relays activated at A+B position.

**Reversed logic** - Output relay A activated at B position, output relay B activated at A position, both output relays deactivated at A+B position. Refer to section 4.2.4 JP3 jumper settings.

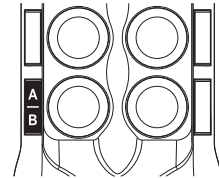

## 6.5. A/B Rotary Select Operation (AB models)

**Standard** - Rotate to A position activates output relay A, rotate to B position activates output relay B, rotate to A+B position activates both output relays.

**Reversed logic** - Rotate to A position activates output relay B, rotate to B position activates output relay A, rotate to A+B position deactivates both output relays. Refer to section 4.2.4 JP3 jumper setting.

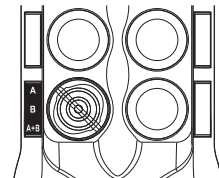

## 6.6. Pitch & Catch Operation

Press the “PITCH” pushbutton for up to 2 seconds to release control of the receiver. After 2-second grace period, rotate the power switch key to START position for up to 2 seconds to gain control of the receiver. The 2<sup>nd</sup> operator is unable to take control of the receiver unless the 1<sup>st</sup> operator presses the “PITCH” pushbutton. Refer to section 4.2.2.10 and section 4.2.3.2 on how to set to this function.

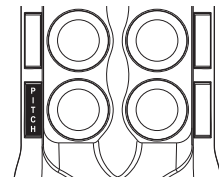

## 6.7. Transmitter Access Card (TAC) Operation

After turning on the transmitter power, place the TAC directly over the RFID marking located on the backside of the transmitter. A 2-second green on the Status LED represents access card accepted. Status LED with red blinks represents invalid access card. Then rotate the power switch key to the START position for up to 2 seconds to begin operation. TAC is not required after every transmitter inactivity restart, only during initial transmitter power on.

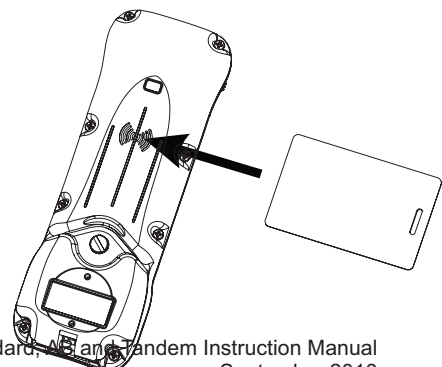

## 6.8. Changing Batteries

Changing transmitter batteries (“AA” alkaline battery x 2) by unscrewing the battery cover located on the backside of the transmitter. During battery installation make sure the batteries are installed correctly, with “+” to “+” charge and “-” to “-” charge. Also make sure the screw is tightened after battery installation to avoid water, moisture, dirt, grease, and other liquid penetration.

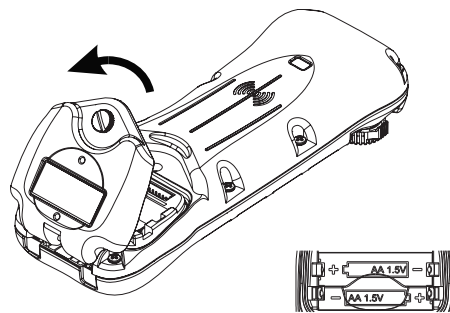

## 6.9. Battery Charging

The transmitter is designed to accept any off-the-shelf Ni-MH rechargeable batteries. When charging both transmitter and individual batteries at the same time the priority always goes to the transmitter charging. The individual battery charging begins only after the transmitter charging is completed. Depending on the battery capacity the average charging time is approximately 2.5 hours from completely drained to fully charged. Constant red on the LED represents charging in progress, constant green represents batteries fully charged, and LED off represents no batteries detected. Please do not use any rechargeable lithium ion batteries as it will damage both the transmitter and the charging station.

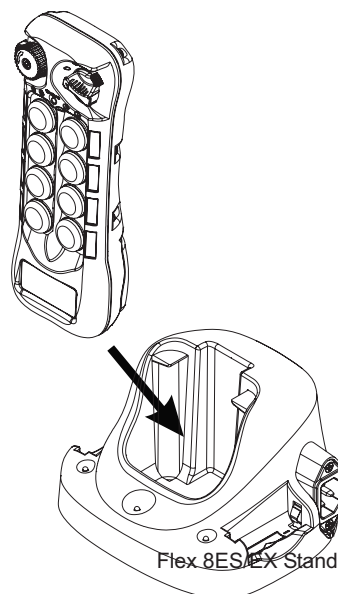



## 6.10. System Status Light Indications

### 6.10.1 Transmitter Status Indications

Type	Display Type	Indication
1	Constant red	Voltage below 1.8V at initial power on or during operation
2	3 red blinks and then off	Voltage below 1.75V during operation (receiver MAIN relays shut off)
3	1 red blink followed by a 2-second pause	Voltage below 1.85V during operation (change batteries suggested)
4A	2 red blinks followed by a 2-second pause	Defective or jammed pushbutton detected at initial power on
4B	No light displayed	When defective pushbutton condition occurs (2 red blinks, type 4A above), find out which pushbutton is defective by pressing all of them one at a time. If the pushbutton is in good working order when pressed, the Status LED is off. If the Status LED maintained 2 red blinks then the pushbutton is defective.
5	4 red blinks followed by a 2-second pause	Transmitter is unable to lock onto the assigned channel
6	Constant green for up to 2 seconds	Transmitter power on with no faults detected
7	Blinking green	Transmission in progress
8	Blinking orange	Pressing any pushbutton prior to executing the START command at power on
9	2 orange blinks followed by a 2-second pause	Receiver MAIN relays jammed or defective
10	3 orange blinks followed by a 2-second pause	Decoding processors defective

11	3 slow red blinks	STOP button pressed down
----	-------------------	--------------------------

### 6.10.1. Receiver Status Indications

Type	Display Type (Green & Red)	Indication
1	Fast green blinks	Decoding in process
2	Slow green blinks	Decoding on standby
3	2 red blinks	Receiver MAIN relays jammed or defective
4	3 red blinks	Decoding processors defective
5	4 red blinks	Receiving RF board defective
6	Fast red blinks	Incorrect transmitter serial number
7	Constant red	Receiver low voltage
8	No light displayed	Decoding processors defective
9	3 slow red blinks followed by slow green blinks	STOP button pressed down

### 6.10.2. Receiver Power Indications

Type	Display Type (Red)	Indication
1	On	Power to receiver
2	Off	No power to receiver

### 6.10.3. Receiver COM Indications

Type	Display Type (Red)	Indication
------	--------------------	------------

1	On	Power to relay Board
2	Off	No power to relay board

## 7. General Specifications

Frequency Range	:	433MHz ~ 440MHz
Number of Channels	:	141 channels
Channel Spacing	:	50 KHz
Modulation	:	Digital Frequency Modulation based on Manchester Code, 20bit address, 32bit CRC and Hamming Code.
Encoder & Decoder	:	Microprocessor-controlled
Transmitting Range	:	> 100 Meters (300 feet)
Hamming Distance	:	> 6
Frequency Control	:	Synthesized PLL
Receiver Type	:	Frequency Auto Scanning
Receiver Sensitivity	:	-116dBm
Spurious Emission	:	-50dB
Antenna Impedance	:	50 ohms
Responding Time	:	40mS (average)
Transmitting Power	:	1.0mW
Enclosure Type	:	NEMA4
Enclosure Rating	:	IP66
Output Contact Rating	:	250V @ 8 Amps
Transmitter Operating Voltage	:	3.0VDC
Receiver Power Consumption	:	22VA (max)
Available Receiver Voltages	:	9~36VDC 24VAC 42VAC 48VAC 110~120VAC 220~240VAC 380~400VAC 410~460VAC
Operating Temperature	:	-25°C ~ 50°C / -13°F ~ 167°F
Transmitter Dimension	:	198mm (L) x 70mm (W) x 44mm (H)
Receiver Dimension	:	260mm (L) x 204mm (W) x 83mm (H)
Transmitter Weight	:	292g / 10.3oz (include batteries)
Receiver Weight	:	2.75kg / 6.1lb (include output cable)