

DS-561SQ-S7A1E,
DS-562SQ-S6A1E

Computer/ 微型計算機

ADVANTECH

Enabling an Intelligent Planet

Copyright

The documentation and the software included with this product are copyrighted 2013 by Advantech Co., Ltd. All rights are reserved. Advantech Co., Ltd. reserves the right to make improvements in the products described in this manual at any time without notice.

No part of this manual may be reproduced, copied, translated or transmitted in any form or by any means without the prior written permission of Advantech Co., Ltd. Information provided in this manual is intended to be accurate and reliable. However, Advantech Co., Ltd. assumes no responsibility for its use, nor for any infringements of the rights of third parties, which may result from its use.

Acknowledgements

Award is a trademark of Award Software International, Inc.

IBM, PC/AT, PS/2 and VGA are trademarks of International Business Machines Corporation.

Intel® and ATOM® are trademarks of Intel Corporation. RTL is a trademark of Realtek

Semi-Conductor Co., Ltd. ESS is a trademark of ESS Technology, Inc. UMC is a trademark of United Microelectronics Corporation. SMI is a trademark of Silicon Motion, Inc. Creative is a trademark of Creative Technology LTD. CHRONTEL is a trademark of Chrontel Inc. All other product names or trademarks are properties of their respective owners.

For more information about this and other Advantech products, please visit our web-site at:

<http://www.advantech.com/> For technical support and service, please visit our support website at: <http://support.advantech.com.tw/support/>

Product Warranty (18 months)

Advantech warrants to you, the original purchaser, that each of its products will be free from defects in materials and workmanship for two years from the date of purchase.

This warranty does not apply to any products which have been repaired or altered by persons other than repair personnel authorized by Advantech, or which have been subject to misuse, abuse, accident or improper installation. Advantech assumes no liability under the terms of this warranty as a consequence of such events.

Because of Advantech's high quality-control standards and rigorous testing, most of our customers never need to use our repair service. If an Advantech product is defective, it will be repaired or replaced at no charge during the warranty period. For outof-warranty repairs, you will be billed according to the cost of replacement materials, service time and freight. Please consult your dealer for more details.

If you think you have a defective product, follow these steps:

- 1 Collect all the information about the problem encountered. (For example, CPU speed, Advantech products used, other hardware and software used, etc.) Note anything abnormal and list any onscreen messages you get when the problem occurs.
- 2 Call your dealer and describe the problem. Please have your manual, product, and any helpful information readily available.
- 3 If your product is diagnosed as defective, obtain an RMA (return merchandise authorization) number from your dealer. This allows us to process your return more quickly.
- 4 Carefully pack the defective product, a fully-completed Repair and Replacement Order Card and a photocopy of the proof of purchase date (such as your sales receipt) in a shippable container. A product returned without proof of the purchase date is not eligible for warranty service.
- 5 Write the RMA number visibly on the outside of the package and ship it prepaid to your dealer.

Declaration of Conformity

FCC Class B

Note: This equipment has been tested and found to comply with the limits for a Class B digital device, pursuant to part 15 of the FCC Rules. These limits are designed to provide reasonable protection against harmful interference when the equipment is operated in a commercial environment. This equipment generates, uses, and can radiate radio frequency energy and, if not installed and used in accordance with the instruction manual, may cause harmful interference to radio communications. Operation of this equipment in a residential area is likely to cause harmful interference in which case the user will be required to correct the interference at his own expense.

Technical Support and Assistance

1. Visit the Advantech website at www.advantech.com/support where you can find the latest information about the product.

2. Contact your distributor, sales representative, or Advantech's customer service center for technical support if you need additional assistance. Please have the following information ready before you call:

Product name and serial number

Description of your peripheral attachments

Description of your software (operating system, version, application software, etc.)

A complete description of the problem

The exact wording of any error messages

Warnings, Cautions and Notes



Warning! Warnings indicate conditions, which if not observed, can cause personal injury!



Caution! Cautions are included to help you avoid damaging hardware or losing data. e.g. There is a danger of a new battery exploding if it is incorrectly installed. Do not attempt to recharge, force open, or heat the battery. Replace the battery only with the same or equivalent type recommended by the manufacturer. Discard used batteries according to the manufacturer's instructions.

Note!

Notes provide optional additional information.



低功率電波輻射性電機管理辦法

第十二條 經型式認證合格之低功率射頻電機，非經許可，公司、商號或使用者均不得擅自變更頻率、加大功率或變更原設計之特性及功能。

第十四條 低功率射頻電機之使用不得影響飛航安全及干擾合法通信；經發現有干擾現象時，應改善至無干擾時方得繼續使用。前項合法通信，指依電信法規定作業之無線電通信。低功率射頻電機須忍受合法通信或工業、科學及醫療用電波輻射性電機設備之干擾。

Safety Instructions

1. Read these safety instructions carefully.
2. Keep this User Manual for later reference.
3. Disconnect this equipment from any AC outlet before cleaning. Use a damp cloth. Do not use liquid or spray detergents for cleaning.
4. For plug-in equipment, the power outlet socket must be located near the equipment and must be easily accessible.
5. Keep this equipment away from humidity.
6. Put this equipment on a reliable surface during installation. Dropping it or letting it fall may cause damage.
7. The openings on the enclosure are for air convection. Protect the equipment from overheating. **DO NOT COVER THE OPENINGS.**
8. Make sure the voltage of the power source is correct before connecting the equipment to the power outlet.
9. Position the power cord so that people cannot step on it. Do not place anything over the power cord.
10. All cautions and warnings on the equipment should be noted.
11. If the equipment is not used for a long time, disconnect it from the power source to avoid damage by transient overvoltage.
12. Never pour any liquid into an opening. This may cause fire or electrical shock.
13. Never open the equipment. For safety reasons, the equipment should be opened only by qualified service personnel.
14. If one of the following situations arises, get the equipment checked by service personnel:
 - The power cord or plug is damaged
 - Liquid has penetrated the equipment.
 - The equipment has been exposed to moisture.
 - The equipment does not work well, or you cannot get it to work according to the user's manual.
 - The equipment has been dropped and damaged.
 - The equipment has obvious signs of breakage.
15. **DO NOT LEAVE THIS EQUIPMENT IN AN ENVIRONMENT WHERE THE STORAGE TEMPERATURE MAY GO BELOW -20° C (-4° F) OR ABOVE 60° C (140° F). THIS COULD DAMAGE THE EQUIPMENT. THE EQUIPMENT SHOULD BE IN A CONTROLLED ENVIRONMENT.**
16. **CAUTION: DANGER OF EXPLOSION IF BATTERY IS INCORRECTLY REPLACED. REPLACE ONLY WITH THE SAME OR EQUIVALENT TYPE RECOMMENDED BY THE MANUFACTURER, DISCARD USED BATTERIES ACCORDING TO THE MANUFACTURER'S INSTRUCTIONS.**
The sound pressure level at the operator's position according to IEC 704-1:1982 is no more than 70 dB (A). **RESTRICTED ACCESS AREA:** The equipment should only be installed in a Restricted Access Area.

DISCLAIMER: This set of instructions is given according to IEC 704-1. Advantech disclaims all responsibility for the accuracy of any statements contained herein.

Packing List

Before installation, please ensure the following items have been shipped:

- 1 x DS-561 Unit
- 1 x English User Manual
- 1x Accessory box

Chapter 1 General Introduction

This chapter gives background information on DS-561 series.

1.1 Introduction

The DS-561 is powered by 3rd generation Intel Core i7 processor-based platform with Dsub 15pin VGA x 1 and Display Port x 1. DS-561 media player is the only one ultra slim device (166x 177x 19mm) in the worldwide and build Windows 8 Professional of OS Image that enables digital signage manufacturers to deploy systems faster and development and implementation. The player-screen communication interface supports digital audio/video signals via display port, for picture-perfect content reproduction. DS-561 also supports 1x Giga LAN, 1x COM ports, 2x USB3.0 and 2x USB2.0 giving a great selection for data communication in display applications. The entire design makes digital signage applications more intelligent and connected.

1.2 Product Features

1.2.1 General

- 3rd generation Intel® Core™ i7 processor-based platform
- Supports DP, USB2.0 and USB3.0 via JAE 80-pin connector
- Ultra Slim Features, easy to install

1.2.2 Display

Support up to 1920 x 1080 video playback performance (subject to the video media format and playback software)

1.2.3 Power Consumption

- Typical: 17 W
- Max.: 26 W

1.3 Hardware Specifications

- **CPU:** Intel 3rd generation Intel Core i7-3517UE 1.7 GHz
- **System Chipset:** Intel QM77 chipset
- **Graphic chipset:** Integrated graphics built in Processor
- **BIOS:** AMI 64 Mbit Flash BIOS via SPI Interface
- **System Memory:** 1 x DDR3 204-pin SODIMM sockets, supports up to 8GB per SO-DIMM
- **HDD:** Supports 1 x 2.5" SATA HDD (max 7mm height)
- **I/O Interface**

- 1 x VGA
- 1 x Display Port
- 2 x USB 3.0 compliant ports
- 2 x USB 2.0 compliant ports
- 1 audio phone jack for Line-out
- 1 x COM (RS-232)
- 1 x MiniPCle (Internal)
- **Ethernet Chipset:** 1 x Intel 82579LM
 - Speed: 100/1000 Mbps
 - Interface: 1 x RJ-45 jacks with LED
 - Standard: MACSec (802.1AE), 9k Jumbo Frames, and 2 Tx/Rx queues/ 802.3az (EEE - Energy Efficient Ethernet)
- **Resolution:** DP up to 1920 x 1080

1.4 Mechanical Specifications

1.4.1 Dimensions

166x 177x 19mm

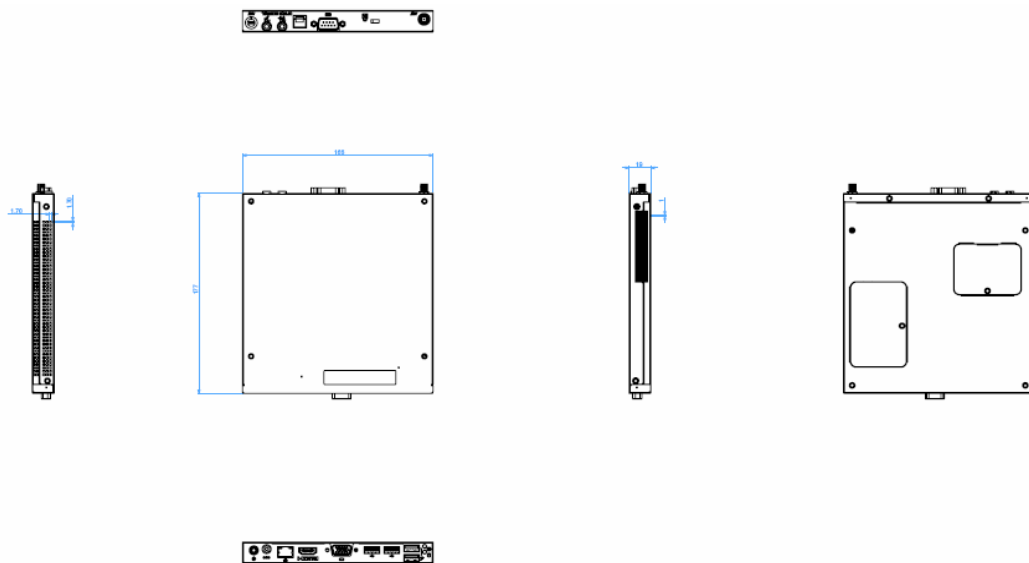

Figure. 1 DS-561 Mechanical Dimension (Unit: mm)

1.4.2 Weight

1.0 kg (2.2 lb.)

1.5.2. Installatiion with brackets

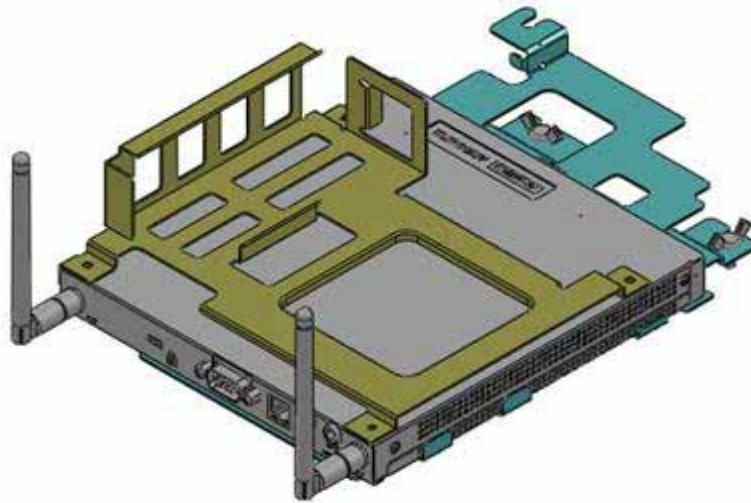

Figure. 6 System with Brackets (top view)

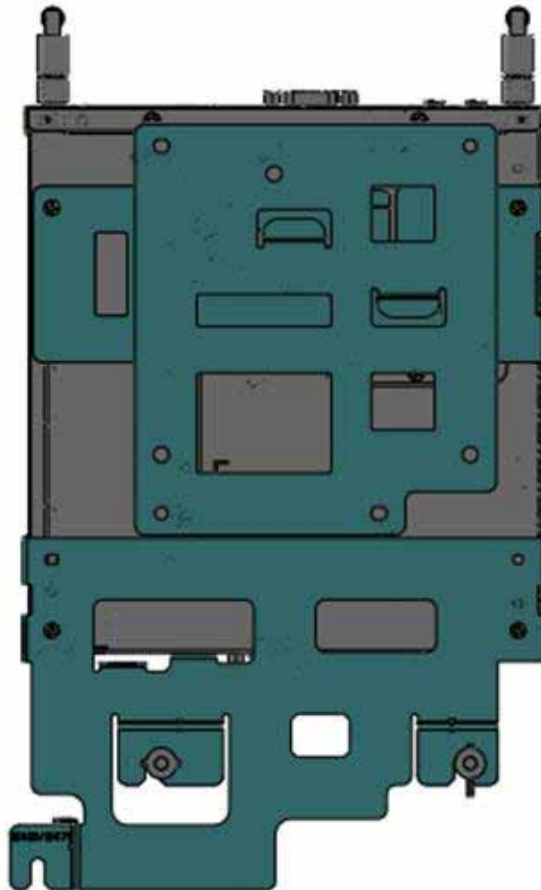
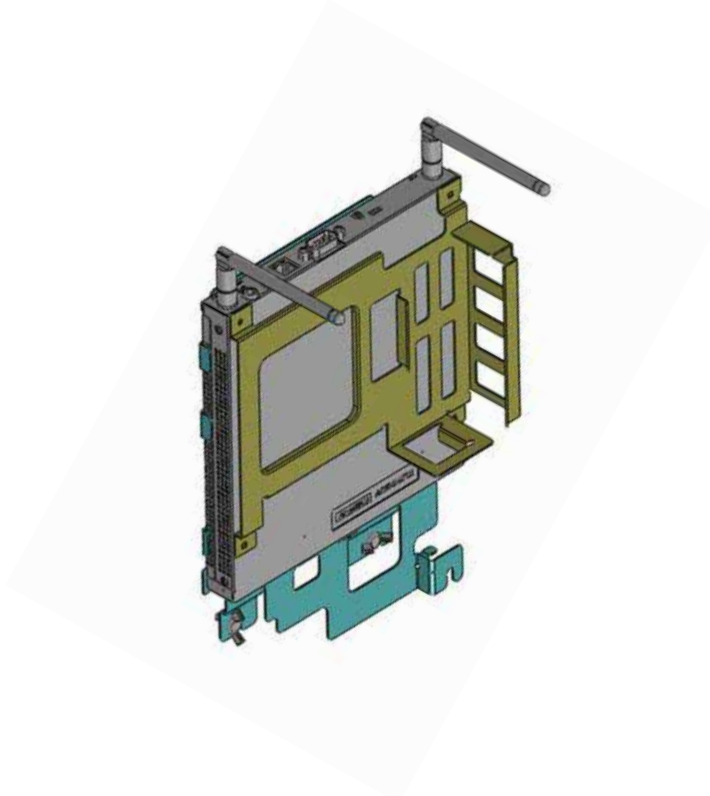

Figure. 7 System with brackets (bottom view)

****Note!** This pair of wallmount bracket is designed for side of chassis and bottom side. Reverse installation is not permitted.

1.5.3. Direction of Systems with bracket

(1) Direction method 1: Upright



(2) Direction method 2: Flatways

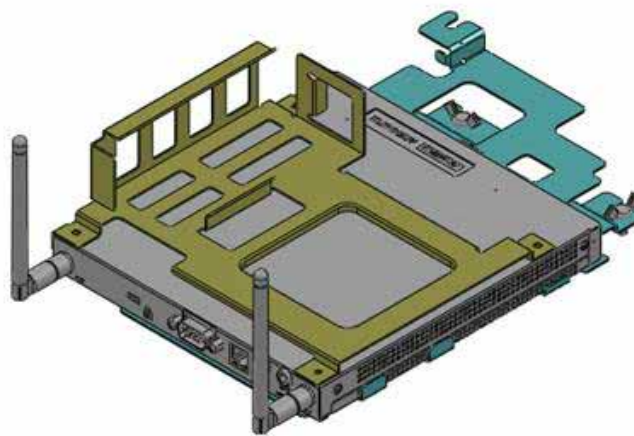

1.6 Power Requirements

1.6.1 System Power

19V DC-in

Model name	Output rated	Tma (degree C)
FSP065-RAB	19VDC, 3.42A	40I (+-5%)
FSP090-DMBB1	19VDC, 4.74A	40I (+-5%)
SPU63-105	19VDC, 3.31A	40I (+-5%)
ADP_65JH ABCD	19VDC, 3.42A	40I (+-5%)

****CAUTION:** Provided with each unit. "This product is intended to be supplied by an UL certified power

supply, output rated 19Vdc, 3.31A minimum, Tma=40 degree C." or equivalent statement provided in operating manual, if power unit is not provided.

1.6.2 RTC Battery

Panasonic 3V/200mAH BR2032L

****CAUTION: RISK OF EXPLOSION IF BATTERY IS REPLACED BY AN INCORRECT TYPE.
DISPOSE OF USED BATTERIES ACCORDING TO THE INSTRUCTIONS**

1.7 Environmental Specifications

1.7.1 Operating Temperature

0° C - 40° C (32~122° F)

1.7.2 Relative Humidity

95% @ 40° C (non-condensing)

1.7.3 Storage Temperature

40; 60 (-4~140° F)

1.7.4 Vibration Loading During Operation

5-500Hz, PSD 0.0005G²/Hz , 0.5 Grms, 3 axes, 1 hr/per axis

1.7.5 Safety

UL, TUV, CB, C-Tick, RCM, BSMI, CE LVD, NOM, EAC, S Mark, BSMI, CCC

1.7.6 EMC

CE, FCC Class B, VCCI, BSMI, C-Tick

1.7.7 RF

FCC, R&TTE, TELEC, NCC, FCC ID, A-Tick

Chapter 2 Hardware Installation

This chapter introduces external I/O and the installation of DS-561 Hardware.

2.1 DS-561 I/O Connectors

2.1.1 Front I/O

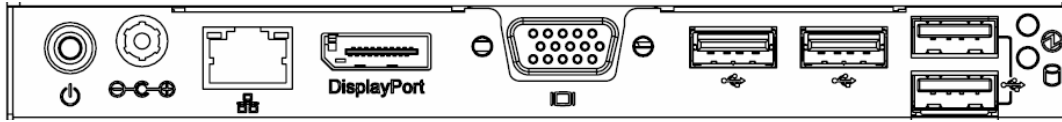

2.1.2 Rear I/O

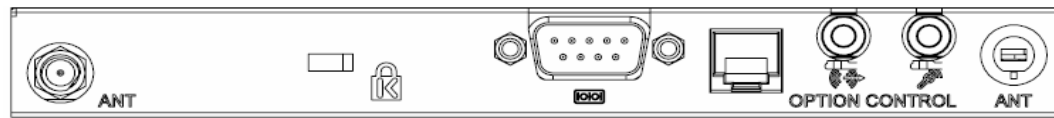

2.2 DS-561 External I/O Connectors

2.2.1 Power ON/OFF Button

DS-561 has a power ON/OFF button on the front side. Push this button to turn the system ON and OFF. It also supports a 5 second delay soft power off.



Figure. 8 Power ON/OFF Button

2.2.2 COM Connector

DS-561 provides one D-sub 9-pin connectors serial communication interface port. The ports support RS-232 mode communications.

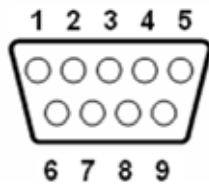

Figure. 9 COM Connector

Table. 1 COM Connector Pin Assignments

Pin	Signal Name
1	DCD
2	RxD
3	TxD
4	DTR
5	GND
6	DSR
7	RTS
8	CTS
9	RI

2.2.3 USB 1~4 Connectors

DS-561 provides four USB interface connectors, which gives complete Plug & Play and hot swapping capability for up to 127 external devices. The USB interface is compliant with USB UHCI, Rev. 3.0. and Rev. 2.0. The USB interface supports Plug and Play, which enables you to connect or disconnect a device without turning off the system.

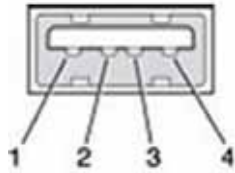

Figure. 10 USB 1~4 Connectors

Table. 2 USB 1~4 Port Pin Assignments

Pin	Signal Name
1	VCC
2	USB Data-
3	USB Data+
4	GND

2.2.4 Ethernet Connector (LAN)

DS-561 provides one RJ-45 LAN interface connector, fully compliant with IEEE802.3u 10/100/1000 Base-T CSMA/CD standards. The Ethernet port provides a standard RJ-45 jack connector with LED indicators to show its Active/Link status and speed status.

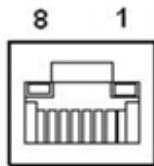

Figure. 11 Ethernet Connector

Table. 3 LAN Connector Pin Assignments

Pin	Signal Name
1	MDI0+
2	MDI0-
3	MDI1+
4	MDI1-
5	GND
6	GND
7	MDI2+
8	MDI2-
9	MDI3+
10	MDI3-
11	VCC
12	ACT
13	+V3.3 & Link1000#
14	+V3.3 & Link100#

2.2.5 Audio Connector

Line in/ Out: Stereo speakers, earphone or front surround speakers can be connected to the line -in/ line- out jack.

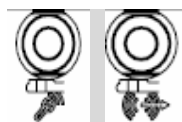

Figure. 12 Line-in/ Line-out

2.2.6 Power Switch (Optional Contrl): RJ11

RJ-11 only uses for Power switch between device and panel, not for telecommunicate function.

****CAUTION: EXCEPT POWER SWITCH FUNCTION, CAN CAUSE ANY DEVICE BURED UP, FIRE, AND DANGEROUS RESULTS.**

2.2.7 DisplayPort

DS-561 not only uses DP to achieve higher resolutions by low pin but also allows data packets to be extensible, meaning additional features can be added over time without significant changes to the physical interface itself. DisplayPort can be used to transmit audio and video simultaneously, but each one is optional and can be transmitted without the other.

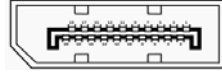

Figure. 13 External connector (source-side) on PCB

Table. 4 DisplayPort Pin out

Pin	Signal Name
1	ML_Lane 0 (p)
2	GND
3	ML_Lane 0 (n)
4	ML_Lane 1 (p)
5	GND
6	ML_Lane 1 (n)
7	ML_Lane 2 (p)
8	GND
9	ML_Lane 2 (n)
10	ML_Lane 3 (p)
11	GND
12	ML_Lane 3 (n)
13	CONFIG1
14	CONFIG2
15	AUX CH (p)
16	GND
17	AUX CH (n)
18	Hot Plug
19	Return
20	DP_PWR

2.3 Hardware Installation

2.3.1 HDD Installation

- (1) To assembly a HDD module, secure HDD to HDD bracket with 2 screws.
- (2) Install a HDD module into DS-561, then secure it with a screw.

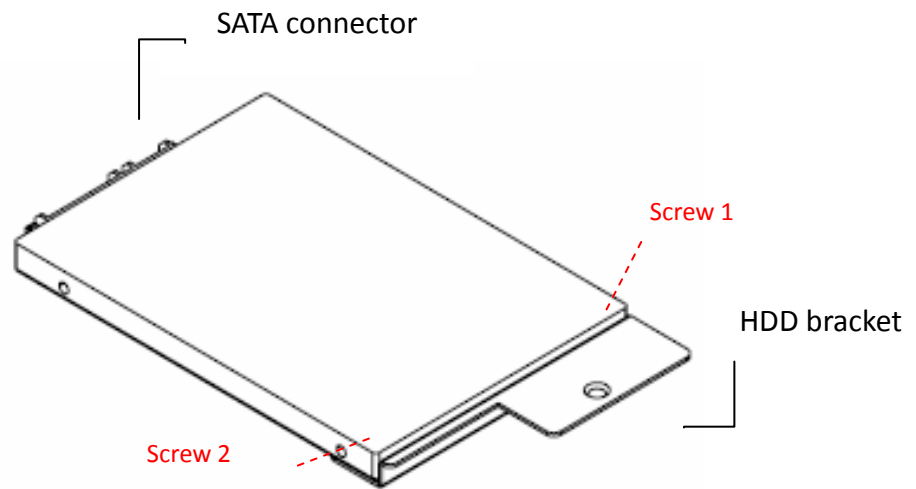

Figure. 14 HDD Installation

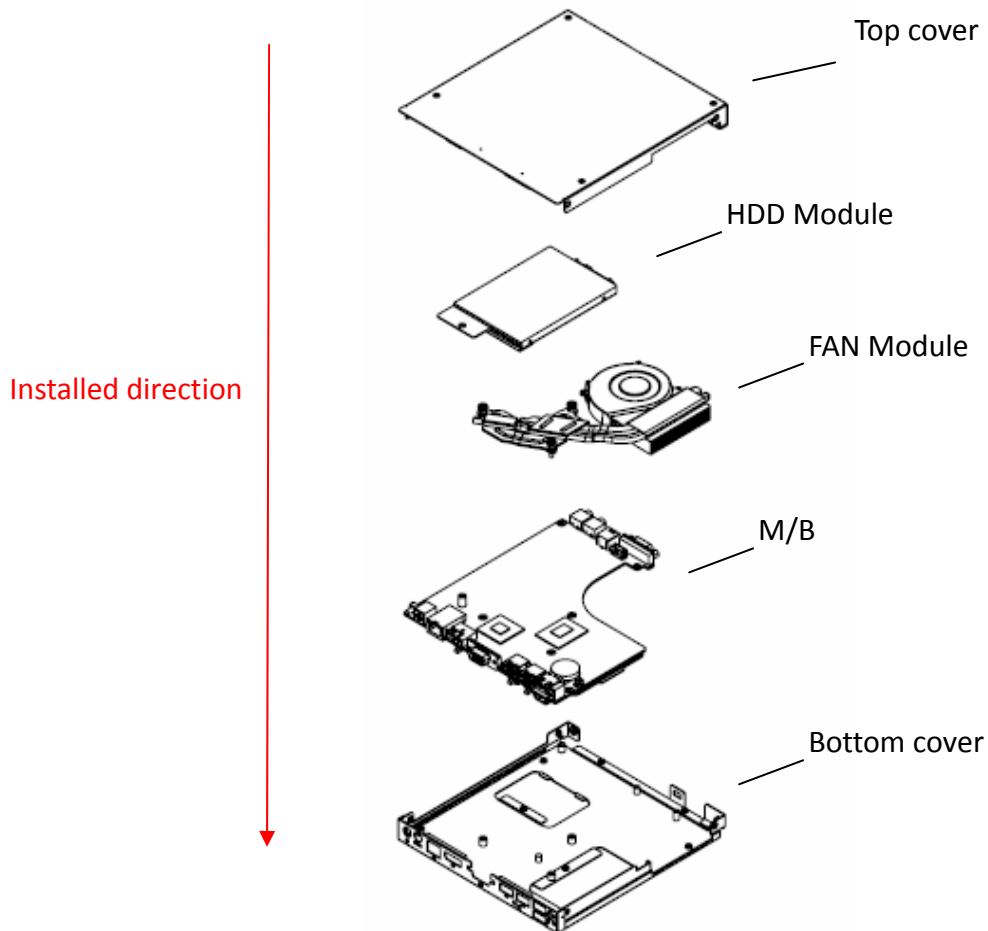

Figure. 15 System Installation

2.3.2 Memory Installation

- (1) Be easy to install/ remove memory on bottom cover.
- (2) Remove memory cover and replace memory inside.
- (3) Install the memory cover, then secure with screw.

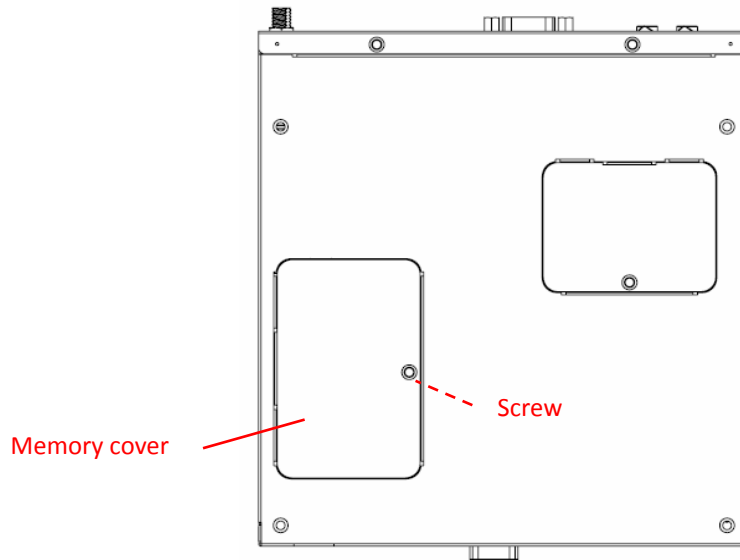

Figure. 16 Memory Installation

2.3.3 WiFi Module Installation

- (1) Be easy to remove/ install on bottom cover like memory installation.
- (2) Remove WiFi module cover first and replace WiFi module inside.
- (3) Install the WiFi module cover, then secure with screw.

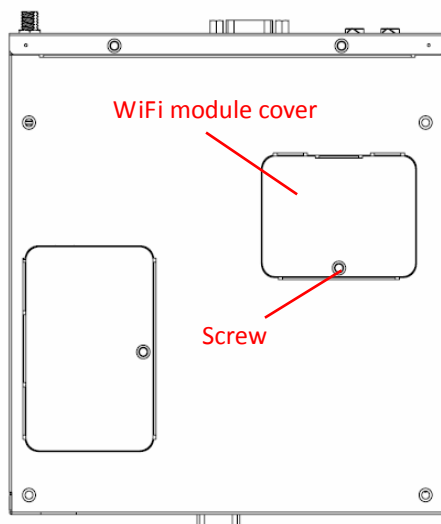

Figure. 17 System with WiFi module Installation

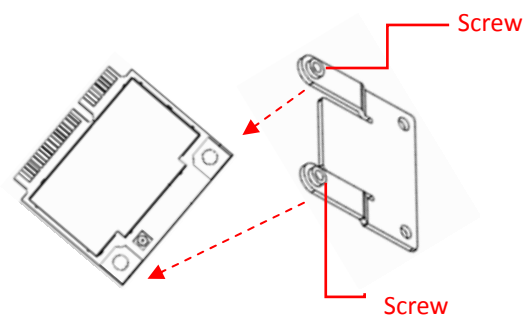

Figure. 18 WiFi module installation

Chapter 3 BIOS Settings

This chapter introduces how to set BIOS configuration data.

3.1 BIOS Introduction

AMIBIOS has been integrated into many motherboards for over two decades. With the AMIBIOS Setup program, you can modify BIOS settings and control various system features. This chapter describes the basic navigation of the DS-561 series BIOS setup screens.

AMIBIOS's ROM has a built-in setup program that allows users to modify the basic system configuration. This information is stored in battery-backed CMOS so it retains the setup information when the power is turned off.

3.2 Main Setup

When you first enter the BIOS Setup Utility, you will enter the Main setup screen. You can always return to the Main setup screen by selecting the Main tab.

The Main BIOS setup screen has two main frames. The left frame displays all the options that can be configured. Options in blue can be configured, and grayed-out options cannot be configured instead. The right frame displays the key legend.

The key legend in the top is an area reserved for a text message. When an option is selected in the left frame, it is highlighted in white. Often a text message will accompany it.

3.2.1 System Time/ System Date

Use this option to change the system time and date. Highlight System Time or System Date using the <Arrow> keys. Enter new values through the keyboard. Press the <Tab> key or the <Arrow> keys to move between fields. The date must be entered in MM/DD/YY format. The time must be entered in HH:MM:SS format.



Figure. 19 Main Setup Screen

3.2.2 Advanced BIOS Features Setup

Select the Advanced tab from the DS-561 setup screen to enter the Advanced BIOS Setup screen. You can select any of the items in the left frame of the screen, such as CPU configuration, to go to the sub menu for that item. You can display an Advanced BIOS Setup option by highlighting it using the <Arrow> keys. All Advanced BIOS Setup options are described in this section. The Advanced BIOS Setup screens are shown below. The sub menus are described on the following pages.

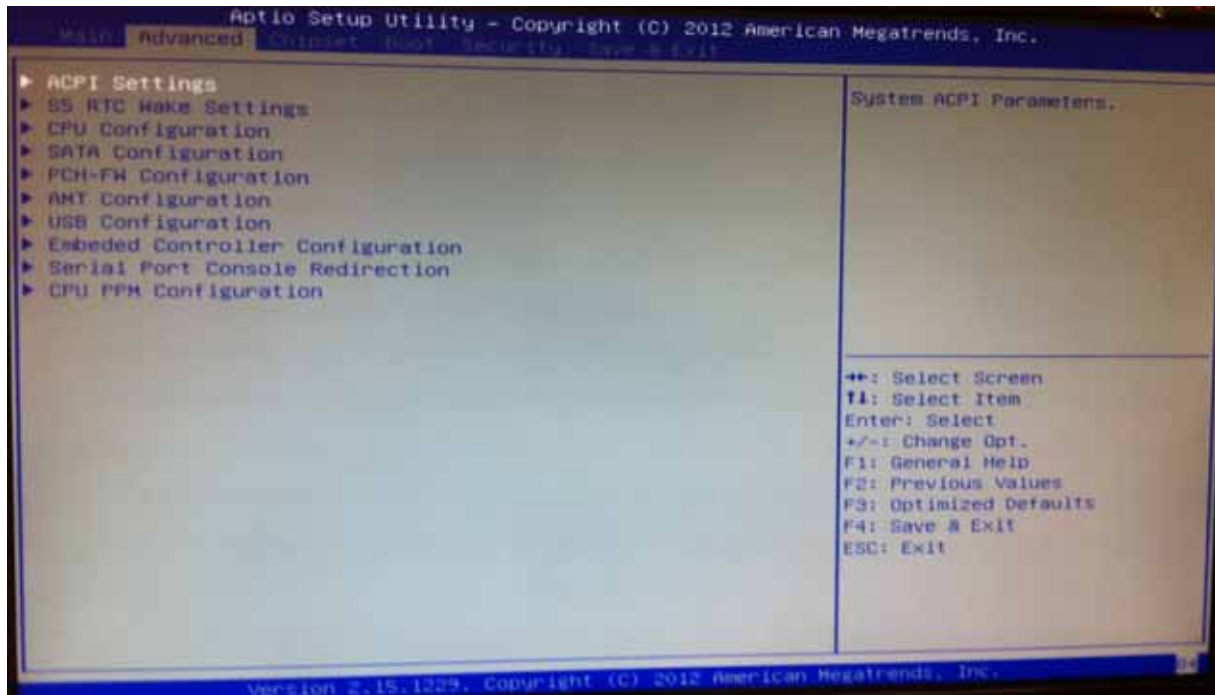

Figure. 20 Advanced BIOS Features Setup Screen

- **ACPI Settings:** This section allows you to control hardware monitoring and power management
- **CPU Configuration:**
 - **Hyper-threading:** Enabled for Windows XP and Linux (OS optimized for Hyper-Threading Technology) and Disabled for other OS (OS not optimized for Hyper-Threading Technology). When disabled, only one thread per enabled-core is enabled.
 - **Active Processor Cores:** Number of cores to be enabled in each processor package.
 - **Limit CPUID Maximum:** Disabled for Windows XP.
- **Execute Disable Bit:**

It can prevent certain classes of malicious buffer overflow attacks when combined with a supporting OS (Windows Server 2003 Sp1, Windows XP SP2, SuSE Linux 9.2 RedHat Enterprise 3 Update 3.).

 - **Intel Virtualization Technology:** When enabled, a VMM can utilize the additional hardware capabilities provided by Vander pool Technology.
 - **Hardware Prefetcher:** To turn on/off the Mid Level Cache (L2) streamer prefetcher.
 - **Adjacent Cache Line Prefetch:** To turn on/off prefetching of adjacent cache lines

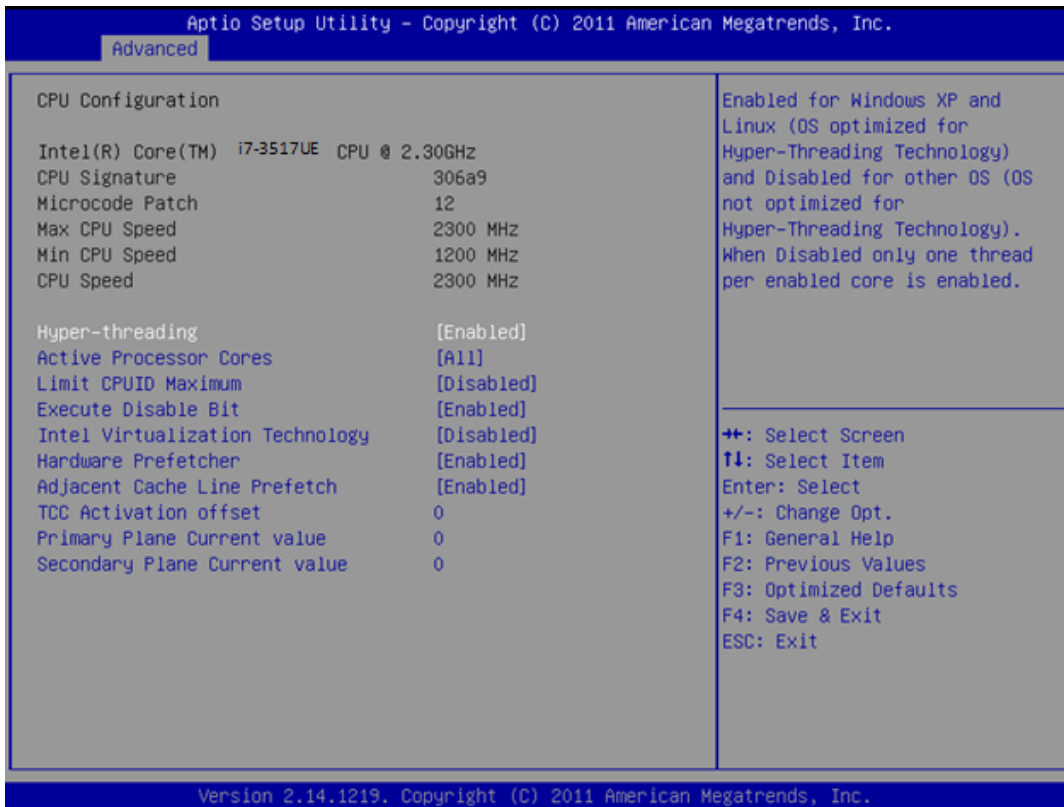

Figure. 21 CPU Setting page

- **SATA Configuration:**

This section allows you to set up SATA devices configuration.

- **SATA Controller(s):** Enable or disable SATA Device.
- **SATA Mode Selection:** Determines how SATA controller(s) operate. The choice: IDE, AHCI, RAID

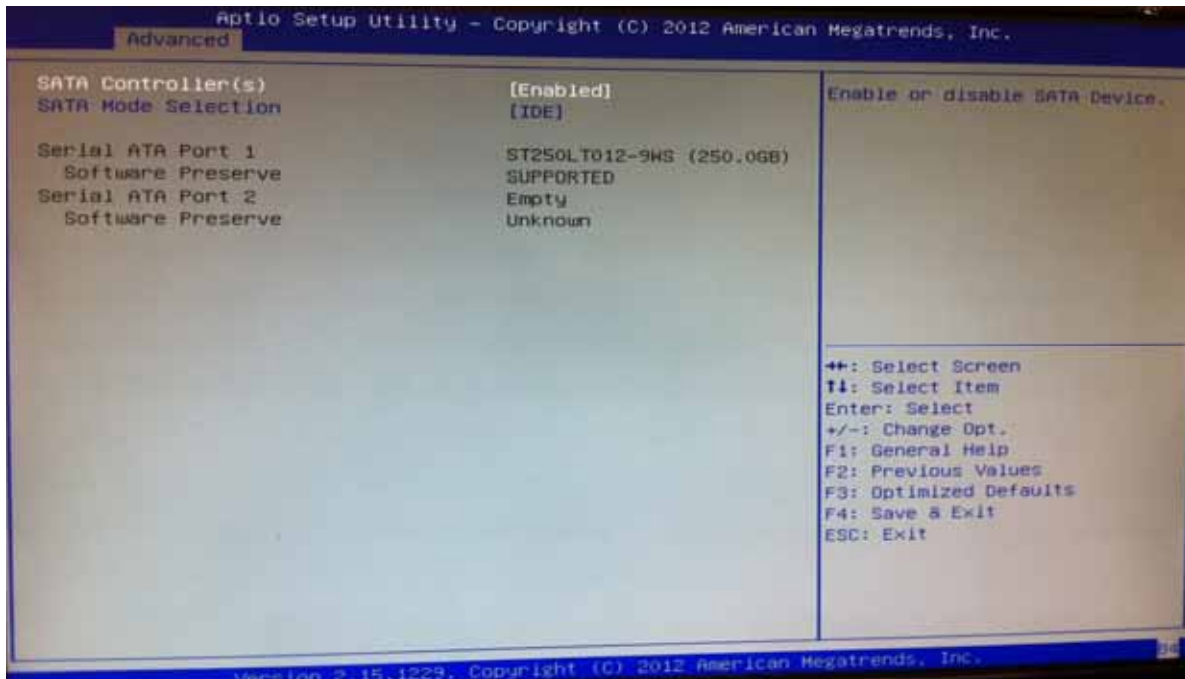

Figure. 22 SATA Setting page

- **PCH-FW Configuration:** Configuration Management Engine Technology Parameters.

- **AMT Configuration:** Configuration Active Management Technology parameters.
 - **Intel AMT:** Enable/Disable Intel(R) Active Management Technology BIOS Extension.
 - Note: iAMT H/W is always enabled. This option just controls the BIOS extension. If enabled, this requires additional firmware in the SPI device.
 - **BIOS Hotkey Pressed:** OEMFLag Bit 1: Enable/Disable BIOS hotkey press.
 - **MEBx Selection Screen:** OEMFLag Bit 2: Enable/Disable MEBx selection screen.
 - **Hide Un-Configure ME Confirmation:** OEMFLag Bit 6: Hide Un-Configure ME without password Confirmation Prompt.
 - **MEBx Debug Message Output:** OEMFLag Bit 14: Enable MEBx debug message Output.
 - **Un-Configure ME:** OEMFLag Bit 15: Un-Configure ME without password.
 - **Amt Wait Timer:** Set timer to wait before sending ASF_GET_BOOT_OPTIONS.
 - **ASF:** Enable/Disable Alert Specification Format
 - **Activate Remote Assistance Process:** Trigger CIRA boot.
 - **USB Configure:** Enable/Disable USB Configure function.
 - **PET Progress:** User can Enable/Disable PET Events progress to receive PET events or not.
 - **WatchDog:** Enable/Disable WatchDog Timer.

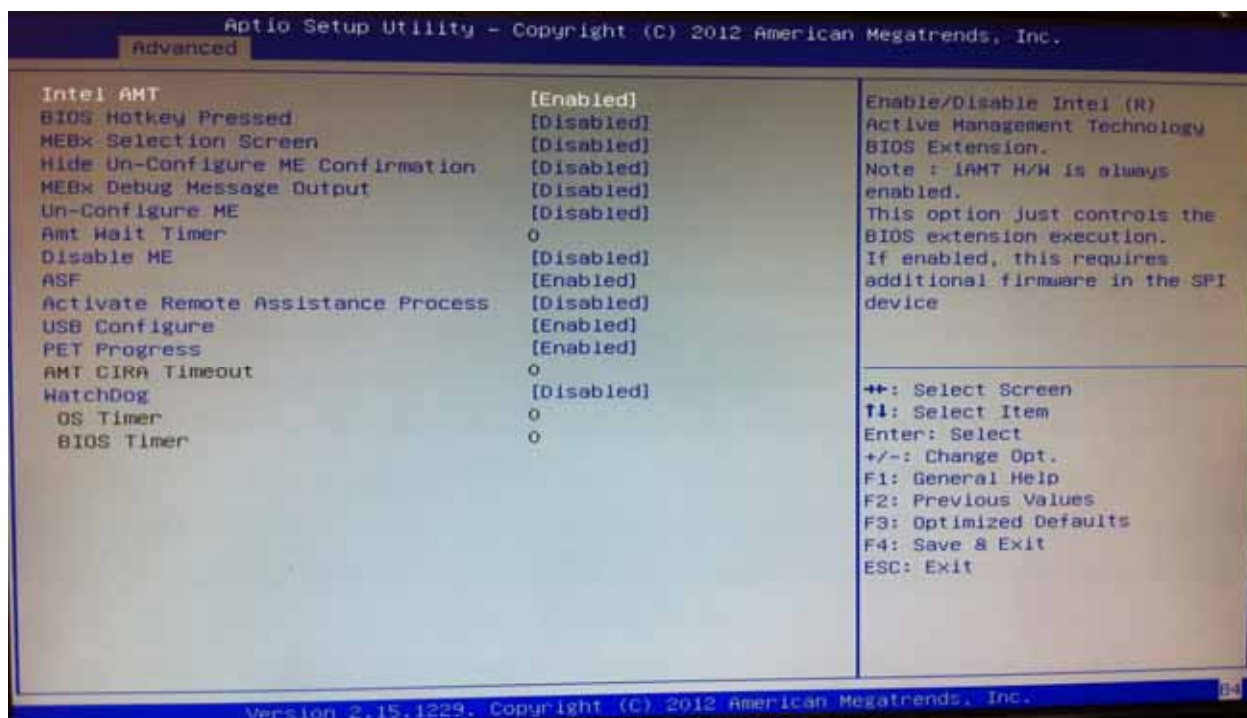

Figure. 23 AMT Configuration setting

- **USB Configuration:** USB Configuration Parameters.
 - **Legacy USB Support:** Enable Legacy USB support. AUTO option disables legacy support if no USB devices are connected. DISABLE option will keep USB devices available only for EFI applications
 - **EHCI Hand-off:** This is a workaround for OSes without EHCI hand-off support. The EHCI ownership change should be claimed by EHCI driver.
 - **USB transfer time-out:** The time-out value for Control, Bulk, and Interrupt transfers. The choice: 1 sec, 5 sec, 10 sec, 20 sec
 - **Device reset time-out:** USB mass storage device Start Unit Command time-out. The choice: 10 sec, 20 sec, 30 sec, 40 sec
 - **Device power-up delay:** USB mass storage device Start Unit Command time-out.

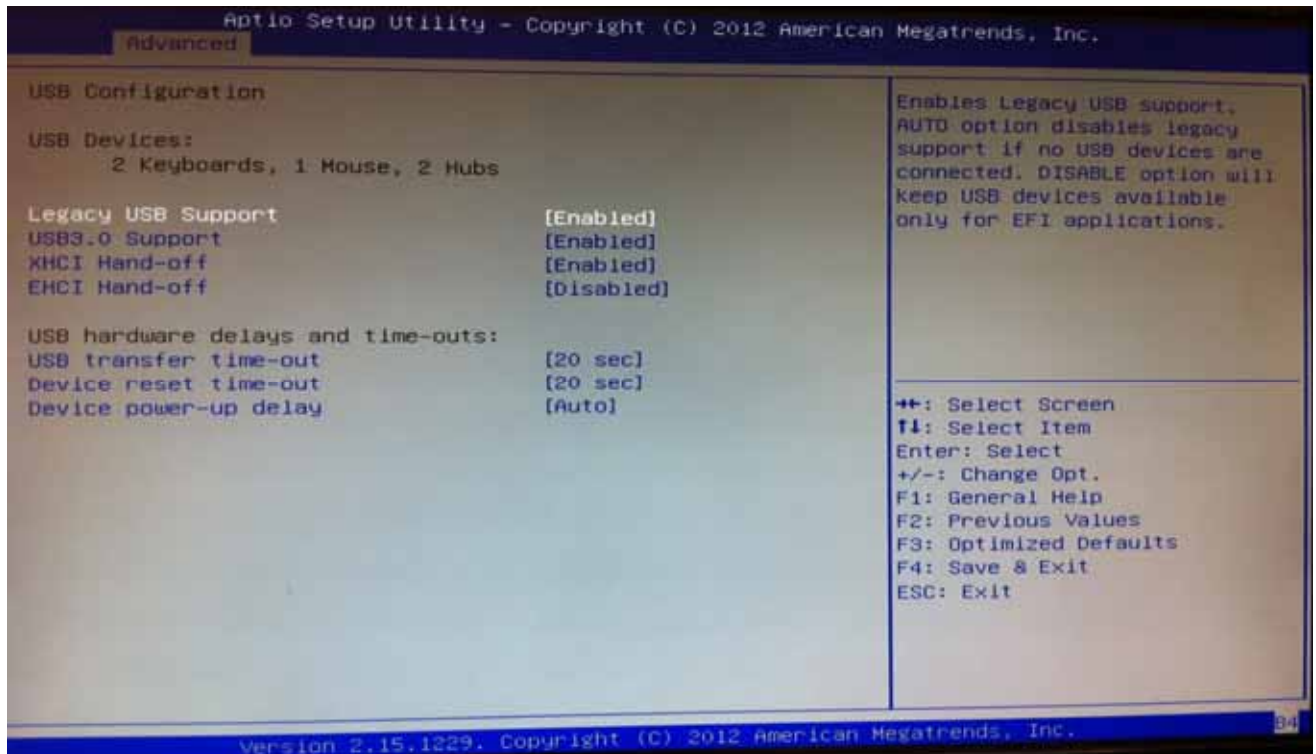

Figure. 24 USB Configuration setting

- **Serial Port 0 Configuration:** Set Parameters of Serial port 0 (COM)

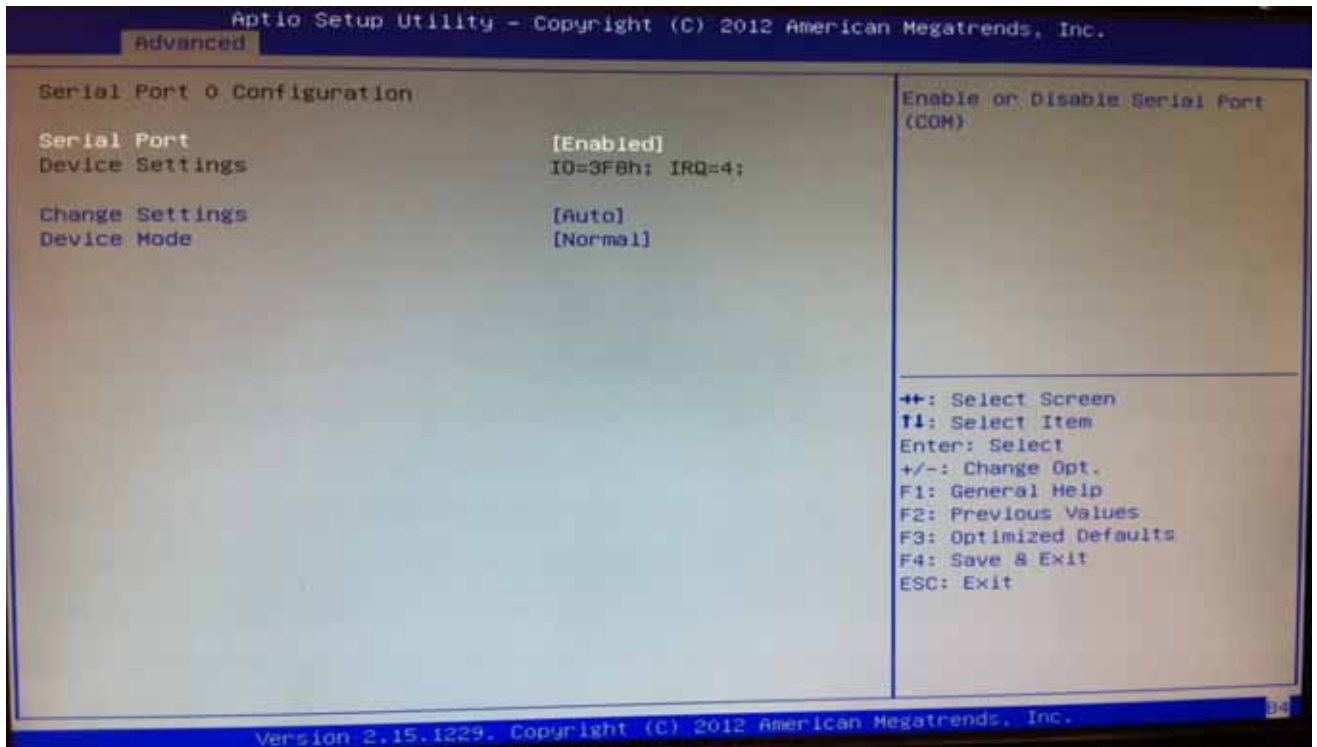

Figure. 25 Serial Port 0 Configuration setting

- **CPU PPM Configuration:** CPU PPM Configuration Parameters
 - **EIST:** Enable/Disable Intel SpeedStep
 - **Turbo Mode:** Turbo Mode
 - **CPU C3 Report:** Enable/Disable CPU C3(ACPI C2) report to OS



Figure. 26 CPU PPM Configuration setting

3.2.3 Chipset BIOS Feature Setup

Select the Chipset tab from the DS-561 setup screen to enter the Chipset BIOS Setup screen. Users can select any item in the left frame of the screen, such as PCH-IO Configuration and System Agent Configuration.

3.2.4 Security BIOS Feature Setup

Select the BOOT tab from the setup screen to enter the Security BIOS Setup screen.

- **Administrator Password:** Set up Administrator Password. When set, limits access to BIOS Setup.
- **User Password:** Set User Password. When set, limits machine boot and access to BIOS Setup.

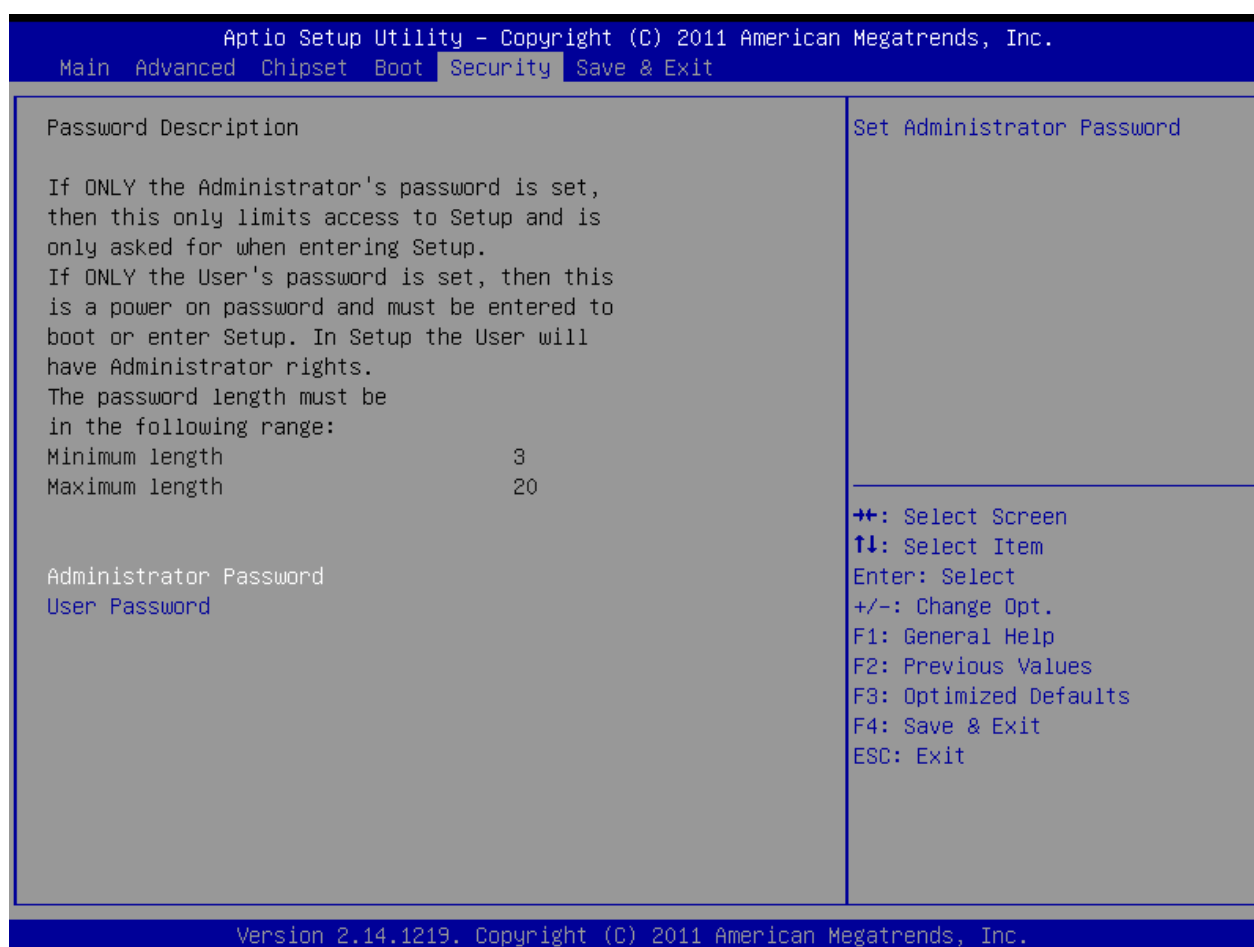

Figure. 27 Security BIOS

3.2.5 Save & Exit BIOS Feature Setup

Select the BOOT tab from the setup screen to enter the save BIOS Setup screen.

- **Save Changes and Exit:** Exit system setup after saving the changes.
- **Discard Changes and Exit:** Exit system setup without saving any changes.
- **Save Changes and Reset:** Reset the system after saving the changes.
- **Discard Changes and Reset:** Reset system setup without saving any changes.

- **Save Changes:** Save Changes done so far to any of the setup options.
- **Discard Changes:** Discard Changes done so far to any of the setup options.
- **Restore Defaults:** Restore/Load Defaults values for all the setup options.
- **Save as User Defaults:** Save the changes done so far as User Defaults.
- **Restore User Defaults:** Restore the User Defaults to all the setup options.

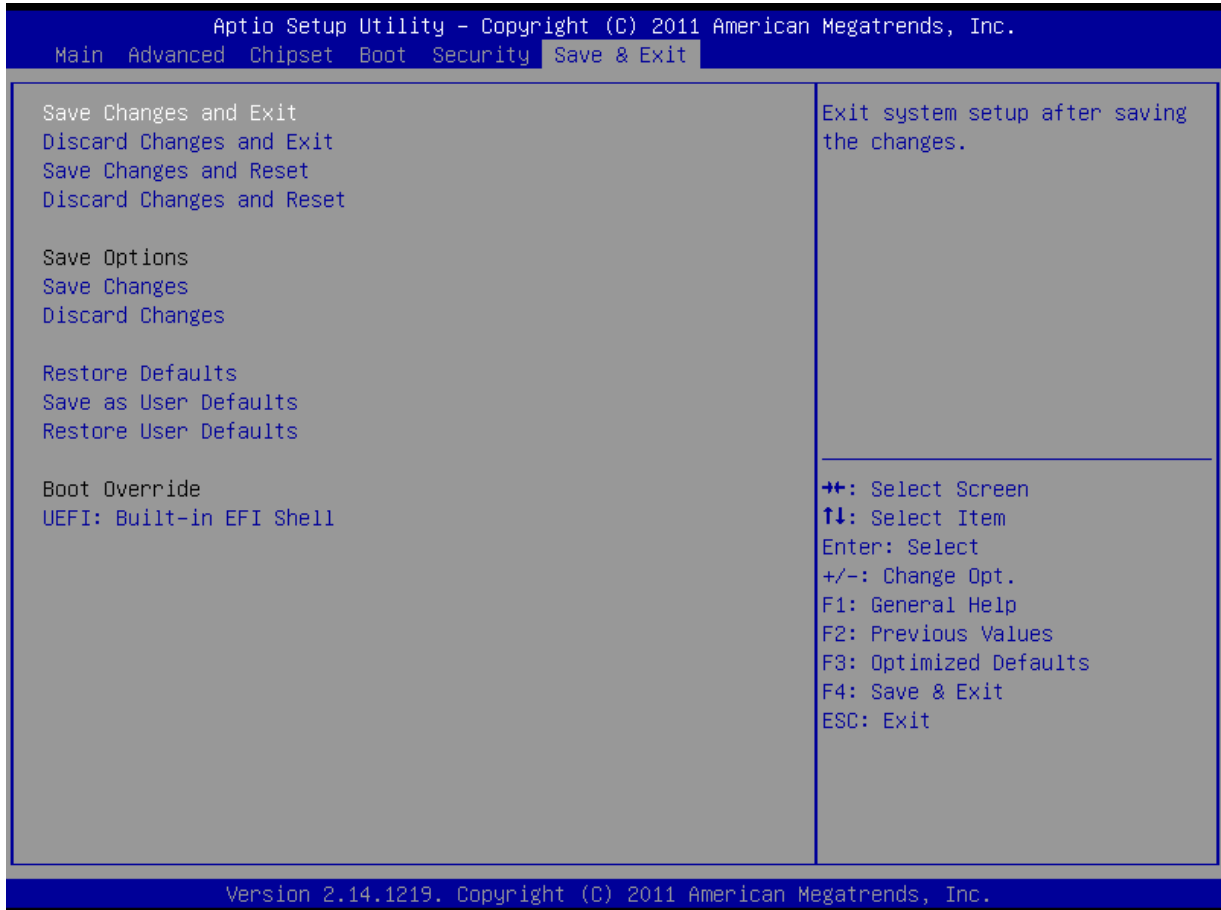

Figure. 28 Save & Exit BIOS Feature Setup

Figure. 29 warning message about system protection

FCC RF Radiation Exposure Statement:

1. This Transmitter must not be co-located or operating in conjunction with any other antenna or transmitter.
2. This equipment complies with FCC RF radiation exposure limits set forth for an uncontrolled environment. This equipment should be installed and operated with a minimum distance of 20 centimeters between the radiator and your body.