

HIT-W121

Computer

ADVANTECH

Enabling an Intelligent Planet

Copyright

The documentation and the software included with this product are copyrighted 2011 by Advantech Co., Ltd. All rights are reserved. Advantech Co., Ltd. reserves the right to make improvements in the products described in this manual at any time without notice. No part of this manual may be reproduced, copied, translated or transmitted in any form or by any means without the prior written permission of Advantech Co., Ltd. Information provided in this manual is intended to be accurate and reliable. However, Advantech Co., Ltd. assumes no responsibility for its use, nor for any infringements of the rights of third parties, which may result from its use.

Acknowledgements

Intel and Pentium are trademarks of Intel Corporation.

Microsoft Windows and MS-DOS are registered trademarks of Microsoft Corp.

All other product names or trademarks are properties of their respective owners.

Declaration of Conformity

FCC Class B

Note: This equipment has been tested and found to comply with the limits for a Class B digital device, pursuant to part 15 of the FCC Rules. These limits are designed to provide reasonable protection against harmful interference in a residential installation. This equipment generates, uses and can radiate radio frequency energy and, if not installed and used in accordance with the instructions, may cause harmful interference to radio communications. However, there is no guarantee that interference will not occur in a particular installation. If this equipment does cause harmful interference to radio or television reception, which can be determined by turning the equipment off and on, the user is encouraged to try to correct the interference by one or more of the following measures:

- ④ Reorient or relocate the receiving antenna.
- ④ Increase the separation between the equipment and receiver.
- ④ Connect the equipment into an outlet on a circuit different from that to which the receiver is connected.
- ④ Consult the dealer or an experienced radio/TV technician for help.

Warning! *Any changes or modifications made to the equipment which are not expressly approved by the relevant standards authority could void your authority to operate the equipment.*



Caution! *Danger of explosion if battery is incorrectly replaced. Replace only with the same or equivalent type recommended by the manufacturer. Dispose of used batteries according to the manufacturer's instructions.*



Technical Support and Assistance

1. Visit the Advantech web site at www.advantech.com/support where you can find the latest information about the product.
2. Contact your distributor, sales representative, or Advantech's customer service center for technical support if you need additional assistance. Please have the following information ready before you call:
 - Product name and serial number
 - Description of your peripheral attachments
 - Description of your software (operating system, version, application software, etc)
 - A complete description of the problem
 - The exact wording of any error messages

- Warning!**
1. *Packing: Please carry the unit with both hands; handle with care.*
 2. *Maintenance: to properly maintain and clean the surfaces, use only approved products or clean with a dry applicator.*



Safety Instructions

1. Read these safety instructions carefully.
2. Keep this User Manual for later reference.
3. Disconnect this equipment from any AC outlet before cleaning. Use a damp cloth. Do not use liquid or spray detergents for cleaning.
4. For plug-in equipment, the power outlet socket must be located near the equipment and must be easily accessible.
5. Keep this equipment away from humidity.
6. Put this equipment on a reliable surface during installation. Dropping it or letting it fall may cause damage.
7. The openings on the enclosure are for air convection. Protect the equipment from overheating. **DO NOT COVER THE OPENINGS.**
8. Make sure the voltage of the power source is correct before connecting the equipment to the power outlet.
9. Position the power cord so that people cannot step on it. Do not place anything over the power cord.
10. All cautions and warnings on the equipment should be noted.
11. If the equipment is not used for a long time, disconnect it from the power source to avoid damage by transient overvoltage.
12. Never pour any liquid into an opening. This may cause fire or electrical shock.
13. Never open the equipment. For safety reasons, the equipment should be opened only by qualified service personnel.
14. If one of the following situations arises, get the equipment checked by service personnel:
 - a. The power cord or plug is damaged.
 - b. Liquid has penetrated the equipment.
 - c. The equipment has been exposed to moisture.
 - d. The equipment does not work well, or you cannot get it to work according to the user's manual.
 - e. The equipment has been dropped and damaged.
 - f. The equipment has obvious signs of breakage.
15. **DO NOT LEAVE THIS EQUIPMENT IN AN ENVIRONMENT WHERE THE STORAGE TEMPERATURE MAY GO BELOW -20° C (-4° F) OR ABOVE 60° C (140° F). THIS COULD DAMAGE THE EQUIPMENT. THE EQUIPMENT SHOULD BE IN A CONTROLLED ENVIRONMENT.**
16. If your computer clock loses a significant amount of time or the BIOS configuration resets to default, the battery has no power.

Caution! 1. *Do not replace power adaptor yourself. Please contact a qualified technician or your retail.*



2. *The computer is provided with a battery-powered real-time clock circuit. There is a danger of explosion if battery is incorrectly replaced. Replace only with same or equivalent type recommended by the manufacture. Discard used batteries according to the manufacturer's instructions*
3. *Cleaning: During normal use of the HIT-W121 may become soiled and should, therefore, be cleaned regularly. Agents: Alcohol or water.*
4. *End of Product: for Environmental protection, please follow national requirements to dispose of unit.*

17. CLASSIFICATION:
- Supplied by Class I adapter
 - No applied parts
 - Continuous operation
 - No AP or APG category
18. Follow national requirements to dispose of unit.
19. Maintenance: To properly maintain and clean the surfaces, use only approved products or clean with a dry cloth.
20. Contact information:
No.1, Alley 20, Lane 26, Rueiguang Road Neihu District, Taipei, Taiwan 114,
R.O.C
TEL: (02) 2792-7818
- 21.



Medical Equipment
With Respect to Electric Shock,
Fire, and Mechanical Hazards Only,
In Accordance with UL 60601-1,
CAN/CSA C22.2 No. 601.1

22. This equipment is not to be used as a life support system.
23. Accessory equipment connected to the analog and digital interfaces must be in compliance with the respective nationally harmonized IEC standards (i.e. IEC 60950 for data processing equipment, IEC 60065 for video equipment, IEC 61010-1 for laboratory equipment, and IEC 60601-1 for medical equipment.) Furthermore all configurations must comply with the system standard IEC 60601-1-1. Anyone who connects additional equipment to the signal input part or signal output part is configuring a medical system, and is therefore, responsible that the system complies with the requirements of the system standard IEC 60601-1-1. The unit is for exclusive interconnection with IEC 60601-1 certified equipment in the patient environment and IEC 60XXX certified equipment outside of the patient environment. If in doubt, consult the technical services department or your local representative.
24. A user must not allow SIP/SOPs and the patient to come into contact with one another at the same time.
25. The sound pressure level at the operator's position according to IEC 704-1:1982 is no more than 70dB (A).

DISCLAIMER: This set of instructions is given according to IEC 704-1. Advantech disclaims all responsibility for the accuracy of any statements contained herein.

Note! Attention, please thoroughly consult the accompanying documentation.

Caution! This product: HIT-W121 is only used with the qualified & certificated power adapter listed below:



Medical: SINPRO ELECTRONICS CO LTD, model: MPU50-107, Output: 16-21Vdc, 50W max (SET UP19Vdc, 2.63A).

ITE: FSP GROUP INC, model: FSP065-RAB, Output: 19Vdc, 3.42A.

ITE: FSP GROUP INC, model: FSP040-RAB, Output: 19Vdc, 2.1A .



ISO 7010-M002 : Refer to instruction manual/booklet



IEC 60878 : Follow operating instructions or Consult instructions for use

Environmental protection

- Follow national requirements to dispose of unit.

Contents

Chapter	1	Introduction.....
	1.1	Overview
	1.2	System Configuration.....
Chapter	2	Hardware Description
	2.1	General Specifications
	2.2	Mechanical Specifications.....
		2.2.1 Mechanical Specifications (Terminal)
		2.2.2 Mechanical Drawing for Rear I/O.....
	2.3	External View
		2.3.1 Front View.....
		2.3.2 Side & Bottom View
		2.3.3 Rear View
Chapter	3	Software Description.....
	3.1	Windows XP Embedded Software Specifications.....
Chapter	4	Design Requirements.....
	4.1	Environmental Specifications.....
	4.2	Reliability.....
Annex			

1

Chapter

1.1 Overview

The HIT-W121 Healthcare Infotainment Terminal is Advantech's standard product with a built-in Windows XP Embedded OS. In addition to providing hospital bedside patient information, remote monitoring, and care functions, the CPU and the LAN-enabled architecture of the HIT-W121 terminal also serves as an integrated hospital gateway device. The HIT-W121 equipped with an Intel Atom 1.6GHz Dual-core processor, 11.6" W Full-Flat touch screen, onboard isolated Giga-LAN port and COM port, plus with other common IO such like USB and Line-in & MIC..etc. which plays a key role as a hospital bedside care and monitoring solution. It connects the service calls and LED light signals of a hospital room through the LAN to the hospital.



1.2 System Configuration

The block diagram of a HIT-W121 Healthcare Infotainment Terminal based on Hospital bedside environment is shown in the following diagram:

HIT-W121 SYSTEM DIAGRAM

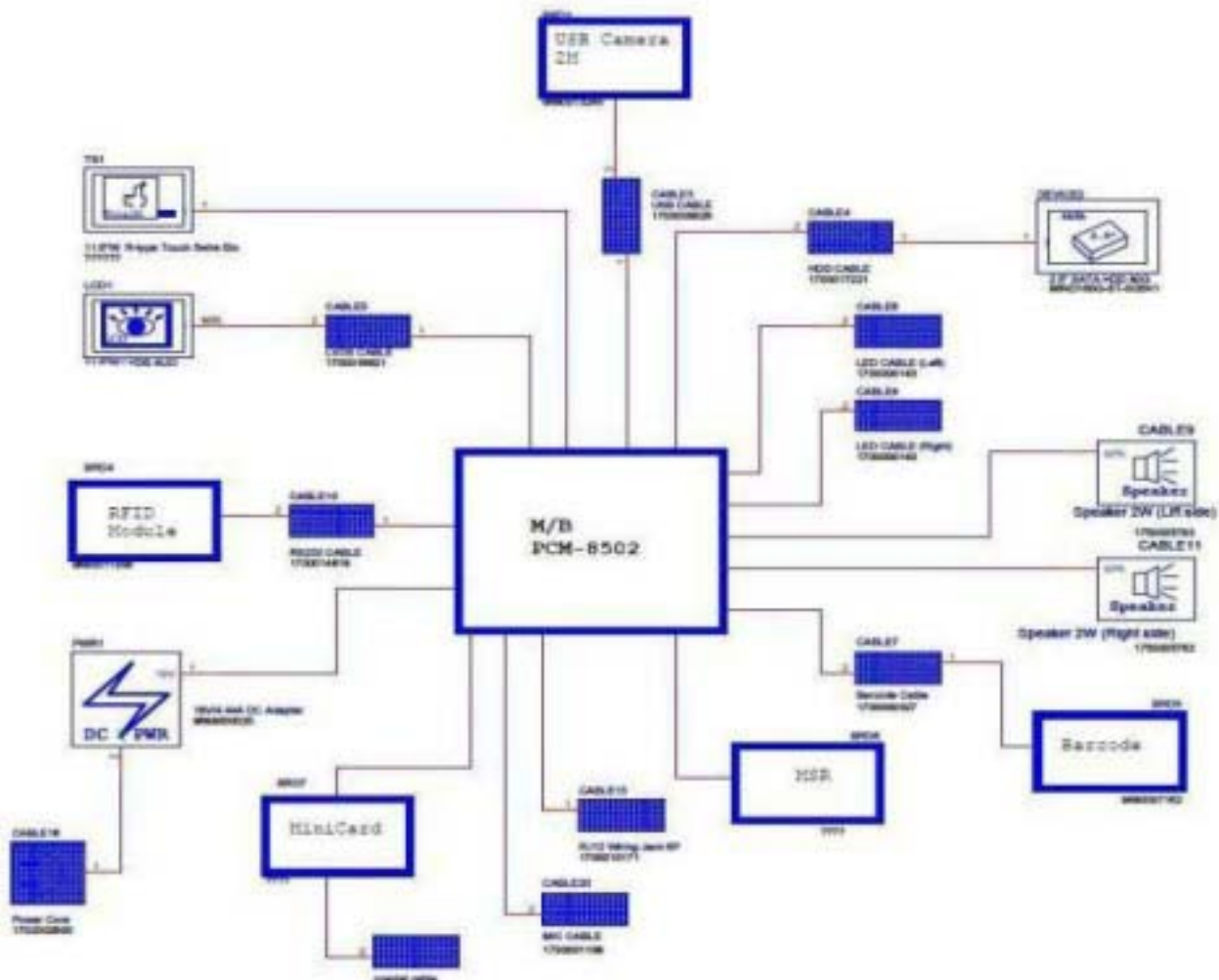

Chapter

2

2.1 General Specifications

Specifications

Hardware	CPU	Intel Atom (N450/D510) 1.6 GHz Processor
	Front Side Bus	Supports FSB 667 MHz
	System Chipset	Intel N450/D510 + ICH8M
	Memory	DDR2 667 200pin SO-DIMM
	Storage	CF or SATA HDD interface
	Camera	2 megapixel CCD Module (Optional)
	Bus Expansion	Mini PCIe x 2
Display	Size	11.6" W TFT
	Max Resolution	1366 x 768
	Luminance	200 cd/m ²
	Contrast Ratio	400:1
Touchscreen	Type	Analog Resistive
	Light Transmission	80%
	Durability	30 million
I/O Ports	USB Port	3 (side x 2, rear x 1)
	Smart Card Reader	1
	Line out	1
	Microphone in	1
	COM Port (Isolated)	1
Audio	Speaker	2 watt x 2
	Microphone	1
Network	LAN	10/100/1000 RJ-45 x 1
	WLAN	802.11 b/g/n
Emergency Alarm	Hotkey	5 programmable touch buttons with 2 types of artwork
	LED Light Indicator	1
Bus Expansion	mini-PCI Slot	2 (1 for WLAN, 1 for tuner)
Software	Operating System	Optional (WES/Linux-Fedora 13, Ubuntu)
Mechanical	Mounting	VESA 75 x 75 mm
	Dimensions (W x H x D)	302.5 x 220.25 x 43 mm
	Weight	3.3 kg
Options	Handset	Optional
	Barcode Scanner	Optional
	Table Stand	Optional
Power Supply	AC/DC Adapter	
	Input Voltage	100 – 240 V _{AC} , 1.5 A~1.35 A @ 47~ 63 Hz
	Output Voltage	IT: 19 V _{DC} , 2.1 A ; Medical: 16 – 21 V _{DC} (SET UP 19V), 2.63 A
Environment	Operating Temperature	0 – 40° C
	Vibration	1 G
	Shock	50 G
	Certifications	CE, FCC, CCC, CB, ITE UL, EN 60950 & EN 60601-1 approved

Operating Humidity: 20% to 90% (No Condensation)

Operating Atmospheric Pressure: 700 to 1060 hPa

Storage Humidity: 10% to 95% (No Condensation)

Storage Atmospheric Pressure: 700 to 1060 hPa

Transportation Temperature: -20°C to 60°C

Transportation Humidity: 10% to 95% (No Condensation)

Transportation Atmospheric Pressure: 700 to 1060 hPa

2.2 Mechanical Specifications

2.2.1 Mechanical Specifications (Terminal)

- ④ **System Dimensions:** 302.5 (W) x 220.25 (H) x 43.00 (D) mm

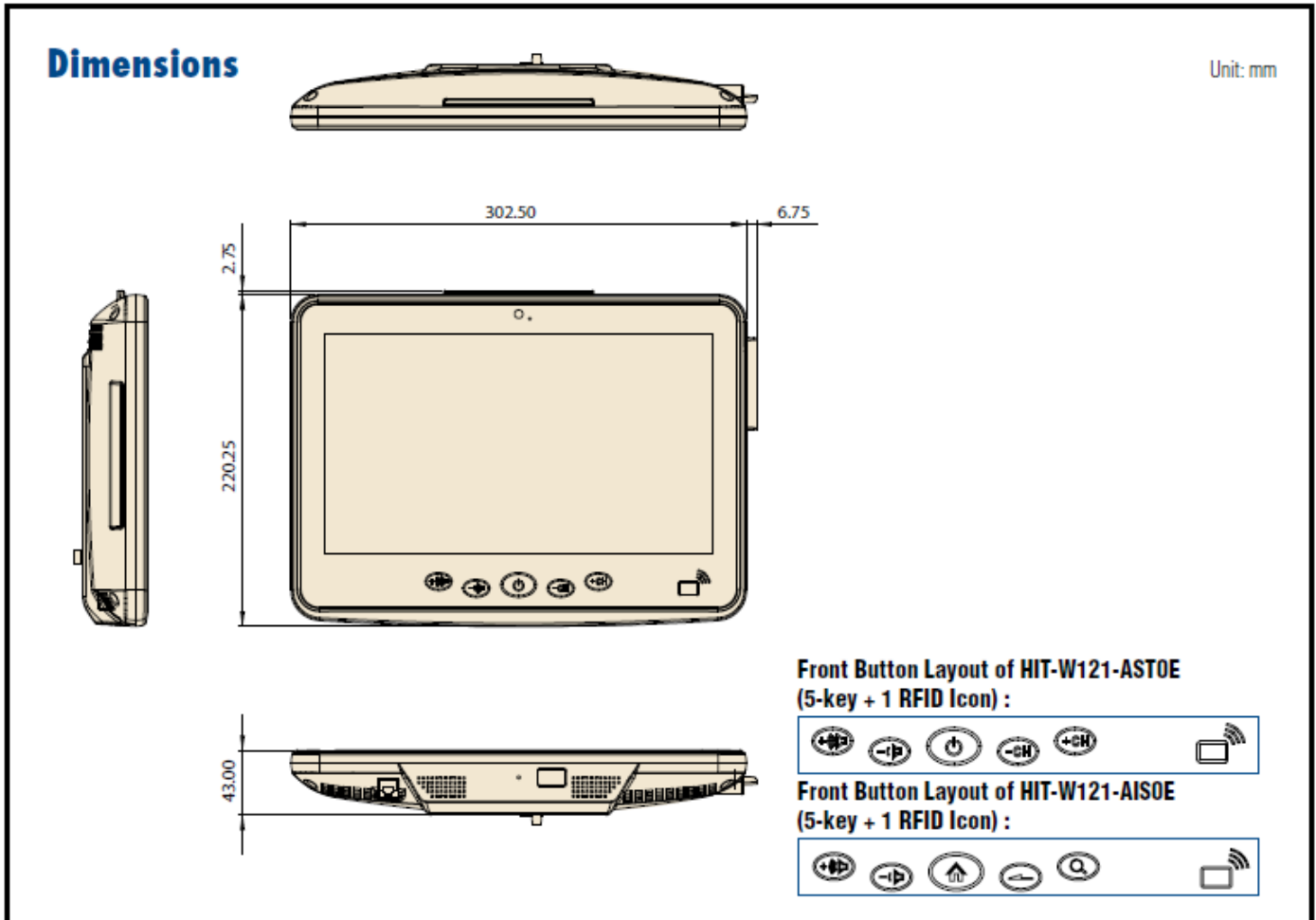

- ④ **Carton Dimensions:** 500 (W) x 385 (H) x 160
- ④ **Mounting System:** VESA 75*75mm standard mounting hole
- ④ **Net Weight:** 3 kg
VESA Mount: 75*75 mm or 100*100 mm
SCREWS: M4*10 mm

Caution Use suitable mounting apparatus to avoid risk of injury.

2.2.2 Mechanical Drawing for Rear I/O

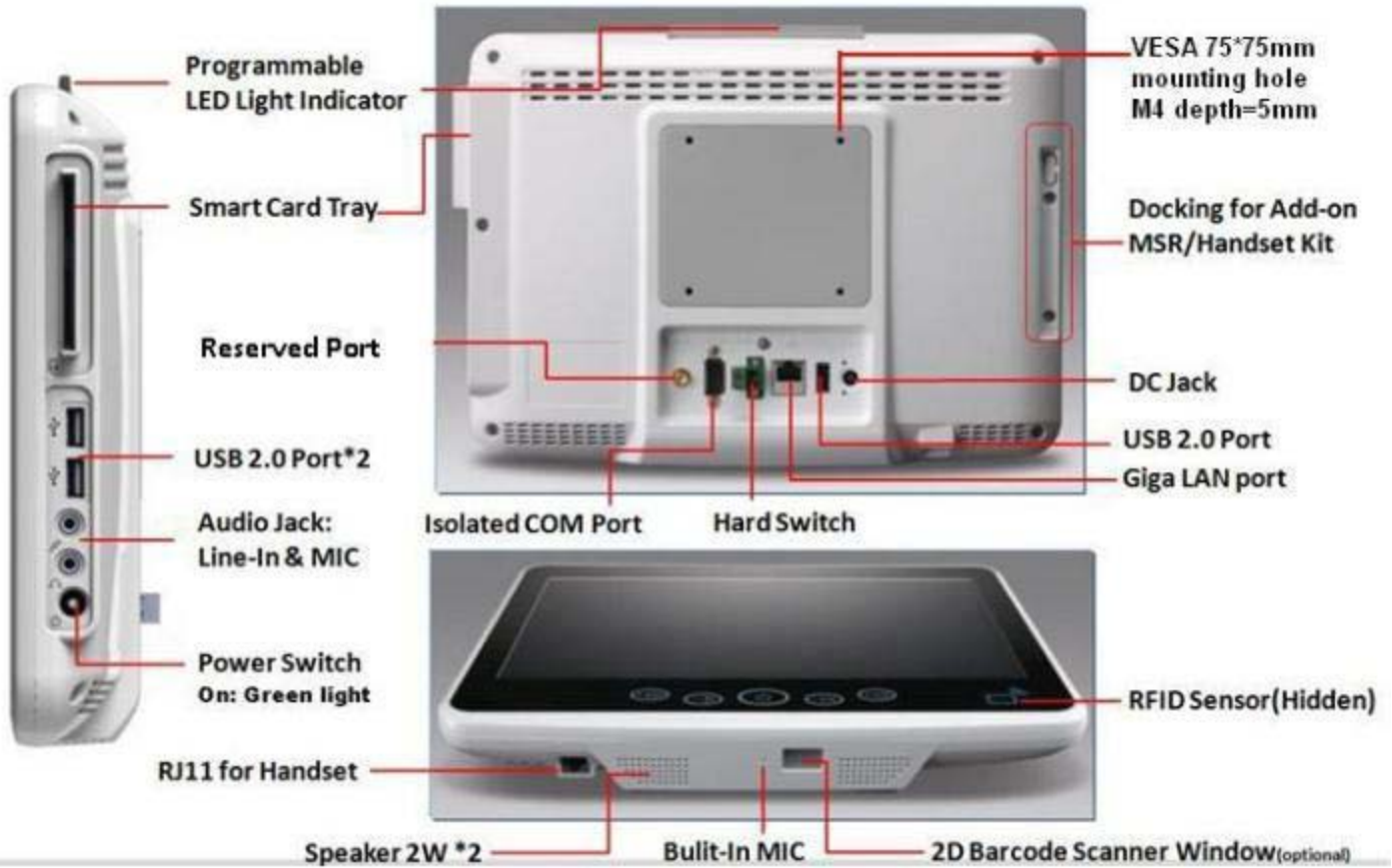

2.
2.



2.3.2 Side & Bottom View



2.3.3 Rear View

Rear View (Terminal)



3

Chapter

3.1 Windows XP Embedded Software Specifications

Real-Time OS Kernel

- ④ Windows XPE 7 Language Version

Driver List

④ Chipset	Intel ICH8M	Rev:
④ Graphics	Intel GMA500	Rev:
④ Audio	Realtek Audio ALC880	Rev: 5.10.0.5512
④ LAN	Marvell Yukon Ethernet Controller	Rev: 8.61.7.3
④ Camera	D-Max UVC Webcam	Rev: 6.11.200.4
④ Smartcard reader	ALCOR micro USB smartcard reader	Rev: 5.11.9520.7
④ Touch	Elo TtouchSys. 2216 AccuTouch@USB	Rev: 4.4.0.0
④ WLAN	SParkLan WIFI module	Rev:1.2.3.0

Embedded Application Software

- ④ Advantech SUSI

SUSI Demo Program

1. LED Indicator Control.

4

Chapter

4.1 Environmental Specifications

Temperature & Humidity

- ④ Operating Temperature: 0 ~ 40° C
- ④ Storage Temperature: 0 ~ 60° C
- ④ Relative Humidity: 0 ~ 95% RH (Non-condensed)

Case / Panel Temperature

- ④ Less than 40° C @ 25° C ambient temperature (front bezel)

Safety

- ④ CE

EMI

- ④ FCC class B approved

Vibration:

- ④ 10 ~ 18 Hz, 1.5 mm peak-to-peak displacement
- ④ 18 ~ 500 Hz, 1 G acceleration

4.2 Reliability

MTBF

- ④ 30,000 hours

Touchscreen

- ④ 10 million touch actuation times on a single point
- ④ **Power Requirements**
- ④ DC Input Voltage: 19 V
- ④ Power Consumption: less than 60 W

Annex

Guidance and manufacturer's declaration – electromagnetic emissions		
The model HIT-W121 is intended for use in the electromagnetic environment specified below. The customer or the user of the model HIT-W121 should assure that it is used in such an environment.		
Emissions test	Compliance	Electromagnetic environment – guidance
RF emissions CISPR 11	Group 1	The model HIT-W121 uses RF energy only for its internal function. Therefore, its RF emissions are very low and are not likely to cause any interference in nearby electronic equipment.
RF emissions CISPR 11	Class B	The model HIT-W121 is suitable for use in all establishments, including domestic establishments and those directly connected to the public low-voltage power supply network that supplies buildings used for domestic purposes.
Harmonic emissions IEC 61000-3-2	Class A	
Voltage fluctuations/ flicker emissions IEC 61000-3-3	Not applicable	

Recommended separation distances between portable and mobile RF communications equipment and the model HIT-W121			
The model HIT-W121 is intended for use in an electromagnetic environment in which radiated RF disturbances are controlled. The customer or the user of the model HIT-W121 can help prevent electromagnetic interference by maintaining a minimum distance between portable and mobile RF communications equipment (transmitters) and the model HIT-W121 as recommended below, according to the maximum output power of the communications equipment.			
Rated maximum output power of transmitter W	Separation distance according to frequency of transmitter m		
	150 kHz to 80 MHz $d = 1,2\sqrt{P}$	80 MHz to 800 MHz $d = 1,2\sqrt{P}$	800 MHz to 2,5 GHz $d = 2,3\sqrt{P}$
0,01	0,12	0,12	0,23
0,1	0,38	0,38	0,73
1	1,2	1,2	2,3
10	3,8	3,8	7,3
100	12	12	23
For transmitters rated at a maximum output power not listed above, the recommended separation distance d in metres (m) can be estimated using the equation applicable to the frequency of the transmitter, where P is the maximum output power rating of the transmitter in watts (W) according to the transmitter manufacturer.			
NOTE 1 At 80 MHz and 800 MHz, the separation distance for the higher frequency range applies.			
NOTE 2 These guidelines may not apply in all situations. Electromagnetic propagation is affected by absorption and reflection from structures, objects and people.			

**Information on potential electromagnetic interference and advice on
how to avoid or minimize such interference (IEC/EN 60601-1-2:2007)**

Guidance and manufacturer's declaration – electromagnetic immunity			
The model HIT-W121 is intended for use in the electromagnetic environment specified below. The customer or the user of the model HIT-W121 should assure that it is used in such an environment.			
Immunity test	IEC 60601 test level	Compliance level	Electromagnetic environment – guidance
Electrostatic discharge (ESD) IEC 61000-4-2	±6 kV contact ±8 kV air	±6 kV contact ±8 kV air	Floors should be wood, concrete or ceramic tile. If floors are covered with synthetic material, the relative humidity should be at least 30 %.
Electrical fast transient/burst IEC 61000-4-4	±2 kV for power supply lines ±1 kV for input/output lines	±2 kV for power supply lines ±1 kV for input/output lines	Mains power quality should be that of a typical commercial or hospital environment.
Surge IEC 61000-4-5	±1 kV line(s) to line(s) ±2 kV line(s) to earth	±1 kV line(s) to line(s) ±2 kV line(s) to earth	Mains power quality should be that of a typical commercial or hospital environment.
interruptions and voltage variations on power supply input lines IEC 61000-4-11	<5 % <i>UT</i> (>95 % dip in <i>UT</i>) for 0,5 cycle 40 % <i>UT</i> (60 % dip in <i>UT</i>) for 5 cycles 70 % <i>UT</i> (30 % dip in <i>UT</i>) for 25 cycles <5 % <i>UT</i> (>95 % dip in <i>UT</i>) for 5 sec	<5 % <i>UT</i> (>95 % dip in <i>UT</i>) for 0,5 cycle 40 % <i>UT</i> (60 % dip in <i>UT</i>) for 5 cycles 70 % <i>UT</i> (30 % dip in <i>UT</i>) for 25 cycles <5 % <i>UT</i> (>95 % dip in <i>UT</i>) for 5 sec	Mains power quality should be that of a typical commercial or hospital environment. If the user of the model HIT-W121 requires continued operation during power mains interruptions, it is recommended that the model HIT-W121 be powered from an uninterruptible power supply or a battery.
Power frequency (50/60 Hz) magnetic field IEC 61000-4-8	3 A/m	3 A/m	Power frequency magnetic fields should be at levels characteristic of a typical location in a typical commercial or hospital environment.
NOTE <i>UT</i> is the a.c. mains voltage prior to application of the test level.			

Information on potential electromagnetic interference and advice on how to avoid or minimize such interference (IEC/EN 60601-1-2:2007)

Guidance and manufacturer's declaration – electromagnetic immunity			
The model HIT-W121 is intended for use in the electromagnetic environment specified below. The customer or the user of the model HIT-W121 should assure that it is used in such an environment.			
Immunity test	IEC 60601 test level	Compliance level	Electromagnetic environment – guidance
<p>Conducted RF IEC 61000-4-6</p> <p>Radiated RF IEC 61000-4-3</p>	<p>3 Vrms 150 kHz to 80 MHz</p> <p>3 V/m 80 MHz to 2,5 GHz</p>	<p>3 Vrms</p> <p>3 V/m</p>	<p>Portable and mobile RF communications equipment should be used no closer to any part of the model HIT-W121, including cables, than the recommended separation distance calculated from the equation applicable to the frequency of the transmitter.</p> <p>Recommended separation distance</p> <p>$d = 1,2 \sqrt{P}$</p> <p>$d = 1,2 \sqrt{P}$ 80 MHz to 800 MHz</p> <p>$d = 2,3 \sqrt{P}$ 800 MHz to 2,5 GHz</p> <p>where P is the maximum output power rating of the transmitter in watts (W) according to the transmitter manufacturer and d is the recommended separation distance in metres (m).</p> <p>Field strengths from fixed RF transmitters, as determined by an electromagnetic site survey,^a should be less than the compliance level in each frequency range.^b</p> <p>Interference may occur in the vicinity of equipment marked with the following symbol:</p> <div style="text-align: center;">  </div>
<p>NOTE 1 At 80 MHz and 800 MHz, the higher frequency range applies.</p> <p>NOTE 2 These guidelines may not apply in all situations. Electromagnetic propagation is affected by absorption and reflection from structures, objects and people.</p>			
<p>^a Field strengths from fixed transmitters, such as base stations for radio (cellular/cordless) telephones and land mobile radios, amateur radio, AM and FM radio broadcast and TV broadcast cannot be predicted theoretically with accuracy. To assess the electromagnetic environment due to fixed RF transmitters, an electromagnetic site survey should be considered. If the measured field strength in the location in which the model HIT-W121 is used exceeds the applicable RF compliance level above, the model HIT-W121 should be observed to verify normal operation. If abnormal performance is observed, additional measures may be necessary, such as reorienting or relocating the model HIT-W121.</p> <p>^b Over the frequency range 150 kHz to 80 MHz, field strengths should be less than 3 V/m.</p>			

FCC Caution: Any changes or modifications not expressly approved by the party responsible for compliance could void the user's authority to operate this equipment.

FCC RF Radiation Exposure Statement:

1. • This Transmitter must not be co-located or operating in conjunction with any other antenna or transmitter.
2. • This equipment complies with FCC RF radiation exposure limits set forth for an uncontrolled environment. This equipment should be installed and operated with a minimum distance of 20 centimeters between the radiator and your body.