

Semi-Rugged Tablet PC

S10A

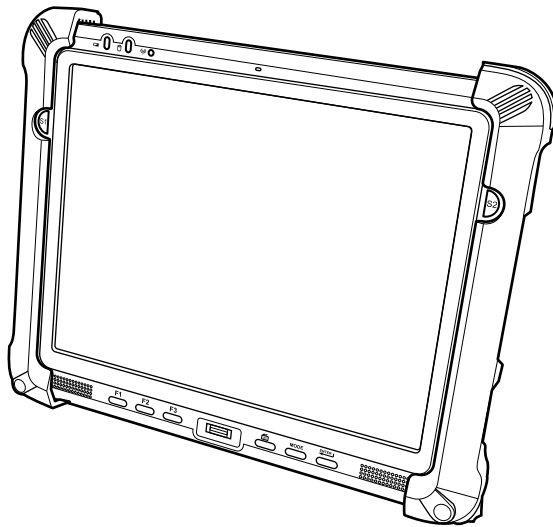

User Manual

Ver 1.0

Table of Contents

Preface	i
CE Conformity Statement	i
FCC Compliance Statement	ii
Copyright Statement	iii
Safety Instructions	iv
Battery Safety	v
RTC Battery Caution	v
Battery Pack Caution	v
Battery Charge Notice	v
Storage and Safety Notice	vi
Rugged and Ready to Go	1
Symbols Used in this Manual	1
Product Features.....	1
Package Contents.....	2
Optional Accessories	2
Optional Modules	2
Exploring the S10A.....	3
Front View.....	3
Rear View.....	5
Right View	6
Left View	6
Bottom View	7
Getting Started	8
Installing the Rubber Bumpers.....	8
Removing the Rubber Bumpers	8
Using the Power Switch	8
Inserting a Memory Card.....	9
Removing a Memory Card.....	10
Installing a GPRS Module (optional).....	11
Removing 3G SIM Card (optional)	12
Installing an MSR (optional)	13

Installing a Scanner (optional)	14
Upgrading Components.....	15
Removing the Memory	15
Replacing the Memory	15
Removing the Hard Disk Drive	16
Replacing the Hard Disk Drive	17
Removing the Battery	17
Replacing the Battery	18
Making Connections.....	19
Connecting the Power.....	19
Connecting to a Monitor.....	19
Connecting USB Devices.....	20
Connecting Headphones.....	20
Connecting a Microphone	20
Turning On.....	21
Turning On for the First Time.....	21
Controlling the S10A.....	24
Using the Touch Screen	24
Using the Control Panel Buttons	26
Using the On-Screen Keyboard	26
Configuring the Function Buttons.....	27
Using the Mode Button	27
Adjusting Screen Brightness	28
Adjusting the Volume.....	28
Wireless Connections.....	29
WiFi Connection.....	29
Configuring a New Wireless Network.....	31
Bluetooth Connections.....	33
Setting Up Bluetooth.....	33
GPRS Connection (optional).....	35
Setting Up GPRS	35
GPS Connection (optional)	37
Using the Fingerprint Software.....	38

Systems Requirements	38
Installation Wizard	38
How to Open the Fingerprint Software Menu.....	41
Verify Your Fingerprint	41
IE Auto Login	42
How to "Save Username and Password"	42
IE Auto Login Auto-Filling	44
Web Site Login and Auto Detect	45
Auto Login Database Manager	46
Sending ID and Password Automatically	46
Secure Lock	46
Secure Lock "Lock" / "Unlock Drive"	46
Resize	47
Fingerprint Security	48
Folder Security	48
File Security.....	50
User Settings.....	51
Fingerprint Registration	52
Windows Logon Setting	53
Screen Saver Lock Setting.....	54
Quick Bar Auto Hiding Setting	55
Add Another User Account's Fingerprint(s)	55
Uninstall	56
Advanced Settings.....	58
Configuring Touch Screen Function	58
Checking Battery Status	59
Power Options	60
Maintenance	61
Maintaining the Battery	61
Maintaining the LCD Display	61
Cleaning the S10A	61
Troubleshooting	62
Recovering from a System Crash (Windows XP Professional Embedded)	62

Recovering from a System Crash (Windows XP Embedded)	63
Appendix	65
Specifications	65
Optional Accessories	68
External Battery	68
Tablet PC Docking	69
Adjustable Stand	72
Handstrap and Shoulder Strap	73
Vesa Mount	75

Preface

CE Conformity Statement

Radio products with the CE alert marking comply with the R&TTE Directive (1999/5/EC) issued by the Commission of the European Community. Compliance with this directive implies conformity to the following European Norms (in brackets are the equivalent international standards).

- EN 60950-1 (IEC60950-1) - Product Safety
- EN 300 328 Technical requirement for radio equipment
- ET S301 489 General EMC requirements for radio equipment

Products that contain the radio transmitter are labeled with CE alert marking and may also carry the CE logo.

FCC Compliance Statement

This device complies with part 15 of the FCC Rules. Operation is subject to the following two conditions:

1. This device may not cause harmful interference;
2. This device must accept any interference received, including interference that may cause undesired operation.

CAUTION!	Exposure to Radio Frequency Radiation. The radiated output of this device is far below the FCC radio frequency exposure limits. Nevertheless, the device shall be used in such a manner that the potential for human contact during normal operation is minimized. When connecting an external antenna to the device, the antenna shall be placed in such a manner to minimize the potential for human contact during normal operation. In order to avoid the possibility of exceeding the FCC radio frequency exposure limits, human proximity to the antenna shall not be less than 20cm (8inches) during normal operation.
----------	---

This equipment has been tested and found to comply with the limits for a Class B digital device, pursuant to part 15 of the FCC Rules. These limits are designed to provide reasonable protection against harmful interference in a residential installation. This equipment generates, uses and can radiate radio frequency energy. If this equipment does cause harmful interference to radio or television reception, which can be determined by turning the equipment off and on, the user is encouraged to try and correct the interference by one or more of the following measures:

However, there is no guarantee that interference will not occur in a particular installation. If this equipment does cause harmful

interference to radio or television reception, which can be determined by turning the equipment off and on, the user is encouraged to try to correct the interference by one or more of the following measures:

- Reorient or relocate the receiving antenna
- Increase the separation between the equipment and receiver
- Connect the equipment into an outlet on a circuit different from that to which the receiver is connected
- Consult the dealer or an experienced computer technician for help

Copyright Statement

© Copyright 2009 ACA Digital Corporation, All Rights Reserved.

All rights reserved. This manual is protected by copyright and distributed under licenses restricting its use, copying and distribution. No part of this manual may be reproduced in any form, electronic or otherwise, without the express permission of ACA Digital Corporation.

This product features software manufactured by Advanced Convergence Alliance, along with other third party software. All described herein shall not be distributed, modified, reverse engineered, or reproduced in any manner without the prior permission of ACA Digital Corporation or of the other third parties, to whom the software rights belong.

All other product names, trademarks or logos mentioned herein and are the property of their respective owners.

Safety Instructions

Use the following safety guidelines to help protect yourself and S10A.

- Do not attempt to service the S10A yourself. Always follow installation instructions closely.
- Be sure that nothing rests on the AC adapter's power cable and that the cable is not located where it can be tripped over or stepped on.
- Do not cover the AC adaptor with papers or other items that will reduce cooling; also, do not use the AC adapter while it is inside a carrying case.
- Use only the AC adapter, power cord, and batteries that are approved for use with this S10A. Use of another type of battery or AC adapter may cause risk of fire or explosion.
- If you use an extension cable with the AC adapter, ensure that the total ampere rating of the products plugged in to the extension cable does not exceed the ampere rating of the extension cable.
- When you move the S10A between environments with very different temperature and/or humidity ranges, condensation may form on or within the S10A. To avoid damaging the S10A, allow sufficient time for the moisture to evaporate before using the S10A.
- When you disconnect a cable, pull on its connector or on its strain relief loop, not on the cable itself. As you pull out the connector, keep it evenly aligned to avoid bending any connector pins. Also, before you connect a cable make sure both connectors are correctly oriented and aligned.

CAUTION: To reduce the risk of fire, use only No.26 AWG or larger (e.g., 24 AWG) UL Listed or CSA Certified Telecommunication Line Cord.

Battery Safety

RTC Battery Caution

RISK OF EXPLOSION IF BATTERY IS REPLACED BY AN INCORRECT TYPE. DISPOSE OF USED BATTERIES ACCORDING TO THE INSTRUCTIONS.

- Do not place the battery incorrectly as this may cause danger of explosion.
- Dispose of used batteries according to the manufacturer's instructions.
- Do not dispose of batteries in a fire. They may explode. Check with local authorities for disposal instructions.

Battery Pack Caution

- The battery used in this device may present a risk of fire or chemical burn if mistreated. Do not disassemble, heat above 50°C, or incinerate. Replace internal battery with 46-12381-030 Li-ion 11.1V 1900mAh and second battery with Li-ion 11.1V 3800mAh Cell Panasonic SMP only. Use of another battery may present a risk of fire or explosion.
- Dispose of used batteries according to local disposal regulations. Keep away from children. Do not disassemble and do not dispose of in a fire.

Battery Charge Notice

It is important to consider the environment temperature whenever you are charging the Lithium-Ion battery pack. The process is more efficient at normal room temperature or slightly cooler. It is essential that you charge batteries within the stated range of 0°C to 50°C. Charging batteries outside of the specified range could damage the batteries and shorten their charging life cycle.

Storage and Safety Notice

Although charge Lithium-Ion batteries may be left unused for several months, their capacity may be depleted due to the build up of internal resistance. If this happens they will require recharging prior to use. Lithium-Ion batteries may be stored at temperatures between -20°C to 50°C , however they may be depleted more rapidly at the high end of this range. It is recommended to store batteries within normal room temperature ranges.

Rugged and Ready to Go

Congratulations on your purchase of the S10A Semi-Rugged Tablet PC. This product combines rugged design with reliable performance and powerful functionality to best suit all your needs, in a wide range of working conditions.

This user manual outlines all you need to know to set up and use your S10A. If you have any further questions or queries, contact our technical support team via our website: www.aca-digital.com.

Symbols Used in this Manual

 <p>Warning</p>	Denotes information that must be observed. Failure to do so may result in personal harm or damage to the product.
--	---

 <p>Note</p>	Denotes useful information that should be noted to ensure you get the most out of the product.
---	--

Product Features

- Rugged design
- High-performance Intel® Atom™ processor
- Built-in WLAN/Bluetooth functions
- Durable, shock-resistant magnesium alloy housing
- IP54 sealing & built to withstand a 3-foot drop
- 10.4" Sunlight option / XGA TFT LCD
- I/O ports for expansion
- Long battery life

Package Contents

Ensure all the following items are present when you receive your S10A. If any of these items are missing, contact your vendor immediately.



Screens used in this manual are for illustrative purposes only. Actual screens may vary depending on your product version.

- S10A Tablet PC
- AC power adaptor
- Power cord
- Rubber bumpers
- Second battery option
- CD

Optional Accessories

- Desk docking
- External battery
- Handstrap
- Shoulderstrap
- Bumper
- Vesa Mount

Optional Modules

- 1D / 2D barcode scanner
- MSR (1+2+3 track card reader)
- RFID 13.56M
- WWAN GPRS/3G/3.5G
- GPS module

Exploring the S10A

Front View

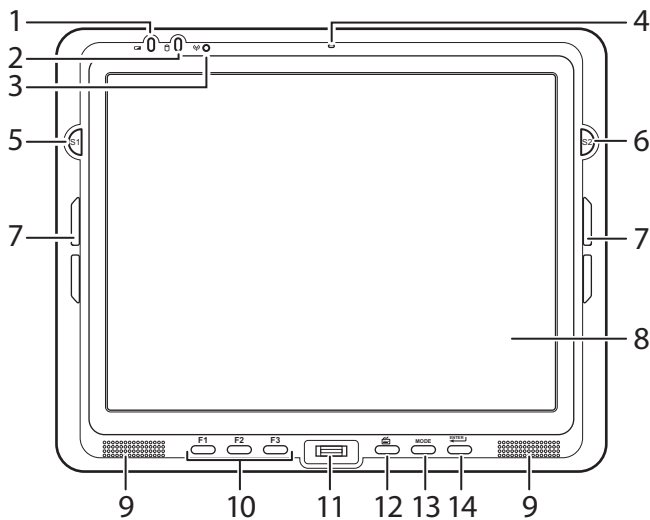

No.	Component
1	Power LED <ul style="list-style-type: none"> • Off: Power off • Solid green: Power on / When in power off mode, lights green when charging. • Blinking green: AC power on and the battery is charging
2	HDD LED <ul style="list-style-type: none"> • Lights green to indicate hard disk drive activity.
3	WLAN LED <ul style="list-style-type: none"> • Off: No RF signal / No LAN connection • Solid green: WLAN connected • Blinking green: TX/RX transmission
4	Microphone

No.	Component
5	S1 / Brightness button <ul style="list-style-type: none">• Functions as a barcode switch key when a barcode scanner is connected, otherwise, can be assigned as a function key (F4).• When mode is enabled, press to decrease brightness.
6	S2 / Brightness button <ul style="list-style-type: none">• Can be assigned as a function key (F5).• When mode is enabled, press to increase brightness.
7	Rubber bumper indents <ul style="list-style-type: none">• Lock the rubber bumpers
8	Touch-sensitive display
9	Speakers
10	Function keys
11	Fingerprint scanner
12	Keyboard button
13	Mode button
14	Enter button

Rear View

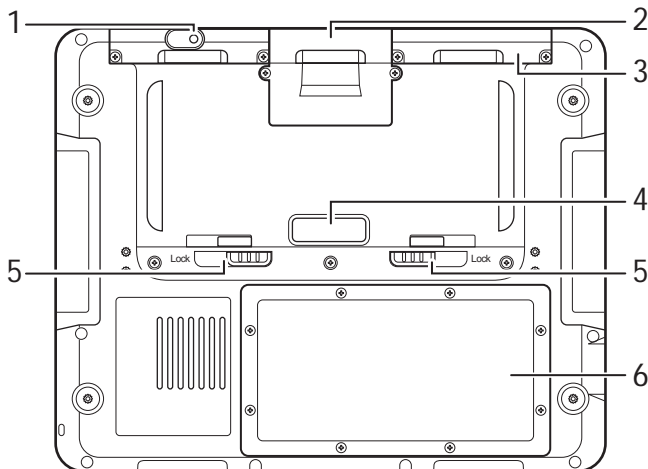

No.	Component
1	Left compartment <ul style="list-style-type: none"> • Holds the camera and the hard disk drive • Contains the barcode scanner connectors
2	Middle compartment <ul style="list-style-type: none"> • GPRS connector • SIM card slot
3	Right compartment <ul style="list-style-type: none"> • Contains connectors for MSR, RFID, or GPS module
4	External battery contacts / Power switch
5	External battery lock
6	Battery / Memory compartment

Right View

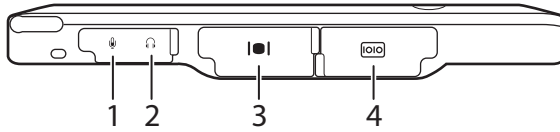

No.	Component
1	Microphone jack
2	Headphone jack
3	VGA port
4	Serial port

Left View

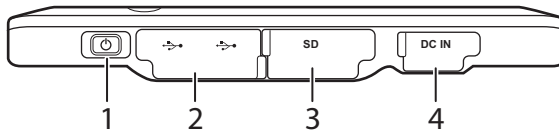

No.	Component
1	Power button
2	USB ports (2)
3	SD card slot
4	DC-in jack

Bottom View

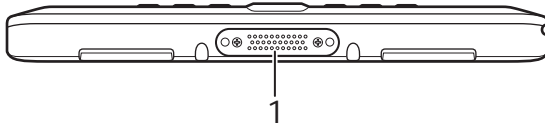

No.	Component
1	Docking connector

Getting Started

Installing the Rubber Bumpers

To protect the housing case of S10A, install the rubber bumpers.

1. Install the rubber bumpers on the left and right side of S10A.
2. Make sure the rubber bumpers are aligned and locked on the indents.

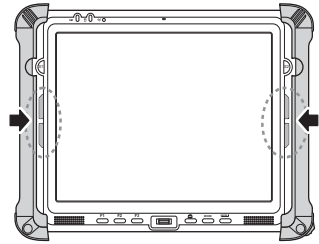

Removing the Rubber Bumpers

From the rear of the tablet PC, remove the rubber bumpers.

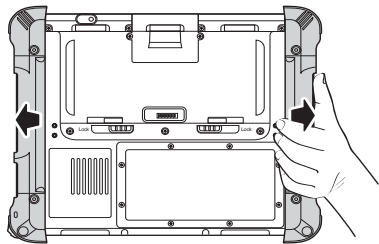

Using the Power Switch

The power switch, located next to the external battery contacts, controls the flow of power of your S10A. By default, the power switch is set on the left.

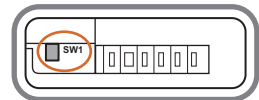

To reveal the power switch, remove the external battery contacts cover.

- To cut off power flow - switch to the left
- To allow power flow - switch to the right

Inserting a Memory Card

You can insert an SD card to store data, which needs to be later transferred to another machine, or to simply expand the storage capacity of the S10A. You can use SD cards up to 8GB in size.

1. Open the SD card compartment cover.

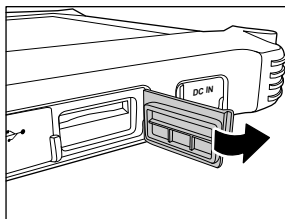

2. Insert the SD card with the metal contacts facing upwards, until it clicks into place.

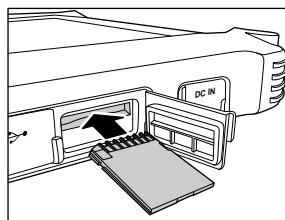

3. Close the memory card compartment cover.

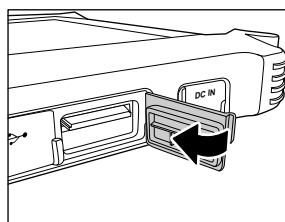

Removing a Memory Card

1. Open the SD card compartment cover.

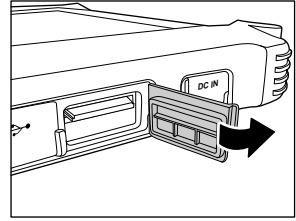

2. Press the SD card inwards to eject it from the slot.

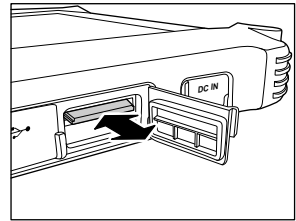

3. Remove the card and close the SD card compartment cover.

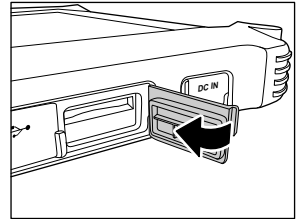

Installing a GPRS Module (optional)

1. Make sure the system is turned off. Unscrew the middle compartment cover.

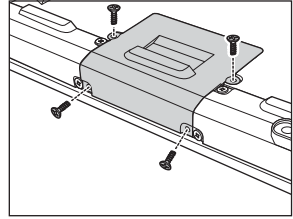

2. Align and insert the connector of the GPRS module with the connector in the compartment.

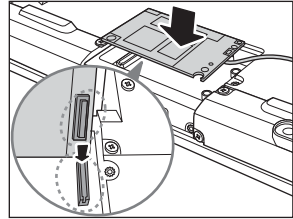

3. Remove the adhesive cover of the antenna.

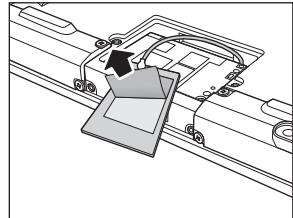

4. Tape the adhesive at the back of middle compartment cover to secure the antenna.

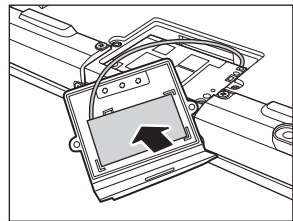

5. Screw to secure the GPRS module inside the compartment.

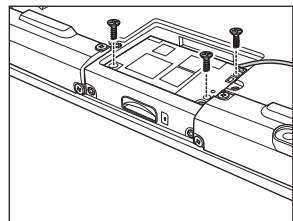

6. Push the SIM card into the slot, with the metallic part facing up and the clipped corner facing inward, until it clicks into place.

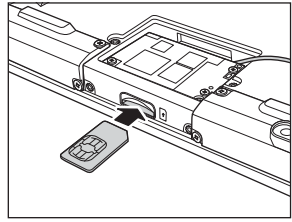

7. Screw the middle compartment cover.

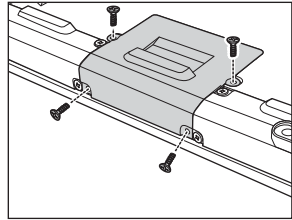

Note

To use the GPRS function, you need to setup and activate the ethernet adapter. See "GPRS Connection (optional)" on page 35.

Removing 3G SIM Card (optional)

Slightly push the SIM Card inwards to pop it out.

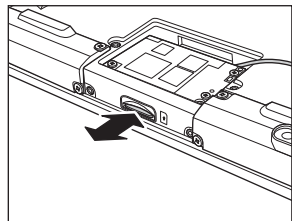

Installing an MSR (optional)

1. Make sure the system is turned off.
2. Unscrew the right compartment cover to remove.

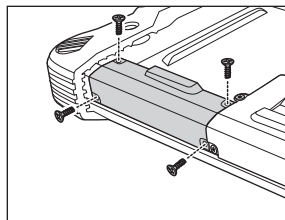

3. Attach the MSR connector to the connectors inside the compartment.
4. Screw to secure the MSR module onto the tablet PC.

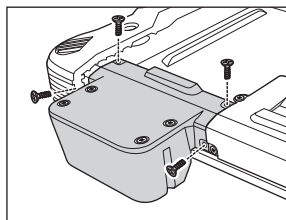

Installing a Scanner (optional)

The 1D or 2D barcode scanner module comes with a 2M CCD camera.

1. Make sure the system is turned off.
2. Unscrew the left compartment cover.

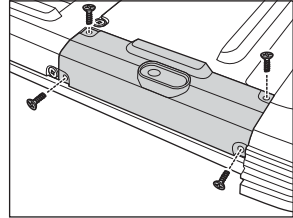

3. Remove the camera connector.

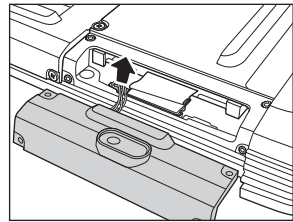

4. Attach the scanner connector to the connector inside the compartment.

5. Screw to secure the scanner module onto the tablet PC.

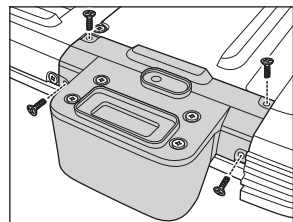

Upgrading Components

Removing the Memory

1. Make sure the system is turned off.
2. Move the power switch to the left to ensure battery power is completely cut off. See “Using the Power Switch” on page 8.
3. Unscrew the memory compartment cover.



4. Release the retaining clips to eject the memory from the socket.

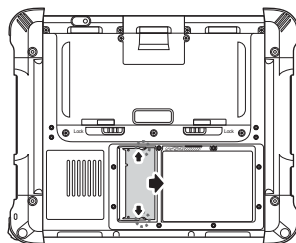
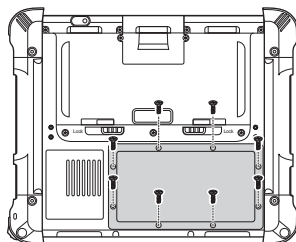

Replacing the Memory

1. Gently push new memory into the socket until the retaining clips click into place.

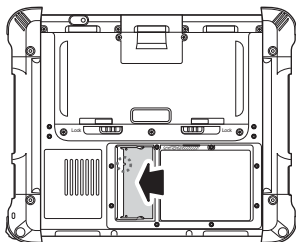

2. Screw the memory compartment cover back.

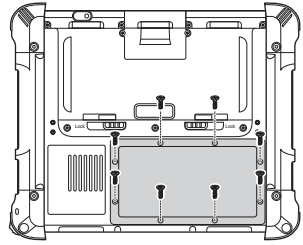

Removing the Hard Disk Drive

S10A comes with an 80G PATA hard disk drive. If more space is required for your application or there is a need to transport the hard disk content, follow the steps below to remove the hard disk drive.

1. Make sure the system is turned off.
2. Move the power switch to the left to ensure battery power is completely cut off. See "Using the Power Switch" on page 8.
3. Unscrew the left compartment cover.
4. Remove other connectors, such as camera.
5. Lift to remove the hard disk drive connector.
6. Pull out the hard disk drive.

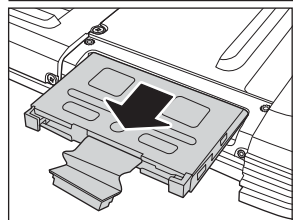
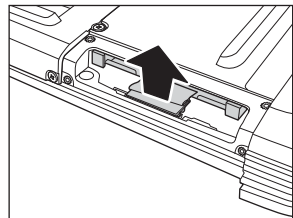
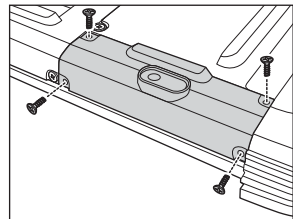
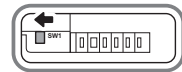

Replacing the Hard Disk Drive

1. Insert the hard disk into the slot with the connector facing down.
2. Connect the hard disk connector.
3. Screw the left compartment cover back.

Removing the Battery

1. Make sure the system is turned off.
2. Move the power switch to the left to ensure battery power is completely cut off. See “Using the Power Switch” on page 8.
3. Unscrew the battery compartment cover.
4. Remove the battery connector.
5. Lift the battery off the compartment.

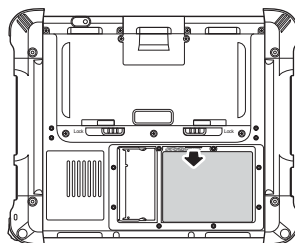
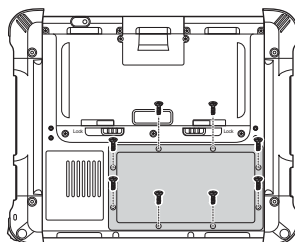
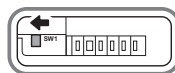

Replacing the Battery

1. Connect the battery connector to the connector inside the compartment.
2. Place the battery inside the compartment.
3. Screw the battery compartment cover back.

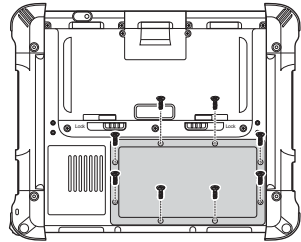
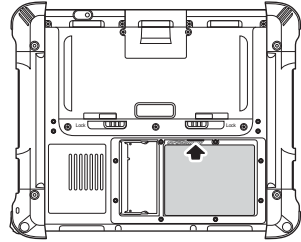

Making Connections

Connecting the Power

Before you can use your S10A, you must fully charge the battery. Connect the power adapter as shown and leave to charge for:

- a minimum of 4 hours when using the internal battery
- a minimum of 8 hours when a second battery is installed

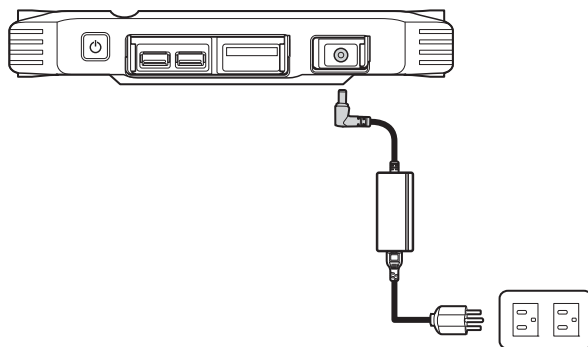

Connecting to a Monitor

You can connect the S10A to an external monitor for enhanced viewing.

Connect one end of a VGA cable to the VGA port on the right side of the S10A. Connect the other end to the VGA port on the monitor.

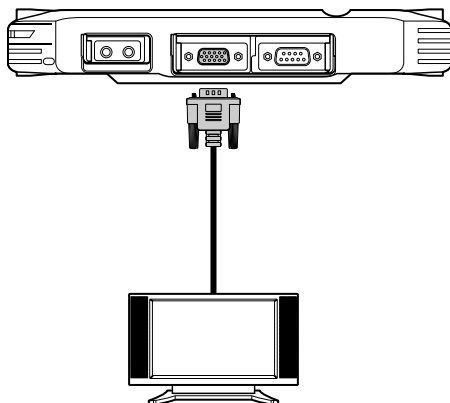

Connecting USB Devices

You can connect peripheral devices, such as a USB keyboard and mouse, as well as other wireless devices using the USB ports on the left side of the S10A.

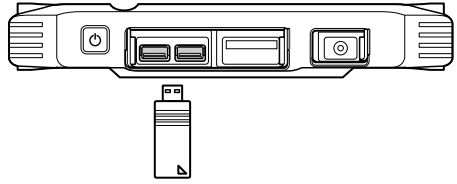

Connecting Headphones

You can connect a pair of headphones using the headphone jack on the right side of the S10A.

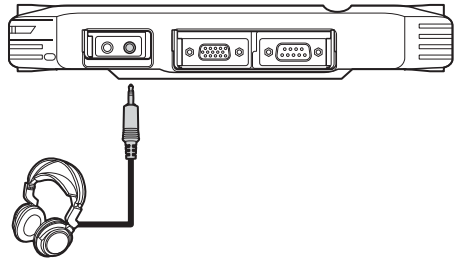

Connecting a Microphone

The S10A features a built-in microphone, but you can still connect an external microphone if needed. Connect the microphone to the microphone jack on the right side of the S10A as shown.

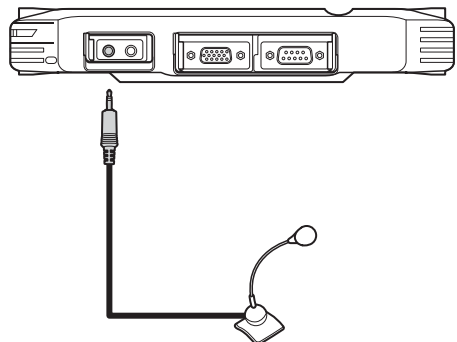

Turning On

1. Move the power switch to the right.

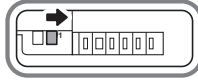

2. Press and hold the power button to turn on the S10A.

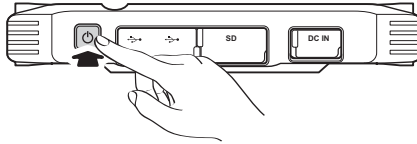

Turning On for the First Time

(If you are using Windows XP Professional Embedded)

When you first turn on the S10A, the following setup screens will appear. Follow these instructions to validate your version of Windows XP and set up your system correctly.

1. The Welcome screen appears. Tap **Next** to continue.
2. Tap **Yes, I accept** to agree to the terms and conditions. Tap **Next** to continue.



3. Enter the 25-digit product key to validate your copy of Windows. Tap **Next** to continue.
4. Enter a name to identify your S10A. This is the name by which it will be recognized on all connected networks. You can also enter a description if required. Tap **Next** to continue.
5. Enter an administrator password and re-confirm. Tap **Next** to continue.
6. Choose whether or not to make the S10A part of a domain. If so, enter the domain name (ask your system administrator for details). Tap **Next** to continue.

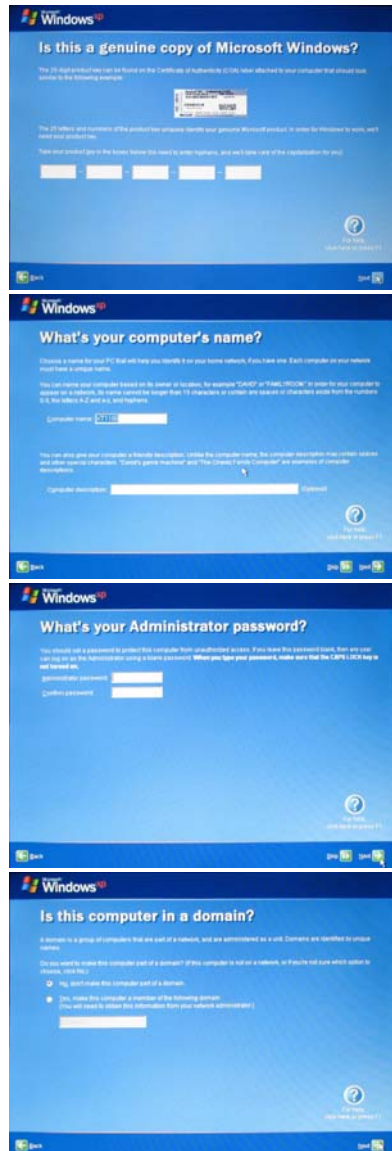

7. Choose whether or not to activate your copy of Windows immediately or at a later date (we recommend you activate the software immediately). Tap **Next** to continue.
8. You can now configure your internet connection. Tap **Yes, help me connect to the Internet** to run the Internet Configuration Wizard. Tap **Next** to continue.
9. Enter the names of other users of your S10A. You can add up to five users. Tap **Next** to continue.
10. Tap **Finish** to complete the setup.



Controlling the S10A

Using the Touch Screen

The S10A is equipped with touch screen technology, for ease of use when you are on the go. Simply tap the screen with your finger to select icons and run applications.

Using the Tap Function

When you tap on the screen with the a pen or stylus, it emulates click functions of a regular mouse.

- To emulate a left click single tap the screen once.
- To emulate a right click tap and hold the screen.
- To emulate a double click, tap the screen twice.

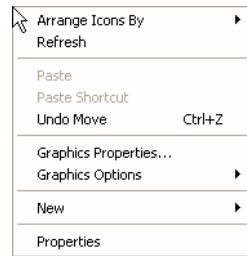

Calibrating the Touch Screen

To calibrate the touch screen, tap **Start > All Programs > PenMount Universal Driver > PenMount Control Panel** to open PenMount Control Panel or tap the pointer device icon in the system tray.



1. Turn on the Advanced Calibration in **Tools > Advanced Calibration**. From PenMount Control Panel, highlight **PenMount 6000 USB** under the **Device** tab. and tap **Configure**. The Device configuration screen opens.

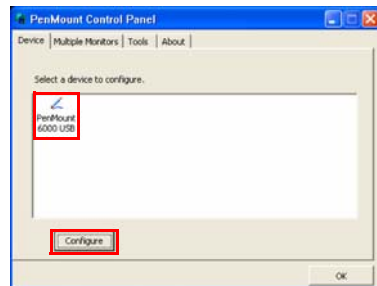

2. Tap the **Calibrate** tab and you will see two options:

- **Standard Calibration:** select this option to start 5 points Standard Calibration.
- **Advanced Calibration:** select this option to use 4, 9, 16, or 25 points to calibrate the screen. Check **Plot calibration data** to enable touch panel linearity comparison graph. The blue lines show linearity before calibration and black lines show linearity after calibration.





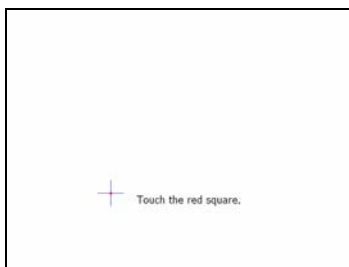



3. Touch the points as displayed onscreen using the pen.

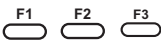

Using the Control Panel Buttons

The control panel buttons are located on the front side of S10A. See below for a description of each button and its function.

Button	Name	Function
	Function	Press to access your favorite programs.
	Keyboard	Press to access the on-screen keyboard.
	Mode	Press to enable/disable mode.
	Enter	Press to emulate the Enter key.
	S1	When mode is enabled, press to decrease brightness setting When mode is disabled, functions as the F4 key; press to access your favorite program.
	S2	When mode is enabled, press to increase brightness setting. When mode is disabled, press to call up barcode function if available. Otherwise, functions as the F5 key.

Using the On-Screen Keyboard



Press  to bring up the on-screen keyboard.



Use your finger to tap and enter letters, numbers and symbols as you would with a regular keyboard. To type capital letters tap the lock icon on the on-screen keyboard.

Configuring the Function Buttons

The F1, F2, F3, S1 (F4) and S2 (F5) can be configured as shortcuts to access your favorite or frequently used programs.

1. Press the function button to which you want to assign a program shortcut to. The function button screen appears.
2. Tap  to locate the program on the hard drive.
3. To remove a configured program, tap .
4. Tap **OK** to save all new settings.

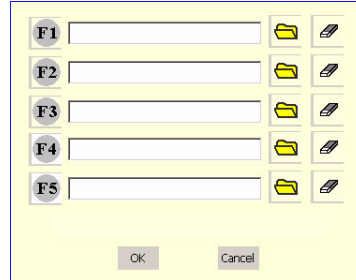





Once you have assigned a function to one of the buttons, you can change it at a later date by tapping on the **Mode** icon on the system tray.





Select **Function Key Setting** from the menu and follow the procedure described above from step 2 to make any changes.

Using the Mode Button

Press  to enable or disable mode.

- When mode is enabled, press  and  to adjust the brightness setting.
- When mode is disabled,  functions as the F4 key while  functions as the F5 key. If a barcode scanner is installed,  functions as the barcode switch key.

Adjusting Screen Brightness

1. Ensure mode is enabled.
2. Press  to decrease brightness, or  to increase brightness.



Adjusting the Volume

1. Tap the **Volume** icon on the system tray.



2. Move the slide to adjust volume.

Wireless Connections

WiFi Connection



WiFi access requires a separate purchase of a service contract with a wireless service provider. Contact a wireless service provider for more information.

The S10A comes pre-loaded with WLAN module, you can send and receive signals to a WiFi network then synchronize files.

A wireless network can be added either when the network is detected or by manually entering settings information. Before doing these steps, determine if authentication information is needed.

1. Right-click the wireless connection icon in the notification area. Select **View Available Wireless Networks** to open **Wireless Connection** screen.

2. Select one of the wireless connections and tap **Connect**.

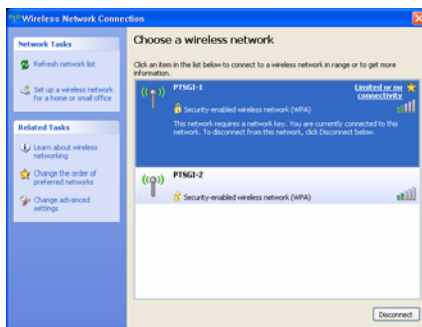

- You are prompted to enter a WEP key for secure access. Contact the network administrator for this key.

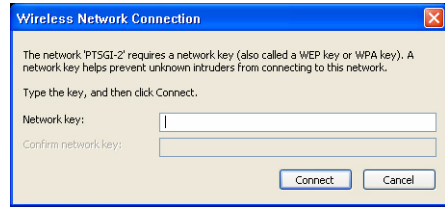

- Enter the required WEP key and reenter the key for confirmation and then tap Connect.
- The wireless connection is negotiated and you see the following screen.

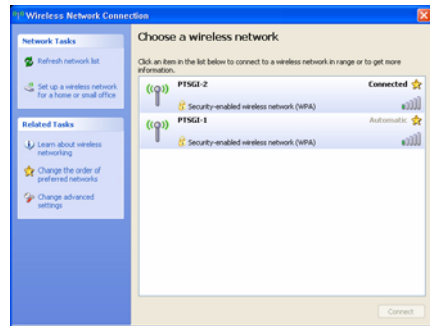

The wireless connection icon in the notification area shows a connected status whenever a wireless connection is present.



Configuring a New Wireless Network

Should you need to configure a set of computers to create a new wireless network, do the following:

1. Tap the wireless icon in the Windows system tray to open the Wireless Network Connection Status screen.
2. Tap **Set up a wireless network for a home or small office**. The Wireless Network Setup Wizard begins.
3. Tap **Next** to continue setup.



4. Enter the name of your network and select whether to assign a secure network key automatically or manually (we recommend you allow the system to do this automatically). Tap **Next** to continue.

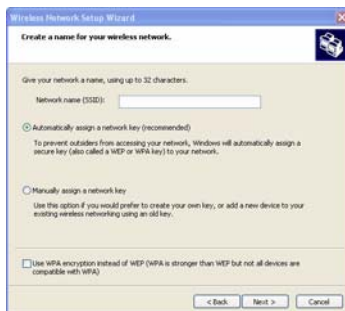

5. Select the method by which you will set up other computers in your network. Choose to use a USB Flash drive to copy and transfer network settings to other computers, or choose to do it manually on each computer in the network (we recommend you use a USB flash drive to transfer settings). Tap



Next to continue. (Skip to step 8 if you decide to configure each computer manually.)

6. Insert your USB flash drive into a free USB slot and select the drive name from the drop-down list. Tap **Next** to continue.



7. All your current network settings are copied to your USB flash disk. Tap **Next** to continue.



8. Setup is complete. Tap **Print Network Settings** to print a list of settings if you are configuring each computer manually. Tap **Finish** to complete the wizard.



9. If you chose to transfer settings to other computers via your USB flash disk, select **Wireless Network Setup Wizard** from the prompt that appears when you insert the disk into other computers. The network settings are transferred automatically.

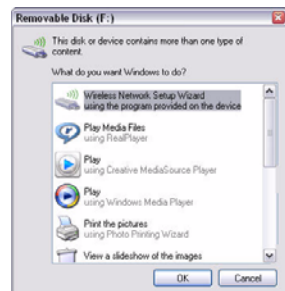

Bluetooth Connections

The S10A comes with built-in Bluetooth functionality that allows you to connect and communicate with other Bluetooth-enabled devices.

Setting Up Bluetooth

Follow these instructions to set up a Bluetooth connection.

1. Tap **Start > Control Panel** and double-tap **Bluetooth Device Properties** to open the **Bluetooth Devices** screen.

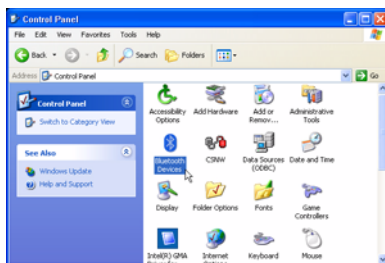

2. Tap **Add** to open the **Add Bluetooth Device Wizard**.



3. Select the **My device is set up and ready to be found** checkbox and tap **Next**.

- The Wizard searches for and displays other Bluetooth devices within range.



- Tap the device you want to connect to and tap **Next**. You are prompted for a passkey.

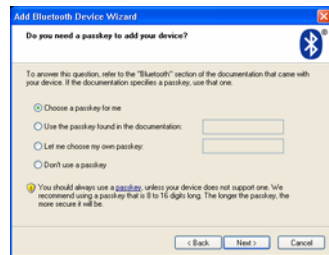

- Select your option and tap **Next**.
- The Wizard attempts to connect with the other device and prompts the other device to input the passkey. If the other device has successfully accepted the passkey, the devices are connected and the Wizard finishes.



Note

It is recommended that you use a passkey to prevent unauthorized access to your S10A.

GPRS Connection (optional)

GPRS function is optional with S10A. It allows you to make 3G connection to the internet. See “Installing a GPRS Module (optional)” on page 11 for installation instruction.



Note

Before setting up GPRS, obtain the access point (AP) from your SIM card's network service provider.

Setting Up GPRS

1. Tap Start > All Programs > Siemens > HSDPA USB Modem > Connection Manager to run the software.

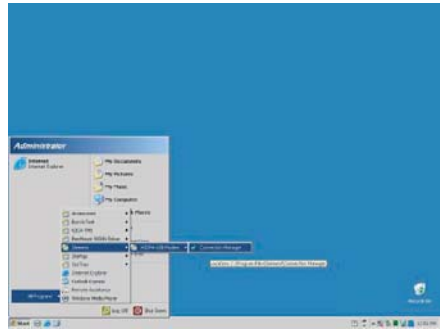

2. On Select Device, select Siemens Wireless Adapter.

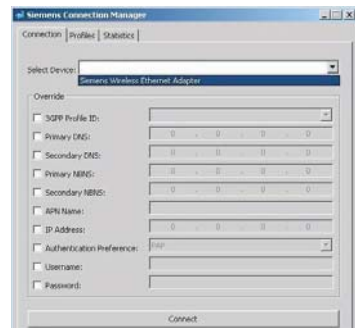

3. Check **APN Name**, then enter the access point name of your network service provider on the space. In this case, "internet" is the AP name.
4. Tap **Connect**.
5. When connected, signal strength is shown on the lower left corner of the Connection Manager window.

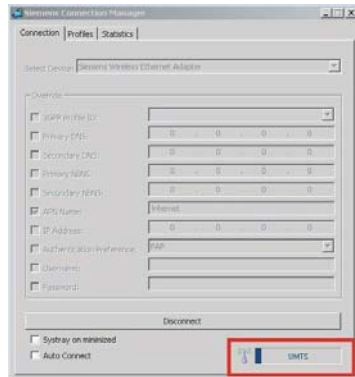
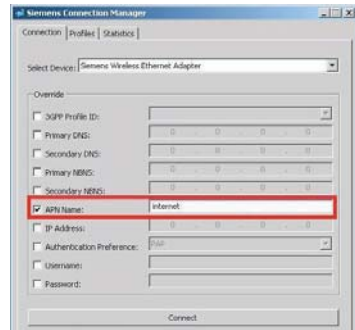

Note

To avoid damage to the SIM card, insert the SIM card before you turn the power on and remove the SIM card after you turn the power off.

GPS Connection (optional)

GPS function comes optional with S10A. It allows you to view your GPS positions. The following illustration demonstrates how the GPS viewer operates. It is only an example.

1. From the Com Port drop down menu tap **COM2** to select COM5 as your com port.
2. From the Baudrate drop down menu tap **9600** to select 4800 as your baudrate.
3. Tap **Open GPS** to start GPS.
4. When satellites are detected, their positions are shown on the map.

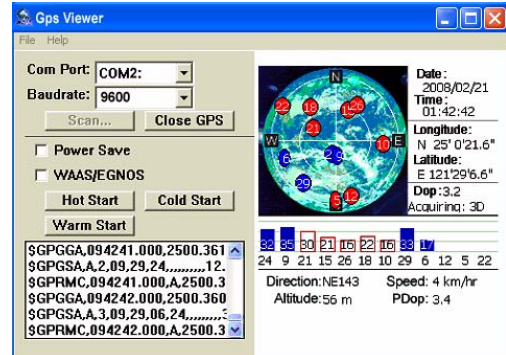
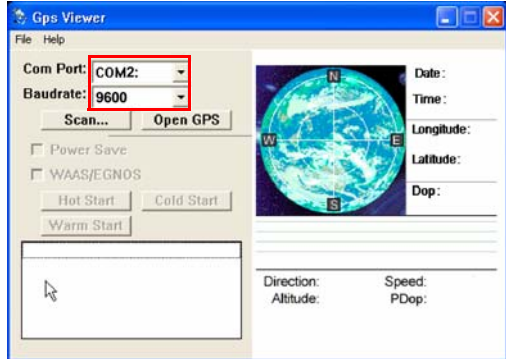

Using the Fingerprint Software

S10A comes with a fingerprint module. Read the following context to install and use the fingerprint software.

Systems Requirements

- Pentium IV or higher or other 100% compatible machines
- Windows 2000 / XP / Vista
- At least 256 MB of RAM or higher

Installation Wizard

1. Click Next.
2. Read the License Agreement. Select "I accept the terms in the license agreement", then click Next.
3. Select the installation path, then click Next.



4. Enter the required settings.
Check "Use Windows Logon",
then click **OK**.



5. To register your fingerprints,
click **Next**.



6. Click the finger you want to register. The selected finger will be highlighted, click **Next** to continue.



7. Place your finger on the sensor as shown on the boxed picture.



8. Continue removing and placing your finger until the **Back** button turns into **Next**, then click **Next**.
9. You can continue to register up to 10 fingers. Click the **Continue** to continue to register another finger.



Note

It is recommended to register at least 2 or more fingers in case your finger gets hurt.

10. Click **Finish** to finish the registration.

The  icon appears on the system tray.



How to Open the Fingerprint Software Menu

There is only one way to open the Menu for Fingerprint software.

Verify Your Fingerprint

1. Click the Fingerprint Software tray icon  and swipe your finger to verify your fingerprint. or press click **Password** to enter the correct password.

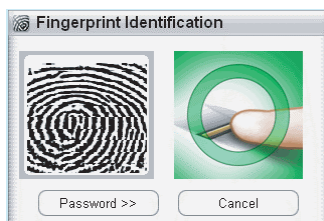
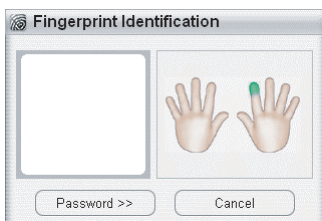

2. Or press **Password** and enter the correct password.

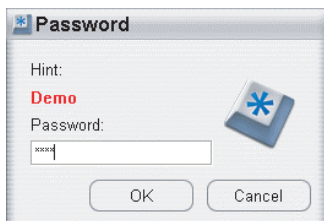
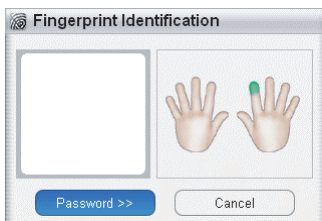

3. If the fingerprint verification succeeds, the menu for fingerprint software appears on screen.

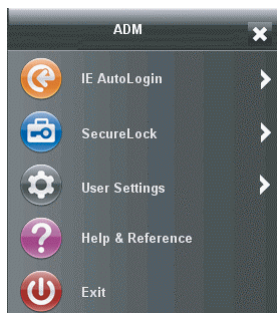

IE Auto Login

IE Auto Login allows you to automate the entry of username and password on a web site. At first, you save your username and/or password for a web site. When you go to the web site, IE Auto Login fills in the dialog boxes automatically after a successful fingerprint or password verification. This application is for Internet Explorer only.

- How to “Save username and password”
- IE Auto Login auto-filling
- Web site login and auto detect
- Auto Login Database Manager
- Sending ID and password automatically

How to “Save Username and Password”

1. Start Internet Explorer and go to the web site for which you want to store your username and/or password.
2. Enter your username and password.

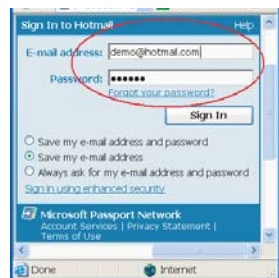
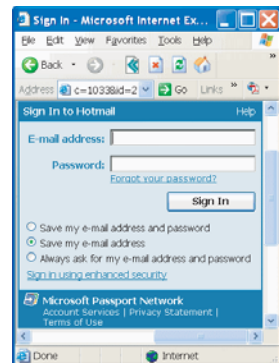

3. Click the  icon on the taskbar of Internet Explorer and choose "Save username and password".

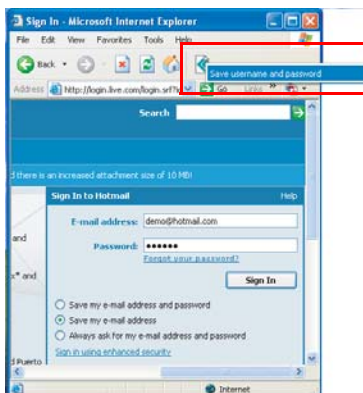

4. Verify your fingerprint or password.

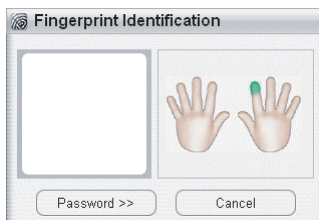

5. After verification succeeds, the username and/or password is saved.

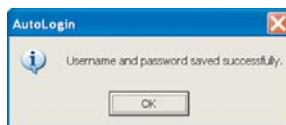
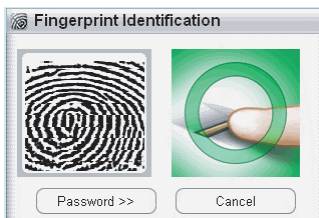

IE Auto Login Auto-Filling

Method 1:

Start Internet Explorer and go to the web site where you have saved your username and/or password.
Verify your fingerprint or password when asked.

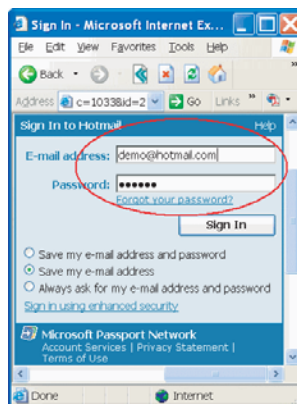
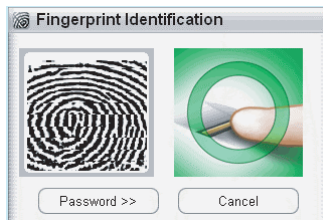
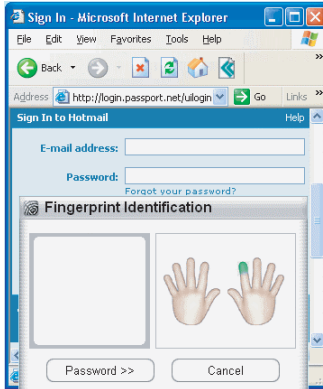

Method 2:

You can also go to the web site directly without starting Internet Explorer via the menu for Fingerprint Access. Click **IE Auto Login** and choose the web site you want to go to. Internet Explorer will automatically start and show the web site you have chosen. And your ID and/or password will automatically be filled in.

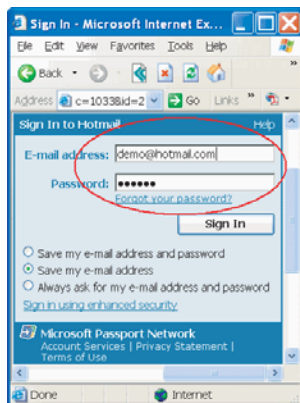
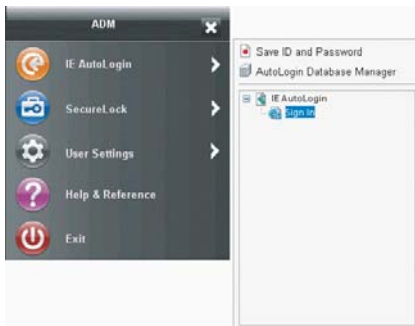

Web Site Login and Auto Detect

Go to the web site where you have login your ID and password, and click login, it will ask "Do you want to save into database?"

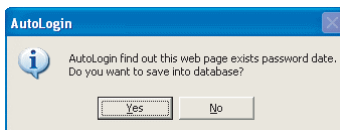

Select **Yes** to save your ID and password, select **No** for not.

If you visit the web site next time, and change the ID and password, auto login will ask you again.

Auto Login Database Manager

You can delete ID and Password, and manage all the URLs you've already registered.

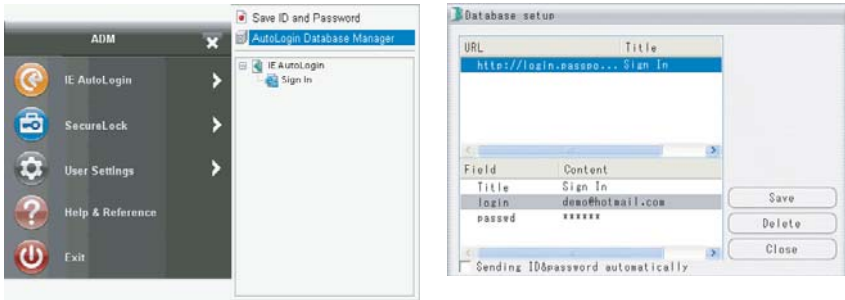

Sending ID and Password Automatically

If you choose the option, when you visit the web site, your ID and password will automatically be filled and auto login will be done.

Secure Lock

Secure Lock is installed in the Virtual Disk of Fingerprint Access.

- Secure Lock "Lock" / "Unlock"
- Resize

Secure Lock "Lock" / "Unlock Drive"

Open "Menu for Fingerprint Software > SecureLock > Unlock Drive".

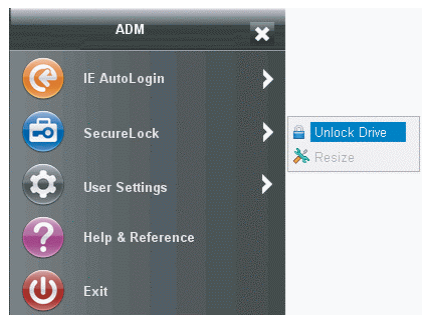

Secure Lock “Unlock Drive”:

1. Go to “Secure Lock” and select “Unlock Drive”.
2. When the Secure Lock is on the condition of “Unlock”, you can see the Virtual Disk **Encrypt Disk (P:)** in the Windows Explorer. Meanwhile, it acts as a virtual hard drive.

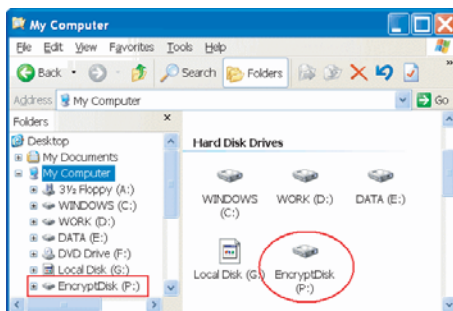

Secure Lock “Lock”:

1. Go to “Secure Lock” and select “Lock”.
2. When the Secure Lock is on the condition of “Unmount”, the Virtual Disk in the Windows Explorer will disappear and cannot be used.

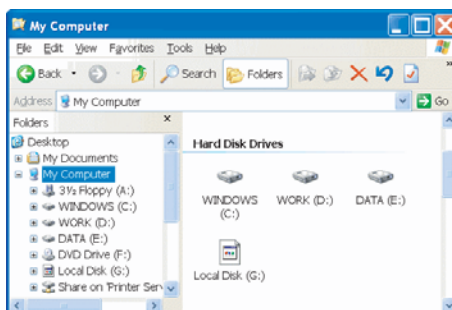

Resize

- The Secure Lock has to be on the condition of “Unlock”.
- The maximum is the available storage space shown on the interface.

Option

1. Open “Menu for Fingerprint Software”.
2. Select and click **Resize**, and you can change the capacity of the Virtual Disk.

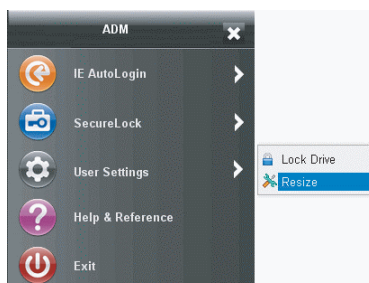

3. In the Resize window, there are two ways to change the capacity of the Virtual Disk.

- One is to drag the scroll bar to the left/right to decide the size.
- Another is to enter the capacity you would like to change.



4. After completing capacity change, a message box will pop up to indicate it is completed.



Fingerprint Security

- Folder Encryption / Decryption
- File Encryption / Decryption

Folder Security

Folder Encryption:

Encrypted folders enable fingerprint security to all files within a folder.

1. Point the cursor to the folder you wish to encrypt and right-click. Choose "Encrypt Folder" from the menu,
2. When authentication is successful, the folder (and files inside) will be encrypted. Files inside this folder will also have a lock on their icons.

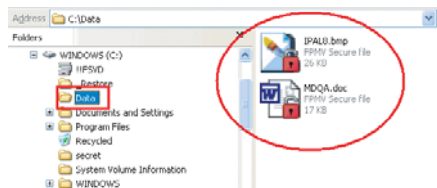
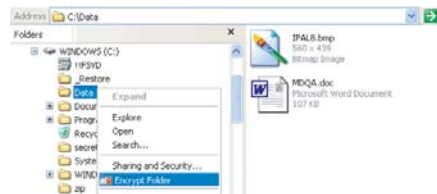

- Moving files into an encrypted folder will cause those files to be automatically encrypted. When removing files from an encrypted folder to a non-encrypted area, “Fingerprint Authentication” dialog will ask you for your fingerprint, and the file will be decrypted.

Folder Decryption:

To decrypt encrypted files.

- Right-click on the encrypted folder, and choose “Decrypt Folder” from the menu.

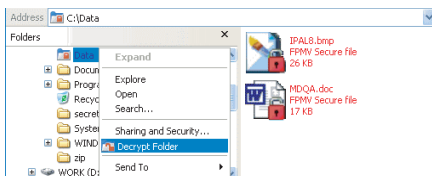

- “Fingerprint Identification” dialog will ask you for your fingerprint.

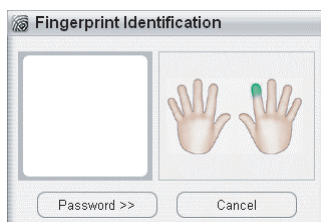

- When authentication is successful, the folder will be decrypted.

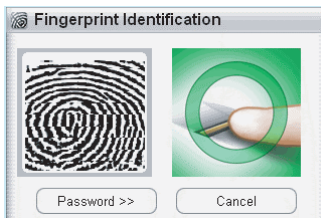

- The icon of the decrypted folder will return to its normal appearance.

Files inside the folder will also be decrypted and the icons will have no locks.

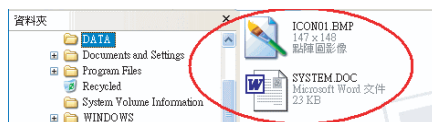

File Security

File Encryption:

Your encrypted files can only be accessed by fingerprint (or password).

1. Point the cursor to the file you want to encrypt and right-click. Choose “Encrypt File” from the menu.
2. When authentication is successful, the file will be encrypted. Encrypted files will have a lock on their icons.

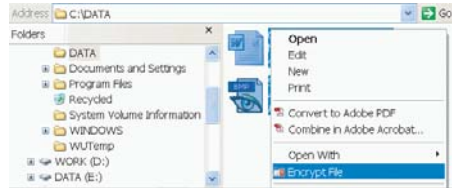

File Decryption:

To decrypt encrypted files.

1. Point the cursor to the file you want to decrypt and right-click. Choose “Decrypt File” from the menu.
2. “Fingerprint Authentication” dialog will ask you for your fingerprint verification. (This process can only be executed by typing in your password.)

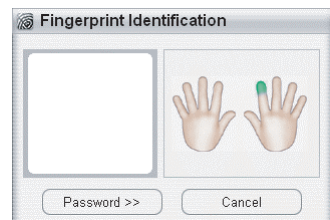
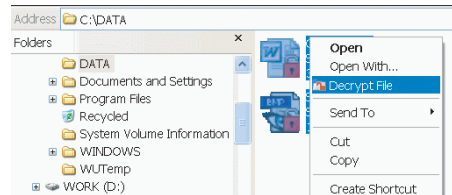

3. When authentication is successful, the file will be decrypted.

4. The icon of the decrypted file will have no lock and will go back to its normal appearance.

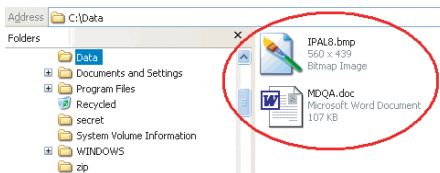
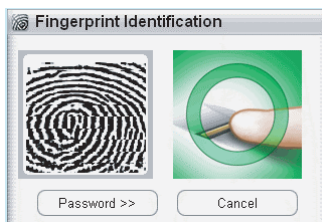

User Settings

Open "Menu for Fingerprint Software > User Settings".

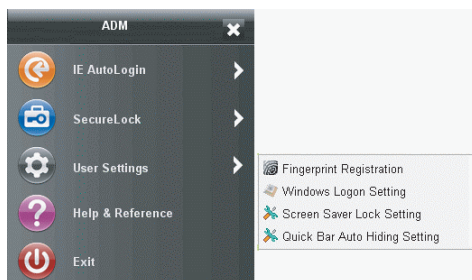

In "User Settings" dialog, you can set:

- Fingerprint Registration
- Windows Logon Setting
- Screen Saver Lock Setting
- Quick Bar Auto Hiding Setting

Fingerprint Registration

1. Right-click on the tray icon  and select **Fingerprint Registration**.
2. In the “Fingerprint Identification” windows, there are two ways to verify your fingerprint.

Method 1.

- **Finger Identification:** Verify your previously registered fingerprint. The green fingers show which fingers have been registered.

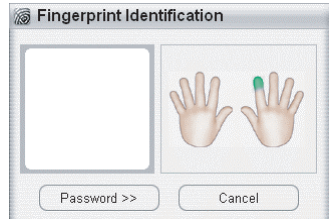

Method 2.

- **Password:** Click the “Password” button and enter your password if you want to use it instead of your fingerprint.

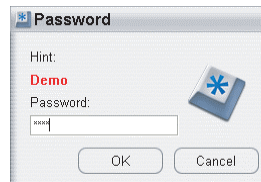
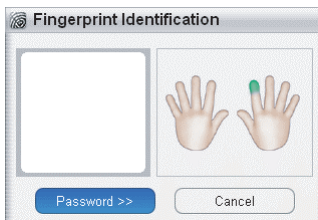

Fingerprint Registration Wizard will start. And you may register or delete your registered fingers.

- Green: Already registered finger(s).
- Blue: Non-registered finger(s).

Note: This product may authenticate the fingerprint, which is other than what is registered due to the similarity in shape of the fingerprint between them.



Windows Logon Setting

1. Open "Menu for Fingerprint Software > User Settings".



2. Set "Windows Logon Setting".



3. Restart Windows, you must swipe your finger to logon.

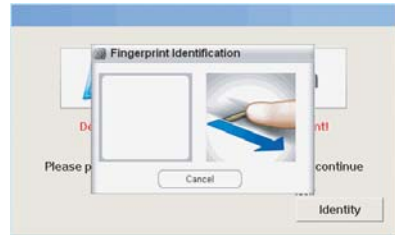

4. If the fingerprint verification succeeds, you can logon Windows.

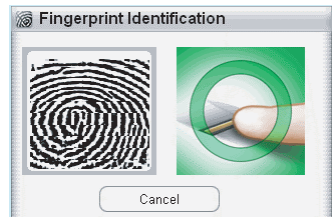

Screen Saver Lock Setting

Introduction

When the “Screen Saver Lock” starts, only an authorized person can unlock the Screen Saver by verifying his/her fingerprint or password. The Screen Saver Lock makes your PC more secure.

The main function of “Screen Saver Lock” is to disable the keyboard and the mouse.

1. Open “Menu for Fingerprint Software > User Settings > Screen Saver Lock Setting” .



2. It will open the “Screen Saver Lock” dialog.

After you have set the Screen Saver Lock, the computer will be in protection.



How to Release “Screen Saver Lock”

When you hit any key in the keyboard or move your mouse, the “Finger Identification” dialog will appear. Verify your fingerprint or password, and the Screen Saver will be released.

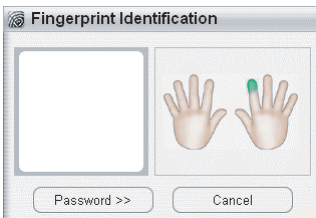

Quick Bar Auto Hiding Setting

1. Open "Menu for Fingerprint Software > User Settings > Quick Bar Auto Hiding Setting".

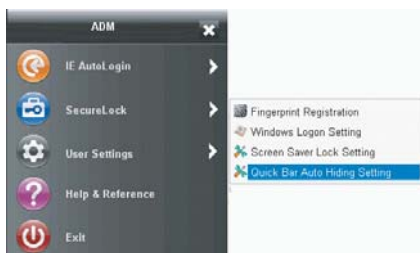

- **Never hide Quick Bar:** If you don't want to hide the Quick Bar, please check this option.
- **Second:** You can set the auto hiding time here. (Example: 5 seconds)

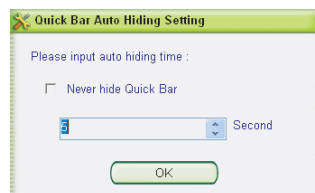
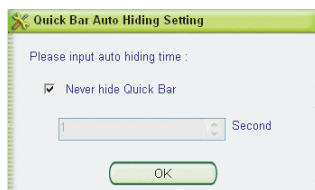

Add Another User Account's Fingerprint(s)

1. Login another user account through original password entered.
2. Click the fingerprint tray icon .
3. New fingerprint enroll will start.

Uninstall

There are two ways you can uninstall the software.

- Click **Windows Start > All Programs > Fingerprint Software > Uninstall**.
- Click **Windows Start > Control Panel > Add or Remove Programs**, choose “Remove Fingerprint Application” then click “Change/Remove”.

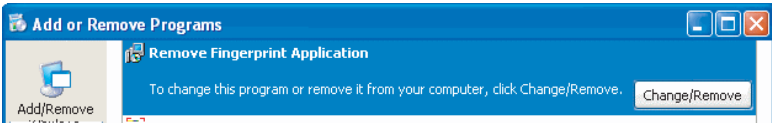

The “Uninstallation Wizard” will start.

1. It will remove all of the files in the Fingerprint Software folder, click **OK**.

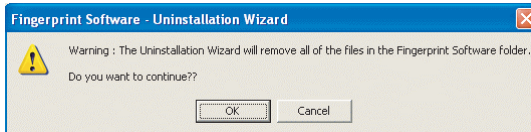

2. Verify your fingerprint.

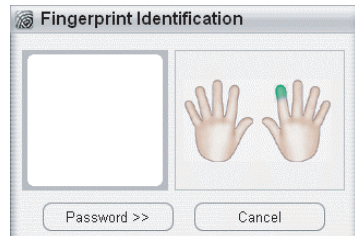

Swipe the correct fingerprint.

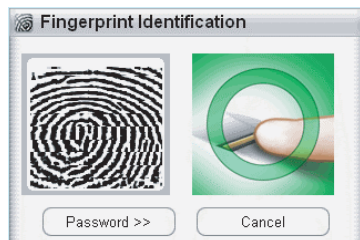

3. "Delete Fingerprint Software" and the following messages will appear. Click **Yes** to complete the uninstallation.

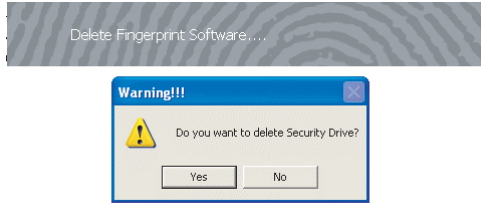

Advanced Settings

Configuring Touch Screen Function

Tap the pointer device icon in the system tray then select the Tools tab > or tap Start > All Programs > PenMount Universal Driver > PenMount Control Panel to access PenMount Control Panel.

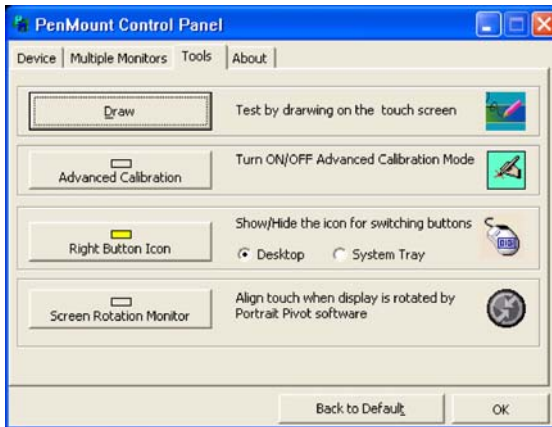

Tap the tabs at the top of the screen to access the settings screens. The contents in each tab page may vary based upon the version of the operating system you are using.

Checking Battery Status

As it is likely you will be using your S10A when out and about, it is important that you monitor the battery status regularly, to ensure you do not run out of power at a critical moment.

Double tap on the Power icon on the system tray to view detailed information.



The battery screen appears:

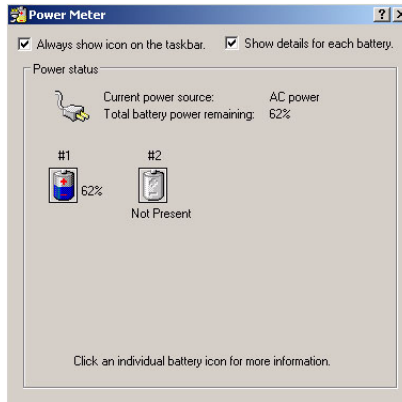

Tap on the battery icon for more detailed information.



#1 battery indicates the status of the internal battery.

#2 battery indicates the status of the external battery. See "External Battery" on page 68.

Power Options

You can configure specific power options to best suit your needs and to get the most out of your battery. Tap on the **Power** icon in the system tray to view the **power options** menu. See below for a description of the settings for each power option.

	Monitor turns off after	Hard disks turn off after	System goes into standby mode after	System goes into hibernate mode after
Home/Office Desk	5 minutes	10 minutes	5 minutes	20 minutes
Portable/Laptop	Never	Never	Never	
Presentation	Never	5 minutes	15 minutes	2 hours
Always On	15 minutes	30 minutes	Never	Never
Minimal Power Management	5 minutes	15 minutes	5 minutes	3 hours
Max Battery	1 minute	3 minutes	2 minutes	1 hour



You can also access further power options through the Control Panel. Click **Start > Control Panel > Power Options**.

Maintenance

Maintaining the Battery

- Do not expose heat or attempt to disassemble the battery, and do not place the battery in water or in a fire.
- Do not subject the battery to strong impact, such as a blow from a hammer, or stepping on or dropping it.
- Do not puncture or disassemble the battery.
- Do not attempt to open or service the battery.
- Replace only with batteries designed specifically for this product.
- Keep the battery out of reach of children.
- Dispose of used batteries according to local regulations.

Maintaining the LCD Display

- Do not scratch the surface of the screen with any hard objects.
- Do not spray liquid directly on the screen or allow excess liquid to drip down inside the device.
- Do not place anything, such as food and drink, on the screen at any time to prevent damage to the screen.
- Clean the LCD display only with a soft cloth dampened with denatured alcohol or a proprietary LCD screen cleaner.

Cleaning the S10A

1. Turn off the S10A and unplug the power cord.
2. Wipe the screen and exterior with a soft, damp cloth moistened only with water. Do not use liquid or aerosol cleaners on the screen, as these will discolor the finish and damage the screen.

Troubleshooting

Recovering from a System Crash (Windows XP Professional Embedded)

In the unlikely event that your S10A should crash, do the following to re-boot your system if you are using Windows XP Professional Embedded.

1. Connect a USB keyboard to the USB port on your S10A.

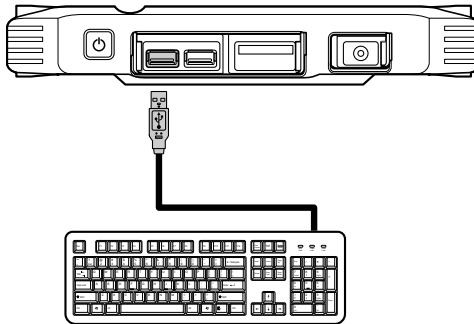

2. Press the power button to turn on the S10A. During boot-up, **PRESS UP KEY TO RUN RESTORE...** is displayed. Press the up arrow button.
3. The recovery software screen appears with the message **'Are you sure you want to recover the partition now?'**. Press **Enter** to confirm. The recovery operation starts.

Should you have any further problems, contact technical support for assistance.

Recovering from a System Crash (Windows XP Embedded)



Note

If you are using an SD card for data storage, your S10A will follow the recovery procedures to re-boot your system.

If you are using Windows XP Embedded, follow these steps to perform a recovery procedure using a USB flash drive should your system crash:

1. Download the **FORMATUPD.EXE** file to your local drive (C:\).
2. Connect a USB flash drive to your computer.



3. Click **Start > Run** and type **cmd** in the command box.
4. Type **cd** and press **Enter**.
5. Type **FORMATUFD F: /y**
6. Copy the files from the **Windows XPE Recovery** folder on your local drive to the USB flash drive.
7. Connect the USB flash drive and a keyboard to your S10A and turn on the computer.
8. Press the **Del** key repeatedly during boot up to enter the BIOS screen.
9. Highlight **Advanced BIOS Features** and press **Enter**.
10. Highlight **Hard Disk Boot Priority** and press **Enter**.
11. Highlight your USB flash drive from the list and press **+** to move it up until it is at the top of the list.
12. Press **F10** to exit the screen.

```
C:\>formatufd F: /y
Microsoft® UFD Preparation Tool for Windows Preinstallation Environment
Copyright © Microsoft Corporation 2004. All rights reserved.
Success: The media was successfully prepared for hosting UiaPF.
Now validating results ...
Success: This media is properly formatted to host UiaPF.
C:\>
```

13. Highlight **Save & Exit Setup** and press **Enter**.
 14. Press **Y** to save and exit when the confirmation message appears.



15. The system will now enter recovery mode. Click **OK** twice to continue.



16. Once the process is complete, click **Quit**, remove the USB flash drive and the system will restart automatically.



Appendix

Specifications

Feature	Description
Operating System	Windows XP Embedded/ Windows XP Professional Embedded Windows Vista Basic
Processor	Intel ATOM Z530 1.6G / Z510 1.1G
Chipset	US15W
Memory	One SO-DIMM DDRI 533 support up to 2GB
Storage	Compact Flash (CF) Memory Card (4G/8G)
Display	10.4" XGA TFT LCD
Touch Panel	4-wire resistive touch panel
Application Button	One Power button One software keyboard button One Mode button One Enter button Five Function programmable buttons for quick selection of applications
Communication	802.11b/g/n WLAN (miniPCI-E) module Bluetooth class 2, v2.0+EDR Modem or Internal GPRS HSDPA (optional) GPS module (optional)
Audio System	Realtek ALC662
Main Battery	Rechargeable Li-ion smart battery, 1900mA, 3S1P
Power Adapter	Universal AC 100V~240V, 50~60Hz input; 19V, 3.16A output, 60W

Feature	Description
LED Status Indicators	Power LED: Off: Power off Solid green: Lit when charging in power off mode, off when charging is complete Blinking green: Power on, battery is charging in power on mode Solid yellow: Power on, battery low Blinking yellow: Power on, battery critically low HDD LED: Green when HDD is being accessed WLAN LED: Off: No RF signal / No LAN connection Solid Green: WLAN activated Blinking Green: TX/RX transmission
Other Components	CCD Camera 2M Fingerprint scanner TMP 1.2
I/O Port	Two USB 2.0 host connector One RS-232 One VGA output One 4-in-1 card reader (external memory card) One PCMCIA slot Card Slot (optional) One stereo headphone jack One microphone jack One DC-In jack One docking connector
Physical	264 x 213 x 18mm Approx. 1.2Kg
Environment	Operating Temperature: 0°C to 40°C Storage Temperature -20°C to 60°C Operating Humidity 5% ~ 95%
Rugged Rating	IP54 3ft drop

Feature	Description
Certification	CE, FCC
Optional Device / Accessories	1D / 2D Barcode Scanner MSR 1+2+3 track RFID 13.56M GPS Module GPRS Desk Docking Hand Strap VESA Mount External Battery Holster

Optional Accessories

External Battery

You can use an external battery to extend the power of your tablet PC.

Battery specification: 3800mA 3S2P

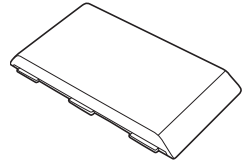

Installing the External Battery

1. Remove the external battery contacts cover from the tablet PC (A).
2. Insert the contacts cover on the external battery (B).
3. Align and insert the battery on the tablet PC (C).
4. Lock to secure the battery in place (D).

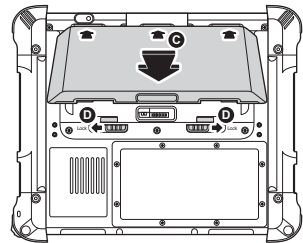
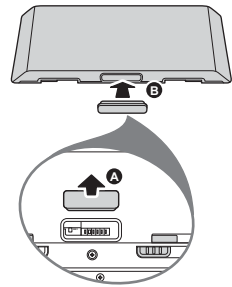

Removing the External Battery

Repeat the above steps in reverse order to remove the battery.

Tablet PC Docking

You can use the docking stand to dock the tablet PC when you are at your home or on your office desk. When docked, you can charge both the internal and external batteries or transfer data from your tablet PC to another PC.

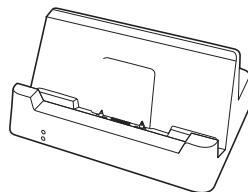

Attach the S10A to the docking stand as shown.

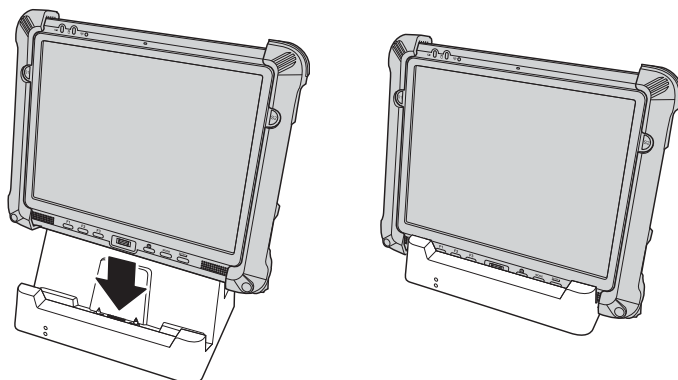

To charge the external battery, attach the battery to the docking stand as shown below.

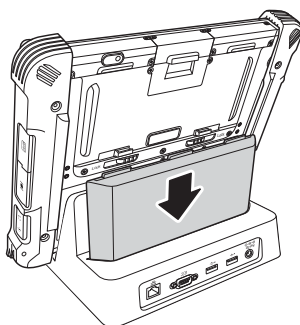
**Note**

The external battery can also be charged when installed on the tablet PC.

Docking Connectors

See below for the rear view of the docking and a description of all ports and connectors.

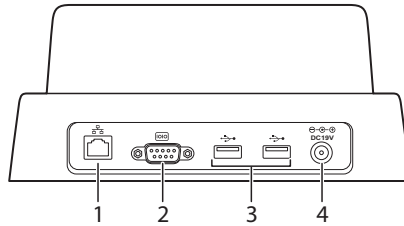

No.	Component	Function
1	LAN port	Connect an RJ-45 cable to access LAN connection.
2	Serial port	Connect a serial cable to connect to another PC.
3	USB ports	Connect USB connectors to transfer data.
4	DC-IN	Connect the AC adapter to charge the battery.

Connecting Power to the Docking

Connect the AC power adapter to the docking and the mains as shown below.

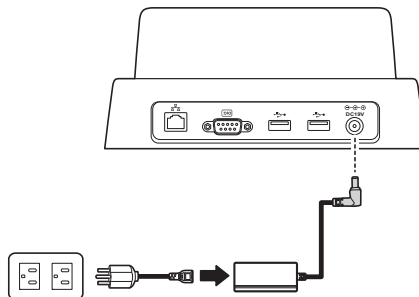

Docking Specifications

Feature	Description
Product Name	S10A Tablet PC Docking
Model Number	S10AC
External I/O Interfaces	One LAN port One RS-232 Two USB 2.0 host connectors One DC-in
Power Adapter	Universal AC 90V ~ 265V, 47~63Hz input; 19V, 3.16A output
Physical Size	230 x 154 x 252 mm
Environment	Operating Temperature -20°C to 60°C Storage Temperature -40°C to 70°C Operating Humidity 10% ~ 95%
Certification	CE, FCC

Adjustable Stand

You can use the adjustable stand to provide desk support when you are at home or in your office.

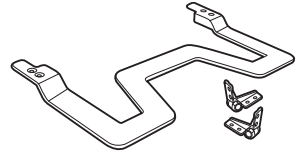

Attaching the Adjustable Stand

1. Fasten four screws to attach the two stand brackets to your Tablet PC.
2. Fasten the four screws to attach the stand to the brackets.
3. Pull to adjust the stand to desirable angle.

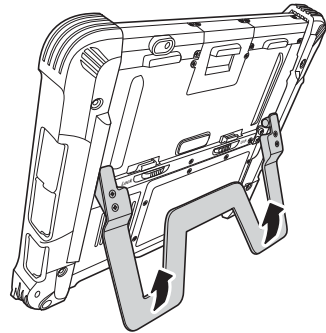
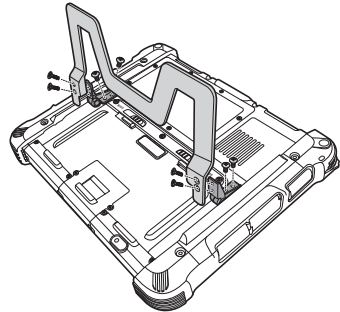

Handstrap and Shoulder Strap

A detachable handstrap and shoulder strap are provided to carry your Tablet PC securely and safely. You can use the supplied handstrap and shoulder strap separately or together to carry the S10A when you are outside your home or office.

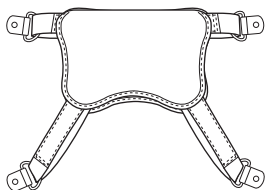

Handstrap

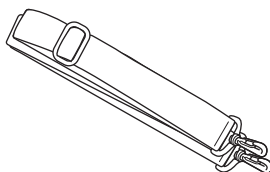

Shoulder Strap

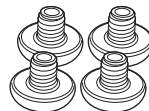

Screws

When using the handstrap and shoulder strap separately:

- Attach the handstrap to the rear of your tablet PC using the four short screws.

Ensure the straps and the flap are securely attached.

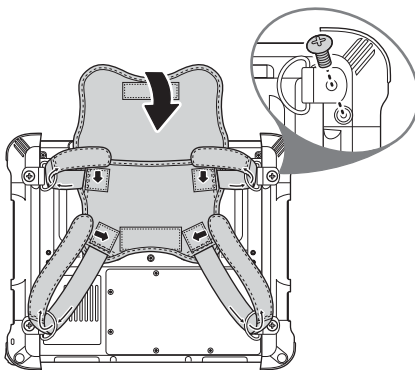

The handstrap makes it easy to carry the device on one hand.

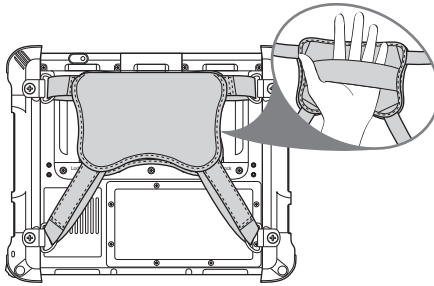

- Attach the shoulder strap to the rear of your tablet PC using two screws as shown.

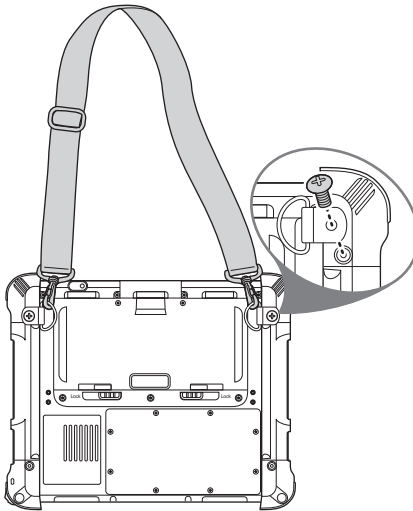

When using the handstrap and shoulder strap together:

- Attach the handstrap to the rear of your tablet PC using the four screws. Then hook the shoulder strap as shown.

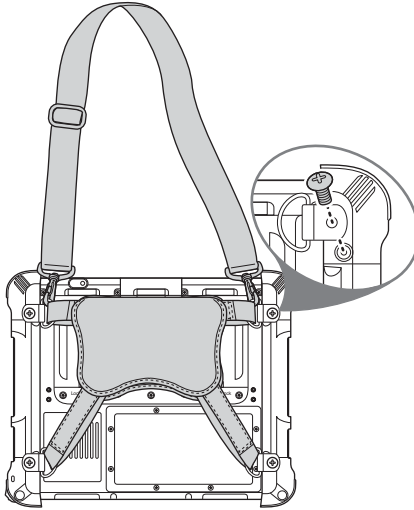

Vesa Mount

Vesa mount can be used with a variety of alternate mounting solutions such as wall mounts.

- Install the vesa mount by screwing on the screws as shown.

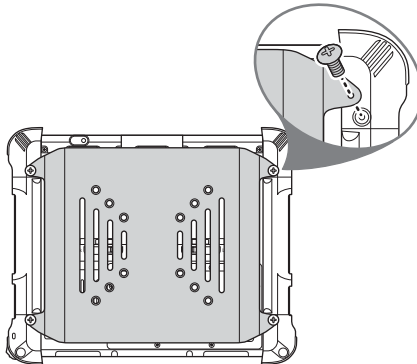

▶ RF Exposure Information (SAR)

This device meets the government's requirements for exposure to radio waves.

This device is designed and manufactured not to exceed the emission limits for exposure to radio frequency (RF) energy set by the Federal Communications Commission of the U.S. Government.

The exposure standard employs a unit of measurement known as the Specific Absorption Rate, or SAR. The SAR limit set by the FCC is 1.6W/kg. Tests for SAR are conducted using standard operating positions accepted by the FCC with the EUT transmitting at the specified power level in different channels.

The highest SAR value for the device as reported to the FCC is **0.035** W/kg when placed next to the body.

The FCC has granted an Equipment Authorization for this device with all reported SAR levels evaluated as in compliance with the FCC RF exposure guidelines. SAR information on this device is on file with the FCC and can be found under the Display Grant section of www.fcc.gov/oet/ea/fccid after searching on FCC ID: **M82-S10AB**.

This device is compliance with SAR for general population /uncontrolled exposure limits in ANSI/IEEE C95.1-1999 and had been tested in accordance with the measurement methods and procedures specified in OET Bulletin 65 Supplement C.