

User Manual

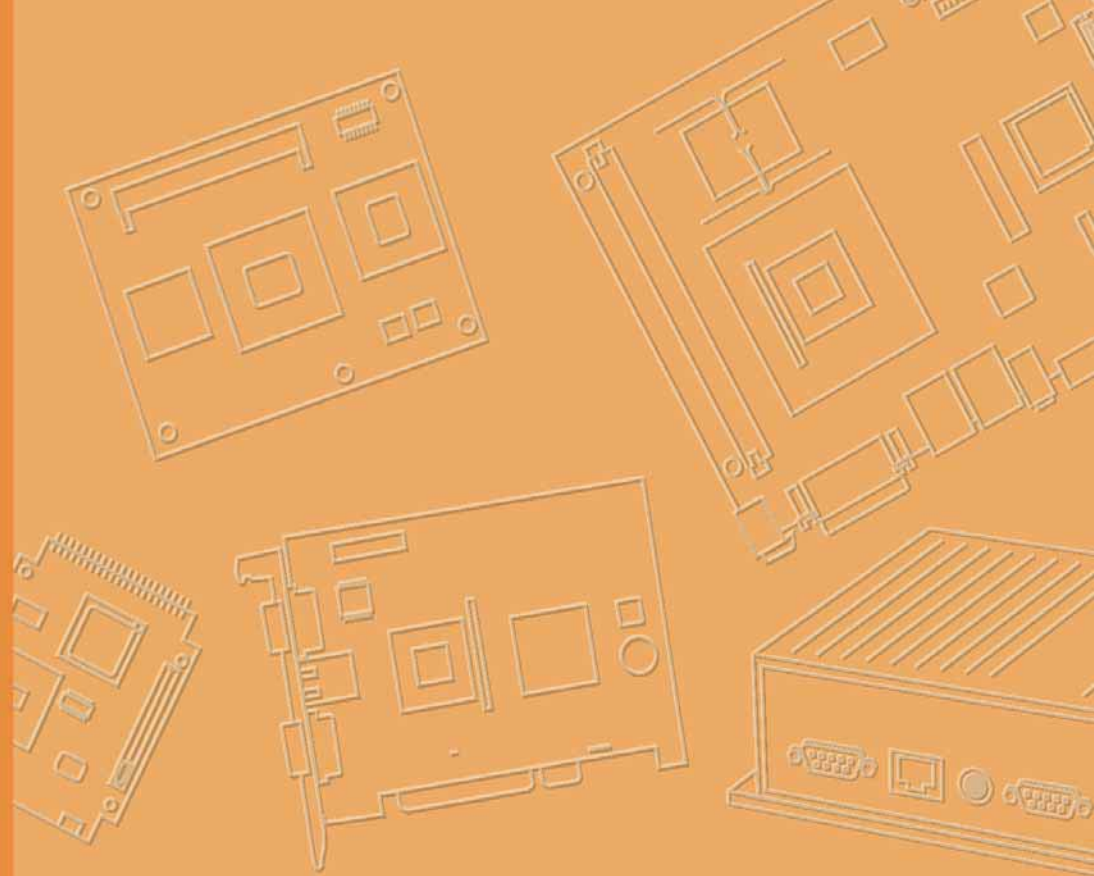

# TREK-688

Computer

**ADVANTECH**

*Enabling an Intelligent Planet*

---

## Copyright

The documentation and the software included with this product are copyrighted 2015 by Advantech Co., Ltd. All rights are reserved. Advantech Co., Ltd. reserves the right to make improvements in the products described in this manual at any time without notice. No part of this manual may be reproduced, copied, translated or transmitted in any form or by any means without the prior written permission of Advantech Co., Ltd. Information provided in this manual is intended to be accurate and reliable. However, Advantech Co., Ltd. assumes no responsibility for its use, nor for any infringements of the rights of third parties, which may result from its use.

## Acknowledgements

Intel® and Pentium are trademarks of Intel Corporation.

Microsoft Windows® and MS-DOS are registered trademarks of Microsoft Corp.

All other product names or trademarks are properties of their respective owners.

## Product Warranty (2 years)

Advantech warrants to you, the original purchaser, that each of its products will be free from defects in materials and workmanship for two years from the date of purchase.

This warranty does not apply to any products which have been repaired or altered by persons other than repair personnel authorized by Advantech, or which have been subject to misuse, abuse, accident or improper installation. Advantech assumes no liability under the terms of this warranty as a consequence of such events.

Because of Advantech's high quality-control standards and rigorous testing, most of our customers never need to use our repair service. If an Advantech product is defective, it will be repaired or replaced at no charge during the warranty period. For out-of-warranty repairs, you will be billed according to the cost of replacement materials, service time and freight. Please consult your dealer for more details.

If you think you have a defective product, follow these steps:

1. Collect all the information about the problem encountered. (For example, CPU speed, Advantech products used, other hardware and software used, etc.) Note anything abnormal and list any onscreen messages you get when the problem occurs.
2. Call your dealer and describe the problem. Please have your manual, product, and any helpful information readily available.
3. If your product is diagnosed as defective, obtain an RMA (return merchandise authorization) number from your dealer. This allows us to process your return more quickly.
4. Carefully pack the defective product, a fully-completed Repair and Replacement Order Card and a photocopy proof of purchase date (such as your sales receipt) in a shippable container. A product returned without proof of the purchase date is not eligible for warranty service.
5. Write the RMA number visibly on the outside of the package and ship it prepaid to your dealer.

Part No. 2008T68800

Printed in Taiwan

Edition 1

November 2015

# Declaration of Conformity

## CE

This product has passed the CE test for environmental specifications. Test conditions for passing included the equipment being operated within an industrial enclosure. In order to protect the product from being damaged by ESD (Electrostatic Discharge) and EMI leakage, we strongly recommend the use of CE-compliant industrial enclosure products.

## FCC Class B

Note: This equipment has been tested and found to comply with the limits for a Class B digital device, pursuant to part 15 of the FCC Rules. These limits are designed to provide reasonable protection against harmful interference in a residential installation. This equipment generates, uses and can radiate radio frequency energy and, if not installed and used in accordance with the instructions, may cause harmful interference to radio communications. However, there is no guarantee that interference will not occur in a particular installation. If this equipment does cause harmful interference to radio or television reception, which can be determined by turning the equipment off and on, the user is encouraged to try to correct the interference by one or more of the following measures:

Reorient or relocate the receiving antenna (cable over 20 CM)

Increase the separation between the equipment and receiver.

Connect the equipment into an outlet on a circuit different from that to which the receiver is connected.

Consult the dealer or an experienced radio/TV technician for help.

## FCC Caution :

Any changes or modifications not expressly approved by the party responsible for compliance could void the user's authority to operate this equipment.

## FCC RF Radiation Exposure Statement :

1. This Transmitter must not be co-located or operating in conjunction with any other antenna or transmitter.

2. This equipment complies with FCC RF radiation exposure limits set forth for an uncontrolled environment.

This equipment should be installed and operated with a minimum distance of 20 centimeters between the radiator and your body.

According to FCC 15.407(e), the device is intended to operate in the frequency band of 5.15GHz to 5.25GHz under all conditions of normal operation. Normal operation of this device is restricted to indoor use only to reduce any potential for harmful interference to co-channel MSS operations.

# Technical Support and Assistance

1. Visit the Advantech web site at <http://support.advantech.com> where you can find the latest information about the product.
2. Contact your distributor, sales representative, or Advantech's customer service center for technical support if you need additional assistance. Please have the following information ready before you call:
  - Product name and serial number
  - Description of your peripheral attachments
  - Description of your software (operating system, version, application software,

etc.)

- A complete description of the problem
- The exact wording of any error messages

# Warnings, Cautions and Notes

**Warning!** Warnings indicate conditions, which if not observed, can cause personal



*injury!*

**Caution!** Cautions are included to help you avoid damaging hardware or losing data. e.g.



*There is a danger of a new battery exploding if it is incorrectly installed. Do not attempt to recharge, force open, or heat the battery. Replace the battery only with the same or equivalent type recommended by the manufacturer. Discard used batteries according to the manufacturer's instructions.*

**Note!** Notes provide optional additional information.



## Document Feedback

To assist us in making improvements to this manual, we would welcome comments and constructive criticism. Please send all such - in writing to: [support@advan-tech.com](mailto:support@advan-tech.com)

## Packing List

Before setting up the system, check that the items listed below are included and in good condition. If any item does not accord with the table, please contact your dealer immediately.

Part number	Description	Q`ty
	TREK-688 Computing Box	1
1750007927-01	2 in 1 (WWAN+GPS) Antenna	1
1750007928-01	WWAN Antenna	1
1750007564-01	WiFi + BT(2.4/5GHz) Antenna	1
1700023051-01	VIO Cable	1
1700023050-01	GIO Cable	1
1700022702-01	Video Cable	2
1700019031	Power cable (2M)	1
1700020123	USB Cable	1
9680001742	HDD/SSD Tray key lock	1

# Ordering Information

P/N	Description
TREK-688-7LWB7PA0E	i7-4650U/LTE/HSPA+(EU)/GPS/WLAN/BT/SSD/Win7Pro
TREK-688-7LWB7PBOE	i7-4650U/LTE/HSPA+(US)/GPS/WLAN/BT/SSD/Win7Pro

## Safety Instructions

1. Read these safety instructions carefully.
2. Keep this User Manual for later reference.
3. Disconnect this equipment from any AC outlet before cleaning. Use a damp cloth. Do not use liquid or spray detergents for cleaning.
4. For plug-in equipment, the power outlet socket must be located near the equipment and must be easily accessible.
5. Keep this equipment away from humidity.
6. Put this equipment on a reliable surface during installation. Dropping it or letting it fall may cause damage.
7. Do not leave this equipment in an environment unconditioned where the storage temperature under  $-40^{\circ}\text{C}$  ( $-40^{\circ}\text{F}$ ) or above  $80^{\circ}\text{C}$  ( $176^{\circ}\text{F}$ ), it may damage the equipment. Operating temperature:  $-30^{\circ}\text{C}$   $\sim$   $55^{\circ}\text{C}$ .
8. The openings on the enclosure are for air convection. Protect the equipment from overheating. **DO NOT COVER THE OPENINGS.**
9. Make sure the voltage of the power source is correct before connecting the equipment to the power outlet.
10. Position the power cord so that people cannot step on it. Do not place anything over the power cord. The voltage and current rating of the cord should be greater than the voltage and current rating marked on the product.
11. All cautions and warnings on the equipment should be noted.
12. If the equipment is not used for a long time, disconnect it from the power source to avoid damage by transient overvoltage.
13. Never pour any liquid into an opening. This may cause fire or electrical shock.
14. Never open the equipment. For safety reasons, the equipment should be opened only by qualified service personnel.
15. If one of the following situations arises, get the equipment checked by service personnel:
  - „ The power cord or plug is damaged.
  - „ Liquid has penetrated into the equipment.
  - „ The equipment has been exposed to moisture.
  - „ The equipment does not work well, or you cannot get it to work according to the user's manual.
  - „ The equipment has been dropped and damaged.
  - „ The equipment has obvious signs of breakage.
16. **CAUTION:** The computer is provided with a battery-powered real-time clock circuit. There is a danger of explosion if battery is incorrectly replaced. Replace

only with same or equivalent type recommended by the manufacture. Discard used batteries according to the manufacturers instructions.

17. THE COMPUTER IS PROVIDED WITH CD DRIVES COMPLY WITH APPROPRIATE SAFETY STANDARDS INCLUDING IEC 60825.

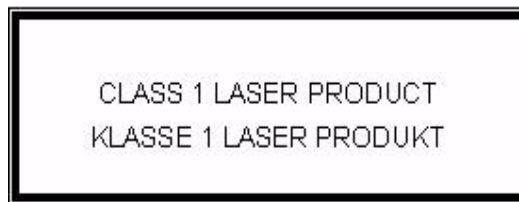

18. This device complies with Part 15 of the FCC rules. Operation is subject to the following two conditions:
  - (1) this device may not cause harmful interference, and
  - (2) this device must accept any interference received, including interference that may cause undesired operation.
19. CAUTION: Always completely disconnect the power cord from your chassis whenever you work with the hardware. Do not make connections while the power is on. Sensitive electronic components can be damaged by sudden power surges.
20. CAUTION: Always ground yourself to remove any static charge before touching the motherboard, backplane, or add-on cards. Modern electronic devices are very sensitive to static electric charges. As a safety precaution, use a grounding wrist strap at all times. Place all electronic components on a static-dissipative surface or in a static-shielded bag when they are not in the chassis.
21. CAUTION: Any unverified component could cause unexpected damage. To ensure the correct installation, please always use the components (ex. screws) provided with the accessory box.
22. Caution text concerning lithium batteries:



23. "Rack Mount Instructions - The following or similar rack-mount instructions are included with the installation instructions:
  - A) Elevated Operating Ambient - If installed in a closed or multi-unit rack assembly, the operating ambient temperature of the rack environment may be greater than room ambient. Therefore, consideration should be given to installing the equipment in an environment compatible with the maximum ambient temperature (T<sub>ma</sub>) specified by the manufacturer.
  - B) Reduced Air Flow - Installation of the equipment in a rack should be such that the amount of air flow required for safe operation of the equipment is not compromised.
  - C) Mechanical Loading - Mounting of the equipment in the rack should be such that a hazardous condition is not achieved due to uneven mechanical loading.
  - D) Circuit Overloading - Consideration should be given to the connection of the equipment to the supply circuit and the effect that overloading of the circuits might have on over current protection and supply wiring. Appropriate consid-

eration of equipment nameplate ratings should be used when addressing this concern.

E) Reliable Earthing - Reliable earthing of rack-mounted equipment should be maintained. Particular attention should be given to supply connections other than direct connections to the branch circuit (e.g. use of power strips)."

24. CAUTION :

To avoid any possible accident, please following instructions to operate this unit.

25. CAUTION :

Only the qualified engineer by Advantech Co.,Ltd can perform the installation in a vehicle. Improper installation can injure the operator or damage the vehicle and/or TREK-688 computer system.

Follow the installation as below to avoid overloading the circuit after adding this device.

Follow the instructions below to properly install the TREK-688 computing system in a vehicle.

- Determine the best location for mounting the unit taking into consideration the driver`s field of view and ease of accessing the unit. (Only install this unit in the car passenger compartment. Suggested locations are next to driver`s seat or located on center console.)
- Connect the vehicle computer to the vehicle`s wiring system as below.

#### Routing Electrical Cables

- Establish a near route for the cable, staying clear of moving parts or hot surfaces whenever possible.
  - Fix the cable to existing cable runs inside the vehicle using cable ties, but make sure they are away from any moving or hot surfaces.
  - When the cabling must go through a panel, use a suitable cable gland.
  - Ensure the cable does not have tight bends. The minimum recommended radius is 2.5".
  - Ensure cables do not swing or chafe on the structure.
  - DO NOT wind a cable in and out of the mesh on a cage.
  - Ensure that all fuses installed as instruction. 32 Volt is suitable for unit.
  - All power wiring must use the supplied power cable comply with intended applications of SAE with suitable ratings of electrical, temperature, exposure and flammability.
  - Fuses : UL LISTED Fuse for Automobile use.
    - A 10 amp.
  - Keep the path between the battery and the vehicle computer as short as possible and away from any part of the ignition high tension system.
- A 10 amp. If your car exhibits electrical problems, the fuse may blow and shut the system down to protect it from damage. Once the problem is rectified, replace the blown fuse and the system should again be operational.



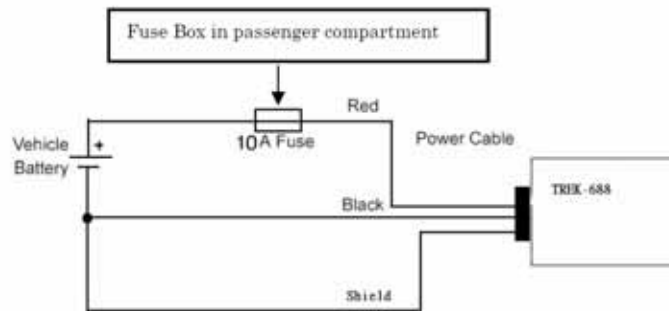

### Connecting the Power Cable

1. Disconnect the vehicle battery.
2. Connect the green wire to the vehicle's negative power source.  
NOTE see the vehicle Owner's Manual for specific wiring information.
3. Connect the red wire of Fuse Box in passenger compartment to vehicle's positive power source. Connect the black wire to the vehicle's negative power source. Then Fuse Box secured to connector. Insert the female connector of Fuse Box to the male connector of TREK-688 vehicle system. Connect the Orange wire to the vehicle's ignition switch.
4. Ensure the wiring connections created are sufficiently insulated from each other.
5. Re-connect the vehicle battery.
6. Insert the power cable connector into TREK-688 computing system power port. Align the keyway on the power connector with the notch on the vehicle computer's power port.



### CAUTION

Do not open the cover on the front side as illustration as below before turning off the power.

## Safety Precaution - Static Electricity

Follow these simple precautions to protect yourself from harm and the products from damage.

- » To avoid electrical shock, always disconnect the power from your PC chassis before you work on it. Don't touch any components on the CPU card or other cards while the PC is on.
- » Disconnect power before making any configuration changes. The sudden rush of power as you connect a jumper or install a card may damage sensitive electronic components.

This product is intended to be supplied by a Listed DC power source, rated 9~32Vdc, 7A minimum and Tma 55 degree C, if need further assistance with purchasing the DC power source, please contact Advantech for further information.

**Warning!** 1. *Input voltage rated: 9 ~ 32 Vdc.*



2. *Transport: carry the unit with both hands and handle with care.*
3. *Maintenance: to properly maintain and clean the surfaces, use only approved products or clean with a dry applicator.*
4. *CFast: Turn off the power before inserting or removing CFast storage cards.*

# Contents

<b>Chapter 1</b>	<b>General Information .....</b>	<b>1</b>
1.1	Introduction .....	2
1.2	General Specifications .....	3
1.3	Dimensions .....	5
	Figure 1.1 TREK-688 dimensions.....	5
<b>Chapter 2</b>	<b>System Setup.....</b>	<b>7</b>
2.1	A Quick Tour of the TREK-688 Computing Box.....	8
	Figure 2.1 Front view of TREK-688 .....	8
	Figure 2.2 Rear view of TREK-688 .....	8
2.1.1	Installing CFast & SIM card.....	9
2.1.2	Installing Storage.....	10
2.2	Installation Procedures	
2.2.1	Connecting the Power Cord.....	9
	Table 2.1: Pin Definition of Power Cord .....	9
2.2.2	Power Connector .....	9
	Figure 2.6 Power connector outlook.....	9
	Table 2.2: Pin Definition of Power Connector (Molex Manufacturer Part no.0430451200).....	10
	Figure 2.7 Power connector photo .....	10
2.3	Running the BIOS Setup Program .....	10
<b>Chapter 3</b>	<b>Switches setting and I/O Connectors.....</b>	<b>13</b>
3.1	Setting Switches.....	13
3.1.1	Switches List.....	13
3.1.2	Switch Location.....	13
3.1.3	Switch Setting.....	13
3.1.3.1	MiniPCIe (WWAN) Power Voltage Setup (SW2).....	13
3.1.3.2	MiniPCIe(WWAN) Support WWAN Module Setup (SW3).....	13
3.1.3.3	CAN BUS Termination(Only for test use)(SW6).....	14
3.1.3.4	MiniPCIe(WWAN) Power Voltage Setup (SW8).....	14
3.1.3.5	MiniPCIe(WWAN) Support WWAN Module Setup(SW9).....	14
3.1.3.6	I/O DB9 PIN9 Select (ON TOP LAYOUT)(CN15).....	14
3.2	LED Indicator.....	14
3.3	I/O Connectors Pin Assignment.....	15
3.3.1	Power Connector.....	15
3.3.2	HDMI Connector.....	15
3.3.3	Smart Display Connector.....	16
3.3.4	USB Connector (Rear side).....	17
3.3.5	USB Connector (Front side).....	18
3.3.6	VGA & RS-232 Connector.....	19
3.3.7	Video Input Connector.....	20
3.3.8	Vehicle I/O Connector.....	21
3.3.9	Generic I/O Connector.....	22
3.3.10	LAN Connector.....	23

# Chapter 4 Software Demo Utility Setup..... 29

4.1	Introduction.....	30
4.2	IVCP Demonstration.....	30
	4.2.1 Information.....	30
	4.2.2 Mode Control.....	31
	4.2.3 Low voltage Protection.....	32
	4.2.4 Event Delay.....	33
	4.2.5 Alarm.....	34
	4.2.6 Watchdog.....	35
	4.2.7 G-Sensor.....	36
	4.2.8 Peripheral.....	37
	4.2.9 Storage.....	38
	4.2.10 Digital IO.....	39
	4.2.11 P-sensor.....	40
4.3	VCIL Demonstration.....	41
	4.3.1 Port selection.....	41
	4.3.2 Information.....	42
	4.3.3 Option.....	43
	4.3.4 CAN/J1939/OBD2/J1708/J1587.....	44
4.4	Smart Display Demonstration.....	45
	4.4.1 Information.....	46
	4.4.2 Backlight.....	47
	4.4.3 Hot Key.....	48
	4.4.4 Peripheral.....	49
4.5	GPS Demonstration.....	50
	4.5.1 Port selection.....	50
	4.5.2 Information.....	51
	4.5.3 NEMA.....	52

---

# Chapter 1

## General Information

This chapter gives background information on the TREK-688 Premium In- Vehicle Computing Box.

Sections include:

- „ Introduction
- „ General Specifications
- „ Dimensions

# 1.1 Introduction

TREK-688 is an industrial-grade, powered by Intel® Haswell 4<sup>th</sup> generation dual core CPU computing box designed to provide high quality video surveillance and fleet management for eBus and BRT( Bus Rapid Transit). It can work in extreme environments with features like the wide working temperature range (-30-55°C) and anti-shock/vibration to pass MIL-STD-810G and 5M3 standard. Its special power protection surges from impacting the system. Guarding against damage from transient car power.

TREK-688 combined with variety of I/O connectors can be connected to devices like TPMS (Tire Pressure Monitoring System), Rear view Camera ( for parking monitoring) and CAN Bus devices. It has dual CAN BUS ports and support several kind of vehicle protocols (e.g. J1939,OBD-II) for vehicle diagnostics and driver behavior management. Build-in wireless communication (WWAN, WLAN,BT) enable TREK-688 to send import ant driver/vehicle/location/cargo information back to the control center. Furthermore, TREK-688 also reserved three displays/dual audio interfaces supporting different resolutions can deliver different applications to different displays; eg:one application to a fleet driver and another to passenger to IVI and digital signage application.

## TREK-688 I/O Overview

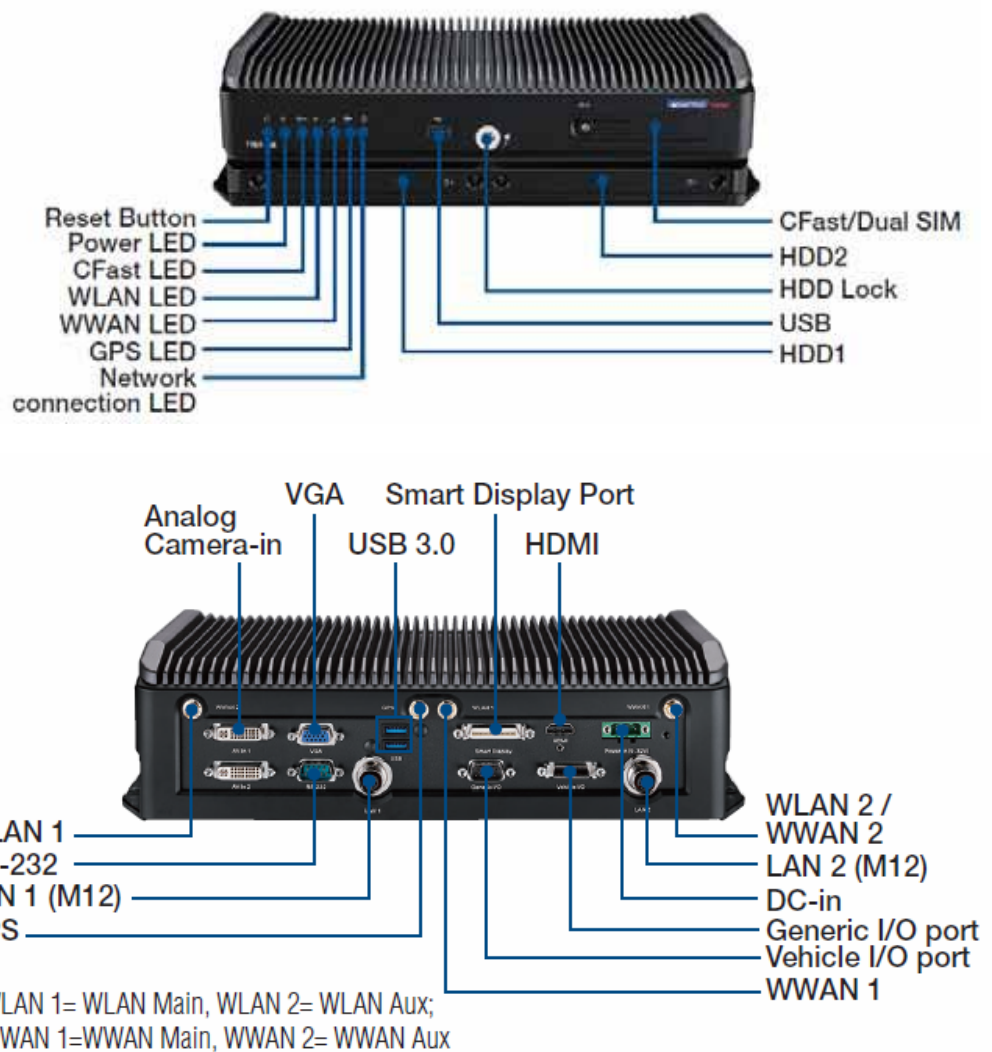

## 1.2 General Specifications

### Features

- Intel® Haswell Core™ i7 Dual core high performance processor for multitasking.
- Embedded video encoder supports up to 12 analog video inputs for D1, 30fps resolution and 8 audio inputs
- Dual external HDD/SSD tray with key-lock protection.
- Easily paired with TREK in-vehicle smart displays via a single-cable connection.
- Intelligent vehicle power management system for ignition on/off/delay and power protection functions.
- Vehicle diagnostic interface with configurable dual CAN(J1939,OBD-II/ISO 15765) and J1708 protocols.
- Built-in LTE/GNSS/WLAN/BT (with dual SIM cards) modules.
- Advanced Shock & anti-vibration certified by MIL-STD-810G, EN60721-3(5M3)
- Rich management & video SDK , test utility for customer evaluating.

### Specifications

Core	Processor	Intel® Core™ i7-4650U Dual Core, 2.9GHz (i3-4010U & i5-4300U by project support)
	Memory	1 x SO-DIMM socket Up to 8GB DDR3L-1600 Non-ECC memory module; (Default configuration: 4GB)
	Graphic	Intel HD graphics 4400 1.1GHz
	Video HW Encoder	Stretch S7, support H.264, MJPEG format; Resolution up to D1, 30fps per channel
	O.S	Windows 7 pro 32bit as default. WES7, WE8S 32bit by project support Linux Fedora 18 Remix (kernel 3.8.0) (32-bit) by project support
Storage	CFast	1 x external accessible CFast slot with cover, support system boot up Default configuration: 16GB, SLC SQFlash CFast card
	mSATA	1 x mSATA slot, support system boot up Default configuration: N/A; BOM optional, by project-based
	HDD/SSD	2 x external accessible 2.5" Mobile HDD/SSD tray with key-lock protection, support system boot up (Optional) Support SATA Gen2 (3Gb/s)
Display	Smart Display Port (*1)	12V/2A power output for TREK-30x 1 x 18-bits LVDS (Resolution : 800x480 (TREK-303), 1024 x768 (TREK-306); default TREK-306) 1 x Line-Out (*2) (For Speakers on TREK-30x) 2 x UART (TX/RX, TX/RX/RTS) (For T/S, Hot keys, brightness, light sensor control) 1 x USB 2.0 Type A 1 x PWR Button Signal 1 x Reset Button Signal
	HDMI	1 x HDMI 1.3b (Resolution up to 1920 x 1080)
	VGA	1 x DB15 (Resolution up to 2560 x 1600)
I/O	Vehicle I/O Port	2 x CAN Bus (Support Raw CAN, J1939, OBD-II/ISO 15765; FW configurable) 1 x J1708 (Support J1587) 1 x 4-wire RS-232/422/485 (Default RS-485, by software setting)
	Generic I/O Port	2 x 4-wire RS-232 4 x Isolated DI (Dry Contact) 4 x Isolated DO (Open collector output, driving by relay) 1 x Line-Out (*2) 1 x Mic-In
	Standard I/O Port	1 x USB 2.0 Type A (Front side) 2 x USB 3.0 Type A (Rear side, with cable clip) 1 x High Speed Full RS-232, DB-9 (Pin 9 = Ring, 12V/5V @ 0.5A is BOM optional by jumper setting) 2 x Giga LAN, with 8-pin M12 connector
	Video / Audio input	16-ch Video inputs, Video Compression: support H.264, MJPEG

	(AV1 & AV2, via dual DVI-I connector)	format; Resolution up to D1, 30fps per channel, total 480fps. 8-ch mono Audio inputs, Audio Compression: G.711
	LED	6 x LEDs (Power (Red), CFast (Yellow), WLAN (Green), WWAN (Green), GPS (Yellow), Network connection (Yellow))
	Power Button	Via TREK-30x (In-Vehicle Smart Display); System is powered on by Ignition in default
	Reset Button	1 x Reset button (Front side)
RF	WLAN + Bluetooth	IEEE 802.11a/b/g/n + Bluetooth 4.0 combo module via Full Mini-PCIe Slot
	WWAN	4G (LTE,HSPA+,GSM/GPRS/EDGE, EV-DO Rev a1, 1xRTT): Sierra Wireless MC73xx via Full Mini-PCIe Slot (Default: MC7354 for US/ MC7304 for EU)
	GNSS	Build-in u-blox MAX-M8W GPS/Glonass/Beidou module, support AGPS
	Antenna	4 x SMA type antenna hole for GPS, WiFi+ BT, WWAN/LTE MIMO. (*3)
Power	Voltage input	Supports 12/24 V car power system. (9V ~ 32V wide DC input, ISO 7637-2 & SAE J1113 compliant.)
	Intelligent Vehicle Power Management (iVPM 2.0)	System power on/off/hibernate management (e.g. Programmable Ignition On/Off Time delay) Support Wake up Events: - Alarm (RTC) Wake up. - Wake up by Call/SMS. - Wake up by G-sensor. System power protection (e.g. Car Battery Low Voltage Protection) System monitoring and diagnostic
Mechanical	Dimensions (W x H x D)	346 x 92.5 x 196.2 mm
	Weight	5.9 kg (with two HDDs)
Environment	IP Rating	IP30
	Vibration/Shock	MIL-STD-810G, EN60721-3(5M3)
	EMC	CE,FCC
	Safety	UL/cUL, CB
	Vehicle Regulation	E-Mark (E13), SAE J1455 class C, ISO 7637-2, SAE J1113, EN50155, IEC 60571
	RF Regulation	CE (R&TTE), FCC ID
	Operating Temperature	-30° C ~ 55° C
Storage Temperature	-40° C ~ 80° C	

\*1: To be paired with TREK-303/306 directly. (Single-cable connection)

\*2: Support dual independent audio streams. (i.e. The Line-Out interface in "Smart Display Port" and "Generic I/O Port" are driven by different Audio codecs.)

\*3: The connector type on box side is Female RP-SMA connector. (i.e. Female connector body (outside threads) with a male inner pin contact.)



### 1.3 Dimensions

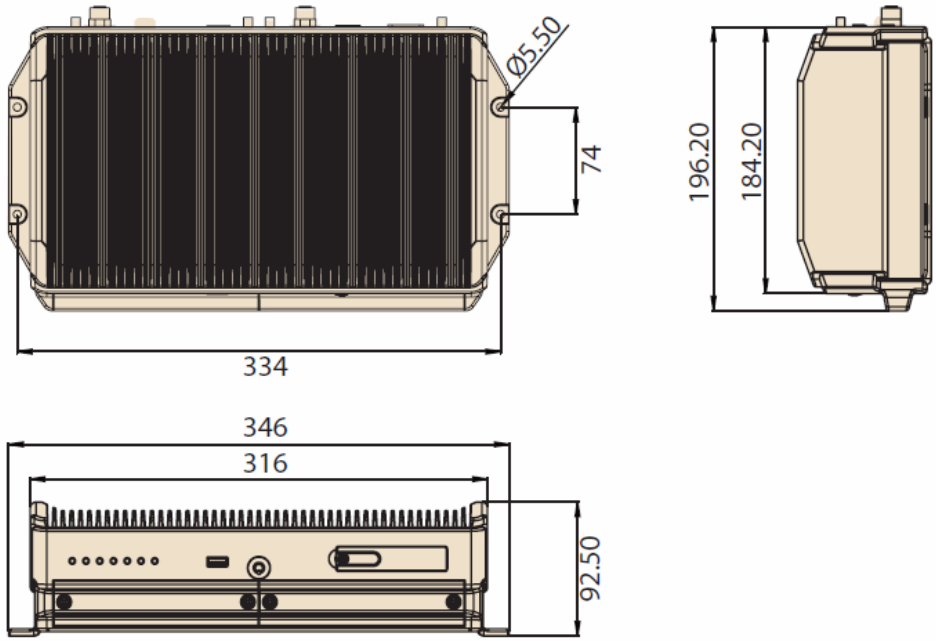

Figure 1.1 TREK-688 dimensions

# Chapter 2

## System Setup

This chapter details system setup on TREK-688

Sections include:

- A Quick Tour of the Computer Box
- Installation Procedures
- Running the BIOS Setup Program

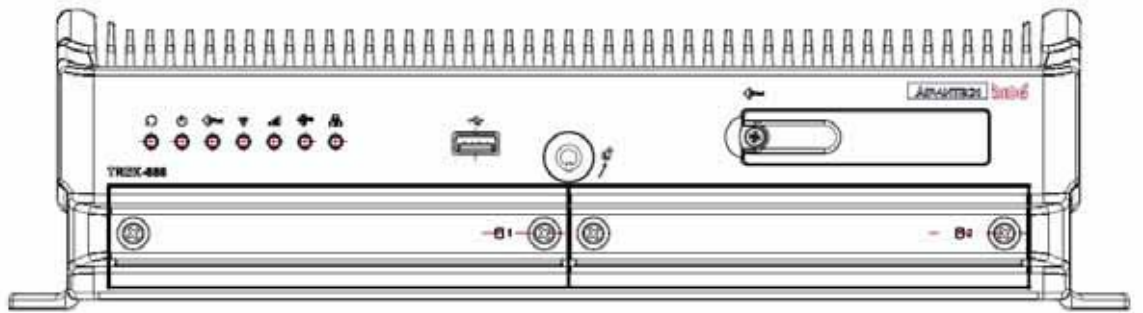

Figure 2.1 Front view of TREK-688

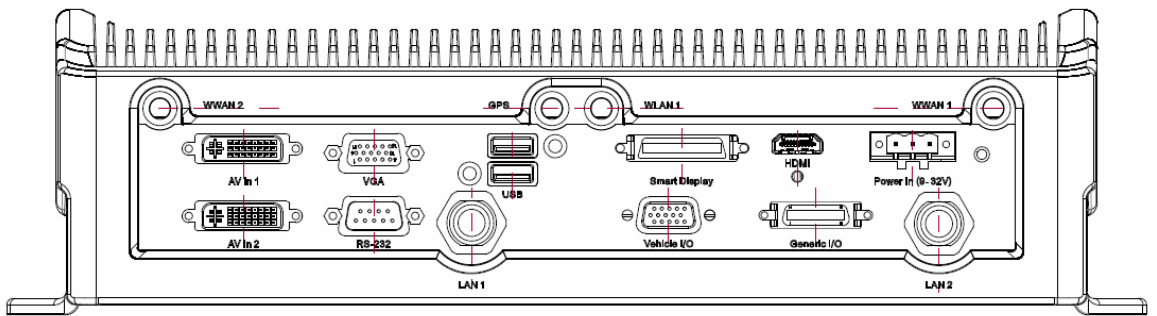

Figure 2.2 Rear view of TREK-688

## 2.1.1 Installing CFast Card & SIM card

Remove CFast door screw and can install CFast Card & SIM Card directly. Please insert SIM Card from SIM1 slot because default priority is SIM1. If you insert to SIM2 slot, you have to modify setting of SDK.

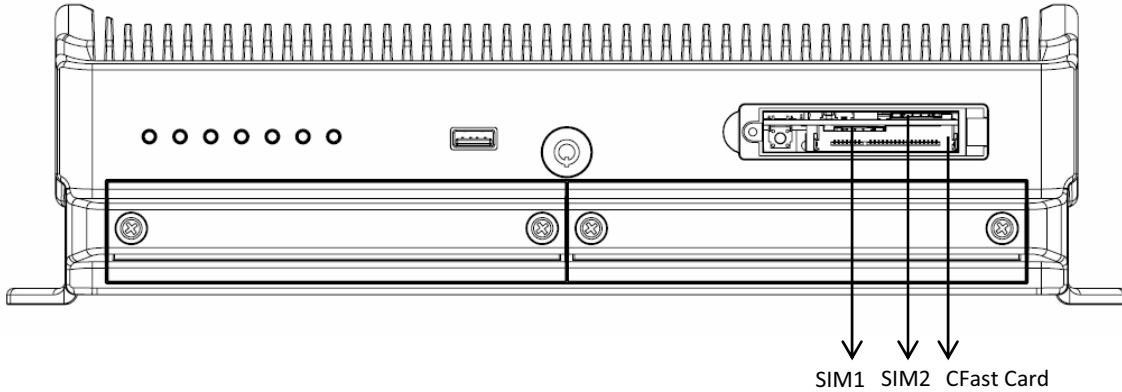
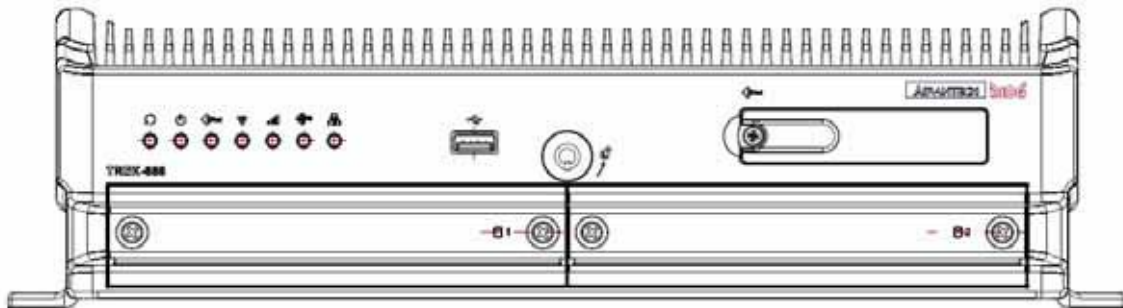

Figure 2.3 Installing CFast card & SIM card

## 2.1.2 Installing Storage

1. Release 2pcs screws of each HDD/SDD Tray and pull out the tray.



2. Remove 8pcs screws of HDD/SSD tray top cover and take out the HDD/SSD frame. Insert HDD/SSD into the frame and fix by 4pcs screws.
3. Fix HDD/SSD tray top cover by 8pcs screws.

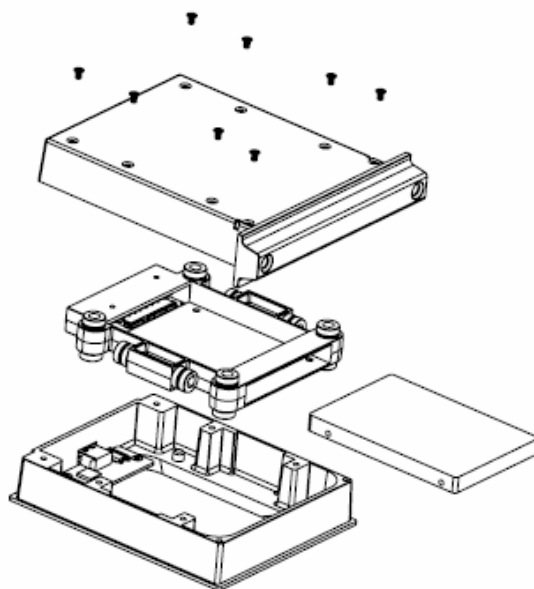

**Warning!** Do not remove the HDD/SSD tray when system running. Power must be switched off in advance. Take care in order to avoid injury or damage to the equipment.

## 2.2 Installation Procedures

### 2.2.1 Connecting the Power Cord

Connect the three pin waterproof power cord to the DC inlet of the In-Vehicle Computing Box. On the open-wire end, one pin is reserved for positive voltage and is marked, "+"; one pin is reserved for ground and is marked, "-"; and, one pin is reserved for the ignition signal with an "ignition" mark.

**Note!**  *Ignition on/off setting: The TREK-688 supports an ignition on/off function so that you can power on/off the TREK-688 via the ignition signal/voltage and connect the TREK-688 vehicle ignition switch.*

**Table 2.1: Pin Definition of Power Cord**

Pin	Definition	Color
1	-	Black
2	+	Red
3	Ignition	Orange

### 2.2.2 Power Connector

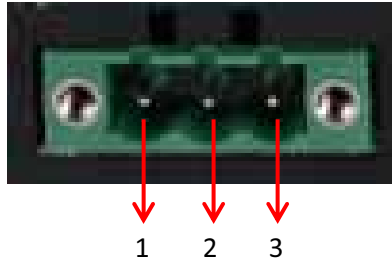

**Figure 2.6 Power connector outlook**

<b>Table 2.2: Power connector</b>			
<b>Pin</b>	<b>Signal</b>	<b>Pin</b>	<b>Signal</b>
1	Ground	2	Power input (9~32VDC)
3	Acc ignition input		

---

## 2.3 Running the BIOS Setup Program

In most cases, the computer will have been properly set up and configured by the dealer or SI prior to delivery. However, it may still be necessary to adjust some of the computer's BIOS (Basic Input-Output System) setup programs to change the system configuration data, like the current date and time, or the specific type of hard drive currently installed.

The setup program is stored in read-only memory (ROM). It can be accessed either when turning on or resetting the computer, by pressing the "Del" key on the keyboard immediately after powering up the computer.

The settings that are specified with the setup program are recorded in a special area of the memory called CMOS RAM. This memory is backed up by a battery so that it will not be erased when turning off or resetting the system. Whenever the power is turned on, the system reads the settings stored in CMOS RAM and compares them to the equipment check conducted during the power on self-test (POST). If an error occurs, an error message is displayed on screen, and the user is prompted to run the setup program.

# Chapter 3

## Switches Setting and Connectors

This chapter explains how to set up the In-Vehicle Computing Box hardware, including instructions on setting and how to set switches and read indicators.

Sections include:

- Setting Switches
- Indicators introduction
- I/O connectors pin assignment



## 3.1 Setting Switches

It is possible to configure the In-Vehicle Computing Box to match the needs of the application by resetting the switches.

### 3.1.1 Switches List

Switches	Description
SW2	MiniPCle (WWAN) Power Voltage Setup
SW3	MiniPCle (WWAN) Support WWAN Module Setup
SW6	CAN BUS Termerater (Only for test use)
SW8	MiniPCle (WWAN) Power Voltage Setup
SW9	MiniPCle (WWAN) Support WWAN Module Setup
CN15	I/O DB9 PIN 9 select (ON TOP LATOUT)

### 3.1.2 Switches Location

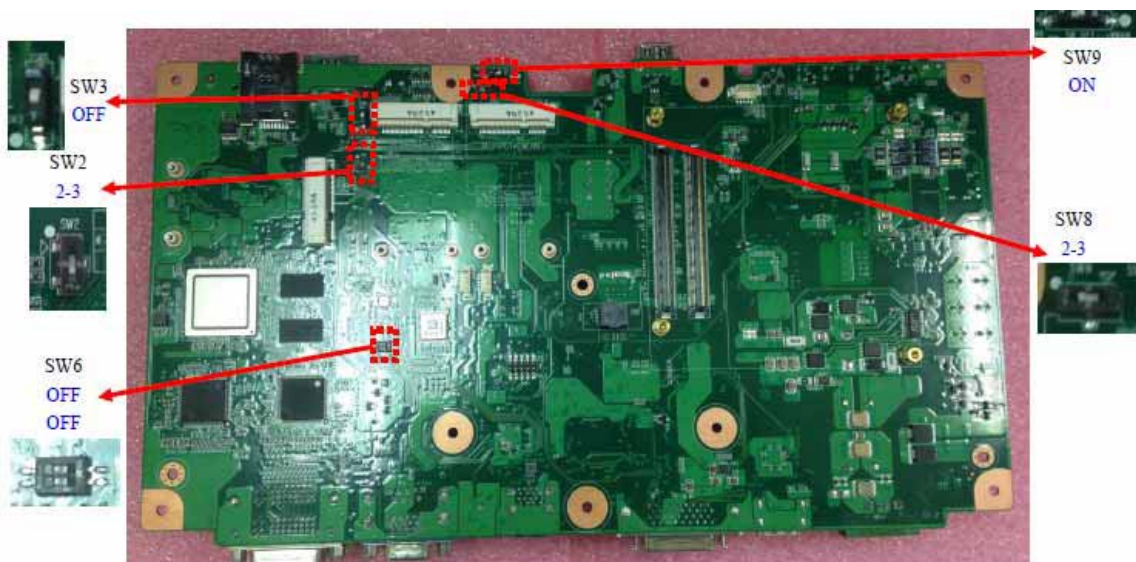

### 3.1.3 Switches setting

#### 3.1.3.1 MiniPCle (WWAN) Power Voltage Setup (SW2)

	SW2	
*3.7V	1-2	Support MC809X
3.3V	2-3	Standard MiniPCle / HE-910

Default Setup on Support MC809X

#### 3.1.3.2 MiniPCle (WWAN) Support WWAN Module Setup (SW3)

ON	For standard MiniPCle (for WLAN)
OFF	Support LTE/3.5G Module (for WWAN) (Default)

### 3.1.3.3 CAN BUS Termination (Only for test use) (SW6)

ON/ON	Disable (Default)
OFF/OFF	Enable CAN BUS Terminator

### 3.1.3.4 MiniPCIe (WWAN) Power Voltage Setup (SW8)

	SW8	
3.7V	1-2	Support MC809X
*3.3V	2-3	Standard MiniPCIe

Default Setup on Standard MiniPCIe

### 3.1.3.5 MiniPCIe (WWAN) Support WWAN Module Setup (SW9)





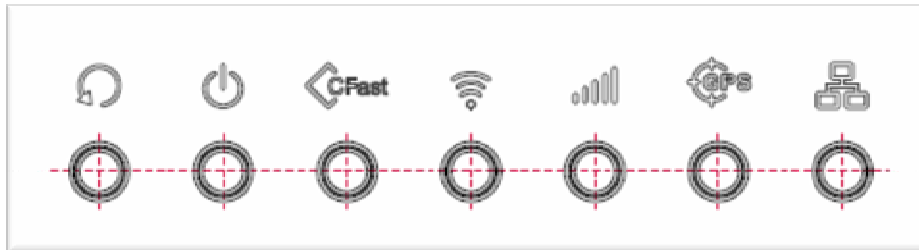

ON	For standard MiniPCIe (for WLAN) (Default)
OFF	Support LTE/3.5G Module (for WWAN)

### 3.1.3.6 I/O DB9 PIN9 select (ON TOP LAYOUT) (CN15)

1-2	Ring (Default)
2-3	Power_+12V/0.5A

## 3.2 LED Indicator



	System Reset Button	Force the system to reboot.
	Power Activity indicator LED	When the system is in NORMAL mode, this LED will be light up.(Red color)
	CFast Activity Indicator LED	The storage activity indicator is a green LED, and flashes to show the activity of CFast.(Orange color)
	WLAN Activity Indicator LED	The WLAN activity indicator is an orange LED, and flashes to show the activity of the WLAN module.(Green color) This LED is controlled directly by the WLAN module.
	WWAN Activity Indicator LED	The WWAN activity indicator is a green LED, and flashes to show the activity of the WWAN module.(Green color) This LED is controlled directly by the WWAN module.
	GPS Activity Indicator LED	The GPS activity indicator is an orange LED, and is used to show GPS activity. This LED is controlled directly by the GPS chips.(Orange color)
	LAN Activity Indicator LED	The LAN activity indicator is a green LED, and flashes to show the activity of the LAN data transportation. (Green color)

### System power indicator LED



Red LED keep light  
Normal mode  
System is in NORMAL mode



Red LED flashing  
Boot loader mode  
F/W can be update

## 3.3 I/O Connectors Pin Assignment

### 3.3.1 Power connector

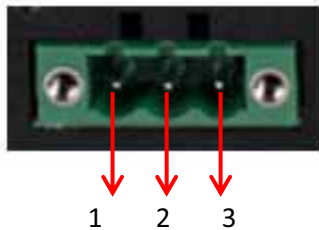
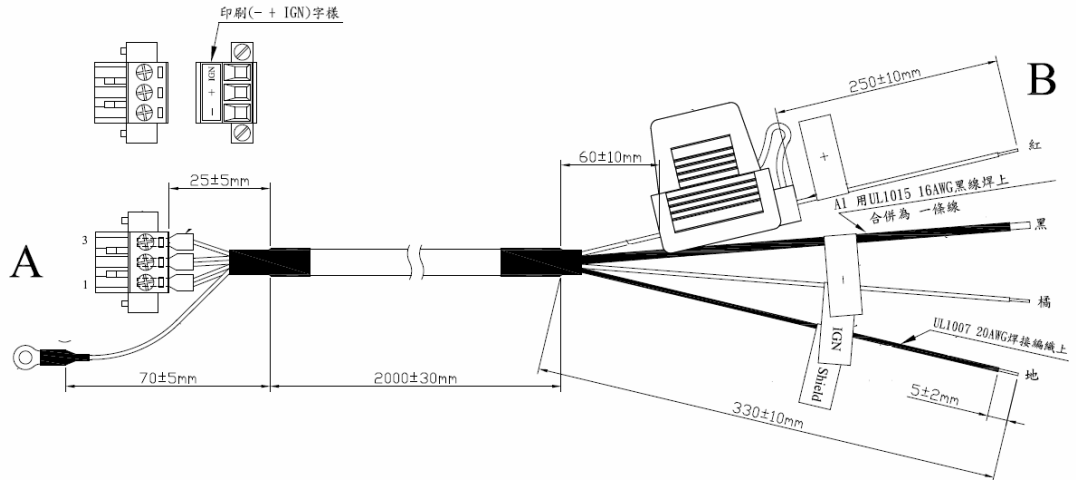

**Table 3.1: Power connector**

Pin	Signal	Pin	Signal
1	Ground	2	Power input (9~32VDC)
3	Acc ignition input		

#### 3.3.1.1 Power in Jack Cable





Connector Type: M12 JACK GT238134-0205Z-JG-01 MALE 5P\*1

Table 1: Power M12 JACK Cable Pin Depiction		
PIN	Signal Depiction	Cable / Label
1	Power Ground	■ / -
2	Power Input (9 ~ 32 VDC)	■ / +
3	Acc Ignition Input	■ / IGN
	Shield Ground	■ / Shield

Fuse Spec: 58V/10A\*1

### 3.3.2 HDMI Connector

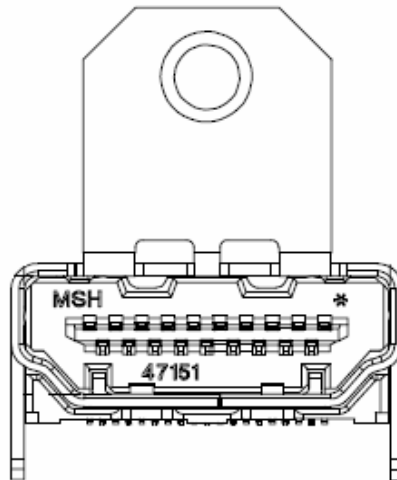

Connector type: HDMI Conn. 19P 0.5mm 90D(F) SMD 471511002

Table HDMI Connector Pin Assignment

Pin	Signal Depiction	Pin	Signal Depiction
1	HDMI_DATA2P	11	GND

2	GND	12	HDMI_CLKN
3	HDMI_DATA2N	13	NC
4	HDMI_DATA1P	14	NC
5	GND	15	HDMI_CTRLCLK
6	HDMI_DATA1N	16	HDMI_CTRLDATA
7	HDMI_DATA0P	17	GND
8	GND	18	HDMI_Power(5V)
9	HDMI_DATA0N	19	HDMI_HPD
10	HDMI_CLKP		

### 3.3.3 Smart Display Connector

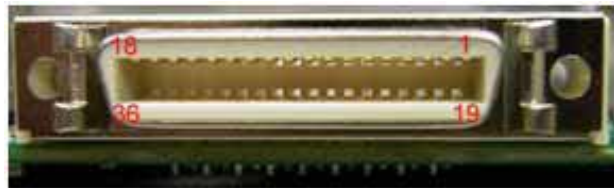

Pin	Signal	Pin	Signal
1	Backlight Enable output #	2	Panel Power Enable output #
3	LVDS Ground	4	Reset Button Input #
5	LVDS Clock +	6	LVDS Clock -
7	LVDS Ground	8	LVDS Ground
9	LVDS Data2 +	10	LVDS Data2 -
11	RS232 TXD1 #	12	RS232 RXD1 #
13	LVDS Data1 +	14	LVDS Data1 -
15	LVDS Ground	16	LVDS Ground
17	LVDS Data0 +	18	LVDS Data0 -
19	USB D-	20	USB D+
21	USB Ground	22	USB Ground
23	+12 V <sub>DC</sub> output (+/- 5%, max 1A)	24	+12 V <sub>DC</sub> output (+/- 5%, max 1A)
25	+12 V <sub>DC</sub> output (+/- 5%, max 1A)	26	+12 V <sub>DC</sub> output (+/- 5%, max 1A)
27	Power Ground	28	Power Ground
29	Power Ground	30	Power Ground
31	RS232 TXD2 #	32	RS232 RXD2 #
33	RS232 RTS2	34	Power Button Input #
35	Audio Ground	36	Mono. Line-out

### 3.3.3.1 Smart Display Cable (P/N: 1700020007)

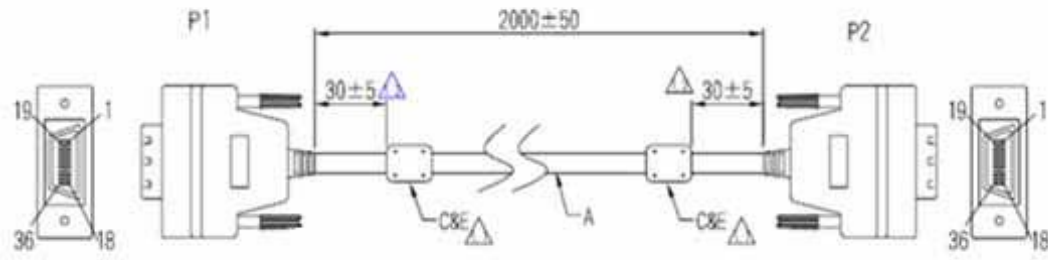

#### Pin assignment

P1	1	2	3	4	5	6	7	8	9	10	11	12	13	14	15	16	17	18
P2	1	2	3	4	5	6	7	8	9	10	11	12	13	14	15	16	17	18
Color	Brown	White	Ground	Brown	red	white	Ground	Ground	white	red	yellow	white	Ground	Ground	Green	white		



19	20	21	22	23	24	25	26	27	28	29	30	31	32	33	34	35	36
19	20	21	22	23	24	25	26	27	28	29	30	31	32	33	34	35	36
Blue	white	Ground	yellow	Black	Blue	Purple	Grey	white	Black	Black	black	Orange	Black	Black	Black	Black	Black
										Brown	red		Yellow	green	blue	purple	grey



### 3.3.4 USB Connector (Rear side)

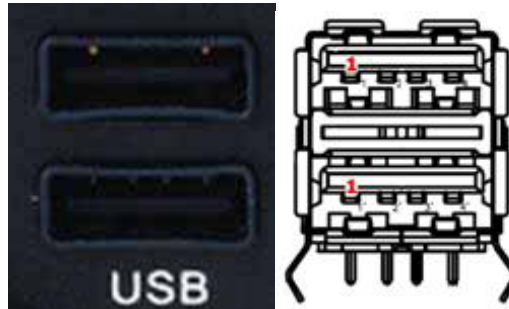

Connector type: Stack USB A-Type Receptacle DIP UB1112C-8FDE-4F

Table 3. : USB Connector

Pin	Signal Depiction
1	Vcc
2	USB_Data-
3	USB_Data+
4	GND

### 3.3.5 USB Connector (Front side)

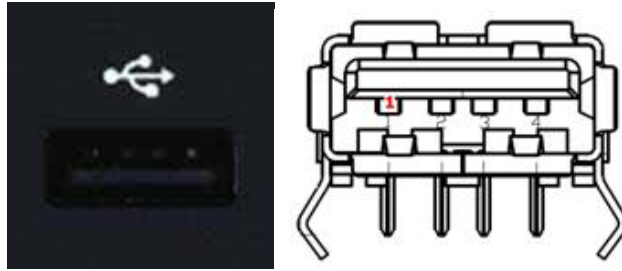

Connector type: Single USB A-Type Receptacle DIP UB1112C-4K1-4F

**Table 3. : USB Connector**

Pin	Signal Depiction
1	Vcc
2	USB_Data-
3	USB_Data+
4	GND

### 3.3.6 VGA & RS-232 Connector

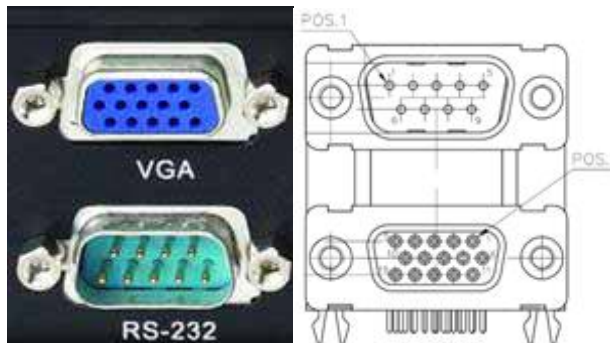

Connector type: D-SUB Conn. 9P+15P 90D (M/F) DIP DM10191-H551-4F

**Table 3. : VGA Connector**

Pin	Signal Depiction	Pin	Signal Depiction
1	CRT R	9	CRT POWER +5VDC ( $\pm 5\%$ , max 1A)
2	CRT G	10	Ground
3	CRT B	11	NC
4	NC	12	CRT DDC_DATA
5	Ground	13	CRT HSYN
6	Ground	14	CRT VSYN
7	Ground	15	CRT DDC_CLK
8	Ground		

**Table 3. : RS-232 Connector**

Pin	Signal Depiction	Pin	Signal Depiction
1	RS-232 DCD	5	RS-232 Ground
2	RS-232 RXD	6	RS-232 DSR
3	RS-232 TXD	7	RS-232 RTS
4	RS-232 DTR	8	RS-232 CTS
		9	RS-232 RI/ +12 VDC output

### 3.3.7 Video Input Connector

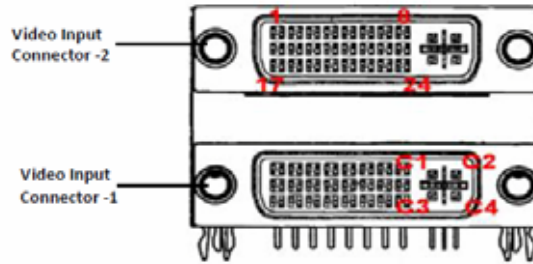

Connector type : DVI-I 29P/DVT-I 29P 1.905mm  
 Female right angle DIP C1DA2G2-020-R

Table 3. : Video Input Connector 1

Pin	Signal Depiction	Pin	Signal Depiction
1	Video Input Channel 1	15	Digital Ground
2	Video Input Channel 2	16	Digital Ground
3	Video Input Channel 3	17	RS-485 N
4	Video Input Channel 4	18	RS-485 P
5	Audio Input Channel 1	19	Digital Ground
6	Audio Input Channel 2	20	Digital Ground
7	Audio Input Channel 3	21	Video Input Channel 5
8	Audio Input Channel 4	22	Video Input Channel 6
9	Digital Ground	23	Video Input Channel 7
10	Digital Ground	24	Video Input Channel 8
11	Digital Ground	C1	+ 12 VDC output
12	+ 12 VDC Output Enable#	C2	+ 12 VDC output
13	Digital Ground	C3	+ 12 VDC output
14	Digital Ground	C4	+ 12 VDC output

Table 3. : Video Input Connector 2

Pin	Signal Depiction	Pin	Signal Depiction
1	Video Input Channel 9	15	Digital Ground
2	Video Input Channel 10	16	Digital Ground
3	Video Input Channel 11	17	RS-485 N
4	Video Input Channel 12	18	RS-485 P
5	Audio Input Channel 5	19	Digital Ground
6	Audio Input Channel 6	20	Digital Ground
7	Audio Input Channel 7	21	Video Input Channel 13
8	Audio Input Channel 8	22	Video Input Channel 14
9	Digital Ground	23	Video Input Channel 15
10	Digital Ground	24	Video Input Channel 16
11	Digital Ground	C1	+ 12 VDC output
12	+ 12 VDC Output Enable#	C2	+ 12 VDC output
13	Digital Ground	C3	+ 12 VDC output
14	Digital Ground	C4	+ 12 VDC output

### 3.3.7.1 Video Input Cable (P/N:1700022702-01)



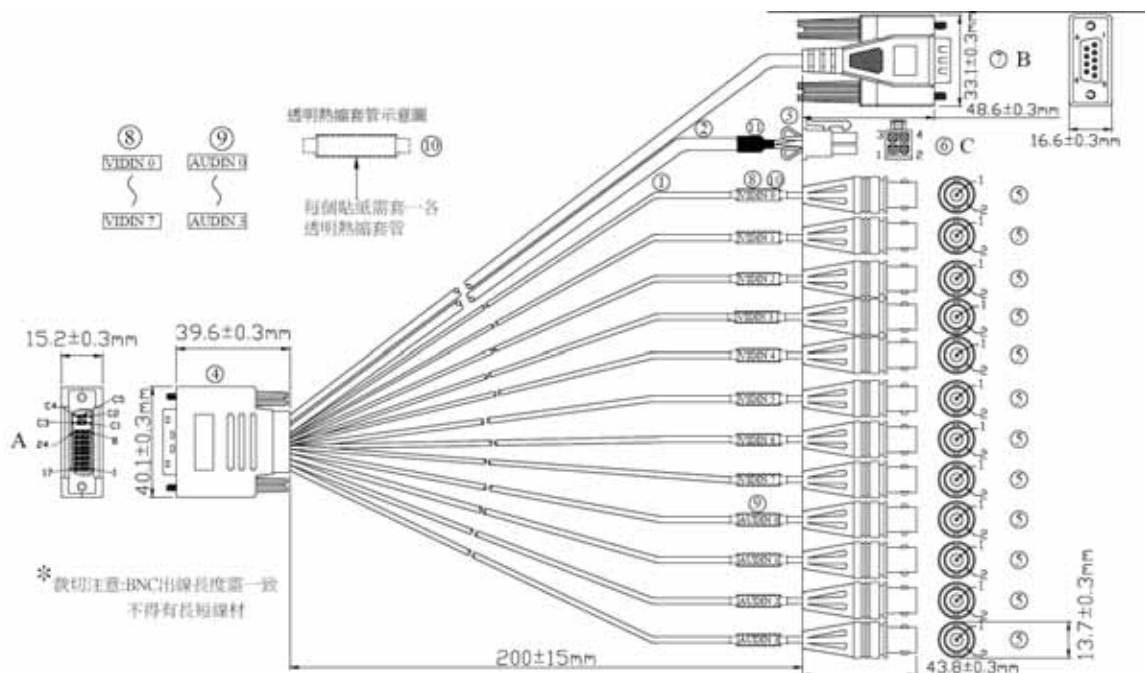
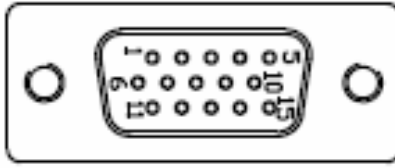

**Table : Video Input Cable Connector Pin Depiction**

HOUSING C4255HF 2*02P (PH4.2)		9P D-SUB MALE CONNECTOR( B )		<b>(YELLOW BNC)</b>		<b>(RED BNC)</b>	
Power Output		RS-485		VIDEO INPUT		AUDIO INPUT	
PIN	Depiction	PIN	Depiction	PIN	Depiction	PIN	Depiction
1,2	+12V/2A (NC)*	1	RS485-N	1	VIDEO INPUT	1	AUDIO INPUT
3,4	GND (NC)*	2	RS485-P	2	GND	2	GND

**P.S : TREK-688 doesn't support +12V output**

### 3.3.8 VI/O Connector



VI/O Port is TREK's next generation communication interface connector which contains Dual CAN Bus and Single J1708 interface.

All new TREK x86 computing box (e.g. TREK-688, TREK-674) can share the same one VI/O cable.

Connector type: 15PIN D-SUB MALE CONNECTOR

**Table VIO Connector Pin Assignment**

Pin	Signal Depiction	Pin	Signal Depiction
1	CAN_H	9	ODB_CAN_H_R
2	CAN_L	10	J1708_GND
3	ODB_CAN_GND	11	VIOCOM_R485P
4	J1708_DN	12	VIOCOM_422RXP
5	J1708_DP	13	VIOCOM_R485N
6	NC	14	VIOCOM_422RXN
7	CAN_GND	15	VIOCOM_232GND
8	ODB_CAN_L		

### 3.3.8.1 Vehicle I/O Cable (P/N:1750023051-01)



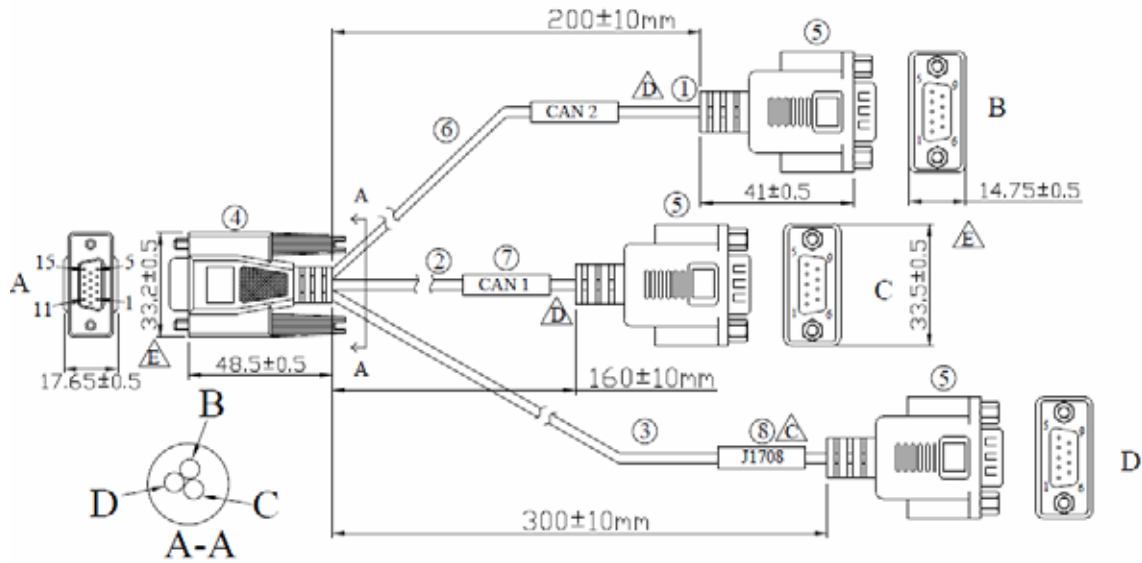

CONNECTOR TYPE: (D-SUB 15P MALE \*1) (D-SUB 9PIN MALE\*4)

**Table : DB15 Cable Connector Pin Depiction**

B (D-SUB 9PIN MALE)		C (D-SUB 9PIN MALE)		D (D-SUB 9PIN MALE)			
CAN 2 BUS		CAN 1 BUS		J1708			
PIN	Depiction	PIN	Depiction	PIN	Depiction	PIN	Depiction
2	CAN2_L	2	CAN1_L	1	J1708_N	2	485P/422TXP/232-RXD
7	CAN2_H	7	CAN1_H	4	J1708_P	6	485N/422TXP/232-CTS
3	CAN2_GND	3	CAN1_GND	8	J1708_GND	3	422RXP/232-TX
				5	COM-GND	7	422RXN/232-RTS

### 3.3.9 Generic I/O Connector

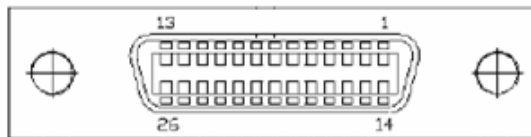

Generic I/O Port is TREK's next generation high density connector which provides several common I/O interface for peripheral control but it is more compact and cost effective than the HDC connector (a.k.a. Extended I/O Port) on TREK-688.

All new TREK x86 computing box (e.g. TREK-688, TREK-674) can share the same one Generic I/O cable. However, there are some pin assignment different on TREK-688 and TREK-674.

Connector type: D-SUB Conn. 26P 1.27mm 90D(F) DIP MCR26FL33

**Table GIO Connector Pin Assignment**

Pin	Signal Depiction	Pin	Signal Depiction
-----	------------------	-----	------------------

1	ISO_DI1#	14	ISO_RELAYOUT1#
2	ISO_DI2#	15	ISO_RELAYOUT2#
3	ISO_DI3#	16	GIO_GND_DIO
4	ISO_DI4#	17	GIOCOMA_232_RXD
5	GIO_GND_DIO	18	GIOCOMA_232_TXD
6	ISO_RELAYOUT3#	19	GIOCOMA_232_RTS#
7	ISO_RELAYOUT4#	20	GIOCOMA_232_CTS#
8	GIO_GND_COM	21	GIO_GND_COM
9	NC	22	GIOCOMB_232_RXD
10	NC	23	GIOCOMB_232_TXD
11	GND_AUD	24	GIOCOMB_232_RTS#
12	GIO_MIC_IN	25	GIOCOMB_232_CTS#
13	GIO_LINE_OUT	26	GIO_GND_COM

### 3.3.9.1 Generic I/O Cable (P/N:1700023050-01)



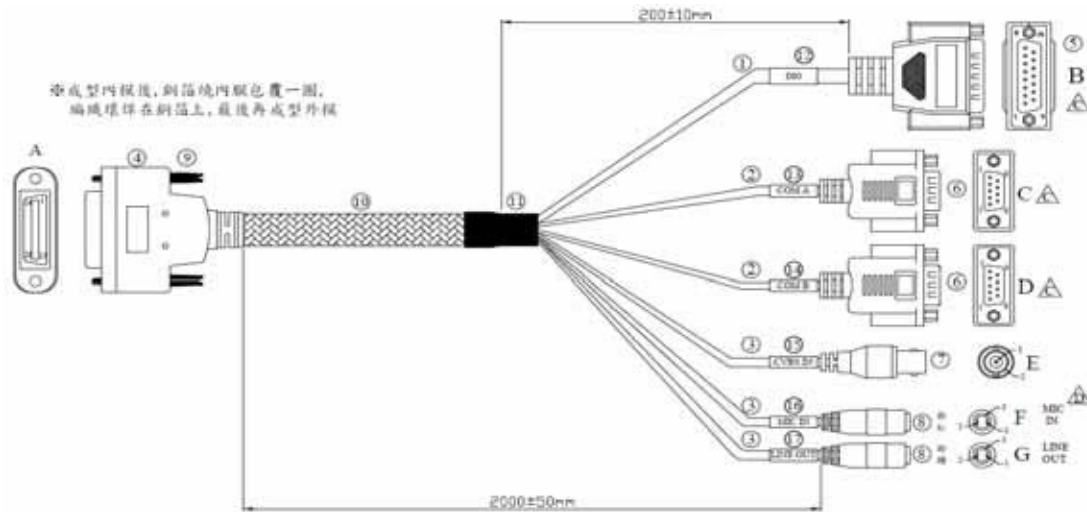

**GIO Table -1: Cable Pin Depiction**

15PIN D-SUB MALE CONNECTOR (B)		9PIN D-SUB MALE Connector(C)		9PIN D-SUB MALE Connector (D)	
ISO_DIO(4DI & 4DO)		RS232(4-Wire)		RS232(4-Wire)	
PIN	Depiction	PIN	Depiction	PIN	Depiction
1	ISO_DI1	9	ISO_DO1	2	232-RXD
2	ISO_DI2	10	ISO_DO2	3	232-TXD
3	ISO_DI3	13	ISO_DO3	7	232-RTS
4	ISO_DI4	14	ISO_DO4	8	232-CTS
5	ISO_GND	6	ISO_GND	5	COM_GND

**GIO Table -2: Cable Pin Depiction**

BNC JACK (E)		3.5⊕ PHONE JACK (F)		3.5⊕ PHONE JACK (G)	
CVBS In		MIC_IN		LINE OUT	
PIN	Depiction	PIN	Depiction	PIN	Depiction
1	CVBS In (NC)*	1+2	MIC_IN	1+2	LINE OUT
2	GND (NC)*	2	MIC_GND	2	Audio-GND

P.S TREK-688 doesn't support CVBS In function.

### 3.3.10 LAN Connector

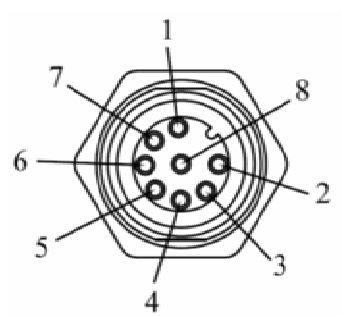

Connector type: M12 A-coding Jack GT234102-01080 female 8P

**Table LAN Connector Pin Assignment**

<b>Pin</b>	<b>Signal Depiction</b>	<b>Pin</b>	<b>Signal Depiction</b>
1	LAN TRP0P	5	LAN TRP2N
2	LAN TRP0N	6	LAN TRP1N
3	LAN TRP1P	7	LAN TRP3P
4	LAN TRP2P	8	LAN TRP3N



# Chapter 4

## Software Demo Utility Setup

This appendix explains the software demo utility for TREK-688

Sections include:

- „ Introduction
- „ How to Set up Demo Utility



## 4.1 Introduction

Advantech has developed demo utilities based on Advantech provided SDK APIs to let user test the functions on TREK-688. This document describes the usage of each demo utilities and also provide a basic concept of the application development on TREK-688.

For technical support, contact Advantech application engineers worldwide. For news updates, please visit our website : [www.advantech.com](http://www.advantech.com) and MRM forum : <http://mrmforum.advantech.com/index.aspx>

## 4.2 IVCP Demonstration

The IVCP demonstration application demonstrate the usage of MRM IVCP API which is a lightweight interface between OS (Operating system) and IVCP (Intelligent Vehicle Co-Processor) allow user to access the status of machine and change machine behavior such as power management, boot behavior, peripheral control etc.

### 4.2.1 Information

In this page, the demo application shows the current status and basic information.

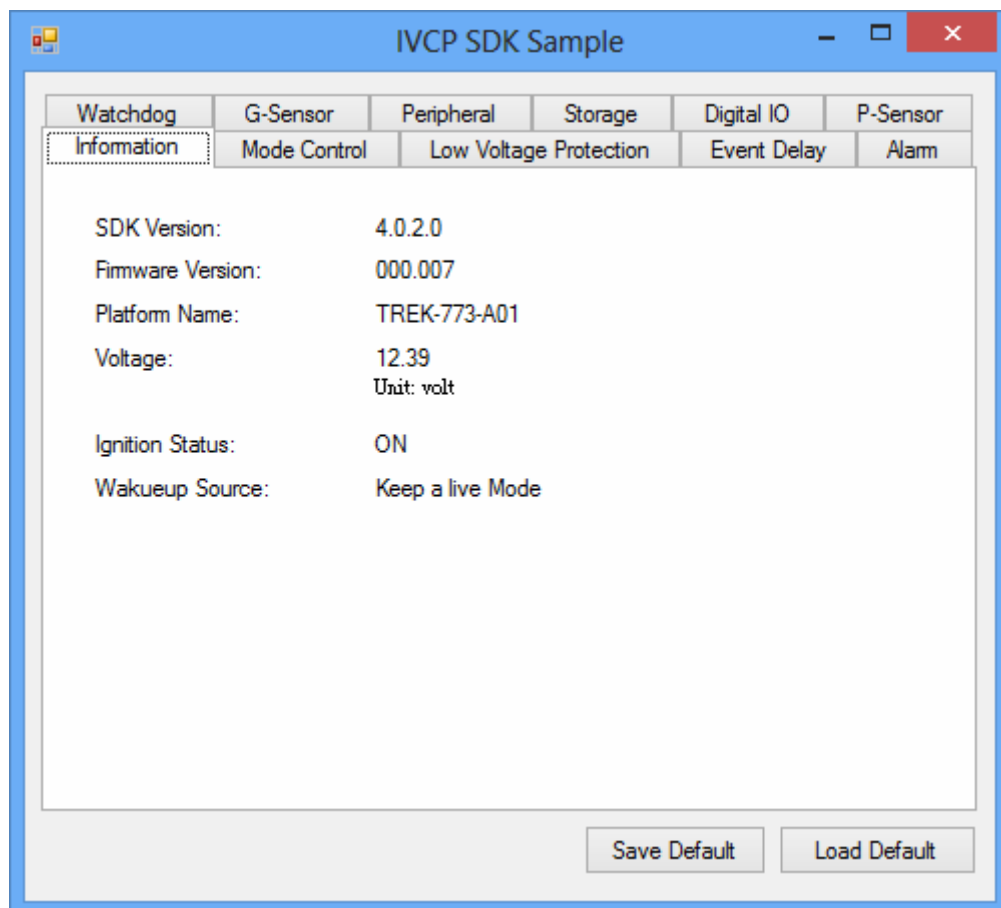

## 4.2.2 Mode Control

In this page, you can toggle “AT Mode” and “Keep Alive Mode”.

Press “Save Default” to set current settings as default value of VPM(Vehicle Power Management) controller.

Press “Load Default” to load the default values.

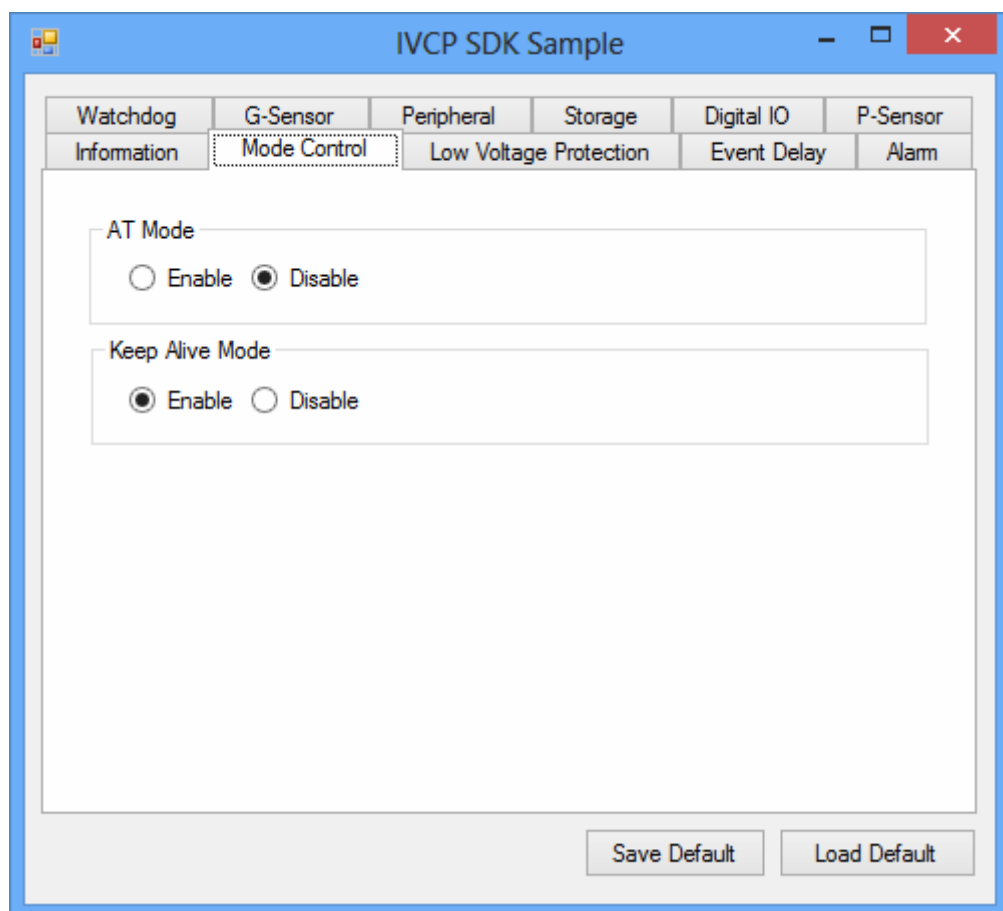

## 4.2.3 Low Voltage Protection

You can enable/disable and set the pre-boot/post-boot low voltage protection threshold in this page.

Press “Get” to get the current threshold value and Press “Set” to set the value.

Press “Save Default” to set current value as default value of VPM controller.

Press “Load Default” to load the stored default values.

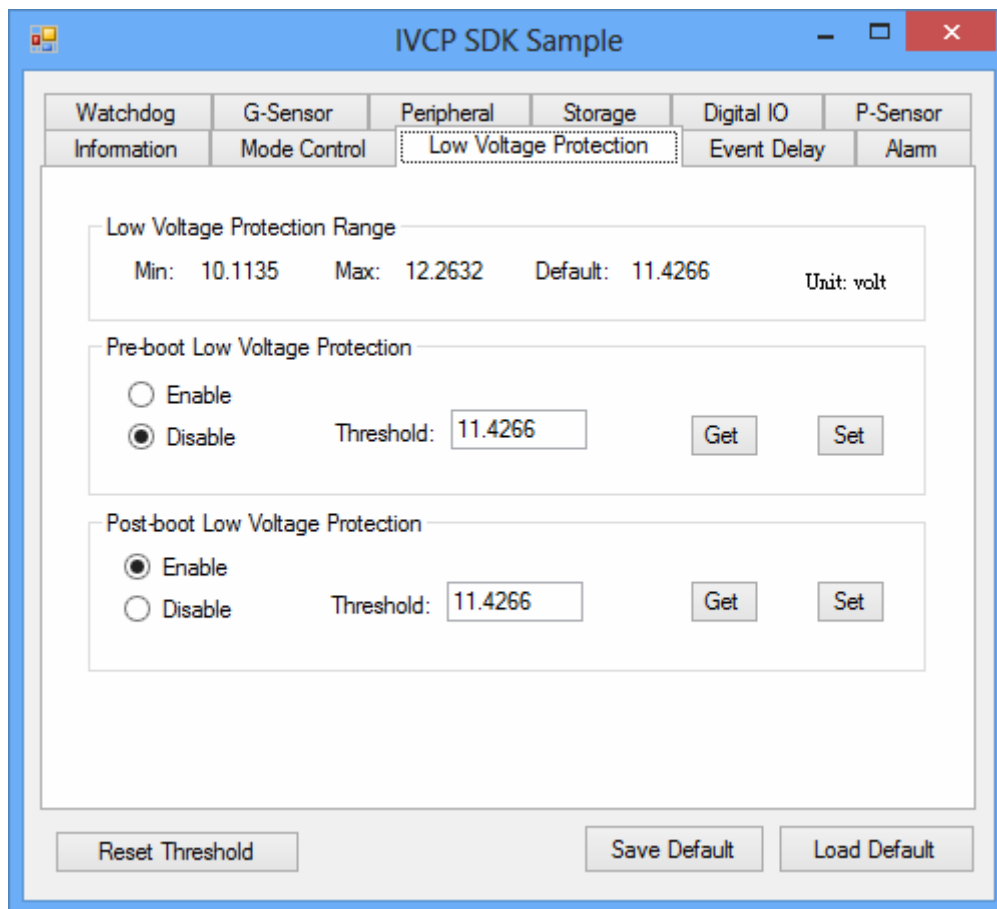

## 4.2.4 Event Delay

### 4.2.4.1 Power control mechanism

TREK-688 provides VPM (Vehicle Power Management) features to fulfill specific requirements. The basic mechanism is shown in the following figure.

## Vehicle Power Management (VPM)

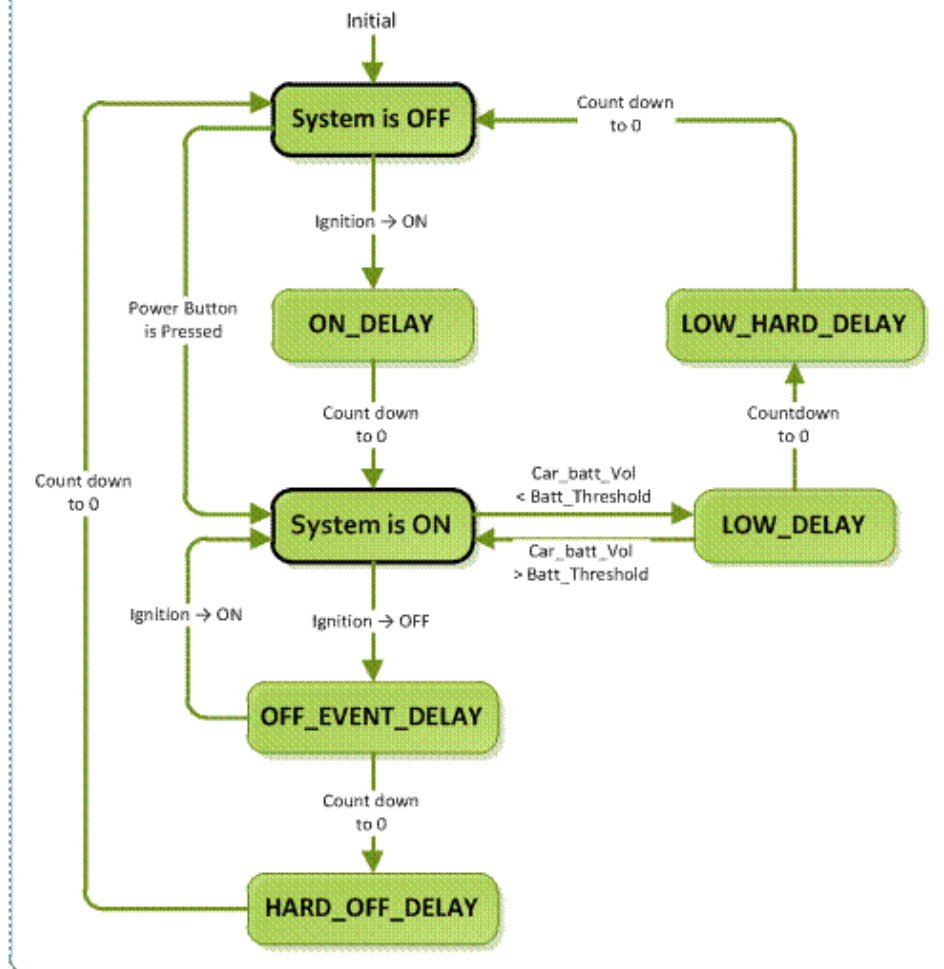

The power of system can be controlled with the following events:

- **Ignition ON**

The ignition signal can be used to power on or shutdown the system. When the system is in an OFF state and the ignition is turned ON, the VPM controller will countdown a delay period (ON\_DELAY). Once it counts to zero, the system will be powered on.

- **Ignition OFF**

When the system is powered on and the ignition is turned off, the VPM controller will countdown a delay period(OFF\_EVENT\_DELAY). During this period, if the ignition

is switched back to ON, the VPM controller will stop countdown and reset the OFF\_EVENT\_DELAY. If OFF\_EVENT\_DELAY counts to zero, the VPM controller will trigger an power off event (i.e. power button press). System and applications which receives this event can do pre-defined tasks, like storing data and preparing to turn off the system.

After the event is triggered, VPM controller starts to countdown next delay period (HARD\_OFF\_DELAY). If HARD\_OFF\_DELAY counts to zero, the system power will be cut off abruptly to avoid unexpected

---

system hang. Also, once VPM controller enter the HARD\_OFF\_DELAY stage, the process cannot be reversed.

- **Low power protection**

To avoid draining power, low-power protection is to ensure that there is enough power

to start the machine. When the system is ON, the VPM controller will monitor the power voltage. If the voltage is lower than the programmable threshold (LOW\_THRESHOLD), the VPM controller will start to countdown a delay(LOW\_DELAY). During the stage of LOW\_DELAY countdown, if voltage

goes back above LOW\_THRESHOLD, the VPM controller will stop counting

down and exit.

If LOW\_DELAY counts to zero, the VPM controller will trigger an power off event (i.e. power button press) and starts to countdown next delay period (LOW\_HARD\_DELAY). If LOW\_HARD\_DELAY counts to zero, the system power will be cut off abruptly to avoid draining the power.

#### 4.2.4.2 Demonstration

You can set the delay and hard delay time of the low voltage event and ignition event.

##### Low Voltage Event

- **Delay:**

The delay time before VPM trigger a power off event (i.e. power button press).

- **Hard Delay:**

The delay time counted down after a power off event is triggered. VPM will force power off the machine if the hard delay time is counted down to zero.

##### Ignition Event

- **On Delay:**

The delay time before VPM trigger an power on event (power on the machine).

- **Off Delay:**

The delay time before VPM trigger an power off event (i.e. power button press).

- **Hard Off Delay:**

The delay time counted after an power off event is triggered. VPM will force power off the machine if the hard delay time is counted down to zero.

Press "Save Default" to set current value as default value.

Press "Load Default" to load the stored default values.

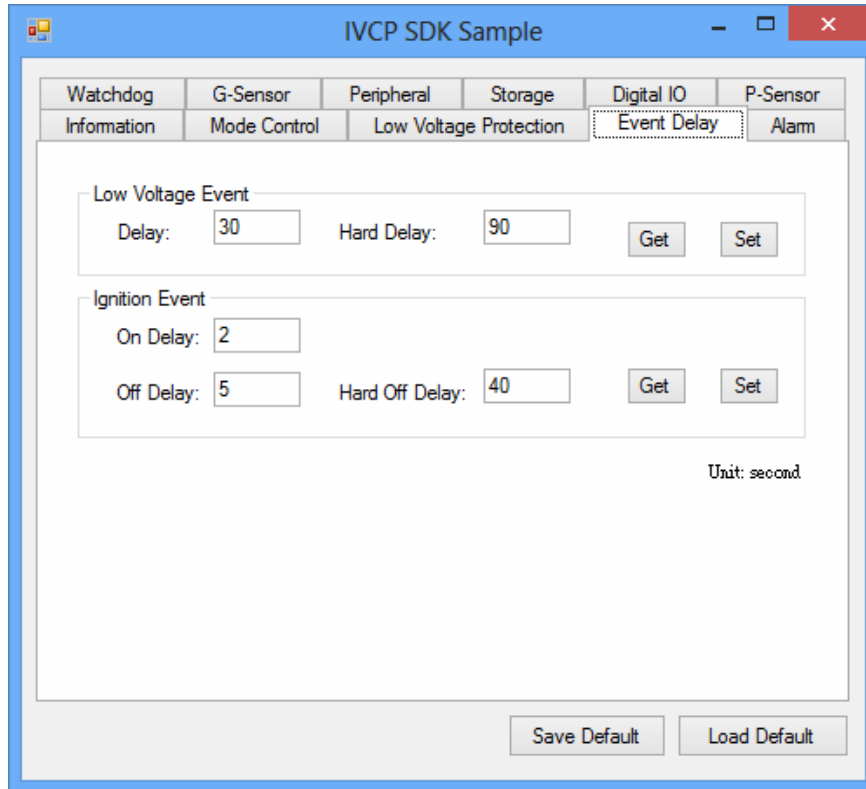

## 4.2.5 Alarm

In this page, you can set the time and set alarm wakeup time to VPM controller and enable/disable the alarm as a system wakeup source.

Press "Save Default" to set current value as default value.

Press "Load Default" to load the stored default values.

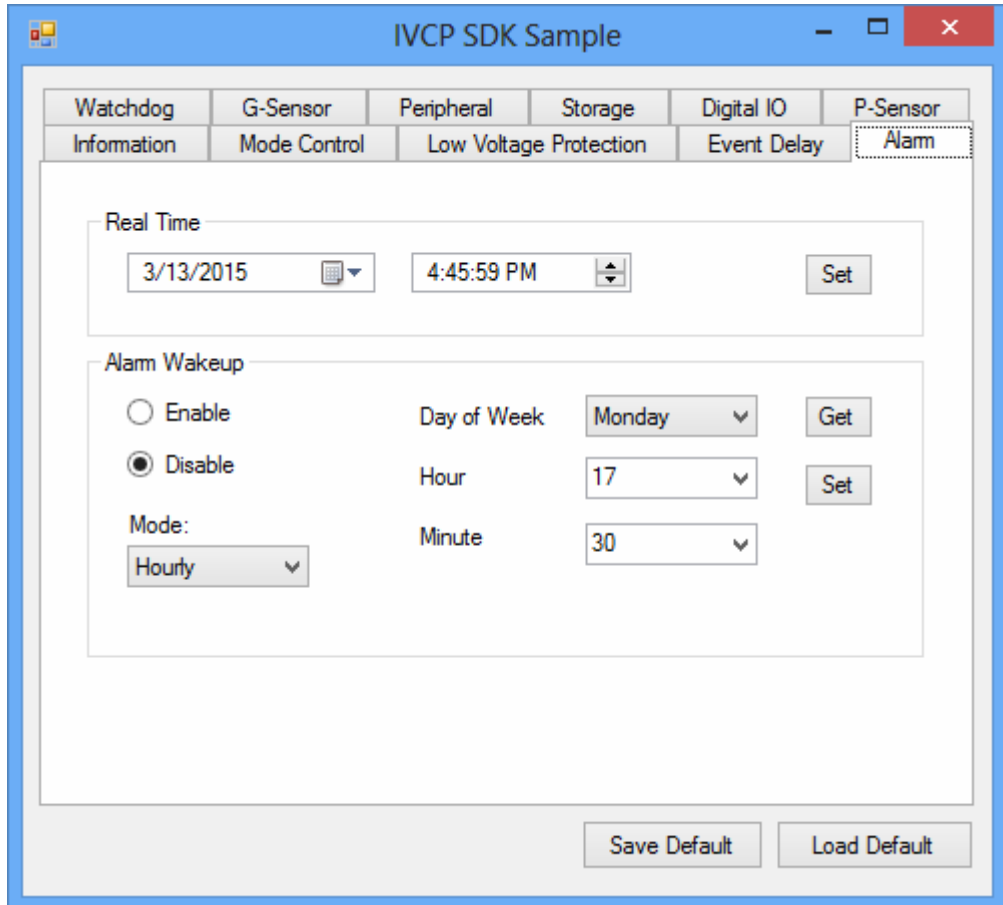

## 4.2.6 Watchdog

In this page, you can enable/disable the watchdog function and set the count time (second) for the watchdog to avoid unexpected system hang..

When watchdog is enabled, the VPM controller will start counting down the time set for watchdog and power off the machine if it is counted to 0. You can press "Trigger" button while watchdog is counting to reset the count down time and keep it counting.

Press "Save Default" to set current value as default value.

Press "Load Default" to load the stored default values.

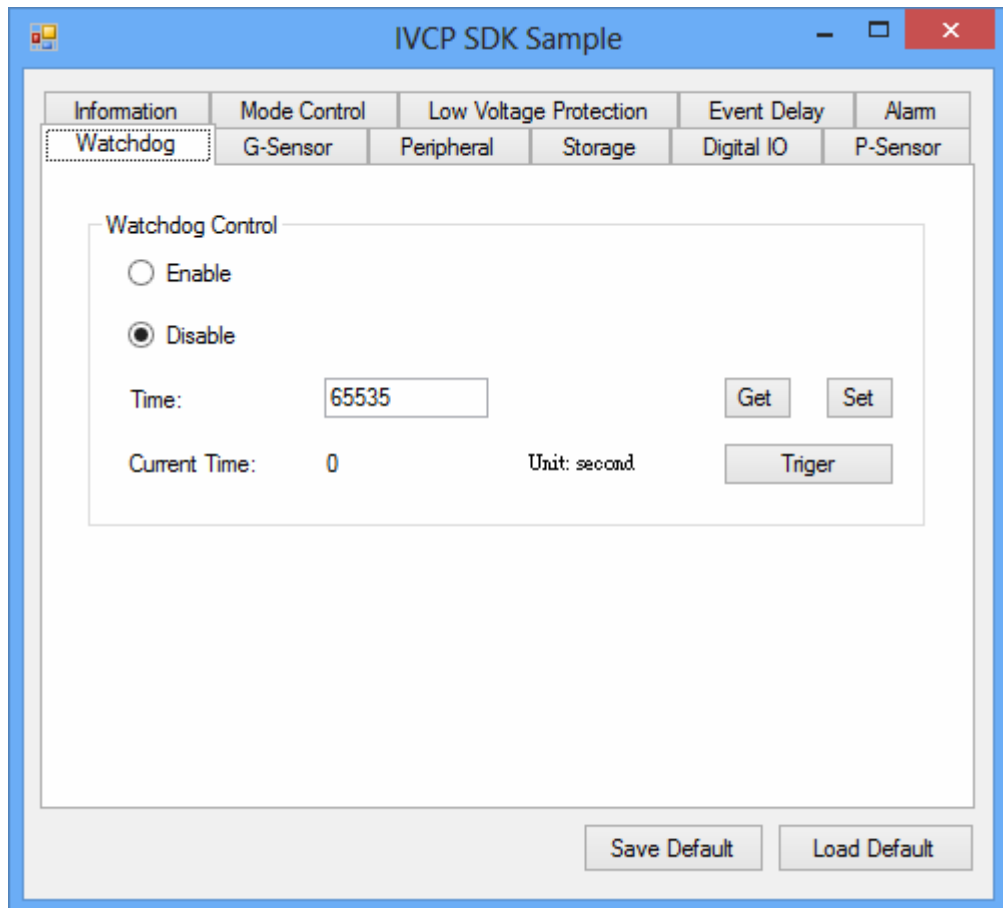

## 4.2.7 G-Sensor

In this page, you can enable/disable the G-sensor. Also, you can set G-sensor as a system wakeup source and set the threshold to trigger system wakeup.



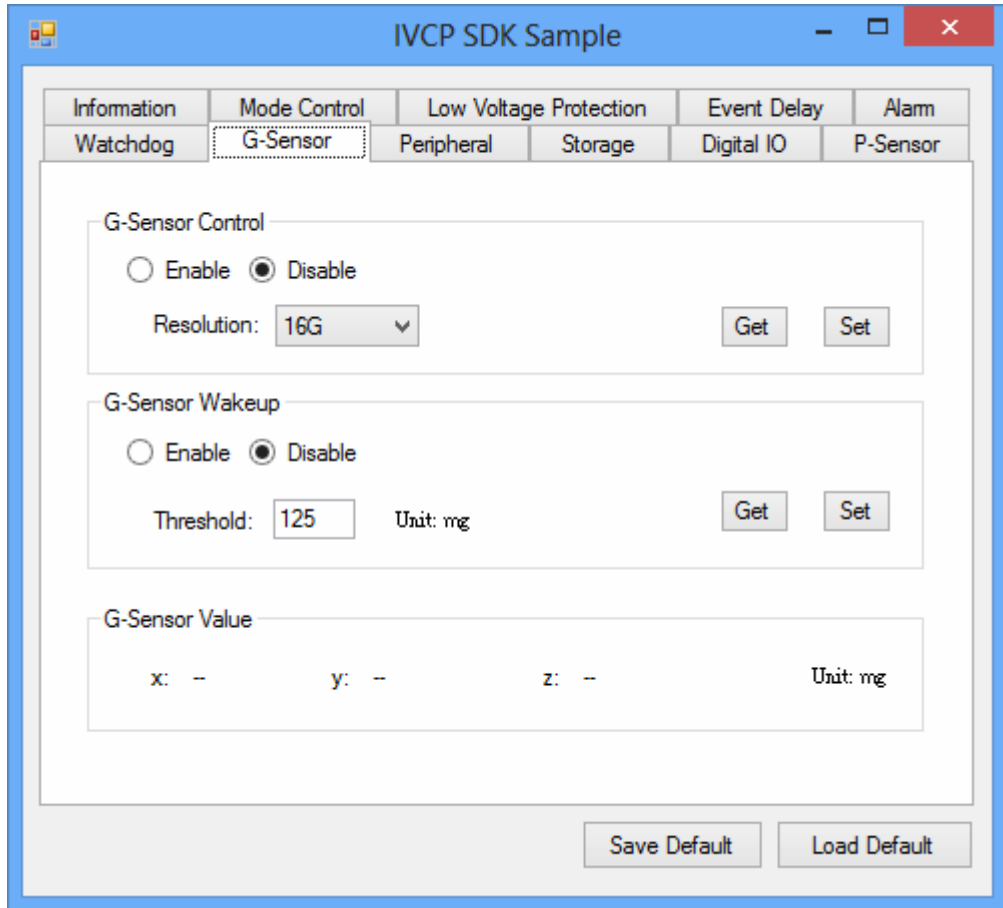

## 4.2.8 Peripheral

In this page, you can enable/disable the peripheral functions and set WWAN as system wakeup source.

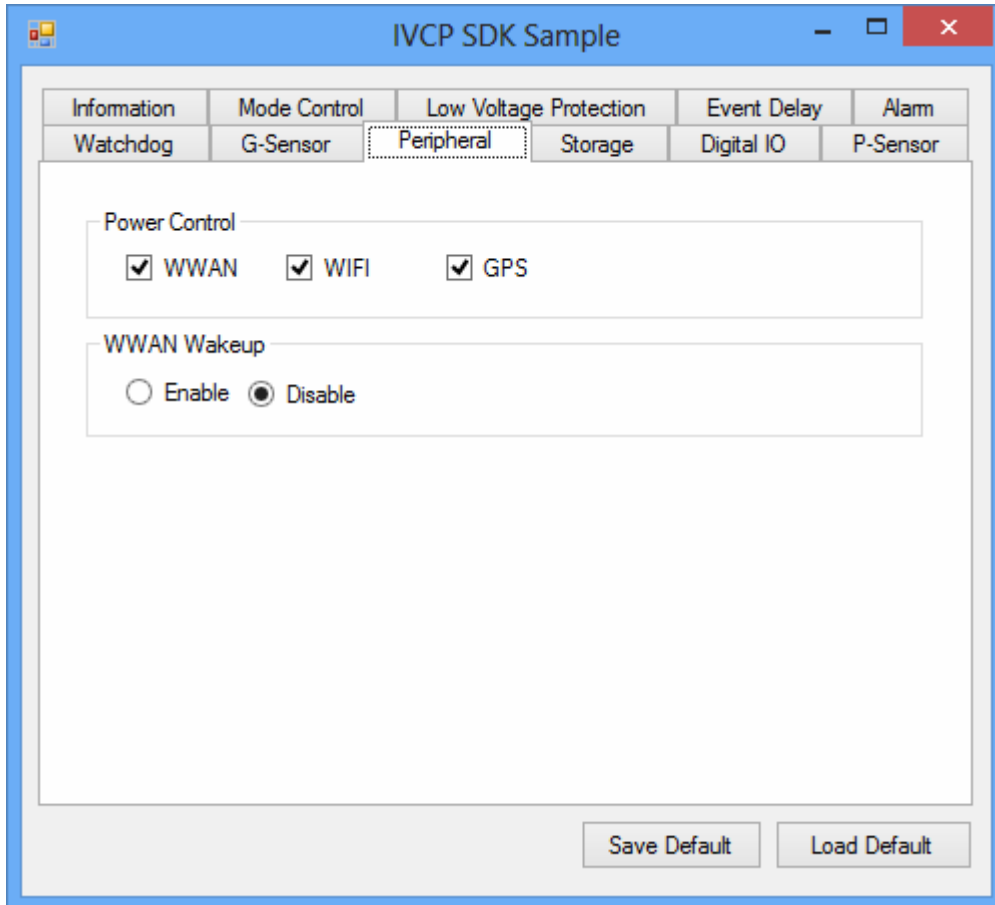

#### 4.2.9 Storage

In this page, you can save/load arbitrary data to the private storage (256 byte) on the machine.

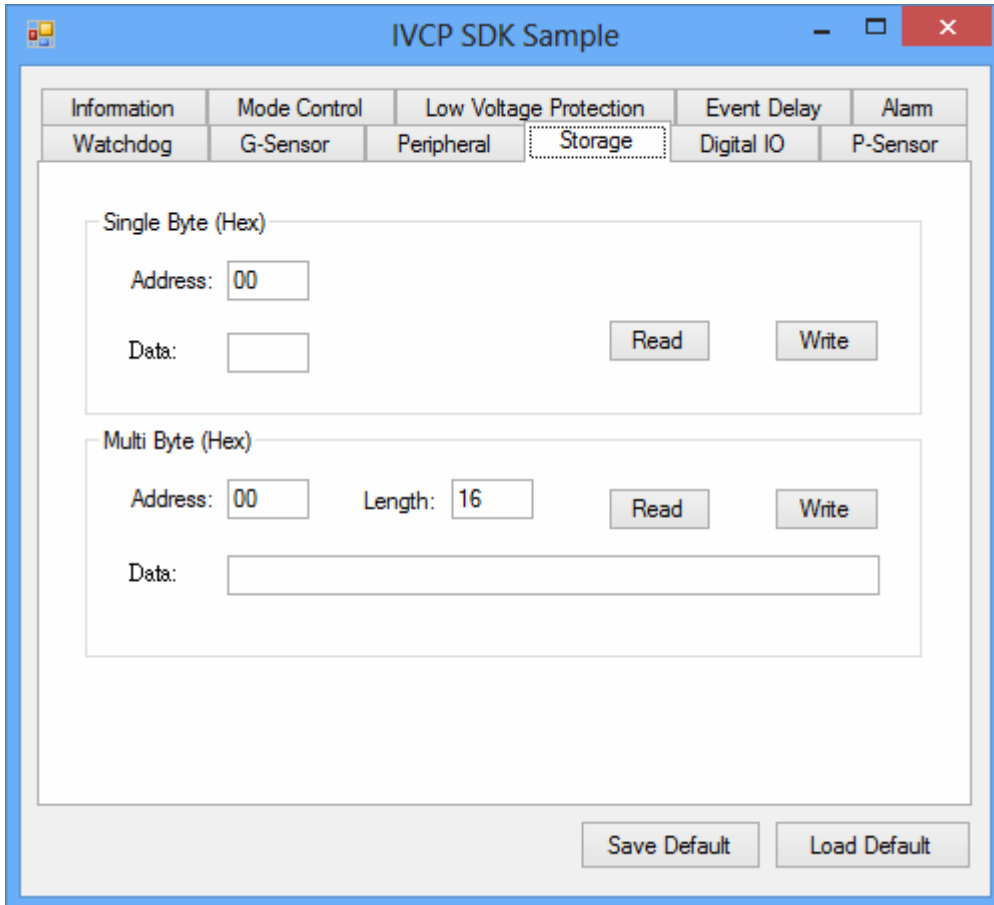

## 4.2.10 Digital I/O

In this page, you can monitor the digital input status and enable/disable digital output.

DI1 default is normal digital input and can be set as dedicated reverse signal input.

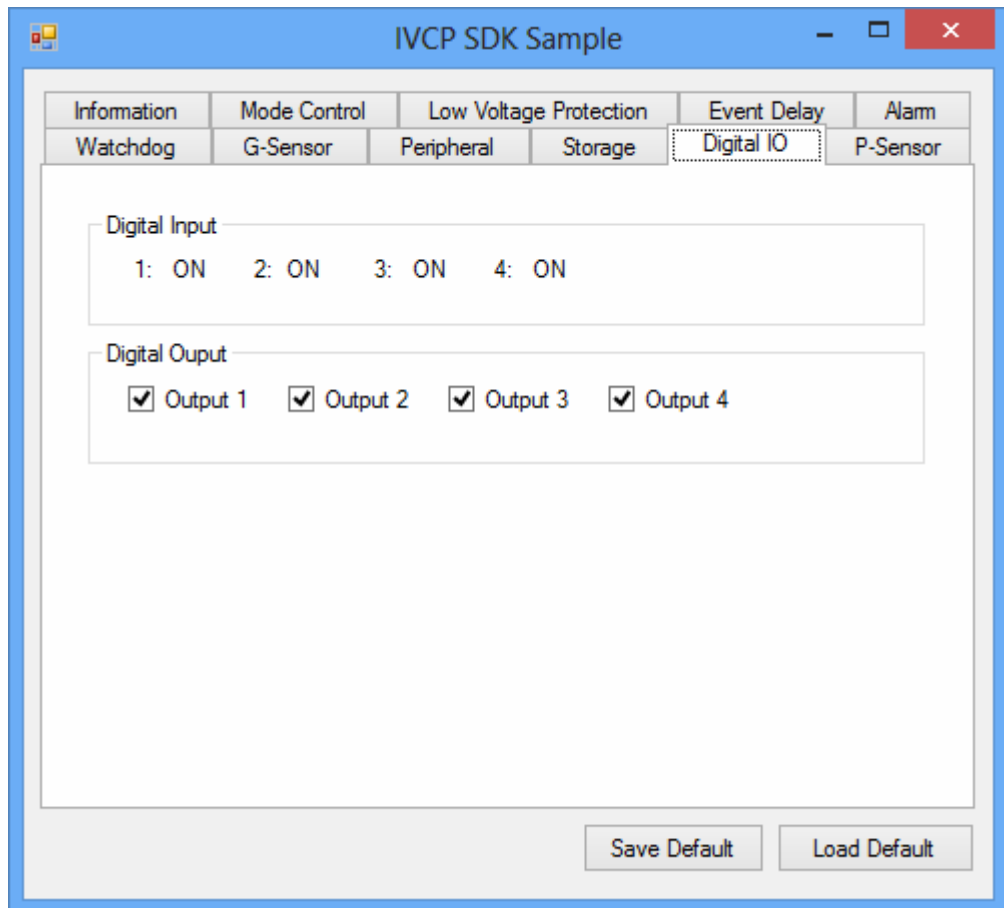

## 4.2.11 P-Sensor

In this page, you can monitor the p-sensor status and enable/disable it.

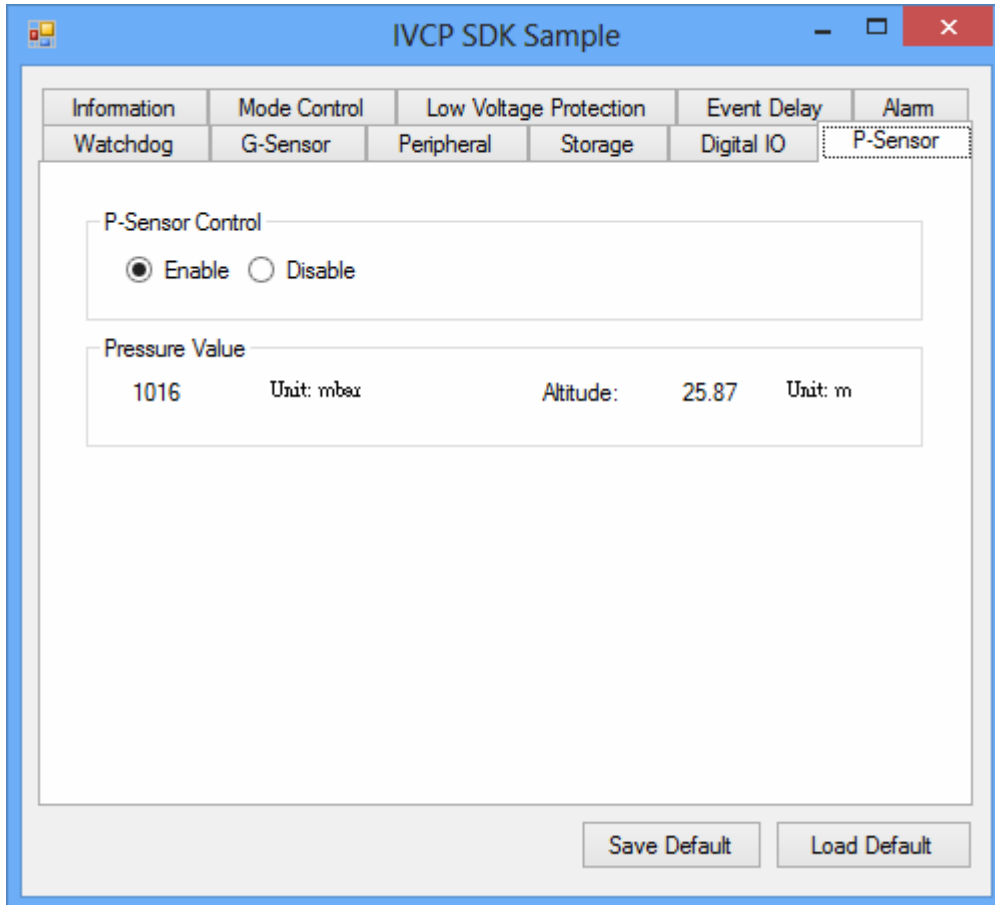

## 4.3 VCIL Demonstration

The VCIL demonstration application demonstrate the usage of MRM VCIL (Vehicle Communication Interface Layer) API which allow user to access vehicle protocol easily.

### 4.3.1 Port selection

When first open VCIL demonstration app, you will see a port selection windows as following.

Please select the VCIL port path and press **Connect** button.

VCIL port path in different platforms have different nodes. The common path at Window is **COM7**.

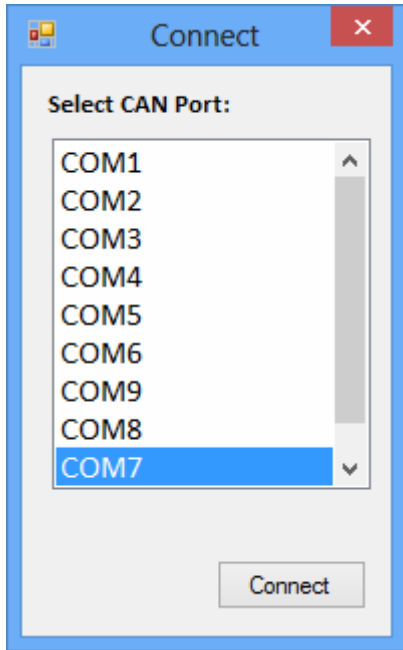

## 4.3.2 Information

In this page, the demo application shows the current status and basic information.

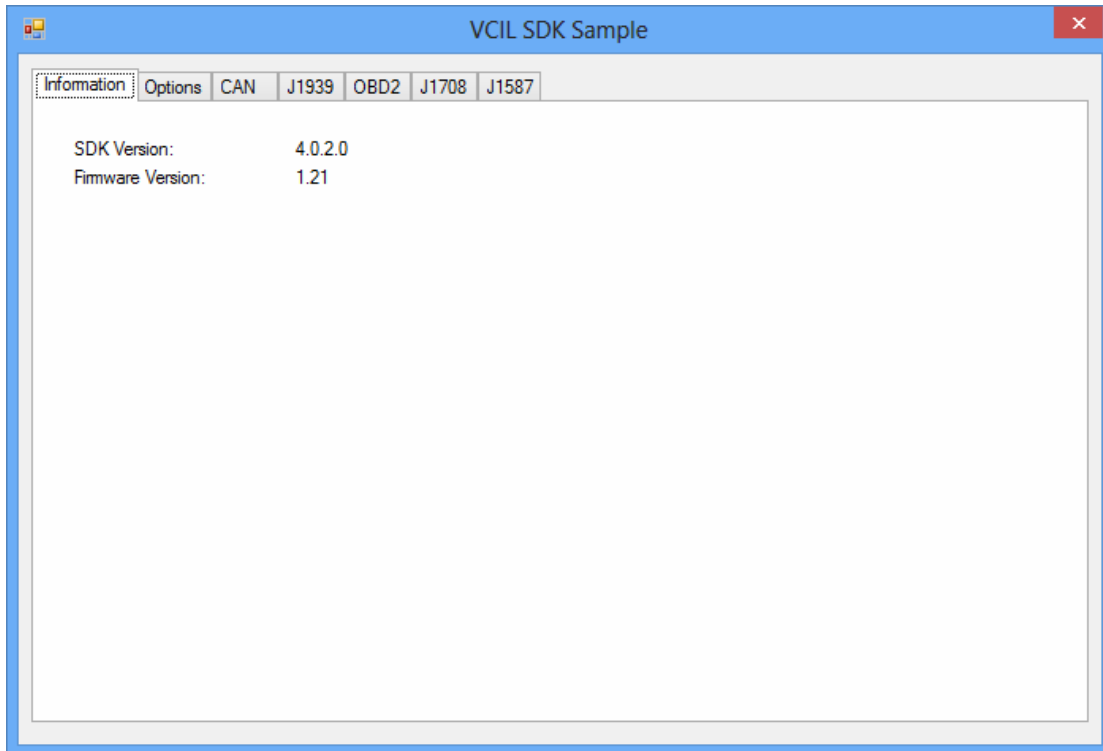

### 4.3.3 Option

In this page, you can the set the protocol for each port.

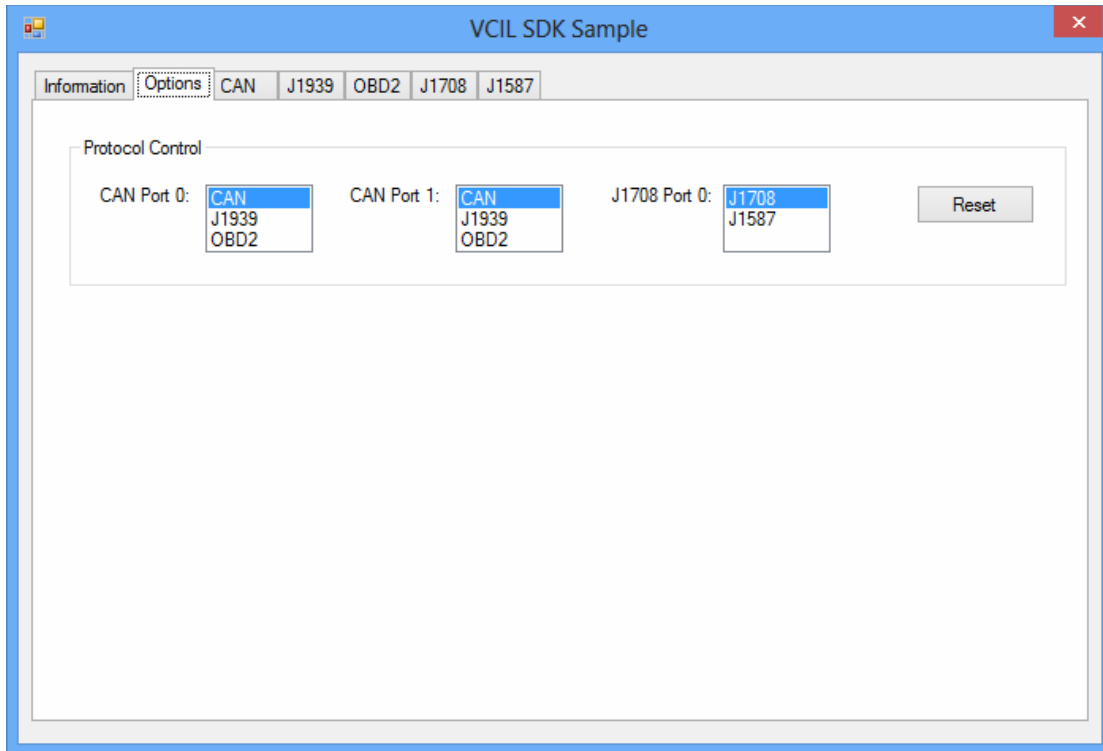



### 4.3.4 CAN / J1939 / OBD2 / J1708 / J1587

To use CAN / J1939 / OBD2 / J1708 / J1587 protocol on each port, please click on corresponding tab to switch to the page of specific protocol, then you can send/read message on specific port by setting the detail items.

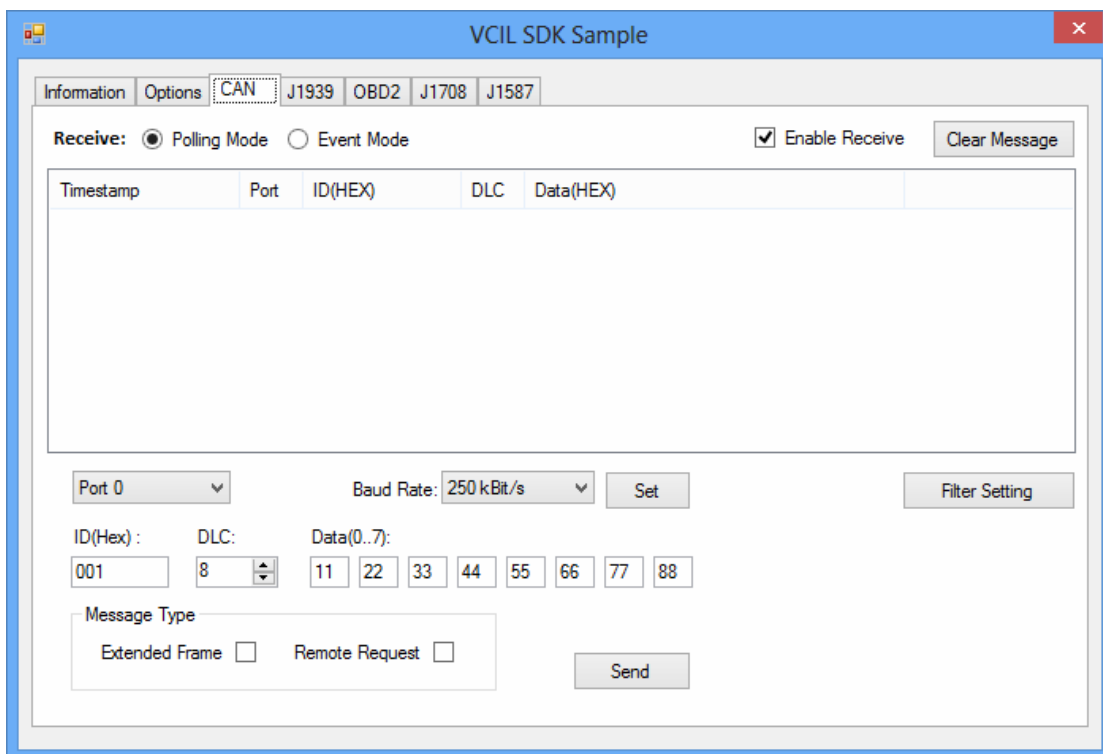

VCIL SDK Sample

Information Options CAN J1939 OBD2 J1708 J1587

Receive:  Polling Mode  Event Mode  Enable Receive

Timestamp	Port	PRI	PGN	DST	SRC	DLC	Data(HEX)

Port 0

PGN(Hex):  DLC:  Data(0..64):

Priority:  Destination:  Source:

VCIL SDK Sample

Information Options CAN J1939 OBD2 J1708 J1587

Receive:  Polling Mode  Event Mode  Enable Receive

Timestamp	Port	PRI	Type	DST	SRC	DLC	Data(HEX)

Port 0

Type:  DLC:  Data(0..64):

Priority:  Destination:  Source:

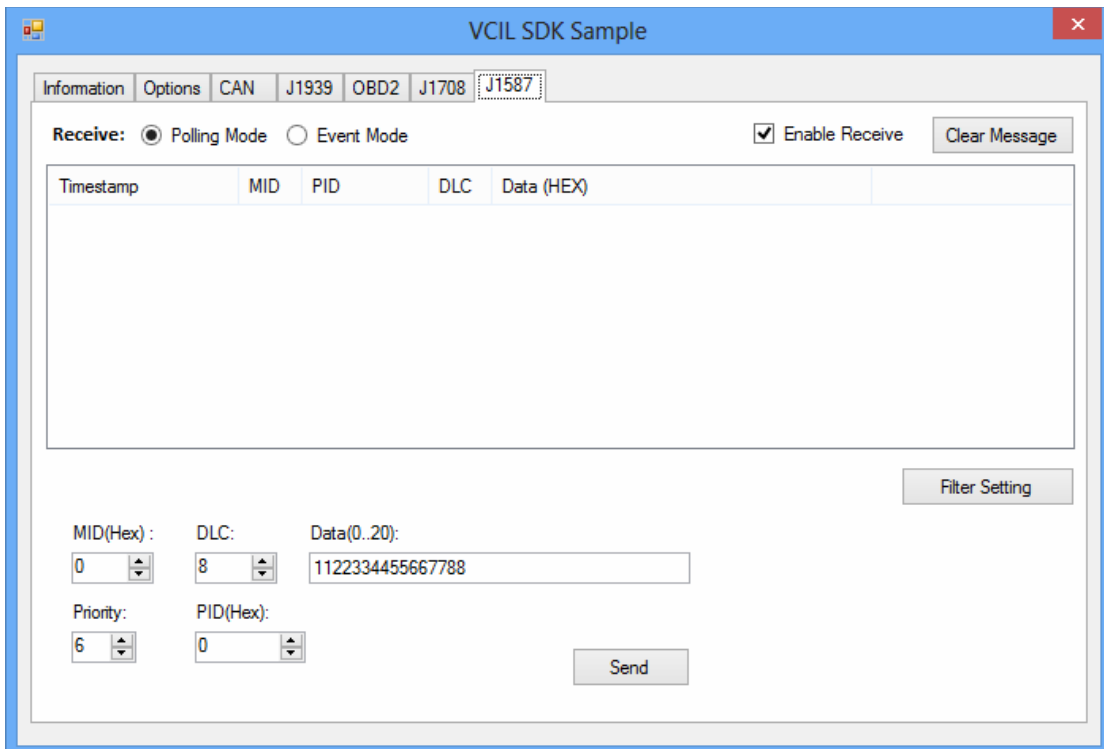
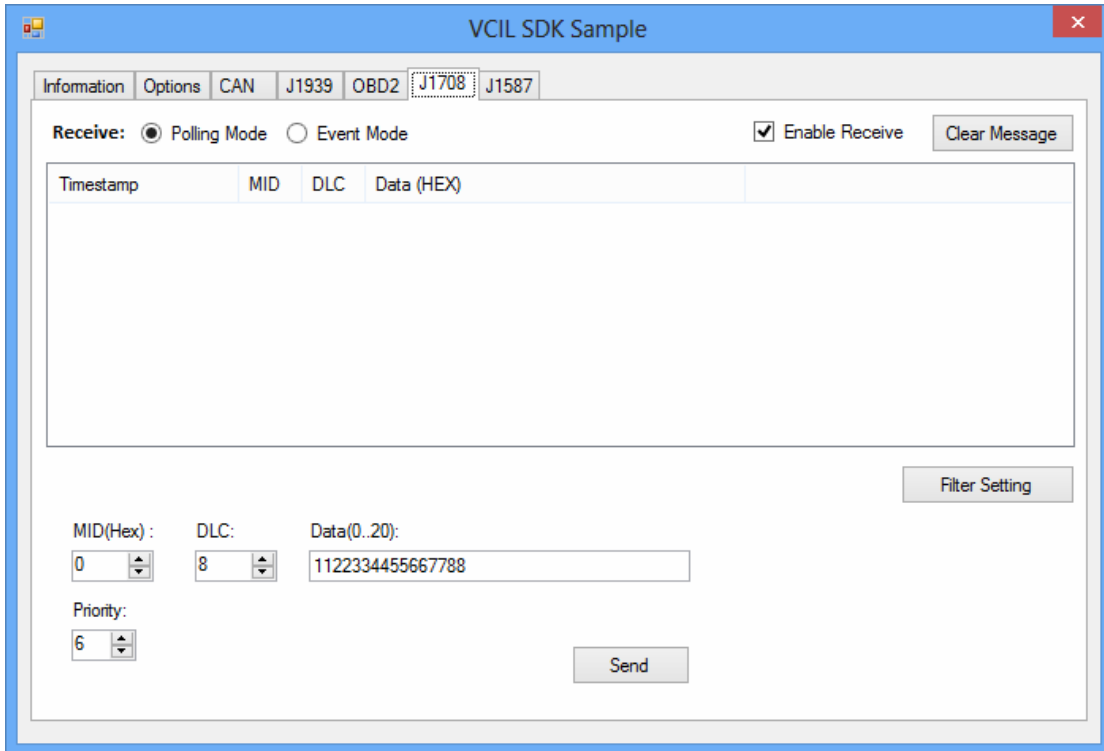

# 4.4 Smart Display Demonstration

The smart display demonstration application demonstrate the usage of MRM SDP API which is a lightweight interface between OS (Operating system) and SDP (Smart Display Co-Processor) allow user to control the font-end display, backlight setting, hotkey, peripheral control, etc.

## 4.4.1 Information

In this page, the demo application shows the current status and basic information.

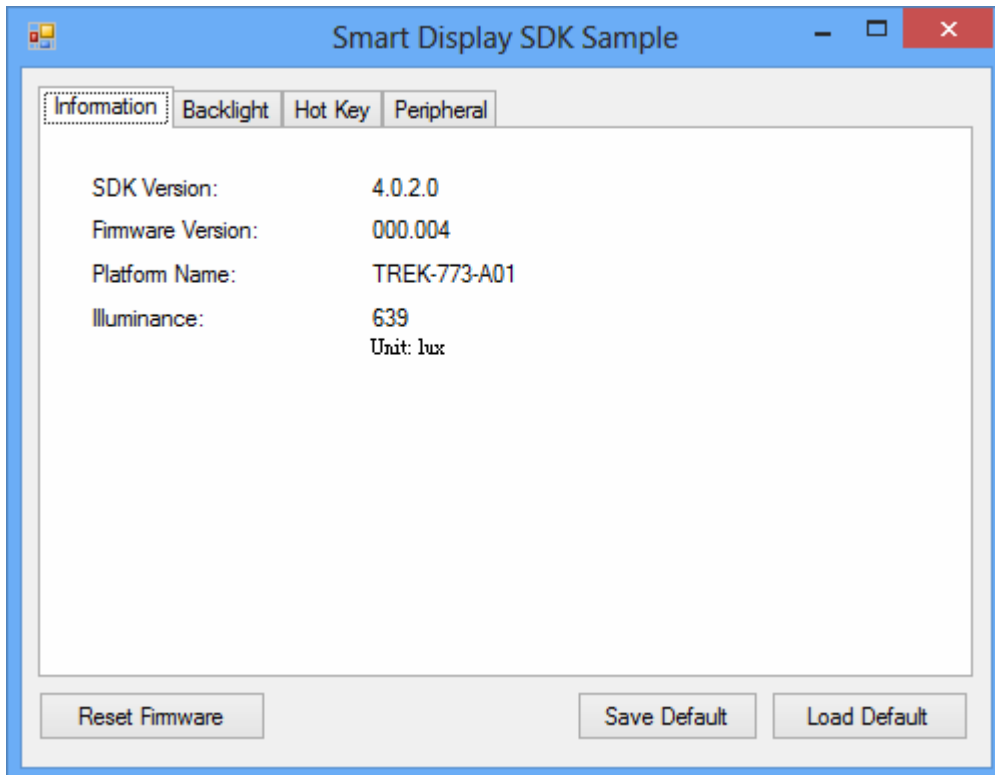

## 4.4.2 Backlight

In this page, you can set the levels for backlight, the brightness for each level and the current brightness level.

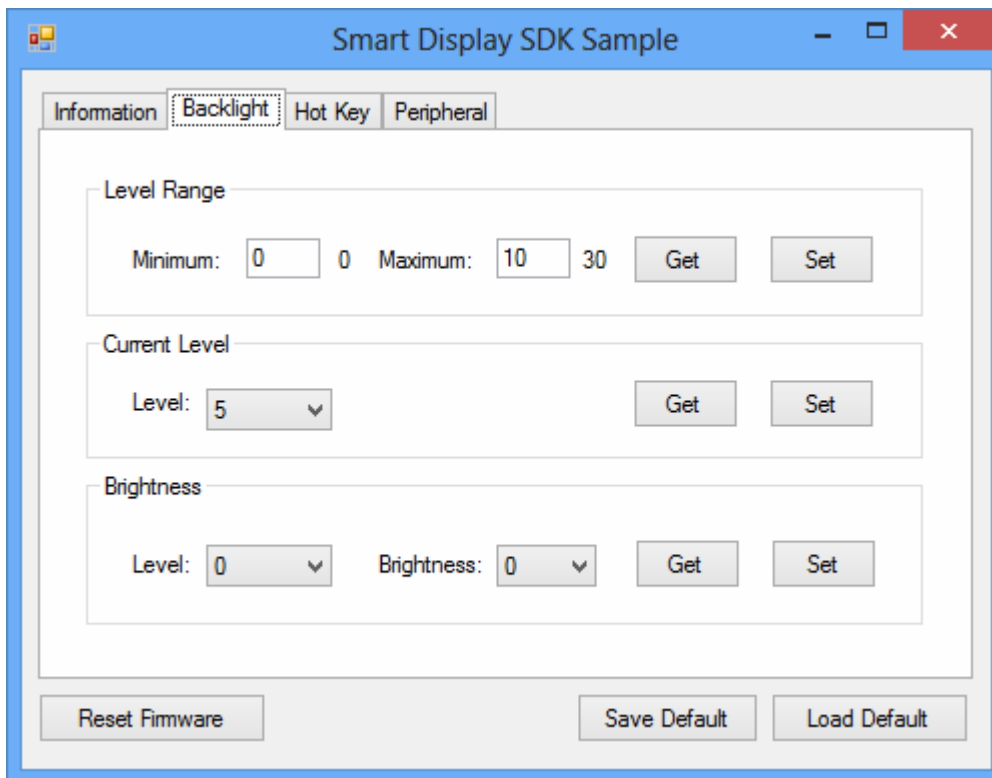

### 4.4.3 Hot key

In this page, you can monitor the press state of each hot key and set the LED brightness of the hot keys.

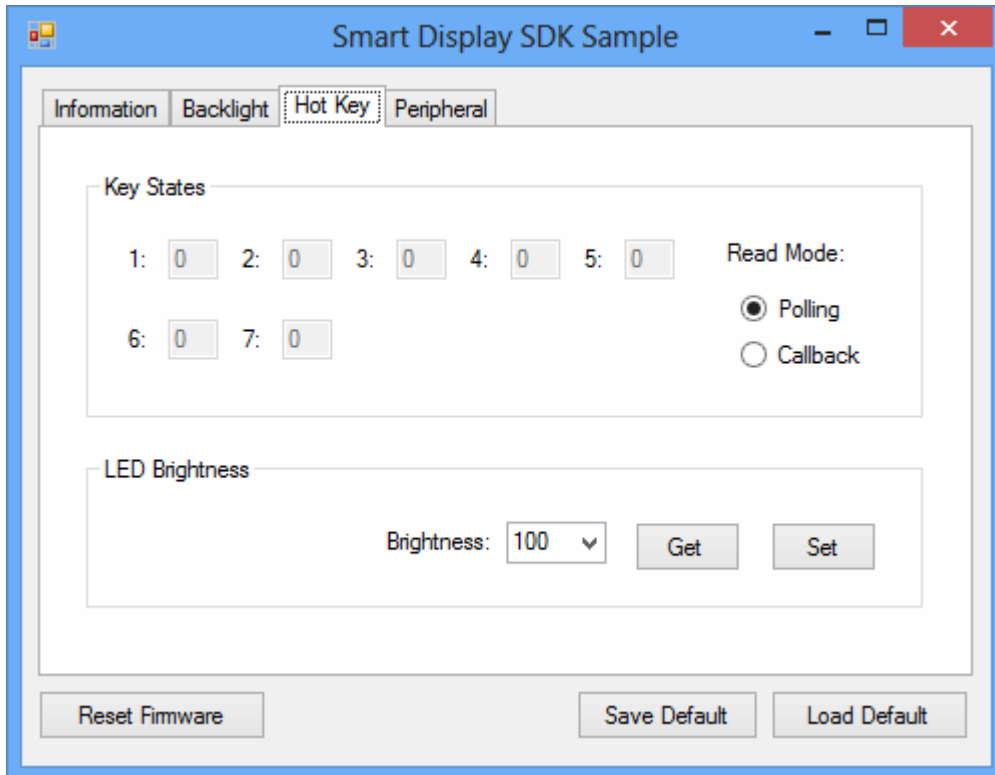

## 4.4.4 Peripheral

In this page, you can control the status of peripheral devices.

- **Speaker**  
Enable/disable speaker volume.
- **Reverse gear**  
Enable/disable auto switch of display. If enabled, the display will be switched to camera view if reverse gear detected and switched to LVDS view if reverse gear absent.
- **USB**  
Enable/disable power of front-end USB port.

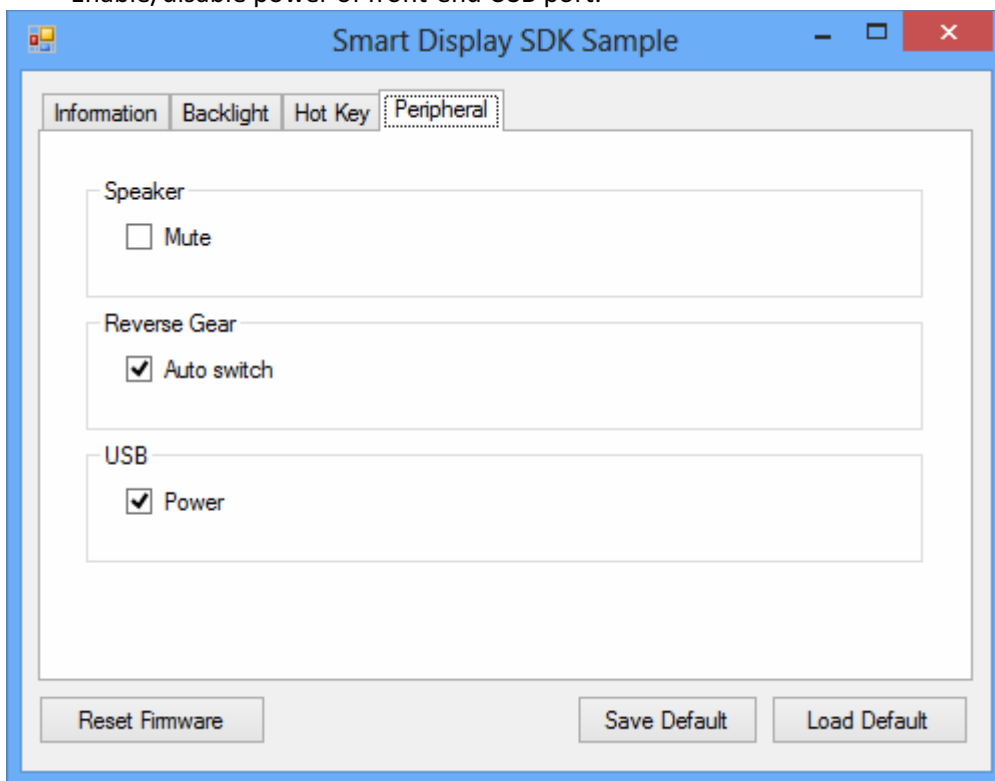

## 4.5 GPS Demonstration

The GPS demonstration application demonstrate the usage of MRM GPS API which is a lightweight interface between OS (Operating system) and GPS module allows user to easily get GPS information.

### 4.5.1 Port selection

When first open GPS demonstration app, you will see a port selection windows as following.

Please select the GPS port path and press **Connect** button. The common path at Window is **COM3**.

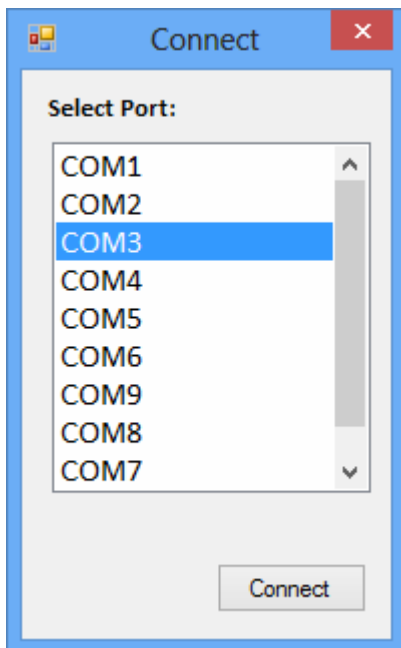



## 4.5.2 Information

In this page, the demo application shows the current GPS status.

1. GPS Status
2. Function demonstration selection
3. Satellite location Information



## 4.5.3 NEMA

In this page, the demo application shows the incoming NMEA code. Check ' Save to file ' to logging the NMEA code to file.

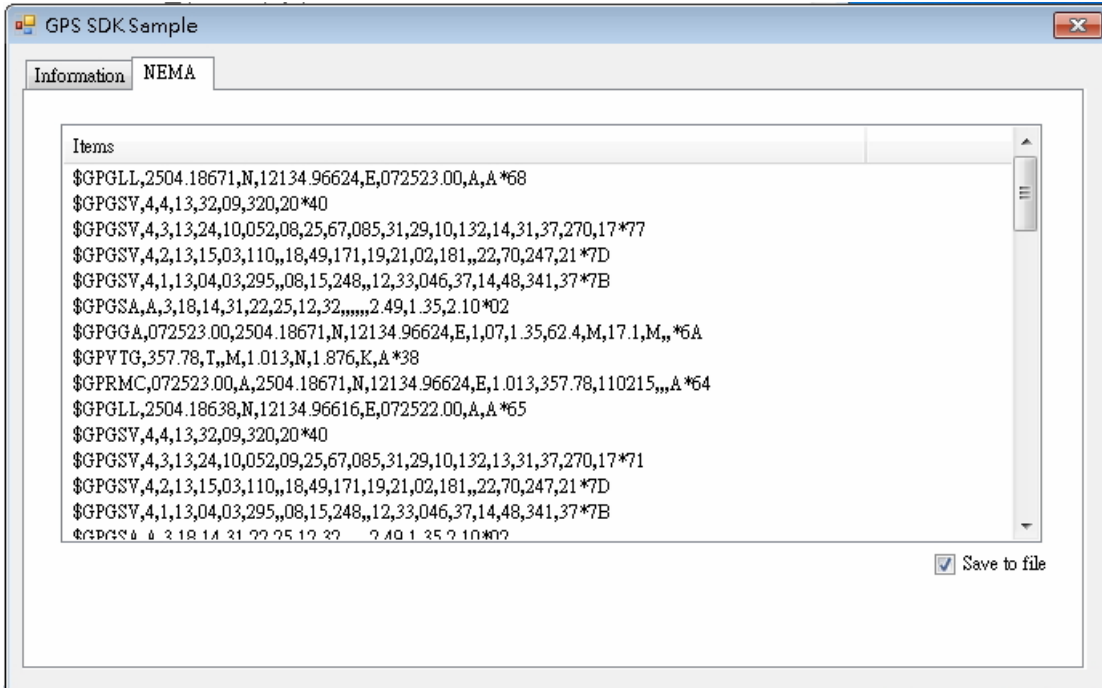

*Trusted ePlatform Services*

**ADVANTECH**

[www.advantech.com](http://www.advantech.com)

Please verify specifications before quoting. This guide is intended for reference purposes only.

All product specifications are subject to change without notice.

No part of this publication may be reproduced in any form or by any means, electronic, photocopying, recording or otherwise, without prior written permission of the publisher.

All brand and product names are trademarks or registered trademarks of their respective companies.

© Advantech Co., Ltd. 2010