

Plug & Play Installation manual

English edition

AGFA Drystar 5300



2923B EN 20031206

- ❖ ***The device must only be operated according to its specifications and its intended use. Any operation not corresponding to the specifications or intended use may result in hazards, which in turn may lead to serious injuries or fatal accidents (for example electric shock). AGFA positively will not assume any liability in these cases.***
- ❖ ***The device must only be installed and put into operation under the specified conditions. For more information about safety, security and use, refer to the Drystar 5300 Reference and User manual.***

For more information on Agfa products and Agfa HealthCare products, please visit www.agfa.com, your Point of Knowledge.

© Agfa-Gevaert N.V. 2003.

No parts of this document may be reproduced, copied, adapted or transmitted in any form or by any means without the written permission of Agfa-Gevaert N.V.

Agfa-Gevaert N.V. makes no warranties or representation, expressed or implied, with respect to the accuracy, completeness or usefulness of the information contained in this document and specifically disclaims warranties of suitability for any particular purpose. Agfa-Gevaert N.V. shall under no circumstances be liable for any damage arising from the use or inability to use any information, apparatus, method or process disclosed in this document.

Agfa-Gevaert N.V. reserves the right to make changes to this document without prior notice.

Agfa-Gevaert N.V., Septestraat 27, B-2640 Mortsel, Belgium.

Drystar 5300 is a trademark of Agfa-Gevaert N.V., Belgium.

Agfa and the Agfa-Rhombus are trademarks of Agfa-Gevaert AG, Germany.

1 Contents of the packages

1 Contents of the packages.



Film pack

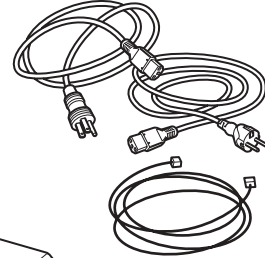

Set of cables

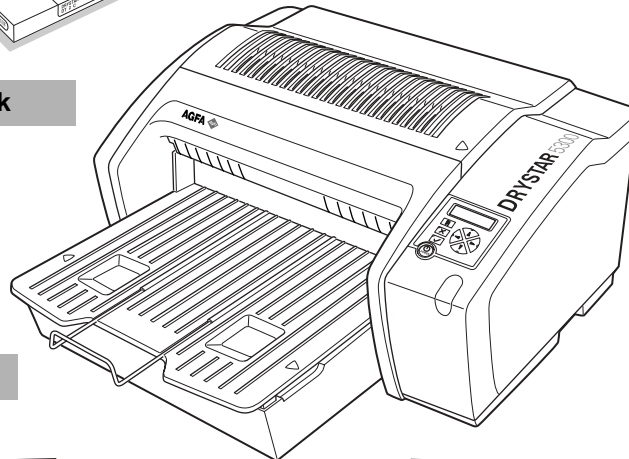

Drystar 5300

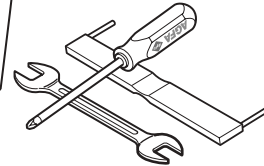

Set of tools

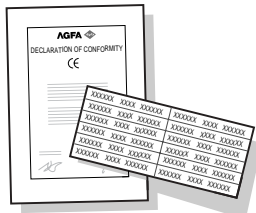

Set of documents

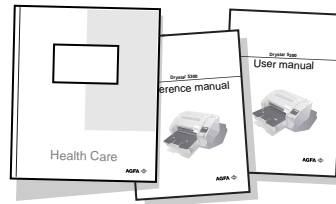

Set of manuals

2 Required tools (included).

Output tray adjustment tool

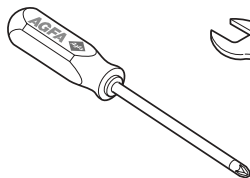

Crosshead screwdriver

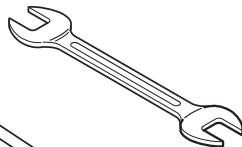

13 mm wrench

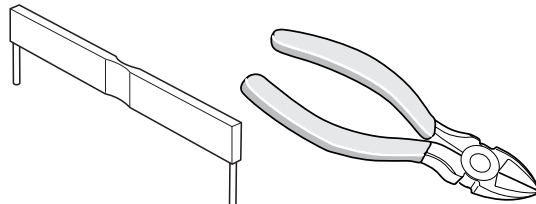

Wire cutter (NOT included)

2 Remove the packing materials

1 Remove the wooden top plate.

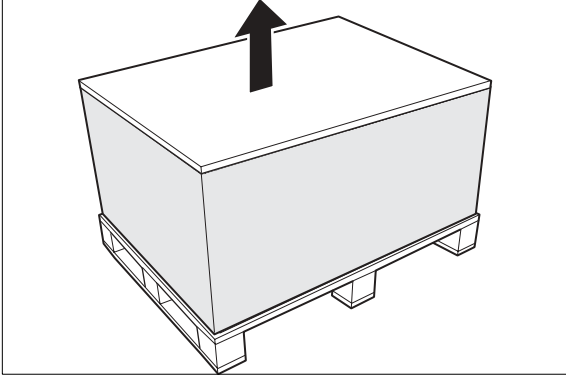

2 Remove the cardboard box.

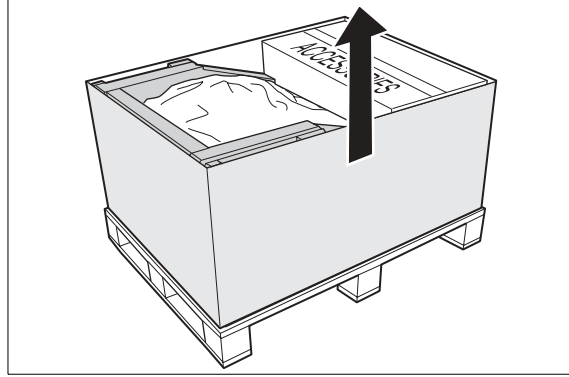

3 Remove the foam blocks.

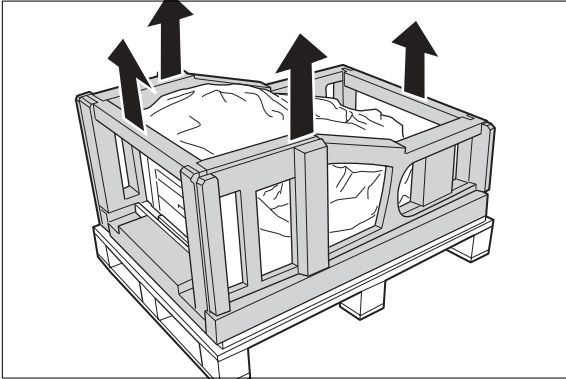

4 Remove the plastic bag.

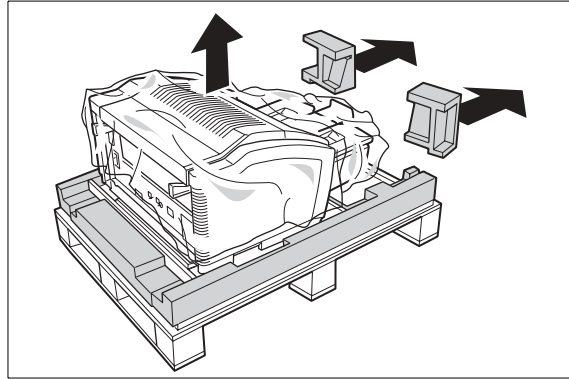

3

Remove Drystar 5300 from pallet

1 Take 13 mm wrench.

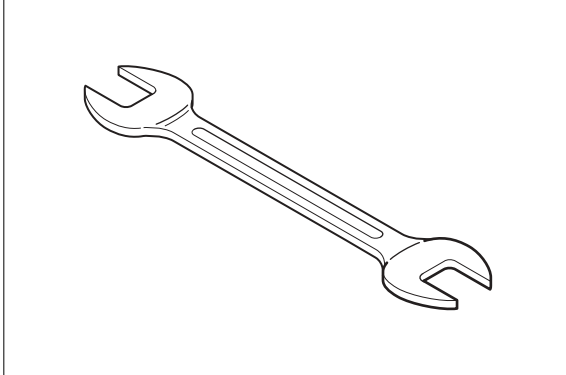

2 Remove 2 screws.

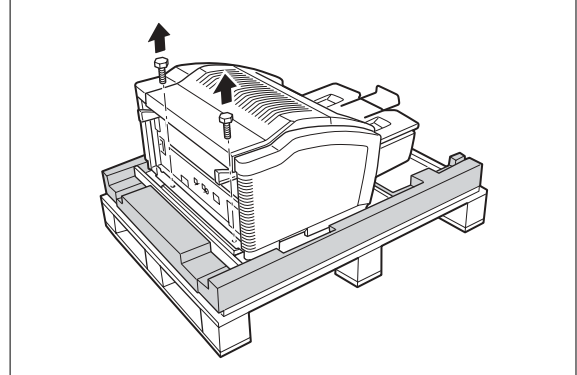

MOBILE or SEISMIC INSTALLATION ONLY:
reuse screws to fix printer at its location.

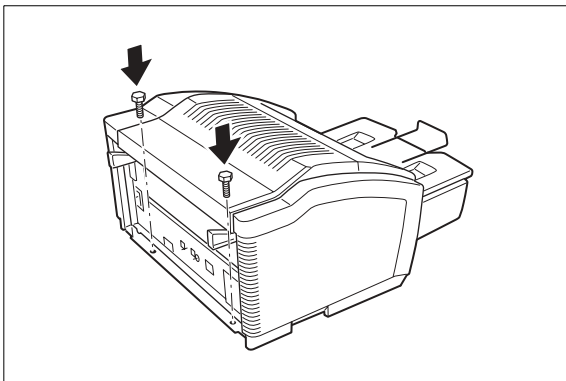

3 Shift printer to the right [1] and lift it from pallet [2].

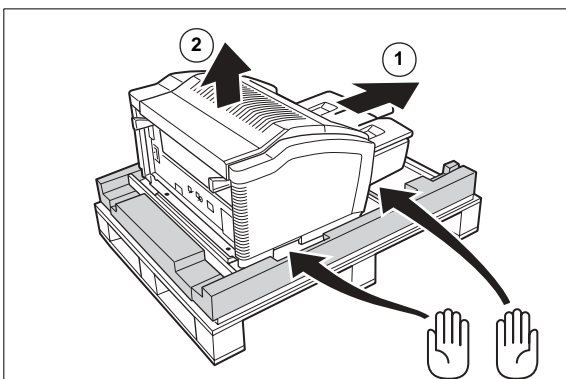

4 Put printer on a table.
Align with the table edge.

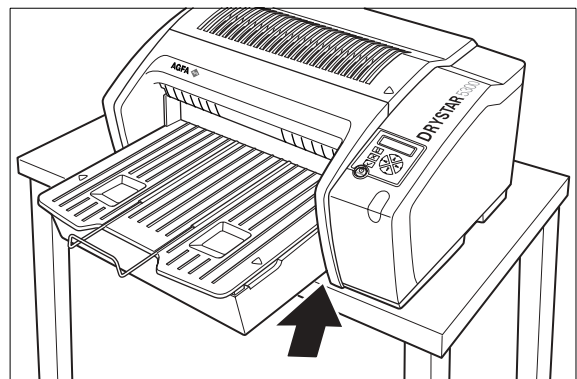

4 Unpack the accessories

1 Check all accessories.

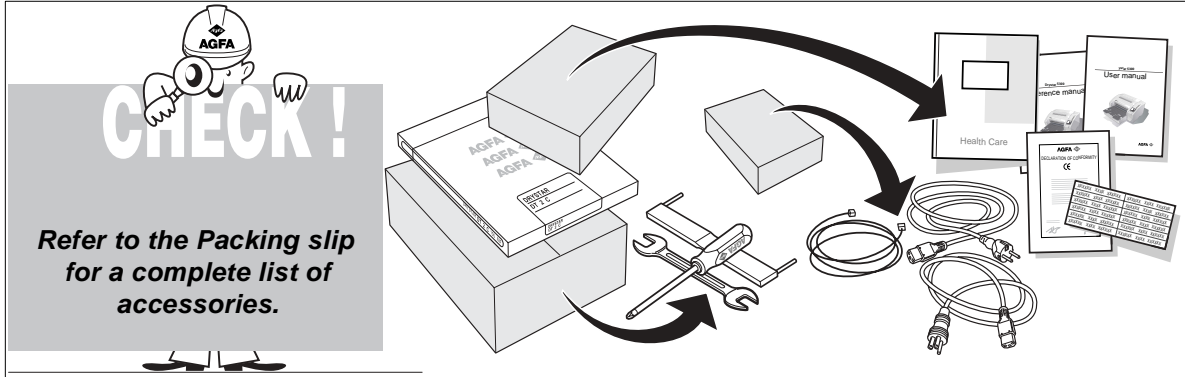

2 Check all documents.

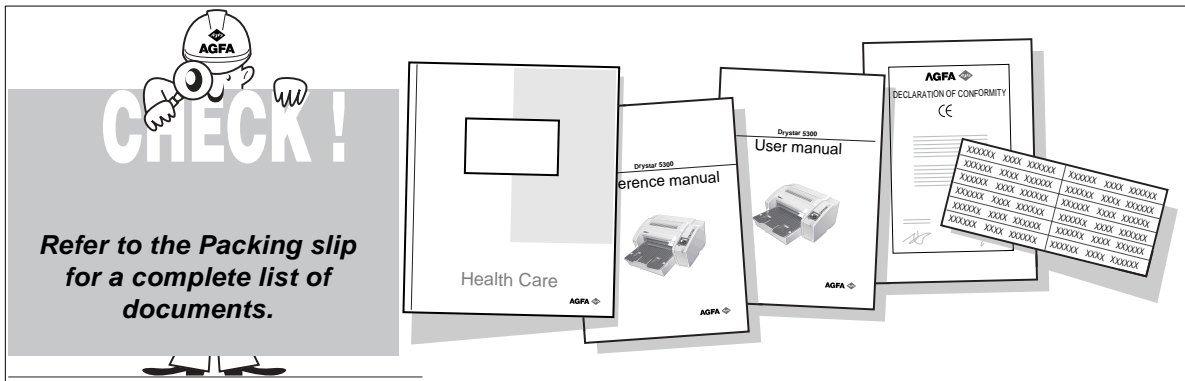

3 Return the packing materials to a recycling service.

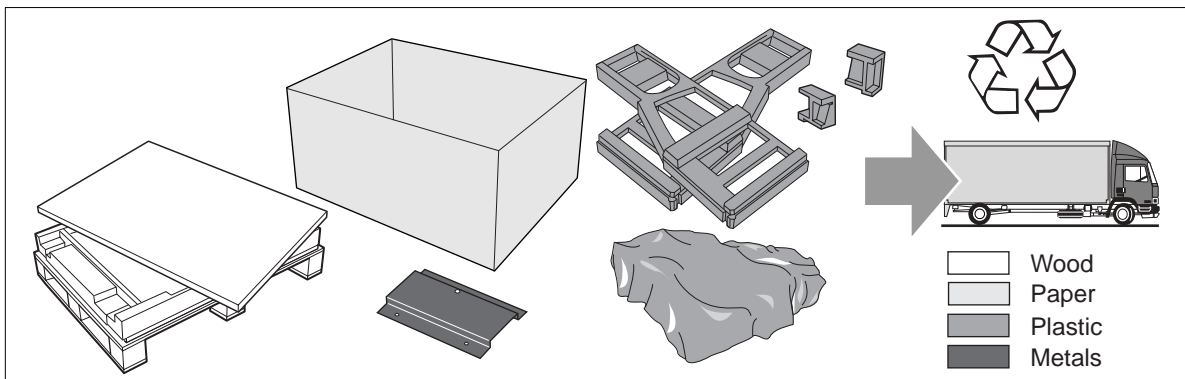

5 Environment specifications

1 Environment requirements.

- ◆ Ventilated room,
- ◆ away from direct sunlight,
- ◆ away from sources of dust, humidity, heat and cold,
- ◆ room temperature between 10°C (50°F) and 30°C (86°F),
- ◆ relative humidity between 10% and 80% non-condensing.

2 Power requirements.

The AC outlet must have either of following specifications:

- ◆ 100-120 V, 60 Hz, 16/15 A,
- or
- ◆ 200-240 V, 50 Hz, 16/15 A.

3 Space requirements.

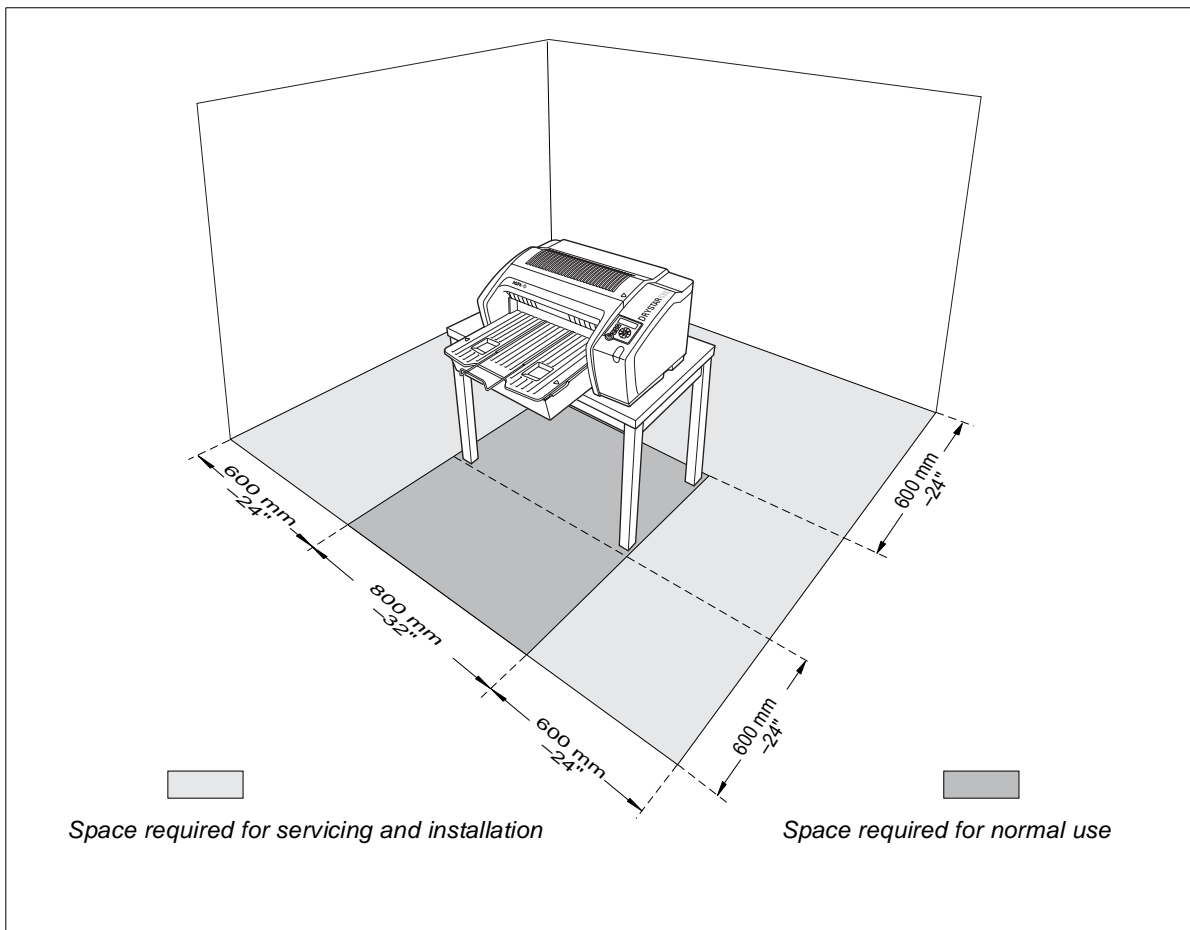

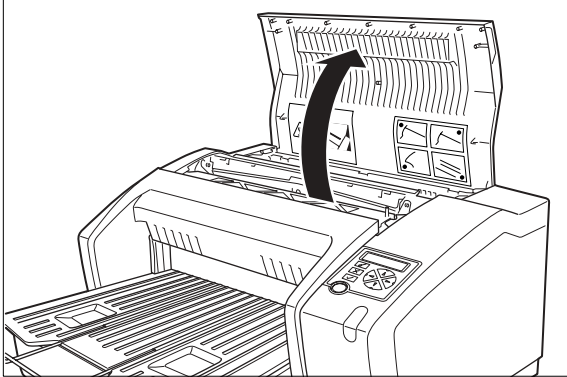
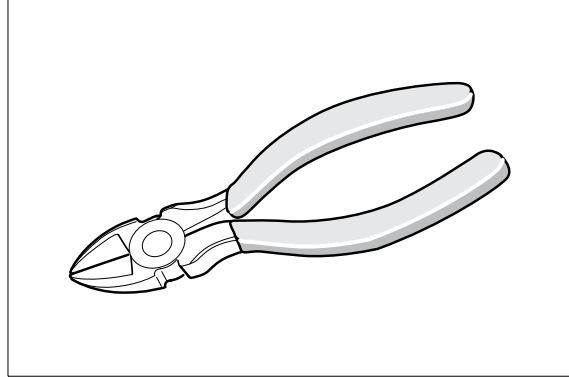
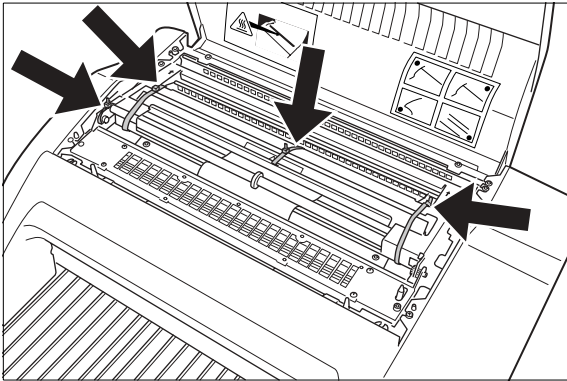
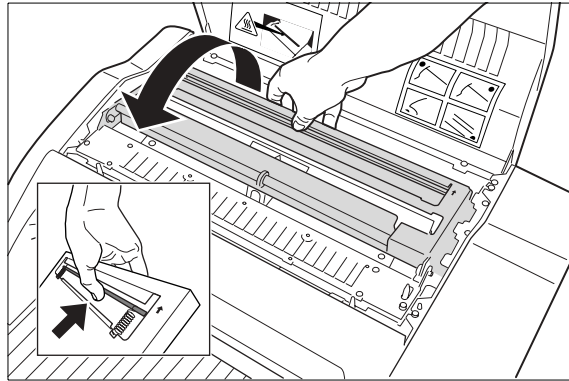
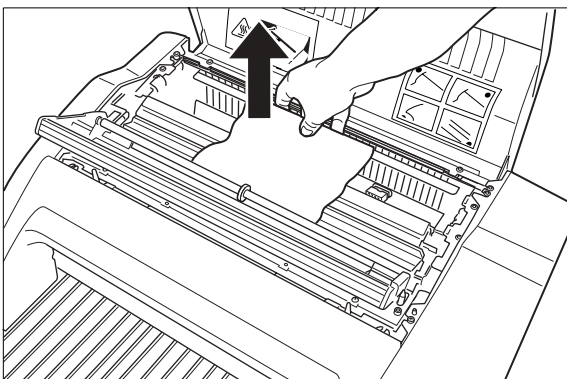
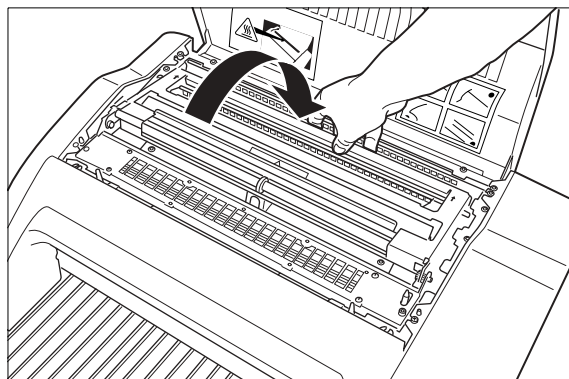
6**Remove transport protections (1 of 2)****1** Open top cover.**2** Take wire cutter.**3** Cut 4 red straps.**4** Open hold-down bracket.**5** Remove foam sheet.**6** Close hold-down bracket.

7 Remove transport protections (2 of 2)

7 Close top cover.

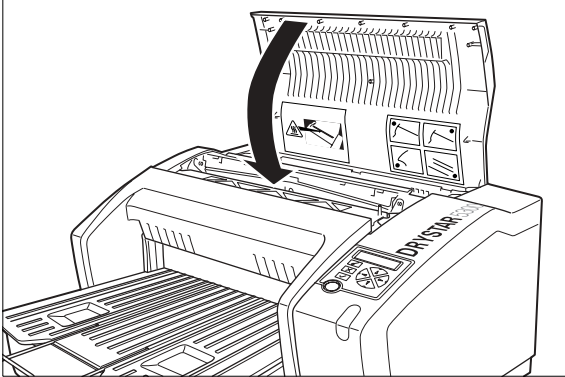

8 Open input tray.

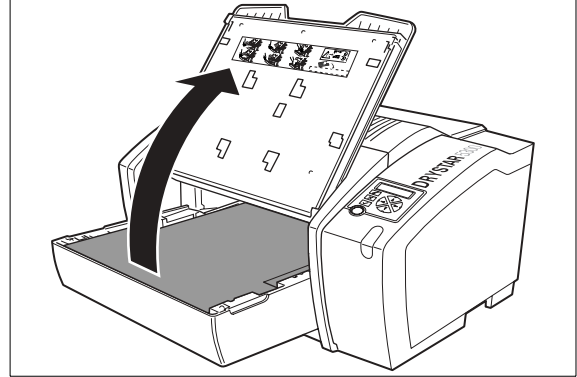

9 Remove foam block from input tray.

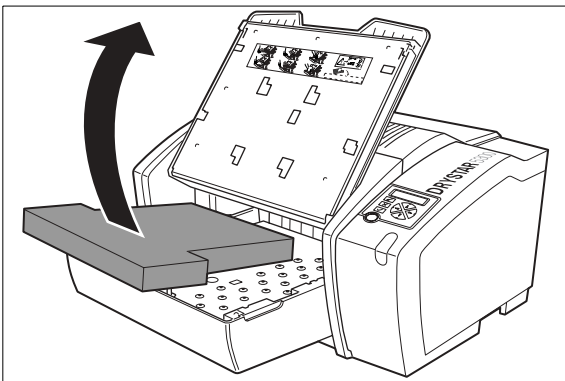

10 Close input tray.

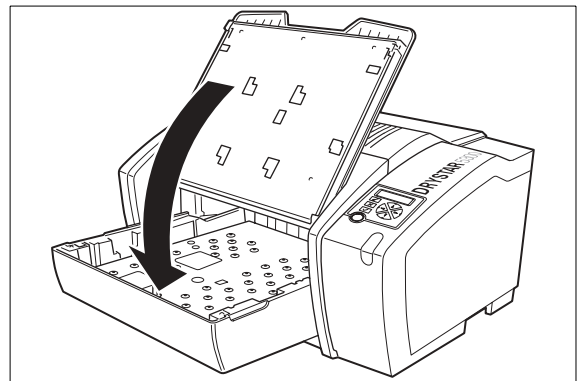

11 Take crosshead screwdriver.

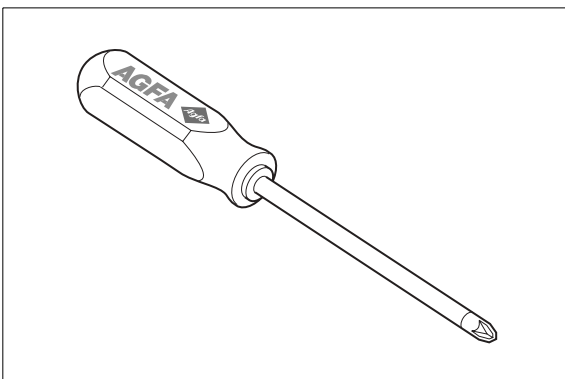

12 Remove drum screw.

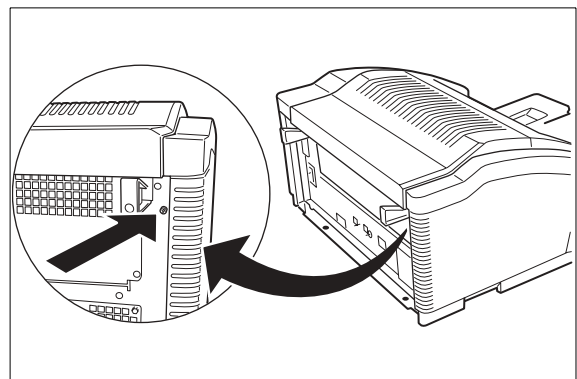

8

Adjust Input block module - 11x14" (1 of 2)

1 Take output tray adjustment tool.

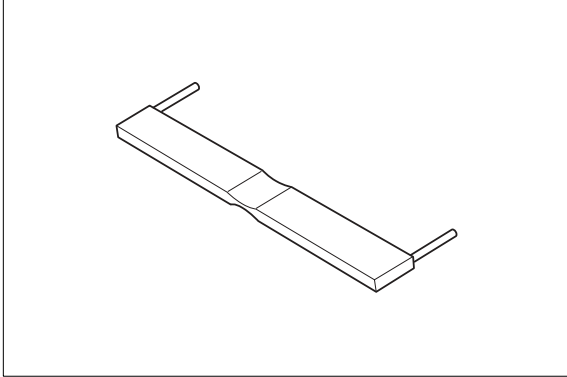

2 Push tool down into output tray holes [1]. Push bracket until it clicks [2].

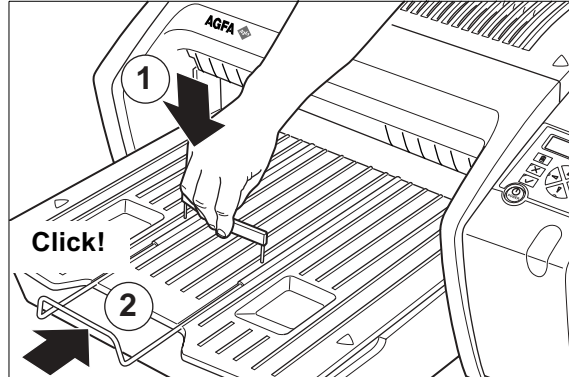

3 Take crosshead screwdriver.

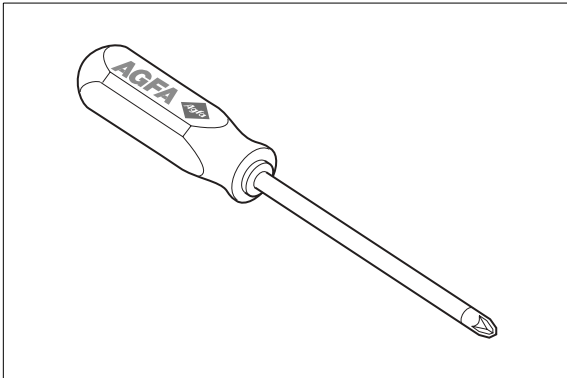

4 Remove 3 screws.

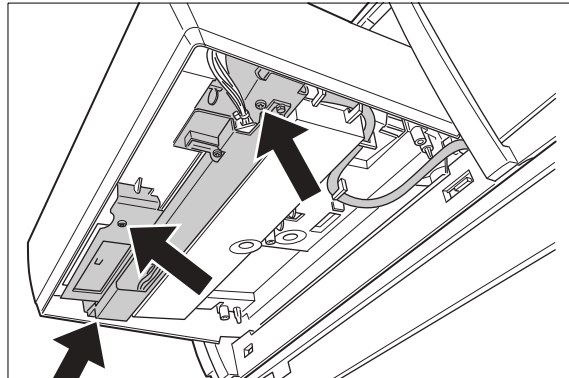

5 Lower film positioner unit.

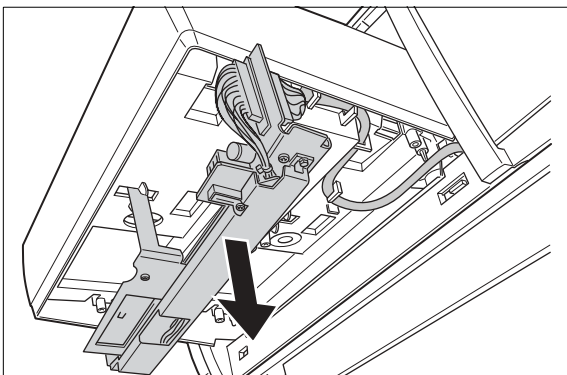

6 Loosen cable.

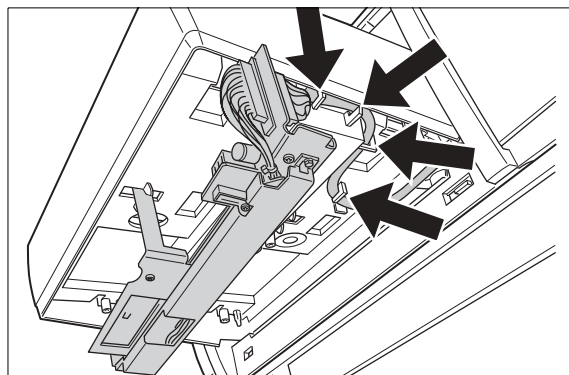

9

Adjust Input block module - 11x14" (2 of 2)

B

Installation

7 Push cable into printer housing.

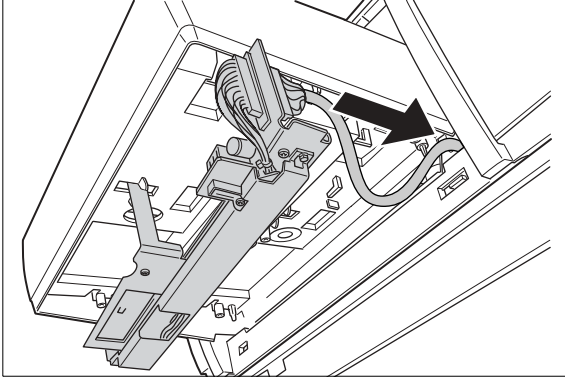

8 Put and hold film positioner unit into place.

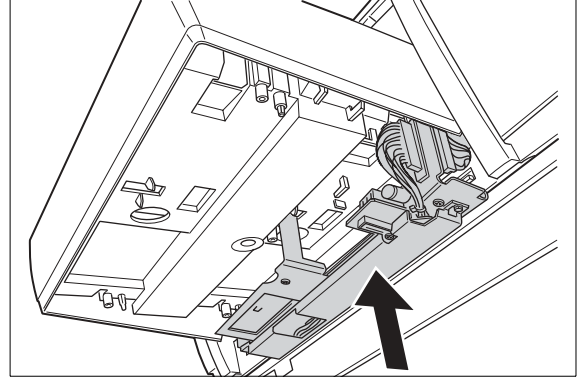

9 Remount 3 screws.

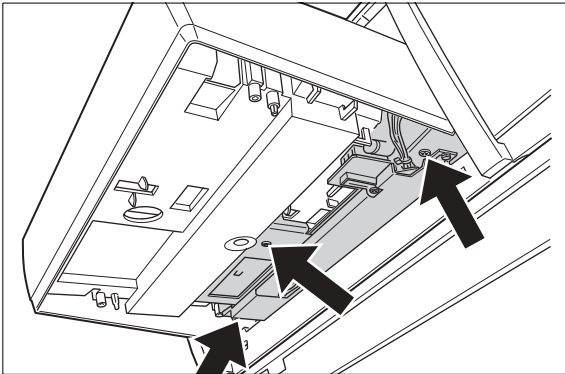

10 Connect the cables

1 Select the power cable.

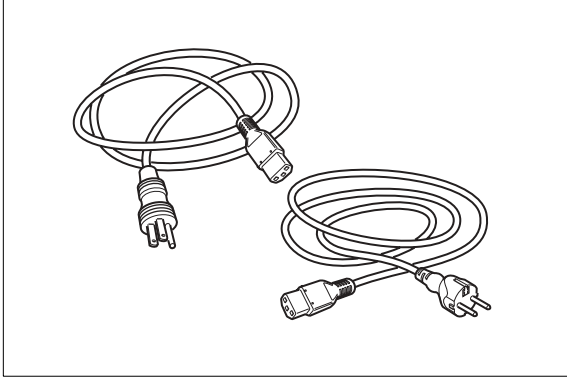

2 Locate the mains connector.

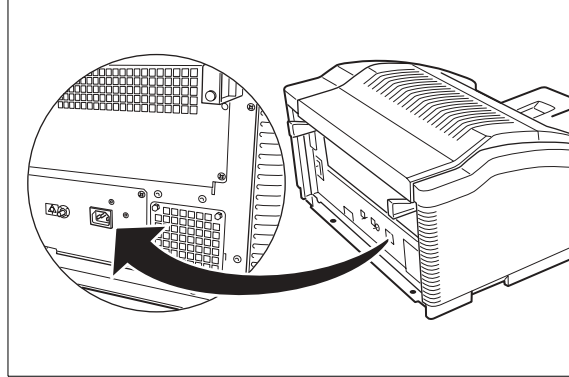

3 Connect the power cable.

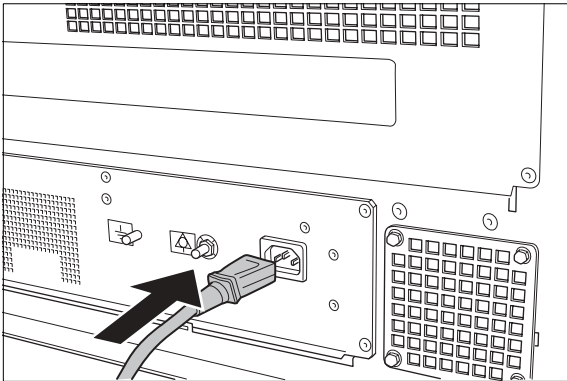

4 Locate the network connector and connect the network cable.

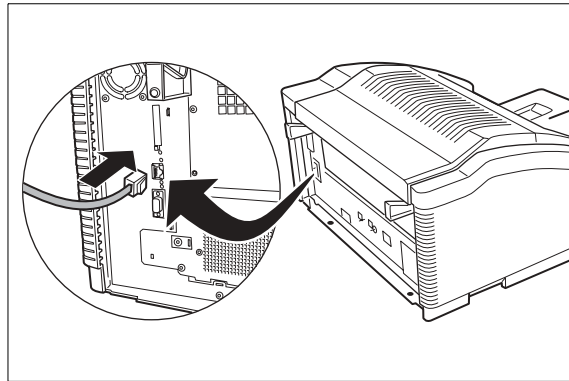

11 Load film in the input tray (1 of 2)

1 Open input tray.

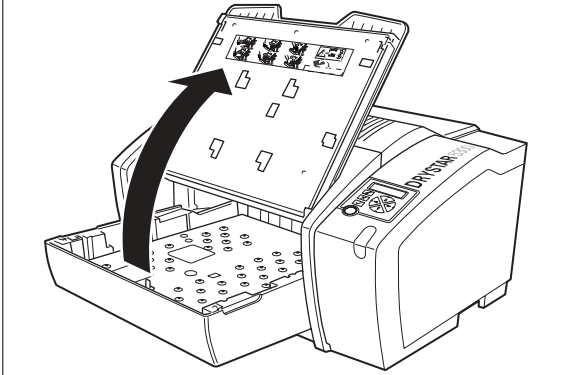

2 Open film box.

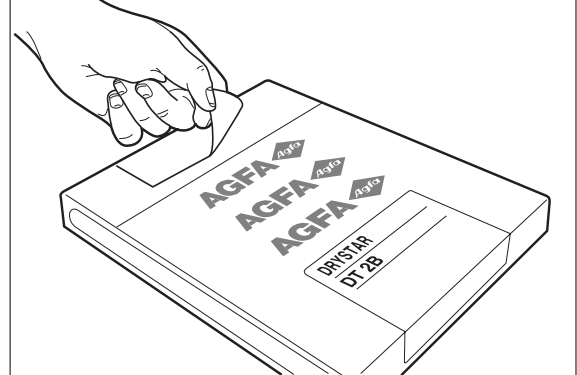

3 Take film pack and slide it into the input tray.

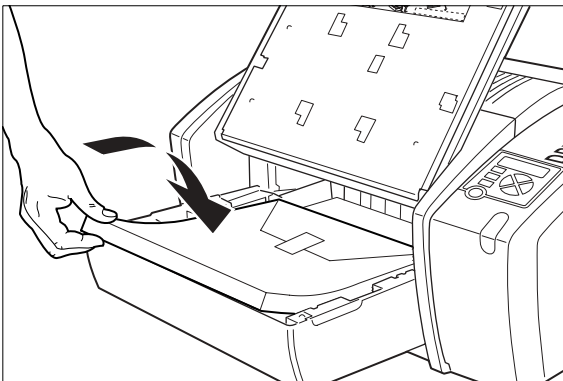

4 Remove sticker.

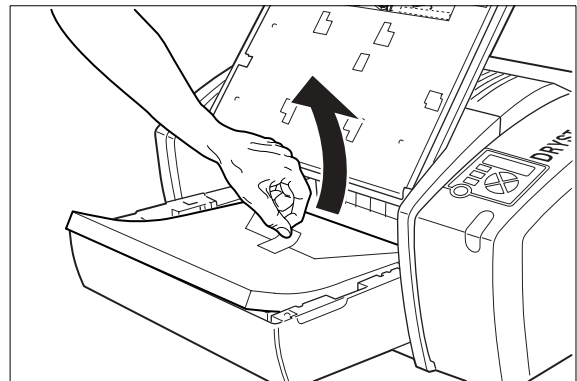

5 Slide film pack further inside.

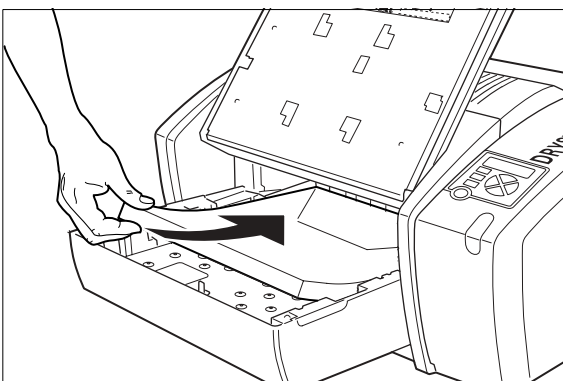

6 Remove plastic film bag.

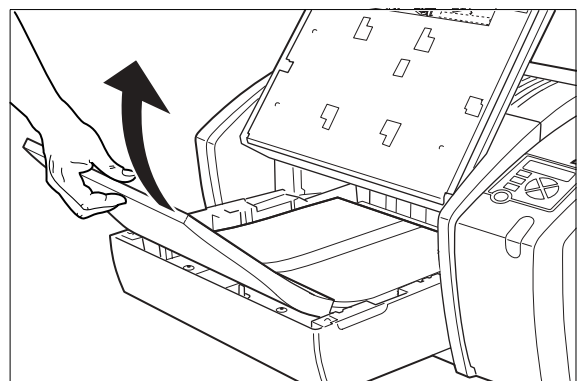

12 Load film in the input tray (2 of 2)

7 Pull plastic tape from around films.

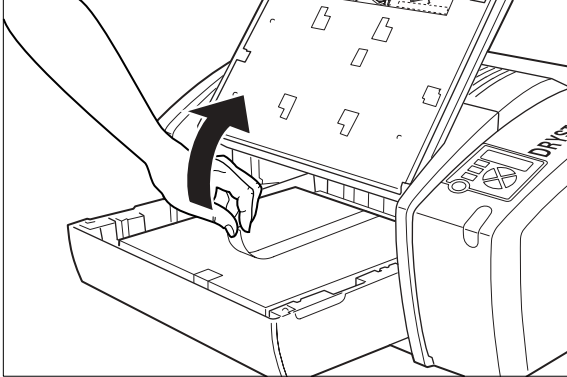

8 Place film type sticker.

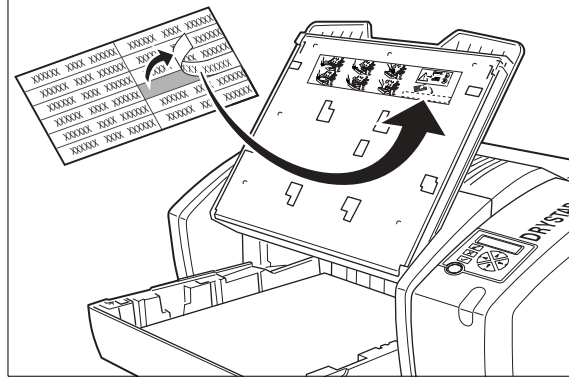

9 Close input tray.

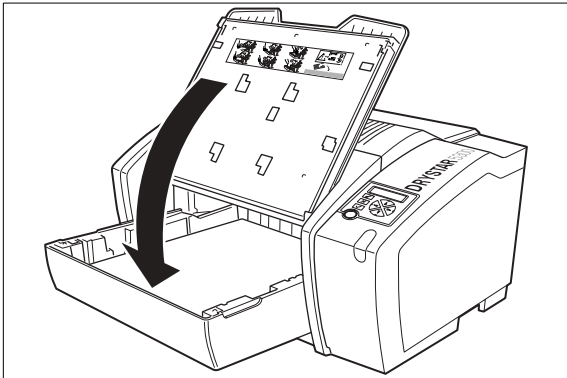

10 Place film type sticker.

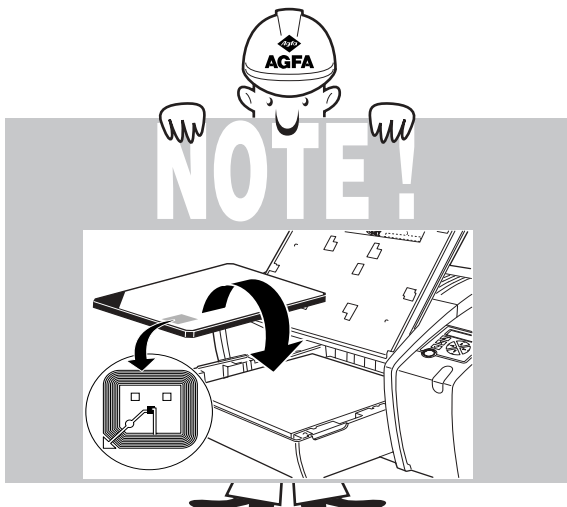
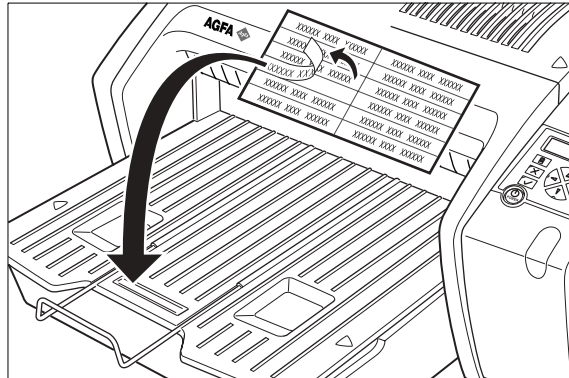

13 Startup Drystar 5300

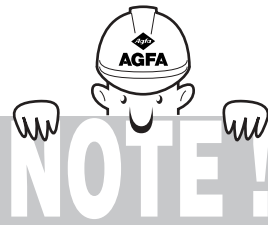

The film delivered with the printer is intended for test purposes only.

1 Remove the display protection foil.

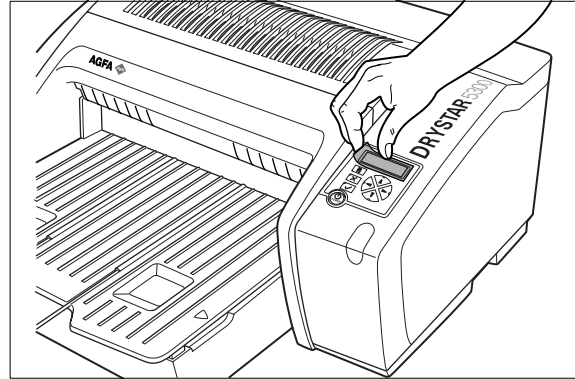

2 Press the POWER button.

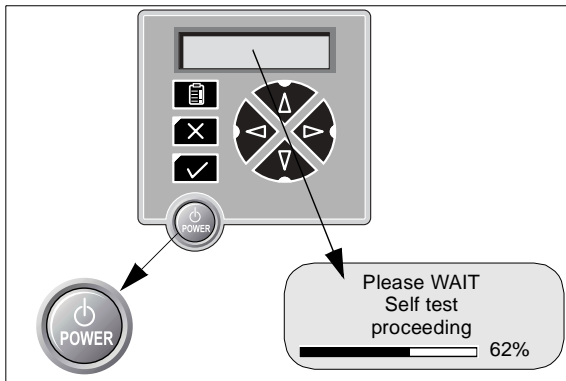

3 Wait until READY.

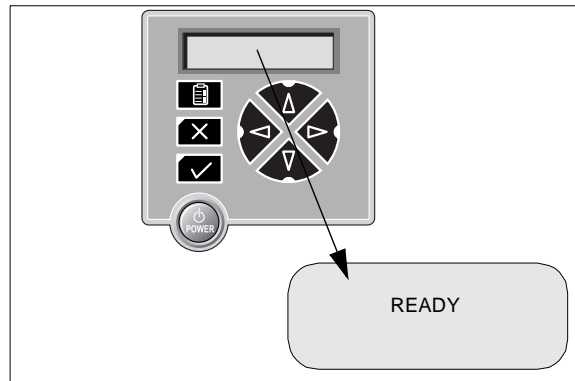

14 Configure network settings



CHECK!

Ask your network manager the following information:

Printer IP address:

Netmask:





Router IP address:

Printer AE_Title:

Service Host IP address:





1 Select and initiate the printer installation wizard.

	1 x	1. Press the Key-operator key.
	8 x	2. Press the Down key eight times.
	1 x	3. Press the Confirm key.
	1 x	4. Press the Down key.
	1 x	5. Press the Confirm key.
		6. Follow the instructions (see Reference manual).

1 Installation from CF card IN

2 Printer installation

2 Select and initiate film calibration.

	1 x	1. Press the Key-operator key.
	5 x	2. Press the Down key five times.
	2 x	3. Press the Confirm key twice.
		4. Follow the instructions (see Reference manual).

SELECT CALIBRATION CA

1 Film calibration

2 Therm. Head clean.

3 Your Drystar 5300 is ready for use!

