



ESP-01/07/12 Series Modules User's Manual

Version 1.1

Ai-Thinker Inc

Copyright (c) 2017

FCC STATEMENT

This device complies with Part 15 of the FCC Rules. Operation is subject to the following two conditions:

(1) This device may not cause harmful interference.

(2) This device must accept any interference received, including interference that may cause undesired operation.

Any changes or modifications not expressly approved by the party responsible for compliance could void the user's authority to operate the equipment.

Please notice that if the FCC identification number is not visible when the module is installed inside another device, then the outside of the device into which the module is installed must also display a label referring to the enclosed module. This exterior label can use wording such as the following: "Contains FCC ID:2AHMR-ESP01M" or "Contains FCC ID:2AHMR-ESP07S" or "Contains FCC ID:2AHMR-ESP12S" or "Contains FCC ID:2AHMR-ESP12F" any similar wording that expresses the same meaning may be used.

This equipment complies with FCC radiation exposure limits set forth for an uncontrolled environment. This equipment should be installed and operated with a minimum distance of 20cm between the radiator & your body. This transmitter must not be co-located or operating in conjunction with any other antenna or transmitter.

CE Mark Warning

CE 0890

The module is limited to OEM installation ONLY.

The OEM integrator is responsible for ensuring that the end-user has no manual instruction to remove or install module.

The module is limited to installation in mobile application;

A separate approval is required for all other operating configurations, including portable configurations with respect to Part 2.1093 and difference antenna configurations.

There is requirement that the grantee provide guidance to the host manufacturer for compliance with Part 15B requirements.

Revision Record

Date	Version	Author	Release Notes
2017.7.1	V1.0	Wang Chong	First Version
2017.9.4	V1.1	Wang Chong	Add ESP-01M, Delete ESP-12E

Table Of Contents

1 Product Overview.....	1
1.1 Product Features.....	1
1.2 Application Plan.....	1
2 Module Interface.....	2
2.1 Package Size.....	2
2.1 Pin Definition.....	5
2.2 Boot Mode.....	6
3 Electrical Characteristics.....	7
3.1 Maximum Ratings.....	7
3.2 Suggested Working Environment.....	7
3.3 Digital Port Features.....	7
3.4 Power Consumption.....	7
3.5 Transmit Power.....	9
3.6 Receive Sensitivity.....	9
4 Hardware Guidance.....	9
4.1 Typical Applications.....	9
4.2 PCB Antenna Display Instructions.....	11
4.3 Module Peripheral Routing Instructions.....	12
4.4 GPIO Level Conversion.....	12
4.5 Power Supply Reference Design.....	13
4.6 ADC Supply Reference Design.....	13
4.7 Automatically Download Reference Design.....	14
4.8 Reflow oven temperature curve.....	14
5 Usage Guide.....	15
5.1 Introduction To The Basic AT Command.....	15
5.1.1 AT.....	15
5.1.2 AT+GMR.....	15
5.1.3 AT+RST.....	15

5.1.4 AT+RESTORE.....	16
5.2 Use Examples.....	16
5.2.1 TCP Communication Test.....	16
5.2.2 UDP Communication Test.....	18
6 FAQ.....	20
6.1 Garbage Instructions When Power Is On.....	20
6.2 How To Shield The Power When The Garbled.....	20
6.3 Can' t Burn Normally.....	20
6.4 SDK Development Environment.....	21
6.5 Startup Information Description.....	21
7 Module Selection.....	21
8 Contact US.....	23

1 Product Overview

ESP8266 series wireless module is a series of cost-effective Wi-Fi SOC module which can be developed independently. The series modules support the standard IEEE802.11 b/g/n protocol, built-in complete TCP/IP protocol stack. Users can use this series of modules to add networking capabilities to existing devices, or to build standalone network controllers.

Ai-Thinker Technology can provide customers with a complete hardware, software reference program, in order to shorten your product development cycle, for your cost savings.

1.1 Product Features

- The smallest 802.11b/g/n Wi-Fi SOC module
- Using low-power 32-bit CPU, can also serve as the application processor
 - Clocked at up to 160MHz
 - Built-in 10 bit high precision ADC
 - Support UART/GPIO/IIC/PWM/ADC/HSPI and other interfaces
 - Integrated Wi-Fi MAC/BB/RF/PA/LNA
 - Supports multiple sleep modes, deep sleep current as low as 20uA
 - Embedded Lwip protocol stack
 - Support STA/AP/STA + AP work mode
 - Supports Smart Config/AirKiss key distribution network
 - Serial port rate up to 4Mbps
 - General AT commands can be used quickly
 - Support SDK secondary development
 - Supports serial local upgrade and remote firmware upgrade (FOTA)

1.2 Application Plan

- | | | |
|----------------------------------|------------------------------|------------------------------------|
| ■ Household appliances | ■ Industrial wireless contro | ■ Wearable electronic products |
| ■ Home automation | ■ Infant Monitor | ■ Wireless location sensing device |
| ■ Smart socket/intelligent light | ■ IP camera | ■ Security ID tag |
| ■ Mesh network | ■ Sensor network | ■ Wireless positioning system |

2 Module Interface

2.1 Package Size

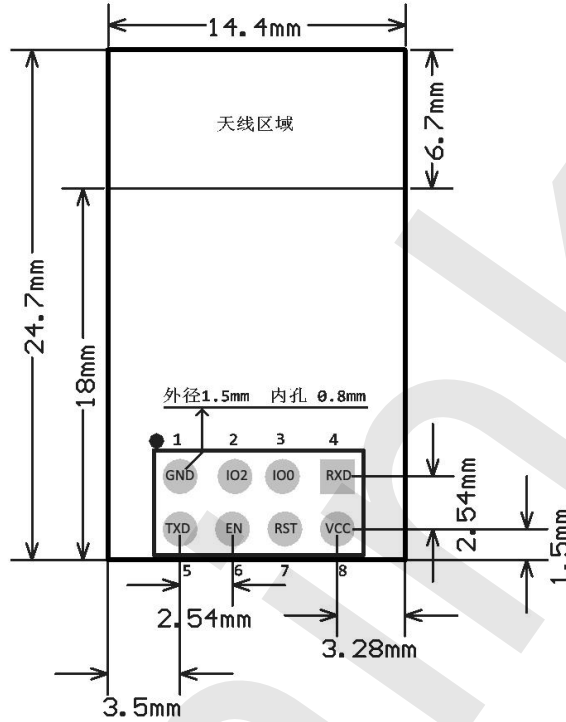


Figure 2.1 ESP-01/ESP-01S pin dimensions

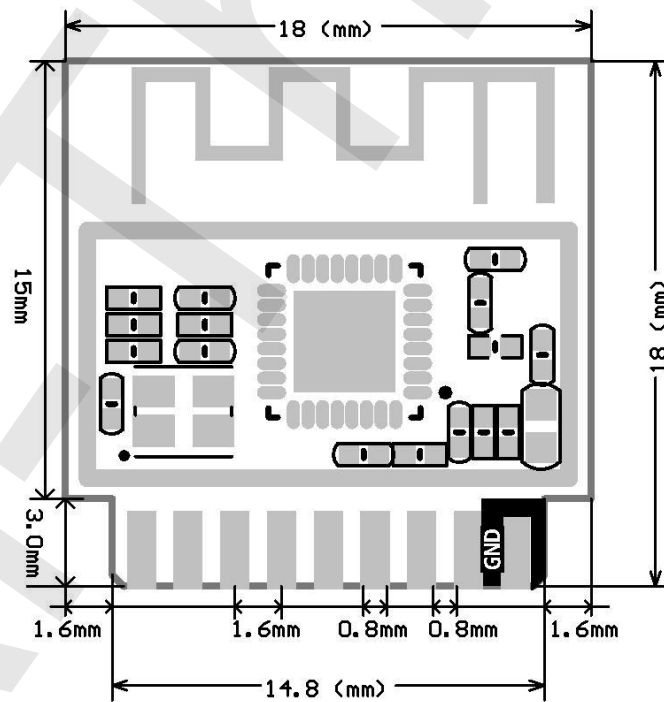


图 2.2 ESP-01M 管脚尺寸图

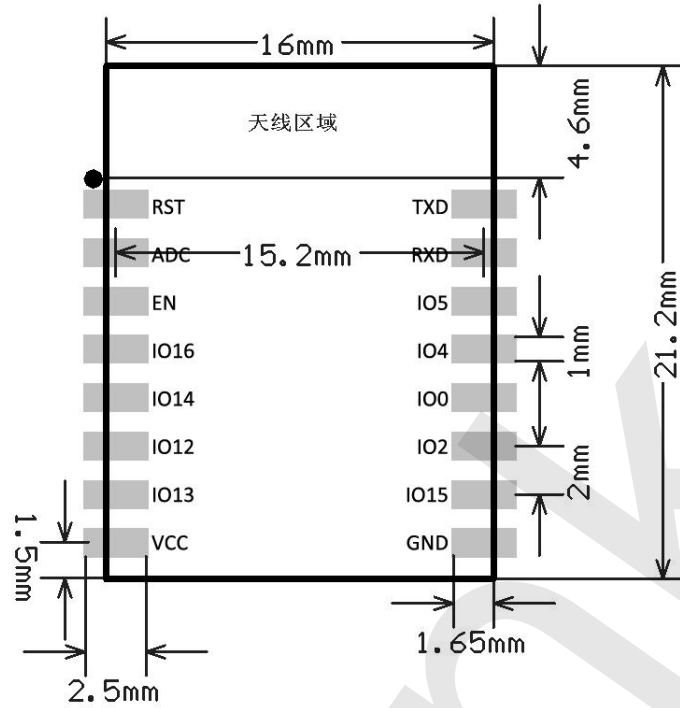


Figure 2.3 ESP-07 pin dimensions

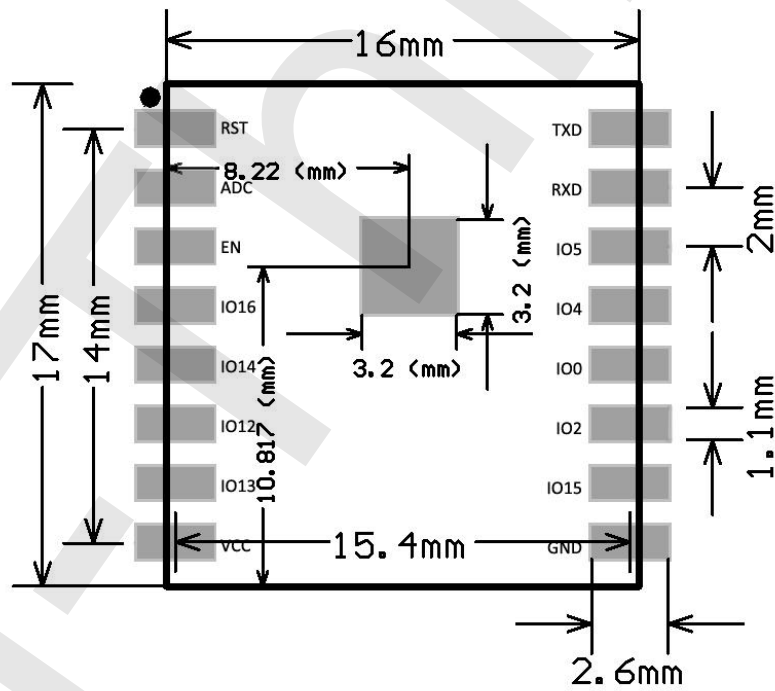


Figure 2.4 ESP-07S pin dimensions

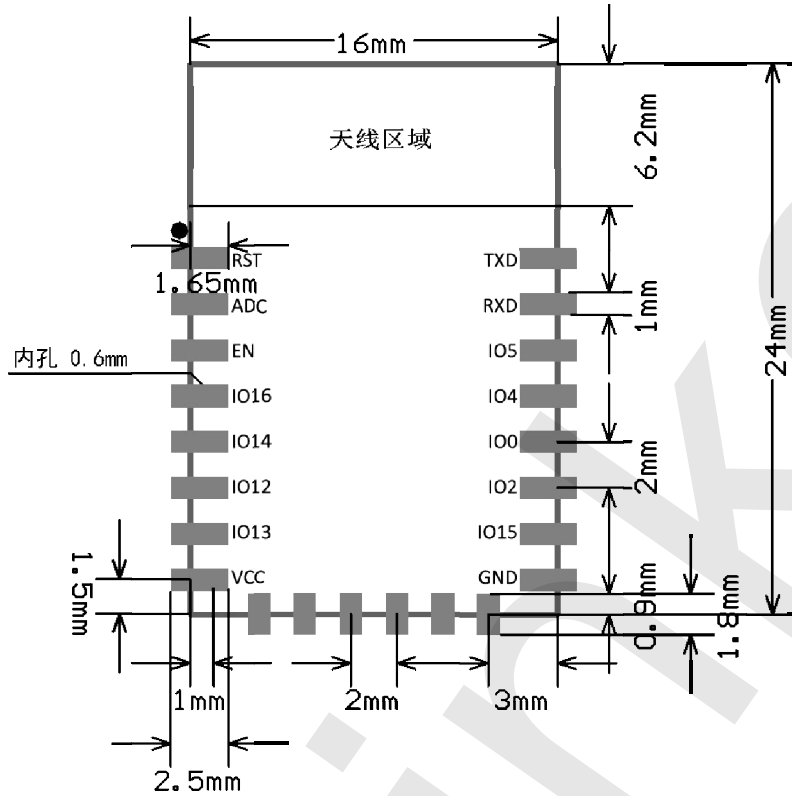


Figure 2.5 ESP-12F pin dimensions

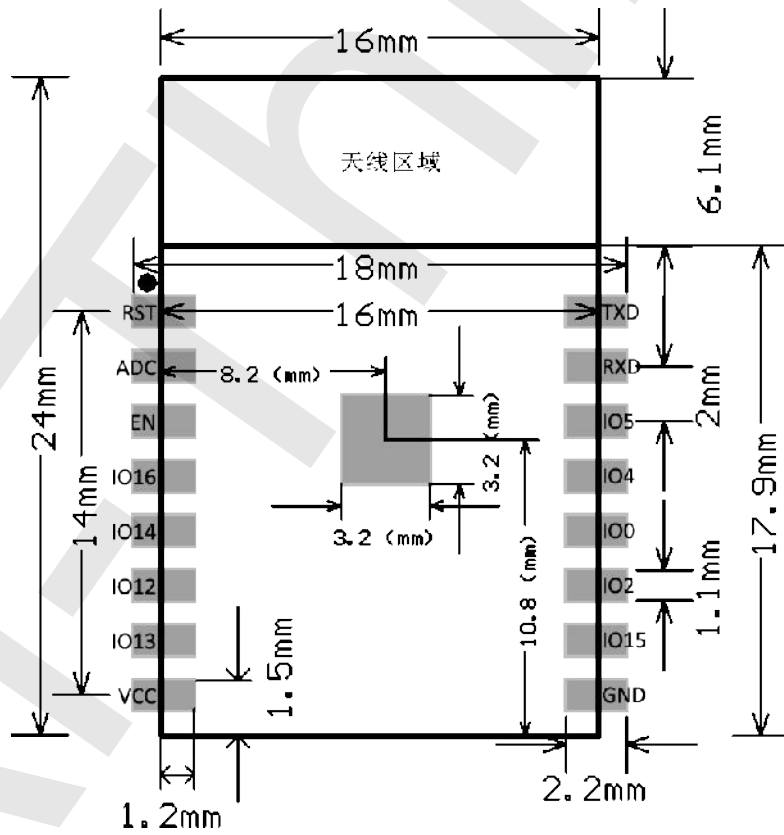


Figure 2.6 ESP-12S pin dimensions

Table 2.1 ESP series module size table

Model	Length (mm)	Width (mm)	Height (mm)	PAD size (mm)	Pin Spacing (mm)	Shield ed Shell (mm)	Thickness (mm)
ESP-01 ESP-01S	24.7	14.4	11.0	1.5 x 1.5	2.54	-	1.0± 0.1
ESP-01M	18	18	2.8± 0.2	-	0.8	2.0	0.8± 0.1
ESP-07	21.2	16.0	3± 0.2	-	1.5	2.0	0.8± 0.1
ESP-07S	17.0	16.0	3± 0.3	1 x 1.2	1.5	2.0	0.8± 0.1
ESP-12F	24.0	16.0	3± 0.2		1.5	2.0	0.8± 0.1
ESP-12S	24.0	16.0	3± 0.2	1 x 1.2	1.5	2.0	0.8± 0.1

2.1 Pin Definition

Table 2.2 ESP Series Module Pin Function Definitions

Pin Number				Pin Name	Remarks
01 01S	01M	07 07S 12S	12F		
7	18	1	1	RST	Reset Pin, Active Low
-	16	2	2	ADC	AD conversion, Input voltage range 0~1V, the value range is 0~1024.
6	9	3	3	EN	Chip Enabled Pin, Active High
-	17	4	4	IO16	Connect with RST pin to wake up Deep Sleep
-	15	5	5	IO14	HSPI_CLK, IR_T, I2C_SCL,
-	14	6	6	IO12	HSPI_MISO
-	5	7	7	IO13	HSPI_MOSI; UART0_CTS
8	2	8	8	VCC	Module power supply pin, the
-	-	-	9	CS0	Flash chip select signal
-	-	-	10	MISO	Slave Output Master Input
-	11	-	11	IO9	GPIO9
-	12	-	12	IO10	GPIO10
-	-	-	13	MOSI	Master Output Slave Input

-	-	-	14	SCLK	Clock
1	1	9	15	GND	GND
-	6	10	16	IO15	HSPI_CS, U0_RTS, I2SO_BCK
2	7	11	17	IO2	U1_TXD, I2C_SDA, I2SO_WS
3	8	12	18	IO0	GPIO0, HSPI_MISO, I2SI_DATA
-	10	13	19	IO4	HSPI_MOSI, U0_CTS, I2SI_BCK
-	13	14	20	IO5	IR_R
4	4	15	21	RXD	GPIO3, I2SO_DATA
5	3	16	22	TXD	GPIO1

Note: Only GPIO4 and GPIO5 are low at boot time, the other GPIO are high.

2.2 Boot Mode

Table 2.3 Description of the ESP series module boot mode

Mode	CH_PD (EN)	RST	GPIO15	GPIO0	GPIO2	TXD0
Download mode	high	high	low	low	high	high
Running mode	high	high	low	high	high	high
Chip Test mode	high	high	-	-	-	low

3 Electrical Characteristics

3.1 Maximum Ratings

Table 3.1 Maximum Ratings

Rated value	condition	Value	Unit
Storage Temperature	-	-40 ~ 90	°C
Maximum Welding Temperature	-	250	°C
Supply Voltage	IPC/JEDEC J-STD-020	+3.0 ~ +3.6	V

3.2 Suggested Working Environment

Table 3.2 Recommended working environment

Work Environment	Name	Min	Typ	Max	Unit
Operating Temperature		-20	20	85	°C
Supply Voltage	VDD	3.0	3.3	3.6	V

3.3 Digital Port Features

Table 3.3 Digital Port Features

Port	Name	Min	Typ	Max	Unit
Input logic level low	VIL	-0.3	-	0.25 * VDD	V
Input logic level high	VIH	0.75 * VDD	-	VDD + 0.3	V
Output logic level low	VOL	N	-	0.1 * VDD	V
Output logic level high	VOH	0.8 * VDD	-	N	V

Note: Unless otherwise specified, the test conditions are: VDD = 3.3 V and temperature 20 °C.

3.4 Power Consumption

All measurements are made at the antenna interface without SAW filters.

All transmit data is based on a 90% duty cycle measured in the continuous firing mode.

Table 3.4 Power consumption

Mode	Min	Typ	Max	Unit
Transmit 802.11b, CCK 11Mbps, POUT = +17dBm		170		mA
Transmit 802.11g, OFDM 54Mbps, POUT = +15dBm		140		mA
Transmit 802.11n, MCS7, POUT = +13dBm		120		mA
Receive 802.11b, packet length 1024 bytes, -80dBm		50		mA
Receive 802.11g, packet length 1024 bytes, -70dBm		56		mA
Receive 802.11n, packet length 1024 bytes, -65dBm		56		mA
Modem-Sleep ^①		20		mA
Light-Sleep ^②		2		mA
Deep-Sleep ^③		20		uA
Power Off		1		uA

Note: Modem-Sleep is used to require the CPU to remain in operation, such as PWM or I2S. When there is no data transmission while maintaining a WiFi connection, power off the WiFi Modem circuit according to the 802.11 standard (eg U-APSD). For example, in DTIM3, every sleep 300mS, wake up 3mS receive AP Beacon package, etc., the overall average current of about 20mA.

Note ②: Light-Sleep for CPU can be suspended applications, such as WiFi switch. If there is no data transmission while maintaining a WiFi connection, the WiFi Modem circuit can be switched off and the CPU is powered down according to the 802.11 standard (eg U-APSD). For example, at DTIM3, every sleep 300 ms, wake up 3 ms to receive AP's Beacon packets, etc., the overall average current is about 2 mA.

Note: Deep-Sleep is used for applications that do not have to keep the WiFi connection for a long time, such as a sensor that measures the temperature once every 100 seconds. Every 300 s wake up after 0.3s - 1s connected to the AP to send data, the overall average current can be much smaller than 2mA.

3.5 Transmit Power

Table 3.5 RF parameters

Describe	Min	Typ	Max	Unit
802.11b@11Mbps	14	16	18	dBm
802.11g@54Mbps	12	14	16	dBm
802.11n@HT20, MCS7	11	13	15	dBm

3.6 Receive Sensitivity

Table 3.6 Receiving Sensitivity

Parameter	Min	Typ	Max	Unit
DSSS, 1 Mbps		-95		dBm
CCK, 11 Mbps		-80		dBm
6 Mbps (1/2 BPSK)		-88		dBm
54 Mbps (3/4 64-QAM)		-70		dBm
HT20, MCS7 (65 Mbps, 72.2 Mbps)		-67		dBm

4 Hardware Guidance

4.1 Typical Applications

Note: You can't use USB to TTL 3.3V or 5V power supply, it is recommended to use two dry batteries or after conversion through the LDO 3.3V, it is strongly recommended to buy a new development board.

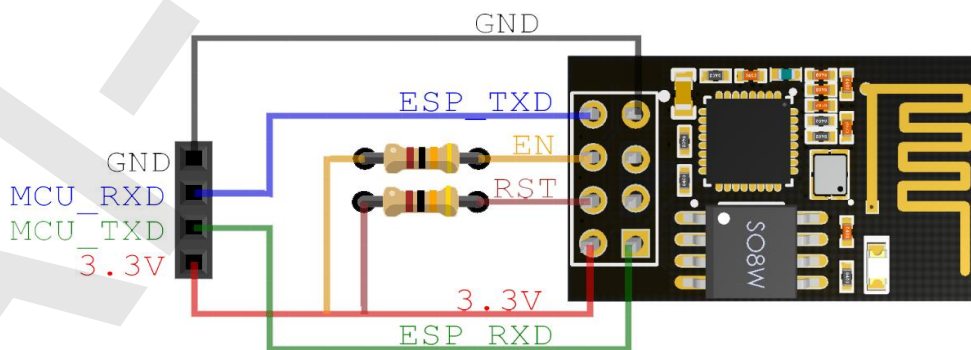


Figure 4.1 Typical application of ESP-01

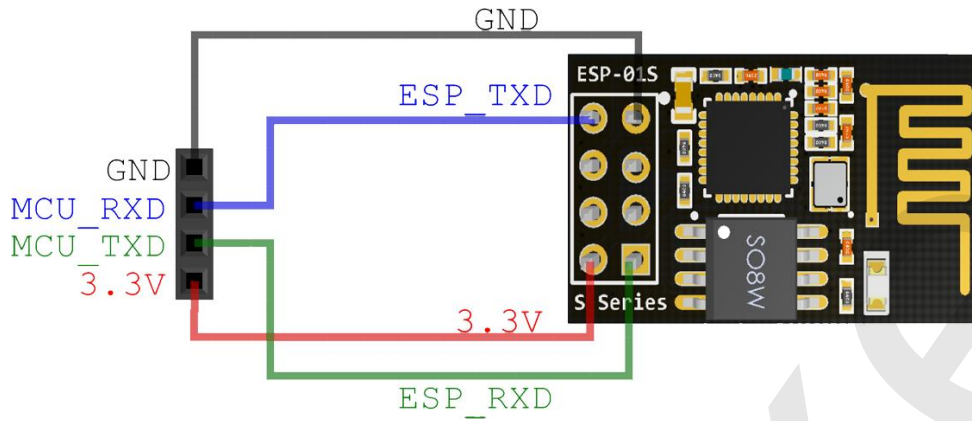


Figure 4.2 Typical application of ESP-01S

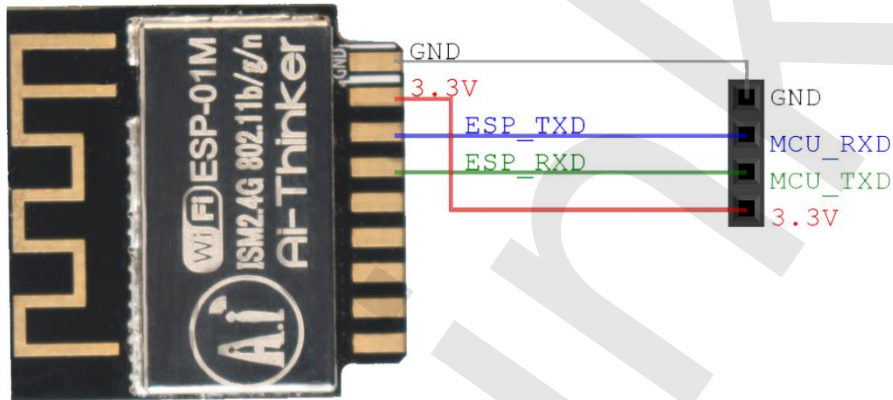


Figure 4.3 Typical application of ESP-01M

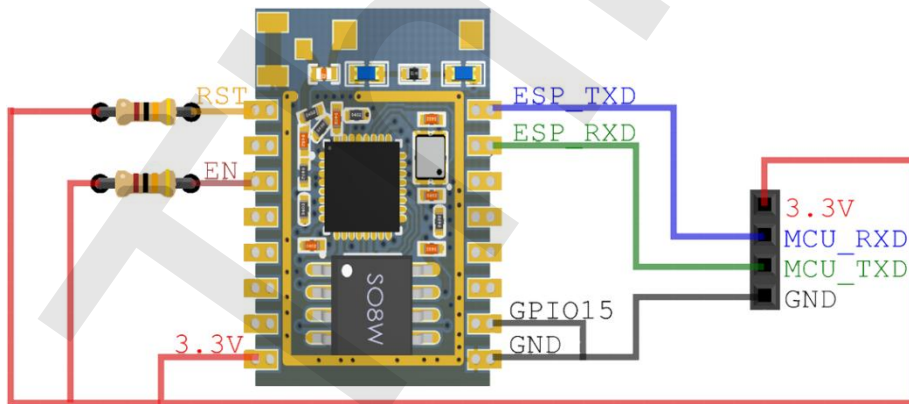


Figure 4.4 Typical application of ESP-07

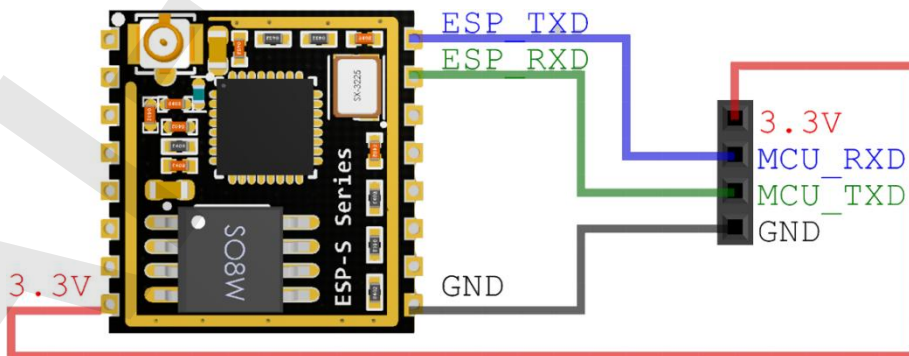


Figure 4.5 Typical application of ESP-07S

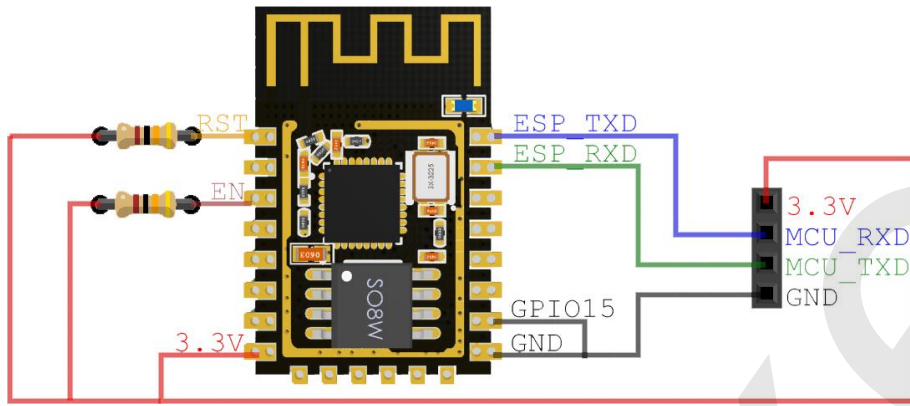


Figure 4.6 Typical application of ESP-12E/ESP-12F

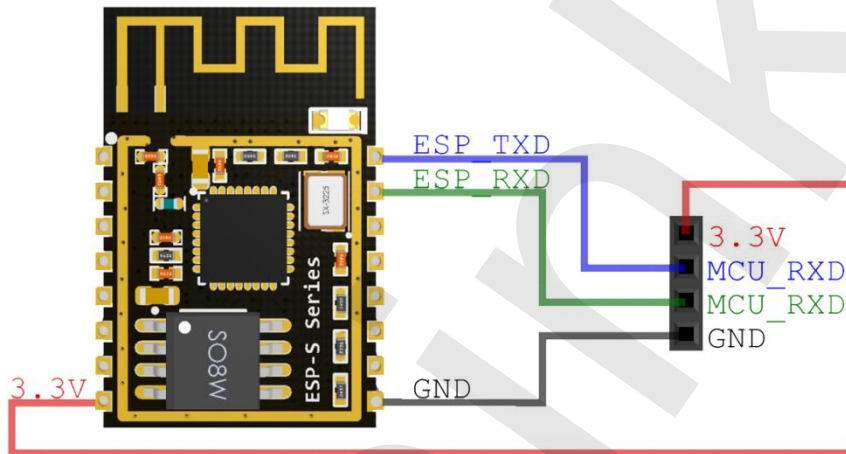


Figure 4.7 Typical application of ESP-12S

4.2 PCB Antenna Display Instructions

The ESP8266 series module can be soldered to the PCB board. In order to get the best RF performance of the end product, please pay attention to the rational design of the module and the placement of the antenna on the bottom plate according to this guide.

Option 1 (recommended):

Place the module along the edge of the PCB board, and the antenna is placed outside the frame or along the board and the bottom is hollowed out;

Option 2:

The module placed along the PCB board side, the antenna placed along the board and the bottom of the hollow;

Option 3:

Place the module along the board side of the board, the antenna placed along the

board and the bottom are not copper.

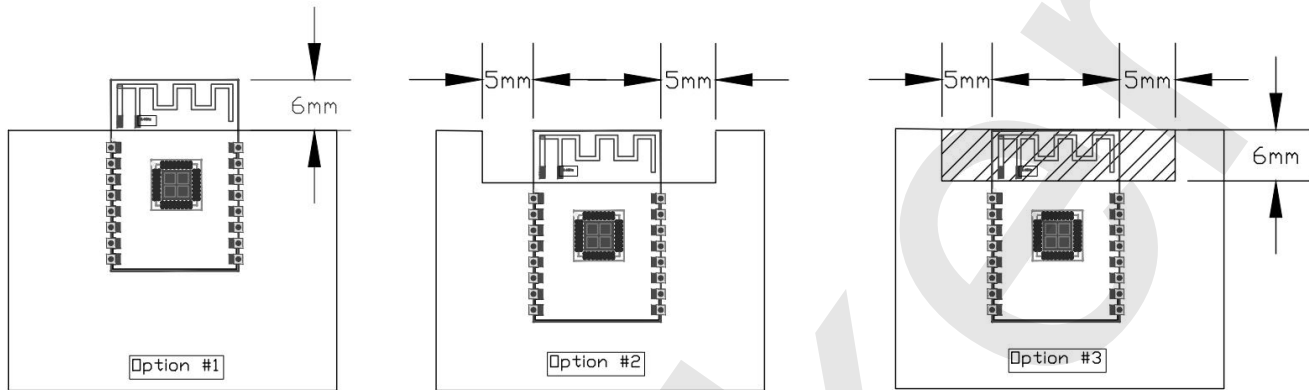


Figure 4.7 ESP-12S antenna placement instructions

4.3 Module Peripheral Routing Instructions

The ESP8266 series modules integrates high-speed GPIO and peripheral interfaces, which can cause severe switching noise. If some applications require high power and EMI characteristics, it is recommended to connect 10 to 100 ohms in series on digital I/O lines. This can suppress overshoot when switching power supplies and make the signal smooth. Series resistance can also prevent electrostatic discharge (ESD) to some extent.

4.4 GPIO Level Conversion

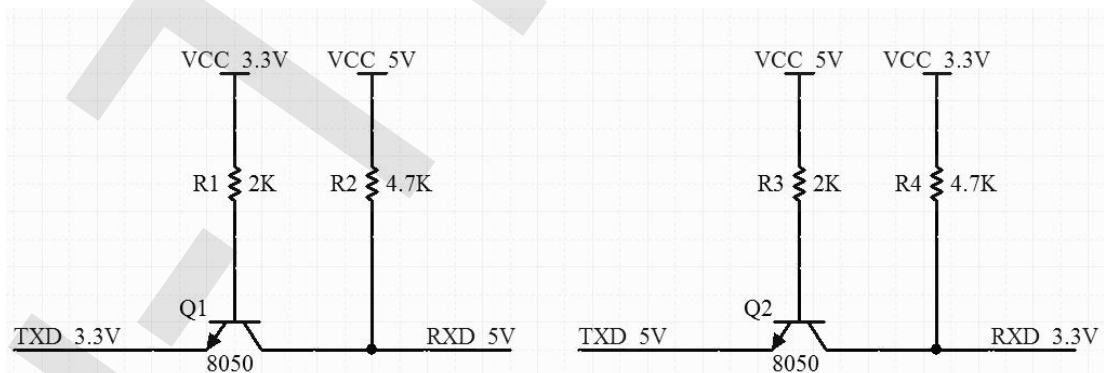


Figure 4.8 Transistor level conversion

4.5 Power Supply Reference Design

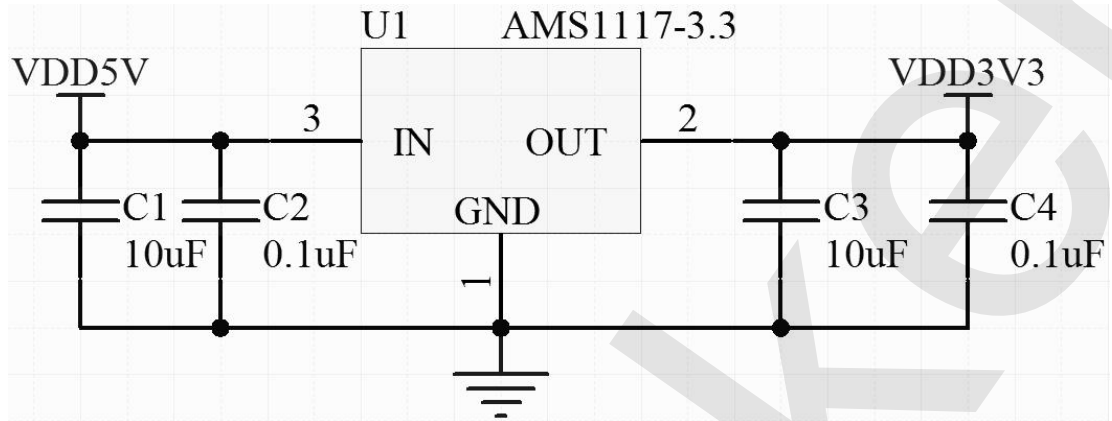


Figure 4.9 Power supply reference

4.6 ADC Supply Reference Design

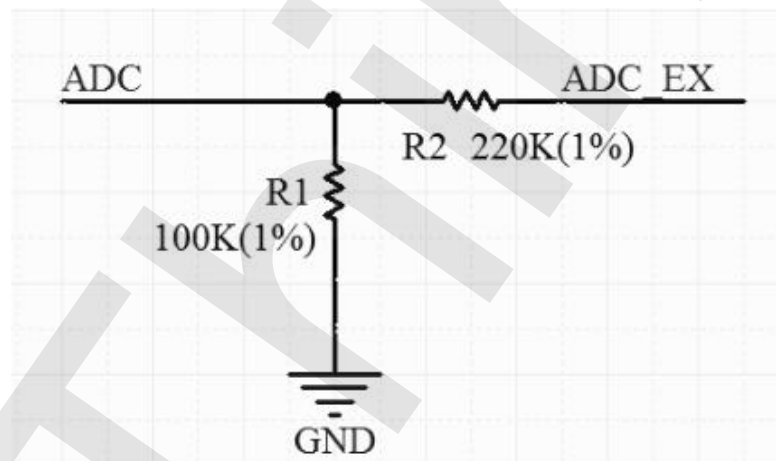


Figure 4.10 ADC supply reference

4.7 Automatically Download Reference Design

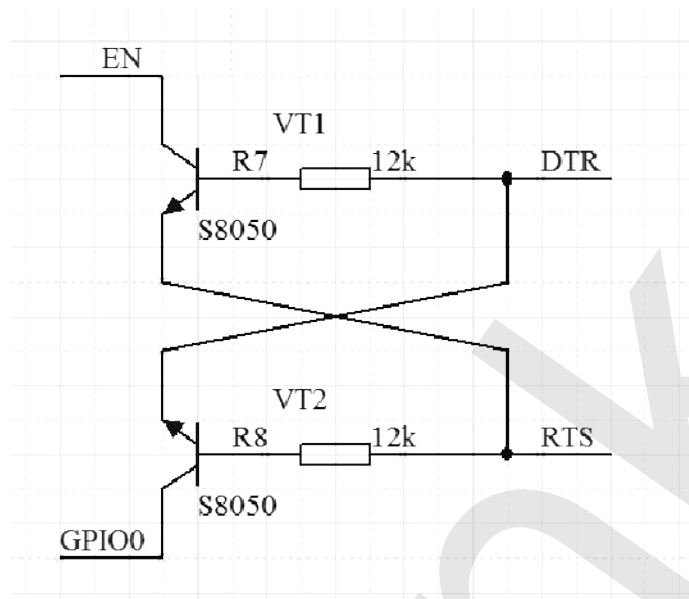
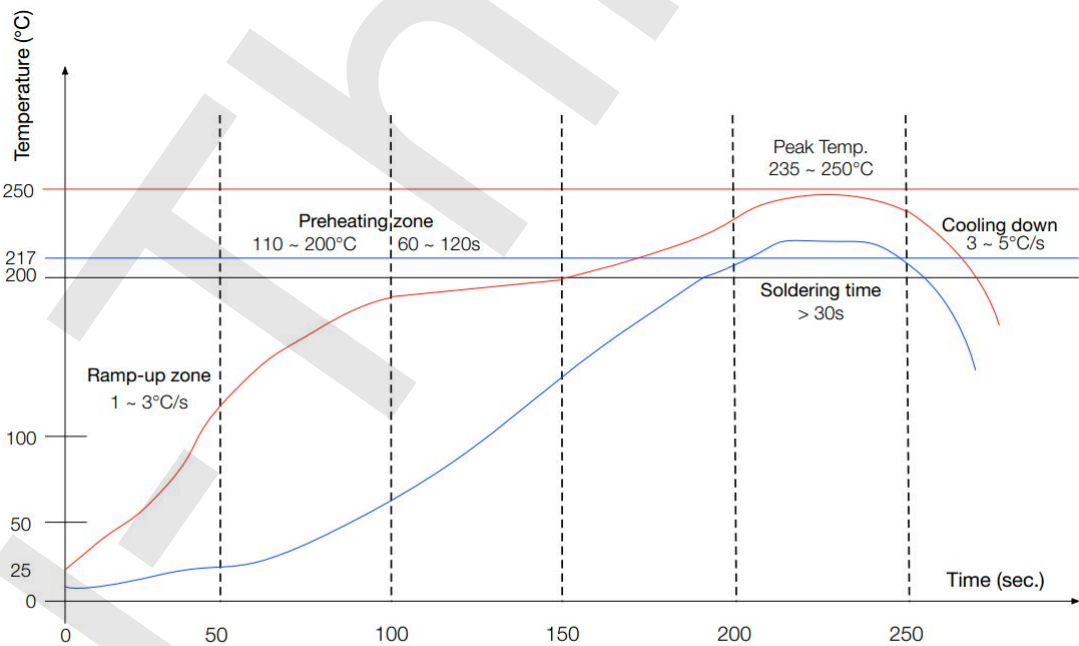


Figure 4.11 Automatically Download Reference Design

4.8 Reflow oven temperature curve



Ramp-up zone (升温区): Temp. <150°C, Time 60 ~ 90s, Ramp-up rate 1 ~ 3°C/s.
 Preheating zone (预热恒温区): Temp. 150 ~ 200°C, Time 60 ~ 120s, Ramp-up rate 0.3 ~ 0.8°C/s.
 Reflow soldering zone (回流焊接区): Peak Temp. 235 ~ 250°C (<245°C recommended), Time 30 ~ 70s.
 Cooling down zone (冷却区): Temp. 217 ~ 170°C, Ramp-down rate 3 ~ 5°C/s.
 Sn&Ag&Cu Lead-free solder (SAC305)/焊料为锡银铜合金无铅焊料

Figure 4.12 Reflow furnace temperature curve

5 Usage Guide

ESP8266 series module factory default built-in AT firmware, and the default baud rate of 115200, can refer to 4.1 typical application diagram to build the minimum system circuit, then the AT command operation.

Serial and network debugging tools download: <http://wiki.ai-thinker.com/tools>

5.1 Introduction To The Basic AT Command

This chapter only describes the common AT commands, please refer to <http://wiki.ai-thinker.com/esp8266/docs#at>.

5.1.1 AT

parameters	No
Description	Test AT is OK
Example	AT OK

5.1.2 AT+GMR

parameters	No
Description	Returns the firmware version information
Example	AT+GMR AT version:1.2.0.0(Jul 1 2016 20:04:45) SDK version:1.5.4.1(39cb9a32) Ai-Thinker Technology Co. Ltd. Dec 2 2016 14:21:16 OK

5.1.3 AT+RST

parameters	No
Description	soft restart module
Example	AT+RST OK

5.1.4 AT+RESTORE

parameters	No
Description	Reset the module to factory settings
Example	AT+RESTORE OK

5.2 Use Examples

This section explains how to configure two modules through the serial port on the PC side to communicate with each other over TCP/UDP. For more examples, please refer to: http://wiki.ai-thinker.com/esp8266/examples/at_demo. Test, through the PC side instead of one end of the module to establish the appropriate connection.

5.2.1 TCP Communication Test

TCP Server is in AP mode and TCP Client is Station mode.

TCP Server Configuration:

Ai-Thinker Technology Co. Ltd.

ready

AT+CWMODE=2 //configured for AP mode

OK

AT+CWSAP_DEF="TCP_Server","12345678",5,4 //Configure AP information

OK

AT+CIFSR //Query the local IP address

+CIFSR:APIP,"192.168.4.1"

+CIFSR:APMAC,"a2:20:a6:19:c7:0a"

OK

AT+CIPMUX=1 //open multiple links

OK
AT+CIPSERVER=1 //open the server

OK
0,CONNECT //There is a client connected to the server

+IPD,0,10: Ai-Thinker //received 10 data (Ai-Thinker)
AT+CIPSERVER=0 //Close the server

OK
0,CLOSED //TCP connection is off

TCP Client Configuration:

Ai-Thinker Technology Co. Ltd.

ready
AT+CWMODE=1 //configured for station mode

OK
AT+CWJAP_DEF="TCP_Server","12345678" //Connect to AP

WIFI CONNECTED
WIFI GOT IP

OK
AT+CIFSR //Query the local IP address

+CIFSR:STAIP,"192.168.4.2"
+CIFSR:STAMAC,"5c:cf:7f:91:8b:3b"

OK
AT+CIPMUX=0 //open single link

OK
AT+CIPSTART="TCP","192.168.4.1",333 //Connect to TCP server

CONNECT

OK
AT+CIPSEND=10 //send 10 bytes of data to the server side

```

OK
> //After the emergence of the symbol serial port to send
Ai-Thinker (without carriage return line)
Recv 10 bytes //The serial port receives the data

SEND OK //sent successfully
CLOSED //TCP connection is closed
  
```

5.2.2 UDP Communication Test

One is in AP mode , the local port is 8001, and the other is Station mode. the local port is 8002.

AP Configuration:

Ai-Thinker Technology Co. Ltd.

ready

```
AT+CWMODE=2 //configured for AP mode
```

OK

```
AT+CWSAP_DEF="TCP_Server","12345678",5,4 //AP information
```

OK

```
AT+CIFSR //Query the local IP address
```

```
+CIFSR:APIP,"192.168.4.1"
```

```
+CIFSR:APMAC,"a2:20:a6:19:c7:0a"
```

OK

```
AT+CIPSTART="UDP","192.168.4.2",8002,8001,0 //Open UDP
connection
```

```
CONNECT
```

OK

```
+IPD,10: Ai-Thinker //received 10 data (Ai-Thinker)
```

```
AT+CIPSEND=10 //send 10 bytes of data to the server
```

OK

```
> //After the emergence of the symbol serial port to send
Ai-Thinker (without carriage return line)
Recv 10 bytes //The serial port receives the data

SEND OK
AT+CIPCLOSE //close the UDP connection

CLOSED

OK
Station Configuration:
Ai-Thinker Technology Co. Ltd.

ready
AT+CWMODE=2 //configured for station mode

OK
AT+CWSAP_DEF="TCP_Server","12345678",5,4 //Connect to AP

OK
AT+CIFSR //Query the local IP address

+CIFSR:STAIP,"192.168.4.2"
+CIFSR:STAMAC,"5c:cf:7f:91:8b:3b"

OK
AT+CIPSTART="UDP","192.168.4.1",8001,8002,0 //Open UDP connection

CONNECT

OK
AT+CIPSEND=10 //send 10 bytes of data to the server

OK
> //After the emergence of the symbol serial port to send
Ai-Thinker (without carriage return line)

Recv 10 bytes //The serial port receives the data

SEND OK
```


+IPD,10: Ai-Thinker //received 10 data (Ai-Thinker)

AT+CIPCLOSE //close the UDP connection

CLOSED

OK

6 FAQ

6.1 Garbage Instructions When Power Is On

ESP8266 chip itself supports 26MHz and 40MHz crystal, if the use of 40MHz crystal, the default baud rate of 115200, if the use of 26MHz crystal, the UART0 power after the baud rate = $26 * 115200 / 40 = 74880$, the letter can be ESP8266 Series modules are used 26MHz, because the general serial port tool does not support the baud rate, so there will be printed on the garbled.

You can use the security serial interface assistant to configure the baud rate 74880 to view the startup information.

Note: part of the USB to TTL does not support 74880 baud rate, the computer comes with RS232 to TTL does not support 74880 baud rate, recommend the use of FT232, CP2102, CH340 and other chips.

6.2 How To Shield The Power When The Garbled

U0TXD default power will be system printing, through the UART's internal pin switching function, user_init () call system_uart_swap () function, the new U0TXD change to GPIO15, U0RXD change to GPIO13, the hardware connection on the two cited Feet can be serial communication.

Note: After the exchange, the download pin on the hardware is still the original U0TXD and U0RXD.

6.3 Can't Burn Normally

Refer to http://wiki.ai-thinker.com/esp_download to download, pay attention to download before the module to ensure that the download mode.

6.4 SDK Development Environment

Refer to http://wiki.ai-thinker.com/ai_ide_install to build the SDK development environment.

6.5 Startup Information Description

Start, if the power and serial port connection is normal, then the baud rate 74880 to see the first sentence is as follows:

```
ets Jan 8 2013,rst cause:1, boot mode:(3,6)
```

The start and start modes of the module can be analyzed based on the print information:

rst cause :

- 1: Power restart
- 2: External reset
- 4: Hardware watchdog reset

boot mode:

The second in parentheses has no practical meaning, the first can refer to the following table to start the information analysis:

Table 6.1 Startup Mode Description

Value	Mode	GPIO0	GPIO2	GPIO15
0	-	0	0	0
1	Download Mode	0	1	0
2	-	1	0	0
3	Run mode	1	1	0
4	-	0	0	1
5	-	0	1	1
6	-	1	0	1
7	-	1	1	1

7 Module Selection

model	ESP-01	ESP-01S	ESP-01M	ESP-07	ESP-07S	ESP-12F	ESP-12S
Package	DIP-8	DIP-8	SMD-18	SMD-16	SMD-16	SMD-22	SMD-16

Size(mm)	24.7*14.4	24.7*14.4	18*18	21.2*16.0	17.0*16.0	24.0*16.0	24.0*16.0
layer	2	2	4	2	4	4	4
Flash size	8Mbit	8Mbit	8Mbit	8Mbit	32Mbit	32Mbit	32Mbit
Certification	-	-	-	-	FCC/CE	FCC/CE	FCC/CE
Antenna	PCB	PCB	PCB	Ceramic IPEX	IPEX	PCB	PCB
Indicator light	TXD0 POWER	GPIO2	GPIO2 POWER	-	GPIO2	GPIO2	GPIO2
Available IO	2	2	11	9	9	9	9

For more selection information please see <http://wiki.ai-thinker.com/esp8266> or contact us.

8 Contact US

Official website: <https://www.ai-thinker.com>

Develop Wiki: <http://wiki.ai-thinker.com>

Official forum: <http://bbs.ai-thinker.com>

Sample purchase: <https://anxinke.taobao.com>

Business cooperation: sales@aithinker.com

Technical support: support@aithinker.com

Telephone: 400-855-5368

Company Address: 6/F, Block C2, Huafeng Industrial Park, Hangcheng Road,
Bao'an Road, Baoan District, Shenzhen ,China



WeChat



AiSmart APP