

Pump Gun Conversion Kit

Please Note: To install this kit you must have a mainbody with an enlarged sear slot; all 68AUTOMAGs and MINIMAGs manufactured after June 1994 will have this type of mainbody. If you are unsure of the date, check with the factory. You will also need a custom rail with a pump slot. All current custom rails from Airgun Designs have the required slot.

Tools required:

1/8" Allen (hex) wrench

3/16" Allen (hex) wrench (For disassembly)

Please read all instructions prior to assembly.

Initial Installation:

1. Degas marker and remove gas source.
2. Remove Barrel, Valve Assembly, mainbody, and Vertical bottle adapter (if so equipped) from the Rail.
3. Remove Power Tube Tip to access the Power Tube Spring. Remove Power Tube Spring and replace with Power Tube Spacer included in kit. Reinstall Power Tube Tip. **See Figure A.**
4. Remove blue Bumper from the Power Tube and replace with black Bumper included in kit.
5. Place Wave Spring around black Bumper.
6. Remove Frame Assembly from Rail
7. Remove all parts necessary from your old rail and install onto new rail (i.e. Sear Assy, Bottle Mounts, etc.)
See Figure B.
8. Remove Pump Rod from storage position in Pump Handle Assembly.
9. Insert L-shaped end of Pump Rod into oval hole in Pump Handle Assembly and snap Pump Rod firmly into place as shown in Figure B.
10. Slide Pump Handle Assembly onto front of Rail, ensuring that Pump Rod rests in Pump Slot and that Pump Post Mount rests underneath Rail.

For Markers without Vertical Bottle Adapter:

- 11a. Place 1/4-20 hex nut in bottom of Pump Post Mount.
- 12a. Insert 1/4-20 x 1/2" screw through Rail into nut and tighten.
- 13a. Reassemble marker.

For Markers with Vertical Bottle Adapter:

- 11b. Place Vertical Bottle Adapter under Pump Post Mount.
- 12b. Insert long 1/4-20 x 3/4" screw through Rail and Pump Post Mount into Vertical Bottle assembly and tighten.
- 13b. Reassemble marker.

NOTE: Pump Handle Assembly may be removed from Marker without mainbody removal by using a 3/16" Allen wrench to unscrew Pump Post from its mount.

Converting Pump Marker to Semi-Automatic Marker:

NOTE: The Pump Post Mount can remain on the marker.

1. Degas marker and remove gas source.
2. Remove Valve Assembly.
3. Remove Wave Spring from black Bumper.
4. Remove black Bumper from the Power Tube and replace with blue Bumper.
(NOTE: Power Tube Spacer may need to be removed for proper operation.)

Converting Semi-Automatic Marker to Pump Marker:

1. Degas marker and remove gas source.
2. Remove Valve Assembly.
3. Reinstall Power Tube Tip and remove blue Bumper from the Power Tube.
4. Replace blue Bumper with black Bumper.
5. Place Wave Spring on black Bumper.
6. Place Pump Post mount under front of Rail.

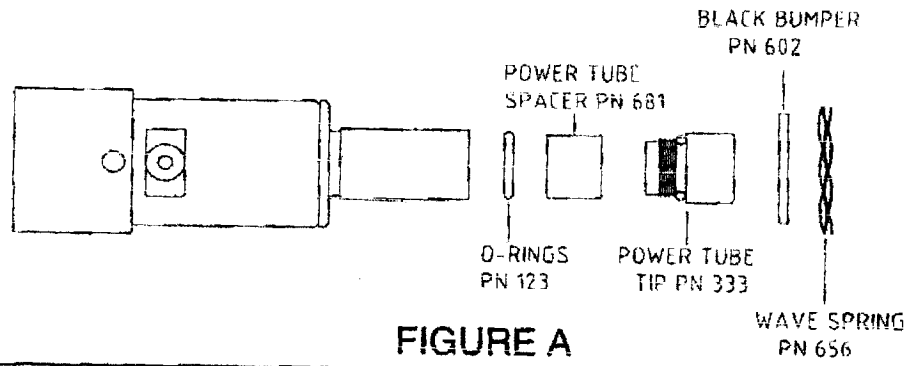

FIGURE A

GUNS WITH VERTICAL BOTTLE ADAPTERS

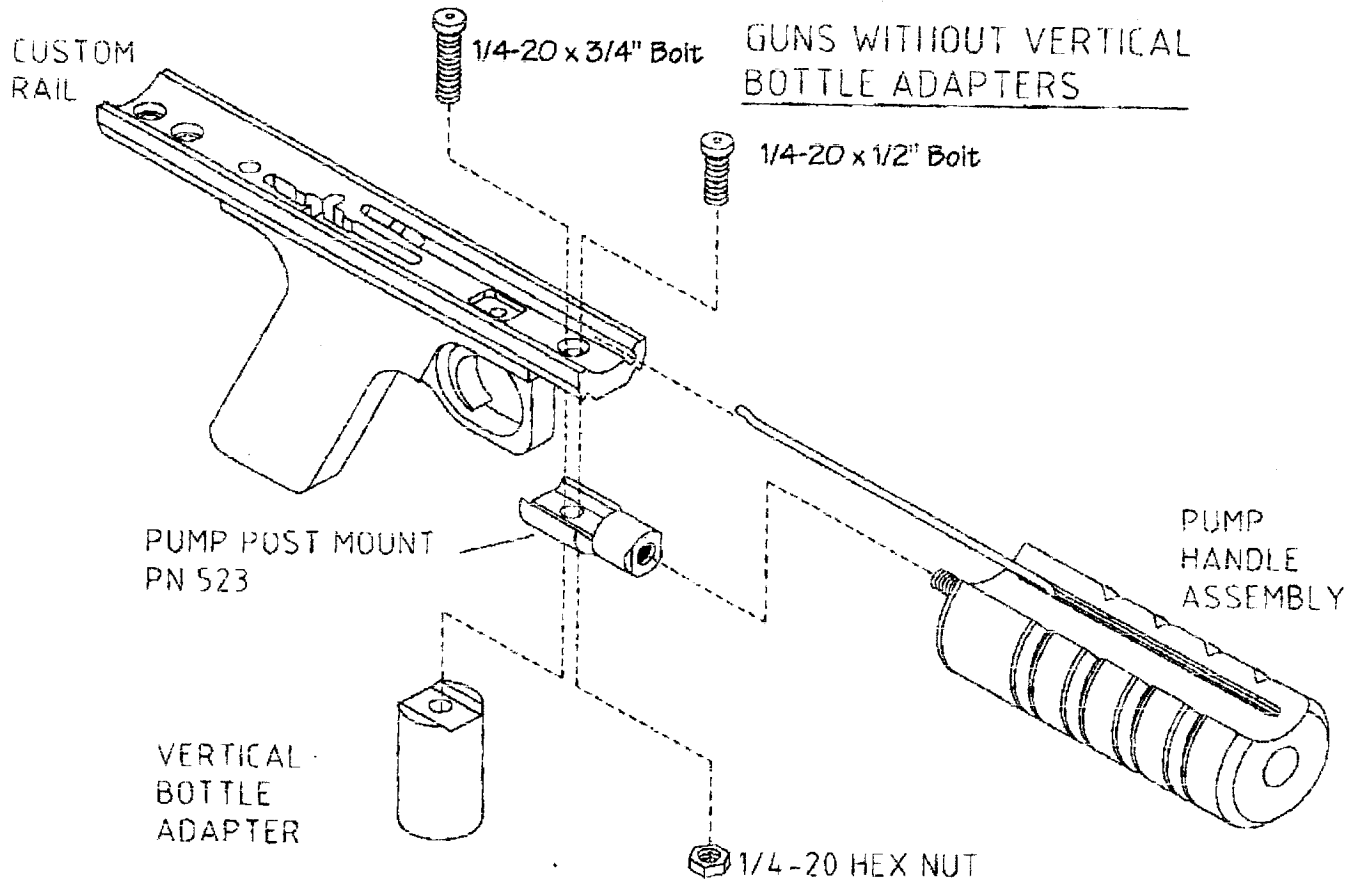

FIGURE B

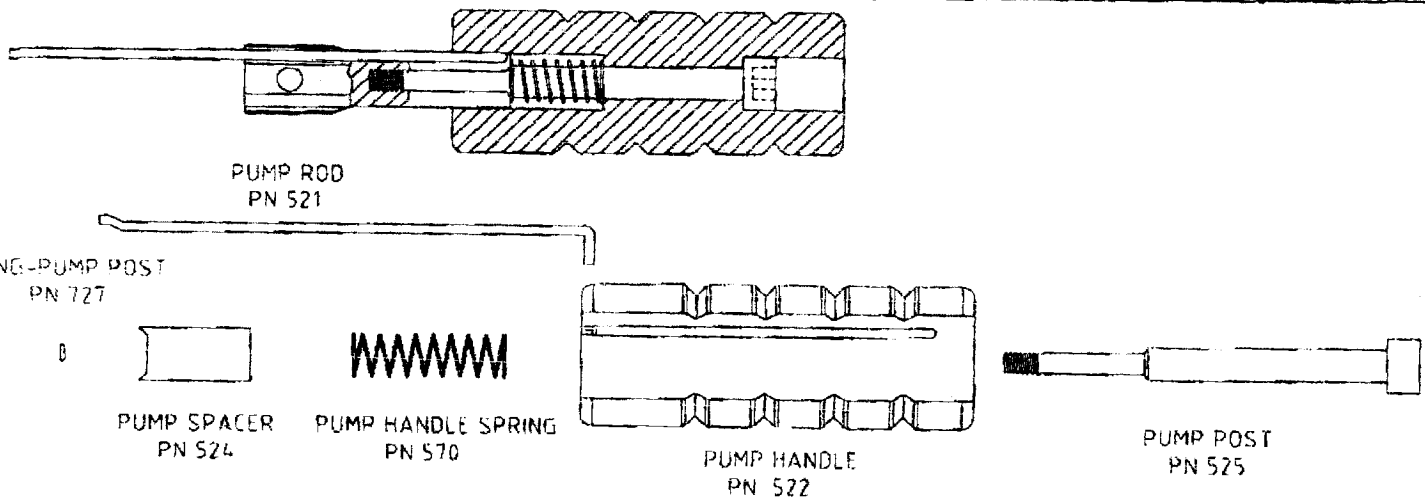
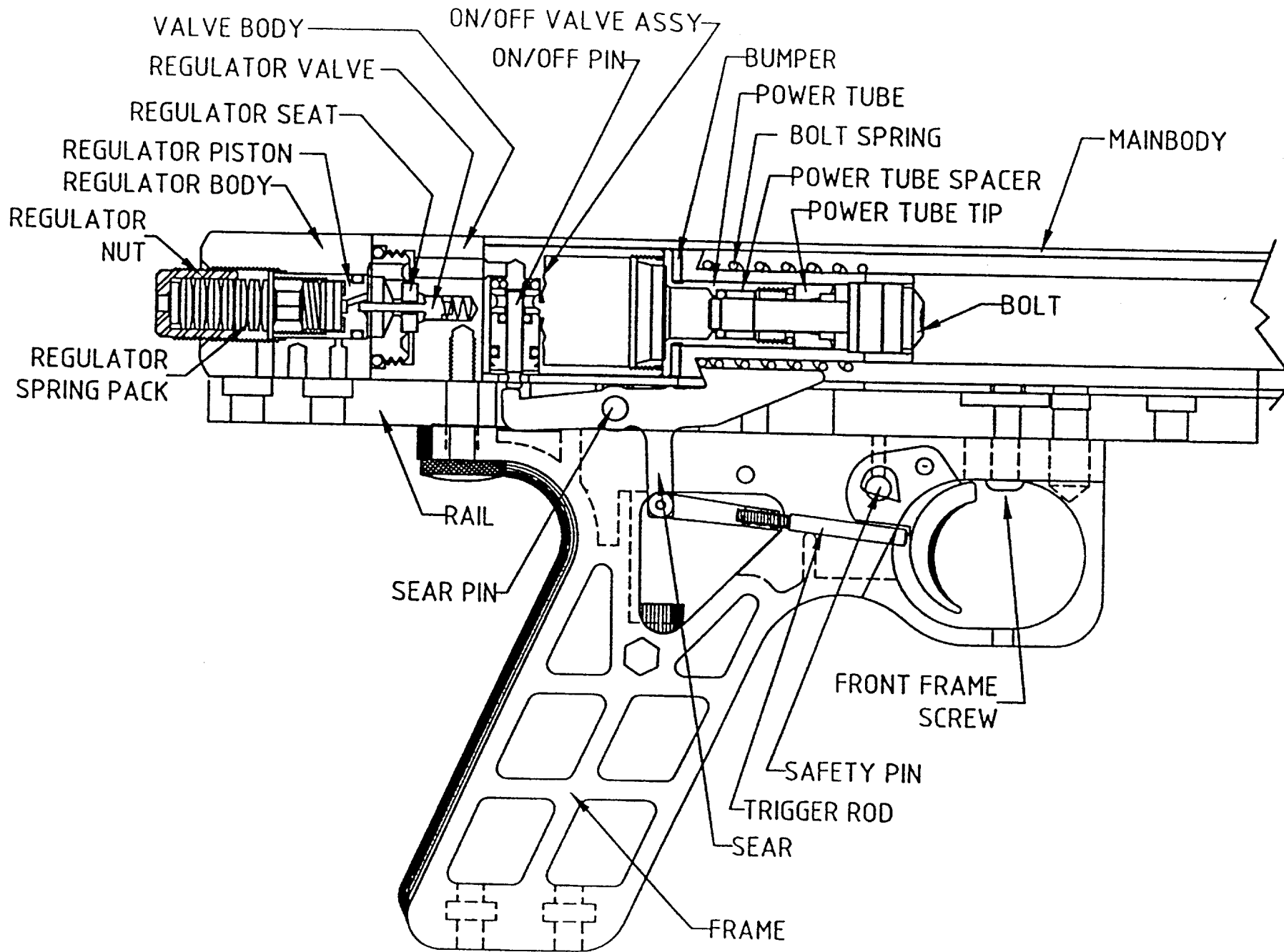
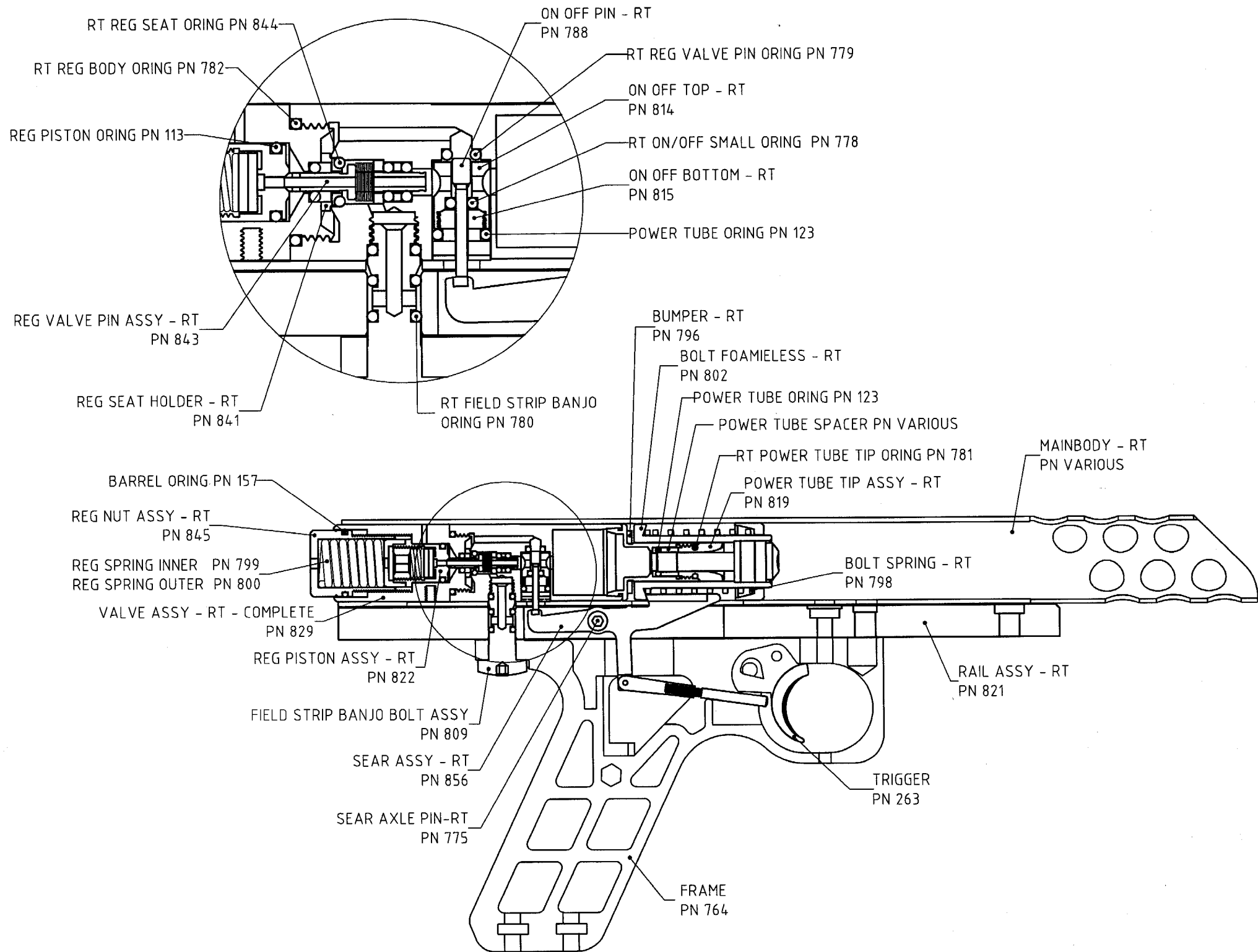

FIGURE C



FUNCTIONAL STEPS

1. AIR TANK SUPPLIES AIR AT 800-1000 PSI TO REGULATOR.
2. REGULATOR TAKES PRESSURE TO 375 PSI.
3. AIR FLOWS THROUGH ON/OFF VALVE AND FILLS AIR CHAMBER
4. TRIGGER IS PULLED, FIRST CLOSING ON/OFF VALVE THEN RELEASING BOLT
5. BOLT MOVES FORWARD AGAINST SPRING PRESSURE UNTIL POWER PISTON EXITS POWER TUBE.
6. AIR IS RELEASED INTO BOLT CAVITY AND FIRES BALL.
7. MAIN SPRING RETURNS BOLT TO COCKED POSITION.
8. TRIGGER IS RELEASED, BOLT IS LATCHED, AND ON/OFF VALVE PRESSURIZES AIR CHAMBER.



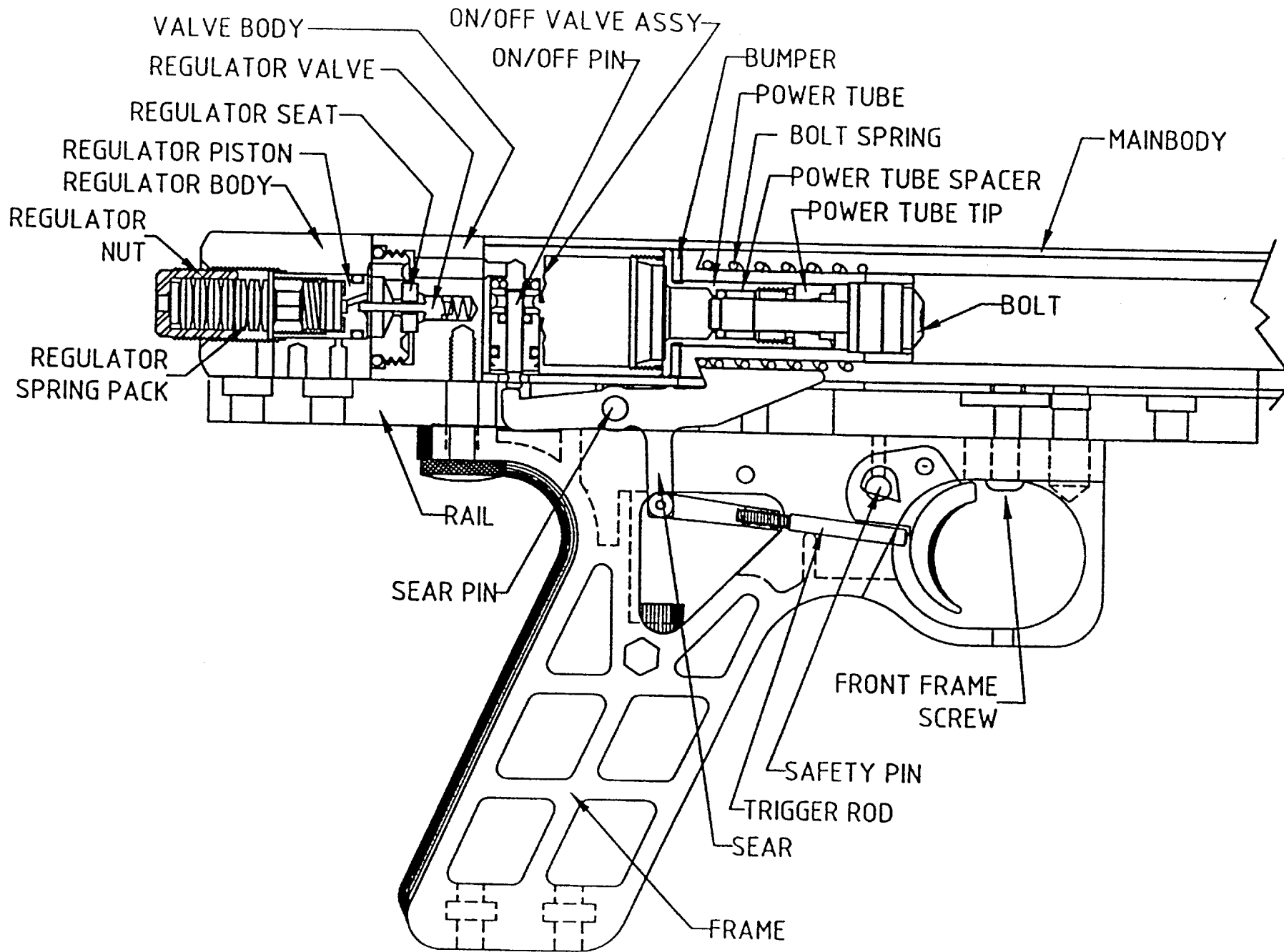

FUNCTIONAL STEPS

1. AIR TANK SUPPLIES AIR AT 800-1000 PSI TO REGULATOR.
2. REGULATOR TAKES PRESSURE TO 375 PSI.
3. AIR FLOWS THROUGH ON/OFF VALVE AND FILLS AIR CHAMBER
4. TRIGGER IS PULLED, FIRST CLOSING ON/OFF VALVE THEN RELEASING BOLT
5. BOLT MOVES FORWARD AGAINST SPRING PRESSURE UNTIL POWER PISTON EXITS POWER TUBE.
6. AIR IS RELEASED INTO BOLT CAVITY AND FIRES BALL.
7. MAIN SPRING RETURNS BOLT TO COCKED POSITION.
8. TRIGGER IS RELEASED, BOLT IS LATCHED, AND ON/OFF VALVE PRESSURIZES AIR CHAMBER.