



iRelay 460 Equipment Installation Guide

Part Number: UGD-D01035

Revision: 1.0

Published: September 2015

© Copyright by **Airspan Networks Inc.**, 2015. All rights reserved worldwide.

Legal Notices

The information contained within this document is proprietary and is subject to all relevant copyright, patent and other laws protecting intellectual property, as well as any specific agreements protecting Airspan Networks Inc. rights in the aforesaid information. Neither this document nor the information contained herein may be published, reproduced or disclosed to third parties, in whole or in part, without the express, prior, written permission of Airspan Networks Inc. In addition, any use of this document or the information contained herein for the purposes other than those for which it is disclosed is strictly forbidden.

Airspan Networks Inc. reserves the right, without prior notice or liability, to make changes in equipment design or specifications.

Information supplied by Airspan Networks Inc. is believed to be accurate and reliable. However, no responsibility is assumed by Airspan Networks Inc. for the use thereof nor for the rights of third parties which may be effected in any way by the use of thereof.

Any representation(s) in this document concerning performance of Airspan Networks Inc. product(s) are for informational purposes only and are not warranties of future performance, either expressed or implied. Airspan Networks Inc. standard limited warranty, stated in its sales contract or order confirmation form, is the only warranty offered by Airspan Networks Inc. in relation thereto.

This document may contain flaws, omissions or typesetting errors; no warranty is granted nor liability assumed in relation thereto unless specifically undertaken in Airspan Networks Inc. sales contract or order confirmation. Information contained herein is periodically updated and changes will be incorporated into subsequent editions. If you have encountered an error, please notify Airspan Networks Inc. All specifications are subject to change without prior notice.

Product performance figures quoted within this document are indicative and for information purposes only.

UK WEE Registration number: WEE/AB0207WZ

Table of Contents

Document Information.....	1
Abstract.....	1
Revision History	1
About This Document	2
Purpose.....	2
Intended Audience	2
Document Conventions.....	2
Document Organization	3
Related Reading	3
Customer Service Help Desk.....	4
Airspan Encourages Comments	4
1 Introduction	5
1.1 iR460 with Internal Steerable Antenna Assembly	5
1.2 Installation Workflow	6
1.3 Installation Checklist.....	7
1.4 Verify Site Requirements.....	7
1.4.1 Commissioning iR460	7
1.4.2 LOS Check.....	7
1.5 Verify Safety Requirements.....	7
1.5.1 Warning of Hazardous Voltages	7
1.5.2 Adhering to European Directive 1999/519/EC	8
1.6 Verify Installation Requirements.....	8
1.6.1 Verify the Tools	8
1.6.2 Verify the Parts and Kits.....	8
1.6.3 Verify Components.....	10
2 Installing iR460.....	11
2.1 Unpacking and Examining iR460	11
2.1.1 iR460 Weights and Dimensions.....	11
2.2 iR460 Assembly	12
2.3 Mounting the iR460 Panel Antenna Unit	13

3	Connecting and Managing the Cables	19
3.1	Fitting the Protection Earth Cable	19
3.2	Lightning Protection	20
3.2.1	Surge Protection Specification	22
3.3	Connecting PoE to iR460	23
3.3.1	RJ45 Pin Connections	23
3.3.2	Weatherproofing the PoE Connectors	23
3.4	Mounting with AirHarmony 1000	25
3.5	Mounting with AirHarmony 4000	26
A	Job Sheet	27
B	Installation Checklist	30
C	Initial Site Survey	31
D	RFI Checklist	33
E	Standard Torque Values – Metric System	35
F	Abbreviations	37

Figures

Figure 1: iR460.....	5
Figure 2: iR460 Installation Workflow	6
Figure 3: Product Dimension Envelope (Wall Mounted).....	12
Figure 4: Product Dimension Envelope (Pole Mounted).....	13
Figure 5: iR460 Mounting Kit Parts	13
Figure 6: Mounting Bracket.....	14
Figure 7: Sliding the Unit.....	15
Figure 8: Sliding the Unit (Close-Up View)	15
Figure 9: Securing the iR460 Unit.....	15
Figure 10: iR460 Mounting Plate	16
Figure 11: Front View of the iR460 Mounting Plate	16
Figure 12: Sliding the iR460 Unit	16
Figure 13: Securing the iR460 Unit.....	17
Figure 14: iR460 Installed on a Large Pole.....	17
Figure 15: Attaching the Mounting Bracket.....	18
Figure 16: iR460 with Earthing Connection	19
Figure 17: Attaching the Earth Cable to the Pole	19
Figure 18: Recommended Metal Combinations	20
Figure 19: iR460 with Internal POE and External Surge Protection and Grounding	21
Figure 20: iR460 with External POE and Grounding	22
Figure 21: RJ45 Cable from PoE to the PoE Port of the Unit.....	23
Figure 22: RJ45 Pin Connections	23
Figure 23: Connecting the Protection Earth and Ethernet Cable.....	24
Figure 24: iR460 with Earth and Ethernet Cables installed	24
Figure 25: Securing the Cables	25
Figure 26: iR460 with AirHarmony 1000 on a Small Pole—Front View.....	25
Figure 27: iR460 with AirHarmony 1000 on a Small Pole—Side View	26
Figure 28: iR460 with AirHarmony 1000 on a Large Pole—Side View.....	26
Figure 29: iRelay with AirHarmony 4000.....	27
Figure 30: Standard Torque Values.....	35

Tables

Table 1. Typographic Conventions.....	2
Table 2. iR460 Panel Antenna Specification	5
Table 3. iR460 Installation Tools	8
Table 4. iR460 Installation Parts and Kits.....	8
Table 5. iR460 IRM Kit.....	9
Table 6. iR460 Components	10

Table 10. Weights and Dimensions of Products and Brackets 11

Table 11. Weights and Dimensions of Brackets..... 11

Table 7. Parts List..... 13

Table 8. Surge Protection Specification 22

Table 9. Network Configuration Information 29

Document Information

Abstract

This document details the procedures for installing the iRelay (iR460) equipment and includes equipment installation best practices. Airspan assumes that the personnel performing these instructions have a basic working knowledge of the equipment.

Revision History

Revision Details	Date	Summary of Changes
Preliminary information	August 2015	Added Appendix (Paul Holmes)
Rev 1.0	September 2015	This guide is a new document that provides instructions for installing iR460.

About This Document

Purpose

This guide provides the workflow and step-by-step procedures for installing the iR460 equipment. It includes the following procedures:

- Verifying prerequisites
- Installing the iR460 radio equipment
- Installing the PSU equipment
- Connecting and managing cables

Intended Audience

This guide is intended for the personnel who install the iR460 equipment. Airspan assumes that a person performing these instructions is qualified in performing installations and capable of identifying hazards.

Document Conventions

This document uses the following typographic conventions.

Table 1. Typographic Conventions

Convention	Element
Blue underlined text	Cross-reference links.
Bold text	Keyboard buttons and GUI elements.
<i>Command</i>	Command names or phrases.
Computer output	Text displayed by the computer.
Hyperlinks	Website and e-mail addresses.
Danger	Signifies a hazardous situation—if not avoided—will cause death or serious injury. Describes how to avoid it.
Warning	Signifies a hazardous situation—if not avoided—can cause death or serious personal injury. Describes how to avoid it.
Caution	Signifies a hazardous situation—if not avoided—can void the product warranty, and cause property damage. Describes how to avoid it.
Important	Provides necessary information to explain a task.
Note	Provides additional information.
Tip	Provides helpful hints.

Document Organization

Chapter	Contents
1 Introduction	Provides an overview of iR460.
2 Installing iR460	Describes how to install an iR460 unit.
3 Connecting and Managing Cables	Provides instructions on how to connect and manage earthing, lightning protector, and power drop cables.
A Job Sheet	Provides information that aids users in performing the installation.
B Installation Checklist	Provides an overview of the high-level steps involved in the installation process.
C Initial Site Survey	Provides the list of requirements that helps you to make sure that the site is ready for equipment installation.
D RFI Checklist	Provides the list of requirements that helps you to prepare for installing an iR460 unit.
E Standard Torque Values – Metric System	Lists standard torque values.
F Torque Setting for Serratub Maxi Steel Bands	Provides information on the recommended torque setting for the Serratub Maxi steel bands.
G Abbreviations	Lists the abbreviations (used in this document) and their expansions.

Related Reading

The following document contains related information:

- ***iRelay 460 Product Specification***

This product specification describes the design requirements and standards of iR460.

Customer Service Help Desk

Airspan's *Customer Care Help Desk* offers prompt and efficient customer support services.

Note: To avail *Airspan's Customer Care Help Desk* support, you must be a registered user and must have a valid support contract. To register, click [here](#) and fill the **Registration** form.

To create and update issue logs, send e-mails to [Customer Care Help Desk](#). Once you submit your issue, the system generates a new issue and sends an issue number for your reference. The system uses this issue number to categorize and store e-mails under the appropriate issue.

To help *Customer Care Help Desk* identify your issue, include the issue number and your *Customer Care Helpdesk* account details in all further communications.

Main Operations

Airspan Communications Ltd.
Capital Point
33 Bath Road
Slough, Berkshire
SL1 3UF, United Kingdom
Tel: +44-1895-467-100

Worldwide Headquarters

Airspan Networks Inc.
777, Yamato Road, Suite 105
Boca Raton, FL 3341-4408, USA
Tel: +1 561 893 8670

Airspan Encourages Comments

Airspan welcomes any feedback and suggestions that help to improve the quality of the documentation. Send your feedback to documentfeedback@airspan.com.

1 Introduction

iRelay 460 (iR460) is part of *iRelay*—Airspan's wireless backhaul family.

iR460 offers the following benefits:

- Provides PtP connectivity.
- Functions as the building blocks that provides fully secure and encrypted capabilities.
- Provides a trusted wireless backhaul solution that supports all capacity needs of Airspan's eNodeB.
- Provides high-speed data.

iR460 contains both radio and antenna as a single unit housed such that the antenna direction can be rotated by software command and by automatic link acquisition software. The complete weatherproof enclosure can be mounted on a wall, pole, or tower, and powered by an AC or a DC PoE device using a CAT5e cable.

1.1 iR460 with Internal Steerable Antenna Assembly

This form factor is targeted for short or medium distance deployments where the feeder base is located on pole mounts (typically, on a lamppost, towers or in a building location).

Figure 1: iR460



Table 2. iR460 Panel Antenna Specification

Item	Specification
Frequency range	LTE B41
Antenna	60°
EIRP	31 dBm (max)
Input power (typical)	< 20 Watt @ Input to PoE
Dimensions (H x W x D)	330 x 200 x 200 mm (excluding cable glands and mounting)
iR460 unit weight	See Table 7
Radome	UV protected polycarbonate
Operating temperature range	-40°C to +65°C
Wind load	200 km/h (survival)

Item	Specification
Water proofing	IP-67

1.2 Installation Workflow

[Figure 2](#) shows the steps involved in the iR460 installation workflow.

Figure 2: iR460 Installation Workflow

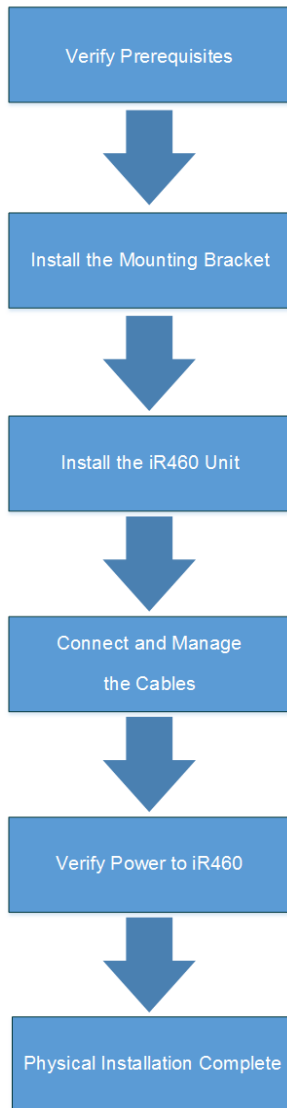

1.3 Installation Checklist

To plan the installation of the iR460 unit, use the installation checklist. See [Appendix B](#).

1.4 Verify Site Requirements

1.4.1 Commissioning iR460

To change or check iR460 values, an Ethernet connection or Bluetooth is required to a laptop PC so that the local web page can be accessed.

1.4.2 LOS Check

For best results it is important to have a clear LOS between iR460 and the DeNB.

To ensure a clear LOS, make sure the following requirements are met:

Note: Make sure to check whether there are any additional obstacles which were not detected during last survey.

1.5 Verify Safety Requirements

Read and follow all warning notices and instructions marked on the product or included in this manual.

When installed in the final configuration, the product must comply with the applicable safety standards and regulatory requirements of the country in which it is installed. If necessary, consult with the appropriate regulatory agencies and inspection authorities to ensure compliance.

Ascertain the radiation hazards and act accordingly when working in an environment close to other antennas and electromagnetic fields—for example, working on towers with other Radio transmitters.

1.5.1 Warning of Hazardous Voltages

On AC installations, hazardous voltages exist. Use caution when verifying or working with the AC power. Before working with the AC power, remove all metal jewellery and accessories (for example—rings, watches, and other metal items). To avoid personal injury or damage to the equipment, do not allow these metal items to come into contact with the AC power.

On DC sections, short circuiting the low voltage, low impedance circuits can cause arcing that might result in burns or eye damage. To avoid shorting DC circuits, remove all metal jewellery and accessories.

Important: Airspan products do not contain hazardous substances (as defined in UK Control of Substances Hazardous to Health Regulations 1989 and the Dangerous Substances Regulations 1990). At the end of any Airspan products life cycle, the customer should consult with Airspan to ensure that the product is disposed of in conformance with the relevant regulatory requirements.

Caution: Any modifications to this device not expressly authorized by the manufacturer can void the users' authority to operate this device.

1.5.2 Adhering to European Directive 1999/519/EC

European Council Recommendation 1999/519/EC details basic restrictions and reference levels on human exposure to electromagnetic fields as advised by the ICNIRP. Adherence to these recommended restrictions and reference levels should provide a high level of protection as regards the established health effects that may result from exposure to electromagnetic fields.

1.6 Verify Installation Requirements

1.6.1 Verify the Tools

[Table 3](#) lists the tools required for the installation.

Table 3. iR460 Installation Tools

Tool	Quantity	Purpose
Flat blade screwdriver	1	For pole straps (large poles)
Wrenches for M8 and M10 hex head screws	1	For securing iR460 to the bracket and bracket to small poles
Large pliers	1	For tightening the cable glands
Knife	1	For stripping the back insulation
Wire cutters	1	For cutting and trimming the electrical wires
Wire strippers	1	For cutting the insulation
Ring terminals crimp tool	1	For fitting the ring terminals (for example, on the ends of the earthing cables)
RJ45 Crimp tool	1	For crimping the RJ45 connectors to the CAT5e cable terminating ends
Laptop PC	1	For commissioning of units and alignment of the PtP links
Optional	As required	<ul style="list-style-type: none"> • Pen • Labeling machine with weatherproof label • Binoculars

1.6.2 Verify the Parts and Kits

[Table 4](#) and [Table 5](#) provide information on the entire set of installation parts and kits.

For information on the correct set of itinary for a use case (for example, an IB-POE-OD-0 is used for an outdoor installation with an AC input), see the *iRelay 460 Configuration Guide (Rev 1.0)*.

Table 4. iR460 Installation Parts and Kits

Product	Part Code	Item Description	Quantity per Install
iR460 unit	IR460-xxxx-xxx-xx	iR460, single Ethernet, PoE input	1
POE+		POE supported from AirHarmony*	

Product	Part Code	Item Description	Quantity per Install
Power Supply	IB-POE-ID-0	iR460 outdoor AC input POE*	
	IR460-POE-DC-OD-0	iR460 outdoor DC input POE*	
Cables	IB-DCCABLE-0	Unterminated DC cable – As required for installation	Xm
	IB-ARM-SWACABLE-P-0	Armored AC mains cable - As required for installation	
	CBL-GND-1M-1	Grounding cable- As required for installation	Xm
	IB-ETH-CAT5EUV-P-0	Shielded CAT5e UV resistant cable - As required for installation	Xm
Label	CABLE-LABELS-0	Labels for cables - As required for installation	N
Pole mounting kit		Mounting kit	1
IRM kit	Not Supplied	Suggested IRM kit (for more details, see Table 5)	1

* Power can be supplied from AirHarmony or PoE devices.

The IRM kit lists the suggested consumable items required to complete a physical installation of each iR460 unit.



Table 5. iR460 IRM Kit

Product	Part Code	Item Description	Quantity per Pack
RJ45 shielded connector	IB-ETH-RJ45CON-P-0	RJ45 shielded connector	2
Grounding lug	CON-LUG-GND-1	Grounding lug one hole for 6AWG cable	1
Cable ties	CABLE-TIES-1	Cable Ties - Black	10
	CABLE-TIES-2	Cable Ties - White	50
PVC tape	PVC-INS-TAPE-1	PVC Tape 4.5m, Black 19mm width, 2m	1
	PVC-INS-TAPE-2	PVC Tape 4.5m, Green 19mm width, 2m	1
DC cable connector kit	IB-DCCON-0	DC Cable Connector Kit	2
Nut	IB-M6-NUT-0	Stainless steel M6 nut	5
Bolt	IB-M6-BOLT-0	Stainless steel M6 bolt	5
Washer	IB-M6-WSHR-0	Stainless steel M6 washer	5
DC cable fork lug	IB-DCLUG-FRL-0	DC Cable Fork Lug	1
Self-amalgamating tape	S-AMAL-WP-TAPE-1	Self-amalgamating waterproof tape - 1m	1

1.6.3 Verify Components

[Table 6](#) lists the iR460 components and accessory kits.

Table 6. iR460 Components

Component Description	Illustration
iR460	
Mounting bracket	
<ul style="list-style-type: none"> • PSU (DC and AC) • Surge protector • Waterproof outdoor PSU enclosure 	

2 Installing iR460

This chapter describes how to install and perform the setup for the iR460 link.

It includes information on the following topics:

- [Unpacking and Examining iR460](#)
- [Mounting the iR460 Panel Antenna Unit to a Pole](#)

2.1 Unpacking and Examining iR460

Before you begin the iR460 install, examine the iR460 package contents carefully before making arrangements for the professional services personnel to install the equipment. Unbox iR460 and inspect it for any physical damage that might have occurred during transportation and storage.

Important: Any physical damage to the iR460 unit must be addressed before mounting the unit at the site.

Verify that all other equipment including cables, tools, mounting brackets, and grounding systems are in place for the installation.

2.1.1 iR460 Weights and Dimensions

[Table 7](#) and [Table 8](#) list the weights and dimensions of the product and brackets.

Table 7. Weights and Dimensions of Products and Brackets

Product and Brackets	Height (inch / mm)	Diameter (inch / mm)	Weight (lbs / kg)
iRelay without brackets	13 inch / 330 mm	7.87 inch / 200 mm	9.85 lbs / 4470 g
iRelay together with a wall bracket	17.20 inch / 437 mm	7.87 inch / 200 mm	10.80 lbs / 4900 g
iRelay together with a small pole bracket	17.40 inch / 442 mm	7.87 inch / 200 mm	12.82 lbs / 5815 g
iRelay together with straps and a 3.7 inch pole bracket	17.40 inch / 442 mm	7.87 inch / 200 mm	12.18 lbs / 5525 g

Note: The values listed in [Table 7](#) do not include the weights and dimensions of the cables and shroud.

Table 8. Weights and Dimensions of Brackets

Brackets	Height (inch / mm)	Width (inch / mm)	Depth (inch / mm)	Weight (kg / lbs)
iRelay wall bracket	7.13 inch / 181 mm	3.15 inch / 80 mm	0.75 inch / 19 mm	0.95 lbs / 430 g
iRelay pole bracket front and rear parts (for poles up to 3.7 inch diameter)	4.17 inch / 106 mm	5.63 inch / 143 mm	1.50 inch / 38 mm	2.02 lbs / 915g

Brackets	Height (inch / mm)	Width (inch / mm)	Depth (inch / mm)	Weight (kg / lbs)
Pole bracket rear part only (for poles up to 3.7 inch diameter)	1.50 inch / 38 mm	4.96 inch / 126 mm	0.98 inch / 25 mm	0.53 lbs / 240 g
iRelay pole bracket and straps (for poles over 3.8 inch diameter)	4.17 inch / 106 mm	5.63 inch / 143 mm	1.50 inch / 38 mm	1.378 lbs / 625 g

2.2 iR460 Assembly

[Figure 3](#) and [Figure 4](#) show the gap required between iR460 and the mounting pole.

Figure 3: Product Dimension Envelope (Wall Mounted)

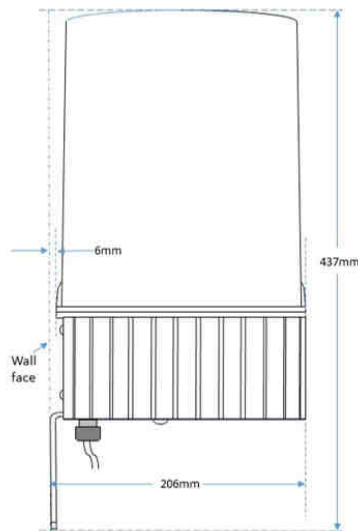
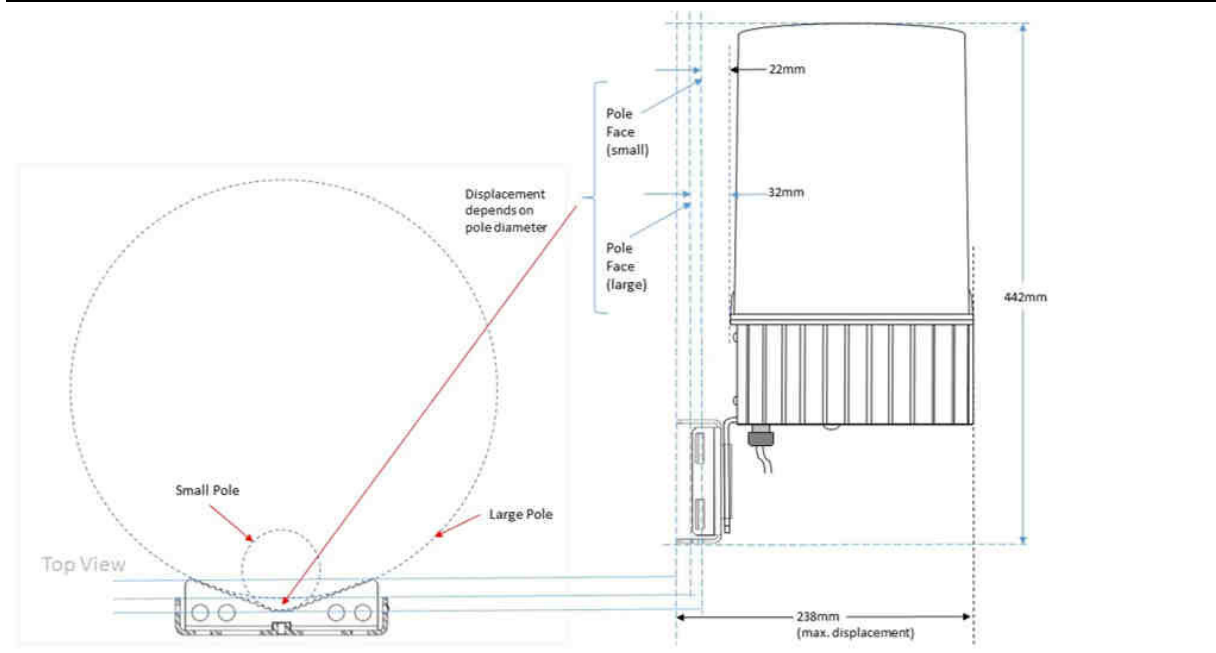

Figure 4: Product Dimension Envelope (Pole Mounted)



2.3 Mounting the iR460 Panel Antenna Unit

When installing iR460 on a pole, mast, or lamppost, use the pole mount kit included with the iR460 unit.

[Figure 5](#) shows iR460 mounting kit parts.

For a description of these parts, see [Table 9](#).

Figure 5: iR460 Mounting Kit Parts



Table 9. Parts List

Item	Quantity	Description
1	2	Long bolts for connecting mounting bracket front and back plates together around the small pole

Item	Quantity	Description
2	1	Mounting bracket back plate (part A)
3	1	Mounting bracket front plate (part B)
4	2	Short bolts for mounting iR460 to the mounting bracket

The iR460 mounting kit that is designed to enable deployment on a wall or a pole contains:

- Wall mounting bracket and short bolts
- Pole mounting bracket part A and long bolts
- Pole mounting bracket part B and metal straps

2.3.1.1 Mounting iR460 to a Pole

When installing iR460 on a pole, mast, or lamppost, use the pole mount kit included with the iR460 unit. Carefully select the location on the pole allowing enough clearance to align the iR460 to the desired direction.

The following are the two types of available pole mounting kits:

- Type A iR460 mounting kit for poles less than 3.75 inch diameter
- Type B iR460 mounting kit for poles less greater than 3.75 inch diameter

Both contain several parts that you can assemble prior to mounting on a pole. For more information on how to mount Type A iR460 and Type B iR460, see [Mounting Type A iR460 for Metal Poles Less than 3.75 inch Diameter](#), [Mounting Type B iR460 for Metal Poles Greater than 3.75 inch Diameter](#), and [Mounting Type B iR460 for Wood Poles Greater than 3.75 inch Diameter \(TBC\)](#).

2.3.1.2 Mounting Type A iR460 for Metal Poles Less than 3.75 inch Diameter

To install iR460 on small poles (that is, poles with diameter up to 3.75 inch), use all brackets parts except the metal bands.

1. Insert both long bolts into the bracket part A; position on the pole, fit bracket Part B, fit the washers (form A washer and rectangular lock washer), hand tighten the nut. Position the bracket in the correct location on the pole before fully securing.

Torque =

Make sure to place part A behind the pole.

Figure 6: Mounting Bracket

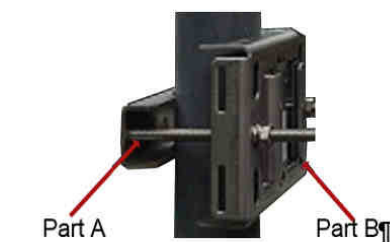

2. Slide iR460 into the pole bracket front slot.

For more information, see [Appendix E, Standard Torque Values – Metric System](#).

2.3.1.3 Mounting Type B iR460 for Metal Poles Greater than 3.75 inch Diameter

To install iR460 on large poles (that is, poles with diameter over 3.75 inch), use all brackets parts except part A and the long bolts.

1. Feed both metal bands through the bracket part B, then fit to the pole. Pull as much as possible through by hand, and then press down the locking mechanism. Correctly position the bracket on the pole before fully securing by tightening the metal bands with 10 mm flat blade screwdriver or a spanner/wrench (16 mm).

Figure 10: iR460 Mounting Plate

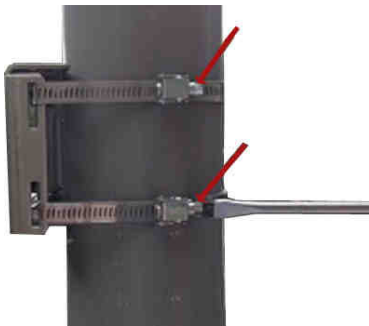

[Figure 11](#) shows the front view of the iR460 mounting bracket installed on a large pole.

Figure 11: Front View of the iR460 Mounting Plate



2. Slide iR460 into the front slot of the pole bracket.

Figure 12: Sliding the iR460 Unit



3. Secure the unit to the bracket with the two bolts (supplied in the mounting kit). Fully secure by tightening the screws with a spanner/wrench (13 mm).

Figure 13: Securing the iR460 Unit



Figure 14: iR460 Installed on a Large Pole



2.3.1.3.1 Torque Setting Large Poles

Torque setting for the steel bands used for mounting iR460 on a large pole should not exceed 3.7 lb ft or 5 Nm.

For more information, see [Appendix F, Torque Setting for Serratus Maxi Steel Bands](#).

2.3.1.4 Mounting Type B iR460 for Wood Poles Greater than 3.75 inch Diameter (TBC)

2.3.1.5 Mounting the iR460 Panel Antenna Unit on a Wall

For wall mounting, perform the following steps:

1. Attach the mounting bracket to the wall using three fixings.

Figure 15: Attaching the Mounting Bracket



Note: Airspan does not supply the screws. Depending on the wall material, choose appropriate screws.

3 Connecting and Managing the Cables

3.1 Fitting the Protection Earth Cable

1. Connect an earthing cable to the screw fixing point on the main body casting of iR460.

The earthing cable must be connected to a protection ground bar or clamped directly to the steel structure of the power or pole. Typically, protective earthing is required in areas of high lightning activity or when the iR460 unit is mounted on high, exposed roofs or tower structures.

For the surge protection devices inside the iR460 unit to be effective, a direct earth connection is required. The earthing cable must be kept as short as possible (typically 0.6m) and the cable must be positioned downwards leading away from iR460, avoiding any sharp bends. (The earthing lugs and screws are supplied in the IRM kit.)

Figure 16: iR460 with Earthing Connection

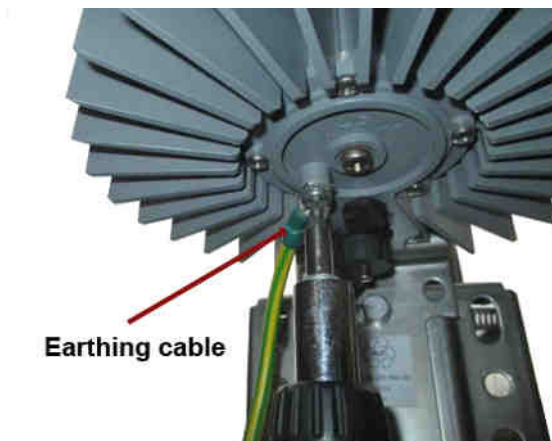

2. Connect the earth cable to the protection earth bar using suitable crimp lugs. Alternatively, use a clamp to join the earth cable to the steel structure of the mounting pole or tower structure (see [Figure 17](#)).

Note: Airspan does not supply the clamp required for this connection. Depending on the tower structure, choose an appropriate clamp.

Figure 17: Attaching the Earth Cable to the Pole

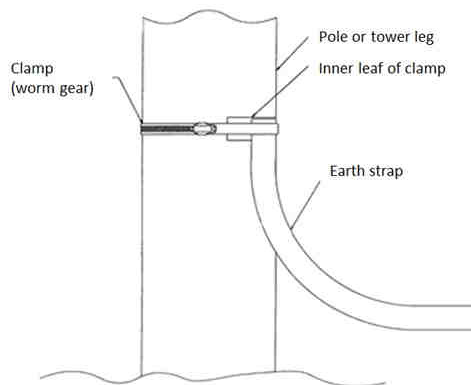

Important: To avoid or minimize galvanic corrosion, when installing a protection earth be sure to use the suitable metal combinations. See [Figure 18](#). Avoid combinations above the

red dividing line.

Figure 18: Recommended Metal Combinations

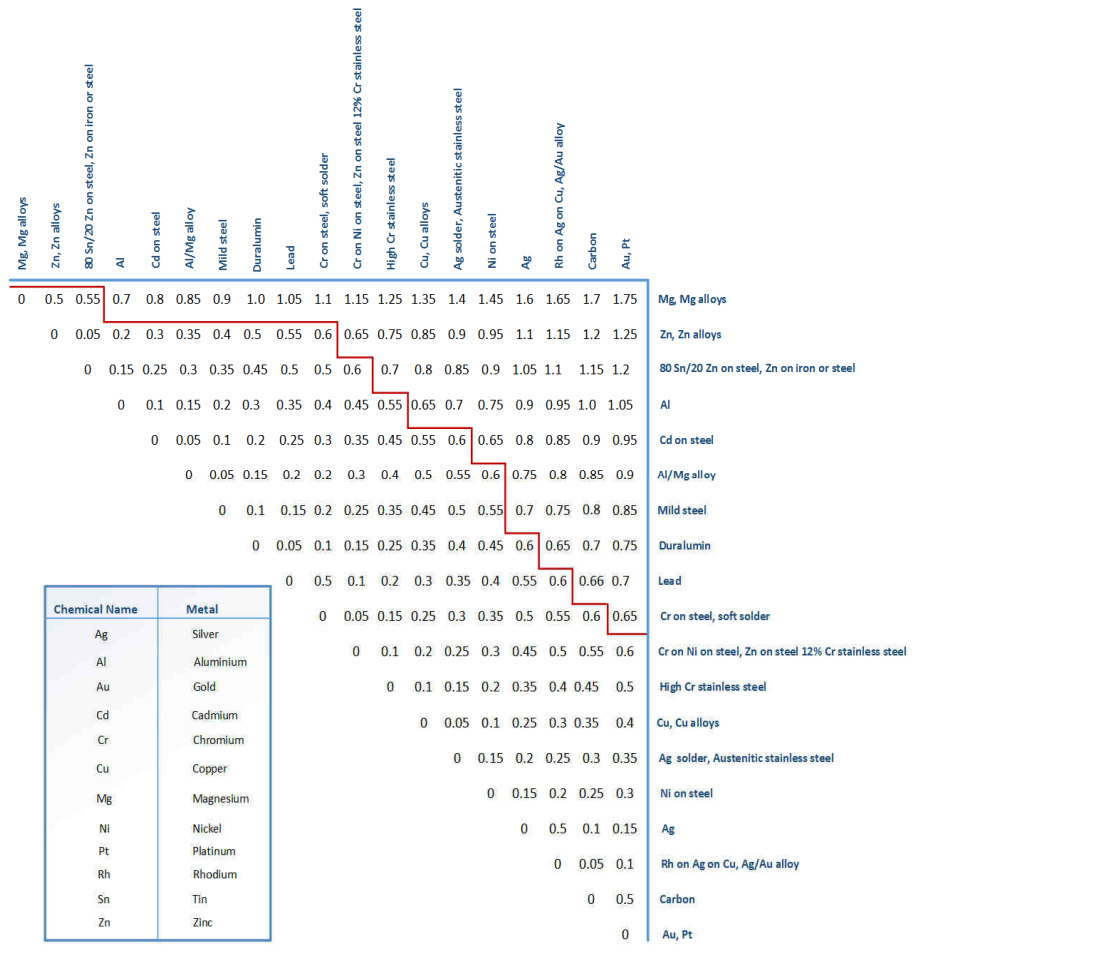

Important: Corrosion due to electrochemical action between dissimilar metals that are in contact can be minimized if the combined electrochemical potential is below 0.6 V. [Figure 18](#) shows the combined electrochemical potentials for a number of pairs of metals that are commonly used. Avoid combinations listed above the red dividing line.

3.2 Lightning Protection

The use of lightning protection depends on the regulatory and end user requirements. To minimize the risk of damage caused by the lightning strikes, iR460 is designed with built-in surge limiting circuits. Airspan recommends to use additional surge protection devices for long exposed cable runs (for example—a cable over 5 m).

Additional surge protector device can be positioned at the building entry point and grounded properly, as illustrated in the figure below.

Airspan recommends to avoid positioning iR460 at the highest point on a structure (for example—the roof of a building, telecoms mast or tower). Ideally you should position the iR460 unit within a lightning protected zone.

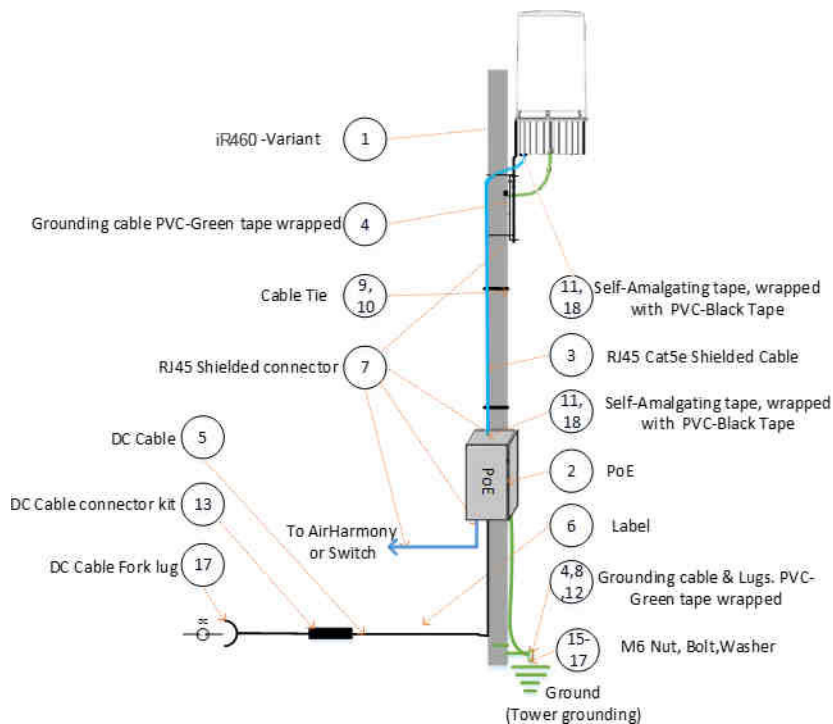
Figure 19: iR460 with Internal POE and External Surge Protection and Grounding

Warning: Failure to meet the safety requirements and use of non-standard practices and procedures can result in personal injury and damage to the equipment. A direct lightning strike might cause serious damage even if these guidelines are followed.

All outdoor wireless equipment is susceptible to lightning damage from a direct hit or induced current from a near strike. Lightning protection and grounding practices in local and national electrical codes serve to minimize the equipment damage, service outages, and serious injury.

A lightning protection system provides a means by which the energy might enter earth without passing through and damaging the parts of a structure. A lightning protection system does not prevent lightning from striking; it provides a means for controlling it and preventing the damage by providing a low resistance path for the discharge of energy to travel safely to the ground. Improperly grounded connections are also a source of noise that can cause a sensitive equipment to malfunction.

To limit the equipment damage caused by a lightning strike to a wireless system, Airspan recommends the following practices:

- Provide a direct grounding from the iR460, and the lightning or surge protectors to the same ground point at the base of the tower or a ground bus on the building. Use the grounding screws on the iR460 unit for terminating the ground wires.
- The AC wall outlet ground must be connected to the same grounding system as iR460.

Figure 20: iR460 with External POE and Grounding

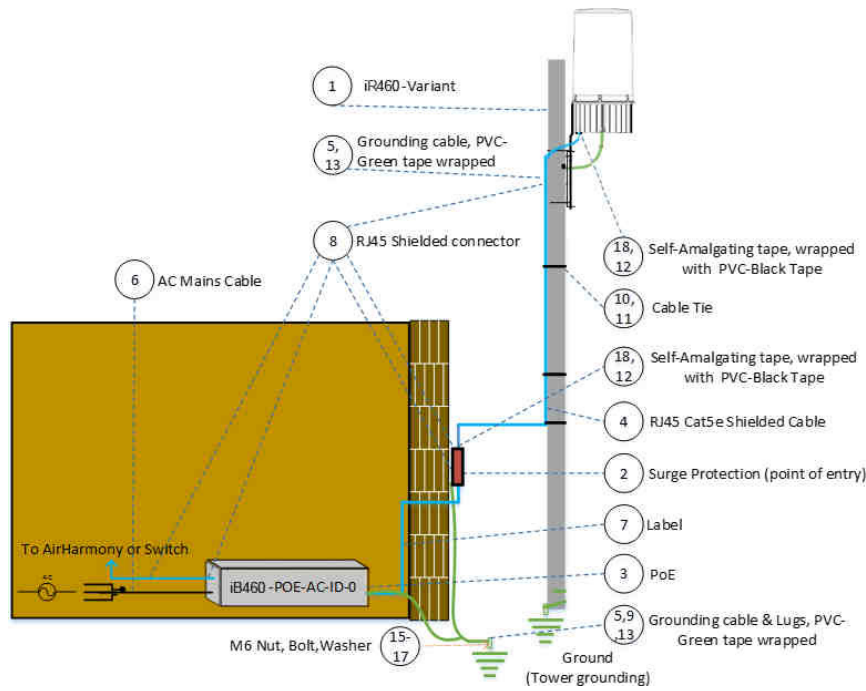

3.2.1 Surge Protection Specification

Table 10 lists the surge protection specification for iR460.

Table 10. Surge Protection Specification

Item	Specification
Operating Voltage	Data 5V ; POE 48V
Clamping Voltage	70V POE (All 8 Pins)
Max Surge Discharge Current	5 KA (8/20 us)
Peak Pulse Current	100 A (10/1000 us)
Protection Mode	Differential & Common Mode
Insulation Resistance	>1000 MOhm
Shunt Capacitance	< 25 pF
Data Rate	10/100/1000 Mbps
Response Time	<5 ns
Operating Temperature	-40 to +85°C
Storage Temperature	-40 to +125°C
Operating Humidity	0% to 95% non-condensing
Size (L x W x H)	4 x 1 x 1" (102 x 25 x 25mm)
Weight	3.1oz (88g)
Ground Wire	14 AWG, 10" (26cm) long
Connectors	RJ45 Shielded Jacks

Item	Specification
IEC Standard	61000-4-5, 61643-21

3.3 Connecting PoE to iR460

The shielded CAT5e UV resistant cable coming from PoE needs to be connected to the iR460 PoE port through a gland.

Figure 21: RJ45 Cable from PoE to the PoE Port of the Unit

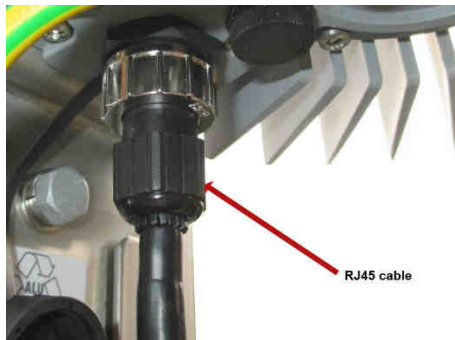

3.3.1 RJ45 Pin Connections <Type B??>

[Figure 22](#) shows the RJ45 pin connections.

Figure 22: RJ45 Pin Connections

Pin	T568A Pair	T568B Pair	Wire	T568A Color
1	3	2	tip	white/green stripe
2	3	2	ring	green solid
3	2	3	tip	white/orange stripe
4	1	1	ring	blue solid
5	1	1	tip	white/blue stripe
6	2	3	ring	orange solid
7	4	4	tip	white/brown stripe
8	4	4	ring	brown solid

Pins on plug face (socket is reversed)

3.3.2 Weatherproofing the PoE Connectors

To weatherproof the connector gland, perform the following steps:

1. Apply a layer of self-amalgamating tape to the weather-exposed connector.
2. Apply a layer of PVC tape to cover the self-amalgamating tape completely. Wrap the PVC tape tightly to avoid any creases or folds that might form traps for water.

Figure 13: Applying the Self-Amalgamating Tape

NEW DIAGRAM NEEDED

Important: Make sure that the PoE connector is completely weatherproofed.

3.3.3 Step-by-Step Cable Installation Overview

1. Insert the RJ45 Male connector (shielded) into the iR460 Ethernet port. Ensure the connector is fully engaged before tightening the IP67 gland.

Figure 23: Connecting the Earthing Cable

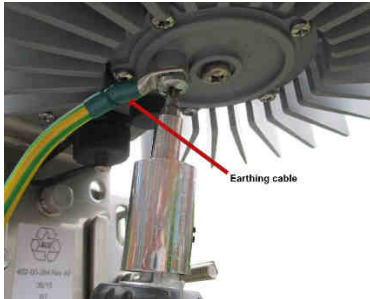

Figure 24: Connecting the Ethernet Cable

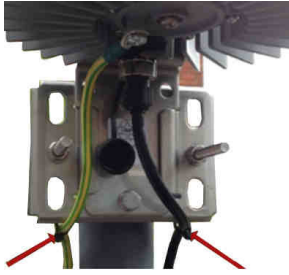

Figure 25: iR460 with Earth and Ethernet Cables Installed



2. Secure the cables to the mounting bracket with zip lock cable ties.

Figure 26: Securing the Cables



3.4 Mounting with AirHarmony 1000

[Figure 27](#), [Figure 28](#), and [Figure 29](#) show the schematic diagram of iRelay with AirHarmony 1000 on a small pole and large pole.

Figure 27: iR460 with AirHarmony 1000 on a Small Pole—Front View

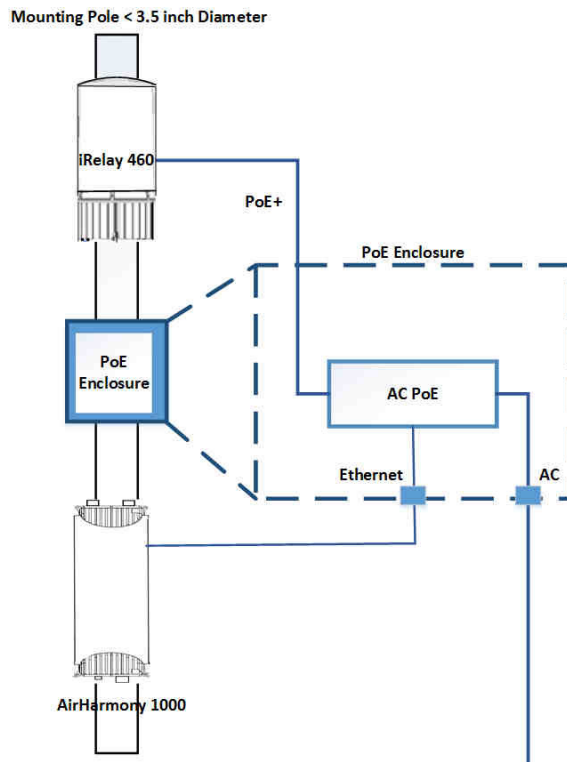

Figure 28. iR460 with AirHarmony 1000 on a Small Pole—Side View

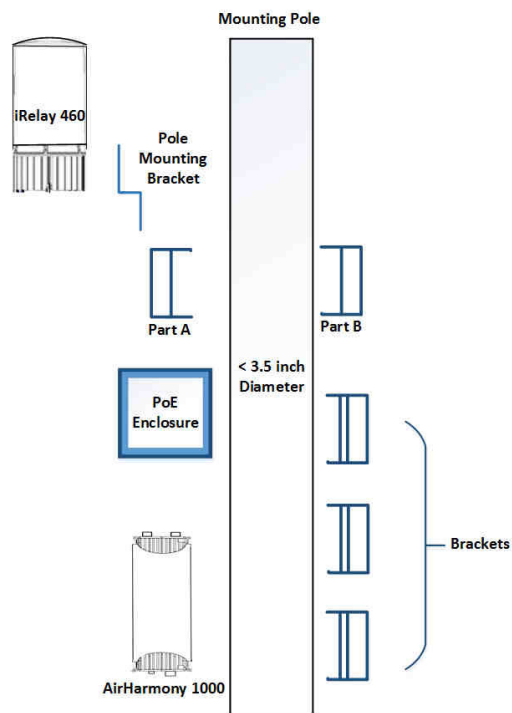
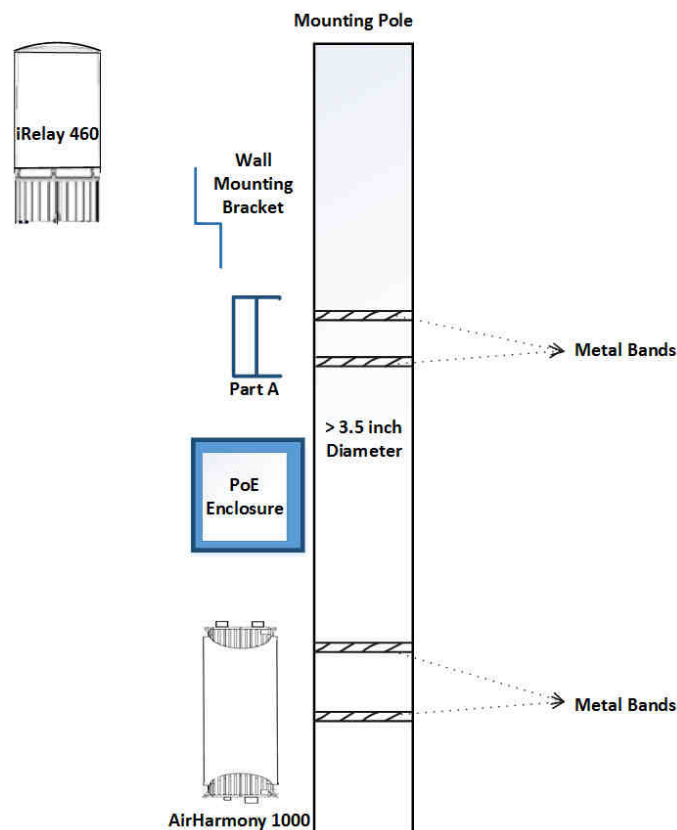

Figure 29. iR460 with AirHarmony 1000 on a Large Pole



3.5 Mounting with AirHarmony 4000

Figure 30 shows the schematic diagram of iRelay with AirHarmony 4000.

Figure 30. iRelay with AirHarmony 4000

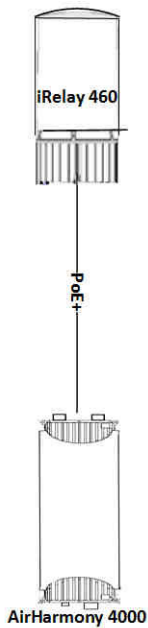

A Job Sheet

This job sheet enables the equipment installer to keep track of their installations. It contains all the information required for accomplishing the iR460 installation.

Required information
<ul style="list-style-type: none"> ○ Identified mounting assets (pole, tower, or wall) for installation ○ Position on the mounting asset ○ Pole access restrictions (for example—highway regulations, other services on the pole, power pole, and so on) ○ Method of reaching the pole positions (for example—ladders or elevated work platform) ○ Available AC main fuseway for the PSU ○ Identified configuration programming details ○ Point of connection for Ethernet (if applicable) Anniversary
Equipment available at the installation site
<ul style="list-style-type: none"> ○ Main iR460 unit ○ Mounting bracket ○ PSU ○ PoE injector (with fixing kit) ○ Ethernet cable assembly
Required tools
<ul style="list-style-type: none"> ○ Large flat screwdriver for pole clamps ○ Small flat screwdriver for DC PoE power terminations

- wrenches for main unit mounting fixings
- Side cutters
- Wire strippers
- Ring terminals crimp tool

Required ancillary equipment

- Laptop PC for initial configuration
- Ethernet cable for temporary connection of the laptop

Other items
<ul style="list-style-type: none"> ○ Self-amalgamating tape ○ Black PVC tape ○ Cable ties ○ Pen ○ Labeling machine with weatherproof label ○ Binoculars

[Table 11](#) lists the network configuration information.

Table 11. Network Configuration Information

Parameter	Description	Parameter Value
IP Address		
Netmask		
Default Gateway Address	See Management IP Mode .	
Management VLAN		
Management VLAN Tag		
Management IP Mode		
Ethernet Mode		
Ethernet Rate		
Ethernet Duplex		

B Installation Checklist

During installation, review and perform all the steps on this checklist (in the given order). This checklist is meant for the person who performs the iR460 installation. It includes the high-level steps involved in the installation process.

Tip: To make sure you complete all the tasks, detach or print this checklist and use it as a job aid. After performing, check off each task.

Procedure	Action	Check If Performed
Verify the prerequisites	Verify site requirements.	<input type="checkbox"/>
	Verify safety requirements.	<input type="checkbox"/>
	Verify installation requirements.	<input type="checkbox"/>
Install the iR460 mounting bracket	Install the mounting bracket.	<input type="checkbox"/>
	Verify connection torque settings.	<input type="checkbox"/>
Install iR460 on the mounting bracket	Fit and secure the iR460 unit to the mounting bracket.	<input type="checkbox"/>
Connect and manage cables	Connect the protection earth.	<input type="checkbox"/>
Connect power system	Connect the iR460 Ethernet cable.	<input type="checkbox"/>
	Connect the PSU.	<input type="checkbox"/>
	Connect power to PoE	<input type="checkbox"/>
	.	<input type="checkbox"/>

C Initial Site Survey

During initial site survey, review all details in the following checklist. It lists the details of parameters and items that need to be confirmed before the equipment installation.

No	Survey Details	Comments		
1	Site Details			
1.1	Site name			
1.2	Site ID			
1.3	Site address			
1.4	Site GPS coordinate (DD MM SS)	Latitude		
		Longitude		
1.5	AMSL			
1.6	Site type	<input type="checkbox"/> Tower <input type="checkbox"/> Pole <input type="checkbox"/> Building <input type="checkbox"/> Other Other:		
1.7	Access details to the site			
1.8	Contact details of the site engineer			
1.9	Type of the terrain	<input type="checkbox"/> Smooth <input type="checkbox"/> Mountainous <input type="checkbox"/> Average		
1.10	Climate	<input type="checkbox"/> Humid <input type="checkbox"/> Dry <input type="checkbox"/> Average		
1.11	Required annual availability	<input type="checkbox"/> 99% <input type="checkbox"/> 99.9% <input type="checkbox"/> 99.99%		
2	Electrical			
2.1	Type of power supply	<input type="checkbox"/> AC <input type="checkbox"/> DC		
2.2	Location of the power point			
2.3	Location for PoE			
2.4	PoE to power source distance			
2.5	PoE to iR460 distance			
3	Earthing/Grounding			
3.1	Earth connectivity is point	Radio	PoE	Surge
		<input type="checkbox"/> Yes	<input type="checkbox"/> Yes	<input type="checkbox"/> Yes
		<input type="checkbox"/> No	<input type="checkbox"/> No	<input type="checkbox"/> No

4	Tower/Pole	
4.1	Antenna height above the ground level	
4.2	Cable trays installed for cable routing (if applicable)	
4.3	Availability of space for pole mount bracket for iR460.	
4.4	Is there a pole mounted in the allocated space?	<input type="checkbox"/> Yes <input type="checkbox"/> No
4.5	Pole mount diameter	
5	Cable/Length Estimate	
5.1	Length of the Cat5e cable required at site	
5.2	Length of the power cable required at site	
5.3	Length of the grounding cable	
6	Remarks	
<u>Details of the Survey Engineer</u>		
Name: _____		
Mobile No: _____		
Visit No: _____		
Reason for the visit: _____		
Signature: _____		
Date: _____		

D RFI Checklist

Before installation, review all details in the following checklist. It lists the details of parameters and items that need to be gathered before the equipment installation.





No	Site Readiness Details	Comments
1	Site Details	
1.1	Site name	
1.2	Site ID	
1.3	Site address	
1.4	Site GPS coordinate (DD MM SS)	Latitude
		Longitude
1.5	Site type	<input type="checkbox"/> Tower <input type="checkbox"/> Pole <input type="checkbox"/> Building <input type="checkbox"/> Other Other:
1.6	Access details to the site	
1.7	Contact details of site engineer	
1.8	Permission for installation	
1.9	IP plan available	
1.10	Transmission plan available	
1.11	Link budget available	
2	Electrical	
2.1	Type of power supply	<input type="checkbox"/> AC <input type="checkbox"/> DC <input type="checkbox"/> No power
2.2	Location of the power point	
2.3	Isolation switch installed	<input type="checkbox"/> Yes <input type="checkbox"/> No
2.4	MCB installed with power connectivity	<input type="checkbox"/> Yes <input type="checkbox"/> No
2.5	Location for PoE	
2.6	PoE to power source distance	
2.7	PoE to iR460 distance	
3	Earthing/Grounding	
3.1	Earth connectivity is available	<input type="checkbox"/> Yes <input type="checkbox"/> No
3.2	Earth of tower/pole verified	<input type="checkbox"/> Yes <input type="checkbox"/> No
3.3	Cable trays are earthed (if applicable)	<input type="checkbox"/> Yes <input type="checkbox"/> No
4	Tower/Pole	
4.1	Tower/pole height as per survey report	

4.2	Cable trays installed for cable routing (if applicable)	
4.3	Tower climbing ladder installed properly (if applicable)	
4.4	Pole mounts are installed on the tower at required heights and Azimuth	
4.5	Availability of space for pole mount bracket (if pole mount is not installed)	
4.6	Pole mount are fixed properly	<input type="checkbox"/> Yes <input type="checkbox"/> No
4.7	Pole mount diameter (1-4")	
5	Cable/Length Estimate	
5.1	Length of the Cat5e cable required at site	
5.2	Length of the power cable required at site	
5.3	Length of the grounding cable	
6	Remarks	
<u>Details of the Survey Engineer</u>		
Name: _____		
Mobile No: _____		
Visit No: _____		
Reason for the visit: _____		
Signature: _____		
Date: _____		

E Standard Torque Values – Metric System

Use the following table (from http://electronicfilters.tpub.com/TM-10-4330-237-13P/css/TM-10-4330-237-13P_105.htm) to determine the maximum safe torque for a particular size or grade fastener.

Figure 31: Standard Torque Values

<u>STANDARD TORQUE VALUES - METRIC SYSTEM</u>											
In the absence of specific torque values, the following chart can be used as a guide to the maximum safe torque for a particular size/grade of fastener. There is no torque difference for fine or coarse threads. Torque values are based on clean, dry threads. Reduce value by 10% if threads are oiled before assembly.											
Relative Strength Marking		4.6		4.8		8.8 or 9.8		10.9		12.9	
Bolt Markings											
Dia.	Wrench Size	Maximum Torque		Maximum Torque		Maximum Torque		Maximum Torque		Maximum Torque	
		lb ft	Nm	lb ft	Nm	lb ft	Nm	lb ft	Nm	lb ft	Nm
M3	5.5mm	.3	.5	.5	.7	1	1.3	1.5	2	1.5	2
M4	7mm	.8	1.1	1	1.5	2	3	3	4.5	4	5
M5	8mm	1.5	2.5	2	3	4.5	6	6.5	9	7.5	10
M6	10mm	3	4	4	5.5	7.5	10	11	15	13	18
M8	13mm	7	9.5	10	13	18	25	26	35	33	45
M10	16mm	14	19	18	25	37	50	55	75	63	85
M12	18mm	26	35	33	45	63	85	97	130	111	150
M14	21mm	37	50	55	75	103	140	151	205	177	240
M16	24mm	59	80	85	115	159	215	232	315	273	370
M18	27mm	81	110	118	160	225	305	321	435	376	510
M20	30mm	118	160	166	225	321	435	457	620	535	725
M22	33mm	159	215	225	305	435	590	620	840	726	985
M24	36mm	203	275	288	390	553	750	789	1070	926	1255
M27	41mm	295	400	417	565	811	1100	1154	1565	1353	1835
M30	46mm	402	545	568	770	1103	1495	1571	2130	1837	2490

F Torque Setting for Serratub Maxi Steel Bands

Figure 32: Serratub Maxi Steel Band



Airspan uses Serratub Maxi Steel Bands (part number: *MAXI 1 W2B 50-215*) for mounting iR460 on a large pole. [Figure 33](#) provides information on the recommended torque setting for these steel bands.

Figure 33: Recommended Torque Settings

LARGHEZZA NASTRO 9 MM - BAND WIDTH 9 MM

Ø MM	COPPIA SERRAGGIO RACCOMANDATA MM REG. TIGHTENING TORQUE NM MAXI 1	COPPIA SERRAGGIO RACCOMANDATA MM REG. TIGHTENING TORQUE NM MAXI 2
50-110	3	4
50-130		
50-145		
50-165		
50-175		
50-215		
50-280		
50-325		
50-370		
50-425		
60-525		
70-625		

VEDERE CACCIAVITE ESAGONALE PAGINA 11.

LARGHEZZA NASTRO 12 MM - BAND WIDTH 12 MM

Ø MM	COPPIA SERRAGGIO RACCOMANDATA MM REG. TIGHTENING TORQUE NM MAXI 1/W2B
50-110	5
50-130	
50-145	
50-165	
50-175	
50-215	
50-280	
50-325	
50-370	
50-425	
60-525	
70-625	

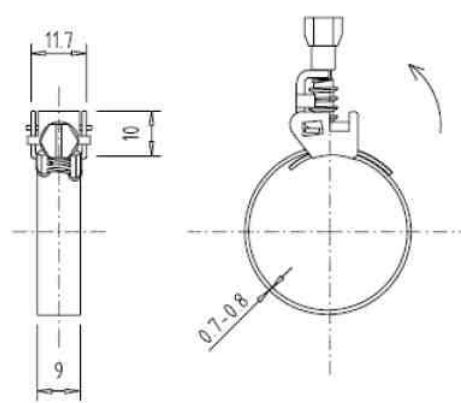

Maxi 2
Ref. MA 9 + Ø MAX + MATER.
Ex. MA 9 110 W1

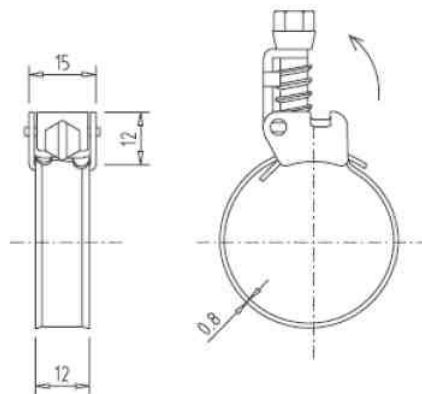

Maxi 1
Ref. MA 9 + Ø MAX + MATER.
Ex. MA 9 110 W1
Ex. MA 12 110 W4

G Abbreviations

Term	Expansion
AC	Alternating current
AMSL	Above mean sea level
CE	European Conformity
DC	Direct current
DeNB	Donor eNodeB
EC	European Council
EIRP	Effective isotropic radiated power
FB	Feeder base
FT	Feeder terminal
GPS	Global Positioning System
ICNIRP	International Commission of Non-Ionizing Radiation Protection
IP	Internet Protocol
iR460	iRelay 460
IRM	Installation related material
LOS	Line-of-sight
MCB	Miniature circuit breaker
PC	Personal computer
PoE	Power over Ethernet
PSU	Power supply unit
PtMP	Point to multipoint
PtP	Point to point
RFI	Ready for Installation
SEM	Screw and washer assemblies
Tx	Transmit
UV	Ultraviolet