



Installing the SPR

This chapter describes the installation of the WipLL **Subscriber Premises Radio (SPR)**, located at the subscriber's premises.



Warning: Cables with exposed ends (i.e., not yet crimped) should be covered with protective polythene bags during external cable installation processes.



Warning: As the system emits microwave radiation, a minimum distance of 200 mm must be maintained from the front of the SPR. However, for the 700 MHz band (i.e. WipLL 700), when external antennas are used, a minimum distance of 800 mm must be maintained from the front of the device.



Warning: To avoid electrical or fire hazard, connect the SPR to the power supply only after mounting the SPR and connecting data cables.



Note: Usually, the SPR is initialized (i.e., configured with an IP address) at Airspan's factory. However, if the SPR has not been configured, see Section 10.5, "Connecting to a PC for Serial Configuration", before mounting the SPR.



Note: The digital portion of the transceiver has been tested and found to comply with the limits for a Class B digital device, pursuant to part 15 of the FCC rules. These limits are designed to provide reasonable protection against harmful interference in a residential installation. This equipment generates, uses, and can radiate radio frequency energy and, if not installed and used in accordance with the instructions, may cause harmful interference to radio communications. However, there is no guarantee that interference will not occur in a particular installation. If this equipment does cause harmful interference to radio or television reception, which can be determined by turning the equipment on and off, the user is encouraged to try correct the interference by performing one or more of the following measures:

- Reorientate or relocate the receiving antenna
 - Increase separation between the equipment and receiver
 - Connect the equipment to an outlet on a circuit different from that to which the receiver is connected
 - Consult the dealer or an experienced radio/TV technician for help
-
-



Note: A minimum separation of 200 mm should exist between power and data cables.

10.1. Physical Dimensions and Basic Design

The SPR is encased in a chassis and provides access to the SPR's communication port (15-pin D-type) at the front panel (see figure below). The SPR's bottom panel provides holes for mounting the SPR to, for example, a pole or wall.



Figure 10-1: SPR (with built-in antenna)

The SPR's physical dimensions are described in the following table.

Table 10-1: SPR physical dimensions

Parameter	SPR model		Comment
	Standard Gain Antenna	High Gain Antenna	
Height	311 mm (12.24 inches)	400 mm (15.74 inches)	The SPR's physical dimensions exclude the mounting kit. SPR models with an N-type receptacle for attaching a third-party external antenna are also available.
Width	224 mm (8.82 inches)	317 mm (12.48 inches)	
Depth	65.5 mm (2.58 inches)	65.5 mm (2.58 inches)	
Weight	2.5 kg	4.7 kg	

10.2. Mounting the SPR

The SPR can be mounted on a wall or pole. The SPR is mounted using the mounting holes located on the SPR's bottom panel (see Figure 10-2), and the mounting bracket (provided). The mounting brackets for wall- and pole mounting are different from one another.

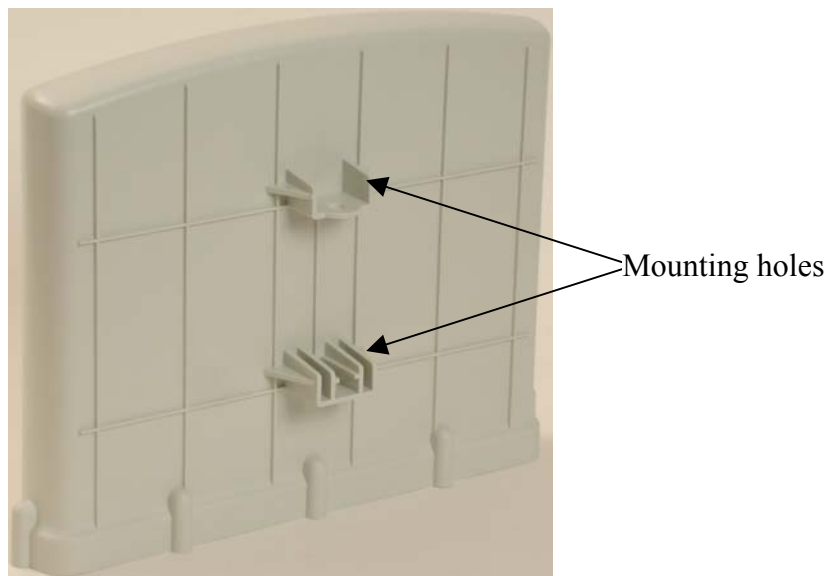

Figure 10-2: SPR bottom panel providing holes for mounting

10.2.1. Minimum Distance between SPRs

A minimum of 3-meter separation is required between mounted SPRs and existing customer radio equipment when not transmitting on the same sector (see Figure 10-3).

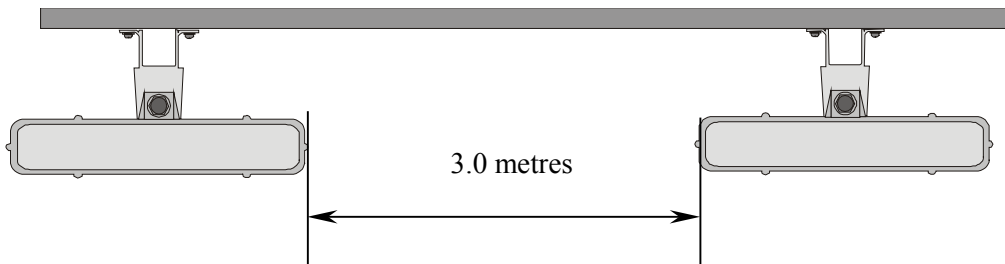

Figure 10-3: SPR separation when not transmitting on the same sector

A 1-meter separation is required between SPRs when on the same sector and transmitting to the same BSR without requiring shielding (see Figure 10-4).

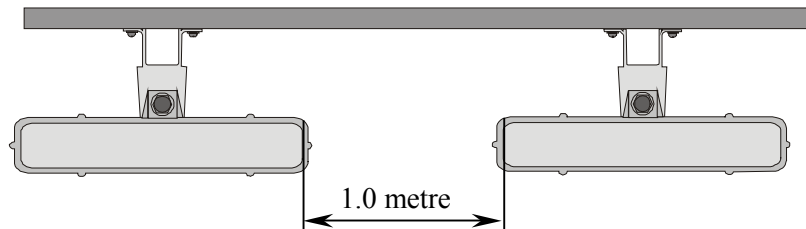

Figure 10-4: SPR separation when transmitting on the same sector to the same BSR

10.2.2. Wall-Mounting

SPR wall mounting is performed in two stages:

- Attaching the mounting bracket to the SPR's mounting holes.
- Attaching the mounting bracket (attached to the SPR) to the wall.

To mount the SPR on a wall:

1. Position the mounting bracket on the mounting surface (e.g., wall), and then use a pencil to mark the position of the four mounting holes.
2. Drill holes for each hole that you marked in the step above.
3. Insert wall anchors into each of the drilled holes.
4. Align the mounting bracket's four holes with the wall anchors, and then insert a screw through the mounting bracket holes into each wall anchor, and tighten.

The figure below displays relevant dimensions of the mounting bracket. Note the two different sized fixing holes.

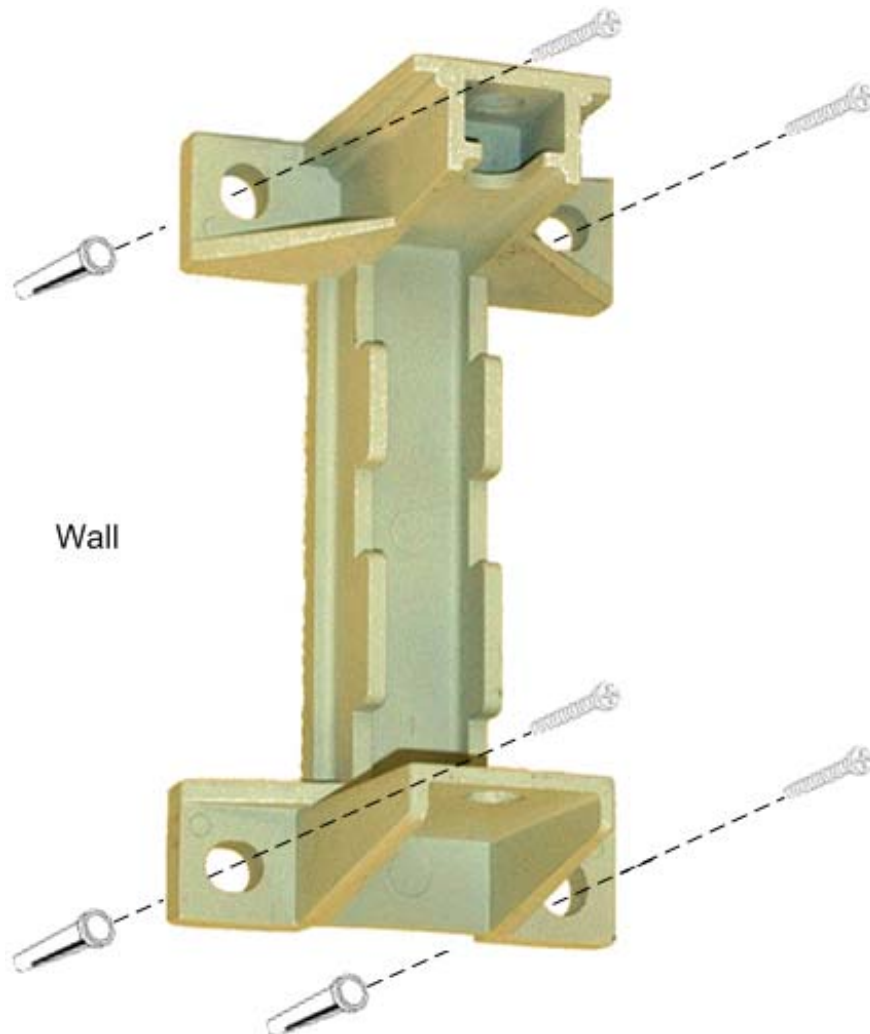
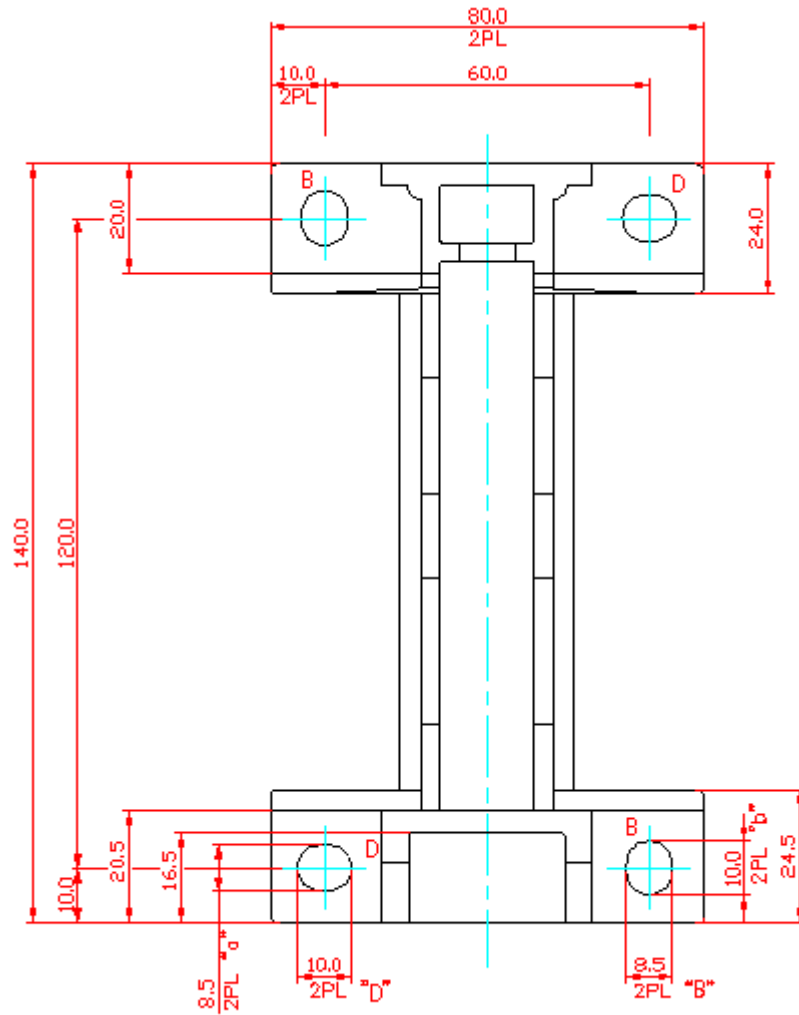

Figure 10-5: Attaching mounting bracket to wall

Below is a diagram illustrating the fixing dimensions of the mounting bracket. Ensure that the distance between the hole centers are 120 mm and 60 mm.



All dimensions in millimeters (mm)

Figure 10-6: SPR mounting bracket dimensions for the four fixing holes

5. Attach the SPR to the mounting bracket using the two stainless steel bolts (supplied), washers, and nuts as shown in the figure below.

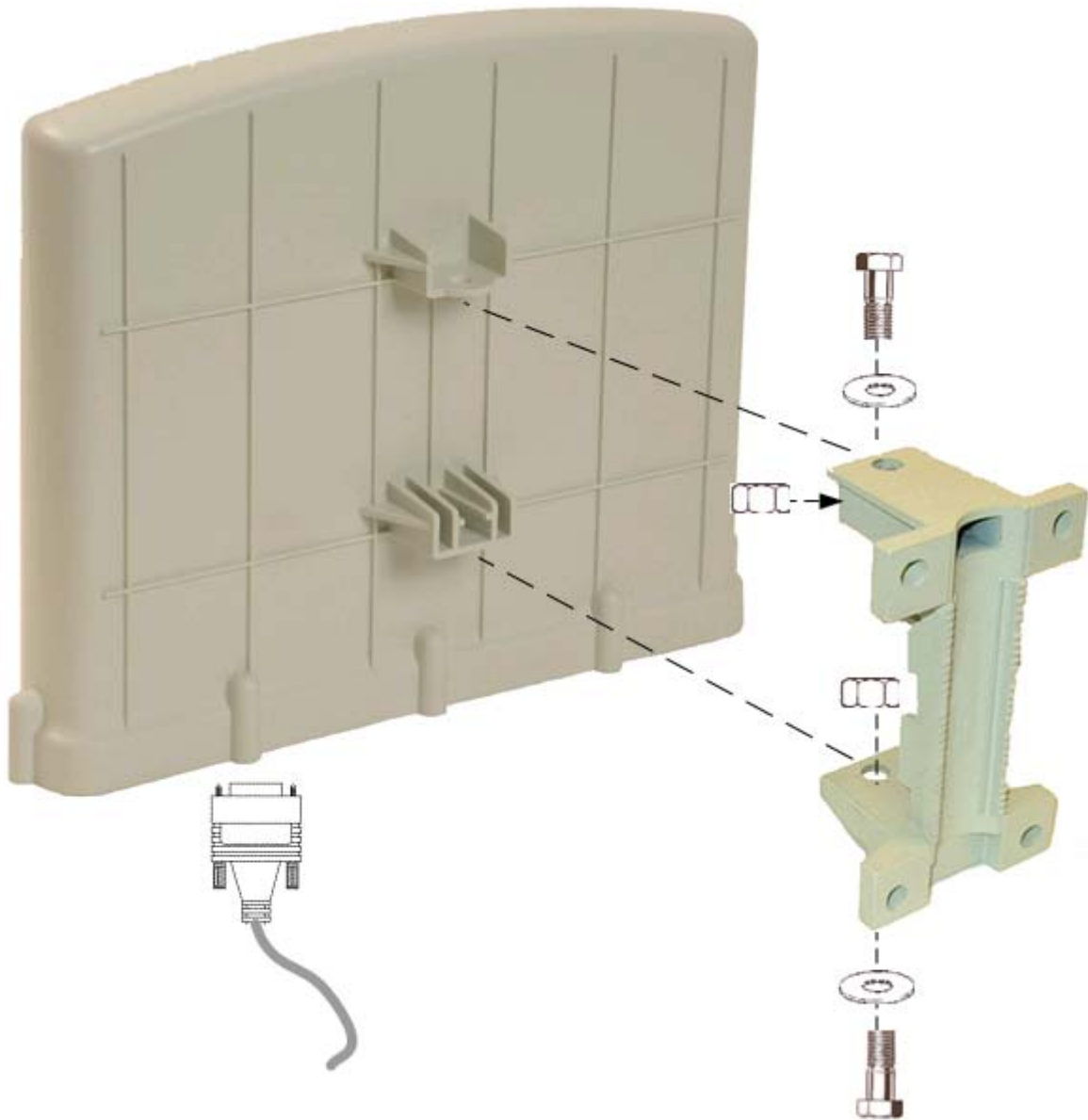

Figure 10-7: Attaching SPR to mounting bracket



Note: Airspan does not provide screws for attaching the mounting bracket to the wall. The screw size depends on the structure of the building to which the bracket is to be attached. When selecting screw sizes, consideration must be given to the weight of the SPR and load that may be induced in windy conditions.

6. Adjust the horizontal positioning of the SPR, and then tighten the two stainless-steel bolts.

Rotation is restricted to the horizontal plane only. The permissible rotation is shown in Figure 10-8.

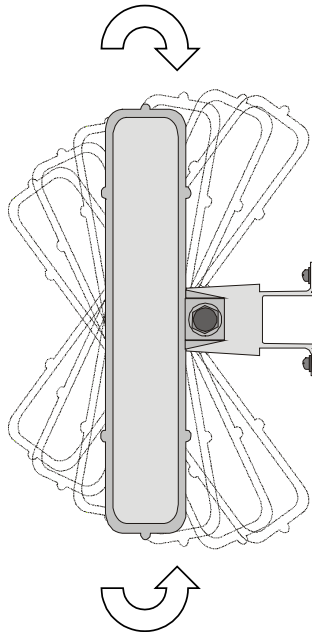

Figure 10-8: Horizontal rotation of the SPR



Note: A thread-locking compound is to be used to prevent the bolts working loose.

10.2.3. Pole-Mounting

The SPR can be mounted on a pole (see Figure 10-9). Pole mounting allows the SPR to be adjusted in the horizontal as well as the vertical plane. The pole-mounting bracket assembly is designed to support the SPR on a round pole of 45 mm in diameter.



Figure 10-9: Mounted SPR

To mount the SPR on a pole:

1. Attach the mounting bracket to the SPR using two stainless steel bolts.

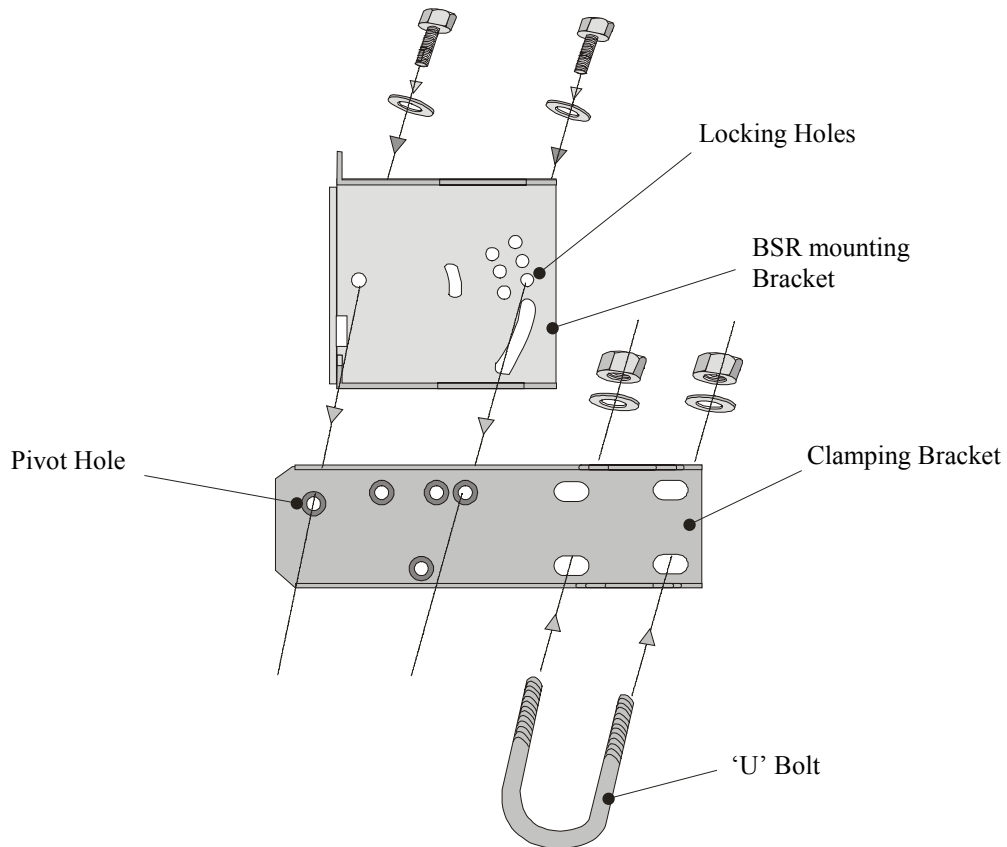

Figure 10-10: SPR mounting bracket assembly

2. Attach the clamping bracket to the mounting bracket using two M8 stainless bolts.
3. Attach the Clamping bracket to the pole by placing the U-bolt around the pole, and then inserting the U-bolt through the Clamping bracket and securing it by screwing the two bolts on the U-bolt.

4. Adjust the vertical position of the SPR. Lock the SPR at the desired position by inserting the locking bolt in the desired position. Once the correct angle has been set both bolts must be tightened to lock the SPR bracket in place.
5. Adjust the horizontal position of the SPR by rotating the SPR about the pole, and then tighten the U-bolt.

SPR positioning is obtained in two planes by adjustment of the mounting bracket assembly as shown in Figure 10-11.

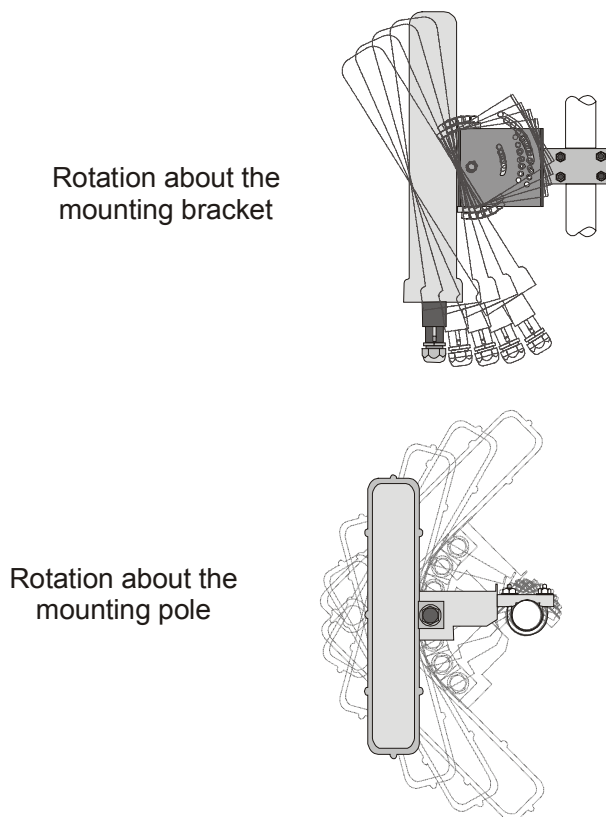

Figure 10-11: SPR GPS orientation in vertical (top) and horizontal plane (lower)



Note: A thread-locking compound is to be used to prevent the bolts working loose. A loop should be left in the cable for maintenance purposes and to prevent the cable weight being taken directly on the connector.

10.2.4. Aligning Using the RSS LED Adapter

You can align the SPR (or third-party antenna) using Airspan's RSS LED Adapter once the SPR has established a wireless link with the BSR.

The RSS LED Adapter indicates the received signal strength (RSS) between the SPR and the BSR. This allows you to accurately position the SPR during installation for optimal radio frequency signal reception.

The RSS LED adapter connects between the SPR and SDA by a CAT 5 cable. The RSS LED adapter provides two 15-pin D-type ports: one for the SPR side, and the other for the SDA side.

The following table lists the RSS LED Plug adapter dimensions:

Table 10-2: RSS LED adapter dimensions

Parameter	Dimensions
Height	123 mm (4.84 inches)
Width	68 mm (2.68 inches)
Depth	30 mm (1.18 inches)
Weight	85g

The RSS LED adapter can be connected in one of the following manners:

- One end connects directly to the SPR's 15-pin D-type port, while the other end connects to the SDA through a CAT 5 cable.
- Both ends (i.e., 15-pin D-type ports) connect to the SPR and SDA through a CAT 5 cable.

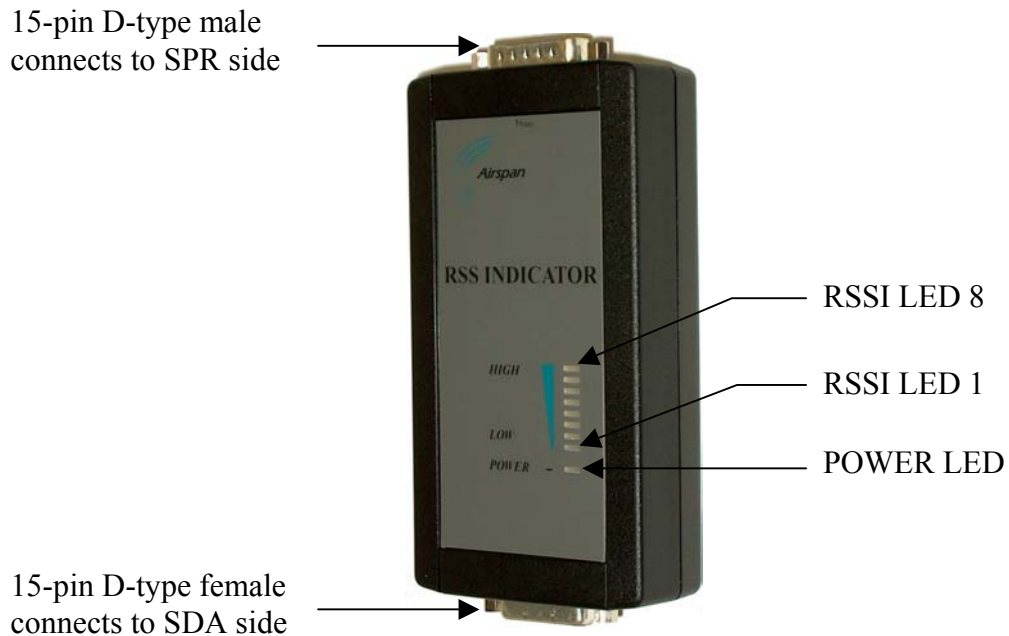

Figure 10-12: RSS LED adapter

The following describes the RSS LED adapter's cable setup:

- **Cables:** two straight-through cables for SPR-to-RSS LED adapter, and for SDA-to-RSS LED adapter.
- **Connectors:**
 - **SPR side:** 15-pin D-type male (only 9-pins used)
 - **RSS LED adapter:**
 - SPR side: 15-pin D-type female
 - SDA side: 15-pin D-type male
 - **SDA side:** 15-pin D-type male

To connect the RSSI LED adapter (see Figure 10-13):

1. Connect the **15-pin D-type male** connector, at one end of the straight-through cable, to the SPR.
2. Connect the **15-pin D-type female** connector, at the other end of the straight-through cable from the SPR, to the RSS LED adapter.
3. Connect the **15-pin D-type male** connector, at one end of the straight-through cable, to the SDA.
4. Connect the **15-pin D-type male** connector, at the other end of the straight-through cable from the SDA, to the RSS LED adapter.

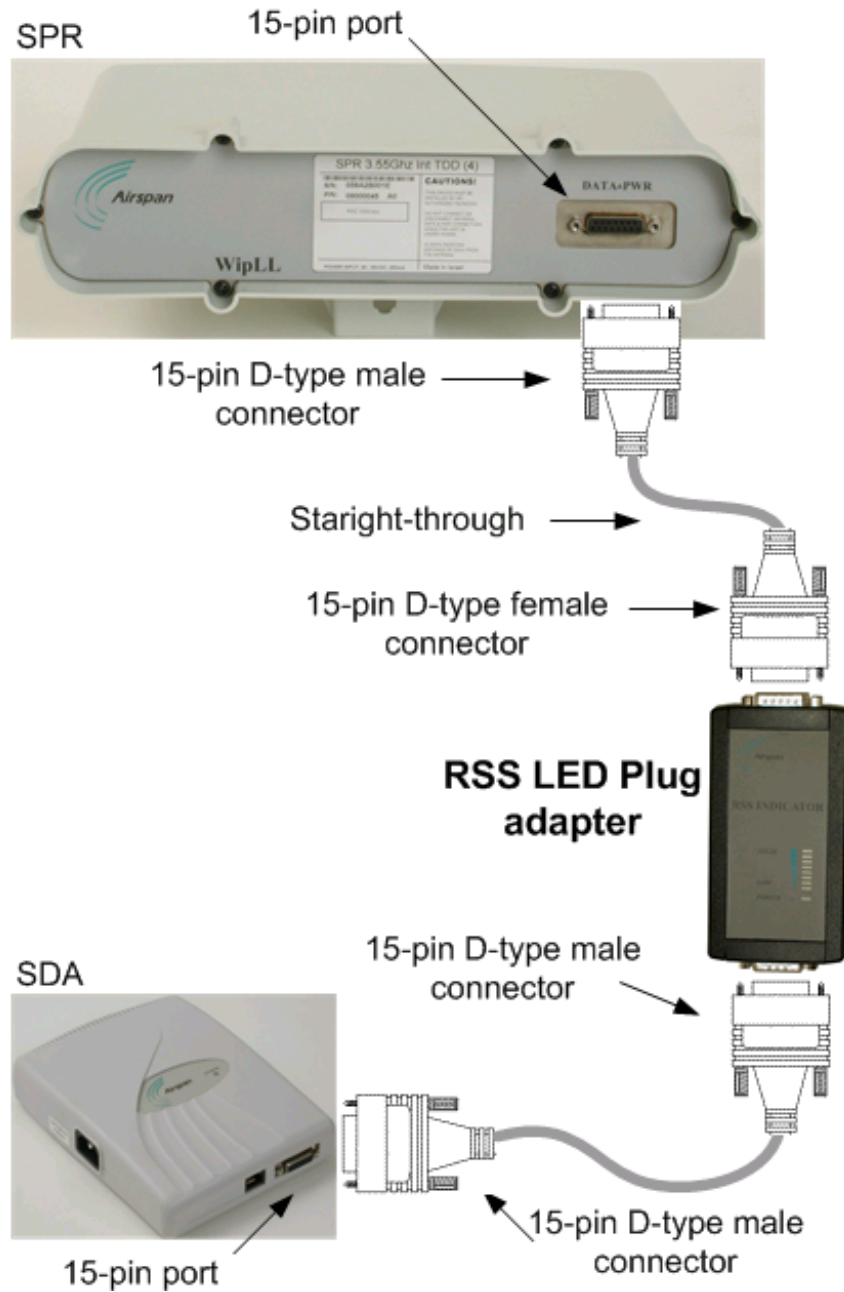

Figure 10-13: Connecting the RSS LED Plug adapter



Note: You can connect the RSS LED adapter's 15-pin male port directly to the SPR's 15-pin female port, instead of using a cable.

Table 10-3 describes the LEDs on the RSS LED adapter.

Table 10-3: LED description of the RSS LED adapter

LED	Color	Function	Status	Description
Power	Red	Power	On	The SPR receives power from the SDA
			Off	No power is supplied to the SPR by the SDA
			Blinking	Data transmission is occurring on the Ethernet LAN
RSS LEDs (LEDs 1 to 8)	Green	Received Signal Strength level	LED 1 blinking	$RSS \leq -94$ dBm
			LED 1 is on	-93 dBm \leq RSS \leq -90 dBm
			LEDs 1 and 2 are on	-89 dBm \leq RSS \leq -86 dBm
			LEDs 1, 2, and 3 are on	-85 dBm \leq RSS \leq -82 dBm
			LEDs 1, 2, 3, and 4 are on	-81 dBm \leq RSS \leq -78 dBm
			LEDs 1, 2, 3, 4, and 5 are on	-77 dBm \leq RSS \leq -74 dBm
			LEDs 1, 2, 3, 4, 5, and 6 are on	-73 dBm \leq RSS \leq -70 dBm
			LEDs 1, 2, 3, 4, 5, 6 and 7 are on	-69 dBm \leq RSS \leq -66 dBm
			All LEDs are on	$RSS \geq -65$ dBm



Note: A smaller number indicates a stronger signal because the RSS level is given as a **negative** value.

10.3. Connecting External Third-Party Antenna (Optional)

The SPR model with an N-type connector can be connected to an external antenna. The addition of an external antenna allows greater RF sector coverage than the standard SPR internal antenna models (i.e., 60°).

- **Cable:** RF coaxial
- **Connector:** N-type male



Warning: Before connecting the external antenna, ensure that the SPR is NOT connected to the power source.



Warning: Before powering on the SPR, ensure that some type of equipment such as an antenna or an RF attenuator is connected to the N-type receptacle. This eliminates the risk of burning the SPR device.



Warning: It is the responsibility of the person installing the WipLL system to ensure that when using the outdoor antenna kits in the United States (or where FCC rules apply), that only those antennas certified with the product are used. The use of any antenna other than those certified with the product is expressly forbidden in accordance with FCC rules CFR47 part 15.204. The installer should configure the output power level of antennas according to country regulations and per antenna type.



Warning: In accordance with FCC regulations, ensure that for external antennas, the maximum EIRP is 36 dBm. The EIRP is defined as:
Max. Power Output + Antenna Gain + Cable Loss ≤ 36 dBm (EIRP)

To connect the SPR to an external antenna:

- Attach an **N-type male** connector of the third-party antenna to the N-type receptacle located on the SPR's front panel.

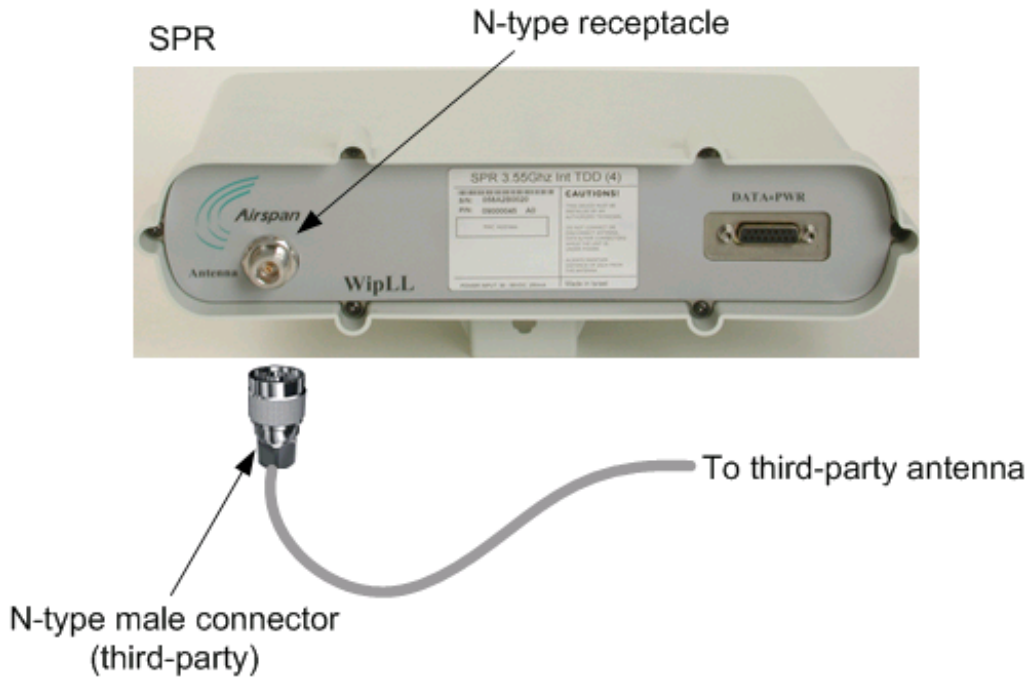

Figure 10-14: SPR model with N-type connector for attaching an external antenna



Note: Airspan supplies unterminated cables for N-type connectors. Refer to Appendix B, "Cable Crimping" for N-type cable crimping.

10.4. Connecting to the SDA

The SPR’s power supply and connectivity to the subscriber’s Ethernet network is provided by the SDA. To connect the SPR to the SDA, you need to connect the SPR’s 15-pin D-type port to the SDA’s 15-pin D-type port using a CAT-5 cable.

The SPR-to-SDA cable setup is as follows:

- **Cable:** straight-through 10Base-T Ethernet UTP 4 Pair **CAT-5e** 24 AWG outdoor type (100 meters)
- **Connectors:**
 - **SPR side:** 15-pin D-type male (only 8 pins are used)
 - **SDA side:** 15-pin D-type male (only 8 pins are used)



Note: Airspan supplies unterminated CAT-5e cables. For a detailed description on crimping cables, see Appendix B, “Cable Crimping”.

- **Connector pinouts:**

Table 10-4: SPR-to-SDA CAT 5 cable connector pinouts

Straight-through CAT-5 UTP PVC 4 Pair 24 AWG cables							
15-pin D-type male	SPR		Wire color	Wire pair	SDA		15-pin D-type male
	Pin	Function			Pin	Function	
	1	+48 VDC	Blue / White	1	1	+48 VDC	
	2	-48 VDC	Blue		2	2	
	3	Tx+	Orange / White	2	3	Rx+	
	4	Tx-	Orange		4	Rx-	
	5	Rx+	Green / White	3	5	Tx+	
	6	Rx-	Green		6	Tx-	
	7	Sync.+	Brown / White	4	7	Sync.+	

	8	Sync.-	Brown		8	Sync.-	
--	---	--------	--------------	--	---	--------	--



Notes:

- 1) Pins 9 through 15 of the 15-pin D-type connector are not used.
- 2) The wire color-coding described in the table is WipLL's standard for wire color-coding. However, if you implement your company's wire color-coding scheme, ensure that the wires are paired and twisted according to the pin functions listed in Table 10-4 (e.g., Rx+ with Rx-).

WipLL uses the following wire color-coding standard for CAT 5 cables (8 wires used) connecting the outdoor radio units to the indoor Ethernet hubs or switches:

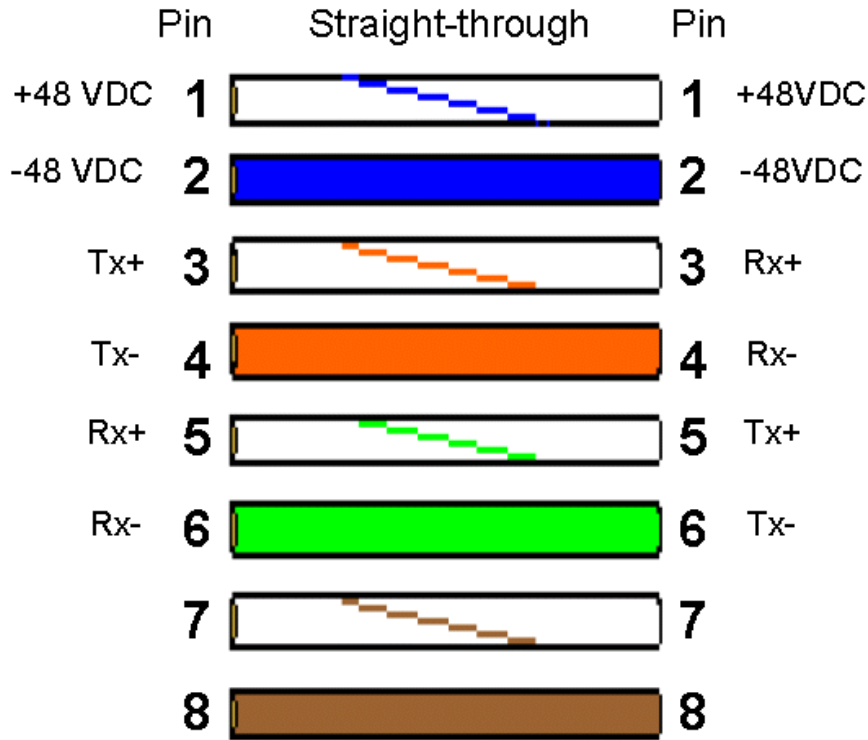

Figure 10-15: WipLL wire color-coding for 15-pin D-type connectors



Warning: To avoid electrical shock, before connecting the SPR to the SDA, ensure that the SDA is not connected to the power supply.



Notes:

- 1) The wires are twisted together in pairs, for example, blue/white with blue, and orange/white with orange. This prevents electrical interference between the transmitter pins. For example, pin 3 (Tx+; orange / white) is paired and twisted with pin 4 (Tx-; orange).
 - 2) The SDA connector pinouts are the same for all SDA models (SDA-1, SDA-4H, SDA-4S, SDA-4S/VL, SDA-4S/Vltag, SDA-4S/1H3L, and SDA-4S/VL/1H3L).
-
-

To connect the SPR to the SDA (see Figure 10-16):

1. Connect the **15-pin D-type** connector, at one end of the CAT 5 cable, to the SPR's 15-pin D-type port labeled **DATA POWER SYNC**.
2. Connect the **15-pin D-type** connector, at the other end of the CAT 5 cable, to the SDA's **15-pin D-type** port.

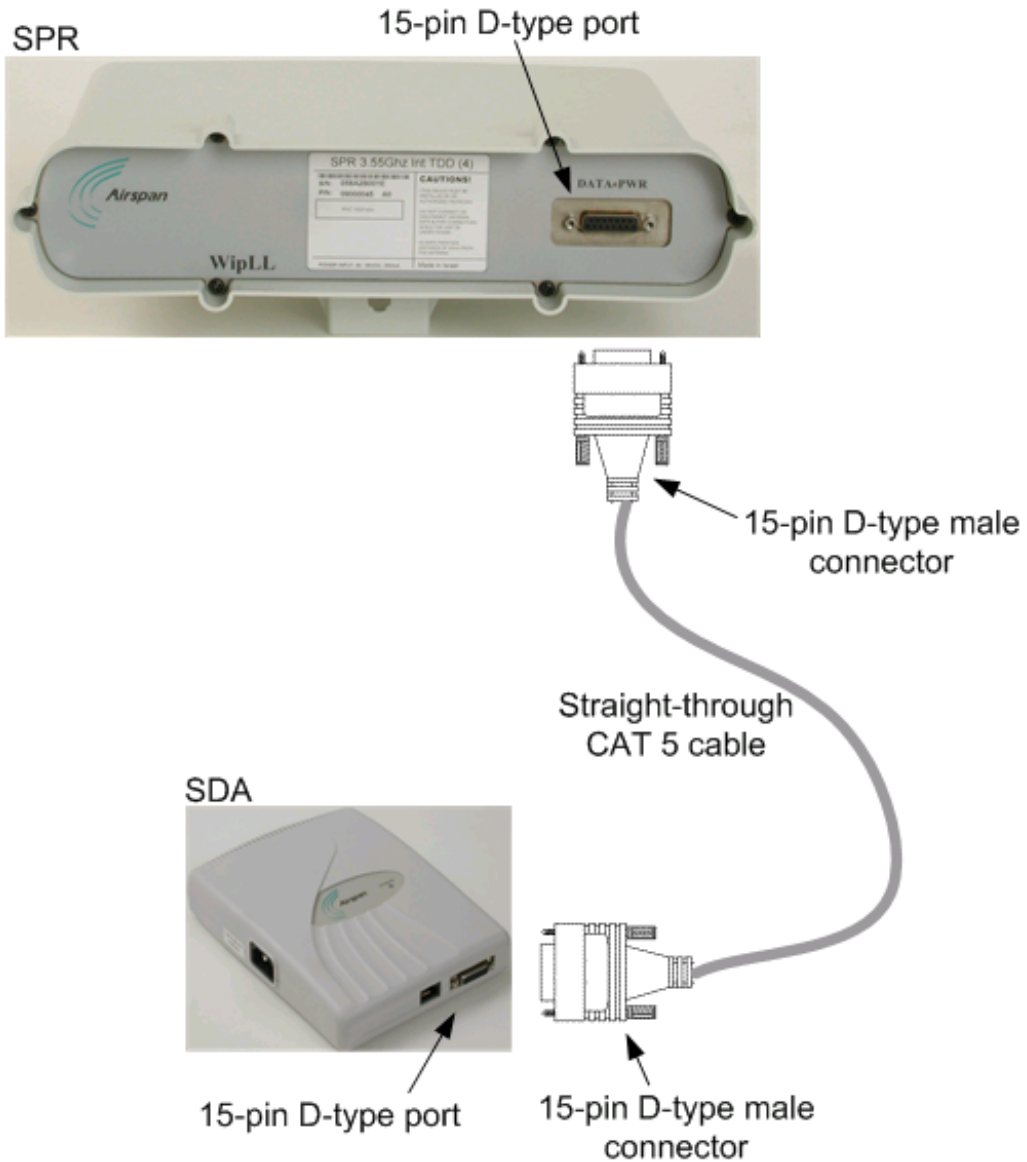

Figure 10-16: SPR-to-SDA cable connections



Note: The maximum cable length permissible between the SPR and SDA is 100 meters.

10.5. Connecting to a PC for Serial Configuration

To configure an SPR, you need to connect a PC running the WipLL WipConfig configuration tool to the SPR. The SPR's 15-pin D-type port also provides serial interface to a PC for SPR initial configuration. This port uses 9 of its 15 pins for serial interface; the remaining pins are used for interfacing with the SDA with which the SPR remains connected. To connect the SPR to the management station (i.e., PC) and the SDA, a Y-cable (splitter) is used.



Note: SPR configuration is performed while the SPR is connected to the SDA.

The SPR-to-PC and SDA cable connections for SPR serial configuration are as follows:

- **Connectors:**
 - **SPR side:** 15-pin D-type male (only 9-pins used)
 - **PC side:** 9-pin D-type (RS-232)
 - **SDA side:** 15-pin D-type male
- **Cable:** straight-through Y-cable

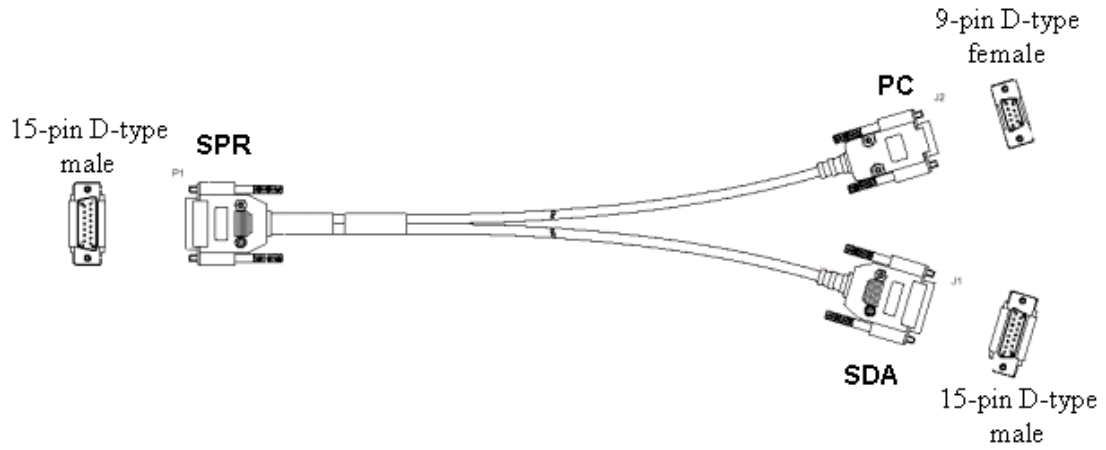

Figure 10-17: Y-cable for serial connection

■ Connector pinouts:

Table 10-5: Y-cable SPR-to-SDA connector pinouts

SPR			SDA		
15-pin D-type male	Pin	Function	Pin	Function	15-pin D-type male
	1	0 VDC	1	+48 VDC	
	2	+48 VDC	2	-48 VDC	
	3	Ethernet Tx+	3	Rx+	
	4	Ethernet Tx-	4	Rx-	
	5	Ethernet Rx+	5	Tx+	
	6	Ethernet Rx-	6	Tx-	
	7	Hop Sync+	7	Sync.+	
	8	Hop Sync-	8	Sync.-	

Table 10-6: Y-cable SPR-to-PC connector pinouts

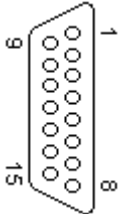
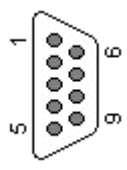
SPR			PC		
15-pin D-type male	Pin	Function	Pin	Function	9-pin D-type female
	12	GND	5	GND	
	14	RS232 Rx	3	Rx	
	15	RS232 Tx	2	Tx	

The Y-cable connector pin assignments are displayed schematically in Figure 10-18.

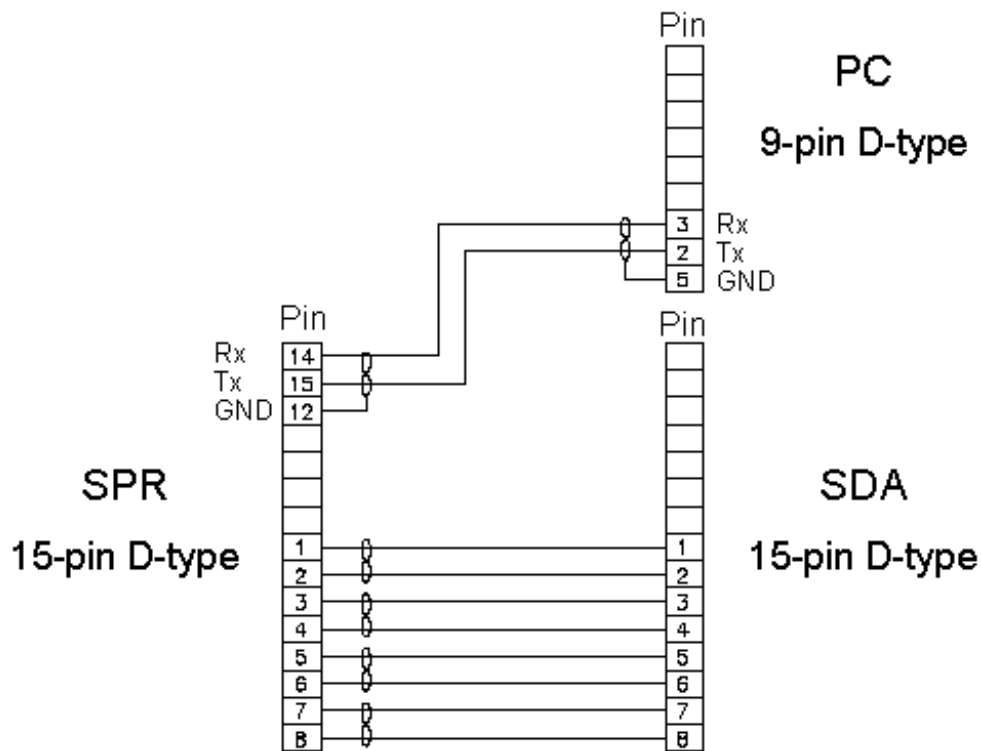

Figure 10-18: Y-cable connector pin assignment

To connect the SPR to a PC for serial configuration (see Figure 10-19):

1. Connect the **15-pin D-type male** connector, at the one end of the Y-cable, to the SPR.
2. Connect the **15-pin D-type male** connector, at the other end of the Y-cable, to the SDA.
3. Connect the **9-pin D-type female (RS232)** connector, at the other end of the Y-cable, to the PC's serial port.

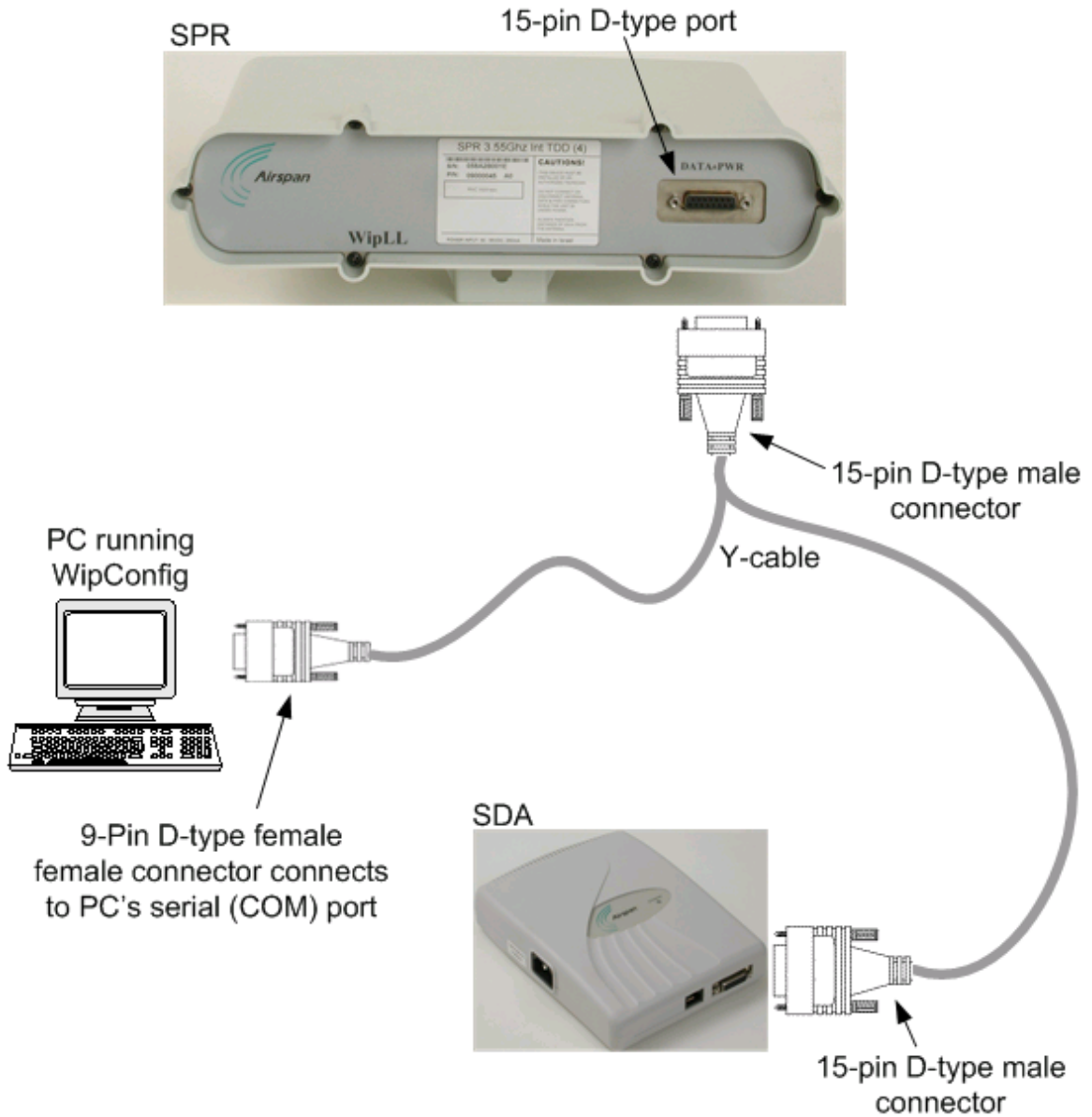

Figure 10-19: SPR cable connections for serial configuration



Note: For performing SPR initial configuration using WipLL's management applications, refer to Airspan's *WipConfig User's Guide* or *WipConfig PDA User's Guide*.

10.6. Connecting Power

The SPR receives power through its 15-pin D-type port from the SDA. In turn, the SDA connects to an external AC-DC power adapter from where it receives power. The SDA provides 48 VDC nominal power to the SPR (minimum of 30 VDC; maximum of 55 VDC).



Warning: If you are using an external antenna, ensure that you connect the antenna before connecting the SPR to the power source.



Note: For a description on connecting power to the SPR and SDA, see Chapter 9, "Installing the SDA".
