



## Installing the IDR

This chapter describes the installation of the WipLL **Indoor Data Radio (IDR)**, which is installed at the base station.

This chapter includes the following sections:

- Overview
- Physical Dimensions and Basic Design
- Mounting the IDR
  - Desk Mounting
  - Wall and Pole Mounting
- Connecting a Third-Party External Antenna
- Connecting to an Ethernet Network
- Positioning IDR for Optimum RF Reception
- Connecting to PC for Serial Configuration
- Connecting Power
  - Power LEDs



---

**Warning:** When operating in the 900 MHz band, the IDR model with an external antenna must not be co-located or operating in conjunction with any other antenna or transmitter.

---

## 10.1. Overview

The IDR device is an optional WipLL device that combines the functionality of the SPR and SDA devices. The IDR has a built-in antenna that provides an interface for transmission with the base station. In addition, the IDR provides an interface for 10Base-T Ethernet with the subscriber's network. However, unlike the SDA, a separate power supply unit (power adapter) powers the IDR.

The IDR is available in two models:

- IDR with an internal antenna
- IDR with a TNC connector for connecting to a third-party external antenna

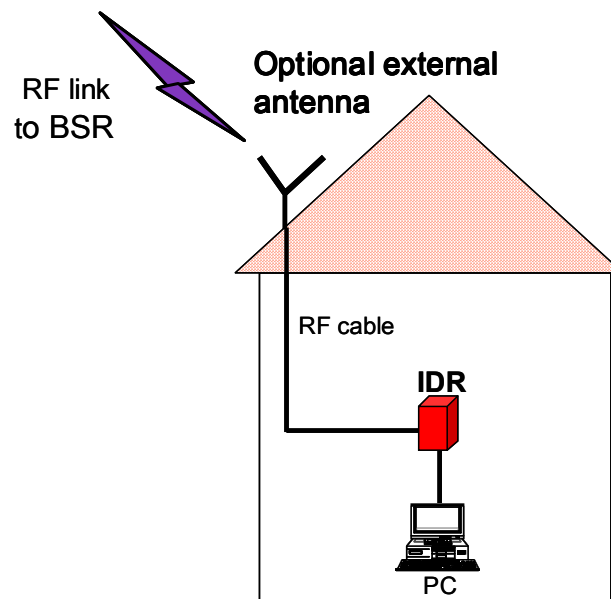


Figure 10-1: Typical IDR setup at subscriber's premises (showing optional antenna)



---

---

**Warning:** To avoid electrical or fire hazard, ensure that all connections to the IDR are performed prior to connecting the power supply.

---

---



---

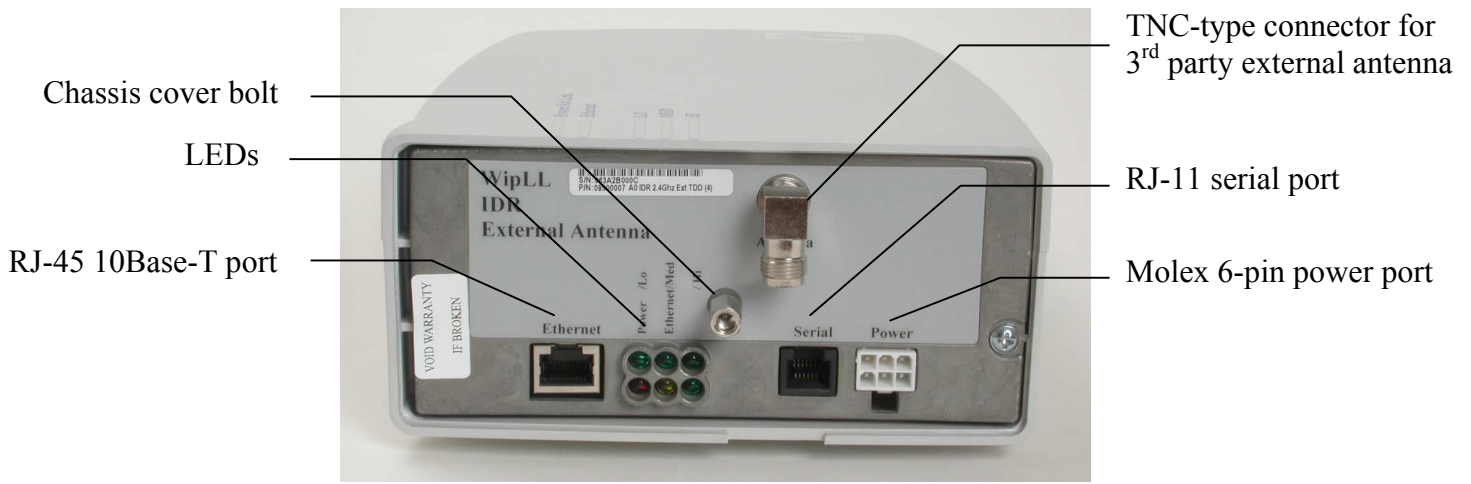
---

**Note:** The digital portion of the transceiver has been tested and found to comply with the limits for a Class B digital device, pursuant to part 15 of the FCC rules. These limits are designed to provide reasonable protection against harmful interference in a residential installation. This equipment generates, uses, and can radiate radio frequency energy and, if not installed and used in accordance with the instructions, may cause harmful interference to radio communications. However, there is no guarantee that interference will not occur in a particular installation. If this equipment does cause harmful interference to radio or television reception, which can be determined by turning the equipment on and off, the user is encouraged to try correct the interference by performing one or more of the following measures:

- Reorientate or relocate the receiving antenna
  - Increase separation between the equipment and receiver
  - Connect the equipment to an outlet on a circuit different from that to which the receiver is connected
  - Consult the dealer or an experienced radio/TV technician for help
- 
-

## 10.2. Physical Dimensions and Basic Design

The IDR is encased in a chassis providing access to the IDR's communication port at the front panel.



**Figure 10-2: IDR front panel with cover removed exposing ports**

The IDR's physical dimensions are described in Table 10-1.

**Table 10-1: IDR physical dimensions**

Parameter	Value	Comment
Weight	1,43 kg	
Dimensions (H x W x D)		Note: Dimensions exclude the external power adapter.
<ul style="list-style-type: none"> <li>IDR with built-in antenna</li> </ul>	<ul style="list-style-type: none"> <li>155 mm (6.1 inches) x 233 mm (9.17 inches) x 74.5 mm (2.93 inches)</li> </ul>	
<ul style="list-style-type: none"> <li>IDR with an external antenna</li> </ul>	<ul style="list-style-type: none"> <li>120.5 mm (4.74 inches) x 61mm (2.4 inches) x 35 mm (1.37 inches)</li> </ul>	

## 10.3. Mounting the IDR

The IDR may be mounted in the following ways:

- Desk
- Pole
- Wall



---

---

**Note:** Before mounting or attaching any brackets to the IDR, ensure that all cables are securely attached and that the unit functions correctly in the proposed location.

---

---

### 10.3.1. Desk Mounting

The IDR may be mounted on a desk in one of the following ways:

- Vertically
- Horizontally

### 10.3.1.1. Vertical-Desk Mounting

A base plate is provided to mount the unit vertically on the desk, i.e., in standing position. The base plate is designed to fit in one position only.

**To desk mount the IDR in a vertical position:**

- Insert the IDR into the base and press firmly until the tabs click into place. See Figure 10-3.

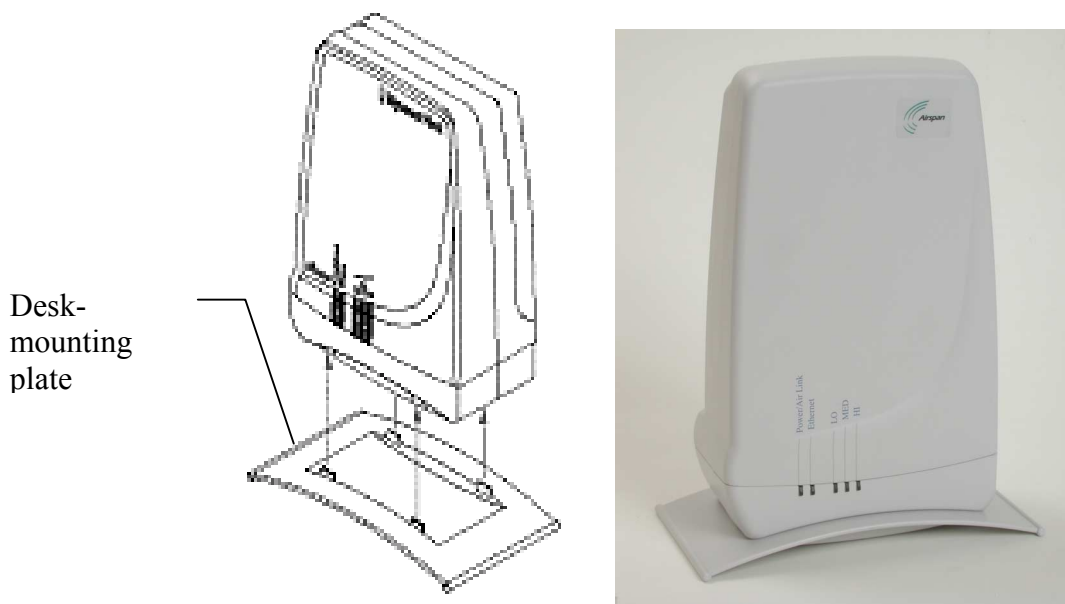


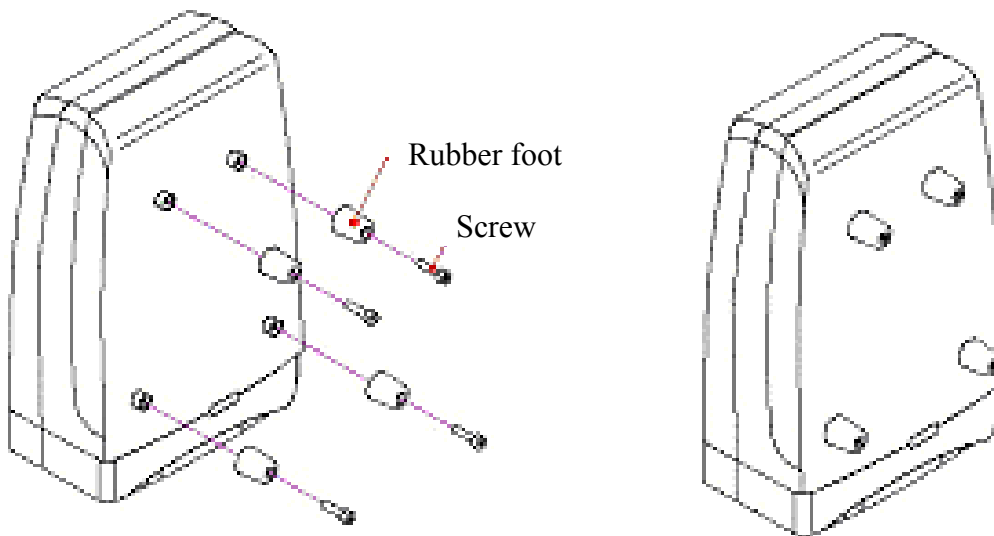
Figure 10-3: IDR vertical desk mounting

### 10.3.1.2. Horizontal-Desk Mounting

To position the IDR horizontally on the desk, four rubber pads, supplied with the unit, must be fitted to avoid damage to mounting surfaces.

**To desk mount the IDR in a horizontal position:**

- Secure the rubber pads to the posts provided on the rear of the IDR using four self-tapping screws. See Figure 10-4.



**Figure 10-4: IDR horizontal desk mounting using supplied rubber pads and tapping screws**

## 10.3.2. Wall and Pole Mounting

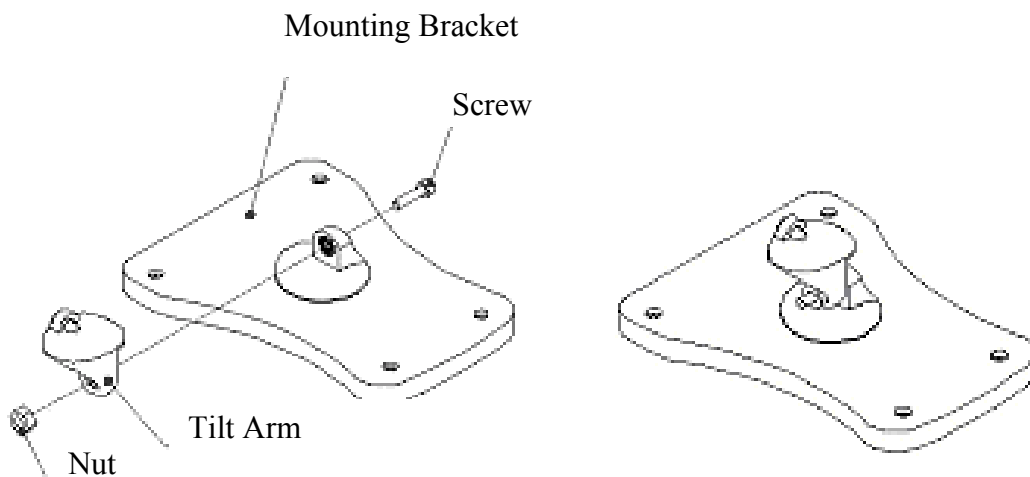
The IDR may be mounted to a wall or to a 5-cm diameter pole. Wall and pole mounting both use the same mounting brackets and wall hanger plate.

### 10.3.2.1. Assembling the Bracket and Hanger Plate

The wall hanger plate secures the IDR to a wall or pole. The wall bracket and hanger plate allows positioning the IDR in the correct orientation. Holes are provided in the wall hanger plate for both pole and wall mounting options

**To assemble the bracket and hanger plate:**

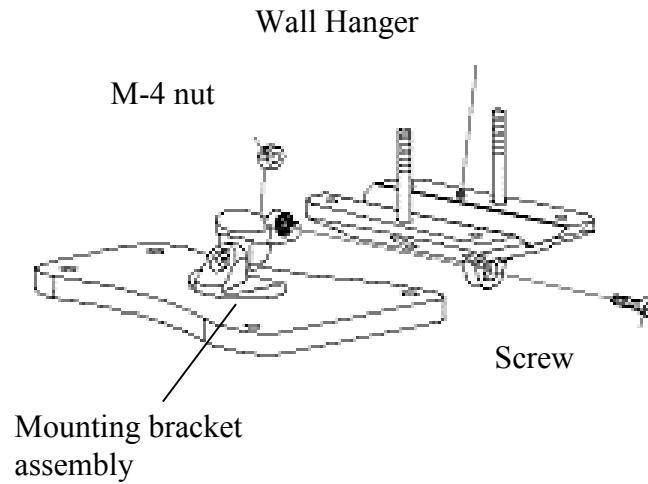
1. Insert a 4 mm hex nut into the slot on the tilt arm component
2. Holding the nut in place, attach the tilt arm to the mounting bracket using a 4 mm socket head bolt. Hand tighten the bolt only. See Figure 10-5.
3. Affix the complete mounting assembly to the rear of the IDR using the 4-off self-tapping screws supplied with the kit.



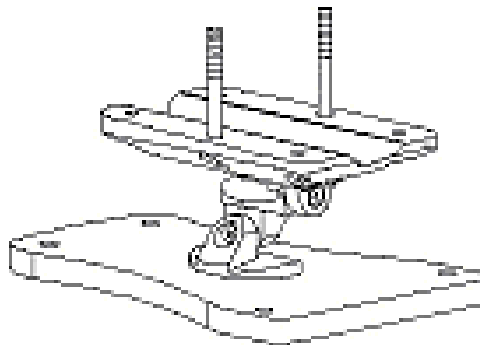
**Figure 10-5: Mounting bracket assembly**



4. Attach the wall bracket assembly to wall hanger using an M4 socket-head bolt and nut as shown in Figure 10-6. The bolt is only to be hand tightened at this stage.

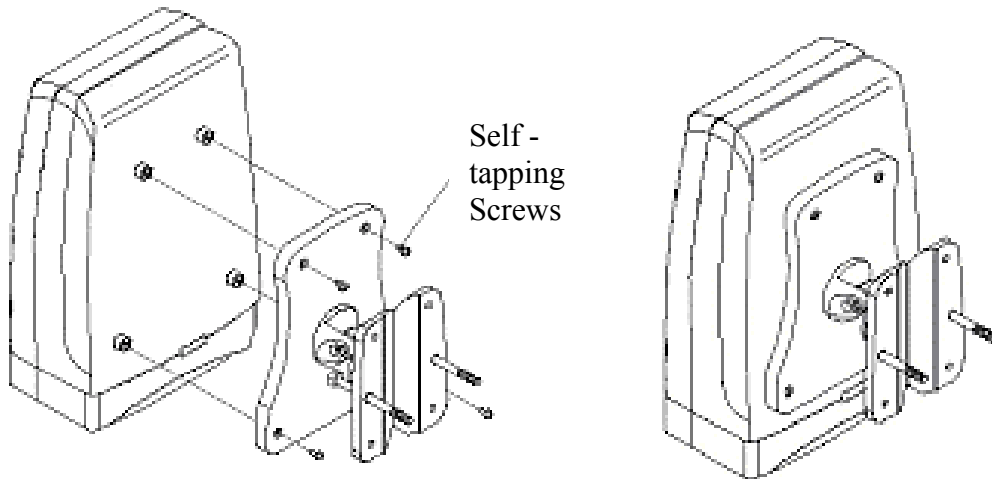


**Figure 10-6: Wall hanger fixing method**



**Figure 10-7: Wall hanger & mounting bracket assembly**

5. Once assembled, the IDR mounting bracket assembly may be secured to the rear of the IDR using the 4-off self-tapping screws supplied in the unit fixing kit. See Figure 10-8.



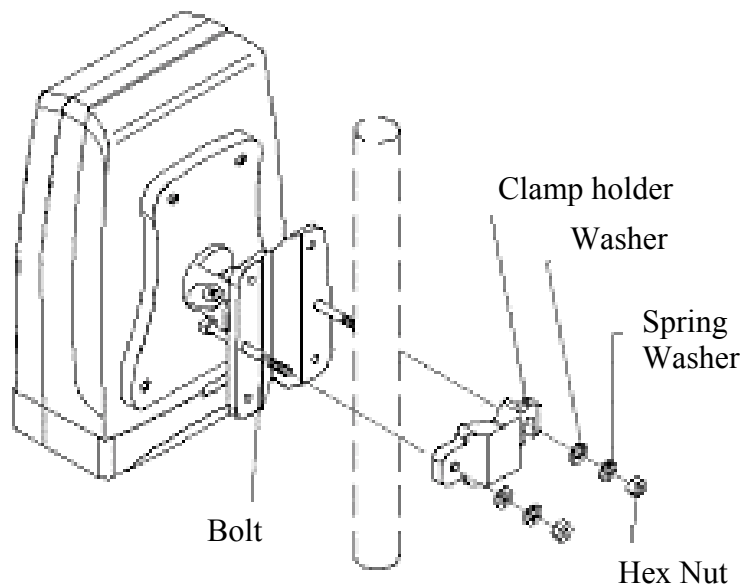
**Figure 10-8: Mounting bracket assembly secured to IDR**

### 10.3.2.2. Pole Mounting

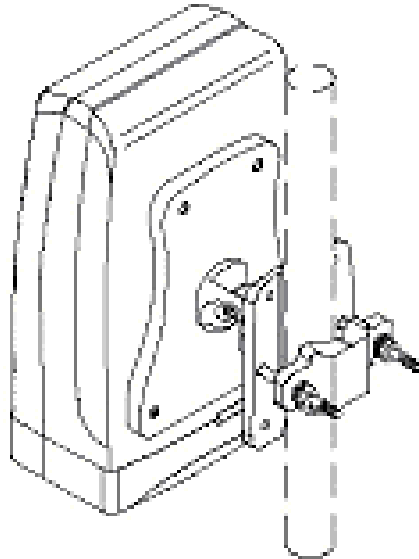
Prior to mounting the IDR to a pole the wall mounting bracket assembly must be fitted as described in the previous section.

**To pole mount the IDR:**

1. Offer up the IDR assembly to the pole as shown in Figure 10-9.
2. Insert 2-off M10 bolts through the holes in the wall hanger.
3. Slide the clamp-holder into position and secure using washers, spring-washers and nuts as illustrated in Figure 10-10. Finger-tighten the fasteners.
4. Slide the IDR to the required location on the pole and fully tighten the fasteners.



**Figure 10-9: IDR pole mounting components**



**Figure 10-10: IDR secured to a pole**

**To set the correct IDR inclination:**

1. Loosen the 2-off M4 socket head screws on the mounting bracket tilt-arm
2. Position the IDR at the desired angle.
3. Re-tighten the 2 off socket screws on the tilt arm.

### 10.3.2.3. Wall Mounting



**Warning:** Prior to drilling holes in a wall ensure that there are no hidden services such as electricity cables or water pipes. A stop must be used on the power drill to ensure that bored holes do not exceed 35 mm.

**To mount the IDR on a wall:**

1. Loosen the 2-off M4 socket head screws on the mounting bracket tilt-arm and remove the wall hanger.
2. Offer up the wall hanger to the wall and scribe through the mounting hole locations.
3. Drill holes to suit the type of wall fixing.
4. If required insert anchor plugs suited to the wall material.
5. Affix the wall hanger using 4-off screws suited to the anchor plugs and wall material.
6. Re-attach the IDR mounting bracket to the wall hanger. Finger tighten the screws.
7. Position the IDR at the desired inclination.
8. Re-tighten the screws to lock the IDR in position.

## 10.4. Connecting a Third-Party External Antenna

The IDR provides a TNC-type connector for connecting a third-party antenna to the IDR. This antenna can be placed on the subscriber's windowsill to provide better RF signal reception with the BSR.

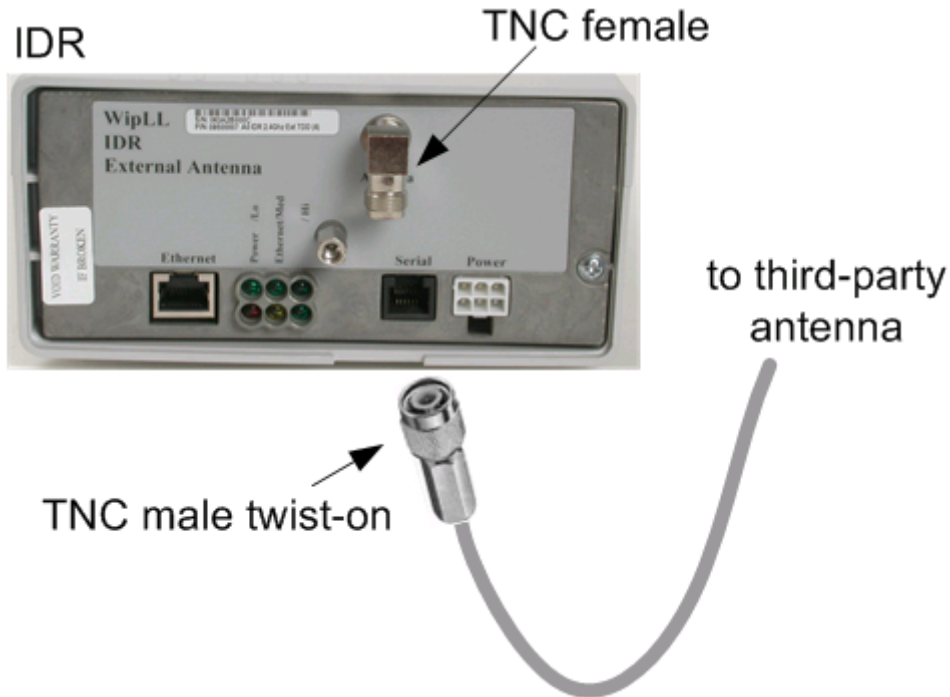


**Note:** Airspan supplies unterminated cables for N-type connectors. Therefore, refer to the cable crimping procedures for N-type connectors detailed in Appendix B, "Cable Crimping".

- **Connector:** TNC-type male



**Warning:** Before connecting the external antenna, ensure that the IDR is NOT connected to the power source.



**Figure 10-11: Connecting a third-party antenna**



**Warnings:**

- 1) It is the responsibility of the person installing the WipLL system to ensure that when using the outdoor antenna kits in the United States (or where FCC rules apply), that only those antennas certified with the product are used. The use of any antenna other than those certified with the product is expressly forbidden in accordance with FCC rules CFR47 part 15.204. The installer should configure the output power level of antennas according to country regulations and per antenna type.
- 2) Indoor units and antennas should be installed **ONLY** by experienced installation professionals who are familiar with the local building and safety codes and are licensed by the appropriate government authorities.

## 10.5. Connecting to an Ethernet Network

The IDR provides one Ethernet interface for the subscriber's Ethernet network. This port is located on the front panel, and labeled **Ethernet**.

■ **Connector:** 8-Pin RJ-45

■ **Cable:** CAT-5

■ **Connector pinouts:**

Pin	Function
1	Rx+
2	Rx-
3	Tx+
4	Not Connected
5	Not Connected
6	Tx-
7	Not connected
8	Not connected

**To connect IDR to the subscriber's Ethernet network:**

1. Attach the 8-pin RJ-45 connector, at one end of the cable, to the IDR's Ethernet port, labeled **Ethernet** (see Figure 10-12).
2. Attach the 8-pin RJ-45 connector, at the other end of the cable, to the PC's LAN port (see Figure 10-12).



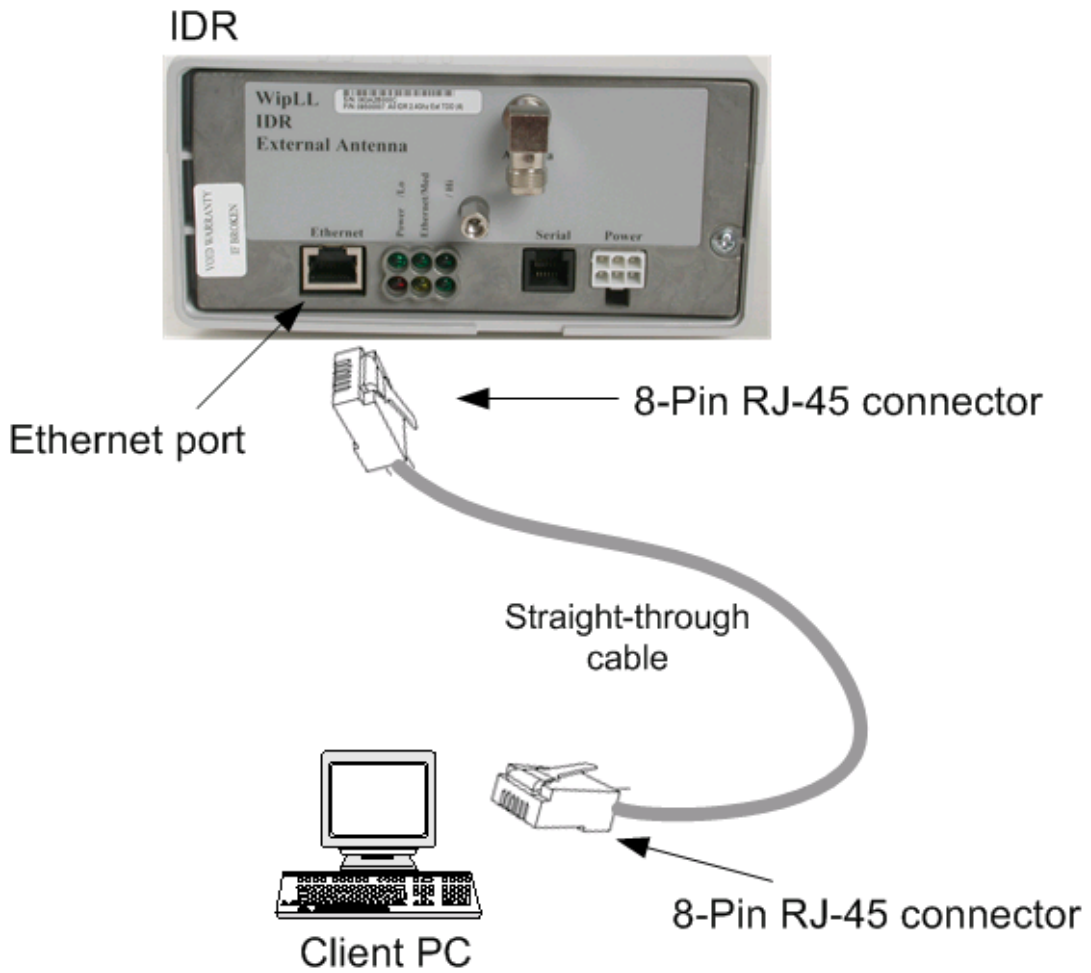


Figure 10-12: Connecting IDR to a client PC

## 10.5.1. Ethernet LED Indicator

The IDR provides one LED that indicates an Ethernet connection. This LED is labeled **Ethernet** and is located on the IDR's top panel.

**Table 10-2: Description of Ethernet LEDs**

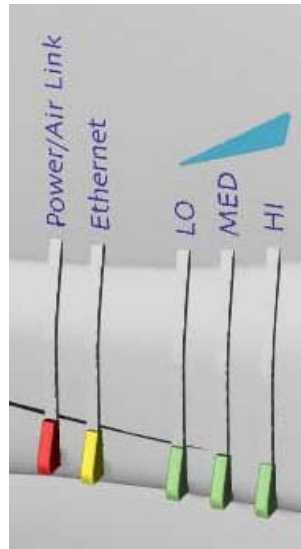
LED	Color	Status	Indicates
Ethernet	Orange	On	Physical link between IDR and Ethernet network
		Off	No physical link between IDR and Ethernet network
		Blinking	Data is flowing through the Ethernet port

## 10.6. Positioning IDR for Optimum RF Reception

Once mounted to a wall, pole, or desk the IDR unit may be positioned to ensure the best RF signal communication with the BSR. The RF signal strength is indicated by three LEDs on the IDR chassis. The following table describes the RF signaling strength indicator LEDs.

**Table 10-3: Description of RF signal strength LEDs**

LED	Color	Function	Status	Description	
				Previous Releases	Release 4.2B
RSSI LEDs: <b>LO</b> , <b>MED</b> , and <b>HI</b>	Green	RSSI level	All LEDs On	$\text{RSSI} \geq -60 \text{ dBm}$	$\text{RSSI} \geq -60 \text{ dBm}$
			Two LEDs On	$-65 \text{ dBm} \leq \text{RSSI} \leq -61 \text{ dBm}$	$-70 \text{ dBm} \leq \text{RSSI} < -60 \text{ dBm}$
			One LED On	$-70 \text{ dBm} \leq \text{RSSI} \leq -66 \text{ dBm}$	$-80 \text{ dBm} \leq \text{RSSI} < -70 \text{ dBm}$
			One LED Blinking	$\text{RSSI} \leq -77 \text{ dBm}$	$-90 \text{ dBm} \leq \text{RSSI} < -80 \text{ dBm}$
			All LEDs Off	$-76 \text{ dBm} \leq \text{RSSI} \leq -71 \text{ dBm}$	$\text{RSSI} < -90 \text{ dBm}$



**Figure 10-13: IDR LED indicators**

**To position the IDR for optimum RF signal:**

- Position the IDR until all three RF signaling strength indicator LEDs are lit.

Refer to Section 10.3.2, “Wall and Pole Mounting” page 10-8 for details on adjusting IDR wall and pole mounting position.

For desk-top mounting, the IDR can be simply relocated to obtain the strongest signal.

## 10.7. Connecting to PC for Serial Configuration

To perform IDR initial configuration, you need to connect the IDR's RJ-11 port to the serial port of a PC running the WipLL network management application (i.e., WipConfig).

The IDR's RJ-11 port labeled **Serial**, located on the front panel, connects to the serial port of a PC via a cable with an RJ-11 connector on the one end, and a 9-Pin D-type connector on the other (i.e., a direct serial cable connection-DCC).

### ■ Connectors:

- 6-Pin RJ-11 male to 9-pin D-type female adapter
- 9-Pin D-type male to 9-Pin D-type female adapter

### ■ Cable:

- **Straight-through cable** with 6-Pin RJ-11 male on one end and 9-Pin D-type female on the other (connects between IDR and crossover cable)
- **Crossover cable** with 9-Pin D-type male on one end and 9-Pin D-type female on the other (connects straight-through cable to PC)

■ Connector pinouts:

Straight-through cable		Crossover cable		
6-Pin RJ-11		9-Pin D-type female	9-Pin D-type male	9-Pin D-type male
Pin	Function	Pin	Pin	Pin
1	Rx	2	4	3
2	Not connected	-	-	-
3	NC	-	-	-
4	NC	-	-	-
5	GND	5	1	5
6	Tx	3	3	2
		-	-	-
		-	-	-
		-	-	-

**To connect the IDR to the WipLL management station (PC):**

1. Connect the **6-Pin RJ-11** connector to the IDR's RJ-11 port (labeled **Serial**) located on the IDR's front panel (see Figure 10-14).
2. Connect the **9-Pin D-type female** connector, at the other end of the straight-through cable, to the **9-Pin D-type male** connector of the cross-over cable (see Figure 10-14).
3. Connect the **9-Pin D-type male** connector, at the other end of the cross-over cable, to the PC's serial port (see Figure 10-14).

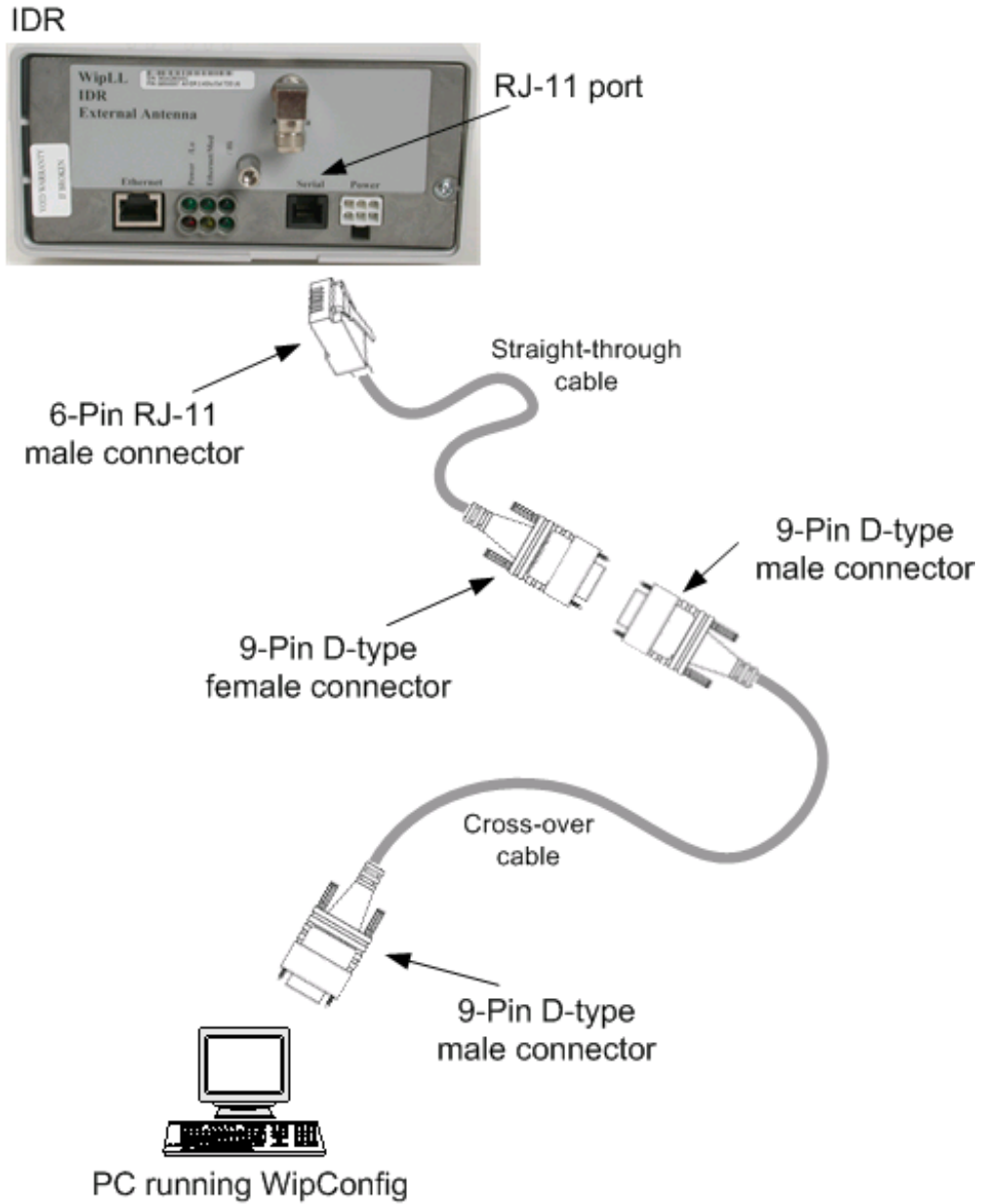


Figure 10-14: IDR-to-PC Serial Cable Connections

## 10.8. Connecting Power

The IDR is powered by an external power supply (*Triple Output External Adapter*). The IDR connects to the power adapter via the IDR's power port located on the IDR's front panel.

The following table lists the external power supply specifications:

**Table 10-4: IDR power supply requirements**

Power parameter	Units
Voltages	110-240 VAC
Frequency	50 to 60Hz
Maximum power consumption	Less than 15W



**Warning:** If you are using an external antenna, ensure that you connect the antenna before connecting the BSR to the power source.



**Warning:** Ensure that plugs fitted to mains power leads for subscriber premises equipment are compatible with AC mains sockets. Do not replace plugs on power leads to suit local requirements without first verifying earthing practice for the country and equipment in question.

Careful consideration must be given to issues including local wiring requirements, cable color-coding, and safety earthing and circuit protection requirements.



**Warning:** To avoid electrical or fire hazard, ensure that the data connections to the IDR are made prior to connecting the power supply. The AC mains must be capable of supplying at least 230 VAC

Prior to connecting to the power outlet, the following pre-connection inspection should be performed on power sockets:

- Power socket shall be visually inspected to ensure that no other equipment is connected to the power outlet.

- There is no physical sign of damage to the power outlet.
- There should not be any visible sign of water or dampness on or around the power outlet.
- The plug and socket assemblies are to be firmly secured.
- The power outlet shall be checked using a proprietary plug tester such as a 'Martindale Ze' type. Checks are required to verify the earth loop impedance value and the presence of phase, neutral and earth connections.
- **Connector:** 6-Pin power connector
- **Cable:** 3-core 0.7mm<sup>2</sup> type
- **Connector pinouts:**

Pin	Function
1	+6.5V
2	+5V
3	3.3V
4	GND
5	Not connected
6	Not connected

**To connect the power:**

1. Plug the AC power adapter's **6-pin Molex** connector into the IDR's power port labeled **Power** (see Figure 10-15).
2. Plug the **AC power plug female**, at the one end of the AC power cable, into the AC power adapter's socket (see Figure 10-15).
3. Plug the **AC power plug male**, at the other end of the AC power cable, into the electrical outlet (see Figure 10-15).



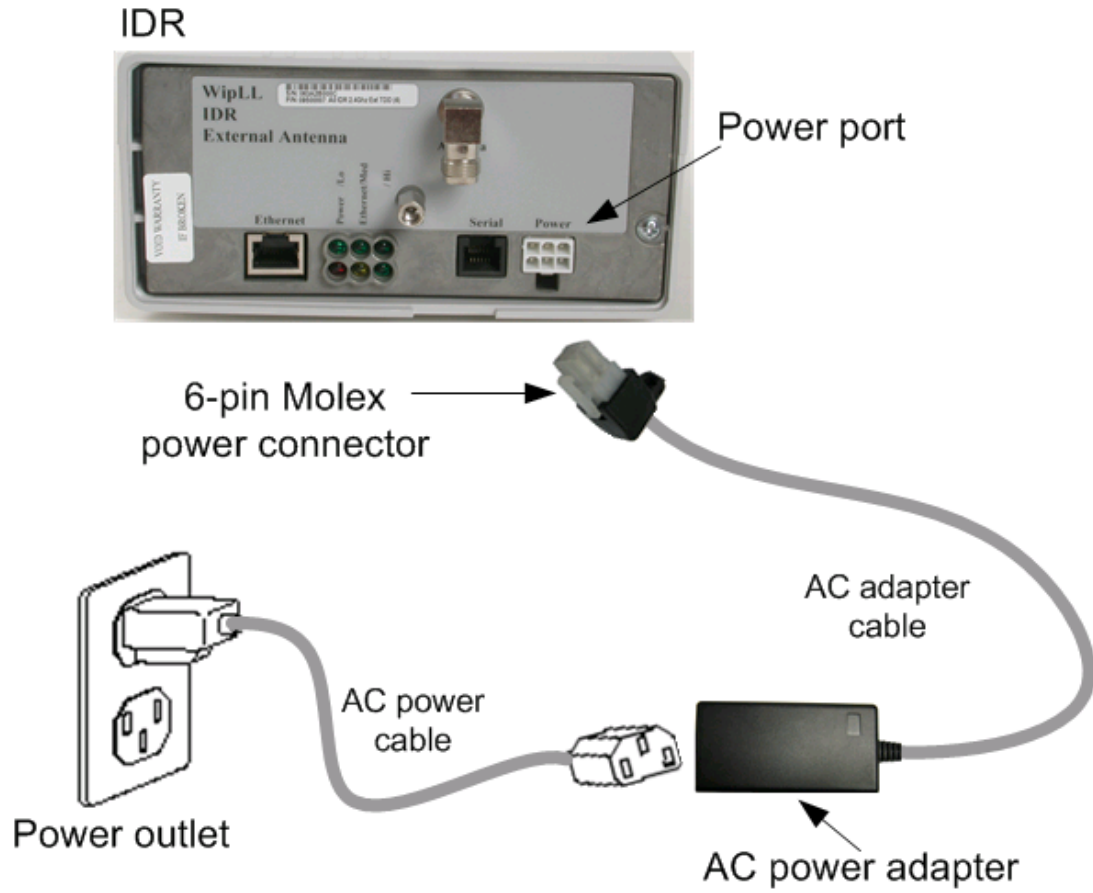


Figure 10-15: Connecting power to the IDR

## 10.8.1. Power LEDs

The IDA provides a power LED indicator, labeled **Power**, which indicates whether a power supply exists. The **Power** LED is located on the front panel of the IDR chassis.

**Table 10-5: Description of Power LEDs**

LED	Color	Status	Meaning
Power	Red	On	The SDA receives power supply
		Off	No power received