



IP-based
Broadband Wireless Access (BWA) System

605-0000-707 Rev C

ProST 4.9

Hardware Installation Guide

Table Of Contents

Warnings and Notices	2
Radio Interference	2
Avoiding Radio Interference.....	2
Modifications	2
General	2
Manufacturer's Disclaimer Statement	2
Declaration of Conformity	3
European Community, Switzerland, Norway, Iceland, and Liechtenstein	3
Declaration of Conformity with Regard to the R&TTE Directive 1999/5/EC.....	3
Preface.....	5
Purpose	5
Targeted Audience	5
Referenced Documentation.....	5
Conventions	5
System Overview.....	6
Main Features.....	6
Customer Benefits.....	6
Architecture	7
ProST Models.....	7
ProST Block Diagram	8
ProST Protocols Stack	8
Theory of Operation	9
Getting Started.....	10
Package Contents.....	10
Minimum PC Requirements	10
Required Tools.....	10
Radio Site Planning	11
Minimal Radio Path Obstructions.....	11
Fresnel Zone Clearance	11
Multipath Fading	12
Radio Antenna Alignment	12
Physical Description	13
ProST	13
Physical Dimensions	13
Port.....	13
SDA-1 Physical Description.....	14
Physical Dimensions	14
Ports	14
LED.....	14
SDA-4S Type II and SDA-4S/VL Type II (Optional).....	14
Physical Dimensions	15

Ports	15
LEDs	16
Mounting	17
Wall Mounting.....	17
Pole Mounting.....	20
SDA-4S	23
Desktop Mounting	23
Wall Mounting.....	24
Cabling The ProST.....	26
Connecting ProST to SDA-1	27
Connecting ProST to SDA-4S	29
Connecting ProST to a Computer.....	31
Using SDA-1 Type II	31
Using the SDA-4S Type II or SDA-4S/VL Type II	32
Connecting Power	35
DC Power Source	35
AC Power Source.....	35
Using SDA-1 Type II	35
Plugging the SDA-1 into an Electrical Wall Outlet	36
Using SDA-4S Type II and SDA-4S/VL Type II	37
Connecting the Lightning and Surge Protector	38
To install the protector:.....	38
Specifications	41
ProST Specifications	41
SDA-1 Type II Specifications.....	43
SDA-4S Type II and SDA-4S/VL Type II Specifications.....	43
Lightning/Surge Protector Specifications	44
General	46
Contact Information	46
Copyright Information	47
Glossary	48
Index	51



605-0000-707
ProST 4.9 Installation Guide

WARNINGS AND NOTICES

Radio Interference

This equipment generates, uses, and can radiate radio frequency energy and, if not installed and used in accordance with the instructions, may cause harmful interference to radio communications. However, there is no guarantee that interference will not occur in a particular installation. If this equipment does cause harmful interference to radio or television reception, which can be determined by turning the equipment on and off, the user is encouraged to try correct the interference by performing one or more of the following measures:

- ❑ Reorientate or relocate the receiving antenna
- ❑ Increase separation between the equipment and receiver
- ❑ Connect the equipment to an outlet on a circuit different from that to which the receiver is connected
- ❑ Consult the dealer or an experienced radio/TV technician for help

Avoiding Radio Interference

- ❑ This transmitter must not be co-located or operating in conjunction with any antenna or transmitter.
- ❑ Ensure a minimum of 1-meter separation between co-located ProST's.

Modifications

Any changes and modifications to this device that are not expressly approved by Airspan Networks may void the user's authority to operate the equipment.

General

- ❑ Only qualified personnel should be allowed to install, replace, and service the equipment.
- ❑ The device cannot be sold retail, to the general public or by mail order. It must be sold to dealers.
- ❑ Installation must be controlled.
- ❑ Installation must be performed by licensed professionals.
- ❑ Installation requires special training.
- ❑ The ProST radio and antenna should be installed ONLY by experienced installation professionals who are familiar with local building and safety codes and, wherever applicable, are licensed by the appropriate government regulatory authorities. Failure to do so may void Airspan's AS.MAX product warranty and may expose the end user or the service provider to legal and financial liabilities. Airspan and its resellers or distributors are not liable for injury, damage or violation of regulations associated with the installation of outdoor units or antennas.

Manufacturer's Disclaimer Statement

The information in this document is subject to change without notice and does not represent a commitment on the part of the vendor. No warranty or representation, either expressed or implied, is made with respect to the quality, accuracy or fitness for any particular purpose of this document. The manufacturer reserves the right to make changes to the content of this document and/or the products associated with it at any time without obligation to notify any person or organization of such changes. In no event will the manufacturer be liable for direct, indirect, special, incidental or consequential damages arising out of the use or inability to use this product or documentation, even if advised of the possibility of such damages. This document contains materials protected by copyright. All rights are reserved. No part of this manual may be reproduced or transmitted in any form, by any means or for any purpose without expressed written consent of its authors. Product names appearing in this document are mentioned for identification purchases only. All trademarks, product names or brand names appearing in this document are registered property of their respective owners.

DECLARATION OF CONFORMITY

European Community, Switzerland, Norway, Iceland, and Liechtenstein

Declaration of Conformity with Regard to the R&TTE Directive 1999/5/EC

English:

This equipment is in compliance with the essential requirements and other relevant provisions of Directive 1999/5/EC.

Deutsch:

Dieses Gerät entspricht den grundlegenden Anforderungen und den weiteren entsprechedenen Vorgaben der Richtlinie 1999/5/EU.

Dansk:

Dette udstyr er i overensstemmelse med de væsentlige krav og andre relevante bestemmelser i Directiv 1999/5/EF.

Español:

Este equipo cumple con los requisitos esenciales asi como con otras disposiciones de la Directive 1999/5/EC.

Greek:

ΜΕ ΤΗΝ ΠΑΡΟΥΣΑ Airspan ΔΗΛΩΝΕΙ ΟΤΙ Ο ΕΞΟΠΛΙΣΜΟΣ ΣΥΜΜΟΡΦΩΝΕΤΑΙ ΠΡΟΣ ΤΙΣ ΟΥΣΙΩΔΕΙΣ ΑΠΑΙΤΗΣΕΙΣ ΚΑΙ ΤΙΣ ΛΟΙΠΕΣ ΣΧΕΤΙΚΕΣ ΔΙΑΤΑΞΕΙΣ ΤΗΣ ΟΔΗΓΙΑΣ 1999/5/ΕΚ.

Français:

Cet appareil est conforme aux exigences essentielles et aux autres dispositions pertinentes de la Directive 1999/5/EC.

Íslenska:

Þessi búnaður samrýmist lögboðnum kröfum og öðrum ákvæðum tilskipunar 1999/5/ESB.

Italiano:

Questo apparato é conforme ai requisiti essenziali ed agli altri principi sanciti dalla Direttiva 1999/5/EC.

Nederlands:

Deze apparatuur voldoet aan de belangrijkste eisen en andere voorzieningen van richtlijn 1999/5/EC.

Norsk:

Dette utstyret er i samsvar med de grunnleggende krav og andre relevante bestemmelser i EU-directiv 1999/5/EC.

Português:

Este equipamento satisfaz os requisitos essenciais e outras provisões da Directiva 1999/5/EC.

Suomalainen:

Tämä laite täyttää direktiivin 1999/5/EY oleelliset vaatimukset ja on siinä asetettujen muidenkin ehtojen mukainen.

Svenska:

Denna utrustning är i överensstämmelse med de väsentliga kraven och andra relevanta bestämmelser i Direktiv 1999/5/EC.

The Declaration of Conformity related to this product can be obtained from product_management@Airspan.com

PREFACE

Thank you for purchasing Airspan's ProST wireless access device. The ProST customer premise equipment (CPE) is part of Airspan's AS.MAX family of WiMAX-based products.

This section discusses the purpose, audience, conventions, and customer support of this guide.

Purpose

This guide provides step-by-step instructions for setting up and installing the ProST.

Targeted Audience

This guide is intended for the Airspan technician who is a qualified installer responsible for installing the ProST.



Referenced Documentation

For a description of the Web-based management tools for configuring and managing ProST, see the following manuals:

- *WiMAX Web-based Management User's Guide*

Conventions

This guide uses the following typographical conventions:

Convention	Meaning	Example
Bold	Command, icon, button, and field	Click the Next button.
"To" in bold face and at the beginning of a sentence	Introduces a numbered procedure	To download a SW file: 1. ...
	Note that provides useful information	--
	Warning that provides information that can prevent and avoid bodily or mechanical harm	--

SYSTEM OVERVIEW

The ProST is an outdoor WiMAX-based customer premises equipment (CPE). The ProST, which uses Intel Corporation's Pro/Wireless 5116 broadband interface, connects IP-enabled devices directly to WiMAX networks. Designed for the residential and small enterprise (SME) markets, the device supports high-speed broadband Internet through a Fast Ethernet connection. The ProST ensures high service availability at enhanced ranges, operating in both LOS and NLOS propagation environments.

ProST operates in the 4.9 to 5.0 GHz ETSI frequency band in time division duplexing (TDD) mode. ProST supports IP services at uplink and downlink over-the-air speeds of up to 37 Mbps over a channel bandwidth of 10 MHz, and up to 18 Mbps over a channel bandwidth of 5 MHz.

ProST uses the OFDM signaling format, providing non line-of-sight (NLOS) performance. ProST utilizes QAM, QPSK, and BPSK modulation technologies by modulating transmitted signals and demodulating the received signals where the original digital message can be recovered. The use of adaptive modulation allows ProST to optimize throughput, yielding higher throughputs while also covering long distances.

ProST provides a built-in, integral antenna. Requiring professional installation, the ProST is installed outdoors on a pole or wall, enabling optimal positioning for best reception with the BS. Outdoor mounting of the ProST is made possible due to ProST's built-in lightning surge protection feature (complying with Surge Immunity standard EN 61000-4-5).

ProST interfaces with the subscriber's LAN through the SDA-1 Type II (referred henceforth as SDA-1) adapter. ProST connects to the SDA-1's 100BaseT interface port by a standard 100-meter CAT-5 cable. The SDA-1 also provides the ProST with 10 to 52 VDC power supply. However, as an alternative to the SDA-1 Type II adapter, Airspan offers two optional integrated LAN switches:

- ❑ **SDA-4S Type II:** integrated LAN switch, providing power and four 10/100BaseT ports for interfacing with the subscriber's network
- ❑ **SDA-4S/VL Type II:** integrated LAN switch, providing power and four 10/100BaseT ports with VLAN functionality for interfacing with the subscriber's network

ProST can be managed by Airspan's AS.MAX Web-based management system using standard Web browsers or alternatively, by an SNMP-based network management system (Netspan) using standard and proprietary MIBs. In addition, external third-party management systems such as HP OpenView can also manage the ProST using these MIBs.

Main Features

The ProST provides the following main features:

- ❑ Full Outdoor Non-LOS Deployment: 256 OFDM
- ❑ Based on field-proven ASWipLL's SPR mechanics
- ❑ Integrated antenna gain of 13 dBi
- ❑ Indoor Ethernet adapter (SDA-1 Type II):
 - providing power and interface termination
 - up to 100-m Category 5 cable between ProST and SDA-1
- ❑ Option of LAN switch with indoor adapter
- ❑ Up to 4 ports with VLAN port switching
- ❑ Integral VoIP (planned for future)
- ❑ E1/T1 (planned for future)

Customer Benefits

The ProST offers the following customer benefits:

- ❑ Based on the latest wireless technology WiMAX IEEE 802.16 standard thereby providing:
 - greater choice of services

- greater choice of access devices
- greater choice of interoperability between technologies
- ▣ High throughput providing fast access at burst data rates of up to 37 Mbps over a channel bandwidth of 10 MHz, and up to 18 Mbps over a channel bandwidth of 5 MHz
- ▣ Low cost

Architecture

The ProST system consists of the following components:

- ▣ Encased ProST outdoor unit
- ▣ SDA-1 Type II indoor adapter (or optional SDA-4S Type II or SDA-4S/VL Type II)
- ▣ Third-party external antenna (optional deployment)

The figure below displays a typical setup of the ProST mounted outdoors on a pole (with an integrated antenna).

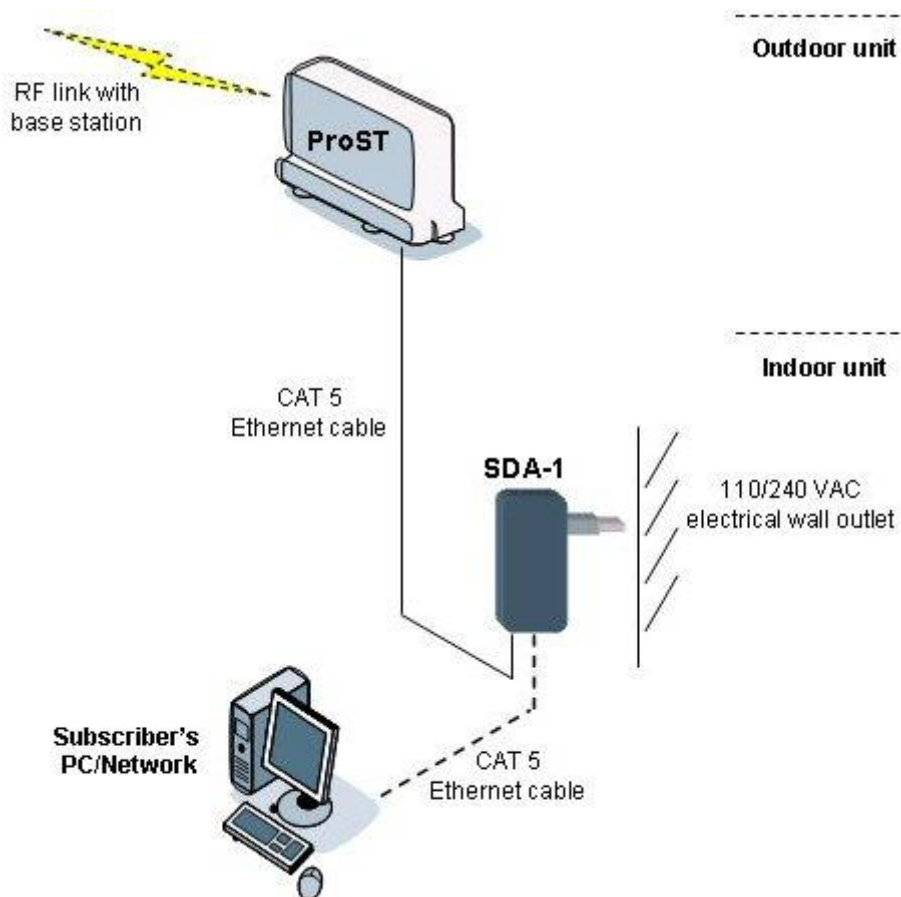

ProST Models

The ProST is available in the following variations, differing in antenna configuration:

- ▣ ProST with built-in (integrated), flat-panel antenna
- ▣ ProST with N-type connector for attaching third-party external antenna (i.e. no integrated antenna)

The ProST model with the integrated antenna is shown below:



The ProST model with the N-type connector for connecting an external antenna is shown below:



ProST Block Diagram

The figure below displays the ProST block diagram:

ProST Protocols Stack

The figure below displays a block diagram of the ProST's network architecture, designed as a hierarchy of protocols (i.e. protocol stack) implemented in the communication network.

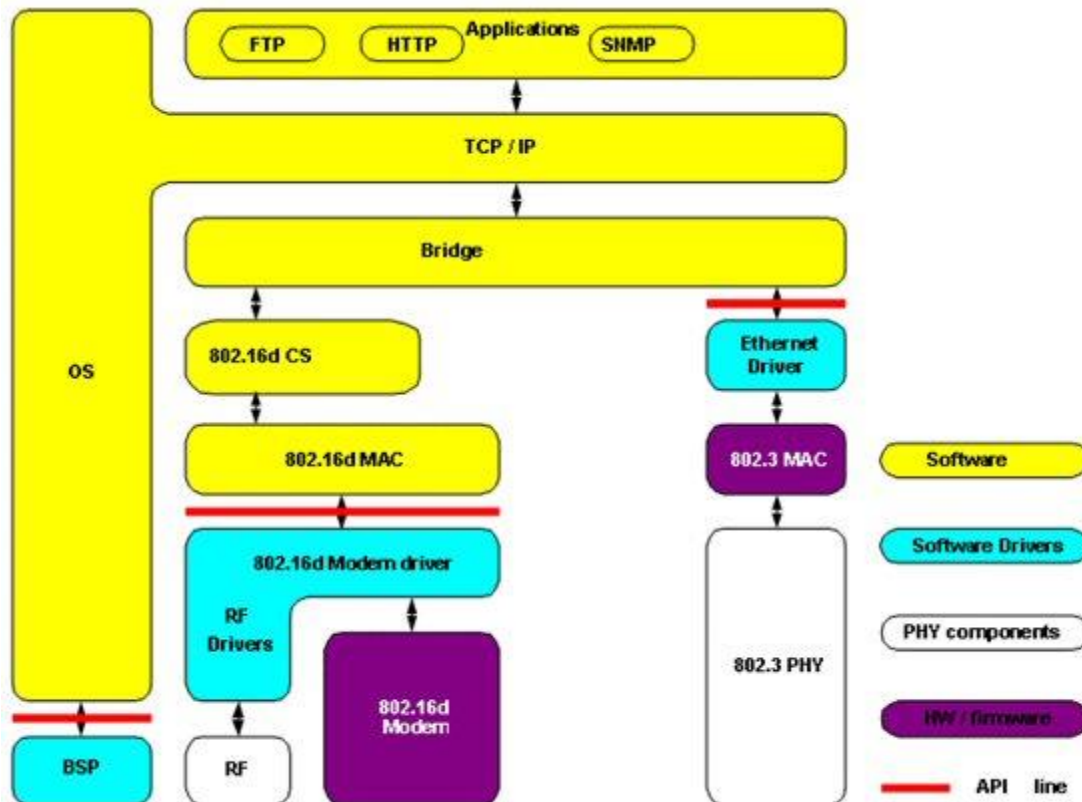

Theory of Operation

For basic operation, the ProST requires no initial configuration--simply plug and play. Configuration is automatically performed over the air by the BS. The ProST is preconfigured by the operator at the BS (using Netspan) with service flow parameters such as the maximum information rate, the committed information rate, the maximum latency, and maximum jitter. These configuration parameters are stored in Netspan's database corresponding to the ProST's MAC address.

Before any communication between ProST and BS can occur, the ProST must be positioned in a location that provides sufficient RF reception.

To join a network, the ProST needs to perform a few tasks. First, the "Network Entry" process (defined in 802.16-2004) begins with the ProST scanning for a downlink (DL) signal from the base station, and then synchronizing to the DL channel. Thereafter the ProST can start the process of initial ranging, which alerts the BS to the presence of the ProST and establishment of management connections to obtain basic and primary management connection IDs (CID) from the BS. After the CIDs have been obtained, the ProST commences authorization and key exchange. In the final stage, the ProST registers at the base station before obtaining the IP address, time of day and the configuration file.

During Network entry, the ProST sends the BS its MAC address. The BS then accesses Netspan's database (via SNMP) and checks whether the ProST's MAC address appears in the DB. If it locates the MAC address, the BS retrieves all the ProST's configuration parameters (service flows) from the DB and downloads them to the ProST device.

GETTING STARTED

Before installing your ProST, read the following topics to ensure that:

- ▶ [No items are missing from the package](#)
- ▶ [Minimum computer requirements are fulfilled](#)
- ▶ [You have the required installation tools](#)
- ▶ [Radio Site planning has been performed](#)

Package Contents

Examine the AS.MAX shipping container. If you notice any damage, or missing items as listed in the Packing List, immediately notify the carrier that delivered the unit and contact an Airspan representative.

The ProST kit should contain the following items:

- ▶ ProST Radio
- ▶ DB15-to-RJ45 adapter for plugging into the ProST's 15-pin D-type port
- ▶ CAT 5 cable
- ▶ Wall-mounting kit:
 - Mounting bracket
 - 2 x M10 hex head screws
 - 2 x M10 hex nuts
 - 2 x M10 plain washers
 - 2 x M10 spring lock washers

 **Note:** The standard ProST kit does not include pole-mounting accessories. For pricing and ordering of pole-mounting accessories, please contact your nearest Airspan dealer.

 **Note:** The standard ProST kit does not include the SDA-1 Type II adapter. For pricing and ordering of the SDA-1 Type II adapter, please contact your nearest Airspan dealer.

Minimum PC Requirements

Ensure that your computer provides an Ethernet interface such as a Network Interface Card (that provides an RJ-45 port).

 **Note:** Only subscriber terminal equipment (e.g. computer modem port) that is designed for full compliance with TNV-1 telecommunication network can be connected to the SDA-1. Warranty of Airspan's equipment shall be made void if the SDA-1 is connected to a computer that is not compliant with TNV-1.

Required Tools

The following tools are required to install the ProST unit:

- ▶ Crimping tool for crimping CAT-5 cables to RJ-45 connectors
- ▶ Cable stripping tool
- ▶ Wall Mounting:
 - drill bits
 - 4 x wall anchors
 - 4 x screws
 - Philips head screwdriver
 - Flat-blade screwdriver
 - A/F open ended spanner
- ▶ Crimping tool for crimping RF cable to N-type connector (only relevant when implementing external antenna)

- ▶ Torque wrench for N-type connectors (only relevant when implementing external antenna)

 **Note:** Airspan does not provide screws and wall anchors for mounting the ProST to the wall. The screw size depends on the structure of the building to which the ProST is to be attached. When selecting screw sizes, consideration must be given to the weight of the ProST and load that may be induced in windy conditions.

Radio Site Planning

Proper site selection and planning before installing your ProST will ensure a successful deployment of your AS.MAX system. A summary of the main site planning considerations is provided below:

- ▶ Minimum obstructions (e.g. buildings) in the radio path between base station and the ProST
- ▶ Mount radio as high as possible to avoid obstructions in the wireless path
- ▶ Check possibility of future obstructions such as plans to erect buildings and trees that may grow tall enough to obstruct the wireless path
- ▶ Minimum incursions on Fresnel Zone (recommended minimum of 60% clearance of first Fresnel Zone)
- ▶ Align radio for maximizing received signal strength (RSS)
- ▶ Consider nearby sources of interference that could degrade performance of radio
- ▶ Mount radio as far from sources of interference as possible
- ▶ Ensure base station and ProST are within maximum coverage range of reception
- ▶ Maximum standard CAT-5 cable length connecting the outdoor ProST to the indoor SDA-1 is 100 meters.
- ▶ Ensure that you have sufficient wiring conduit and cable ties to channel and protect the CAT 5 cable connecting the outdoor ProST to the indoor SDA-1.

Minimal Radio Path Obstructions

AS.MAX radios communicate by propagation of waves. Thus, ensure minimum obstructions (from, e.g. buildings and trees) in the radio path between base station and ProST. It is essential that the ProST is installed in such a way that the radio path with the base station has a clear path with each other.

Fresnel Zone Clearance

There must be sufficient open space around the radio path to minimize blocking of the radio beam. A minimum of 60% of the first Fresnel Zone of the path should be clear of obstructions. Despite a clear line-of-sight, objects close enough to the transmission path may cause attenuation in signal strength and an increase in signal interference. Objects with reflective surfaces that seem relatively far away, but yet still encroaching on Fresnel Zone, may cause these interferences.

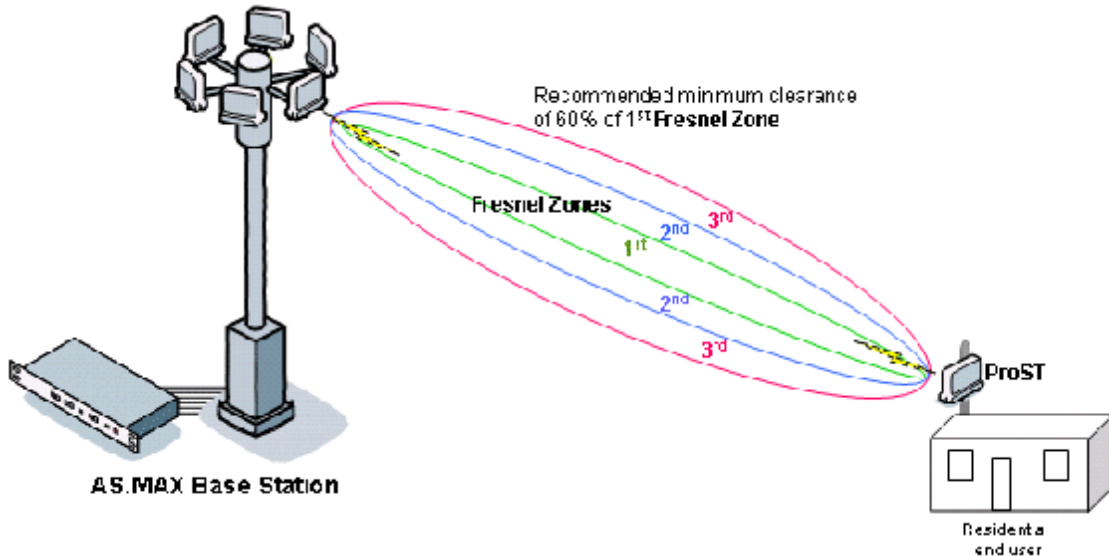

Fresnel Zones define the amount of clearance required from obstacles. These zones are composed of concentric ellipsoid areas surrounding the straight-line path between two antennas. Thus, the zone affects objects to the side of the path and those directly in the path. The first Fresnel Zone is the surface containing every point for which the distance from the transmitter to any reflection point on the surface point and then onto the receiver is one-half wavelength longer than the direct signal path.

One method for clearing the Fresnel Zone is by increasing the antenna height.

The first Fresnel Zone radius is calculated by the following equation:

$$r = \sqrt{\frac{75 \cdot d}{f}}$$

Where f is the frequency (in MHz) and d is the distance (in meters) between the ProST and the base station.

For example, using the formula above, a link of 4 km at 4,900 MHz produces a first Fresnel Zone radius clearance of about 61 meters. This implies that to ensure the ground does not enter into the first Fresnel Zone, both radios (i.e. at base station and subscriber) must be mounted at least 20 meters above ground level (or clutter level). Typically, at least 60% clearance of the first Fresnel Zone is considered as LOS. Therefore, in the above example, a height of at least 36 meters (i.e. 60% of 61 meters) above ground level is sufficient for LOS.

Multipath Fading

Some of the transmitted signals may be reflected from a nearby building, by water under the signal path, or from any other reflectors. This reflected signal may be reflected from a nearby building, by water under the signal path, or from any other reflectors. This reflected ("bounced") signal can then be received by the radio receiving the signal and superimposed on the main received signal, thereby degrading the signal strength.

To avoid multipath fading from nearby buildings etc., Airspan recommends installing the ProST at the rear end of buildings instead of at the front. When you install at the rear end of the building, the front-end of the building blocks incoming signals from multipath reflections.

Radio Antenna Alignment

Once the ProST is installed and aimed in the general direction of the base station, it is recommended to measure the received signal strength (RSS) to determine the signal strength received from the base station, and to precisely align the ProST for maximum signal strength. You need to orientate (up/down, left/right) the ProST until the maximum RSS levels are achieved, and then secure the ProST. (For viewing the received signal strength, see "ProST Web-Based Management".

PHYSICAL DESCRIPTION

This section provides a description of the components of the ProST installation:

- ▶ [ProST radio \(outdoor unit\)](#)
- ▶ [SDA-1 adapter \(indoor unit -- switch and power interface\)](#)
- ▶ [SDA-4S Type II and SDA-4S/VL Type II adapters](#) (optional)

ProST

The ProST is an encased outdoor radio providing access to communication ports on its front panel. The ProST's bottom panel provides holes for mounting.

Physical Dimensions

The table below lists the physical dimensions of the ProST.

Parameter	Value
Dimensions (H x W x D)	▶ 223 x 311 x 105 mm (8.78 x 12.24 x 4.13 inches)
Weight	▶ 1.97 kg (approximate)

The figure below illustrates the ProST's physical dimensions.

Port

The ProST provides a 15-pin D-type port for interfacing with the SDA-1. For convenience, a DB15-to-RJ45 adapter is supplied for attaching to the 15-pin D-type port to allow the use of RJ-45 connectors for outdoor-to-indoor CAT 5 connectivity.

For ProST models implementing third-party external antennas, an N-type port is also provided on the front panel.

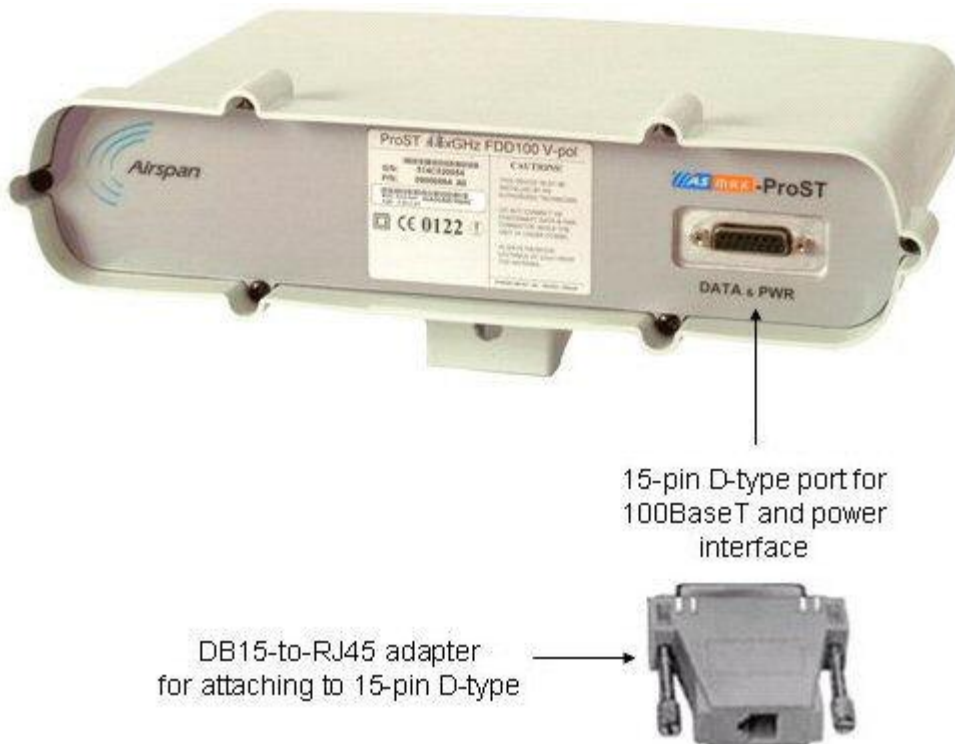

SDA-1 Physical Description

The SDA-1 is an integrated Ethernet and AC/DC power supply adapter that simply plugs into a standard electrical wall outlet (110/240 VAC). The SDA-1 provides the ProST with the following:

- 10/100BaseT interface with subscriber's network/PC
- 10 to 52 VDC power supply

The SDA-1 enables easy plug prong replacement to suit geographical location of electrical outlet sockets (e.g. American vs. European).

The SDA-1 physical description (i.e. ports, LED, and prongs) are displayed in the figure below:

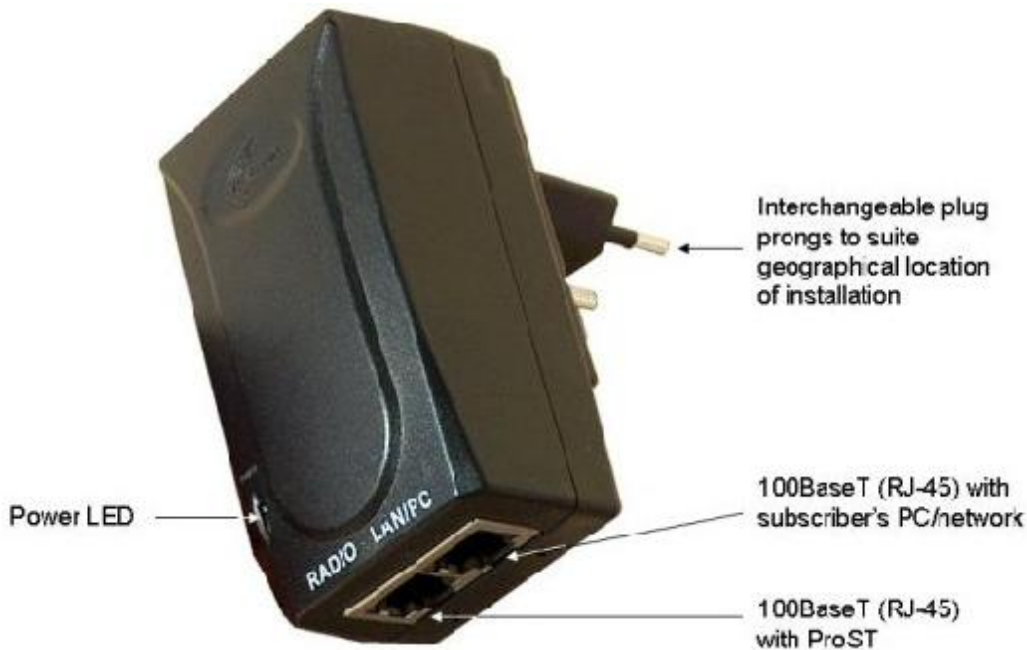

Physical Dimensions

The table below lists the physical dimensions of the SDA-1.

Parameter	Value
Dimensions (H x W x D)	72 x 42.5 x 26 mm (2.83 x 1.67 x 1.02 inches)
Weight	0.159 kg

Ports

The SDA-1 provides two ports, as described in the table below:

Port	Label	Interface
8-pin RJ-45	RADIO	10/100BaseT with ProST radio
8-pin RJ-45	LAN/PC	10/100BaseT with subscriber's network

LED

The SDA-1 provides a green power LED (labeled POWER), located on its front panel. This LED light not only indicates the presence of power supply, but also can indicate incorrect SDA-1 port assignment for the network cables, i.e. from the ProST and computer. For a detailed description of the POWER LED, see Appendix C, "Troubleshooting".

SDA-4S Type II and SDA-4S/VL Type II (Optional)

The SDA-4S Type II and SDA-4S/VL Type II indoor units (hereafter referred to as *SDA-4S* for convenience) are two optional integrated LAN switches that offer an alternative to the SDA-1 Type II unit. These two units have identical physical dimensions and design, as displayed in the figure below.

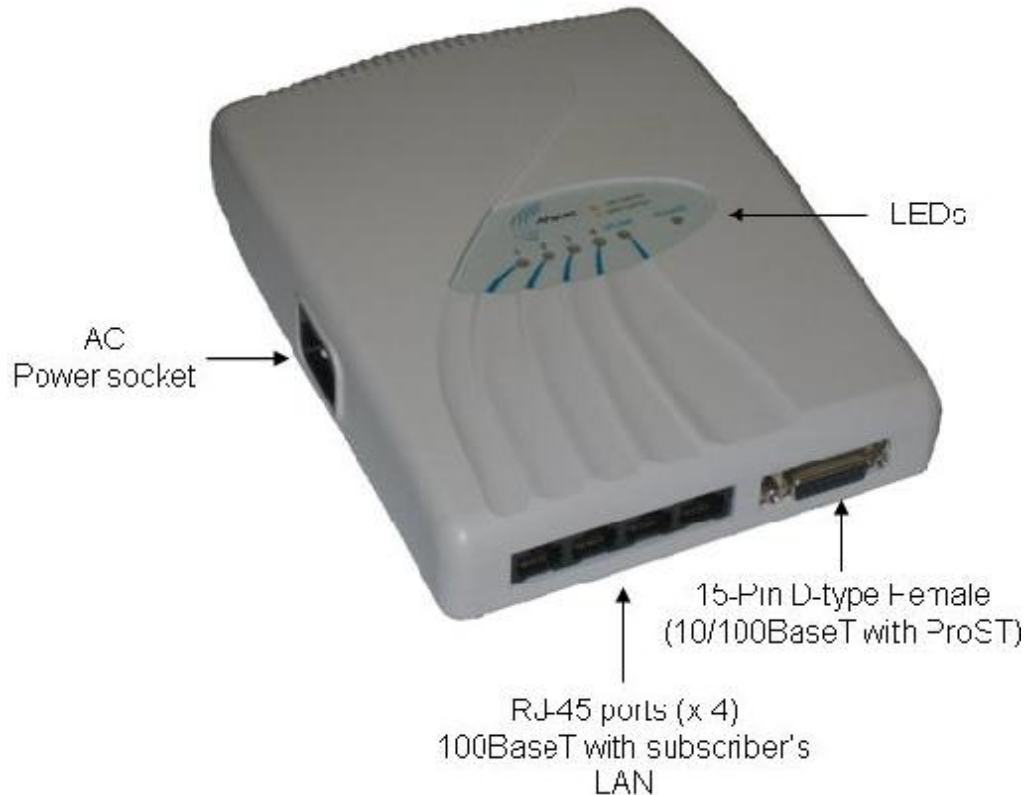

Physical Dimensions

The SDA-4S Type II and SDA-4S/VL Type II physical dimensions are described in the table below:

Parameter	Value
Dimensions (L x W x H)	200 x 150 x 40 mm (7.87 x 5.9 x 1.57 inches)
Weight	0.577 kg

Ports

The SDA-4S Type II and SDA-4S/VL Type II adapters provide ports on their front panels, which are described in the table below:

Port	Interface
4 x 8-pin RJ-45	10/100BaseT with subscriber's network (supports Auto Negotiation and MDI/MDI-X automatic crossover, allowing connection of straight-through or crossover cables)
15-pin D-type (female)	10/100BaseT with ProST
AC power socket	Subscriber's power outlet (110/240 VAC, 50/60 Hz)

 **Note:** The ports of the SDA-4S models support Auto Negotiation, allowing automatic configuration for the highest possible speed link (10BaseT or 100BaseT), and Full Duplex or Half Duplex mode. In other words, the speed of the connected device (e.g. PC)

determines the speed at which packets are transmitted through the specific SDA-4S port. For example, if the device to which the port is connected is running at 100 Mbps, the port connection will transmit packets at 100 Mbps. Conversely, if the device to which the port is connected is running at 10 Mbps, the port connection will transmit packets at 10 Mbps.

In addition, the SDA-4S ports support MDI/MDI-X automatic crossover, allowing connection to straight-through or crossover cables.

LEDs

The SDA-4S Type II and SDA-4S/VL Type II adapters (referred to as SDA-4S) provide LED indicators on their top panels, which are described in the table below:

LED	Color	Status	Meaning
UPLINK	Yellow (100BaseT) or Orange (10BaseT)	On	Physical link (10BaseT or 100BaseT) between SDA-4S adapter and ProST
		Blinking	Traffic currently flowing between SDA-4S and ProST
		Off	No link between SDA-4S and ProST
1, 2, 3, 4	Yellow (100BaseT) or Orange (10BaseT)	On	Physical link (10BaseT or 100BaseT) between SDA-4S and subscriber's Ethernet network
		Blinking	Traffic currently flowing between SDA-4S and subscriber's Ethernet network
		Off	No link between SDA-4S and subscriber's Ethernet network
POWER	Green	On	Power received by SDA-4S
		Off	No power received by SDA-4S

The figure below displays the LEDs which are located on the top panel of the SDA-4S Type II and SDA-4S/VL Type II adapters:

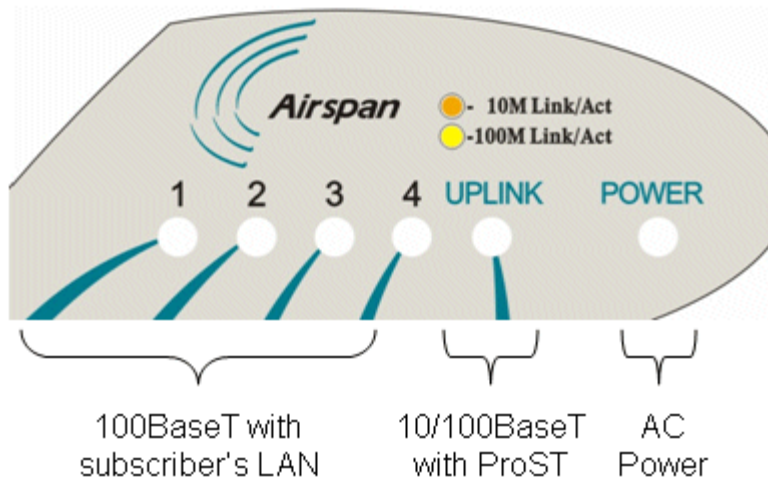

MOUNTING



Warning: ProST is an outdoor radio unit, and therefore, must only be mounted outdoors.



Warning: Mount the ProST in an orientation such that its 15-pin D-type port (located on the front panel) faces downwards. This prevents rain water from settling on the port, and thereby, avoiding damage to the unit such as corrosion and electrical short-circuiting.

ProST can be [wall mounted](#) or [pole mounted](#). For either mounting methods, the ProST provides mounting holes (displayed in the figure below), molded into its bottom panel for attaching the mounting brackets.

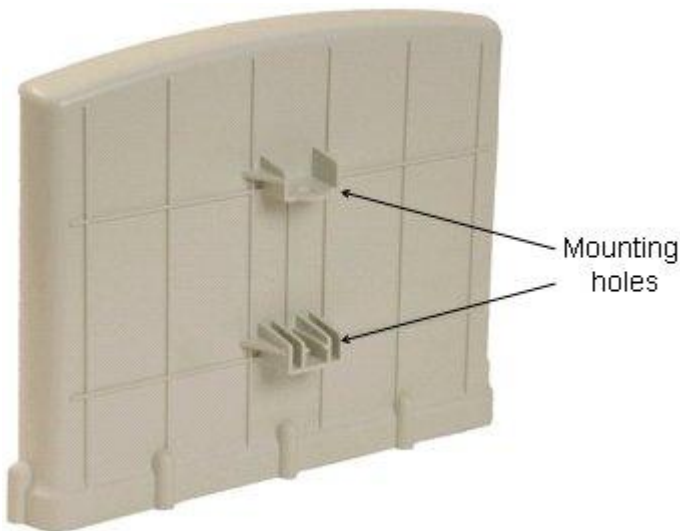

Note: The standard ProST kit provides wall-mounting brackets. If you want to pole mount the ProST, contact your nearest Airspan distributor for pricing and ordering of pole-mounting brackets.



Note: A minimum of 3-meter separation is required between mounted ProSTs and existing customer radio equipment when transmitting on different sectors (see figure below). However, only a 1-meter separation is required between ProSTs when on the same sector and transmitting to the same base station radio without requiring shielding.

The figure below illustrates the minimum separation between mounted ProST's when transmitting on different sectors:

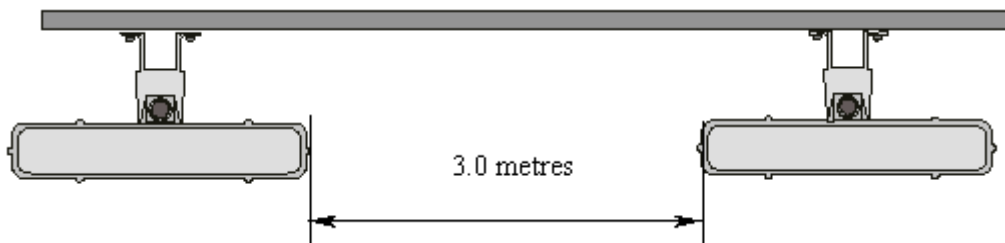

Wall Mounting

ProST wall mounting consists of two main stages:

- ▣ Attaching the mounting bracket to the ProST's mounting holes
- ▣ Attaching the mounting bracket (already attached to the ProST) to the wall (or pole)

To wall mount the ProST:

1. Position the unassembled mounting bracket on the mounting surface (e.g. wall), and then use a pencil to mark the position of the four mounting holes. Ensure that the distance between the hole centers are 120 mm (height) and 60 mm (width), as displayed in the figure below showing the ProST's fixing dimensions.

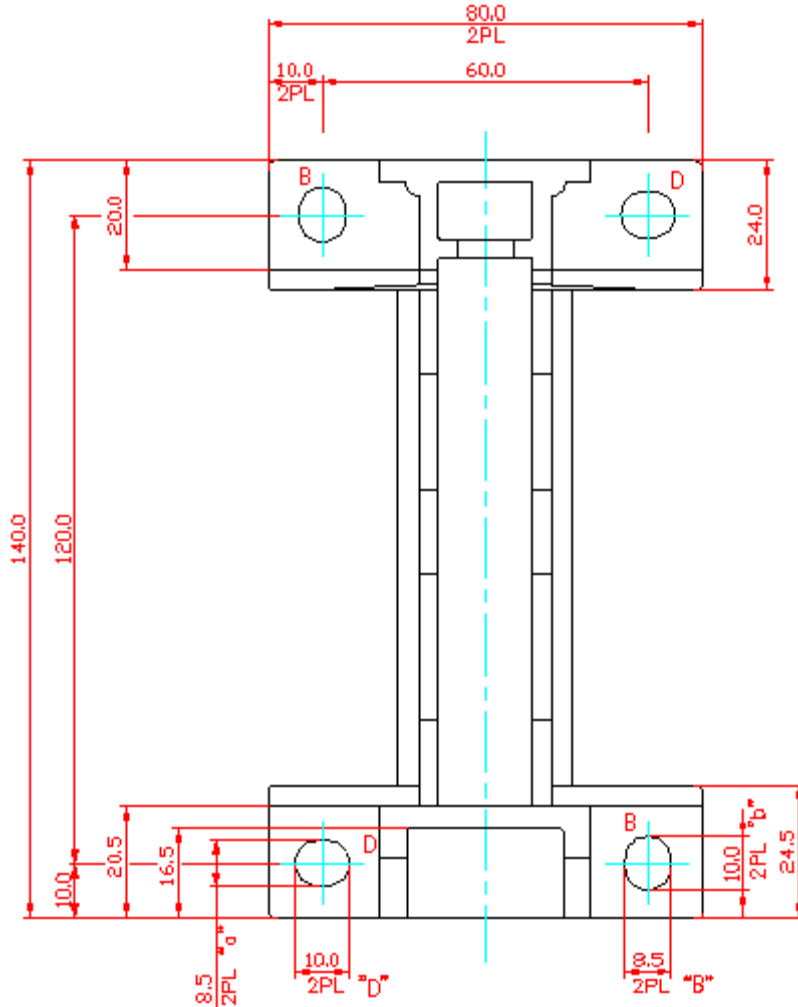

2. Drill holes for each hole that you marked in the step above.
3. Insert wall anchors (not supplied) into each of the drilled holes.
4. Align the mounting bracket's four holes with the wall anchors, and then insert a screw (not supplied) through the mounting bracket holes into each wall anchor, and then tighten.

 **Note:** Airspan does not provide screws for attaching the mounting bracket to the wall. The screw size depends on the structure of the building to which the bracket is to be attached. When selecting screw sizes, consideration must be given to the weight of the ProST and load that may be induced in windy conditions.

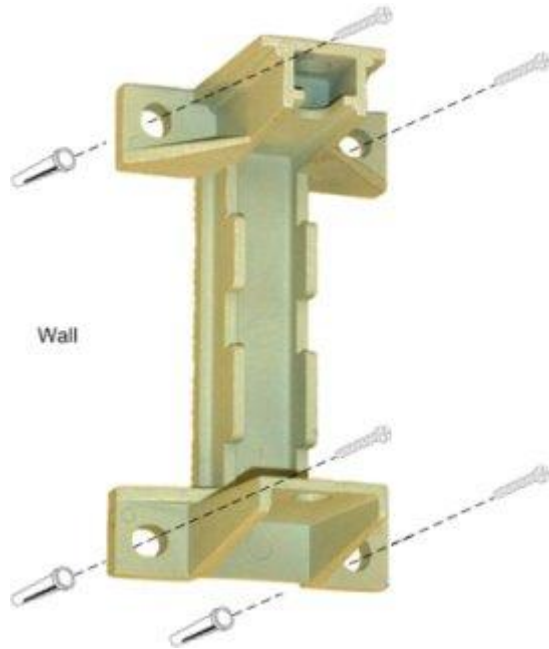

5. Attach the ProST to the mounting bracket by performing the following:
 - a. Slide an M10-spring lock washer and then an M10-plain washer onto each M10-hex head screw (ensure lock washer is nearest to head of screw bolt).
 - b. Align the mounting bracket's holes with the ProST's mounting holes as displayed below. (The mounting bracket side that provides a groove for inserting a nut must be aligned with the ProST's mounting hole that is nearest to the ProST's rear panel.)
 - c. From the external sides, insert the M10-hex head screws through the mounting bracket's holes and ProST's mounting holes. Loosely fasten with the M10-hex nuts.

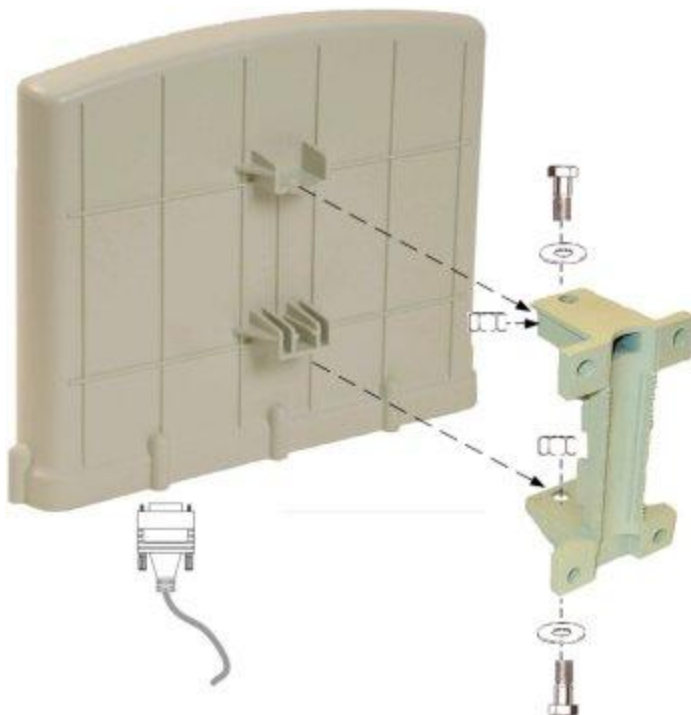

6. Adjust the horizontal positioning of the ProST (see "Web-Based Management" for ProST antenna alignment using RSS measurements), and then tighten the two M10-hex head screws with the M10 hex nuts.

 **Note:** A third-party thread-locking compound must be applied to the M10-hex head screws to prevent the bolts from working loose.

For wall mounting, rotation is restricted in the horizontal plane only, as shown in the figure below (top view):

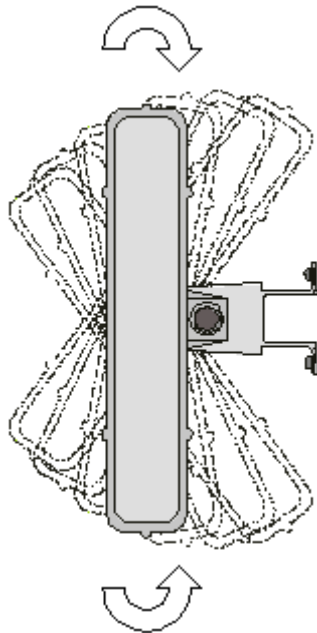

Pole Mounting

Pole mounting allows the ProST to be easily adjusted in the horizontal (azimuth) and vertical (elevation) planes for antenna alignment. The ProST is mounted using the mounting holes located on the ProST's bottom panel and the supplied (when ordered) pole-mounting brackets. The pole-mounting bracket is designed to support the ProST on a round pole of 45 mm in diameter.

The below figure illustrates a summary of the ProST pole-mounting procedure.

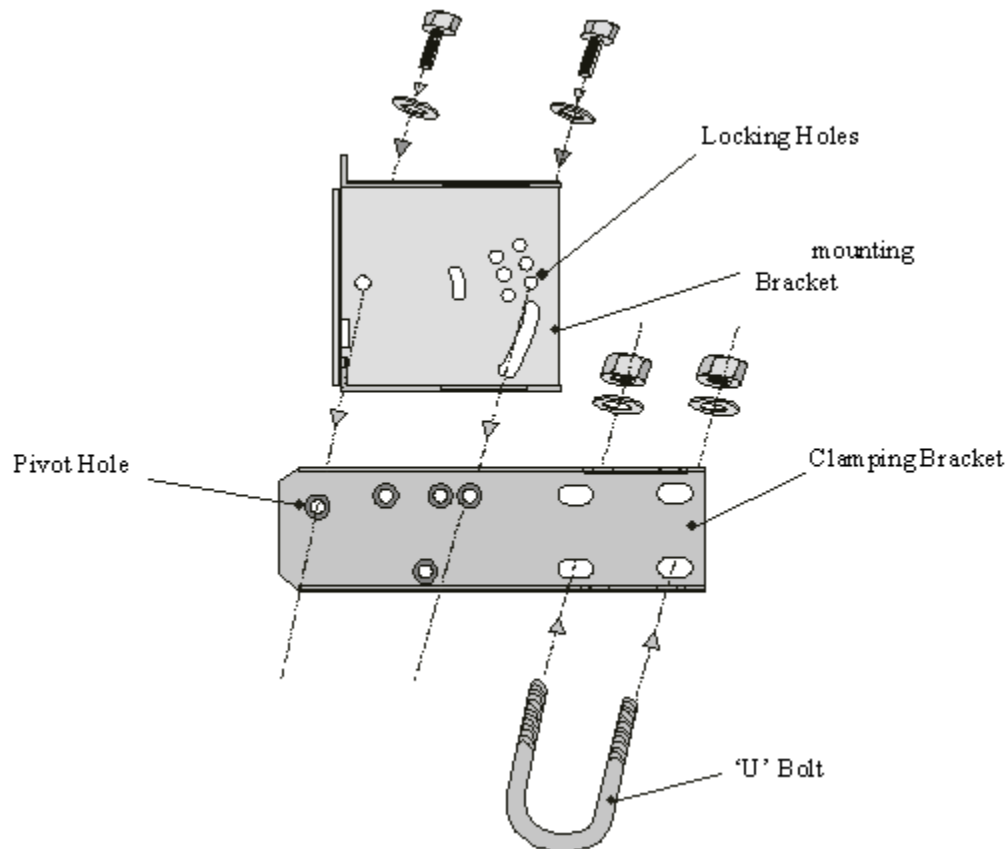

To pole mount the ProST:

1. Attach the mounting bracket to the ProST:
 - a. Align the mounting bracket with the ProST's mounting holes so that the mounting bracket's side with the built-in nut is aligned with the ProST's mounting holes furthest from the ProST's front panel, as shown in the figure below.
 - b. Slide an M10-flat washer and M10-spring lock washer onto an M10-hex head screw (ensure spring lock washer is closest to the bolt's head). From the external side, insert the M10-hex head screw through the mounting bracket and ProST's mounting holes. Fasten the M10-hex head screw (one is provided with a built-in nut while the other requires you to insert an M10-hex nut into the ProST's mounting hole).

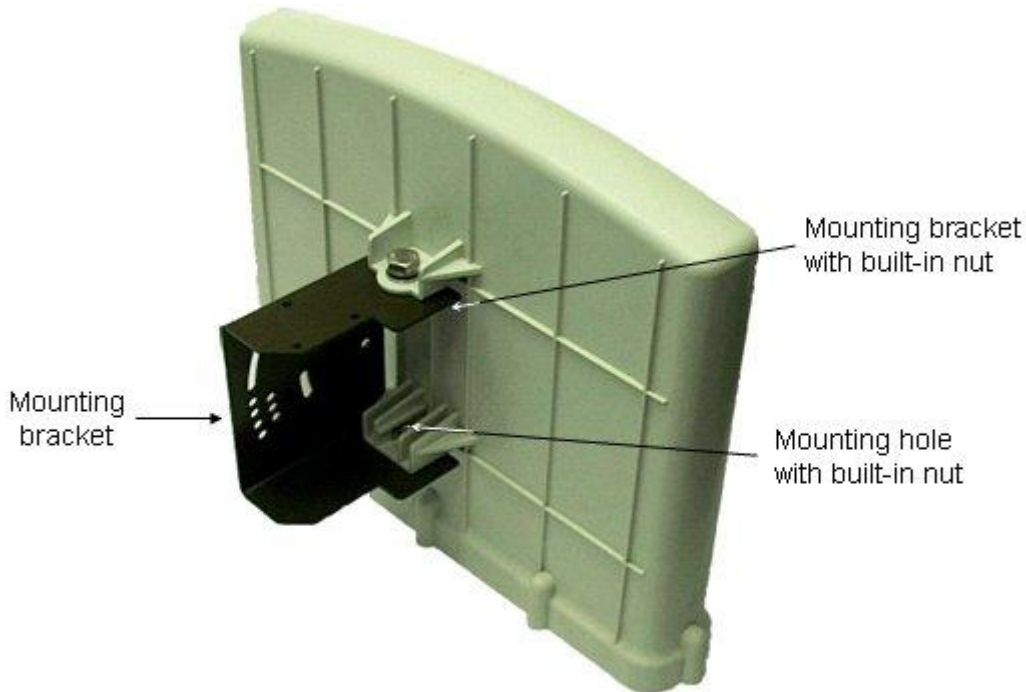

2. Attach the clamping bracket to the mounting bracket:
 - a. Slide an M6-spring lock washer onto an M6-hex head screw. Align the mounting bracket's and clamping bracket's pivot holes, such that the clamping bracket is aligned to the inside of the mounting bracket. From the external side of the mounting bracket, insert the M6-hex head screw into the pivot holes and then fasten, but not tightly. (The clamping bracket provides a built-in nut.)
 - b. Choose an elevation hole on the mounting bracket and then align it with the corresponding hole on the clamping bracket. Slide an M6-spring lock washer onto an M6-hex head screw, and then from the external side of the mounting bracket, insert the M6-hex head screw through the elevation hole on the mounting bracket and into the clamping bracket's corresponding hole. Fasten but not tightly the M6-hex head screw (the clamping bracket provides built-in nut). The elevation hole can later be changed according to desired antenna orientation in the elevation plane.

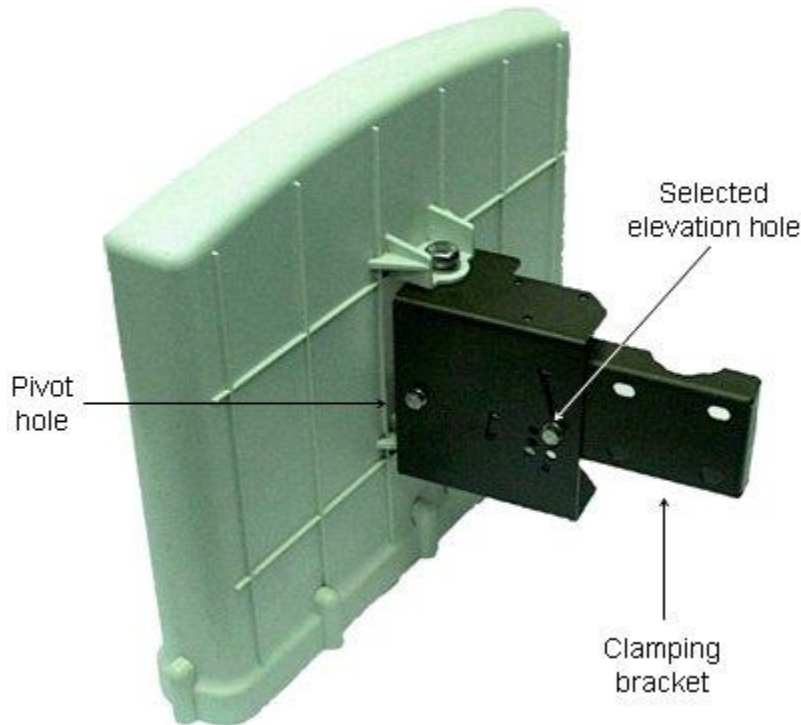

3. Attach the U-bolt to the pole:

- a. Place one U-bolt around the pole, and then insert the U-bolt screw side through the two corresponding holes (horizontally parallel) on the clamping bracket. Slide an M8-flat washer and M8-spring lock washer onto each U-bolt screw side (ensure that the flat washer is adjacent to the clamping bracket). Fasten each U-bolt side with the two M8-hex nuts.
- b. Attach the second U-bolt as described above.

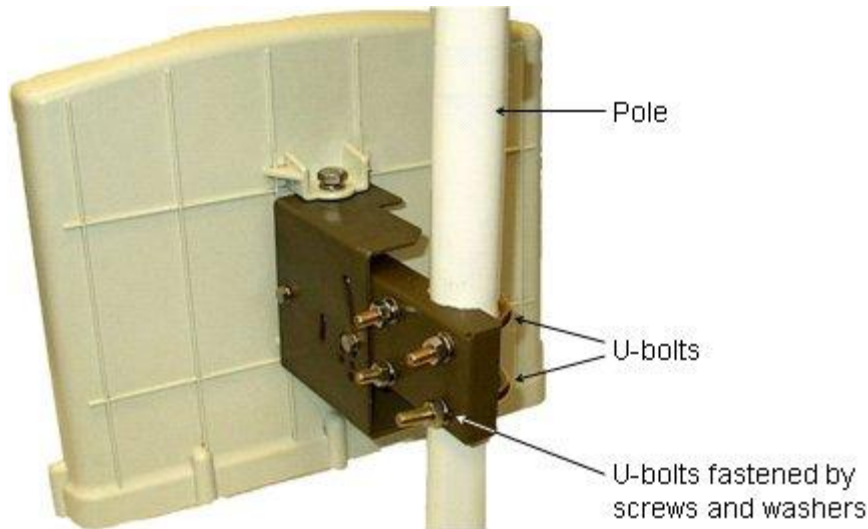

4. Perform final ProST orientation:

- a. Adjust the vertical position of the ProST by choosing a final elevation hole as described in Step 2. Lock the ProST at the desired position by inserting the locking bolt in the desired position and fastening it tightly. Fasten tightly the bolt in the pivot hole. The figure below illustrates the angles (in degrees) of each elevation hole. As shown, the ProST pole-mounting bracket allows elevation between -18.5° and 26.3° .
- b. Adjust the horizontal position of the ProST by rotating it about the pole, and then tightening the nuts of the U-bolts.

 **Note:** A thread-locking compound must be used to prevent the bolts from working loose.

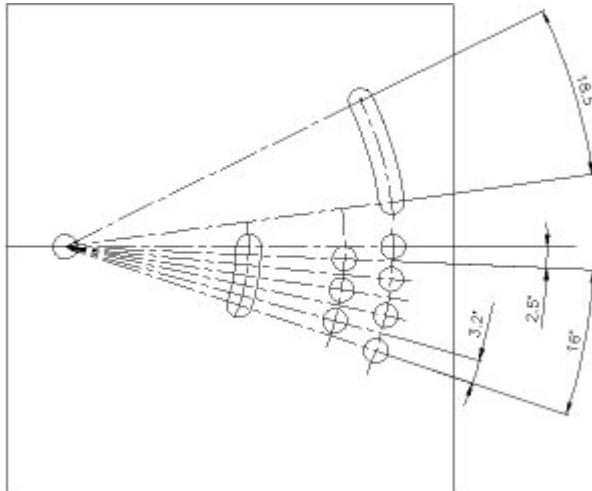

ProST positioning is obtained in two planes by adjustment of the mounting bracket assembly as shown below:

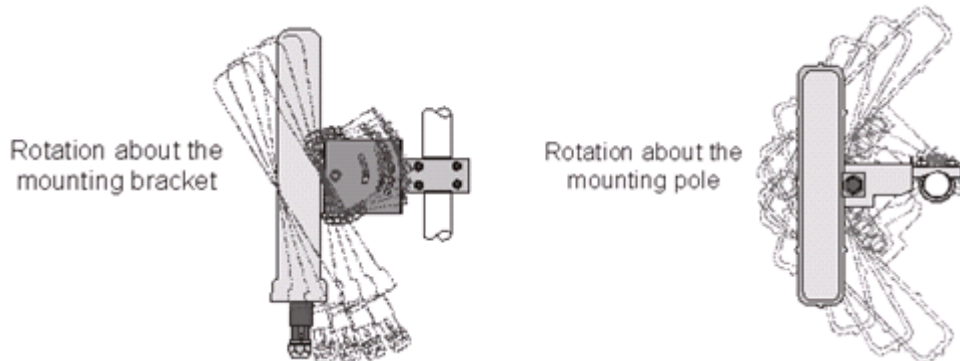

It is important to provide strain relief and drip loop for Cat-5 cables. Create a drip loop and strain relief using cable tie, to tie cable to pole, as displayed in the figure below:



SDA-4S

The SDA-4S adapters can be mounted either horizontally on a desktop or vertically on a wall.

Desktop Mounting

Desktop mounting is made possible by the existence of four feet, each located on the four corners of the SDA-4S bottom panel. Therefore, no installation is necessary for desktop mounting.



Warning: To prevent a fire hazard caused by overheating, do not place the SDA-4S on a carpeted surface where airflow is restricted.

Wall Mounting

Wall mounting is made possible by the existence of two mounting hooks molded into the SDA-4S's bottom panel, as displayed in the figure below.

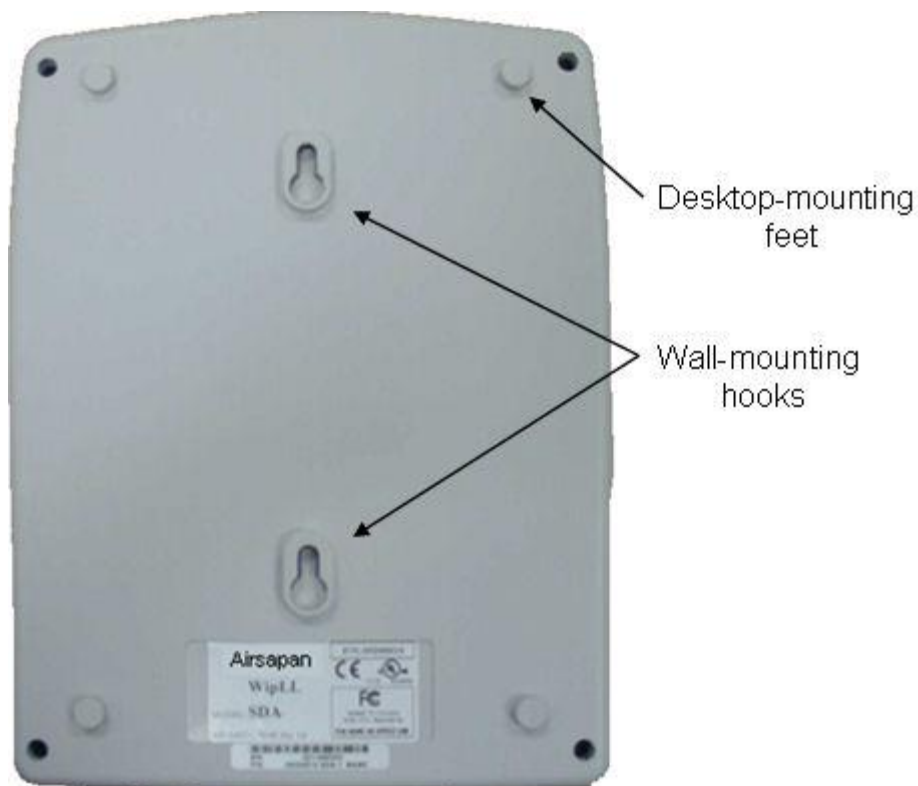

To wall mount the SDA:

1. On the wall, mark the position of the two mounting hooks. The dimensions of the wall-mounting hooks are displayed in the template below.

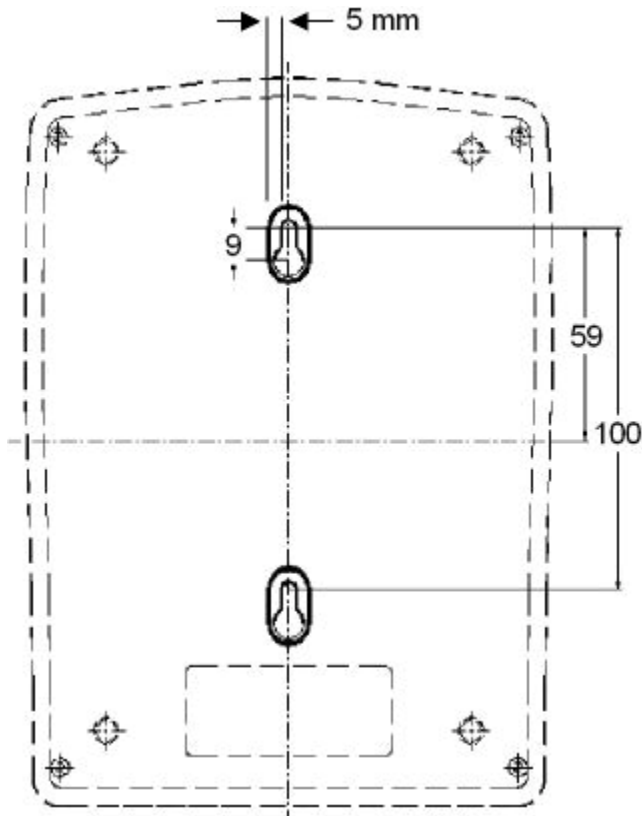

2. Drill holes for each hole that you marked in the step above.
3. Insert wall anchors (supplied) into each of the drilled holes.
4. Insert the 9-inch screws (supplied) into the wall anchors. Ensure at least 2 mm of the screw is exposed to allow insertion into the SDA-4S mounting holes.
5. Hold the SDA-4S with both hands, and align the entrance to the two mounting hooks with the screws. Slide the screws into the mounting hooks, by lowering the SDA-4S onto the screws.

 **Note:** For safety, both mounting hooks must be utilized when mounting the unit.

 **Note:** The SDA-4S is supplied with a 1-metre AC power lead assembly. Therefore, ensure the unit is mounted within reachable distance to the customer's mains power outlet.

 **Note:** The maximum cable run between SDA-4S and ProST is 100 meters. Therefore, ensure the unit is mounted within reachable distance to the ProST.

CABLING THE PROST

The ProST interfaces with the subscriber's network through the IDU (i.e. typically the SDA-1 Type II, or optionally through the SDA-4S Type II or SDA-4S/VL Type II). The ProST also receives DC power from the IDU.

This section describes the ProST cabling:

- ▶ [Connecting ProST to SDA-1](#)
- ▶ [Connecting ProST to SDA-4S](#)
- ▶ [Connecting ProST to a Computer](#)
- ▶ [Connecting ProST to Power](#)

CONNECTING PROST TO SDA-1

The ProST connects to the SDA-1 using a CAT 5 cable with 8-pin RJ-45 connectors on either end. The ProST provides a 15-pin D-type port for interfacing with the SDA-1. However, for allowing the use of RJ-45 connectors, your ProST kit includes a DB15-to-RJ45 adapter that can easily be attached to the ProST's 15-pin D-type port.

The cable setup for ProST-to-SDA-1 connectivity is as follows:

- ▶ **Cable:** Straight-through CAT 5 Ethernet cable
- ▶ **Connectors:** 8-pin RJ-45
- ▶ **Connector pinouts:**

Wire color	Wire pair	Pin	Function
Blue/White	1	5	+48 VDC
Blue		4	48 RTN
Orange/White	2	1	Rx+
Orange		2	Rx-
Green/White	3	3	Tx+
Green		6	Tx-



Notes:

- Only pins 1 to 6 are used.
- Pins 7 and 8 should **not** be wired to the ProST end.
- The wire color-coding described in the table is AS.MAX's standard for wire color-coding. However, if you implement your company's wire color-coding scheme, ensure that the wires are paired and twisted according to pin functions listed in the table above (e.g. Rx+ with Rx-).

To connect the ProST to the SDA-1:

1. Attach the DB15 side of the DB15-to-RJ45 adapter to the ProST's 15-pin D-type port (female).
2. Plug the RJ-45 connector of the Category 5 Ethernet cable (not supplied) into the RJ-45 port of the DB15-to-RJ45 adapter.
3. Plug the RJ-45 connector, at the loose end of the Category 5 Ethernet cable, into the SDA-1's RJ-45 port labeled **RADIO**.

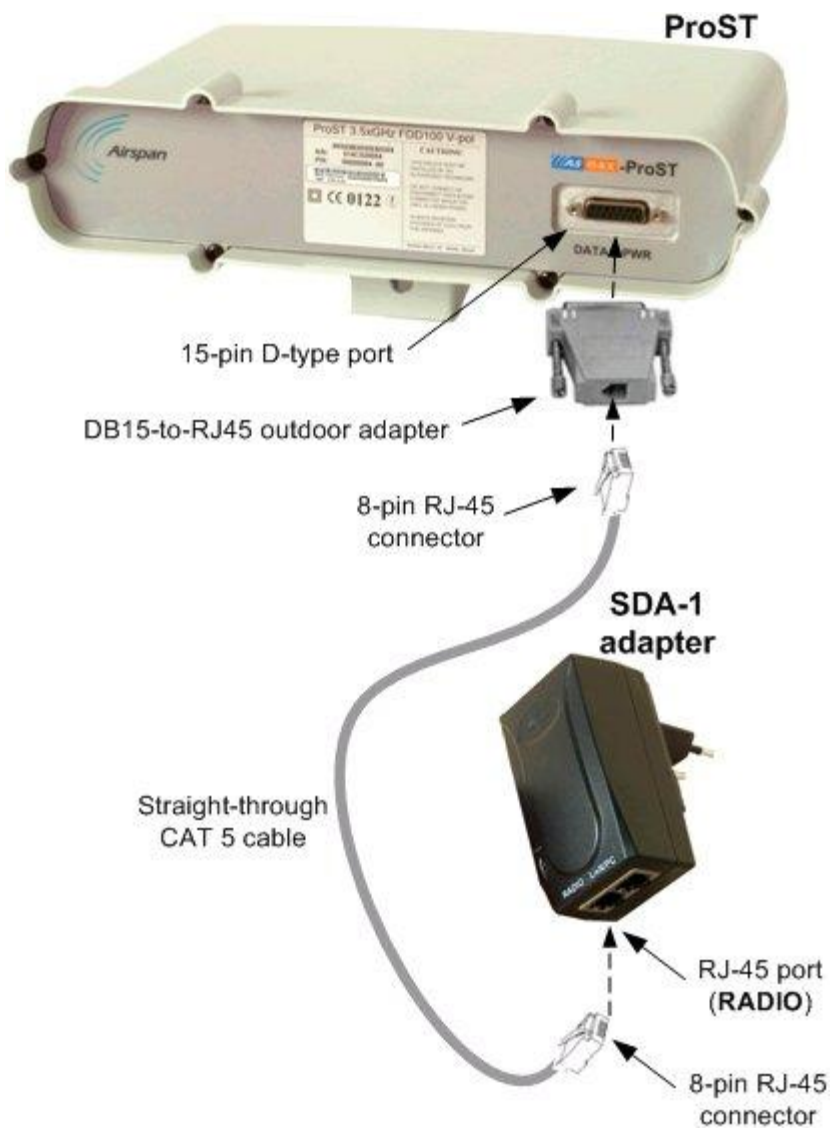

CONNECTING PROST TO SDA-4S

The ProST connects to the SDA-4S or SDA-4S/VL using a CAT 5 cable with 8-pin RJ-45 connectors on either end. The ProST provides a 15-pin D-type port for interfacing with the SDA-4S. However, for allowing the use of RJ-45 connectors, your ProST kit includes a DB15-to-RJ45 adapter that can easily be attached to the ProST's 15-pin D-type port.

The cable setup for ProST-to-SDA-4S connectivity is as follows:

- ▣ **Cable:** Straight-through CAT 5 Ethernet cable
- ▣ **Connectors:**
 - **ProST:** DB15-to-RJ45 adapter
 - **SDA-4S:** DB15-to-RJ45 adapter
 - CAT 5 cable with 8-pin RJ-45 male connectors on either end
- ▣ **Connector pinouts:**

Wire color	Wire pair	Pin	Function
Blue/White	1	5	+48 VDC
Blue		4	48 RTN
Orange/White	2	1	Rx+
Orange		2	Rx-
Green/White	3	3	Tx+
Green		6	Tx-



Notes:

- Only pins 1 to 6 are used.
- Pins 7 and 8 should **not** be wired to the ProST end.
- The wire color-coding described in the table is AS.MAX's standard for wire color-coding. However, if you implement your company's wire color-coding scheme, ensure that the wires are paired and twisted according to pin functions listed in the table above (e.g. Rx+ with Rx-).

To connect the ProST to the SDA-4S:

1. Attach the DB15 side of the DB15-to-RJ45 adapter to the ProST's 15-pin D-type port (female), labeled **DATA & PWR**.
2. Attach the DB15 side of the second DB15-to-RJ45 adapter to the SDA-4S's 15-pin D-type port (female).
3. Plug the RJ-45 connector, at one end of the CAT 5 cable (not supplied), into the RJ-45 port of the DB15-to-RJ45 adapter located at the ProST.
4. Plug the RJ-45 connector, at the other end of the CAT 5 cable, into the RJ-45 port of the DB15-to-RJ45 adapter located at the SDA-4S.

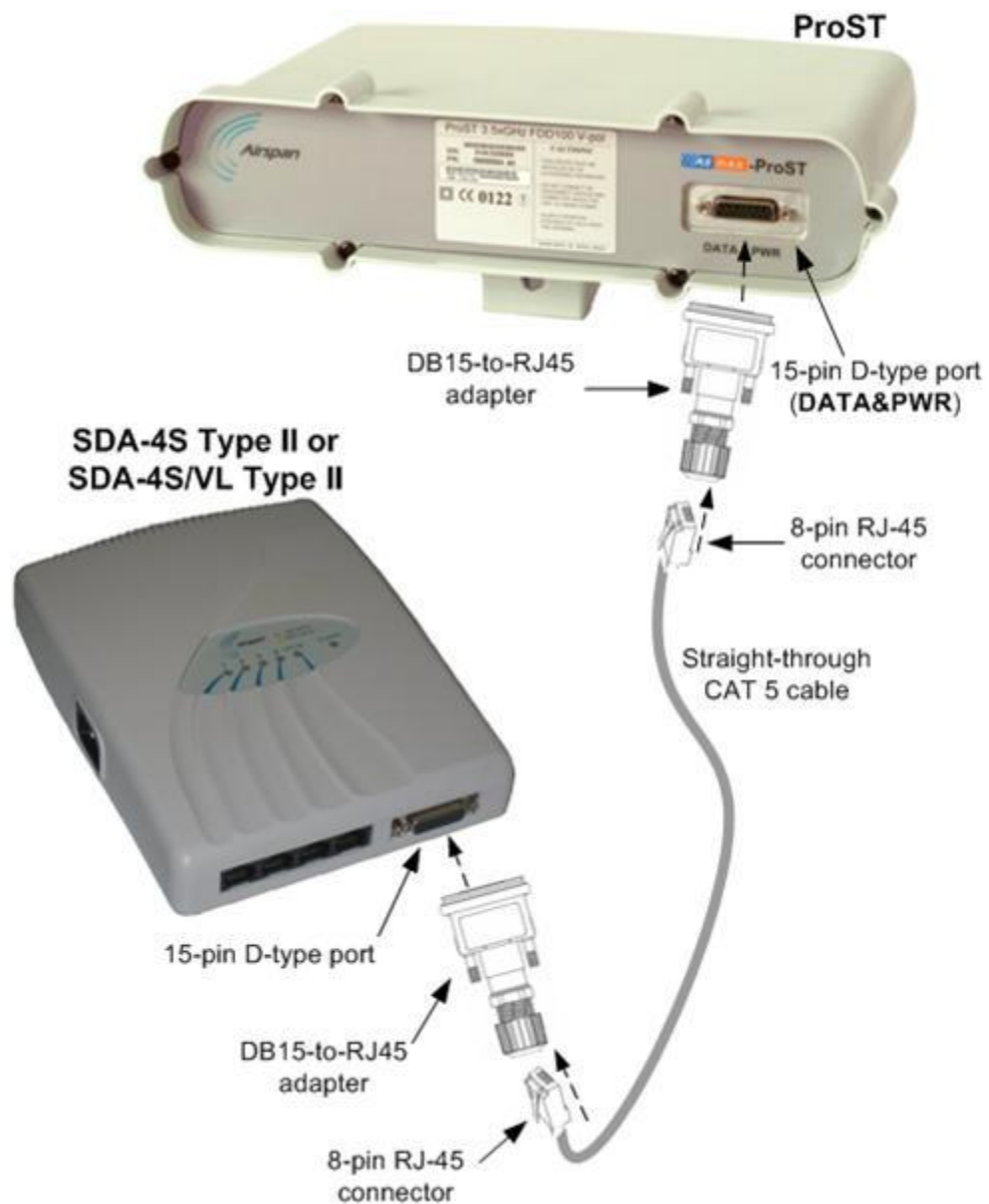

CONNECTING PROST TO A COMPUTER

The ProST typically interfaces with the subscriber's network/computer using the indoor SDA-1 Type II adapter to which the subscriber's PC connects. This adapter provides one 100BaseT interface. However, optional IDU adapters (SDA-4S Type II or SDA-4S/VL Type II) are offered that provide four (10/100BaseT) LAN ports for interfacing with the subscriber's LAN network.



Warning: Only subscriber terminal equipment (e.g. computer modem port) that is designed for full compliance with TNV-1 telecommunication network connectivity can be connected to the SDA-1. Warranty of Airspan's equipment shall be made void if the SDA-1 is connected to a computer that is not compliant with TNV-1.

Using SDA-1 Type II

The SDA-1 Type II provides a single 100BaseT interface with the subscriber's LAN network.

The cable setup for ProST-to-LAN connectivity is as follows:

- ❑ **Cable:** Straight-through CAT 5 Ethernet cable
- ❑ **Connectors:** 8-pin RJ-45
- ❑ **Connector pinouts:**

Pin	Function	
1	Tx+	
2	Tx-	
3	Rx+	
6	Rx-	

Once you have [connected the ProST to the SDA-1](#), you can connect the ProST to the subscriber's computer, as described below.

To connect the ProST to the subscriber's network/PC (via SDA-1):

1. Plug the supplied Category 5 Ethernet cable into the SDA-1's RJ-45 port labeled **LAN/PC**.
2. Plug the loose end of the Category 5 Ethernet cable into the computer's LAN port.

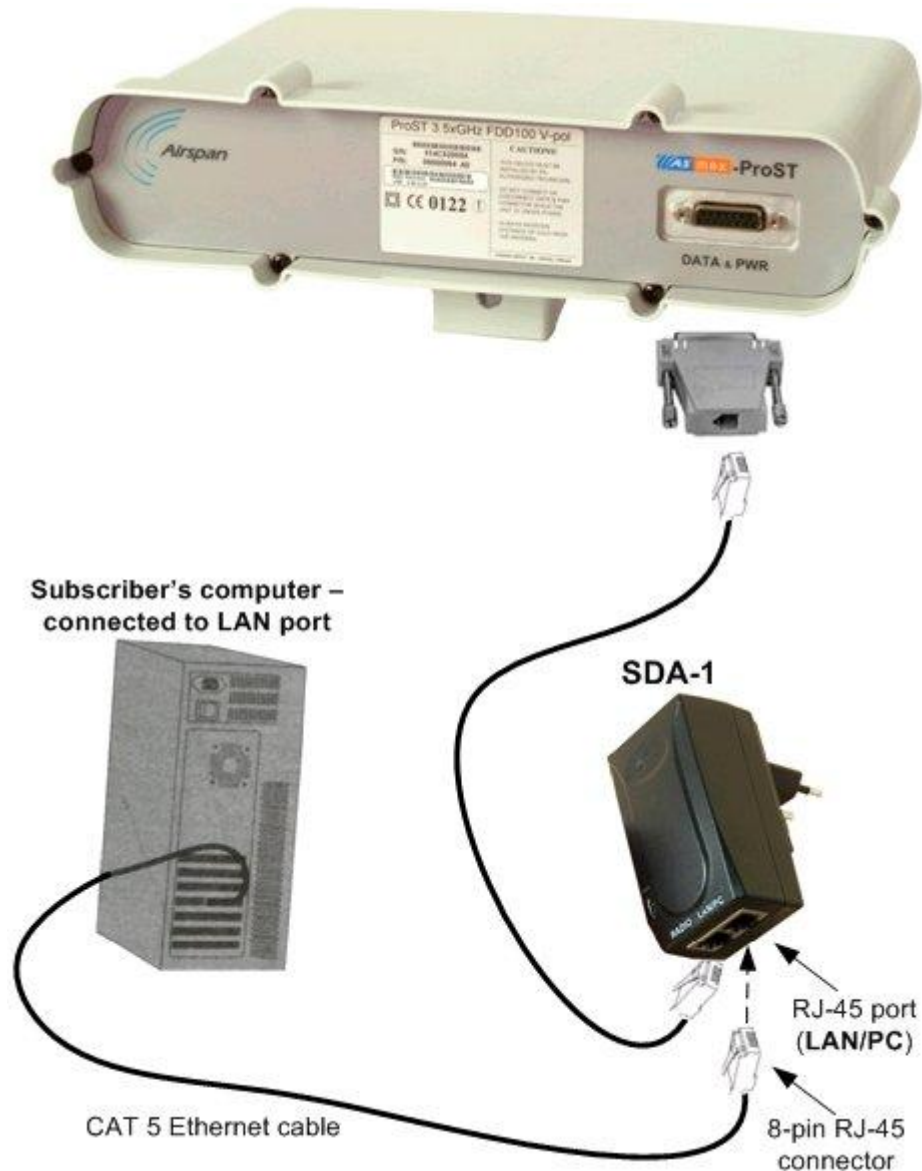

Using the SDA-4S Type II or SDA-4S/VL Type II

The SDA-4S Type II or SDA-4S/VL Type II adapters (referred hereafter as SDA-4S) provide one four RJ-45 (10/100BaseT) ports for interfacing with the subscriber's LAN network. The difference between these two adapters is that the SDA-4S/VL supports VLAN functionality at the ports.

The ports of the SDA-4S models support Auto Negotiation, allowing automatic configuration for the highest possible speed link (10BaseT or 100BaseT), and Full Duplex or Half Duplex mode. In other words, the speed of the connected device (e.g. PC) determines the speed at which packets are transmitted through the specific port. For example, if the device to which the port is connected is running at 100 Mbps, the port connection will transmit packets at 100 Mbps. Conversely, if the device to which the port is connected is running at 10 Mbps, the port connection will transmit packets at 10 Mbps.

In addition, the SDA-4S ports support MDI/MDI-X automatic crossover, allowing connection to straight-through or crossover CAT-5 cables. Therefore, these ports can be connected to either a hub (i.e. using crossover cables) or a PC (i.e. using straight-through cables).

The cable setup for SDA-4S LAN connectivity is as follows:

- ❑ **Cable:** Straight-through (e.g. when connecting to PC) or crossover (i.e. when connecting to a hub) CAT 5 Ethernet cable
- ❑ **Connectors:** 8-pin RJ-45 at both ends
- ❑ **Connector pinouts:**

- o Straight-through cable (e.g. connecting to a PC)

Pin	Function	8-Pin RJ-45
1	Tx+	
2	Tx-	
3	Rx+	
6	Rx-	

- o Crossover cable (e.g. connecting to a hub)

Pin	Function	Pin	Function	8-Pin RJ-45
1	Rx+	3	Tx+	
2	Rx-	6	Tx-	
3	Tx+	1	Rx+	
6	Tx-	2	Rx-	

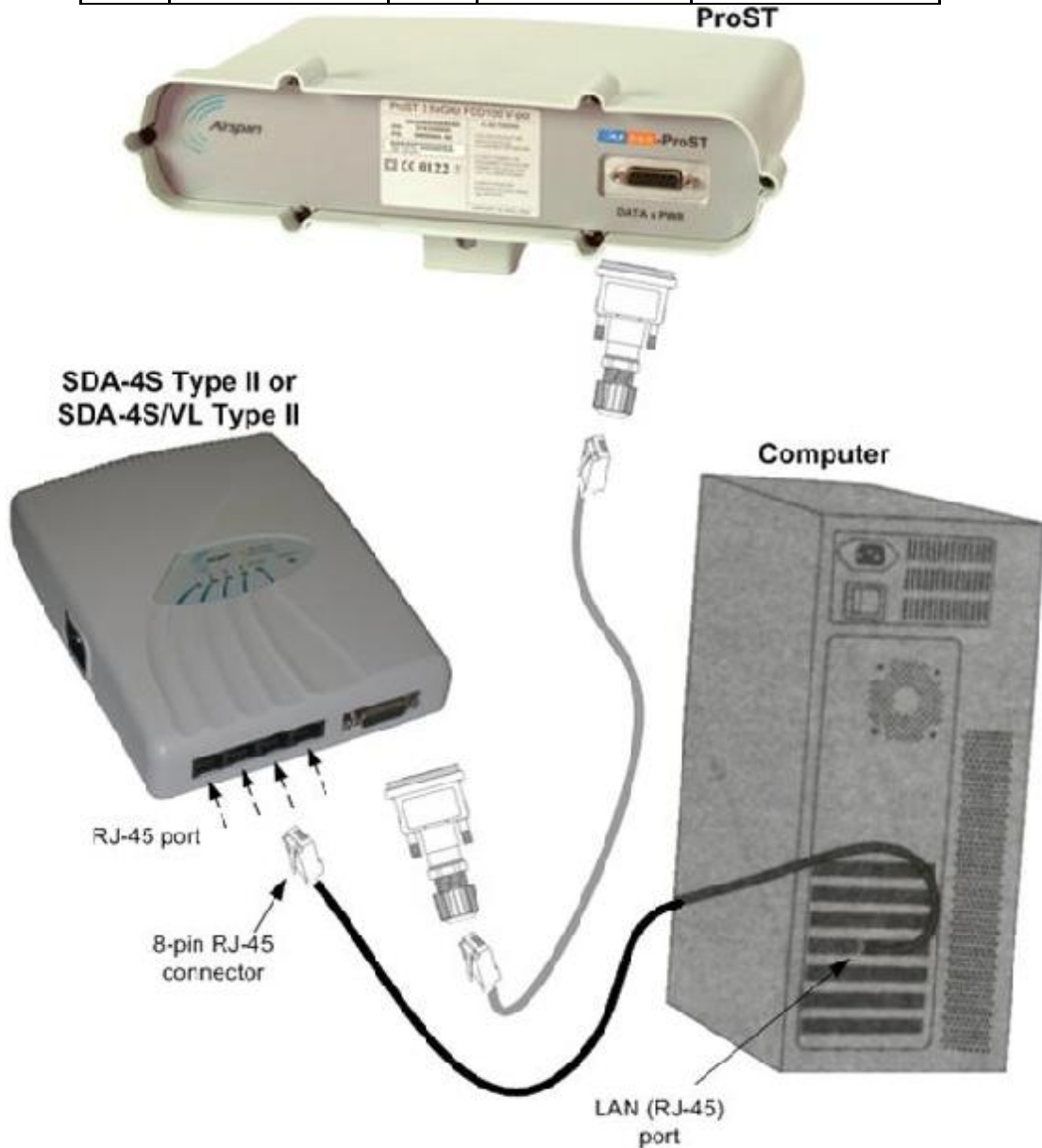

CONNECTING POWER

ProST is a DC-powered device (10 – 52 VDC; 15W max. assuming up to 100-m cable length between ProST and power source) that can be powered from one of the following power sources:

- ❑ DC power connected directly to a 48 VDC (0.5 A) DC power unit
- ❑ AC power using an AC/DC power adapter connected to a standard electrical wall outlet (110/240 VAC)



Warning: Only subscriber terminal equipment (e.g. computer modem port) that is designed for full compliance with TNV-1 telecommunication network can be connected to the SDA-1. Warranty of Airspan's equipment shall be made void if the SDA-1 is connected to a computer that is not compliant with TNV-1.



Note: ProST provides a built-in lightning surge protection, complying to Surge Immunity standard EN 61000-4-5.

DC Power Source

ProST can be connected directly to a DC power supply unit that supplies 10 – 52 VDC. The cable setup is supported by a splitter cable. One end of the splitter cable connects to the ProST (using the RJ45-to-DB15 adapter or connecting directly to the 15-pin D-type). The other end of the cable splits into two wire groups: one for the subscriber's Ethernet interface (four wires) and the other for the DC power source interface (two wires).



Warning: The ProST should be powered by a safety approved limited DC power source with maximum current of 1 A.

The figure below displays the ProST power supply cable setup from a DC power source.

AC Power Source

ProST can be powered from an AC power source by implementing the SDA-1, which is plugged into a standard 110/240 VAC electrical wall outlet. In addition, the SDA-1 allows easy plug prongs replacement to suit geographical location of electrical wall sockets (e.g. American vs. European). The optional IDU adapters (SDA-4S Type II and SDA-4S/VL Type II) also power ProST from the subscriber's AC electrical wall outlet. The difference between the SDA-1 and SDA-4S Type II adapters is the method of connectivity to the power outlet, as discussed in the subsections below.

Airspan can also provide lightning and surge protection for the SDA-1 to protect the data and power interfaces from electrical surges caused when lightning strikes the ODU/IDU Cat 5 cable.

Using SDA-1 Type II

The SDA-1 Type II is plugged directly into a standard electrical wall outlet ((110/240 VAC). The SDA-1 Type II also allows easy plug prongs replacement to suit the electrical wall socket (e.g. American vs. European type) of the geographical location in which the ProST is being installed.

The AC power cabling consists of the following stages:

- ❑ [Changing SDA-1 Type II plug prongs](#)
- ❑ [Plugging SDA-1 into wall outlet](#)

Changing SDA-1 Plug Prongs

The SDA-1 allows you to attach plug prongs that suit the electrical wall socket of the country in which you are installing the equipment. Therefore, before plugging the SDA-1 into the electrical outlet, ensure that the correct prongs are attached to the SDA-1.

To change the SDA-1 plug prongs:

1. On the rear of the SDA-1, slide the locking switch to OPEN.
2. Remove the prongs by sliding the prongs in the direction away from the switch.
3. Insert the desired prongs by aligning the prongs with the SDA-1's prong groove, and then sliding the prongs onto the SDA-1 until it reaches the end of the groove. (See Figure below.)
4. Lock the prongs in place by moving the switch to LOCK.



Plugging the SDA-1 into an Electrical Wall Outlet

Once you have attached the suitable plug prongs onto the SDA-1, you can plug it into a standard 110/240 VAC electrical wall outlet.

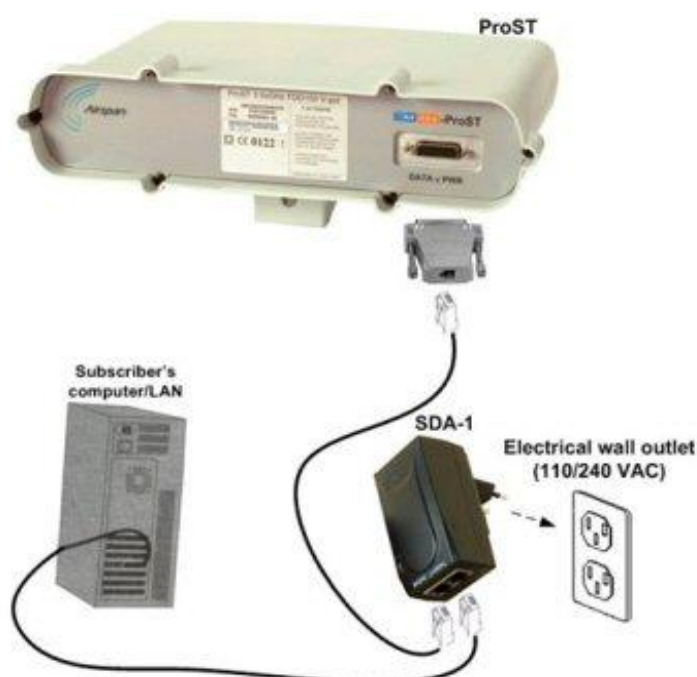

Verify that your SDA-1 is on and receiving power by checking that the green LED light (labeled POWER) on the SDA-1's front panel is lit. If it is not, see Appendix C, "Troubleshooting".

Using SDA-4S Type II and SDA-4S/VL Type II

The SDA-4S adapters are plugged into a standard electrical wall outlet (110/240 VAC) using an AC power cord.

The cable setup between the SDA-4S and power outlet includes the following:

- ▶ **Connector:** AC IEC 60320 type (female)
- ▶ **Plug:** "A" Continental Europe
- ▶ **Cable:** 3x1.20 mm, 10A / 250 VAC (maximum length is 180 cm)

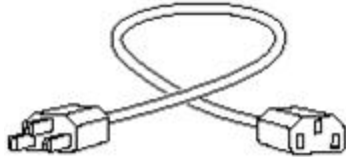

To connect the SDA-4S to the AC power supply:

1. Connect the power plug female, at the end of the AC power chord, into the AC power socket located on the left panel of the SDA-4S.
2. Plug the power plug male, at the other end of the AC power chord, into the AC power outlet (110-240 VAC).
3. Verify that the power is received by the SDA-4S by checking that the **POWER** LED light is on.

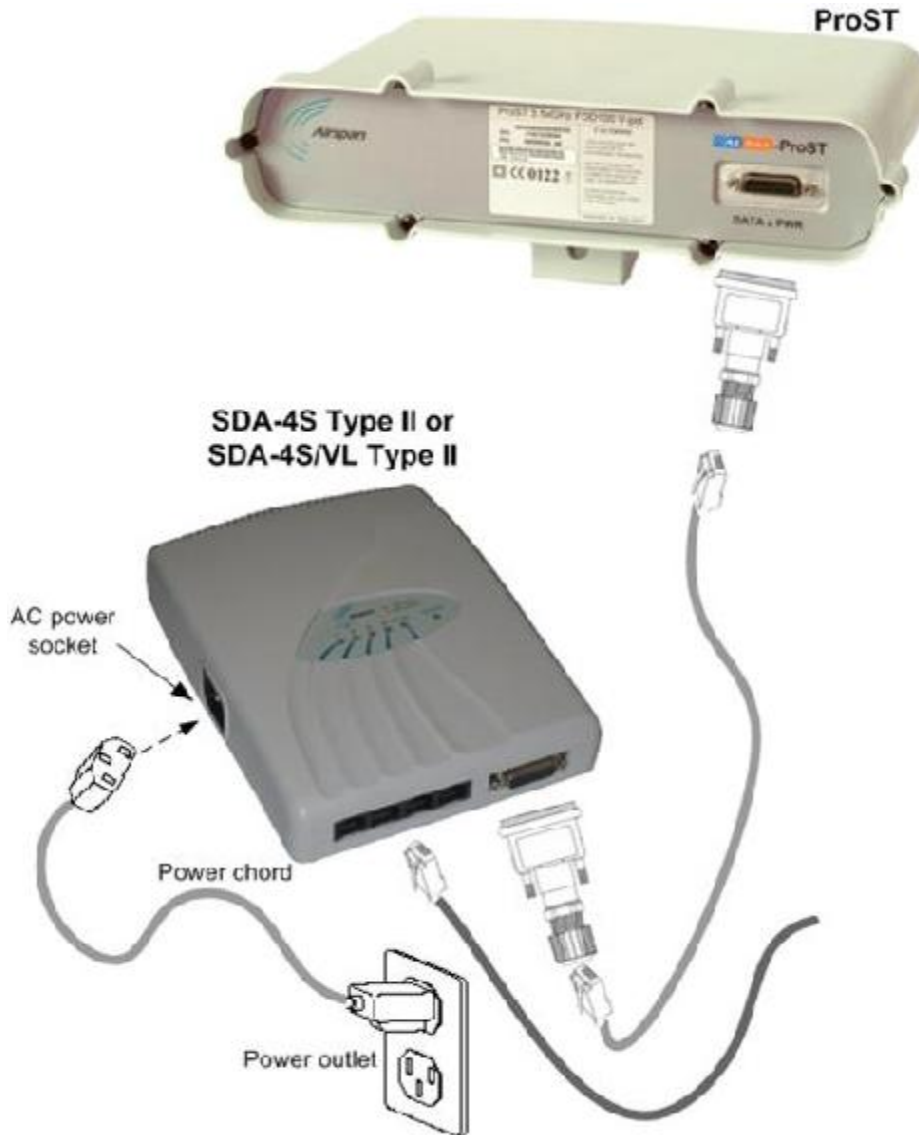

Connecting the Lightning and Surge Protector

The third-party (PolyPhaser) lightning and surge protector for the SDA-1 is implemented in the following deployment scenarios:

- ▣ IDU/ODU cable connectivity of 40 meters or more (mandatory)
- ▣ Deployment of ProST in geographical areas that often experience severe lightning storms

The lightning and surge protector protects the CAT 5's six used wires (two -48 VDC wires and four Ethernet Tx and Rx wires) from any electrical surge due to a lightning strike.

The protector is installed outdoors on the CAT 5 cable that connects between the ProST and SDA-1. In other words, two CAT 5 cables are required: one for the protector-to-ProST connection and the other for the protector-to-SDA-1 connection.



Warning: Do not install the lightning and surge protector during adverse weather conditions when the threat of lightning strike is possible.

To install the protector:

1. Connect the protector in the direction according to the labels. The end labeled SURGE accepts the cable from the ProST; the end labeled PROTECTED accepts the cable from the SDA-1.

2. Feed the CAT 5 cable through the grommet (for each side). If the RJ-45 connector is already crimped to the other end, ensure that you have fed the cable through the gland nut beforehand. The gland nut secures the cable to the grommet.
3. Strip about 0.25" (6.35 mm) of the cable sheath and expose about 0.03" (0.8 mm) of the strands/wires.
4. Secure the wires to the protector's terminal block using the two spot ties. Each side of the data and DC assembly has + or – markings to ensure lines entering (surge side) match lines exiting (protected side).

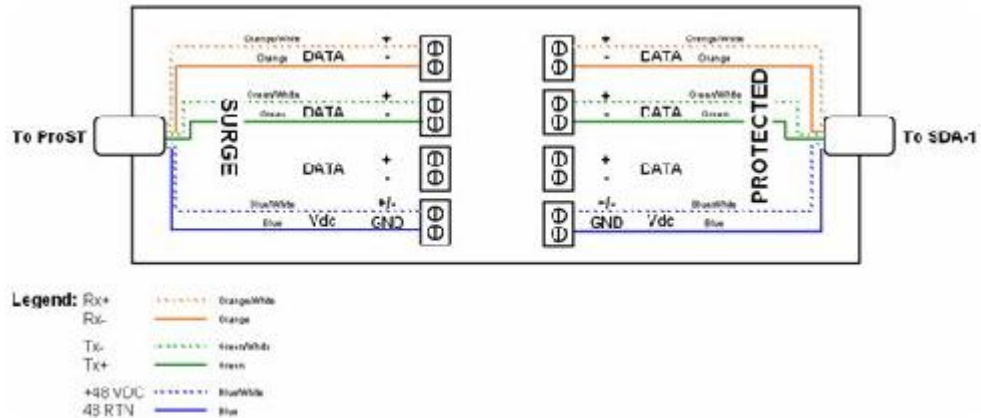

5. Mount and ground the protector outdoors with the provided 2 x 8-32 screws according to the fixing template illustrated in Figure 5 5 (showing distances between centers of the two mounting holes). The unit may be mounted/grounded on a nearby plate or bulkhead panel that is bonded to an earth-ground system.

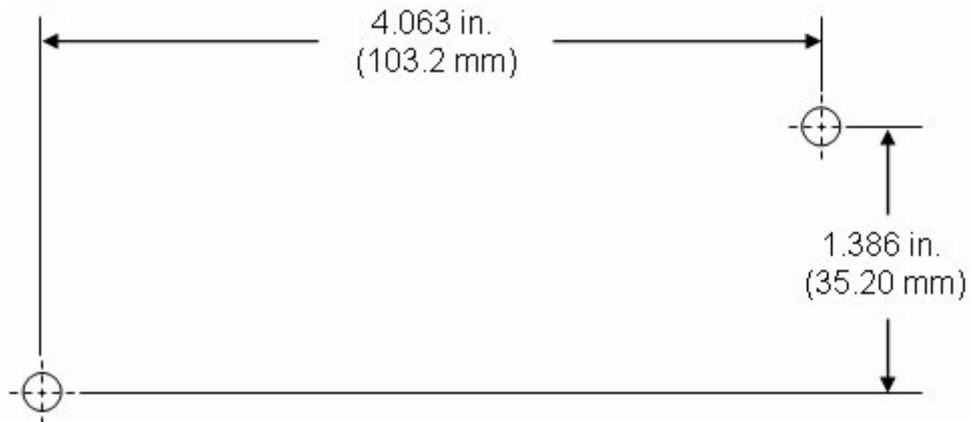

6. Attach the protector's lid by using the four M4 x 20-mm screws. Ensure that the neoprene gasket on the lid is not loose or out of the groove.
7. Secure the CAT 5 cable to the grommet by fastening the gland nut.

Note: The protector unit must be grounded to a low-impedance (low R and low L) ground system in order for it to operate properly.

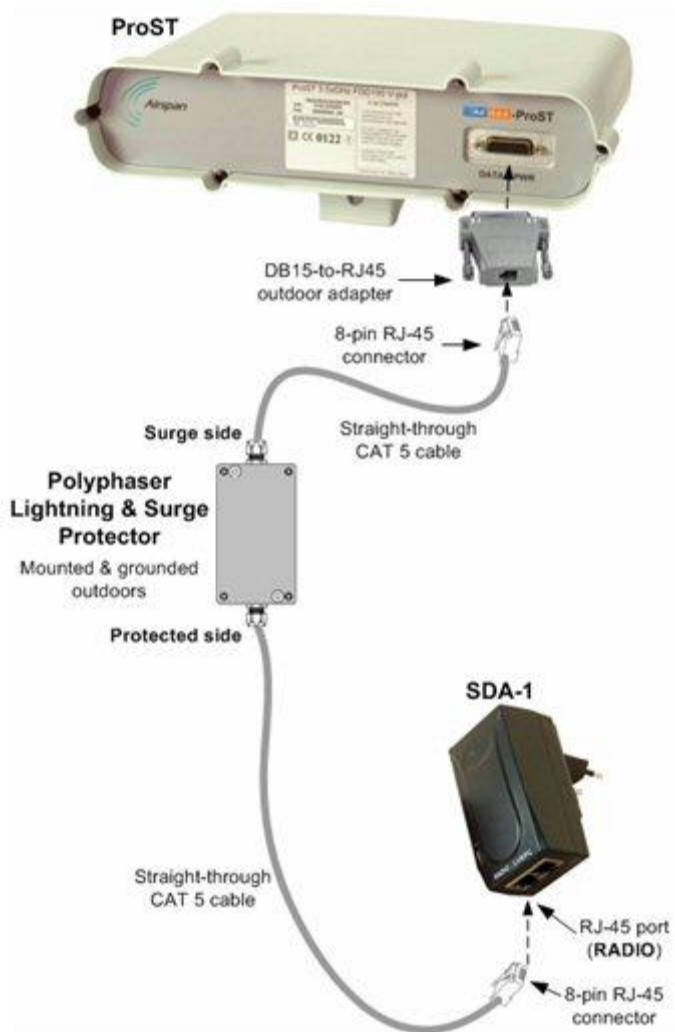

SPECIFICATIONS

This section includes the following specifications:

- ▣ [ProST](#)
- ▣ [SDA-1 Type II adapter](#)
- ▣ [SDA-4S Type II and SDA-4S/VL TypeII](#)
- ▣ [Lightning and Surge protector](#)

ProST Specifications

The ProST's specifications are listed in the table below:

Category	Parameter		Value																							
Radio Technology	WiMAX	Frequency band	4.9 to 5.0 GHz																							
		Duplex method	Time Division Duplexing (TDD)																							
		Channel size	5 or 10 MHz																							
		Transmit (Tx) power	up to 17 dBm																							
		Antenna type	Integrated WiMAX antenna (interfaces with base station): flat-panel with 13 dBi gain																							
		Modulation method	BPSK, QPSK, 16QAM and 64QAM																							
	Receiver (Rx) sensitivity (for BW of 3.5 MHz)	<table border="1"> <thead> <tr> <th>Mode</th> <th>5 MHz</th> <th>10 MHz</th> </tr> </thead> <tbody> <tr> <td>3/4 64QAM:</td> <td>- 80.5 dBm</td> <td>- 77.4 dBm</td> </tr> <tr> <td>2/3 64QAM:</td> <td>- 82.0 dBm</td> <td>- 78.9 dBm</td> </tr> <tr> <td>3/4 16QAM:</td> <td>- 86.2 dBm</td> <td>- 83.1 dBm</td> </tr> <tr> <td>1/2 16QAM:</td> <td>- 89.5 dBm</td> <td>- 86.4 dBm</td> </tr> <tr> <td>3/4 QPSK:</td> <td>- 92.5 dBm</td> <td>- 89.4 dBm</td> </tr> <tr> <td>1/2 QPSK:</td> <td>- 95.0 dBm</td> <td>- 91.9 dBm</td> </tr> <tr> <td>1/2 BPSK:</td> <td>- 97.5 dBm</td> <td>- 94.4 dBm</td> </tr> </tbody> </table>		Mode	5 MHz	10 MHz	3/4 64QAM:	- 80.5 dBm	- 77.4 dBm	2/3 64QAM:	- 82.0 dBm	- 78.9 dBm	3/4 16QAM:	- 86.2 dBm	- 83.1 dBm	1/2 16QAM:	- 89.5 dBm	- 86.4 dBm	3/4 QPSK:	- 92.5 dBm	- 89.4 dBm	1/2 QPSK:	- 95.0 dBm	- 91.9 dBm	1/2 BPSK:	- 97.5 dBm
Mode	5 MHz	10 MHz																								
3/4 64QAM:	- 80.5 dBm	- 77.4 dBm																								
2/3 64QAM:	- 82.0 dBm	- 78.9 dBm																								
3/4 16QAM:	- 86.2 dBm	- 83.1 dBm																								
1/2 16QAM:	- 89.5 dBm	- 86.4 dBm																								
3/4 QPSK:	- 92.5 dBm	- 89.4 dBm																								
1/2 QPSK:	- 95.0 dBm	- 91.9 dBm																								
1/2 BPSK:	- 97.5 dBm	- 94.4 dBm																								
Standards Compliance	WiMAX	Radio	<ul style="list-style-type: none"> ▣ WiMAX Forum Certified™ for IEEE 802.16-2004 ▣ TELEC 																							

			<ul style="list-style-type: none"> ▶ EN 300 328 2.4 GHz ▶ Part 15 15.247- 2.4 GHz
		Safety	EN/IEC/UL 60950
		Environmental	<ul style="list-style-type: none"> ▶ EN 300 019-2-2 ▶ EN 300 019-2-4
Networking	WiMAX	Protocols	Transparent Bridging
		QoS	<ul style="list-style-type: none"> ▶ IP type of service ▶ Protocol ▶ IP source address ▶ IP destination address ▶ Protocol source port ▶ Protocol destination port ▶ Ethernet destination MAC address ▶ Ethernet source MAC address ▶ Ethertype/IEEE 802.2 SAP ▶ IEEE 802.1D User Priority ▶ IEEE 802.1Q VLAN ID
		Default IP address	10.0.0.1
Management	WiMAX	Remote/local	<ul style="list-style-type: none"> ▶ SNMP based (standard and private MIBs): v.1 and v.2 ▶ Web (HTTP) based: HTTP1.0 (RFC 1945) and HTML (RFC1866) and base64 algorithm. Based on secure access (SSL and VPN)
		Software upgrade	Local and remote: TFTP based; Web based; SNMP based
		Management tools	GUI based for SNMP- and Web-based management
Environmental Conditions	WiMAX	Operating temperature	-40°C to +55°C (-40°F to 131°F)
		Operating humidity	+55°C (131°F), RH=90% to 100%
Mechanical and Electrical	WiMAX	Interfaces	<ul style="list-style-type: none"> ▶ Power and management: 15-pin D-type port
		Power requirements	<ul style="list-style-type: none"> ▶ Voltage: 48 VDC ▶ Power consumption: 24W
		Dimensions	<ul style="list-style-type: none"> ▶ Without antenna: 223 x 311 x 105 mm (8.78 x 12.24 x 4.13 inches) ▶ With antenna: 335.5 x 311 x 105 mm (13.2 x 12.24 x 4.13 inches)
		Weight	<ul style="list-style-type: none"> ▶ 1.97 kg

SDA-1 Type II Specifications

The SDA-1's specifications are listed in the table below:

Category	Parameter	Value
Interfaces	Network	Two 10/100BaseT (for interfacing with ProST radio and subscriber's PC/LAN)
	Mechanical	Two 8-pin RJ-45 ports (for 10/100BaseT interface with ProST radio and subscriber's PC/LAN)
Standards compliance	Safety	UL/CUL UL60950, TUV EN60950, CB BN55022
	EMI/RFI	VDE and FCC limit B
Environmental	Operating temperature	0 to +40°C
	Storage temperature	-20 to +85°C
	Humidity	5 to 96% RH non-condensing
Power	Requirements	110/240 VAC, 50/60 Hz (standard electrical wall outlet)
	Output	10 - 52 VDC (15W max.) to ProST
	Mechanical	Interchangeable plug prongs (to suit country of installation)
Physical	Dimensions	86 x 46 x 38.5 mm (3.39 x 1.81 x 1.52 inches)
	Weight	250 g

SDA-4S Type II and SDA-4S/VL Type II Specifications

The SDA-4S Type II and SDA-4S/VL Type II (SDA-4S) specifications are listed in the table below:

Category	Parameter	Value
Interfaces	Networking	<ul style="list-style-type: none"> ▶ 4 x 10/100BaseT interface with subscriber's LAN (ports support Auto Negotiation and MDI/MDI-X automatic crossover detection) ▶ 1 x 10/100BaseT interface with ProST ▶ VLAN per LAN (RJ-45) port (Note: only for SDA-4S/VL Type II)
	Mechanical	<ul style="list-style-type: none"> ▶ 4 x 8-pin RJ-45 ports (10/100BaseT interface with subscriber's LAN) ▶ 1 x 15-pin D-type female port (10/100BaseT interface with

		ProST)  AC power socket
Standards compliance	Safety	UL/CUL UL60950, TUV EN60950, CB BN55022
	EMI/RFI	VDE and FCC limit B
Environmental	Operating temperature	0 to +40°C
	Storage temperature	-20 to +85°C
	Humidity	5 to 96% RH non-condensing
Power	Requirements	110/240 VAC, 50/60 Hz (standard electrical wall outlet)
	Output	-48 VDC nominal
	Mechanical	AC power cord plugged into AC socket
Physical dimensions	Dimensions	200 x 150 x 40 mm (7.87 x 5.9 x 1.57 inches)
	Weight	0.577 kg

Lightning/Surge Protector Specifications

The PolyPhaser lightning and surge protector specifications are listed in the table below:

Parameter		Value				
Connections:		# 16 - 28 AWG				
Temperature:		-40° to +65° C storage; -40° to +50° C operating				
Vibration:		1 G @ 5 Hz to 100 Hz				
Environmental:		• BELLCORE #TA-NWT-000487				
		• Procedure 4.11				
		• Wind Driven (70 MPH) Rain				
		• Intrusion Test				
Surge:		BELLCORE 1089, 10/1000 uSec @ 100 A				
Agency Approval:		UL497B - Listed				
Modules:	IX-H	Application	Turn On	Series Resistance	Capacitance	Current
		(up to 100Mbps) CAT5 Compatible, UTP, STP	+ 8 Vdc, Common and Differential Mode	1 Ohm Typical	Common Mode: 15 pF Typical; Differential Mode: 30 pF Typical	--
	IX-M	(up to 25Mbps) RS 232	+/- 30 Vdc	1 Ohm Typical	Differential Mode: 100 pF Typical; Differential Mode: 100 pF Typical;	--

Specifications

	IX-DC24 or DC48	(24 or 48Vdc) Power Supply, dc voltage	+/- 32, +/- 53 Vdc	< 0.02 Ohms	--	2.0 Adc
--	--------------------------------	---	-----------------------	----------------	----	---------

GENERAL CONTACT INFORMATION

UK Office for sales and general enquiries

Airspan Communications Ltd
Cambridge House
Oxford Road
Uxbridge
Middlesex
UB8 1UN

Call +44 (0) 1895 467100

Fax +44 (0) 1895 467101

email sales@airspan.com

Internet: Airspan.com

Customer Service Help-Desk for customer service emergency

Airspan Communications Limited
Cambridge House
Oxford Road
Uxbridge
Middlesex
UB8 1UN

Int. Tel: +44 (0) 1895 467 467

Int. Fax: +44 (0) 1895 467 472

E-mail: Support@Airspan.com

COPYRIGHT INFORMATION

1. ©Airspan Networks Inc 2006
2. The information in this document is proprietary to Airspan Networks Inc. This document may not in whole or in part be copied, reproduced, or reduced to any medium without prior consent, in writing, from Airspan Networks Inc.
3. This manual is subject to revision.
4. All rights reserved.
5. Right of modification reserved.
6. This manual is supplied without liability for errors or omissions.
7. No part of this manual may be reproduced or used except as authorised by contract or other written permission.
8. This equipment is conditioned by the requirement that no modifications are made to the equipment unless the changes or modifications are expressly approved by the Airspan Networks Inc.
9. Prerequisite skills: Personnel installing, commissioning, and maintaining the Airspan products must have a basic knowledge of telephony and radio communications, and have experience in installing, commissioning and maintaining telecommunications products. Airspan provides a range of comprehensive training courses specifically aimed at providing operators/users of Airspan products with the prerequisite skills to install, commission and or maintain the product. The courses are tailored to provide the level of training required by the operator/user.
10. AS.MAX, EasyST, ProST, MicroMAX, MacroMAX, HiperMAX and Netspan are brands of Airspan Networks Inc

GLOSSARY

#

802.1X: IEEE standard for network access control to LAN users by allowing or preventing access determined by authentication.

A

AES: Advanced Encryption Standard. A block cipher adopted as an encryption standard by the US government. AES has a fixed block size of 128 bits and a key size of 128, 192 or 256 bits.

AP: Access Point (i.e. ProST-WiFi's WiFi interface)

B

BPSK: Binary Phase Shift Keying

BS: Base Station (for example, WiMAX BS)

BWA: Broadband Wireless Access

C

CID: Connection Identifier Number

CPE: Customer Premises Equipment (interchangeable with ST)

D

dB: Decibel

dBm: Power ratio in dB (decibel) of the measured power referenced to one milliwatt

DL: Downlink

F

FDD: Frequency division duplex

FEC: Forward Error Correction

FTP: File Transfer Protocol

G

GHz: Gigahertz. One GHz represents 1 billion cycles per second

H

HFDD: Half duplex FDD

Hz: Hertz

I

IAD: Integrated access device

ICMP: Internet Control Message Protocol

IP: Internet Protocol

ISP: Internet Service Provider

L

L2PT: Layer 2 Protocol Tunneling

LAN: Local-Area Network

M

MAC: The next layer up from the PHY, known as the media access controller

Mbit/s: Megabits per second

MHz: Megahertz (one million cycles per second)

MIB: Management Information Base

N

NAS: Network Access Server

NLOS: Non Line of Sight radio propagation path

O

ODU: Out door unit associated with a ST

OFDM: Orthogonal Frequency Division Multiplexing

P

PMKSA: Pairwise Master Key Security Association

PPPoE: Point-to-Point over Ethernet

PPTP: Point-to-Point Tunneling Protocol

Q

QAM: Quadrature Amplitude Modulation

QoS: Quality of Service, which is used to specify level of data throughput

QPSK: Quadrature Phase Shift Keying

R

RADIUS: Remote Authentication Dial-In User Service. An authentication and accounting system used by many Internet Service Providers (ISPs). When you dial in to the ISP you must enter your username and password. This information is passed to a RADIUS server, which checks that the information is correct, and then authorizes access to the ISP system.

RF: Radio Frequency

Rx: Receive

S

SF: Service Flow

SME: Small and Medium-sized Enterprise

SNMP: Simple Network Management Protocol

SNR: Signal-to-Noise Ratio

SSIS: Service Set Identifier

ST: Subscriber Terminal (interchangeable with CPE or SS)

T

TCP: Transmission Control Protocol

TDMA: Time Division Multiple Access. Technology for delivering digital wireless service using time-division multiplexing (TDM)

TKIP: Temporal Key Integrity Protocol. Security protocol used in Wi-Fi Protected Access (WPA). TKIP, like WEP, uses a key scheme based on RC4, but unlike WEP, TKIP provides per-packet key mixing, a message integrity check and a re-keying mechanism. TKIP ensures that every data packet is sent with its own unique encryption key.

TNV: Telecommunications Network Voltage

Tx: Transmit

U

UDP: User Datagram Protocol

UGS: Unsolicited Grant Service. Used to provide fixed bandwidth slots on the uplink for an ST to transmit data at regular intervals. The bandwidth should be used by the UGS SF, however the final decision of which SF (if any) uses the bandwidth slot is made by the ST.

V

VoIP: Voice over Internet Protocol

W

WAN: Wireless Area Network

WiFi: Wireless Fidelity. Used generically when referring to any type of 802.11 network, whether 802.11g, 802.11b, etc.

WiMAX: WiMAX is a wireless industry coalition whose members are organized to advance IEEE 802.16 standards for broadband wireless access (BWA) networks.

WPA: Wi-Fi Protected Access. Used for WiFi networks to correct deficiencies in the older Wired Equivalent Privacy (WEP) security standard.

WPA2: Wi-Fi Protected Access 2.

INDEX

A

Architecture 6

B

Bandwidth speeds 6

Benefits 6

C

Components 6

F

Features 6

M

Modulation technologies6

O

Operating frequency band6

P

Physical Dimensions 14

Ports

 Description 14

T

Theory of operation6



How to find out
more
about
Airspan products
and solutions

For more information about Airspan, its products and solutions, please visit our Web site:

www.airspan.com

Or write to us at one of the addresses below.

We will be delighted to send you additional information on any of our products and their applications around the world.

Airspan has offices in the following countries:

Europe

Czech Republic
Poland
Russia
United Kingdom

Africa

South Africa

Americas

United States

Asia Pacific

Australia
China
Indonesia
Japan
New Zealand



**Worldwide Headquarters:
Airspan Networks Inc.**
777 Yamato Road, Suite 105
Boca Raton, Florida 33431-4408
USA

Tel: +1 561 893 8670
Fax: +1 561 893 8671

**Main Operations:
Airspan Communications Ltd.**
Cambridge House, Oxford Road,
Uxbridge, Middlesex UB8 1UN
UK

Tel: +44 (0) 1895 467 100