



UGD-D00229 Rev B

**Air4G
Installation Guide**





Copyright

© Copyright by **Airspan Networks Inc.**, 2013. All rights reserved worldwide.

The information contained within this document is proprietary and is subject to all relevant copyright, patent and other laws protecting intellectual property, as well as any specific agreements protecting Airspan Networks Inc. rights in the aforesaid information. Neither this document nor the information contained herein may be published, reproduced or disclosed to third parties, in whole or in part, without the express, prior, written permission of Airspan Networks Inc. In addition, any use of this document or the information contained herein for the purposes other than those for which it is disclosed is strictly forbidden.

Airspan Networks Inc. reserves the right, without prior notice or liability, to make changes in equipment design or specifications.

Information supplied by Airspan Networks Inc. is believed to be accurate and reliable. However, no responsibility is assumed by Airspan Networks Inc. for the use thereof nor for the rights of third parties which may be effected in any way by the use of thereof.

Any representation(s) in this document concerning performance of Airspan Networks Inc. product(s) are for informational purposes only and are not warranties of future performance, either expressed or implied. Airspan Networks Inc. standard limited warranty, stated in its sales contract or order confirmation form, is the only warranty offered by Airspan Networks Inc. in relation thereto.

This document may contain flaws, omissions or typesetting errors; no warranty is granted nor liability assumed in relation thereto unless specifically undertaken in Airspan Networks Inc. sales contract or order confirmation. Information contained herein is periodically updated and changes will be incorporated into subsequent editions. If you have encountered an error, please notify Airspan Networks Inc. All specifications are subject to change without prior notice.

Product performance figures quoted within this document are indicative and for information purposes only.



Table of Contents

Copyright	2
Table of Contents	3
Summary of Figures	6
Summary of Tables	8
Warnings and Cautions	9
Human Exposure to Radio Frequencies	9
Radio Interference	9
Avoiding Radio Interference	9
Modifications	9
General	9
Safety	9
Warning Symbols	10
Service Information	10
UL Information	10
Lightning Protection	10
DECLARATION OF CONFORMITY	12
FCC Notice	13
Federal Communication Commission Notice	13
GPS Compliance	13
Maximum Output TX Power	14
Power Consumption	15
Antenna Types	15
Air4G Antenna Usage	16
1 About this Guide	18
1.1 Purpose	18
1.2 Intended Audience	18
1.3 Conventions	18
1.4 Referenced Documentation	18
1.5 Organization of this Guide	18
2 Introduction	20
2.1 Air4G	20
2.1.1 Deployment Description	20
3 Getting Started	23
3.1 Workflow of Installation	23
3.2 Air4G Installation Checklist	23
4 Verify Prerequisites	24
4.1 Verify Safety Requirements	24
4.1.1 Warning of Hazardous Voltages	24



Air4G Installation Guide

4.2	Verify Installation Requirements.....	25
4.2.1	Verify the Tools.....	25
4.2.2	Verify the Parts and Kits	25
4.2.3	Verify Components	32
5	Install Air4G	36
5.1	Pole mount configuration.....	36
5.2	Wall mount configuration	38
5.2.1	Mounting Examples	40
5.3	Surge Protector Mounting.....	40
5.3.1	Lightning /Surge Protector Installation.....	41
5.4	Air4G Connections.....	43
5.5	Install Air4G Antennas	43
5.5.1	Install Dual Slant Antenna	44
5.5.2	Install Quad Slant Antenna	45
5.5.3	Install Omni Antenna	48
5.6	Optional Mounting Antenna on Air4G.....	48
5.6.1	Variable Tilt Antenna	49
5.7	Cavity Filter Installation.....	50
5.8	External Duplexer Installation.....	50
5.8.1	External Duplexer to Air4G Connection.....	52
5.9	Antenna Connection	52
5.10	GPS Antenna Assembly	53
5.10.1	GPS Antenna Mounting.....	54
5.10.2	Remote Mounting of GPS Antenna	55
5.11	LED Display	56
5.12	Install Junction Box (Optional).....	57
5.12.1	Junction Box Installation	57
6	Connect and Manage Cables	60
6.1	Assemble Ethernet Connector.....	60
7	Set Power System	61
7.1	Power Input - DC	61
8	Initial WEB Configuration.....	62
8.1	Initial configuration.....	62
8.1.1	General Config.....	62
8.1.2	SNMP Agent/Trap Configuration	63
8.1.3	Mgmt IP Config	63
8.1.4	BS Operational State	64
9	Appendix A	66
9.1	Review Job Sheet.....	66



Air4G Installation Guide

9.2	Securing Fiber-optic Cable	66
9.3	Connecting the Fiber-optic Cable	68
10	Appendix C – Glossary of Terms.....	70
11	Appendix D – Installation Checklist	72
12	Appendix E	73
12.1	Revision History	73
12.2	Contact Information	73



Summary of Figures

Figure 1 – Air4G – Daisy Chain configuration	21
Figure 2 – Air4G – Star configuration	21
Figure 3 - Air4G – each sector connected separately	22
Figure 4 – Workflow of Installation	23
Figure 5 - PS – Air4G Table 13 - Air4G wall mount installation parts	29
Figure 6 – Air4G Base Station Unit, Ethernet termination	33
Figure 7 – Air4G Base Station Unit, RF ports	33
Figure 8 - Junction box with pole assembly	34
Figure 9 - External Duplexer with pre-assembled brackets	34
Figure 10 - External Duplexer bottom panel	35
Figure 11 - External Duplexer top panel	35
Figure 12 – Pole Mounted Air4G Assembly	36
Figure 13 - pole mounting bracket (2 required)	36
Figure 14 - pole bracket wrap	37
Figure 15 - position brackets on pole	37
Figure 16 - spacing the brackets	37
Figure 17 – Pole Mounted Air4G	38
Figure 18 - pole bracket for 60 > 120 mm	38
Figure 19 – Wall Mounted Air4G	38
Figure 20 – Wall Mounted Air4G Wall Plate Details	39
Figure 21 - Wall mount	40
Figure 22 - GPS alternative assembly	40
Figure 23 – Air4G Cable for remote assembly of GPS Antenna	41
Figure 24 - Lightning/Surge protector (required)	41
Figure 25 - Surge protector installation	42
Figure 26 - Surge protector cable connections	43
Figure 27 - Air4G connections (bottom)	43
Figure 28 – Air4G External Antenna Configuration	44
Figure 29 - Air4G Antenna Dual Slant Mast Mount Configuration	44
Figure 30 – Air4G Antenna Quad Slant Mast Mount Configuration	45
Figure 31 - Adjustable Mounting Kit, with Snaplock Stainless Steel Bands	46
Figure 32 - Adjustable Mounting Kit, with ‘V’ Blocks	47
Figure 33 - Adjustable Mounting Kit 2, with ‘V’ Blocks	48
Figure 34 - possible Omni antenna array	48
Figure 35 - Variable tilt antenna	49
Figure 36 - Antenna mounted on Air4G	49
Figure 37 - Cavity filter(s) installation	50
Figure 38 - pole mounting stainless steel bands (2 required)	51



Air4G Installation Guide

Figure 39 - fold back band.....	51
Figure 40 - Pole Mounted external Duplexer.....	51
Figure 41 - Duplexer to Air4G connections	52
Figure 42 - Quad port antenna connection – 1.....	53
Figure 43 - Quad port antenna connection – 2.....	53
Figure 44 - GPS cable assembly prior to mounting.....	54
Figure 45 - Attach GPS antenna to RG58 cable	54
Figure 46 - GPS antenna assembled on bracket	55
Figure 47 - Clear sky conditions	55
Figure 48 - minimal distance	55
Figure 49 - GPS Remote mounting	56
Figure 50 - Junction box with mounting brackets assembled	57
Figure 51 - mounting bracket (2 required).....	57
Figure 52 - Air4G assembly with optional junction box	59
Figure 53 – Ethernet connector cable termination	60
Figure 54 – Ethernet environmental connector assembly.....	60
Figure 55 – DC Power connection.....	61
Figure 56 - Power connector – Air4G bottom panel.....	61
Figure 57 – General BS Configuration Initial.....	62
Figure 58 - SNMP Initial Configuration.....	63
Figure 59 - Management IP Configuration	64
Figure 60 - Operational State	65
Figure 61 - Secure fiber-optic cable, place tie.....	67
Figure 62 – Secure fiber-optic cable, pull tie.....	67
Figure 63 – Secure fiber-optic cable, snug tie.....	67
Figure 64 – Secure fiber-optic cable, cut excess tie.....	67
Figure 65 – Secure fiber-optic cable, use excess tie.....	68
Figure 66 – Secure fiber-optic cable, re-use excess tie	68
Figure 67 - fiber-optic connector with dust cover	68
Figure 68 – dust cover removed.....	68
Figure 69 - Fiber-Optic Outdoor Connector Plug (multimode)	69
Figure 70 - screw hand-tight.....	69
Figure 71 - Fiber-optic cable connected.....	69



Summary of Tables

Table 1 - Air4G FCC Maximum Output TX Power	14
Table 2 - Air4G ETSI Maximum Output TX Power	14
Table 3 - Power Consumption	15
Table 4 - 700 MHz Antenna Types -Technical	15
Table 5 - 2.x GHz Antenna Types - Technical	15
Table 6 - 3.x GHz Antenna Types - Technical	15
Table 7 - 5.x GHz Antenna Types - Technical	16
Table 8 - Antenna arrays	16
Table 9 - Air4G installation tools.....	25
Table 10 - Air4G installation parts and kits.....	25
Table 11 - GPS Kit Contents	27
Table 12 - Input Power for Air4G.....	28
Figure 5 - PS – Air4G	
Table 13 - Air4G wall mount installation parts	29
Table 14 - Air4G pole mount installation parts	30
Table 15 - Air4G additional parts and kits	31
Table 16 - Cavity filter (for 2.3 variant only) (U.S.A. – WCS market only)	31
Table 17 - Junction box (optional)	31
Table 18 - External Duplexer (for some FDD variants only)	32
Table 19 - Air4G 3.x physical dimensions	33
Table 20 - Air4G 5.x, 2.x, 1.x, 0808 & 0707 physical dimensions.....	34
Table 21 - External Duplexer variants	35
Table 22 - Parts legend	41
Table 23 - recommended distance	48
Table 24 - Antenna connection.....	53
Table 25 - LED Display.....	56
Table 26 - Cable hole sizes	58
Table 27 - Checklist for Procedure	72



Warnings and Cautions

Human Exposure to Radio Frequencies

The Air4G antennas should be installed and operated from a minimum distance of 2.4 meters (for 5.x, 3.x, 0707, 0808 and 1.x) or 3.4 meters (for 2.x) from your body.

Radio Interference

This Air4G generates, uses, and can radiate radio frequency energy and, if not installed and used in accordance with the instructions, may cause harmful interference to radio communications. However, there is no guarantee that interference will not occur in a particular installation. If this equipment does cause harmful interference to radio or television reception, which can be determined by turning the equipment on and off, the technician is encouraged to try to correct the interference by performing one or more of the following measures:

- Re-orientate or relocate the antenna
- Increase separation between the BSs and/or End Device
- Connect the equipment to an outlet on a circuit different from that to which the power source is connected

Avoiding Radio Interference

Ensure a minimum of 1-meter separation between co-located antennas of Air4G units.

Modifications

Any changes and modifications to this device that are not expressly approved by Airspan Networks may void the user's authority to operate the equipment.

General

- Only qualified personnel should be allowed to install, replace, and service the equipment.
- The device cannot be sold retail, to the general public or by mail order. It must be sold to operators.
- Installation must be controlled.
- Installation must be performed by licensed professionals.
- Installation requires special training. The Air4G radio and antenna should be installed ONLY by experienced installation professionals who are familiar with local building and safety codes and, wherever applicable, are licensed by the appropriate government regulatory authorities. Failure to do so may void Airspan's product warranty and may expose the end user or the service provider to legal and financial liabilities. Airspan and its resellers or distributors are not liable for injury, damage or violation of regulations associated with the installation of outdoor units or antennas.

Safety

1. Read this guide and follow all operating and safety instructions.
2. Keep all product information for future reference.
3. This product is supplied with a grounding power plug. Do not defeat this important safety feature.
4. **Warning:** High voltages exist inside the product - do not remove the lid or base: No user serviceable parts inside.
5. Position the power cord to avoid possible damage; do not overload wall outlets.
6. Do not place this product on or near a direct heat source, and avoid placing objects on the terminal.



Air4G Installation Guide

7. Do not operate this device near water or in a wet location.
8. Use only a damp cloth for cleaning. Do not use liquid or aerosol cleaners. Disconnect the power before cleaning.
9. The units should not be located near power lines or other electrical power circuits.
10. The radio transceiver must be properly grounded to protect against power surges and accumulated static electricity. It is the user's responsibility to install this device in accordance with the local electrical codes.
11. Installation of the Air4G must be contracted to a professional installer.
12. Disconnect Device. The socket outlet should be easily accessible in case you have to disconnect the device.
13. When installed in the final configuration, the product must comply with the applicable Safety Standards and regulatory requirements of the country in which it is installed. If necessary, consult with the appropriate regulatory agencies and inspection authorities to ensure compliance.

Warning Symbols

The following symbols may be encountered during installation or troubleshooting. These warning symbols mean danger. Bodily injury may result if you are not aware of the safety hazards involved in working with electrical equipment and radio transmitters. Familiarize yourself with standard safety practices before continuing.



Electro-Magnetic Radiation



High Voltage

Service Information

Refer all repairs to qualified service personnel. Do not remove the covers or modify any part of this device, as this will void the warranty.

Disconnect the power to this product and return it for service if the following conditions apply:

- a. The terminal does not function after following the operating instructions outlined in this manual.
- b. Liquid has been spilled, a foreign object is inside, or the terminal has been exposed to rain.
- c. The product has been dropped or the housing is damaged.

Locate the serial number of the terminal, antenna, and transceiver and record these on your registration card for future reference. Use the space below to affix serial number stickers. Also record the MAC address, located on the back of the terminal.

UL Information

- The equipment must be properly grounded according with NEC and other local safety code requirements.

- Reminder to all the BWA system installers: Attention to Section 820-40 of the NEC which provides guidelines for proper grounding and, in particular, specifies that the cable ground shall be connected to the grounding system of the building, as close to the point of cable entry as is practical.

Lightning Protection

WARNING: The following notes are general recommendations for the system. The wireless equipment should be installed by a qualified professional installer and must follow local and



Air4G Installation Guide

national codes for electrical grounding and safety. Failure to meet safety requirements and/or use of non-standard practices and procedures could result in personal injury and damage to equipment. A direct lightning strike may cause serious damage even if these guidelines are followed.

All outdoor wireless equipment is susceptible to lightning damage from a direct hit or induced current from a near strike. Lightning protection and grounding practices in local and national electrical codes serve to minimize equipment damage, service outages, and serious injury. Reasons for lightning damage are summarized as:

- Poorly grounded tower/antenna sites that can conduct high lightning strike energy into equipment.
- Lack of properly installed lightning protection equipment that can cause equipment failures from lightning induced currents.

A lightning protection system provides a means by which the energy may enter earth without passing through and damaging parts of a structure. A lightning protection system does not prevent lightning from striking; it provides a means for controlling it and preventing damage by providing a low resistance path for the discharge of energy to travel safely to ground. Improperly grounded connections are also a source of noise that can cause sensitive equipment to malfunction.

A good tower grounding system disperses most of the surge energy from a tower strike away from the building and equipment.

To limit the equipment damage due to a lightning strike, the following practices are recommended for the wireless system:

- Provide direct grounding from the antenna mounting bracket, the radio and antenna and the lightning/surge protectors to the same ground point at the base of the tower or a ground bus on the building. Use the grounding screws on the antenna bracket and the radio and antenna for terminating the ground wires.
- The AC wall outlet ground must be connected to the same grounding system as the BS.



DECLARATION OF CONFORMITY

European Community, Switzerland, Norway, Iceland, and Liechtenstein

Declaration of Conformity with Regard to the R&TTE Directive 1999/5/EC

English:

This equipment is in compliance with the essential requirements and other relevant provisions of Directive 1999/5/EC.

Deutsch:

Dieses Gerät entspricht den grundlegenden Anforderungen und den weiteren entsprechenden Vorgaben der Richtlinie 1999/5/EU.

Dansk:

Dette udstyr er i overensstemmelse med de væsentlige krav og andre relevante bestemmelser i Directiv 1999/5/EF.

Español:

Este equipo cumple con los requisitos esenciales así como con otras disposiciones de la Directive 1999/5/EC.

Greek:

ΜΕ ΤΗΝ ΠΑΡΟΥΣΑ Airspan ΔΗΛΩΝΕΙ ΟΤΙ Ο ΕΞΟΠΛΙΣΜΟΣ ΣΥΜΜΟΡΦΩΝΕΤΑΙ ΠΡΟΣ ΤΙΣ ΟΥΣΙΩΔΕΙΣ ΑΠΑΙΤΗΣΕΙΣ ΚΑΙ ΤΙΣ ΛΟΙΠΕΣ ΣΧΕΤΙΚΕΣ ΔΙΑΤΑΞΕΙΣ ΤΗΣ ΟΔΗΓΙΑΣ 1999/5/ΕΚ.

Français:

Cet appareil est conforme aux exigences essentielles et aux autres dispositions pertinentes de la Directive 1999/5/EC.

Íslenska:

Þessi búnaður samrýmist lögboðnum kröfum og öðrum ákvæðum tilskipunar 1999/5/ESB.

Italiano:

Questo apparato é conforme ai requisiti essenziali ed agli altri principi sanciti dalla Direttiva 1999/5/EC.

Nederlands:

Deze apparatuur voldoet aan de belangrijkste eisen en andere voorzieningen van richtlijn 1999/5/EC.

Norsk:

Dette utstyret er i samsvar med de grunnleggende krav og andre relevante bestemmelser i EU-directiv 1999/5/EC.

Português:

Este equipamento satisfaz os requisitos essenciais e outras provisões da Directiva 1999/5/EC.

Suomalainen:

Tämä laite täyttää direktiivin 1999/5/EY oleelliset vaatimukset ja on siinä asetettujen muidenkin ehtojen mukainen.

Svenska:

Denna utrustning är i överensstämmelse med de väsentliga kraven och andra relevanta bestämmelser i Direktiv 1999/5/EC.

Român:

Acest echipament este în conformitate cu cerințele esențiale și alte prevederi relevante ale Directivei 1999/5/CE.

The Declaration of Conformity related to this product can be obtained from PLM@Airspan.com.



FCC Notice

Federal Communication Commission Notice

This equipment has been tested and found to comply with the limits for a Class A digital device, pursuant to part 15 of the FCC Rules. These limits are designed to provide reasonable protection against harmful interference when the equipment is operated in a commercial environment. This equipment generates, uses, and can radiate radio frequency energy and, if not installed and used in accordance with the instruction manual, may cause harmful interference to radio communications. Operation of this equipment in a residential area is likely to cause harmful interference in which case the user will be required to correct the interference at his/her own expense.

Fixed and base stations transmitting a signal with an emission bandwidth greater than 1 MHz must not exceed an ERP of 1000 watts/MHz and an antenna height of 305 m HAAT, except that antenna heights greater than 305 m HAAT are permitted if power levels are reduced below 1000 watts/MHz ERP.

GPS Compliance

The GPS is in compliance with the essential requirements and other relevant provisions of Directive 1999/5/EC."

The GPS complies with the following EMC Common Regulatory Testing standards:

- EN55022: Radiated and Conducted Emissions
- CISPR 22: Class B
- EN 50081-1: Generic Emissions Class B
- EN 50082-1: Generic Immunity Class B
- EN 61000-4-2: Electrostatic Discharge Immunity
- EN 61000-4-3: Radiated RF EM Field Immunity Test
- EN 61000-4-4: Electrical Fast Transient/Burst Test
- EN 61000-4-6: Conducted Immunity
- EN 61000-4-8: Magnetic Field Immunity



Note: A GPS is required for synchronizing between TDD sectors.



Note: A GPS Lightning/Surge protector is required. (ordered separately)



Maximum Output TX Power

Table 1 - Air4G FCC Maximum Output TX Power

Frequency Band	FCC		Antenna Gain
	TX	EIRP	
700 MHz	41.6 dBm	55.1 dBm	13.5 dBi
800 MHz	pending	pending	pending
1.8 GHz	pending	pending	pending
2.3 GHz	40.26dBm	58.46dBm	18dBi
2.50 GHz	43.22dBm	61.22dBm	18dBi
2.56 GHz	43.15dBm	61.15dBm	18dBi
2.62 GHz	43.42dBm	61.42dBm	18dBi
3.65 GHz	36.88dBm	38.88dBm	2dBi
5.725-5.850 GHz	19.48 dBm	35.98 dBm	16.5 dBi

Table 2 - Air4G ETSI Maximum Output TX Power

Frequency Band	ETSI		Rest of the World		Antenna Gain
	TX	EIRP	TX	EIRP	
698-746 MHz	41.6 dBm	55.1dBm	41dBm	55dBm	13.5dBi
821-869 MHz	pending	pending	pending	pending	pending
1800-1830 MHz	pending	pending	pending	pending	pending
2290-2350 MHz	43dBm	61dBm	43dBm	61dBm	18.0dBi
2340-2400 MHz	43dBm	61dBm	43dBm	61dBm	18.0dBi
2496-2570 MHz	43dBm	61dBm	43dBm	61dBm	18.0dBi
2560-2630 MHz	43dBm	61dBm	43dBm	61dBm	18.0dBi
2620-2690 MHz	43dBm	61dBm	43dBm	61dBm	18.0dBi
3300-3400 MHz	40dBm	58dBm	40dBm	58dBm	18.0dBi
3400-3500 MHz	40dBm	58dBm	40dBm	58dBm	18.0dBi
3500-3600 MHz	40dBm	58dBm	40dBm	58dBm	18.0dBi
3600-3700 MHz	40dBm	58dBm	40dBm	58dBm	18.0dBi
3650-3675 MHz	40dBm	42dBm	40dBm	42dBm	2dBi
3700-3800 MHz	40dBm	58dBm	40dBm	58dBm	18.0dBi
5.47-5.95 GHz	10.5 dBm	27 dBm	28 dBm	44.5 dBm	16.5 dBi



Caution: Do not set maximum output TX power to higher than local regulations.



Power Consumption

Table 3 - Power Consumption

Frequency Range	WiMAX Operation (Nominal)	LTE Operation (Nominal)
5.x	150W	184W
3.x	137W	171W
2.x	200W	236W
1.x	173W	207W
700/800M	129W	163W

Antenna Types

Table 4 - 700 MHz Antenna Types - Technical

Type	Frequency range	Gain	Part number
60° 13.5 dBi Dual X-Polar – mounting kit (50 > 115 mm) included	698 - 806 MHz	13.5 dBi	SEC60Q-700-13.5-1
90° 12.5 dBi Dual X-Polar – mounting kit (50 > 115 mm) included	698 - 806 MHz	12.5 dBi	SEC90Q-700-12.5-1
OMNI Directional	698-746 MHz	6 dBi	MT-221024/NV
OMNI Directional	746-806 MHz	6.5 dBi	MT-221023/NV

Table 5 - 2.x GHz Antenna Types - Technical

Type	Frequency range	Gain	Part number
65° Quad X-Polar – mounting kit (50 > 115 mm) included	2.3-2.7 GHz	18.0 dBi	SEC60Q-2.X-RC-1
90° Quad X-Polar – mounting kit (50 > 115 mm) included	2.3-2.7 GHz	17.0 dBi	SEC90Q-2.X-RC-1
60° Dual Slant X-Polar – mounting kit (50 > 115 mm) included	2.3-2.7 GHz	18.0 dBi	SEC60X-2.X-RC-1
90° Dual Slant X-Polar – mounting kit (50 > 115 mm) included	2.3-2.7 GHz	17.0 dBi	SEC90X-2.X-RC-1
Omni 10dBi Vertical External	2.3-2.49 GHz	10 dBi	ANT2300OV10-360

Table 6 - 3.x GHz Antenna Types - Technical

Type	Frequency range	Gain	Part number
60° Quad X-Polar – mounting kit (50 > 115 mm) included	3.3 - 3.8 GHz	18.0 dBi	SEC60Q-3.5-RC-1
90° Quad X-Pola – mounting kit (50 > 115 mm) included	3.3 - 3.8 GHz	17.0 dBi	SEC90Q-3.5-RC-1
60° Dual Slant X-Polar – mounting kit (50 > 115 mm) included	3.3 - 3.8 GHz	18.0 dBi	SEC60X-3.5-RC-1



Air4G Installation Guide

90° Dual Slant X-Polar – mounting kit (50 > 115 mm) included	3.3-3.8 GHz	17.0 dBi	SEC90X-3.5-RC-1
Omni Reg Compl Vertical Sector	3.3 – 3.5 GHz	10.0 dBi	OMNIV-3.4-RC-2

Table 7 - 5.x GHz Antenna Types - Technical

Type	Frequency range	Gain	Part number
Dual Slant ± 45 degrees 90 Sector	4.9 - 6.1 GHz	16.5dBi	SEC90X-5.X-RC-1

Air4G Antenna Usage

Air4G has four (4) RF ports that can be connected to either:

- A single four-port antenna
- Two dual-port antennas
- Four single-port antennas



Note: Appropriate mounting kit (included) for the dual and quad port antennas are required.

- Quad port cross polarized (X-Pol) antenna with four (4) ports – connected via 4 RF jumper cables to Air4G.
- Dual slant cross polarized (X-Pol) antenna with two (2) ports - connected via 2 RF jumper cables to Air4G.
- Omni antennas – for 360 degree coverage using a single Air4G - requires an Omni antenna for each receiver – 2 or 4 Omni antennas.



Note: The Omni antennas must be separated – with at least one meter separation from each other (in 2.X and in 3.X GHz). Additional separation for 700, 800 MHz and 1.8 GHz.

- Fixed tilt dual/quad port antennas (where the tilt is set by the way the mounting kit is installed).



Note: Required mounting kits for fixed tilt dual/quad port antennas are included.

- Manual Electric Tilt (MET) dual/quad antennas - a variable tilt antenna available for mounting directly on the Air4G with no need for physical tilting of the antenna.

The following table describes different antenna arrays when using either two (2) receivers or four (4) receivers:

Table 8 - Antenna arrays

Frequency Band	# of Receivers	Sector	Antenna Type	# of Antennas
700 MHz	2	60°	698 - 806 MHz 60° 13.5 dBi Dual X-Polar	1
700 MHz	4	60°	698 - 806 MHz 60° 13.5 dBi Dual X-Polar	2
2.3 GHz	2	65°	2.3-2.7 GHz 60° Dual Slant X-Polar	1



Air4G Installation Guide

2.3 GHz	4	65°	2.3-2.7 GHz 60° Quad X-Polar	1
2.5 GHz	2	65°	2.3-2.7 GHz 60° Dual Slant X-Polar Antenna	1
2.5 GHz	4	65°	2.3-2.7 GHz 60° Quad X-Polar	1
3.3-3.8 GHz	2	65°	3.3-3.8 GHz 60° Dual Slant X-Polar	1
3.3-3.8 GHz	4	65°	3.3-3.8 GHz 60° Quad X-Polar	1
700 MHz	2	90°	698 - 806 MHz 90° 12.5 dBi Dual X-Polar	1
700 MHz	4	90°	698 - 806 MHz 90° 12.5 dBi Dual X-Polar	2
2.3 GHz	2	90°	2.3-2.7 GHz 90° Dual Slant X-Polar	1
2.3 GHz	4	90°	2.3-2.7 GHz 90° Quad X-Polar	1
2.5 GHz	2	90°	2.3-2.7 GHz 90° Dual Slant X-Polar	1
2.5 GHz	4	90°	2.3-2.7 GHz 90° Quad X-Polar	1
3.3-3.8 GHz	2	90°	3.3-3.8 GHz 90° Dual Slant X-Polar	1
3.3-3.8 GHz	4	90°	3.3-3.8 GHz 90° Quad X-Polar	1
700 MHz	2	360°	698-746 MHz Omni 5dB/7dBi Vertical External Antenna	2
700 MHz	4	360°	698-746 MHz Omni 5dB/7dBi Vertical External Antenna	4
2.3 GHz	2	360°	2.3-2.49 GHz Omni 10 dBi Vertical External Antenna	2
2.3 GHz	4	360°	2.3-2.49 GHz Omni 10 dBi Vertical External Antenna	4
2.5 GHz	2	360°	Generic Omni	2
2.5 GHz	4	360°	Generic Omni	4
3.3-3.4 GHz	2	360°	3.3-3.5 GHz Omni Reg Compl Vertical Sector	2
3.3-3.4 GHz	4	360°	3.3-3.5 GHz Omni Reg Compl Vertical Sector	4
3.4-3.6 GHz	2	360°	3.4-3.6 GHz Omni Reg Compl Vertical Sector	2
3.4-3.6 GHz	4	360°	3.4-3.6 GHz Omni Reg Compl Vertical Sector	4
3.6-3.8 GHz	2	360°	3.6-3.8 GHz Omni Reg Compl Vertical Sector	2
3.6-3.8 GHz	4	360°	3.6-3.8 GHz Omni Reg Compl Vertical Sector	4
4.9-6.1 GHz	2	90°	Dual Slant ± 45 degrees 90 Sector	1



1 About this Guide

This section discusses the purpose, intended audience, conventions, referenced documentation and organization for this guide.

1.1 Purpose

This guide provides the workflow and step-by-step procedures for Installing the Air4G (formally MacroMAXe). These procedures include:





- Verify Prerequisites
- Install the Air4G
- Connect and Manage Cables
- Set Power System

1.2 Intended Audience

This guide is intended for persons who are responsible for Installing the Air4G. These persons should have a working knowledge of the WiMAX system.

1.3 Conventions

This document uses the following informational conventions.

Icon	Description
	Checkpoint: Marks a point in the workflow where there may be an exit or branch to some other procedure. At each Checkpoint the reason for an exit or branch is given along with specific directions to locate the entry point in the other procedure.
	Reference: Gives a resource in the workflow that may be needed to complete a procedure along with specific directions to use the resource.
	Caution: Describes a possible risk and how to lessen or avoid the risk.
	Advice: Provides a recommendation based on best practice.
	Note: Provides useful information.

1.4 Referenced Documentation

- Air4G Product Specification
- Air4G Overview Guide

1.5 Organization of this Guide

This guide is organized into the following Sections:

- About this Guide
- Introduction
- Get Started
- Verify Prerequisites
- Install the Air4G
- Connect and Manage Cables



Air4G Installation Guide

- Set Power System
- Appendixes [Review Job Sheet, Securing & Connecting the Fiber-Optic cable, Glossary of Terms, Installation Checklist, Contact information and Revision history]



2 Introduction

This section provides a descriptive overview of the Air4G and its place in the product suite.

2.1 Air4G

Air4G is a highly integrated macro-cell base station with all-in-one packaging of RF and baseband components. Air4G includes integrated quad RF transceivers to support four channel diversity and MIMO. It is available as an all outdoor solution for LTE & Mobile WiMAX applications to minimize physical footprint and operator OPEX.

Air4G implements dual 40dBm (10W) transmitters in 2.x GHz, dual 38 dBm (6.3W) in 700 MHz, dual 37dBm (5W) transmitters in 3.x GHz and dual 35dBm (2W) in the 5.x GHz band.

Air4G is an outdoor radio that is mounted outside on a pole or wall. Air4G is available in numerous frequency bands and in numerous channels. For more details please consult the Air4G Product Spec.

Air4G is managed by an SNMP-based network management system (Netspan) using standard and proprietary MIBs. Basic management can be performed using any standard Web browser.



Note: For management refer to Air4G Commissioning documentation.

2.1.1 Deployment Description

A highly flexible and scalable 4G Base Station, the Air4G is capable of supporting either LTE or Mobile WiMAX profiles across multiple frequency bands.



Note: The following is for illustration only; actual layout may differ as infrastructure is installation-specific.



Note: Air4G must be properly grounded according with NEC and other local safety code requirements.



Note: Installation of the GPS Lightning/Surge protector (ordered separately) is necessary to protect the GPS antenna. The Lightning/Surge protector must be properly grounded with NEC and other local safety code requirements.



Note: (U.S.A. – WCS market only) A Cavity filter is required for the 2.3 GHz variant (ordered separately).



Note: An External Duplexer is required for some FDD variants (supplied with Air4G, where required).

Two options for cascading three (3) sectors are illustrated below:

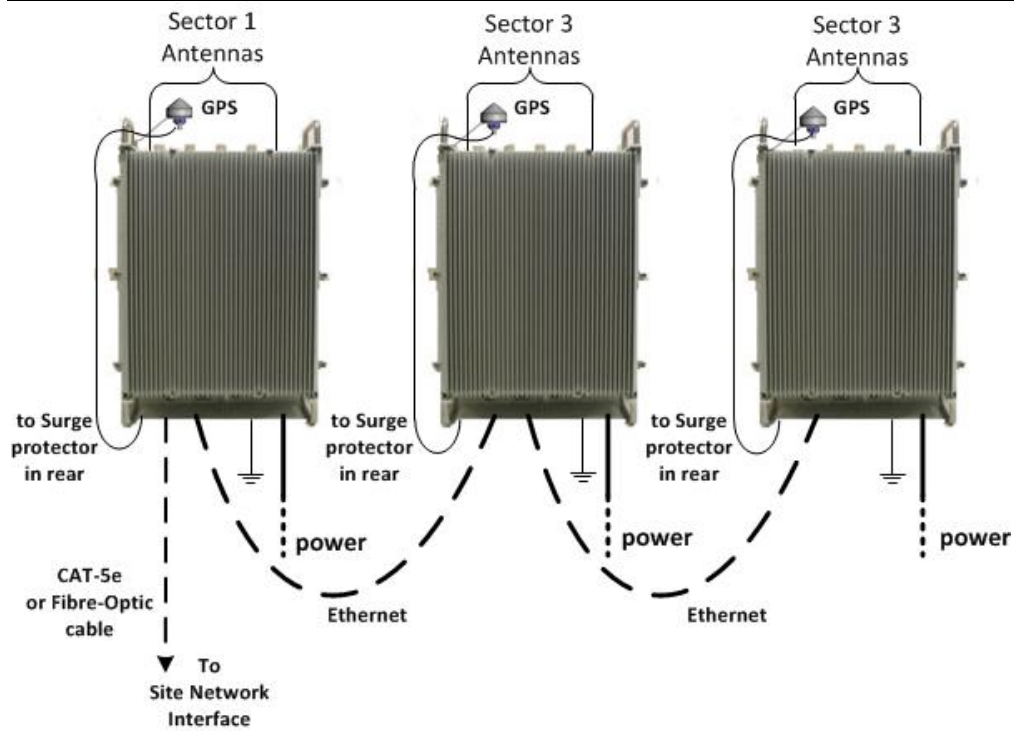

Figure 1 – Air4G – Daisy Chain configuration

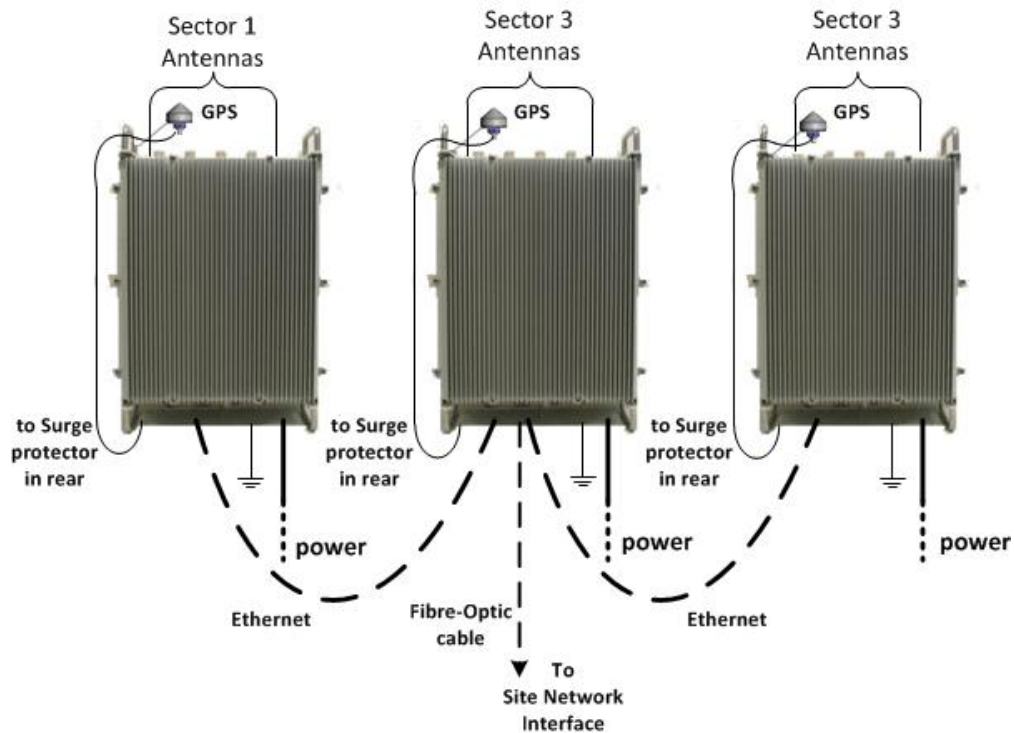

Figure 2 – Air4G – Star configuration

An alternative architecture, where each sector is connected separately to the backhaul/backbone solution, therefore avoiding a single point of failure, as shown below:

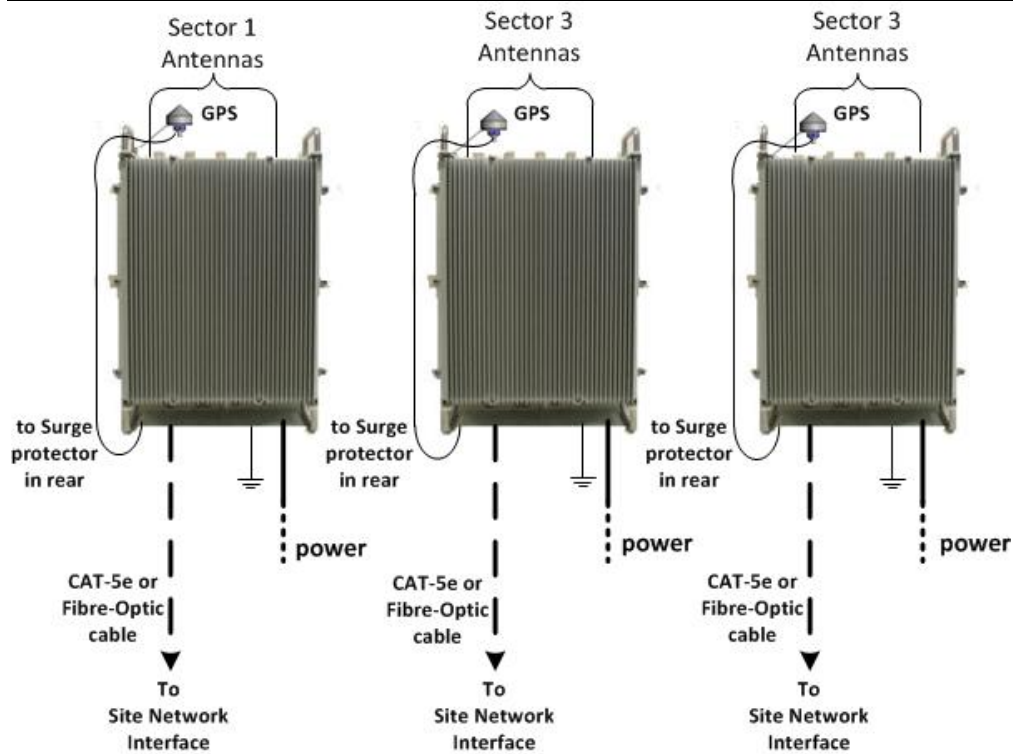

Figure 3 - Air4G – each sector connected separately



Note: Air4G can also be connected via a LAN Switch for greater Failsafe protection.



Note: When the Fiber-Optic cable connection is employed the Ethernet cable connection (Eth 1) is disabled.



Note: Auto-negotiation must always be enabled on the core network side.



Note: The Ethernet connection (Eth 2) can be enabled / disabled via the Air4G WEB interface to prevent unauthorized use. Check to enable, uncheck to disable. See [General Config](#).



Note: Illustrations above display the GPS connected directly to the top of the units, there is also a remote GPS antenna option.

3 Getting Started

3.1 Workflow of Installation

The Workflow to install the Air4G is shown in the following diagram:

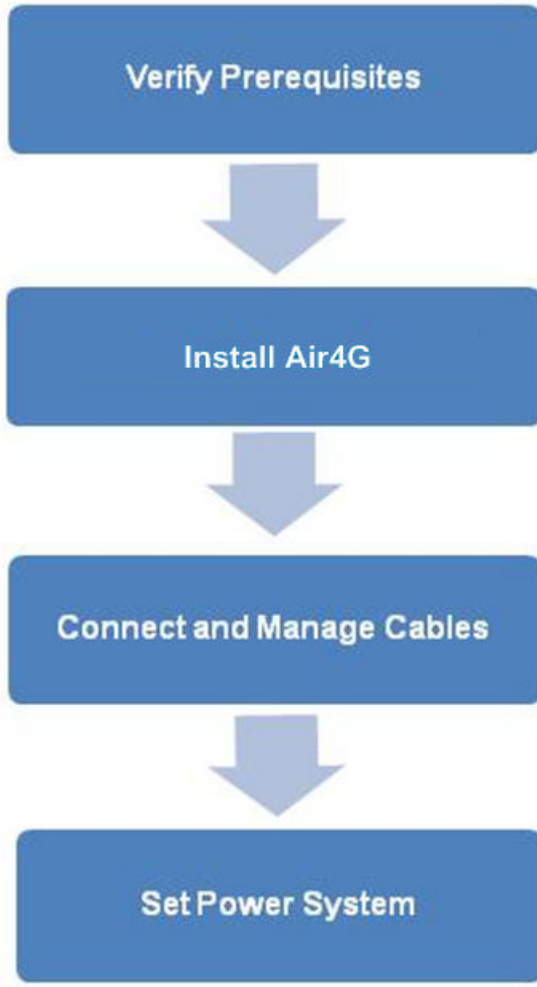

Figure 4 – Workflow of Installation



Caution: Antennas 1 & 2 Tx/Rx must be connected and attached before Air4G is powered on.

3.2 Air4G Installation Checklist

Plan the installation of the Air4G by using the Installation Checklist, which you can find as a removable job aid in [Appendix A](#) for this guide.



4 Verify Prerequisites

Prior to installing the Air4G, verify the required safety, power, tools, parts and components.



Reference: Set up requirements for the installation is detailed in the *Job Sheet*, see [Appendix A](#) for this guide.

4.1 Verify Safety Requirements

Read and follow all warning notices and instructions marked on the product or included in this manual.

When installed in the final configuration, the product must comply with the applicable Safety Standards and regulatory requirements of the country in which it is installed. If necessary, consult with the appropriate regulatory agencies and inspection authorities to ensure compliance.

Ascertain the radiation hazards when working in an environment close to other antennas and Electromagnetic fields, e.g. working on towers with other microwave transmitters etc. and act accordingly.

4.1.1 Warning of Hazardous Voltages

On AC installations, hazardous voltages exist. Use caution when verifying or working with AC power. Remove metal jewelry that could come into contact with AC power.

On DC sections, short circuiting the low voltage, low impedance circuits can cause severe arcing that may result in burns or eye damage. Remove rings, watches etc. to avoid shorting DC circuits.



Note: Airspan products do not contain hazardous substances (as defined in UK Control of Substances Hazardous to Health Regulations 1989 and the Dangerous Substances Regulations 1990). At the end of any Airspan products life cycle, the customer should consult with Airspan to ensure that the product is disposed of in conformance with the relevant regulatory requirements.



Caution: Any modifications to this device not expressly authorized by the manufacturer could void the user's authority to operate this device.

4.2 Verify Installation Requirements

4.2.1 Verify the Tools

Table 9 - Air4G installation tools

Tool
Large Crosshead Screw driver Phillips # 3 or Pozidrive # 3
Small flat blade screwdriver
Medium flat blade screwdriver
13mm or 1/2 inch open ended spanner
10mm or 13/32 inch open ended spanner
Wire strippers
Wire cutters
Ring terminals crimp tool
RJ45 crimp tool



4.2.2 Verify the Parts and Kits

Table 10 - Air4G installation parts and kits

Air4G Base Station parts	Consisting of
1 x Air4G unit	Base station unit
2 x RJ45 Weatherproof Connector Covers	Weatherproof connector covers for use with standard cat 5 RJ45 network connections.  Note: Previous versions had 3 RJ45 connections.
1 x mains cable 14AWG x 2 (ordered separately)	30 meter lead with M17 3 pole plug
When distance from outdoor Power supply to Base Station is over 30 meters additional power cable must be connected via a junction box (ordered separately) for total distance of up to 130 meters.	
	14AWG x 2 (ordered separately) – up to 40 meters
	12AWG x 6 (ordered separately) – up to 100 meters
1 x Ethernet RJ45 environmental shroud	LTW IP68 or Amphenol environmental connector
Sunshield with Antenna Adaptor (optional) (ordered separately)	Air4G-W24-Sunshield – Sunshield kit including quad antenna adaptor brackets (x 2) – including fixing accessories.



Air4G Installation Guide

Air4G Base Station parts	Consisting of
 Note: The Sunshield brackets are only applicable for antennas that utilize Mechanical Electric Tilt (MET). i.e. – Argus-SSPX310F.	
 Warning: A Sunshield is mandatory for temperatures of above 45°.	
1 x Air4G Wall mounting kit	Air4G-W24-WMK-3 – wall mounting kit with accessories included
Pole (& Wall) Mounting Kit for pole with 60-120 mm diameter, No Tilt (ordered separately)	Air4G-W24-PMK-60-120-1 – Pole (with Wall) mounting kit for poles with diameters 60-120 mm – including fixing accessories.
Pole (& Wall) Mounting Kit for pole with 120-230 mm diameter, No Tilt (ordered separately)	Air4G-W24-PMK-120-230-3 - Pole (with Wall) mounting kit for poles with diameters 120-230 mm - including fixing accessories.
1 x earth kit	1 x M5 screws 1 x M5 washers 1 x M5 spring washers Alternative: SEMS screw (includes 2 washers)
AC/DC Power Supply (PS)	Indoor power converter for 5.x GHz, 2.x GHz, 700 MHz
	Indoor or Outdoor power converter for 3.xGHz
Type-IC DC Power Cable	Available either in - 10, 15 or 30 meter lengths. Additional lengths available.
ODC Twin Fiber Cable (Multimode) (optional) (ordered separately)	Available either in - 10, 15, 30, 50, 75 or 100 meter lengths. <hr/>  Note: Maximum up to 500 meters as this is a multimode interface. <hr/>
Multimode fiber pigtail cable (not included) (optional) (ordered separately)	Multimode fiber pigtail cable – ODC - LC connector. Terminates the outdoor fiber cable and provides an indoor LC connector. 2 meter length.
Grounding Cable (required) (not included)	Circular earth braid, 120A current (16 mm ²), jacketed or not with cable size = AWG 4 – 6 with lug (terminal) on enclosure side with hole M6



Air4G Installation Guide





Air4G Base Station parts	Consisting of
Filter (Cavity filter) Kit (for 2.3 GHz variant only) (U.S.A. – WCS market only)	2 x Cavity Filters – 141-00-148 4 x antenna cables – 689-000-47 4 x stainless steel pole bands for pole mounting
External Duplexer Kit (for some FDD variants only) – Supplied with Air4G	1 x External Duplexer (with pre-assembled mounting bracket) 2 x 50-215 mm stainless steel pole bands for pole mounting 4 x RF jumper cables (1.5 m each) for connecting 2 x (Tx + Rx) between the Air4G antenna ports and the Duplexer
RF cable (ordered separately)	2 x antenna cables for connecting the antennas to the Air4G / External Duplexer.

The following table displays the parts contained in the included GPS Kit and when the parts are required per configuration. See [GPS Antenna Assembly](#)

✓ = required when applicable for this configuration



X = not required in this configuration

Table 11 - GPS Kit Contents

Part	Description	Air4G	Air4Gp		Air4Gs	Image
			Ext.	Int.		
GPS Antenna	1 x GPS Antenna. An active GPS antenna which, with the appropriate mounting bracket is used with the BS for network synchronization.	✓	✓	✓	✓	
80cm GPS Cable - RG58 TNC-TNC See Optional Cables	For mounting the GPS directly to the top of the BS. Should be used in conjunction with the BS GPS antenna mounting bracket pre-assembled on the BS. P/N CBL-GPS-TNC-0.8-1	✓	✓	✓	✓	
Remote GPS Antenna Mounting Bracket	Used in conjunction with the long GPS Cable - when mounting GPS remotely. (see optional cables below)	✓	✓	✓	✓	
Lightning/Surge protector	Surge Protector designed to protect from lightning strikes. An additional mounting bracket included in the packaging is not required for use.	✓	✓	✓	✓	
<div style="display: flex; align-items: center; justify-content: center;">  <p>Warning: Surge protection requires proper grounding to provide proper protection against surge damage due to lightning or other surge events.</p> </div>						



Air4G Installation Guide

Part	Description	Air4G	Air4Gp		Air4Gs	Image
			Ext.	Int.		
30cm Surge to BS Cable	For connecting the Surge protector to the Base Station. (RF cable assy TNC to TNC- RA,30cm,RG58)	✓	✓	✓	✓	
Protector mounting bracket	For mounting the Surge protector to the BS.	✓	✓	X	✓	
Protector mounting bracket clamp	For clamping the bracket to the BS. Includes necessary hardware.	✓	X	X	X	

Optional Cables

- 16m GPS Cable - RG58 TNC-TNC - For mounting remotely from the base station unit. Should be used in conjunction with the Remote GPS Antenna Mounting Bracket - P/N CBL-GPS-TNC-16-1
- 40m GPS **Shielded** Cable TNC-TNC for remote GPS mounting option. An optional shielded cable for when excessive interference is detected, such as strong TV transmission interference.– P/N CBL-GPS-TNC-40-1



Note: For additional cable lengths contact your Airspan representative.

The Air4G power supply (PS) can be installed with various cable lengths according to the site requirements. The cable lengths are determined by the length of the run between the PS and the Air4G. Use the following table to determine the required power supply output to ensure proper operation of the Air4G.

Table 12 - Input Power for Air4G

	Air4G 2x10 (2.3-2.7 GHZ) & Air4G 0707 (698-746 MHz)	Air4G 3x05 (3.3-3.38 GHZ)	Air4G 5.x
Input Voltage to Air4G (1)	-36 VDC to -60 VDC	-36 VDC to -60 VDC	-36 VDC to -60 VDC
PS output Voltage – 30 meter cable (2)	-42 VDC min	-41 VDC min	-41 VDC min
PS output Voltage – 75 meter cable (2)	-50 VDC min	-46 VDC min	-45 VDC min
PS output Voltage – 100 meter cable (2)	-53 VDC min	-49 VDC min	-48 VDC min

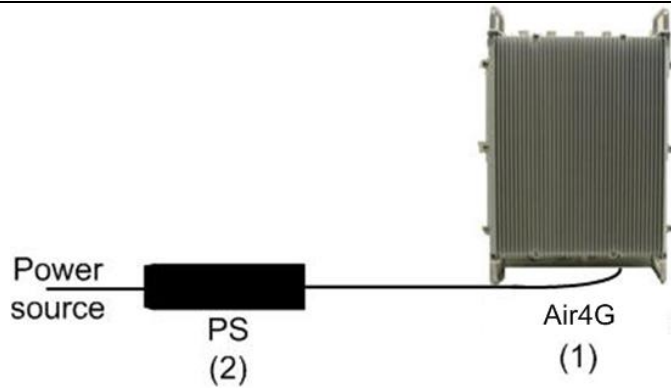

Figure 5 - PS – Air4G



Air4G Installation Guide

Table 13 - Air4G wall mount installation parts





Parts		Images
1	Wall Plate	
2	Top Hanger	
3	Lower Hanger	
4	GPS Antenna mounting bracket w/Handle (pre-assembled)	
5	Handle (pre-assembled)	

Table 14 - Air4G pole mount installation parts

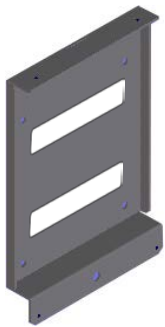

Parts		Images
 Note: in addition to the Wall mounting kit.		
1	Top & Lower Pole Strap (x2) for 120 > 230 MM (short or long straps as appropriate) Top & Lower bracket (x2)	
 Note: in addition to the Wall mounting kit.		
2	Pole bracket for 60 > 120 MM	



Table 15 - Air4G additional parts and kits

Additional Common Accessories (not provided by Airspan)
Spare RJ45 connectors
Cable ties
Ring terminal for earth strap. M5 / M6
Earth strap cable (4-6 mm) (yellow and green cable)
Weatherproof / Outdoor mains cable splice kit or termination box.

Table 16 - Cavity filter (for 2.3 variant only) (U.S.A. – WCS market only)

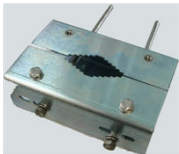
Parts	Images
	<p>Note: the exact filter might appear different than shown.</p>
2 Filter (Cavity filter) (for 2.3 variant only) + antenna cables. (WCS - U.S.A. market only)	
4 4 x pole bands (stainless steel)	

Table 17 - Junction box (optional)

Optional Junction Box	Consisting of
1 x Junction box (ordered separately)	Junction box
1 x PG11 Weatherproof gland (connector), included with junction box	Weatherproof connector 
1 x PG16 Weatherproof gland (connector) , included with junction box	Weatherproof connector 
1 x PG29 Weatherproof gland (connector) , included with junction box	Weatherproof connector 
Additional power cable	14AWG x2 (ordered separately) – up to 40 meters
	12AWG x6 (ordered separately) – up to 100 meters







Optional Junction Box	Consisting of
2 x mounting bracket(s) for pole and wall mounting	Bracket (x2) 
2 x pole bands (stainless steel), as required, supplied.	52 – 76 mm (3") 
2 x pole bands (stainless steel), as required, supplied.	78 – 102 mm (4") 
Mounting screws – for mounting brackets to junction box.	EJOT WN1412 – K50 x 12 – 4 supplied.
Wall mounting fasteners	Hole size = 7 mm
Sufficient cable wires ties, as required	(not supplied - customer responsibility)

Table 18 - External Duplexer (for some FDD variants only)

Parts	Images
 Note: the exact Duplexer might appear different than shown.	
1	External Duplexer (for some FDD variants only) + RF cables. 
1	2 x pole bands (stainless steel) (for 50-215 mm pole) 

4.2.3 Verify Components

Air4G is shown below from the Ethernet termination and RF port end views respectively.

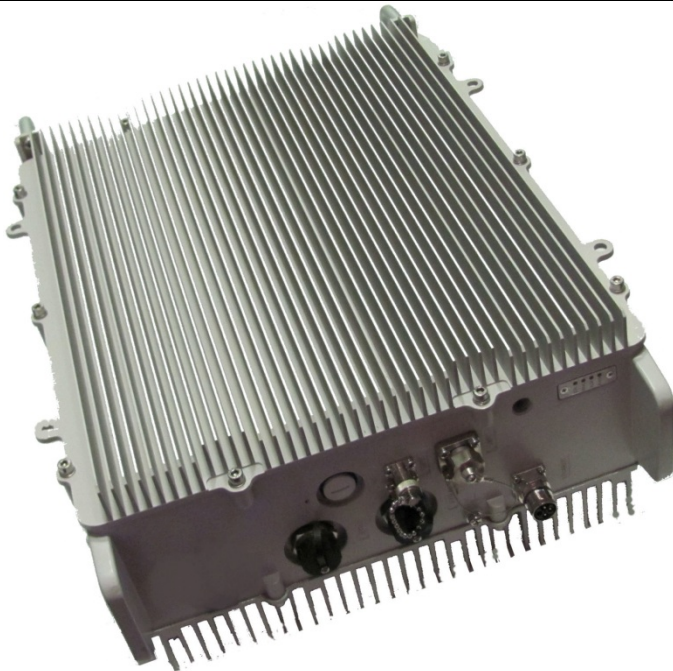

Figure 6 – Air4G Base Station Unit, Ethernet termination



Figure 7 – Air4G Base Station Unit, RF ports

4.2.3.1 Physical Dimensions

Air4G BS is in an all outdoor enclosure.

Table 19 - Air4G 3.x physical dimensions

Parameter	Value	Comment
Height	410 mm (16.14 inches)	The physical dimensions exclude handles and connectors.
Width	350 mm (13.78 inches)	
Depth	155 mm (6.10 inches)	



Air4G Installation Guide

Parameter	Value	Comment
Weight	17 kg (37.47 lbs.)	

Table 20 - Air4G 5.x, 2.x, 1.x, 0808 & 0707 physical dimensions

Parameter	Value	Comment
Height	410 mm (16.14 inches)	The physical dimensions exclude handles and connectors.
Width	350 mm (13.78 inches)	
Depth	170 mm (6.69 inches)	
Weight	17.6 kg (38.80 lbs.)	

RF Ports for antenna connections are N-Type Female connectors located on the top of the Air4G enclosure.

4.2.3.2 Junction Box (Optional)

The Junction box (optional) is an outdoor enclosure that measures 160 mm (6.3 in.), 160 mm (6.3 in.) and 75 mm (2.95 in.). The unit is shown below with the pole mounting bands assembled. The Junction box is required when the distance from the outdoor Power supply to Base Station is **over** 30 meters for total distance of up to 130 meters.



Note: If – 48 volt DC can be verified and guaranteed the Junction box may not be required. Contact customer support to determine.

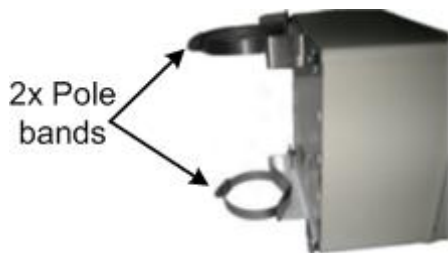

Figure 8 - Junction box with pole assembly

4.2.3.3 External Duplexer (FDD Variant Only)

An External Duplexer is required for some Air4G FDD variants, and is installed adjacent to the Air4G unit. The Duplexer is shown below (in different views) with the pre-assembled brackets. The external Duplexer measures 239 mm (9.41 in.), 232 mm (9.13 in.) and 108 mm (4.25 in.).



Figure 9 - External Duplexer with pre-assembled brackets

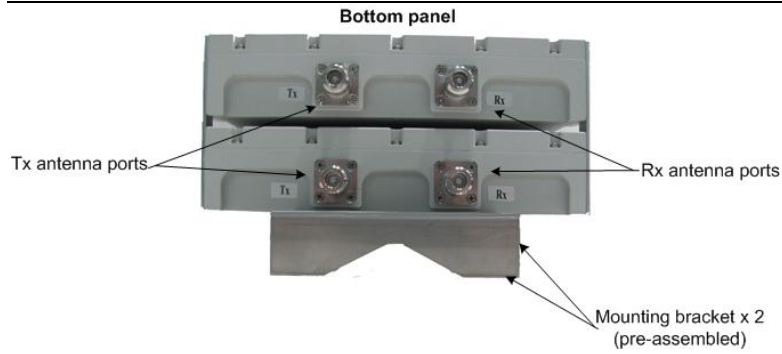

Figure 10 - External Duplexer bottom panel

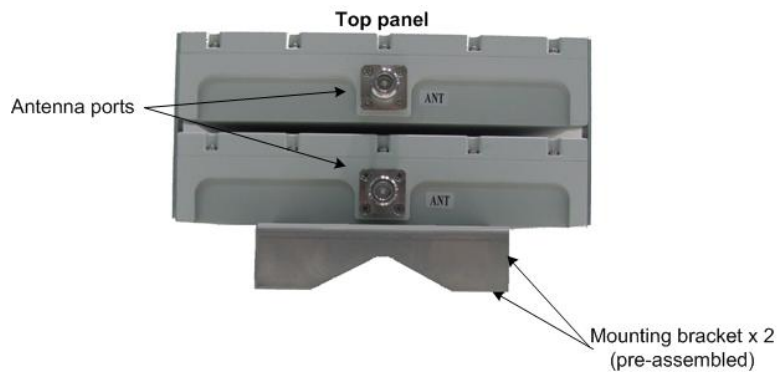

Figure 11 - External Duplexer top panel

Table 21 - External Duplexer variants

Variant	Band	Weight
Air4G-L22-0707LF (700MM2)	12, 17	9.2 Kg (20.28 Lbs.)
Air4G-L22-0806LF (800MM2)	20	7 Kg (15.43 Lbs.)

5 Install Air4G

Install the Air4G base station by pole mount, wall mount, or single point. The Air4G can be connected to various types of antennas via standard RF coaxial cables. Antennas are positioned with up to 10 wavelengths horizontal separation to give optimal Downlink and Uplink MIMO performance.



Caution: Proper local rigging and hoisting practices should be followed when installing the Air4G. The pre-assembled handles are **not** to be used for hanging, attaching or hoisting the unit into place.

5.1 Pole mount configuration

The following image shows the pole mount assembly.

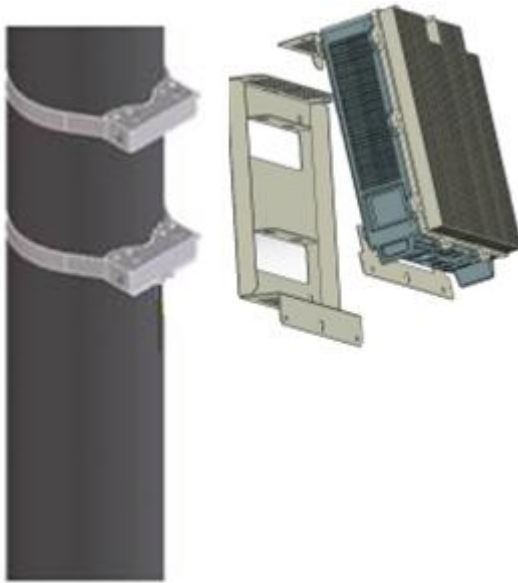

Figure 12 – Pole Mounted Air4G Assembly

To mount the Air4G in the pole mount configuration (for poles 120 > 230 mm), perform the following steps:



Note: Utilize appropriate straps either long (assembled) straps and or short straps (supplied) according to pole diameter.



Figure 13 - pole mounting bracket (2 required)

1. Wrap the band to properly fit on the pole. Set the slot on the hook to insure a tight fit.

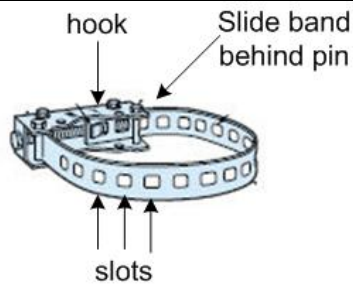

Figure 14 - pole bracket wrap

2. Align and position each of the 2 pole clamp brackets at the heights required to attach the Air4G (with the threaded holes facing up). Adjust the upper bracket and tighten in place. Adjust the lower bracket and hand-tighten.

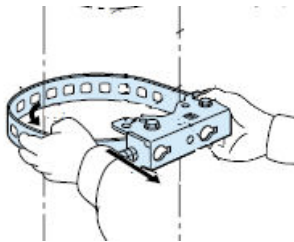

Figure 15 - position brackets on pole



Note: Remove assembled screws (2) and washers (4) for later use.

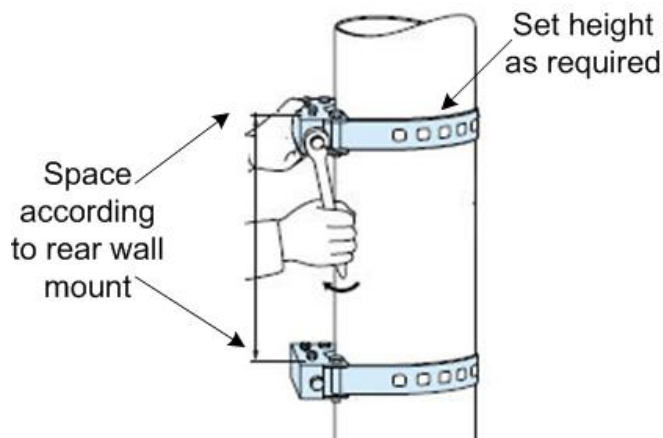

Figure 16 - spacing the brackets

3. Lift the rear wall mount and place the screws through the head clearance holes and position the unit so that the top mounting holes retain the unit.



Caution: These units weigh over 17 kg take care when lifting.

4. Screw the bottom two the M8 screws and washers into the two standoff fittings at the bottom bracket.
5. Check and tighten all fixing screws.



Figure 17 – Pole Mounted Air4G

To mount the Air4G in the pole mount configuration (for poles 60 > 120 mm), perform the following steps:

1. Attach the two (2) pole brackets (as shown in Table 14) to the pole (with the threaded holes facing up) at the heights required to attach the Air4G. This comes as a set of two (2), upper and lower pairs.

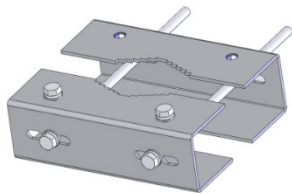

Figure 18 - pole bracket for 60 > 120 mm

2. Tighten upper pole bracket and hand tighten (loosely) the lower pole bracket for later adjustment.



Caution: These units weigh 17 kg – 17.6 kg, take care when lifting.

3. Lift and align the Air4G unit and place the screws through the head clearance holes and position the unit so that the top mounting holes retain the unit and loosely tighten all screws.
4. Tighten all fixing screws.

5.2 Wall mount configuration

The following image shows the wall mount assembly.

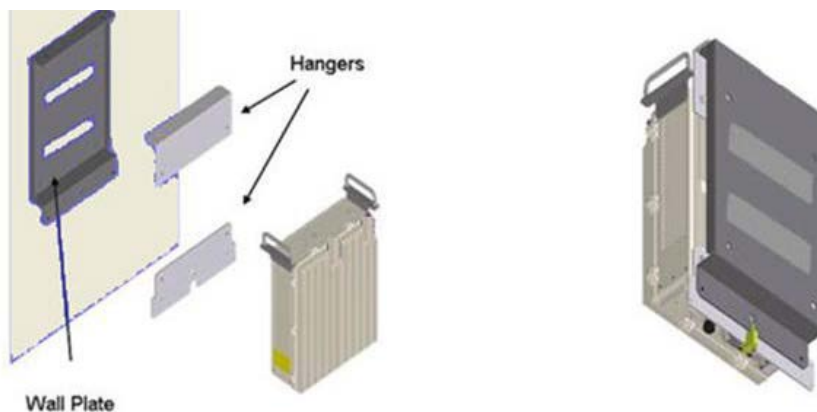

Figure 19 – Wall Mounted Air4G

The following diagram depicts the Wall Plate Details.

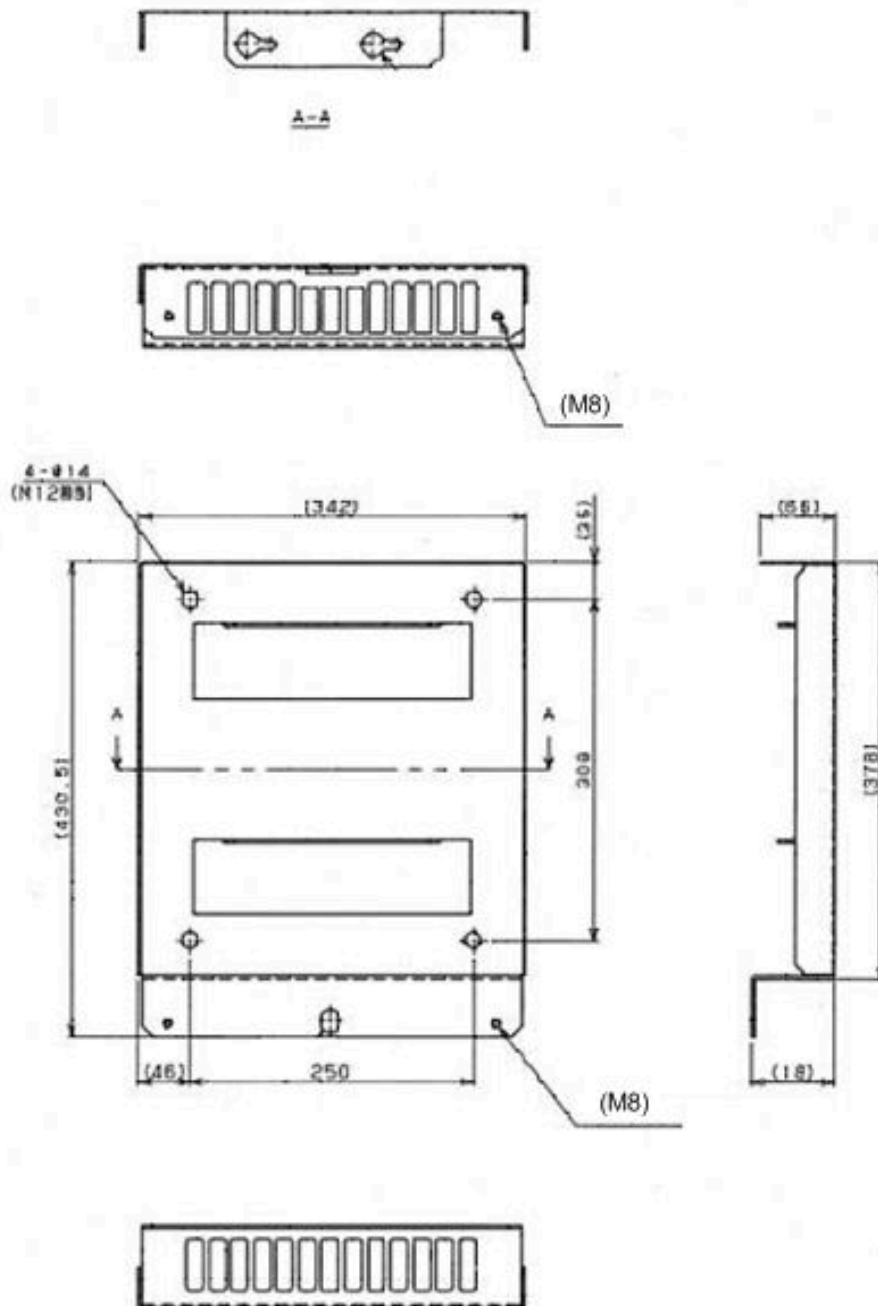

Figure 20 – Wall Mounted Air4G Wall Plate Details

To mount the Air4G in the wall mount configuration, perform the following steps:

1. Attach the Wall Plate to the wall at the height required to attach the Air4G.
2. Fasten the Hangars to the rear side of the Air4G enclosure, position the niched Hangar so it is lower on the wall with the niche facing down.
3. Lift the enclosure and place the screws through the head clearance holes and position the unit so that the top mounting holes retain the unit.



Caution: This unit weighs 17 kg – 17.6 kg, take care when lifting.

4. Screw the bottom two screws and washers into the two standoff fittings at the bottom of the Air4G enclosure.
5. Tighten all fixing screws.

5.2.1 Mounting Examples

The following displays a typical wall mount.

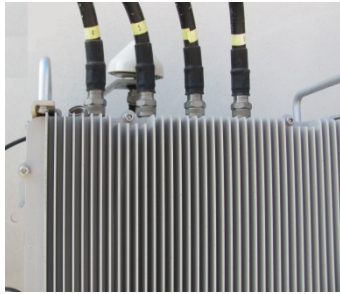

Figure 21 - Wall mount



Note: The GPS bracket (pre-assembled) is on the (back) side closest to the wall so as not to interfere with the sunshield assembly.

The following displays a possible assembly alternative in the event of interference to the GPS by equipment already in place.



Figure 22 - GPS alternative assembly

5.3 Surge Protector Mounting

The Surge protector connects to the base station GPS antenna connector cable on one side and the GPS antenna cable on the other side.



Air4G Installation Guide

A 30cm Surge to BS Cable - RF cable assy TNC to TNC- RA,30cm, RG58, which connects the Surge protector to the Base Station.

A 80cm, cable - RG58 TNC-TNC (P/N CBL-GPS-TNC-0.8-1) for mounting the GPS directly to the top of Air4G. This should be used in conjunction with the BS GPS antenna mounting bracket pre-assembled on the BS.

There is also a 16m GPS cable - RG58 TNC-TNC (P/N CBL-GPS-TNC-16-1), or mounting the GPS remotely from the base station unit. This cable should be used in conjunction with the Remote GPS Antenna Mounting Bracket.

Additionally there is a 40m GPS **Shielded** Cable TNC-TNC (P/N CBL-GPS-TNC-40-1) for remote GPS mounting option. This is an optional shielded cable for when excessive interference is detected, such as strong TV transmission interference. This cable should also be used in conjunction with the Remote GPS Antenna Mounting Bracket.



Note: For additional information about these cables contact your Airspan representative.

The cable assembly for the remote GPS antenna is shown below.



Figure 23 – Air4G Cable for remote assembly of GPS Antenna

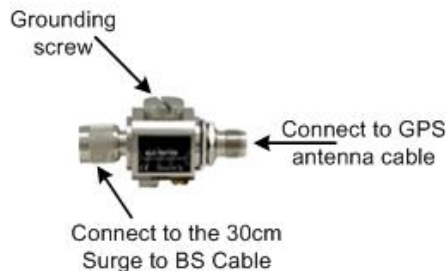

Figure 24 - Lightning/Storm protector (required)

5.3.1 Lightning /Storm Protector Installation







Caution: It is essential for the base station to be installed with protection against surges caused by lightning on the GPS antenna cable. Airspan recommends that a Surge Protector be installed to the base station GPS antenna connector.



Caution: The Surge Protector must be properly grounded according to NEC and other local safety code requirements..

Table 22 - Parts legend

Part #	Description	Image
①	80cm GPS Cable - RG58 TNC-TNC P/N CBL-GPS-TNC-0.8-1	

Part #	Description	Image
②	Lightning/Surge protector	
③	30cm Surge to BS Cable TNC to TNC- RA,30cm,RG58	
④	Protector mounting bracket	
⑤	Protector mounting bracket clamp	

The following is the surge protector installation procedure. Please follow the instructions to ensure proper installation.

1. Attach the Surge Protector mounting bracket clamp ⑤ to the Surge Protector mounting bracket ④ on one (1) of the available slots on the Wall plate. Verify that the 80cm GPS Cable ① (RG58 TNC-TNC) extends from the Surge Protector to the GPS antenna mounted on top of the BS. If the GPS antenna is assembled in an alternate location (not on top of the Air4G), the 80cm cable can be substituted with the 16m or 40m optional cable.
2. Remove the nut from the Surge Protector while leaving the locking washer in place and fasten the Surge Protector to the hole provided on the Surge Protector mounting bracket ④ oriented towards the outer side of the base station (on the same side as the GPS antenna).

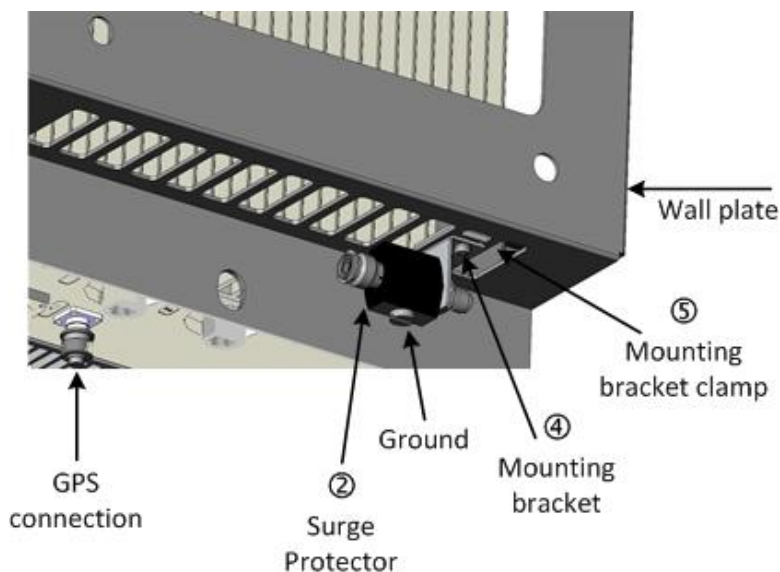

Figure 25 - Surge protector installation

3. Tighten the nut being careful not to over tighten.
4. Feed the 30cm Surge to BS Cable ③ through the closest slot and connect the 90° connector to the GPS connection on the bottom of the BS. Connect the other end to the Surge Protector.
5. Fasten the 80cm GPS Cable ① to the Surge Protector and to the GPS antenna mounted on top of the BS. Tighten but be careful not to over tighten.

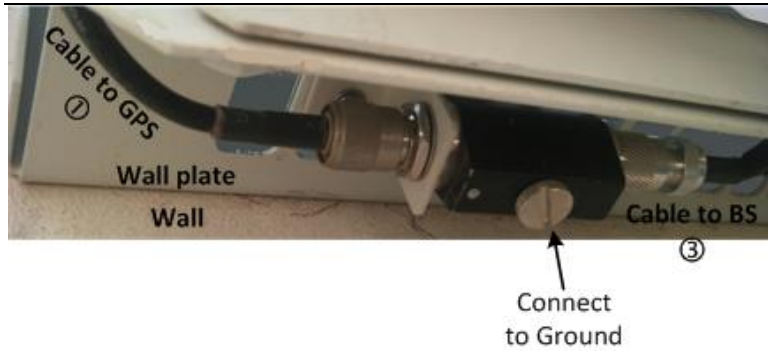

Figure 26 - Surge protector cable connections

6. Connect the Surge Protector to ground it using a AWG#6 cable (green jacket) to tower grounding plate (installed on the tower below the BS). All the base stations and their surge protectors should be grounded in the same way.



Note: The ground plate should be isolated from the tower and connected using AWB#2 wire to the grounding bonding of the tower according to the local code.

5.4 Air4G Connections

The following diagram displays the connections on the bottom side of the Air4G.

The base station requires a secure ground connection. The cable should also be grounded to the tower which is grounded at the tower base. A grounding screw fitted with a flat washer and lock washer is provided on the bottom of the chassis clearly marked with the universal ground symbol as shown below.

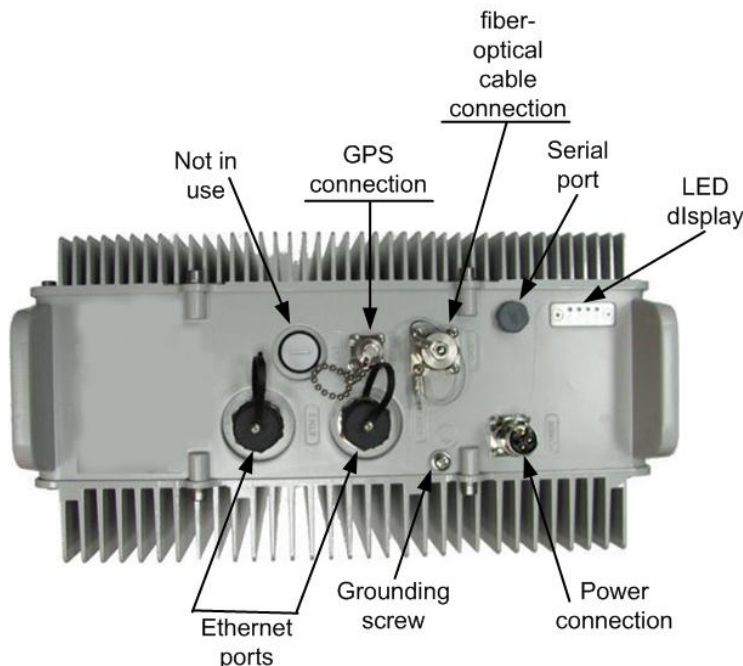

Figure 27 - Air4G connections (bottom)



Note: Previous versions had 3 RJ45 (Ethernet) connections.

5.5 Install Air4G Antennas

Use this procedure to install a linear dual slant antenna for the Air4G in the mast mount configuration.



Figure 28 – Air4G External Antenna Configuration



Note: Separate antenna distance according to RF planning.

5.5.1 Install Dual Slant Antenna



Figure 29 - Air4G Antenna Dual Slant Mast Mount Configuration



Note: Mounting kit (50 > 115 mm) is included.

To mount the dual slant antenna for the Air4G in the mast mount configuration, perform the following steps:



Air4G Installation Guide

1. Attach the Antenna brackets to the top and bottom of the radome.
2. Attach the tilt arm to the top bracket of the radome.
3. Fasten the ends of the adjustable pipe mounts to the top and bottom brackets of the radome.
4. Lift the radome and place the screws through the adjustable pipe mounts and position the radome so that the top mounting holes retain the unit.
5. Screw the bottom two screws and washers into the two standoff fittings at the bottom of the radome assembly.
6. Tighten all fixing screws.
7. Attach, connect and secure antenna RF cable between the antenna and the appropriate Air4G Antenna RF connection on the top of the unit.

5.5.2 Install Quad Slant Antenna



Figure 30 – Air4G Antenna Quad Slant Mast Mount Configuration



Note: Mounting kit (50 > 115 mm) is included.

To mount the Quad slant antenna for the Air4G in the mast mount configuration, perform the following steps:

1. Attach the Antenna brackets to the top and bottom of the radome.
 2. Attach to the top bracket of the radome.
 3. Fasten the ends of the adjustable pipe mounts to the top and bottom brackets of the radome.
 4. Lift the radome and place the screws through the adjustable pipe mounts and position the radome so that the top mounting holes retain the unit.
-

5. Screw the bottom two screws and washers into the two standoff fittings at the bottom of the radome assembly.
6. Tighten all fixing screws.
7. Attach, connect and secure antenna RF cable between the antenna and the appropriate Air4G Antenna RF connection on the top of the unit.

5.5.2.1 Antenna Mounting Clamps for Dual and Quad Slant Antennas

The following are some adjustable antenna mounting clamp options for both Dual and Quad Slant antenna scenarios.

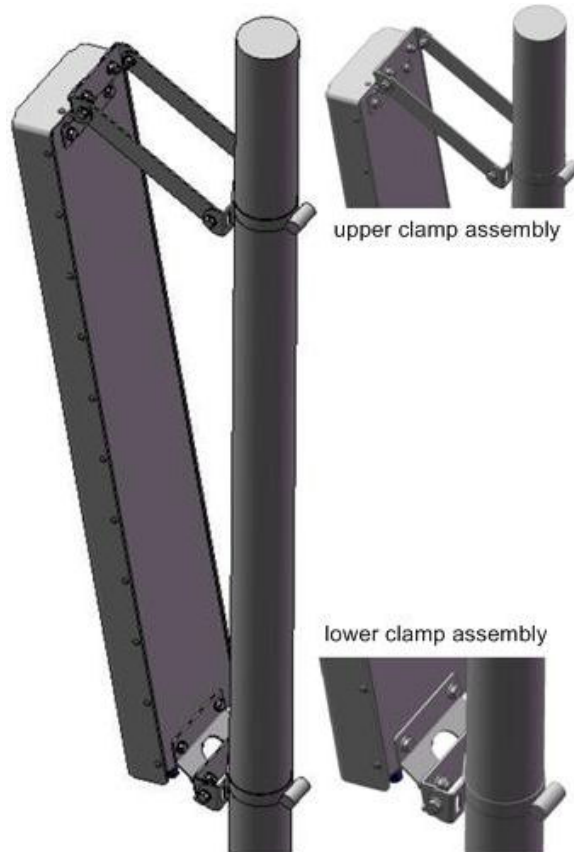

Figure 31 - Adjustable Mounting Kit, with Snaplock Stainless Steel Bands



Figure 32 - Adjustable Mounting Kit, with 'V' Blocks

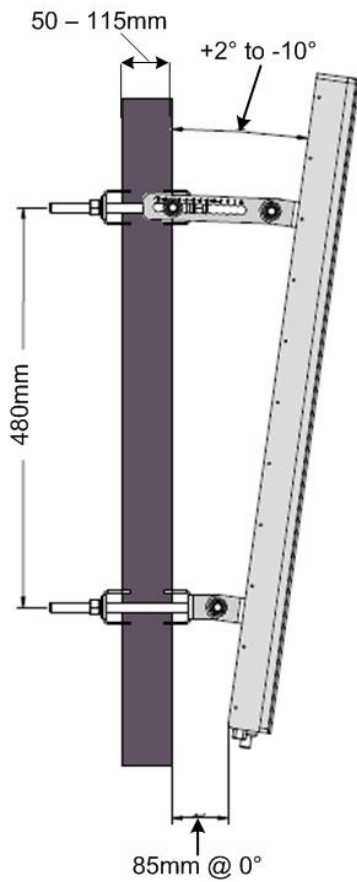

Figure 33 - Adjustable Mounting Kit 2, with 'V' Blocks

5.5.3 Install Omni Antenna

This describes the mounting of the Omni mast mount antenna (ordered separately).



Figure 34 - possible Omni antenna array

To mount the Omni antenna for the Air4G in a mast mount configuration, perform the following steps:

1. Assemble Omni antenna array on the ground at the installation site.
2. Attach the antennas to the mast and connect the cables while on the ground.
3. Use the mounting brackets provided with the antenna(s).
4. Carefully connect the antenna and mast assembly to its mounting bracket and tighten the clamp bolts.



Note: This assembly requires more than one (1) person to assemble in place.

The recommended distance between Omni antennas is determined by the frequency band, as shown in the table below:

Table 23 - recommended distance

Frequency	Distance between antennas
5.x	0.55 meters
3.x	0.85 meters
2.x	1.20 meters
0707	4 meters

5.6 Optional Mounting Antenna on Air4G

Either Antenna shown can be mounted on the Air4G unit or mast mounted.



Note: The sunshield kit is required for this type of assembly. Contact your supplier to order.

5.6.1 Variable Tilt Antenna

There is a Variable Tilt Antenna available for mounting on the Air4G. The antenna may be connected directly to the Air4G with no need for physical tilting of the antenna. The Manual Electric Tilt (MET) antenna has a rotating nut that adjusts a threaded rod which moves in and out while displaying a tilt scale, as shown below.

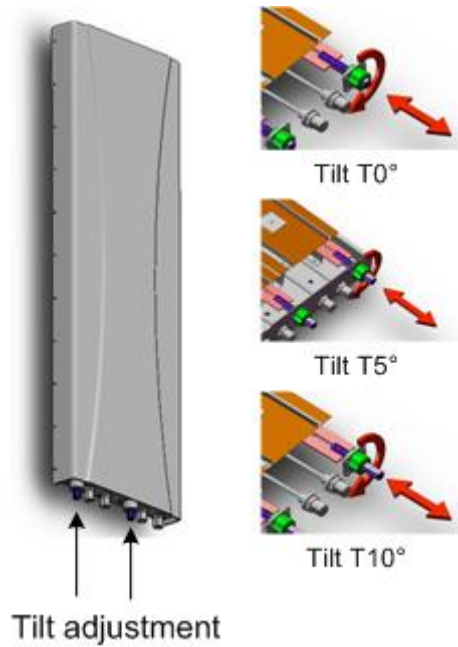

Figure 35 - Variable tilt antenna

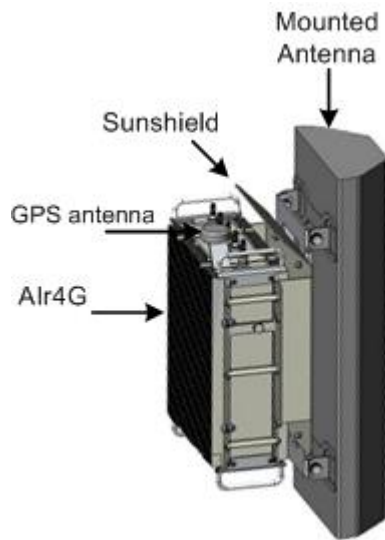

Figure 36 - Antenna mounted on Air4G

5.7 Cavity Filter Installation

The following demonstrates the correct installation of a Cavity filter for the Air4G in either the wall or mast mount configuration.



Note: The Cavity filters are required for the 2.3 GHz variant only.

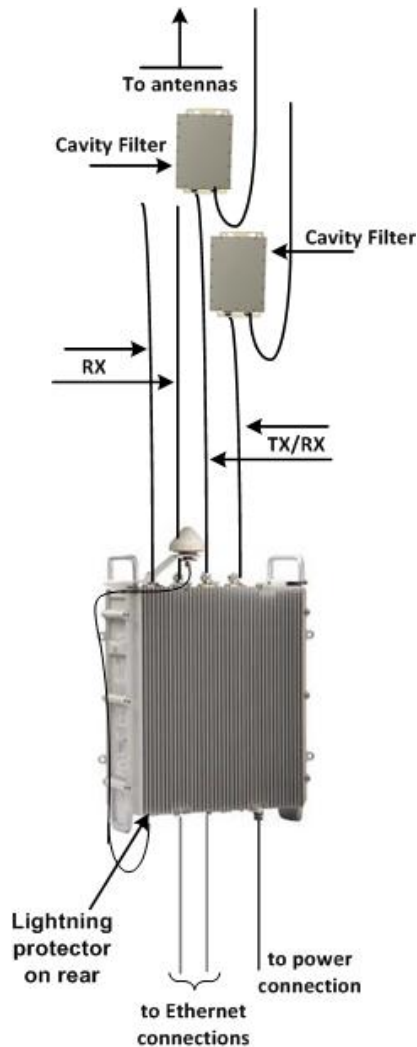

Figure 37 - Cavity filter(s) installation

5.8 External Duplexer Installation

The following demonstrates the installation of the external Duplexer for the Air4G in the pole mount configuration.



Note: The external Duplexer are required for some FDD variant **only**.

To mount the External Duplexer in the pole mount configuration (for poles 50 > 215 mm), perform the following steps:



Note: Utilize the supplied bands according to pole diameter.

1. Position the external Duplexer above the area where the Air4G will be attached. Verify that the distance between the external Duplexer is well within the length of the provided RF jumper cables, i.e. 1.5 meters or less.
2. Feed the band through the provided slits on the pre-assembled brackets of the external Duplexer and wrap the band to fit around the pole.



Figure 38 - pole mounting stainless steel bands (2 required)

3. Feed the end of the first band into the screw housing and start tightening around the pole. Repeat this step with the second band.
4. After tightening the bands, carefully fold the excess band length back over the band's tightening screw to prevent accidental release, as shown below:



Figure 39 - fold back band

The following displays the Air4G and the external Duplexer mounted.



Figure 40 - Pole Mounted external Duplexer.

5.8.1 External Duplexer to Air4G Connection

The following describes the RF connection between the Air4G (FDD variant) and the external Duplexer:



Caution: Attach the appropriate cable to the antenna and hand-tighten. Torque the N-Type connector to 6.2 - 9.7 in-lbs or 0.7 - 1.1 N-m using either a 19mm or 13/16" open end Torque wrench (depending on coupling type).

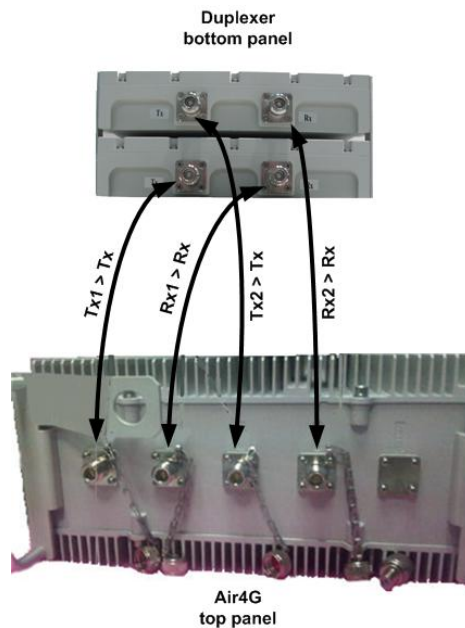

Figure 41 - Duplexer to Air4G connections



Note: The Duplexer antenna ports, on the top panel, are connected to a dual (2) port antenna.

5.9 Antenna Connection



Caution: Tx Antennas must be connected and attached before Air4G is powered on.



Caution: Attach the appropriate cable to the antenna and hand-tighten. Torque the N-Type connector to 6.2 - 9.7 in-lbs or 0.7 - 1.1 N-m using either a 19mm or 13/16" open end Torque wrench (depending on coupling type).



Caution: Power down Air4G prior to disconnecting antenna.

The following describes the antenna connection:



Note: Some antennas are labeled 1, 2, 3, 4 and some are labeled '+', '-', '+', '-'.

The quad port antenna has two dual slant antennas in it (meaning two +/-45 degree antennas) – as such it has two “+45 degree” ports and two “-45 degree” ports.

To provide maximum efficiency one Air4G Tx/Rx port must be connected to a “+45 degree” port in the quad port antenna and another Air4G Tx/Rx port must be connected to a “-45 degree” port in

the quad port antenna. The Air4G Rx ports need to be connected to the remaining connectors on the antenna side. Two (2) examples are displayed below.

Table 24 - Antenna connection

Air4G port	Port Label on Air4G	Port on the quad port antenna
Tx/Rx	ANT 1	+45 degree of "first antenna"
Tx/Rx	ANT 2	-45 degree of "second antenna"
Tx/Rx or Rx only	ANT 3	-45 degree of "first antenna"
Tx/Rx or Rx only	ANT 4	+45 degree of "second antenna"

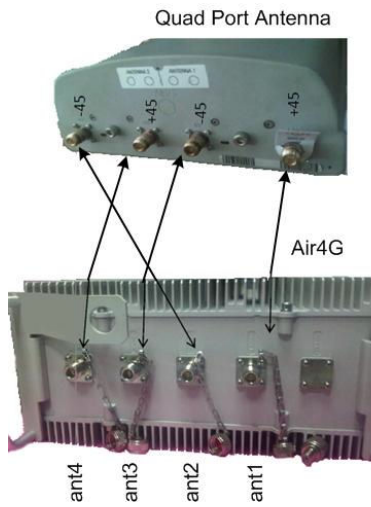

Figure 42 - Quad port antenna connection – 1

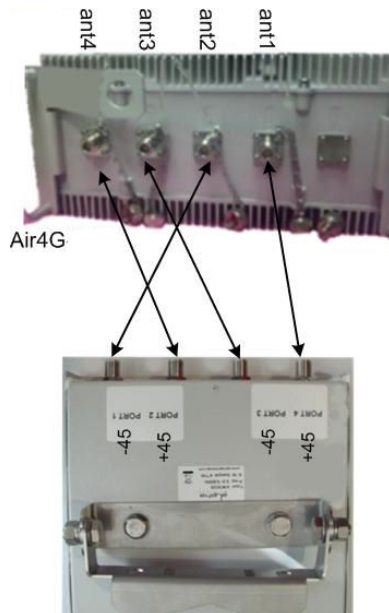

Figure 43 - Quad port antenna connection – 2

5.10 GPS Antenna Assembly

The GPS antenna should be installed far from:

- High-voltage power cables.
- Strong radiation area of any TV transmission stations.

- Radiation area of the main lobe of the RF Antenna.
- Radiation area of the microwave antenna.
- Other areas with inter-frequency interference or strong electromagnetic interference.

Cable Fastening Good Practices:

- No more than 5m between cable fastening spaces.
- No more than 1m between cable termination and first fastener.
- Fastenings should be to a robust construction (i.e. mast pole, BS mount...).
- Fasteners should be weather and UV resistant.
- Cables should have some slack for thermal expansion/contraction between fastenings.

An 80cm, cable connects the GPS directly to the top of Air4G. When mounting the GPS antenna remotely from the base station unit, the GPS antenna should be used in conjunction with the Remote GPS Antenna Mounting Bracket (GPS-MNT-1) and either the 16m (CBL-GPS-TNC-16-1) or the 40m (CBL-GPS-TNC-40-1) GPS Cable RG58 TNC-TNC by way of TNC connectors. The cable assembly for the remote GPS antenna is shown below.

5.10.1 GPS Antenna Mounting

To mount the GPS antenna directly on the Air4G:

5. Route the RG58 cable through the flat washer and the 2 nuts (supplied).
6. Position the RG58 cable below the mounting hole on the GPS antenna mounting bracket, as shown below:

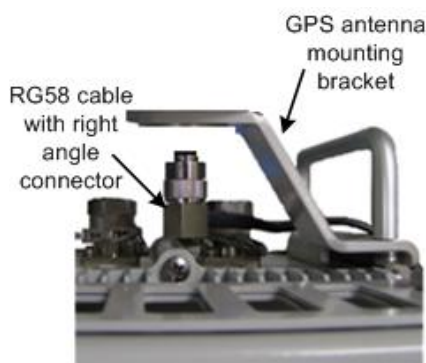

Figure 44 - GPS cable assembly prior to mounting

7. Hand-tighten the RG58 cable TNC (90°) connector to the mating connector on the GPS antenna.

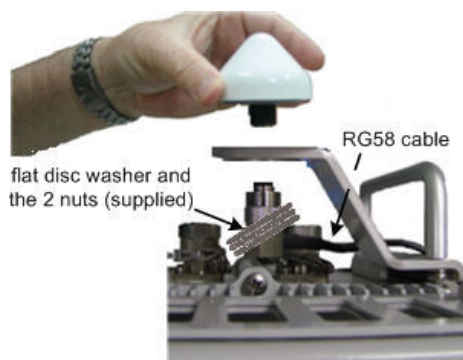

Figure 45 - Attach GPS antenna to RG58 cable

8. Slide the flat washer up to the underside of the mounting bracket, then thread 1 nut onto the GPS antenna threaded base and tightened.

9. The second nut is then secured and tightened against the first nut to create a clamp load against the first nut, as shown below:

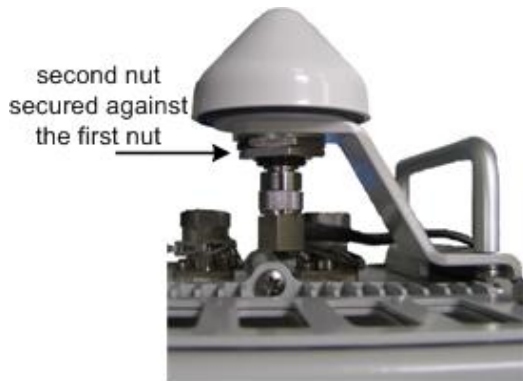

Figure 46 - GPS antenna assembled on bracket

10. Connect the RG58 cable attached to the GPS Lightning/Surge protector (required) to the GPS connection on the bottom Air4G.



Note: Affix the cable to the BS to avoid strain on the connections.

11. Verify that the weatherproof cable is in the proper position and hand tighten the cable (using no tools), to prevent water leakage. Apply self-amalgamating insulating tape on all critical connections.

5.10.2 Remote Mounting of GPS Antenna

When mounting the GPS antenna remotely from the base station unit, the GPS antenna should be used in conjunction with the Remote GPS Antenna Mounting Bracket (GPS-MNT-1) and either the 16m (CBL-GPS-TNC-16-1) or the 40m (CBL-GPS-TNC-40-1) GPS Cable RG58 TNC-TNC.



Note: Care should be taken so that the remote installation of the GPS antenna should be distanced from any obstructions that can interfere with “clear sky” conditions.

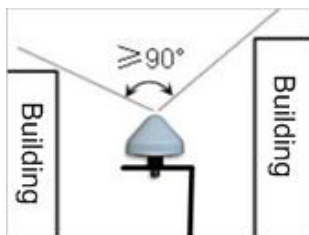

Figure 47 - Clear sky conditions

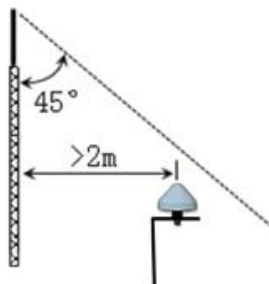

Figure 48 - minimal distance

When interference is present the GPS antenna can be installed in a position lower than the base station using the 40m (CBL-GPS-TNC-40-1) shielded GPS Cable. An example displaying the mounting of the GPS antenna on the tower below the Air4G is displayed below:

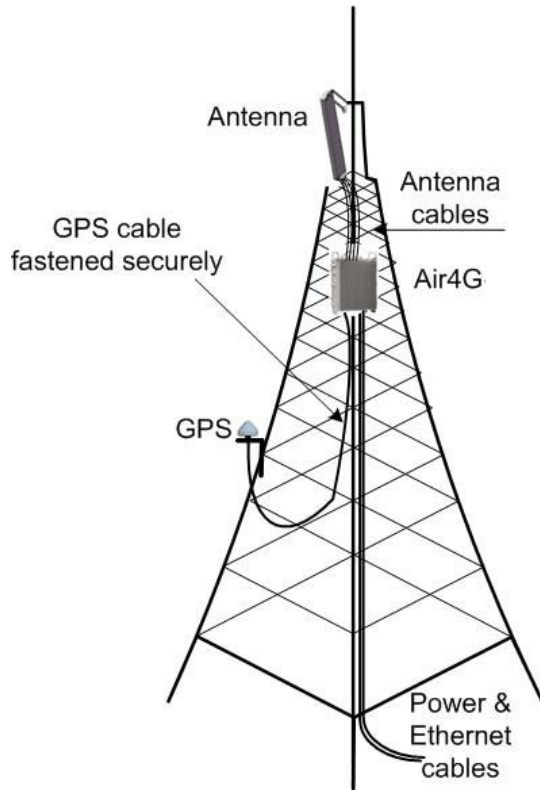

Figure 49 - GPS Remote mounting



Note: All cables should be properly secured to prevent undue strain on any of the cable terminations.

5.11 LED Display

The LED's are a visual display to indicate basic BS status, below is a description of the LED display.

When powering up refer to the following table for indication of BS current status:

Table 25 - LED Display

LED	Name	Color	Status	Description
PWR	Power	Green	On	Power on
			Off	Power off
ALM	Alarm	Red	On	Alarm detected
NML	Network Link	Green	Steady on	Network link detected
			Blinking	Traffic currently flowing
STA	In service	Green	On	Software running

5.12 Install Junction Box (Optional)



Note: Contact Airspan customer-service to determine whether junction box installation is required. Installation may be required, depending on the distance between the external power-supply and the BS, as well as the minimum voltage supplied by the power-supply.

The Junction box (optional) can be pole-mounted or wall-mounted.



Warning: Mount the junction box in an orientation such that the cable ports (located on the bottom) face downwards. This prevents rain water from settling on the ports, thereby, avoiding damage.

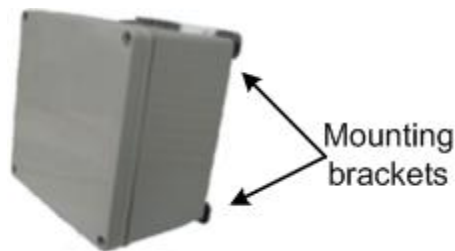

Figure 50 - Junction box with mounting brackets assembled

For either mounting method, the mounting bracket provides mounting holes (displayed below):

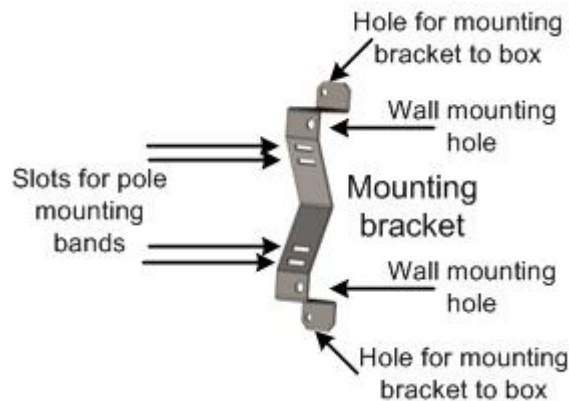

Figure 51 - mounting bracket (2 required)

5.12.1 Junction Box Installation

To install the junction box:

1. Prior to installation connect the 2 mounting brackets to the back of the junction box fastening to the provided holes. The wall mounting hole orientation should be towards the outer edges of the junction box.
2. Remove the junction box's cover, leaving the rubber gasket in place.
3. Prepare the cables for connection by performing the following:
 - a. Strip about 25.4 mm (1 inch) of the outer jacket of the cable to expose the wires.
 - b. Using a wire-stripping tool, expose about 6.3 mm (0.25 inch) of each of the wires by stripping the wires' insulation.
4. Determine which cable entry holes are to be used and remove the appropriate plug.



Air4G Installation Guide

Table 26 - Cable hole sizes

Cable Entry hole determination
Gland hole PG11 (M18) for cable terminating at Air4G
Gland hole PG29 (M36) for cable 12AWG x6
Gland hole PG16 (M22) for cable 14AWG x2



Note: Save the rubber grommets from the plugs to be used on the weatherproof glands (connectors).

5. Remove the nut on the weatherproof connector and slide the rubber grommet onto the threaded shaft.
6. Set the weatherproof connector into the hole and from inside the box, thread the included nut onto the shaft until tight.
7. Insert the exposed wires into the relevant screw-type terminal block (+ to + and – to –) and then secure them in place by tightening the screw of each terminal.
8. Fasten the Junction box onto the pole or wall as required within the required distance of the Air4G enclosure.
9. Perform the same procedure (steps 3-7) with the cable terminating in the in the Air4G enclosure.
10. Open the connector clamp collar and feed about 101.6 mm (4 inches) of cable from the Air4G through it and into the box. Tighten the collar around the cable, forcing the seal to compress around the cable.
11. Replace the cover by using the four (4) screws, ensuring the gasket (for weatherproofing) is firmly in place on the rim of the cover.



Note: It is important to provide strain relief and drip loop for the cables. Create a drip loop and strain relief using cable tie, to tie cable to pole, as displayed in the figure below:

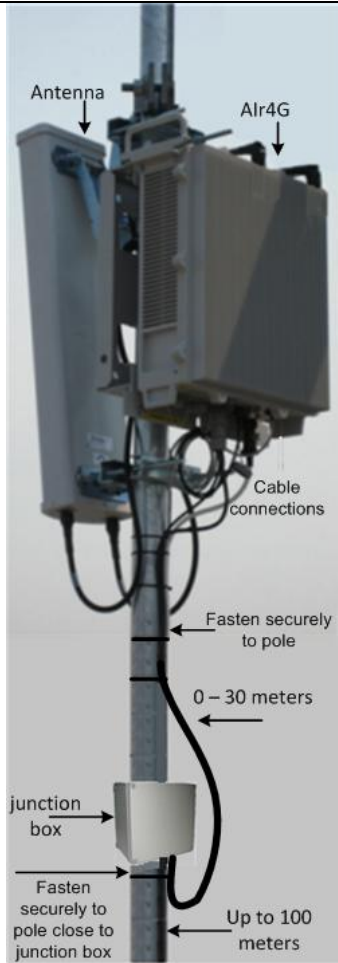

Figure 52 - Air4G assembly with optional junction box

6 Connect and Manage Cables

The Ethernet cable is connected to the Air4G using a standard RJ45 connector protected by a harsh environment protective casing.

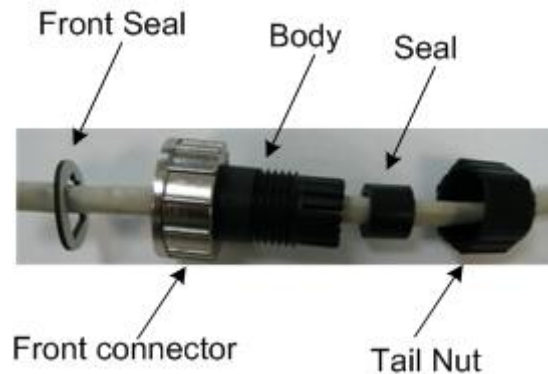

Figure 53 – Ethernet connector cable termination

6.1 Assemble Ethernet Connector

1. Pass the Cat 5 cable through the seal, front connector, body and tail nut of the environmental connector casing as shown above.
2. Paste the front seal on the collar of the connector body.
3. Terminate the Ethernet cable with an RJ45 connector plug.
4. Seat the RJ45 connector plug securely into the body cavity.
5. Tighten the tail nut on to the body forcing the seal to compress around the cable.



Figure 54 – Ethernet environmental connector assembly

7 Set Power System



Hazardous voltage! Before working, ensure that the power is removed from the power connection cables. When the system is powered on, **do not touch the power terminals.**

7.1 Power Input - DC

Each unit is provided with a 3/10/30 meter 48 volt power cable terminated with a female connector at one end to be connected to the Power connector on the bottom panel of the Air4G and bare wires at the other.



Caution: It is important that the power connector is attached at the correct end or damage to the connector/equipment will result.



Note: Check Power Supply for proper polarization.

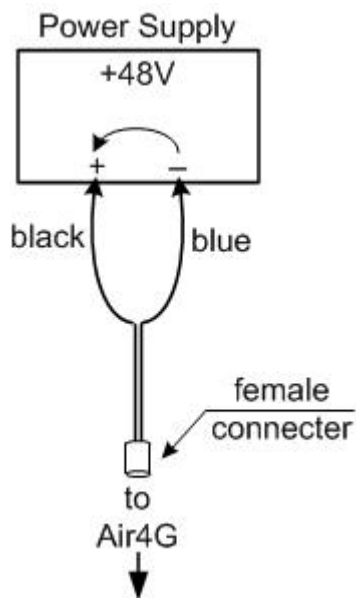

Figure 55 – DC Power connection

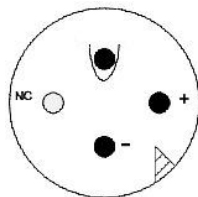

Figure 56 - Power connector – Air4G bottom panel

8 Initial WEB Configuration

Configure an Air4G base station using the built in web based interface. This prepares the equipment for connection to Netspan.

8.1 Initial configuration

To set initial configuration, perform the following:



Caution: The GPS antenna should be installed and attached before Air4G is powered on.



Caution: Wait two minutes before performing other actions.

1. Apply power to the Air4G.
2. With the Air4G powered-up connect the PC to the Ethernet port.
3. Configure the PC with an IP address in the 192.168.0.xxx range (e.g. 192.168.0.xxx subnet 255.255.255.0).
4. In a browser, open web page with address 192.168.0.1 (Air4G default IP address).
5. Enter the default username and password:

Username = air4gweb

Password = thhr49Key

8.1.1 General Config

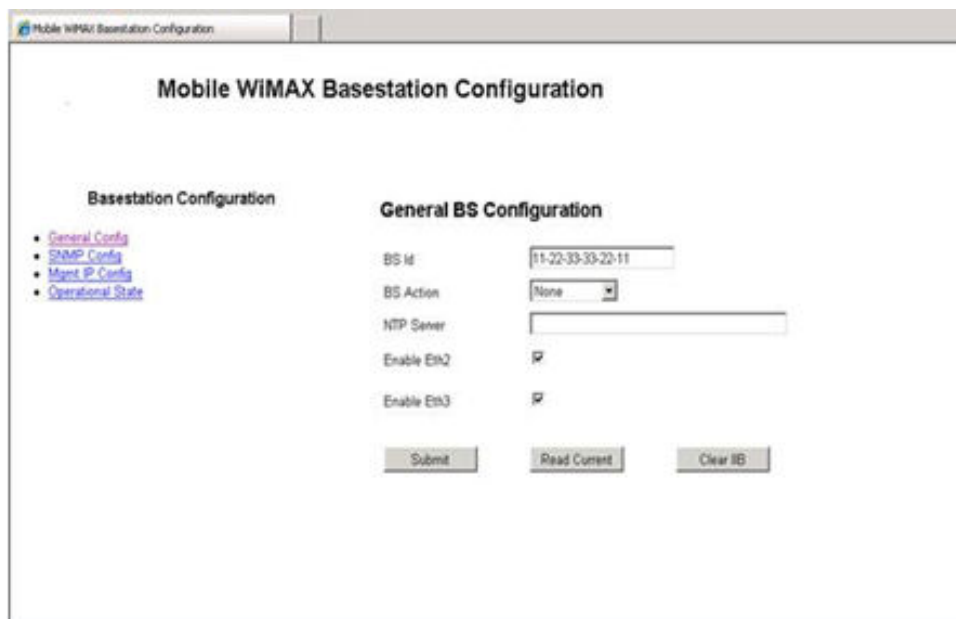

Figure 57 – General BS Configuration Initial



Notes:

- There are 4 connections on the Air4G – optical, Eth1, Eth2 and Eth3.
- The Optical/Eth1 connection is always enabled, and cannot be disabled via the GUI, to prevent comm-loss. When both are connected, the optical takes precedence over the Eth1.

6. Enter the **BS ID**



Note: The format of the BS ID is important: NN-NN-NN-nn-nn-nn (where NN-NN-NN is the Operator ID and nn-nn-nn is a unique address ID).

7. Select the **BS Action** from the available list.
8. Leave **NTP Server** as is (blank).
9. Check **Enable Eth2** – to enable the Eth2 port – disable to prevent unauthorized access to port. Default = enabled
10. Check **Enable Eth3** – to enable the Eth3 port – disable to prevent unauthorized access to port. Default = enabled
11. Click **Submit**. (Read Current = ignore/no action) (Clear IIB = ignore/no action)

8.1.2 SNMP Agent/Trap Configuration

1. Click **SNMP Config**, as displayed below:

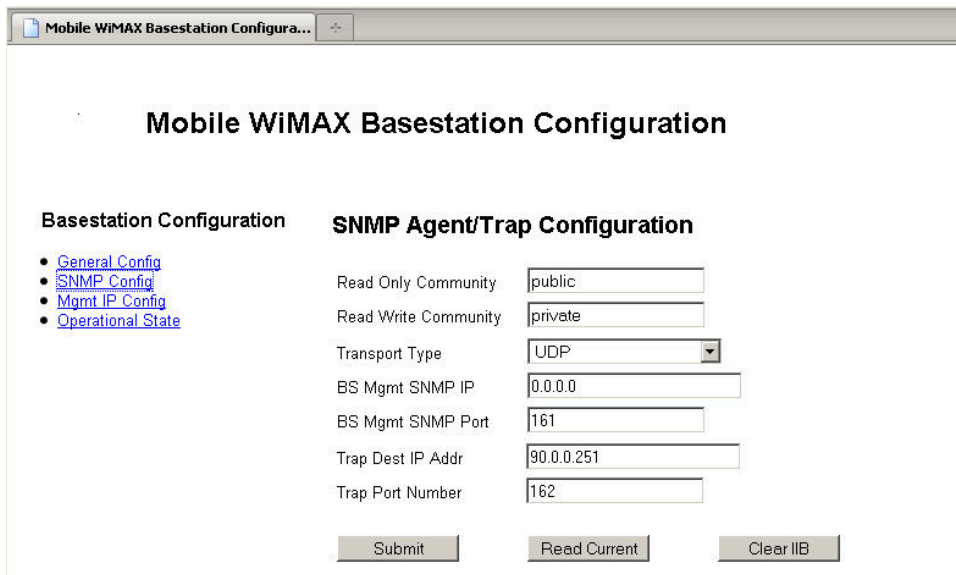

The screenshot shows a web-based configuration interface for a Mobile WiMAX Basestation. The window title is "Mobile WiMAX Basestation Configura...". The main heading is "Mobile WIMAX Basestation Configuration". On the left, there is a navigation menu with links: "General Config", "SNMP Config", "Mgmt IP Config", and "Operational State". The "SNMP Agent/Trap Configuration" section is active and contains the following fields:

- Read Only Community:
- Read Write Community:
- Transport Type: - BS Mgmt SNMP IP:
- BS Mgmt SNMP Port:
- Trap Dest IP Addr:
- Trap Port Number:

At the bottom of the configuration section, there are three buttons: "Submit", "Read Current", and "Clear IIB".

Figure 58 - SNMP Initial Configuration

2. Define **Read Only Community** - SNMP read only community name defined by the BS network provider
3. Define **Read Write Community** - SNMP read/write community name defined by the BS network provider.
4. Leave **Transport Type** as is.
5. Leave **BS Mgmt SNMP IP** as is.
6. Leave the **BS Mgmt SNMP Port** number as is. Default = 161
7. Define the SNMP **Trap Dest IP Addr**. (IP address of Netspan)
8. Set the SNMP **Trap Port Number** (for communications with Netspan) to 162.
9. Click **Submit**. (Read Current = ignore/no action) (Clear IIB = ignore/no action)

8.1.3 Mgmt IP Config

1. Click **Mgmt IP Config**, as displayed below:

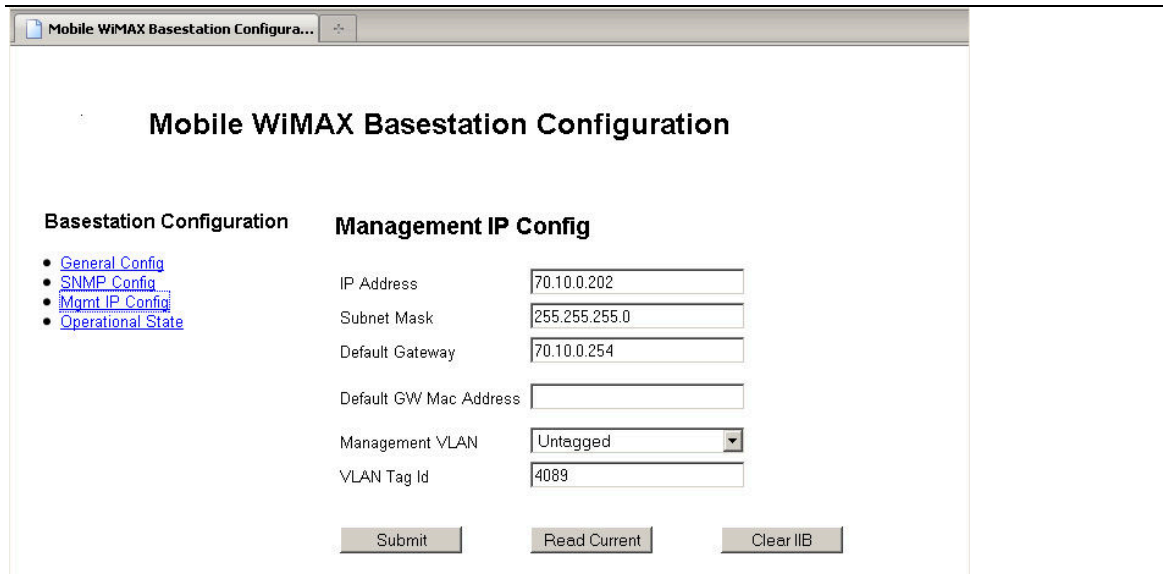

Figure 59 - Management IP Configuration

2. Define the **IP address**.
3. Define the Subnet Mask.
4. Define the Default GW MAC Address.



Caution: Define Default GW only if required for Network Security. Consult with Provider.

1. Set the **Management VLAN** set to Untagged. Set to Tagged when with VLAN Tag ID. Consult with Provider.
2. Define the **VLAN Tag ID** – only when Management VLAN is set to Tagged. Consult with Provider.
3. Click **Submit**. (Read Current = ignore/no action)



Caution: After **Submit** changes are applied immediately to the BS. Therefore the PC must now be re-configured to the new configuration (IP address and Subnet mask) to re-establish communication.

1. Return to [General Config](#) and in the **BS Action**.
2. Select **Reset BS** from the dropdown list.
3. Click **Submit** to perform a reset of the BS.

8.1.4 BS Operational State



Note: Leave settings on BS Operational State as is. No configuration is required.



Air4G Installation Guide

Mobile WiMAX Basestation Configura...

Mobile WiMAX Basestation Configuration

Basestation Configuration

- [General Config](#)
- [SNMP Config](#)
- [Mgmt IP Config](#)
- [Operational State](#)

BS Operational State

Current State:

Requested State:

Figure 60 - Operational State

9 Appendix A

9.1 Review Job Sheet

The *Job Sheet* should include the following information:

- **BS location and identity.**
- Whether the system is required to be locked to a GPS timing reference.
- **A BSID is required for each BS.** This should be in a format xxxxxx:xxxxxx where x is a decimal digit.
- Network configuration information for the BS TRx.
- **Traffic Port:** Not applicable.
- **IP Address:** Should only be set if Management IP Mode is set to Static IP Address. See below for Management IP Mode parameter.
- **Netmask:** Should only be set if Management IP Mode is set to Static IP Address. See below for Management IP Mode parameter.
- **Default Gateway:** Should only be set if Management IP Mode is set to Static IP Address. See below for Management IP Mode parameter.
- **Management VLAN:** Specified as either Untagged or Tagged
- **Management VLAN Tag:** Should only be set if Management VLAN is set to Tagged
- **Management IP Mode:** Specified as Static IP Address or Obtain IP Address via DHCP
- **Ethernet Mode:** Specified as Auto-negotiate or Fixed
- **Ethernet Rate:** Need only be configured if Ethernet Mode is set to Fixed, specified as 10M or 100M.
- **Ethernet Duplex:** Need only be configured if Ethernet Mode is set to Fixed, specified as Full or Half.
 - **SNMP configuration information.** This will allow events from the BS to arrive at the specified Netspan server. This will include the following information:
 - **Read Only Community:** This should be specified to the same value as in Netspan Discovery Parameters (found under Server on Netspan left hand panel).
 - **Read Write Community:** This should be specified to the same value as in Netspan Discovery Parameters (found under "Server" on Netspan left hand panel).
 - **SNMP Port Number:** This should be specified to the same value as in Netspan Discovery Parameters (found under "Server" on Netspan left hand panel).
 - **IP Address:** This specifies Netspan IP address (found under Server Global Configuration, which is under Server on Netspan left hand panel).
 - **Community:** Normally specified to the same value as for Read Only Community.
 - **Port Number:** Normally specified to a value of 9023.
 - **NTP configuration.** This specifies a list of NTP servers.

9.2 Securing Fiber-optic Cable

The Milli-Tie can be used to secure cables in the same manner as normally used for nylon straps. The steps below show the basic use of the product.



Caution: Over-tightening of cable ties may causes damage and degrade system performance.

To secure fiber-optic cables, perform the following steps:

1. Place the Millie-Tie around the target, and thread the tongue through the last large aperture in the rearmost cell.



Figure 61 - Secure fiber-optic cable, place tie

2. Pull or slide the Millie-Tie onto the target. Note that the Millie Tie stretches to cushion the installation.



Figure 62 – Secure fiber-optic cable, pull tie

3. Release the tension when snug, then cut and remove any excess strip. Always cut through the square sections, not the wider cells.



Figure 63 – Secure fiber-optic cable, snug tie



Note: Millie-Tie is efficient, and simply gets a little shorter after each use. The remaining strip can be kept and reused.



Figure 64 – Secure fiber-optic cable, cut excess tie

4. Repeat these steps for each use.



Figure 65 – Secure fiber-optic cable, use excess tie



Figure 66 – Secure fiber-optic cable, re-use excess tie

9.3 Connecting the Fiber-optic Cable

To secure fiber-optic cable to the Air4G, perform the following steps:

1. Remove the dust cover from end of a panel connector:

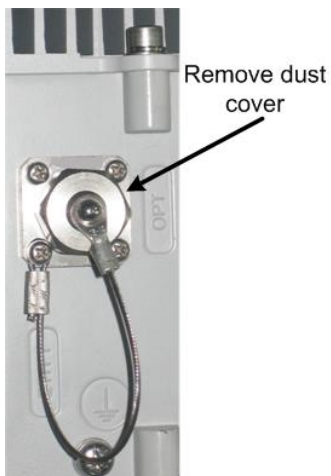

Figure 67 - fiber-optic connector with dust cover



Figure 68 – dust cover removed

2. Remove the protective cover from the fiber-optical cable.
3. Align the fiber-optical cable connector and line up the groove on the cable connector with the pin on the panel connector.
4. Screw the connector cover nut until hand-tight.



Figure 69 - Fiber-Optic Outdoor Connector Plug (multimode)



Figure 70 - screw hand-tight



Figure 71 - Fiber-optic cable connected



10 Appendix C – Glossary of Terms

AAA	Authentication, Authorization and Accounting
AAS	Advanced Antenna System
AF	Application Function
ARQ	Automatic Repeat reQuest
ASN	Access Service Network
ASN GW	ASN Gateway
ATCA	Advanced Telecommunications Computing Architecture
BS	Base Station
BWA	Broadband Wireless Access
CHAP	Challenge Handshake Authentication Protocol
CPE	Customer Premises Equipment
CQI	Channel Quality Indicator
CSN	Connectivity Service Network
DSM	Digital Surface Model
DTM	Digital Terrain Model
EAP	Extensible Authentication Protocol
FA	Foreign Agent
FBSS	Fast Base Station Switching
GUI	Graphical User Interface
HA	Home Agent
H-ARQ	Hybrid Automatic Repeat reQuest
HO	Handover/Handoff
IMS	IP Multimedia Subsystem
IP	Internet Protocol
IPsec	IP security
LR	Location Register
MAC	Media Access Control
MDH	Macro Diversity Handover
MIMO	Multiple Input Multiple Output
MIP	Mobile IP
MRC	Maximal Ratio Combining
MS	Mobile Station
NAP	Network Access Provider
NAS	Network Access Server
NLOS	Non Line of Sight
NSP	Network Service Provider
NWG	Network Working Group



Air4G Installation Guide

OBSAI	Open Base Station Standard Initiative
OFDMA	Orthogonal Frequency Division Multiplexing (Multiple Access)
PA	Paging Agent
PAAA	Proxy AAA
PC	Paging Controller
PF	Policy Function
PHY	PHYSical Layer
PMIP	Proxy MIP
PPP	Point-to-Point Protocol
RADIUS	Remote Authentication Dial In User Service
RRA	Radio Resource Agent
RRC	Radio Resource Controller
RRM	Radio Resource Management
SAS	Smart Antenna System
SDR	Software Defined Radio
SFA	Service Flow Authorization
SFM	Service Flow Management
SIM	Subscriber Identity Module
SIP	Session Initiation Protocol
SOFDMA	Scalable Orthogonal Frequency Division Multiplexing (Multiple Access)
STC	Space Time Coding
TDD	Time Division Duplex
VoIP	Voice over IP
X.509	ITU-T standard for PKI digital certificates



11 Appendix D – Installation Checklist

The Checklist below gives the high-level steps in the Workflow for this procedure. Detach or print this page to use as a job-aid for completing the actions this procedure requires.

Table 27 - Checklist for Procedure

Procedure	Actions	Outcome
1. Verify Prerequisites	Verify safety requirements Verify installation requirements	All requirements are in place for a successful commissioning of Air4G.
2. Install Air4G	Pole mount configuration Wall mount configuration Install Air4G antennas	
3. Connect and manage cables	Assemble Ethernet connector <i>or</i> Disassemble Ethernet connector, <i>then</i> Assemble LTW Ethernet connector	
4. Set power system	Power input Power output	



12 Appendix E

12.1 Revision History

Revision	Originator	Date	Description
Rev A	M. Falik	01-2013	Initial document
Rev B	M. Falik	03-2013	Added Duplexer

12.2 Contact Information

Customer Service Help-Desk for customer service emergency

Airspan Networks have introduced the Airspan Tracker application to enable prompt and efficient Customer Support services.

If you do not have an Airspan Tracker account, please obtain login credentials by filling-in the form in the main page www.airspan.com/Support Register New Account

Worldwide Headquarters:

Airspan Networks Inc.
777, Yamato Road, Suite 310,
Boca Raton, FL 33431, USA
Tel: +1 561 893 8670

www.airspan.com

Feedback:

To provide feedback on this document, please send comments to the following email address: documentfeedback@airspan.com