



UGD-D00068 Rev J

**MicroMAX
Hardware Installation
User Guide**

Software Release 7.7





Acknowledgements

Airspan Networks Inc acknowledges the following trademarks used within this document:

 © Intel Corporation <http://www.intel.com/>

 © SEQUANS COMMUNICATIONS <http://www.sequans.com>

 © Microsoft Corporation <http://www.microsoft.com>

Copyright

© Copyright by **Airspan Networks Inc.**, 2009. All rights reserved worldwide.

The information contained within this document is proprietary and is subject to all relevant copyright, patent and other laws protecting intellectual property, as well as any specific agreements protecting Airspan Networks Inc. rights in the aforesaid information. Neither this document nor the information contained herein may be published, reproduced or disclosed to third parties, in whole or in part, without the express, prior, written permission of Airspan Networks Inc. In addition, any use of this document or the information contained herein for the purposes other than those for which it is disclosed is strictly forbidden.

Airspan Networks Inc. reserves the right, without prior notice or liability, to make changes in equipment design or specifications.

Information supplied by Airspan Networks Inc. is believed to be accurate and reliable. However, no responsibility is assumed by Airspan Networks Inc. for the use thereof nor for the rights of third parties which may be effected in any way by the use of thereof.

Any representation(s) in this document concerning performance of Airspan Networks Inc. product(s) are for informational purposes only and are not warranties of future performance, either expressed or implied. Airspan Networks Inc. standard limited warranty, stated in its sales contract or order confirmation form, is the only warranty offered by Airspan Networks Inc. in relation thereto.

This document may contain flaws, omissions or typesetting errors; no warranty is granted nor liability assumed in relation thereto unless specifically undertaken in Airspan Networks Inc. sales contract or order confirmation. Information contained herein is periodically updated and changes will be incorporated into subsequent editions. If you have encountered an error, please notify Airspan Networks Inc. All specifications are subject to change without prior notice.

Product performance figures quoted within this document are indicative and for information purposes only.



Table of Contents

Acknowledgements	2
Copyright	2
Table of Contents	3
Summary of Figures	7
Summary of Tables	10
Warnings and Cautions	11
Human Exposure to Radio Frequencies.....	11
Radio Interference	11
Avoiding Radio Interference	11
Modifications	11
General	11
DECLARATION OF CONFORMITY	12
FCC Notice	13
Federal Communication Commission Notice	13
GPS Compliance	13
Maximum Output TX Power	14
700MHz Antennas	14
1.4 GHz Antennas	15
2.5 GHz Antennas	15
1 About this Guide.....	16
1.1 Purpose	16
1.2 Intended Audience	16
1.3 Conventions	16
1.4 Referenced Documentation	16
2 System Overview	17
2.1 MicroMAX Frequency Ranges	18
2.2 System Components	19
2.3 Customer Benefits.....	20
2.4 Architecture	20
2.5 Power	21
2.6 Models.....	21
3 Installation Prerequisites	22
3.1 Package Contents	22
3.2 Required Tools.....	23
3.3 Radio Site Planning.....	23
3.3.1 Radio Antenna Alignment	23
4 Physical Description.....	24



4.1 MicroMAX BSR	24
4.1.1 Physical Dimensions	24
4.1.2 Ports	25
4.2 SDA-4S Type II	26
4.2.1 Physical Dimensions	26
4.2.2 Ports	27
4.2.3 LEDs	27
4.3 SDA-4SDC Type II	27
4.3.1 Physical Dimensions	28
4.3.2 Ports	29
4.3.3 LEDs	29
5 BSDU Description	31
5.1 Physical Dimensions	31
5.2 Ports	32
6 GPSD Description	35
6.1 Physical Dimensions	36
6.2 Ports	37
6.3 LEDs	37
6.4 Mounting the GPSD	38
6.5 GPSD Architecture	39
7 GPS Description	41
7.1 Physical Dimensions	41
7.2 Ports	42
7.3 Crimping GPS Cable	42
7.4 Contact Socket Crimping	43
8 AC/DC Power Converter	45
8.1.1 Physical Dimensions	45
8.2 Redundant PS Unit	45
9 Mounting the Base Station Radio (BSR)	46
9.1 Pole-Mounting the BSR	47
9.2 Wall-Mounting the BSR (Optional)	51
9.3 Installing the SDA-4S	54
9.3.1 Wall Mounting	54
10 Mounting the BSDU	56
10.1 Desktop mounting	56
10.2 Rack mounting	56
11 Mounting the GPS	58
12 Mounting the AC/DC Power Converter	59



12.1	Rack Mounting	59
12.2	Connecting Redundant PS Unit	59
13	Cabling the BSR.....	61
13.1	Connecting the BSR to the SDA-4S.....	61
13.2	SDA-4S Type II	62
13.3	Connecting the BSR to BSDU.....	63
13.4	Connecting BSDU to Network.....	65
13.5	Connecting BSDUs	66
13.6	Connecting BSDU for SNMP Management	67
14	Connecting the SDA-4S to the power supply.....	69
14.1	Connecting the SDA-4S Type II	69
14.2	Connecting the SDA-4SDC Type II.....	70
14.3	Connecting SDA-4S to Ethernet Network	71
15	Connecting Power Cable for SDA-4SDC.....	72
15.1	Housing the Connectors.....	72
15.2	Connecting to the SDA-4SDC.....	72
16	Connecting BSDU to AC/DC Power converter	74
16.1	Connections	74
16.2	Power Cable Assembly	75
16.3	Housing the Connectors.....	75
16.4	Cable Connection.....	76
17	Lightning and Surge Protection.....	80
17.1	Lightning Protection	81
17.1.1	Air Terminals	81
17.1.2	Grounding.....	82
17.1.3	Surge Suppression.....	83
17.2	Cable Preparation (for grounding).....	86
17.3	FM Interference & ESD Protection Recommendations.....	87
17.4	Connecting Lightning and Surge Protector	87
17.5	Lightning and Surge Protection Connection Scenarios	90
18	Connecting Third-Party External Antennas.....	93
18.1	Connecting GPS Antenna to BSDU	94
18.1.1	Connecting the GPS	94
18.1.2	GPS Alignment.....	97
19	Appendix	98
19.1	Environmental	98
19.2	Glossary of Terms.....	99
19.3	Revision History	102



19.4	Contact Information.....	102
------	--------------------------	-----



Summary of Figures

Figure 1 - MicroMAX Maximum Output TX Power	14
Figure 2 - Typical Setup	21
Figure 3 - BSR ports.....	24
Figure 4 - SDA-4S Type II	26
Figure 5 - SDA-4SDC Type II	28
Figure 6 - SDA-4S top panel	30
Figure 7 - BSDU front.....	32
Figure 8 - BSDU Front Panel.....	32
Figure 9 - BSDU Rear Panel	34
Figure 10 – GPSD	35
Figure 11 - External antenna (included).....	36
Figure 12 - "Y" cable (4 included).....	36
Figure 13 - GPSD top panel	38
Figure 14 - Wall mount	38
Figure 15 - mounting template.....	39
Figure 16 - GPS antenna.....	41
Figure 17 - GPS dimensions	41
Figure 18 - GPS pinouts	42
Figure 19 - Db-15	42
Figure 20 - Crimping tool (Daniels AFM8).....	43
Figure 21 - Contact crimp tool	44
Figure 22 - Inserting socket into crimper	44
Figure 23 - AC/DC Power Converter.....	45
Figure 24 - RPSU-BSDU-1.....	45
Figure 25 - BSR- rear view	46
Figure 26 - Pole mounting bracket	47
Figure 27 - Mounting bracket attached.....	48
Figure 28 - Pole mount clamping bracket.....	49
Figure 29 - Pole mount U-bolts.....	49
Figure 30 - elevation holes	50
Figure 31 – positioning	50
Figure 32 - strain relief.....	51
Figure 33 - mount separation	51
Figure 34 - mounting template.....	52
Figure 35 - wall-mount bracket.....	53
Figure 36 - attach mounting bracket.....	53
Figure 37 - wall mount.....	54



Figure 38 - SDA-4S mounting template	55
Figure 39 - Rack mounted	56
Figure 40 - GPS pole mounting	58
Figure 41 - PSU front.....	60
Figure 42 - BSR front panel.....	61
Figure 43 - Pinouts	62
Figure 44 - BSR – SDA	63
Figure 45 - BSR-to-BSDU cable connection	65
Figure 46 - BSDU-to-backhaul network.....	66
Figure 47 - Cable connections for BSDU chaining with GPS.....	67
Figure 48 - BSDU-to-PC local network management cabling	68
Figure 49 - Power chord	69
Figure 50 - Connecting to AC power	70
Figure 51 - Connect to Ethernet	71
Figure 52 - Power connectors (Anderson Powerpole)	72
Figure 53 - Contact pin	72
Figure 54 – crimped.....	72
Figure 55 – Insertion.....	72
Figure 56 - Connect to power source	73
Figure 57 - BSDU - AC/DC cable	74
Figure 58 - BSDU to DC cable	75
Figure 59 - Power connectors (Anderson Powerpole)	75
Figure 60 - Contact pin	75
Figure 61 – Crimped.....	75
Figure 62 - Insertion	75
Figure 63 - BSDU to PS MNG port.....	76
Figure 64 - PSU to J1 port.....	76
Figure 65 - Connect to Negative.....	77
Figure 66 - Connect to Positive	77
Figure 67 - Back panels.....	77
Figure 68 - Front power connect	78
Figure 69 - Rear panels.....	78
Figure 70 - Front LEDs	79
Figure 71 - Air Terminal.....	82
Figure 72 - Termination and Tower	82
Figure 73 - Level 1.....	84
Figure 74 - Level 2.....	84
Figure 75 - Level 3.....	85



Figure 76 - Ring terminal	87
Figure 77 – CAT-5e SFTP cable with ring terminal.....	87
Figure 78 - Complete assembly with Ferrite (optional).....	87
Figure 79 - Working with SDA (W/O GPS Sync).....	89
Figure 80 - RJ45 working with SDA.....	89
Figure 81 - Working with BSDU (GPS Sync)	89
Figure 82 - RJ45 working with BSDU.....	89
Figure 83 - Mounting template.....	90
Figure 84 - SDA-4S + Polyphaser + BSR	90
Figure 85 - SDA-4SDC + Polyphaser + BSR	91
Figure 86 - BSDU + Polyphaser + BSR	92
Figure 87 - Antenna connection	94
Figure 88 - BSDU rear panel GPS port.....	95
Figure 89 - GPS connector pinouts	95
Figure 90 - GPS-to-BSDU cable connection	97



Summary of Tables

Table 1 - 700MHz Antenna Types.....	14
Table 2 - 1.4GHz Antenna Types.....	15
Table 3 - 2.5GHz Antenna Types.....	15
Table 4 - MicroMAX Frequency Ranges.....	18
Table 5 - BSR Dimensions.....	24
Table 6 - BSR ports.....	25
Table 7 - SDA-4S dimensions.....	26
Table 8 - SDA-4S ports.....	27
Table 9 - SDA-4SDC dimensions.....	28
Table 10 - SDA-4SDC ports.....	29
Table 11 - SDA-4S LEDs.....	29
Table 12 - BSDU dimensions.....	31
Table 13 - Front Panel Interfaces.....	32
Table 14 - BSDU LEDS description.....	33
Table 15 - Rear panel Interfaces.....	34
Table 16 - GPSD Voltage & Currency Ratings.....	35
Table 17 - GPSD dimensions.....	36
Table 18 - GPSD ports.....	37
Table 19 - GPSD LED description.....	37
Table 20 - GPS dimensions.....	41
Table 21 - GPS Pinouts.....	42
Table 22 - Contact socket crimping.....	43
Table 23 - AC/DC power converter dimensions.....	45
Table 24 - BSR- BSDU connections.....	64
Table 25 - BSDU-to-WAN cable connector pinouts.....	65
Table 26 - BSDU connecting cable connector pinouts.....	66
Table 27 - BSDU to PC for IP network management.....	67
Table 28 - Required Equipment.....	74
Table 29 - Level of Lightning Protection.....	80
Table 30 - Application matrix.....	81
Table 31 – Accessories.....	86
Table 32 - Description.....	92
Table 33 - Connector pinouts for BSDU-to-GPS cabling.....	96
Table 34 - BSR & SDA.....	98
Table 35 – BSDU.....	98
Table 36 - GPSD.....	98



Warnings and Cautions

Human Exposure to Radio Frequencies

The MicroMAX should be installed and operated from a minimum distance of 2 meters to your body.

Radio Interference

This equipment generates, uses, and can radiate radio frequency energy and, if not installed and used in accordance with the instructions, may cause harmful interference to radio communications. However, there is no guarantee that interference will not occur in a particular installation. If this equipment does cause harmful interference to radio or television reception, which can be determined by turning the equipment on and off, the technician is encouraged to try to correct the interference by performing one or more of the following measures:

- Re-orientate or relocate the receiving antenna
- Increase separation between the equipment and receiver
- Connect the equipment to an outlet on a circuit different from that to which the receiver is connected

Avoiding Radio Interference

- This transmitter must not be co-located or operating in conjunction with any antenna or transmitter.
- Ensure a minimum of 1-meter separation between co-located BSRs.

Modifications

Any changes and modifications to this device that are not expressly approved by Airspan Networks may void the user's authority to operate the equipment.

General

- Only qualified personnel should be allowed to install, replace, and service the equipment.
- The device cannot be sold retail, to the general public or by mail order. It must be sold to dealers.
- Installation must be controlled.
- Installation must be performed by licensed professionals.
- Installation requires special training.
- The MicroMAX radio and antenna should be installed ONLY by experienced installation professionals who are familiar with local building and safety codes and, wherever applicable, are licensed by the appropriate government regulatory authorities. Failure to do so may void Airspan's WiMAX product warranty and may expose the end user or the service provider to legal and financial liabilities. Airspan and its resellers or distributors are not liable for injury, damage or violation of regulations associated with the installation of outdoor units or antennas.

DECLARATION OF CONFORMITY

European Community, Switzerland, Norway, Iceland, and Liechtenstein Declaration of Conformity with Regard to the R&TTE Directive 1999/5/EC

English:

This equipment is in compliance with the essential requirements and other relevant provisions of Directive 1999/5/EC.

Deutsch:

Dieses Gerät entspricht den grundlegenden Anforderungen und den weiteren entsprechenden Vorgaben der Richtlinie 1999/5/EU.

Dansk:

Dette udstyr er i overensstemmelse med de væsentlige krav og andre relevante bestemmelser i Direktiv 1999/5/EF.

Español:

Este equipo cumple con los requisitos esenciales así como con otras disposiciones de la Directiva 1999/5/EC.

Greek:

ΜΕ ΤΗΝ ΠΑΡΟΥΣΑ Airspan ΔΗΛΩΝΕΙ ΟΤΙ Ο ΕΞΟΠΛΙΣΜΟΣ ΣΥΜΜΟΡΦΩΝΕΤΑΙ ΠΡΟΣ ΤΙΣ ΟΥΣΙΩΔΕΙΣ ΑΠΑΙΤΗΣΕΙΣ ΚΑΙ ΤΙΣ ΛΟΙΠΕΣ ΣΧΕΤΙΚΕΣ ΔΙΑΤΑΞΕΙΣ ΤΗΣ ΟΔΗΓΙΑΣ 1999/5/ΕΚ.

Français:

Cet appareil est conforme aux exigences essentielles et aux autres dispositions pertinentes de la Directive 1999/5/EC.

Íslenska:

Þessi búnaður samrýmist lögboðnum kröfum og öðrum ákvæðum tilskipunar 1999/5/ESB.

Italiano:

Questo apparato é conforme ai requisiti essenziali ed agli altri principi sanciti dalla Direttiva 1999/5/EC.

Nederlands:

Deze apparatuur voldoet aan de belangrijkste eisen en andere voorzieningen van richtlijn 1999/5/EC.

Norsk:

Dette utstyret er i samsvar med de grunnleggende krav og andre relevante bestemmelser i EU-direktiv 1999/5/EC.

Português:

Este equipamento satisfaz os requisitos essenciais e outras provisões da Directiva 1999/5/EC.

Suomalainen:

Tämä laite täyttää direktiivin 1999/5/EY oleelliset vaatimukset ja on siinä asetettujen muidenkin ehtojen mukainen.

Svenska:

Denna utrustning är i överensstämmelse med de väsentliga kraven och andra relevanta bestämmelser i Direktiv 1999/5/EC.

The Declaration of Conformity related to this product can be obtained from product_management@Airspan.com

FCC Notice

Federal Communication Commission Notice

This equipment has been tested and found to comply with the limits for a Class A digital device, pursuant to part 15 of the FCC Rules. These limits are designed to provide reasonable protection against harmful interference when the equipment is operated in a commercial environment. This equipment generates, uses, and can radiate radio frequency energy and, if not installed and used in accordance with the instruction manual, may cause harmful interference to radio communications. Operation of this equipment in a residential area is likely to cause harmful interference in which case the user will be required to correct the interference at his/her own expense.

Fixed and base stations transmitting a signal with an emission bandwidth greater than 1 MHz must not exceed an ERP of 1000 watts/MHz and an antenna height of 305 m HAAT, except that antenna heights greater than 305 m HAAT are permitted if power levels are reduced below 1000 watts/MHz ERP.

GPS Compliance

The GPS is in compliance with the essential requirements and other relevant provisions of Directive 1999/5/EC."

The GPS complies with the following EMC Common Regulatory Testing standards:

- EN55022: Radiated and Conducted Emissions
- CISPR 22: Class B
- EN 50081-1: Generic Emissions Class B
- EN 50082-1: Generic Immunity Class B
- EN 61000-4-2: Electrostatic Discharge Immunity
- EN 61000-4-3: Radiated RF EM Field Immunity Test
- EN 61000-4-4: Electrical Fast Transient/Burst Test
- EN 61000-4-6: Conducted Immunity
- EN 61000-4-8: Magnetic Field Immunity



Note: A GPS is required for synchronizing between TDD/FDD sectors.

Maximum Output TX Power

Frequency Band	ETSI		FCC		Rest of the World		Antenna Gain
	TX	EIRP	TX	EIRP	TX	EIRP	
698-746 MHz TDD			28.6dBm	43.9dBm	28.6dBm	43.9dBm	15.3 dBi
1.4GHz TDD			27.28dBm	45.28dBm	27.28dBm	45.28dBm	18 dBi
2.4975-2.6885 GHz TDD			28.46dBm	45.46dBm	28.46dBm	45.46dBm	17 dBi
2.7-2.9 GHz TDD (NPI)					27dBm	41dBm	14 dBi
3.3-3.5 GHz TDD	27dBm	41dBm	N/A	N/A	27dBm	41dBm	14 dBi
3.4-3.6 GHz FDD	28dBm	42dBm	N/A	N/A	28dBm	42dBm	14 dBi
3.6-3.8 GHz FDD	28dBm	42dBm	N/A	N/A	28dBm	42dBm	14 dBi
3.7GHz TDD	28dBm	42dBm	23.8	37.8	28dBm	42dBm	14 dBi
4.94-4.99 GHz TDD			26.4	40.9	22dBm	36.5dBm	14.5 dBi
5.15-5.35 GHz TDD	9dBm	23.5dBm			22dBm	36.5dBm	14.5 dBi
5.15-5.25 GHz TDD			2.5dBm	17dBm	22dBm	36dBm	14.5 dBi
5.25-5.35 GHz TDD			12.5dBm	27dBm	22dBm	36dBm	14.5 dBi
5.47-5.725 GHz TDD	16dBm	30dBm	12.3dBm	26.8dBm	22dBm	36dBm	14.5 dBi
5.725-5.850 GHz TDD	17dBm	33dBm	20dBm	36dBm	22dBm	38dBm	16 dBi

Figure 1 - MicroMAX Maximum Output TX Power



Caution: Do not set maximum output TX power to higher than local regulations.

700MHz Antennas

Table 1 - 700MHz Antenna Types

Type	Frequency range	Gain	Manufacturer	Model number
V-Pol MCX	698-746 MHz	7.5 dBi	Mars Antennas	MA-WA70-AS8
Flat panel	698-746 MHz	10.5 dBi	Mti Wireless Edge Ltd.	MT-223003/N
Sector	698-746 MHz	12 ± 0.5 dBi	Mti Wireless Edge Ltd.	MT-223002/NV
Sector	698-746 MHz	13.5 dBi	Mti Wireless Edge Ltd.	MT-223006/NV
Yagi directional	698 - 746 MHz	15.3 dBi	Trival antene	AD-40/722-14



1.4 GHz Antennas

Table 2 - 1.4GHz Antenna Types

Type	Frequency range	Gain	Manufacturer	Model number
Omnidirectional	1425-1535 MHz	10 dBi	TIL-TEK	TA-1450
Omnidirectional	1425-1535 MHz	12 dBi	TIL-TEK	TA-1450-2
Panel	1425-1535 MHz	17 dBi	TIL-TEK	TA-1406
Direction Panel	1425-1535 MHz	18 dBi	Foshan Sanshui Shing Road Antenna Co.	TDJ-SA1500-18-65

2.5 GHz Antennas

Table 3 - 2.5GHz Antenna Types

Type	Frequency range	Gain	Manufacturer	Model number
V-Pol MCX	2.3 – 2.7 GHz	12 dBi	Mars Antennas	MA-WC25-AS12
Sector	2.3 – 2.7 GHz	14 dBi	Mars Antennas	MA-WC24-14
Sector	2.3 – 2.7 GHz	15.5 dBi	Mars Antennas	MA-WC24-15
Sector	2.3 – 2.7 GHz	17 dBi	Mars Antennas	MA-WC24-17

1 About this Guide

This section discusses the purpose, intended audience, conventions, referenced documentation and organization for this guide.

1.1 Purpose

This guide provides step-by-step instructions for setting up and installing the MicroMAX BSR.





The purpose of this User Guide is to provide step-by-step instructions for setting up and installing the MicroMAX BSR. These procedures include:

- System Overview
- Installation Prerequisites
- Physical descriptions
- Mounting
- Cabling
- Connecting
- Lightning and Surge Protection

1.2 Intended Audience

This guide is intended for qualified and authorized technicians who are responsible for installing the MicroMAX BSR.

1.3 Conventions

Icon	Description
	Checkpoint: Marks a point in the workflow where there may be an exit or branch to some other procedure. At each Checkpoint the reason for an exit or branch is given along with specific directions to locate the entry point in the other procedure.
	Reference: Gives a resource in the workflow that may be needed to complete a procedure along with specific directions to use the resource.
	Caution: Describes a possible risk and how to lessen or avoid the risk.
	Advice: Provides a recommendation based on best practice.
	Note: Provides useful information.

1.4 Referenced Documentation

For a description of the Web-based management tools for configuring and managing MicroMAX BSR, see the following manual:

- MicroMAX Web-based Management User's Guide
- MicroMAX Overview

2 System Overview

MicroMAX is a highly upgradeable Micro-cell base station, based on the Sequans System On a Chip (SOC), with a pole/roof (wall) mounted radio system and antennae. This high performance chip can support up to 28 + 28 MHz channels (full duplex) forms part of the AIRSPAN WiMAX portfolio of WiMAX network infrastructure equipment. It is compatible with the Airspan EasyST and ProST subscriber terminals and other manufacturer's CPEs that are fully WiMAX compliant.

The MicroMAX BSR is an outdoor radio that is mounted outside on a pole or wall. The BSR provides a wireless link with subscribers and interfaces with the provider's backbone. The MicroMAX BSR is available in two models. These models differ by antenna design (providing integral flat-panel antennas, or an N-type port for attaching third-party external antennas). MicroMAX BSR is available in numerous frequency bands, operating in FDD and TDD modes in numerous channels see: [MicroMAX Frequency Ranges](#).

The BSR connects to the indoor Ethernet switch by a CAT-5e cable, which carries the Ethernet signal, and DC power. For a MicroMAX Base Station consisting of multiple BSRs, there are two (2) options. The BSRs can be connected to individual Subscriber Data Adapters (SDA-4S) or to Base Station Distribution Units (BSDU). For a Base Station consisting of a single BSR, the BSR typically connects to a single Subscriber Data Adapter (SDA-4S or SDA-4SDC).

MicroMAX BSR provides a low cost, high-performance point-to multipoint packet-based Broadband Wireless Access (BWA) solution. MicroMAX BSR Provides wireless connectivity designed to deliver high-speed data, voice over IP (VoIP) and multimedia services to residential, SOHO (Small Office/Home Office), and SME (Small to Medium Enterprises).

The MicroMAX is an encased outdoor radio providing access to the MicroMAX's communication ports on its bottom panel. The MicroMAX's back panel provides holes for mounting.

MicroMAX BSR interfaces with the service provider's backbone through either:

- The SDA-4S Type II or the SDA-4SDC (referred henceforth as SDA-4S) integrated LAN switches.
 - SDA-4S Type II: integrated LAN switch, providing power and four 10/100BaseT ports for interfacing with the subscriber's network
 - SDA-4SDC Type II: integrated LAN switch, providing power and four 10/100BaseT interfaces and especially designed for implementation where available power supply is DC (10 to 52 VDC), e.g. from a solar panel. This model provides regulated -48 VDC power to the BSR.
- **Base Station Distribution Unit (BSDU)** - provides an interface between multiple BSRs and the service provider's backbone.

MicroMAX can be managed by an SNMP-based network management system (Netspan) using standard and proprietary MIBs. In addition, external third-party management systems such as HP OpenView can also manage the MicroMAX using these MIBs. Basic management can be performed using any standard Web browser.



Note: For management refer to MicroMAX Web Management documentation.

2.1 MicroMAX Frequency Ranges

The table below lists the frequency range of MicroMAX models currently available. This table will grow as more models become available.

Table 4 - MicroMAX Frequency Ranges

Frequency Band	Channel Bandwidth
698 – 746 MHz in TDD mode	<ul style="list-style-type: none"> ➤ 2.5 MHz ➤ 5 MHz ➤ 10 MHz
1.42 - 1.52 GHz in TDD mode	<ul style="list-style-type: none"> ➤ 1.5 MHz ➤ 1.75 MHz ➤ 2.5 MHz ➤ 5 MHz
2.5 – 2.69 GHz in TDD mode NPI	<ul style="list-style-type: none"> ➤ 2.5 MHz ➤ 5 MHz ➤ 10 MHz
2.7 – 2.9 GHz in TDD mode NPI	<ul style="list-style-type: none"> ➤ 3 MHz ➤ 6 MHz ➤ 10 MHz
3.3 - 3.5 GHz in TDD mode	<ul style="list-style-type: none"> ➤ 1.75 MHz ➤ 2.75 MHz ➤ 3 MHz ➤ 3.5 MHz ➤ 5 MHz
3.4 - 3.5 GHz in FDD mode/ 50MHz	<ul style="list-style-type: none"> ➤ 1.75 MHz ➤ 3.5 MHz ➤ 5 MHz *
3.4 - 3.6 GHz in FDD mode (Lo, Hi)	<ul style="list-style-type: none"> ➤ 1.75 MHz ➤ 3.5 MHz
3.4 - 3.6 GHz in TDD mode	<ul style="list-style-type: none"> ➤ 1.75 MHz ➤ 3.5 MHz ➤ 5 MHz
3.6 - 3.8 GHz in FDD mode (Lo, Hi)	<ul style="list-style-type: none"> ➤ 1.75 MHz ➤ 3.5 MHz
3.6 - 3.8 GHz in TDD mode	<ul style="list-style-type: none"> ➤ 1.75 MHz ➤ 3.5 MHz ➤ 5 MHz ➤ 7 MHz



Frequency Band	Channel Bandwidth
4.9 - 5.0 GHz in TDD mode	<ul style="list-style-type: none">➤ 2.5 MHz➤ 5 MHz➤ 10 MHz
5.15 - 5.35 GHz in TDD mode	<ul style="list-style-type: none">➤ 2.5 MHz➤ 5 MHz➤ 10 MHz
5.47 - 5.725 GHz in TDD mode	<ul style="list-style-type: none">➤ 2.5 MHz➤ 5 MHz➤ 10 MHz
5.725 - 5.875 GHz in TDD mode	<ul style="list-style-type: none">➤ 2.5 MHz➤ 5 MHz➤ 10 MHz
5.85 - 5.95 GHz in TDD mode	<ul style="list-style-type: none">➤ 2.5 MHz➤ 5 MHz➤ 10 MHz

* As long as the central channel is an even number

2.2 System Components

- Outdoor - Unit(s):
 - MicroMAX Base Station Radio(s) (BSR)
 - Global Positioning System (GPS)
- Indoor:
 - SDA-4S Type II: small low cost IDU with built in LAN switch
 - SDA-4SDC Type II: small low cost DC IDU with built in LAN Switch
 - GPSD: optional Global Positioning System Distribution unit (for up to 4 BSRs)
 - BSDU: optional Ethernet switch for implementing Base Stations consisting of multiple BSRs
- IDU/ODU connectivity:
 - CAT-5e cable 24 gauge or better (22 gauge recommended) for connecting to BSR (SFTP - Shielded Foiled Twisted Pair - recommended)
 - Fast Ethernet: 4 pins
 - VDC power: BSR FDD/TDD requires 2 pins
 - IDU/ODU length for BSR FDD: up to 100 meters
- Minimum configuration:
 - SDA-4S and a single BSR
- Larger configurations:
 - N*SDA-4Ss and N*BSRs



- N*BSRs and BSDU (up to 8 BSRs per unit)
- Optional AC/DC power converter - in the event -48 VDC is not available at BS site

2.3 Customer Benefits

The MicroMAX BSR offers the following customer benefits:

- Based on the latest wireless technology WiMAX IEEE 802.16 2004 standard
- SOC engine for best cost/performance
 - Based on Sequans "System On a Chip" (SOC)
 - high performance chip
 - high growth potential

2.4 Architecture

The MicroMAX system consists of the following component designs:

- Integrated Antenna Design
 - Encased MicroMAX BSR outdoor unit with integrated antenna
 - SDA-4S Type II or SDA-4SDC Type II indoor unit
 - GPSD (optional for up to 4 BSRs)
 - BSDU (optional for multiple BSRs)
 - GPS antenna utilized with BSDU
 - External AC/DC power converter (optional)
- External Antenna Design
 - Encased MicroMAX BSR outdoor unit
 - SDA-4S Type II or SDA-4SDC Type II indoor unit
 - BSDU (optional for multiple BSRs)
 - GPS antenna utilized with BSDU or GPSD unit
 - Third-party external antenna (optional deployment)
- External AC/DC power converter (optional)

The figures below displays a typical setup (using BSDU) of the MicroMAX(s) mounted outdoors on a pole (with an integrated antenna).

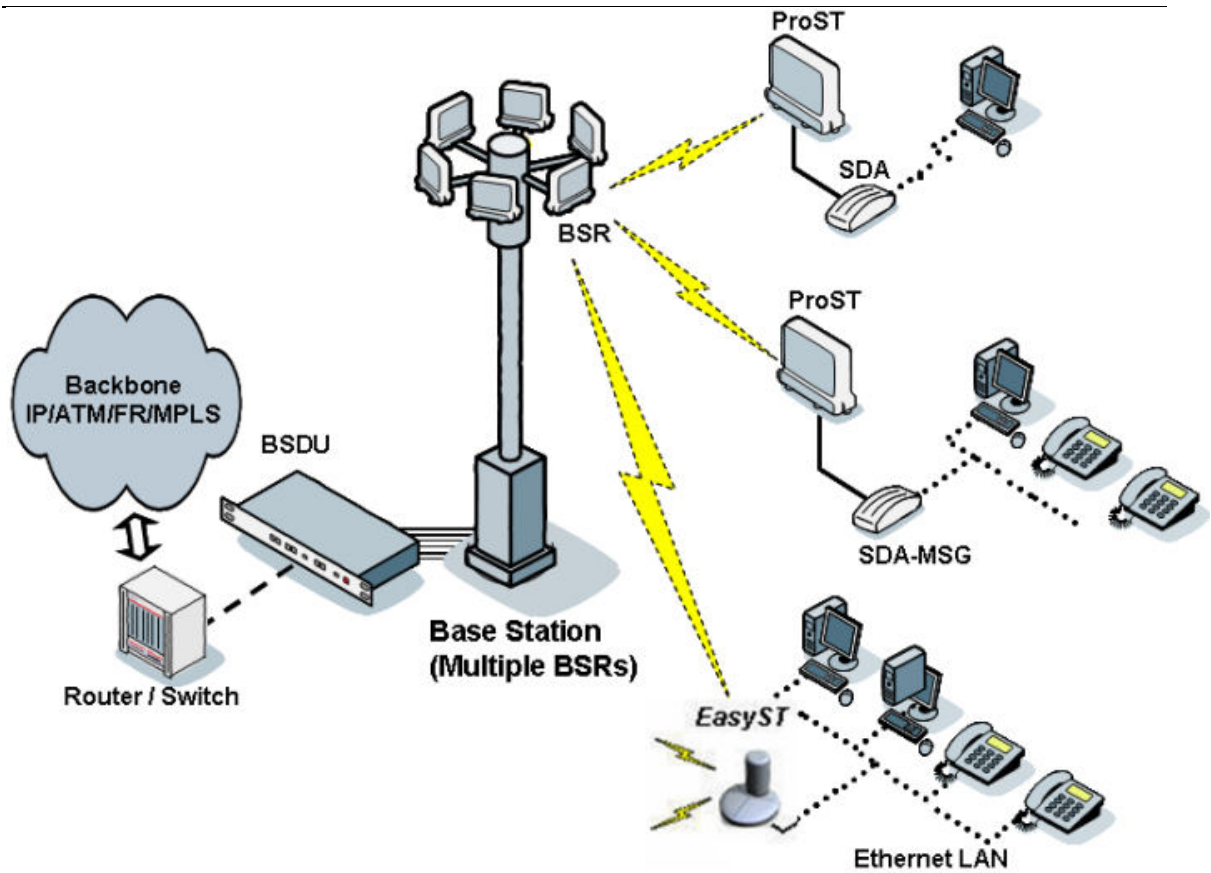

Figure 2 - Typical Setup

2.5 Power

- The SDA-4S is a switch providing the MicroMAX BSR with -48 VDC power supply, and 10/100BaseT interface with the subscriber's PCs/network.
- The BSDU is also responsible for providing BSRs with -48 VDC power supply and for synchronizing BSDUs, BSRs and Base Stations (when a GPS is implemented).
- An external AC/DC power converter (optional) is available in the event -48 VDC is not available at BS site. Contact your Airspan supplier.

2.6 Models

The MicroMAX is available in the following basic physical designs:

- MicroMAX with a built-in (integral), internal antenna.
- MicroMAX with an N-type type RF connector for connecting an optional third-party external antenna.



Note: A MicroMAX with an N-type port for attaching a third-party external antenna does not provide a built-in antenna.



3 Installation Prerequisites

Before installing your MicroMAX, review:

- [Package Contents](#)
- [Required tools](#)
- [Radio Site planning](#)

3.1 Package Contents

Examine the AIRSPAN WIMAX shipping container. If you notice any damage, or missing items as listed in the Packing List, immediately notify the carrier that delivered the unit and contact a Airspan representative.

The MicroMAX kit should contain the following items:

- MicroMAX Base Station radio
- DB15-to-RJ45 adapter for plugging into the BSR's 15-pin D-type port
- Pole-mounting kit:
 - 2 x M10 hex head screws
 - 2 x M10 flat washers
 - 2 x M10 spring lock washers
 - 2 x M10 hex nuts
 - Mounting bracket
 - 2 x M6 hex head screws
 - 2 x M6 spring lock washers
 - Clamping bracket
 - 2 x M8 'U'- bolts
 - 4 x M8 hex nuts
 - 4 x M8 plain washers
 - 4 x M8 spring lock washers

The GPSD (optional) kit should contain the following items:

- GPSD (AC or DC)
- Power cable – for AC
- GPS antenna
- 4 “Y” cables

The GPS kit should contain the following items:

- GPS Smart Antenna RS422
- Conn DB15PM AMP - for discrete wires IDC
- Connector, Circular (Deutsch IMC26-2212X) - Industrial Micro 12P F
- Cable 4x2422# (CAT-5e) - 10 meters
- 8x Contact sockets (for Deutsch 6862-20122278) - Circular Micro connectors
- Boot shrink w/ glue (Raychem) - heat shrink
- Plastic Hood 15-Pin - D-Type sub-connector



Note: The standard MicroMAX kit does not include wall-mounting accessories. For pricing and ordering of wall-mounting accessories, please contact your nearest Airspan dealer.

3.2 Required Tools

The following tools are required to install the MicroMAX unit:

- Torque wrench for N-type connectors (only relevant when implementing external antenna)
- Cable stripping tool
- 10-mm, 13-mm, and 17-mm A/F open ended spanners

3.3 Radio Site Planning

Proper site selection and planning before installing your MicroMAX will ensure a successful deployment of your AIRSPAN WIMAX system. A summary of the main site planning considerations is provided below:

- Minimum obstructions (e.g. buildings) in the radio path between base station and the subscriber terminals.
- Mount radio as high as possible to avoid obstructions in the wireless path.
- Check possibility of future obstructions such as plans to erect buildings and trees that may grow tall enough to obstruct the wireless path.
- Align radio for maximizing received signal strength (RSS).
- Consider nearby sources of interference that could degrade performance of radio.
- Mount radio as far from sources of interference as possible.
- Ensure base station and subscriber terminals (i.e ProST/EasyST) are within maximum coverage range of reception.
- Maximum standard CAT-5e cable length connecting the MicroMAX to the indoor SDA-4S or BSDU is 100 meters.
- Ensure that you have sufficient wiring conduit and cable ties to channel and protect the CAT-5e cable connecting the outdoor MicroMAX to the indoor SDA-4S.

3.3.1 Radio Antenna Alignment

ProST

Once the subscriber unit (i.e. ProST) is installed and aimed in the general direction of the BSR, it is recommended to measure the received signal strength (RSS) to determine the signal strength received from the BSR, and to precisely align the ProST for maximum signal strength.

You need to orientate (up/down, left/right) the ProST until the maximum RSSI levels are achieved, and then secure the ProST.

EasyST

Once the subscriber unit (i.e. EasyST) is installed and aimed in the general direction of the BSR, simply move the EasyST to the position that gives optimal reception.

4 Physical Description

This section provides a description of the components of the MicroMAX installation:

- MicroMAX (outdoor unit)
- SDA-4S Type II (indoor unit)
- SDA-4SDC Type II (indoor DC unit)

4.1 MicroMAX BSR

The BSR is an encased outdoor radio providing access to communication ports on its bottom panel. The BSR's back panel provides holes for mounting.

4.1.1 Physical Dimensions

The table below lists the physical dimensions of the BSR.

Table 5 - BSR Dimensions

Parameter	Value	Comment
Height	400 mm (15.74 inches)	The physical dimensions exclude the mounting kit.
Width	317 mm (12.48 inches)	
Depth	65.5 mm (2.58 inches)	
Weight	3.8 kg	

The figure below illustrates the MicroMAX's physical dimensions.

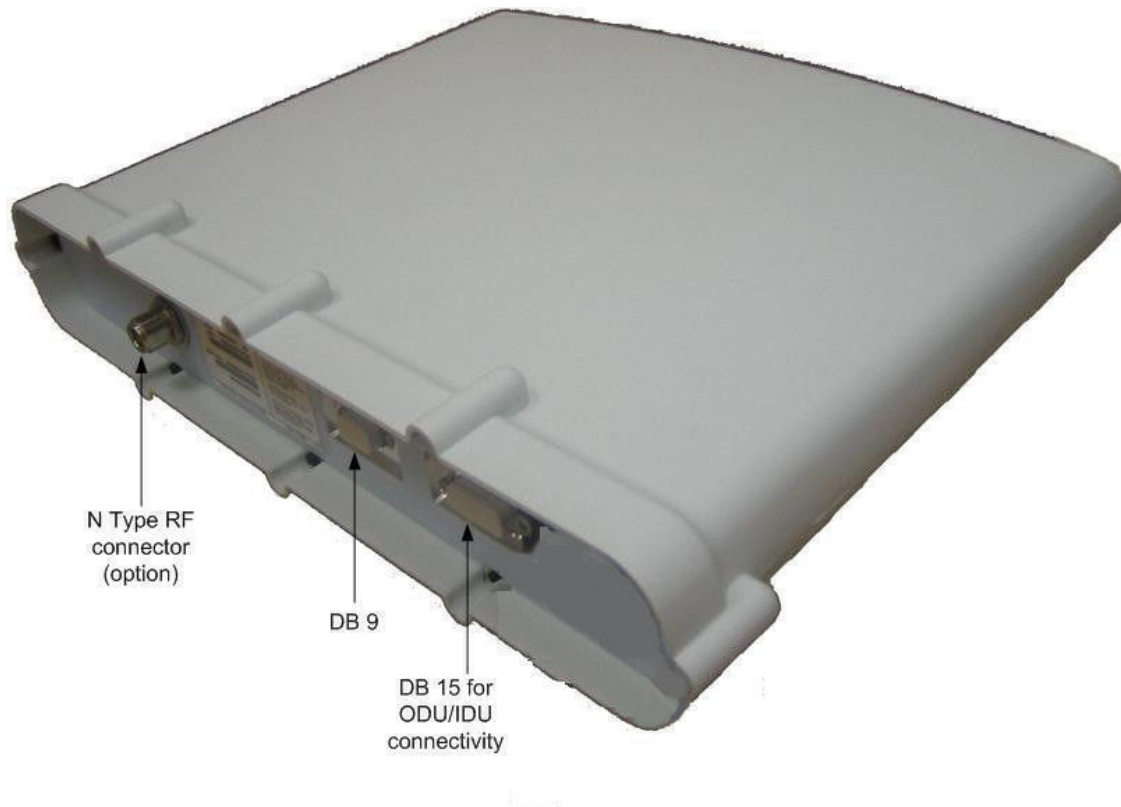

Figure 3 - BSR ports



Note: BSR models that use third-party external antennas provide an N-type receptacle for attaching an external antenna.

4.1.2 Ports

The table below defines the different ports on the bottom panel.

Table 6 - BSR ports

Port interfaces	Description
DB 15	IDU/ODU interface: <ul style="list-style-type: none"> ➤ Fast Ethernet from/to SDA-4S or SDA-4SDC Type II and BSDU ➤ Power from SDA-4S Type II or SDA-4SDC Type II and BSDU ➤ TDD Tx/Rx sync from BSDU
DB 9	Engineering applicability (Technical Service only)
N Type RF connector - relevant when implementing external antenna	External antenna connection



Note: Some previous models (still in use) have an RJ45 port with cover which has been discontinued as of December 2006.

MicroMAX is powered from the indoor integrated LAN switch:



Note: The SDA-4S Type II and the SDA-4SDC are physically (externally) the same other than the power socket.

4.2 SDA-4S Type II

The SDA-4S Type II indoor unit (hereafter referred to as SDA-4S) is an integrated LAN switch, providing power and four 10/100BaseT ports for interfacing with the subscriber's network. The unit is displayed in the figure below.

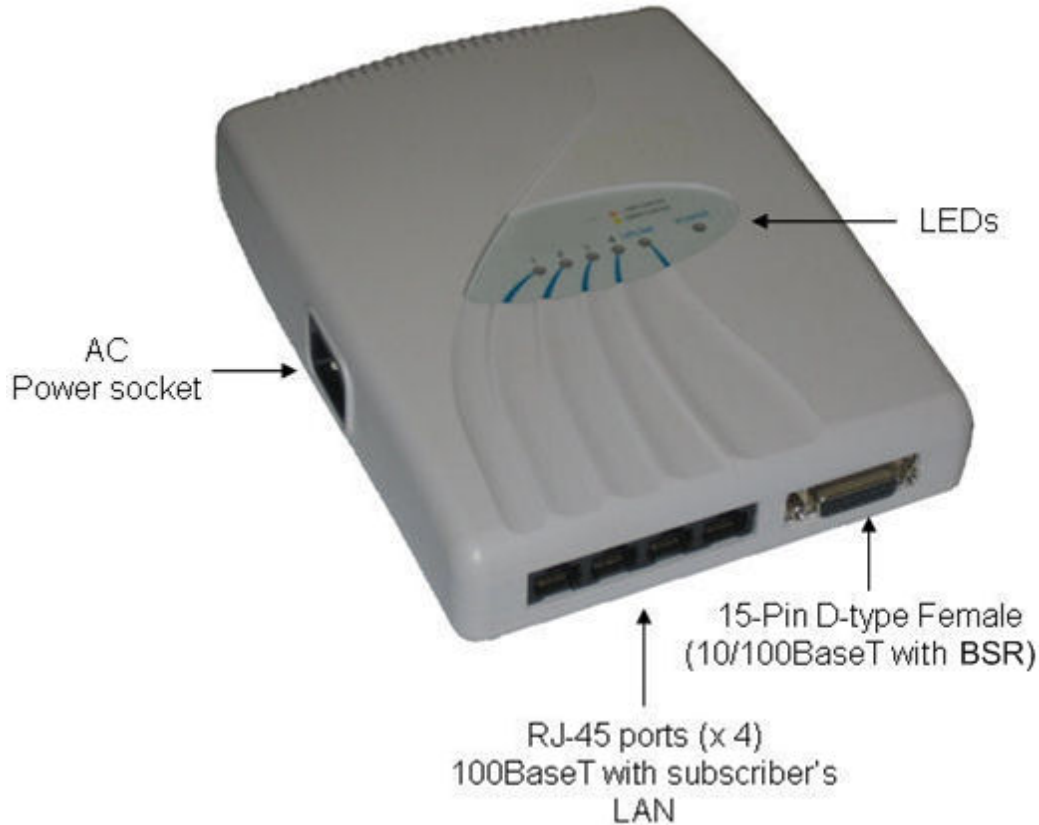

Figure 4 - SDA-4S Type II

This subsection provides the following SDA-4S physical descriptions:

- [Dimensions](#)
- [Ports](#)
- [LEDs](#)

4.2.1 Physical Dimensions

The SDA-4S physical dimensions are described in the table below:

Table 7 - SDA-4S dimensions

Parameter	Value
Dimensions	Height - 200mm (7.87 inches) Width - 150mm (5.9 inches) Depth - 40mm (1.57 inches)
Weight	0.53 Kg

4.2.2 Ports

The SDA-4S adapter provides ports on the front panel, which are described in the table below:

Table 8 - SDA-4S ports

Port	Interface
4 x 8-pin RJ-45	10/100BaseT with subscriber's network (supports Auto Negotiation and MDI/MDI-X automatic crossover, allowing connection of straight-through or crossover cables)
15-pin D-type (female)	10/100BaseT with BSR
AC power socket	Subscriber's power outlet (110-240 VAC, 1A, 50/60 Hz, 50W)



Note: The ports of the SDA-4S models support Auto Negotiation, allowing automatic configuration for the highest possible speed link (10BaseT or 100BaseT), and Full Duplex or Half Duplex mode. In other words, the speed of the connected device (e.g. PC) determines the speed at which packets are transmitted through the specific SDA-4S port. In addition, the SDA-4S ports support MDI/MDI-X automatic crossover, allowing connection to straight-through or crossover cables.

4.2.3 LEDs

The LEDs description is the same as for the SDA-4SDC below.

4.3 SDA-4SDC Type II

The SDA-4SDC Type II indoor unit is an integrated LAN switch, providing power and four 10/100BaseT ports for interfacing with the subscriber's network and especially designed for implementation where available power supply is DC. This model provides regulated –48 VDC power. The unit is displayed in the figure below.

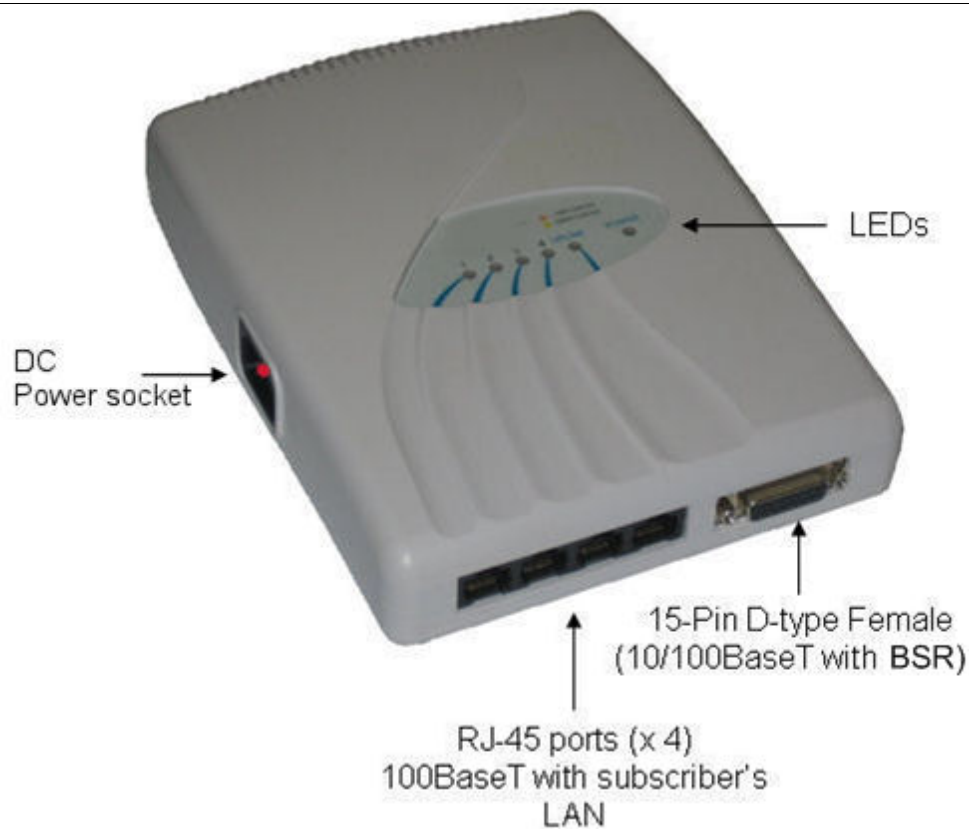

Figure 5 - SDA-4SDC Type II

This subsection provides the following SDA-4SDC physical descriptions:

- [Dimensions](#)
- [Ports](#)
- [LEDs](#)

4.3.1 Physical Dimensions

The SDA-4SDC physical dimensions are described in the table below:

Table 9 - SDA-4SDC dimensions

Parameter	Value
Dimensions	Height - 200mm (7.87 inches) Width - 150mm (5.9 inches) Depth - 40mm (1.57 inches)
Weight	0.53 Kg

4.3.2 Ports

The SDA-4SDC adapter provides ports on the front panel, which are described in the table below:

Table 10 - SDA-4SDC ports

Port	Interface
4 x 8-pin RJ-45	10/100BaseT with subscriber's network (supports Auto Negotiation and MDI/MDI-X automatic crossover, allowing connection of straight-through or crossover cables)
15-pin D-type (female)	10/100BaseT with BSR
DC power socket	DC power outlet (10-52 VDC, 24W)

4.3.3 LEDs

The SDA-4S (all types) adapter provides LED indicators on the top panel, which are described in the table below:

Table 11 - SDA-4S LEDs

LED	Color	Status	Description
UPLINK	Yellow (100BaseT) or Orange (10BaseT)	On	Physical link (10BaseT or 100BaseT) between SDA-4S adapter and BSR
		Blinking	Traffic currently flowing between SDA-4S and BSR
		Off	No link between SDA-4S and BSR
1, 2, 3, 4	Yellow (100BaseT) or Orange (10BaseT)	On	Physical link (10BaseT or 100BaseT) between SDA-4S and subscriber's Ethernet network
		Blinking	Traffic currently flowing between SDA-4S and subscriber's Ethernet network
		Off	No link between SDA-4S and subscriber's Ethernet network
POWER	Green	On	Power received by SDA-4S
		Off	No power received by SDA-4S

The figure below displays the LEDs which are located on the top panel of the SDA-4S adapter:

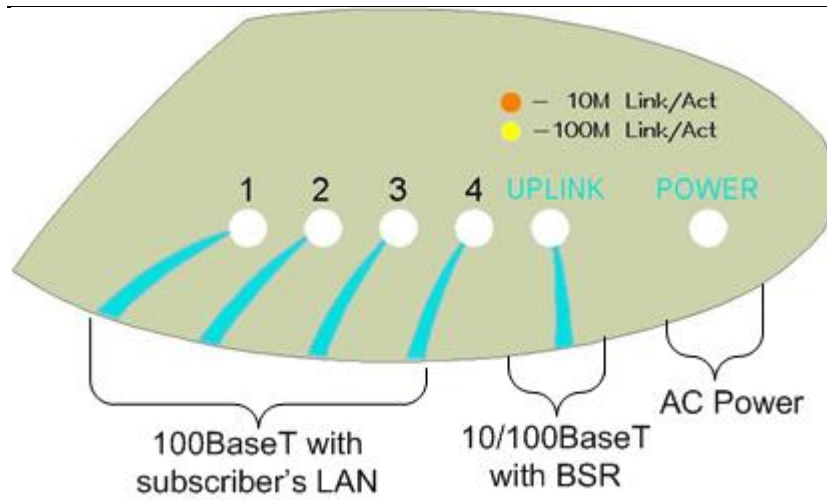

Figure 6 - SDA-4S top panel

5 BSDU Description

This section provides a description of the **Base Station Distribution Unit (BSDU)**.

The BSDU is connected to the BSRs by standard CAT-5e cables. Each BSDU can service a maximum of 8 BSRs. In addition, up to two BSDUs can be daisy-chained at a Base Station, supporting up to 16 BSRs. Therefore, a Base Station at maximum configuration can serve up to 8192 subscribers (i.e. 16 BSRs multiplied by 512 subscribers).

The BSDU provides a 15-pin D-type port for interfacing with the BSRs, for convenience, a DB15-to-RJ45 adapter is supplied for attaching to the 15-pin D-type port to allow the use of RJ-45 connectors for outdoor-to-indoor CAT-5e cable connectivity.

The AIRSPAN WIMAX Base Station Distribution Unit (BSDU) provides an interface between multiple MicroMAX (BSRs) and the service provider's backbone. The BSDU provides the following functionalities:

- Data switching and aggregation:
 - Data switching between up to eight MicroMAX BSRs over 10/100 BaseT interface.
 - Aggregate the MicroMAX BSRs data via two 1000BaseT Ethernet (GE) ports towards the backhaul/backbone or to cascade to another BSDU.
- Synchronization:
 - Tx / Rx TDD synchronization for multiple MicroMAX BSRs per BSDU and between connected BSDUs.
 - GPS for TDD Tx / Rx synchronization of different BS sites.
- Power distribution
 - Provides DC power from a single -48 VDC source to eight MicroMAX BSRs.
 - AC/DC power converter (optional) - in the event -48 VDC is not available at BS site.



Note: The unit should be powered by -48Vdc (40-54Vdc), 4.5A from safety approved power supply that its output is SELV and is separated from mains by minimum double/reinforced insulation.

5.1 Physical Dimensions

The table below lists the physical dimensions of the BSDU.

Table 12 - BSDU dimensions

Parameter	Value	Comment
Height	43.2 mm (1.7 inches)	The physical dimensions exclude the bracket flanges for mounting.
Width	482.6 mm (19 inches)	
Depth	228.6 mm (9 inches)	
Weight	2.9 kg	

The figure below illustrates the BSDU's physical dimensions.



Figure 7 - BSDU front

5.2 Ports

The BSDU provides various hardware interfaces on its front and rear panel as described in the tables and figures below.

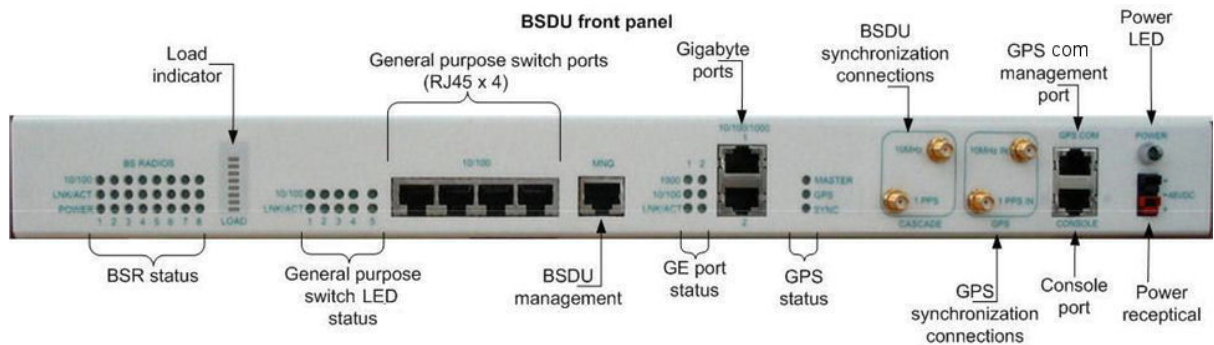

Figure 8 - BSDU Front Panel

The following table lists the front panel hardware interfaces (refer to the front panel figure):

Table 13 - Front Panel Interfaces

Port	Label	Interface
8-pin RJ-45 (4)	10/100	4 x 10/100 BaseT general purpose switch
8-pin RJ-45	MNG	10/100 BaseT for out-of-band management
8-pin RJ-45 (2)	10/100/1000 1 / 2	1 - Interface with provider's backbone 2 – Daisy-chained BSDUs, interface with another BSDU for cascading
SMA (2)	GPS 10MHz IN & 1PPS IN	Interface with GPS for global clock synchronization by means of 2 signals: 10 MHz and 1 PPS For future use
SMA (2)	CASCADE 10MHz & 1PPS	Interfaces with a daisy-chained BSDU for cascading the 2 GPS signals For future use
8-pin RJ-45	GPS COM	Interfaces with the GPS serial port for getting status and alarms
8-pin RJ-45	CONSOLE	BSDU serial port for initial configuration
Power Receptacle	-48VDC	-48 VDC supply from external feeding source

The BSDU provides LEDs for indicating the status of various operations. The LEDs are located on the front panel. The LEDs colors are green with 3 optional states: Off, On and Flashing. The following table details the LEDs functionality:

Table 14 - BSDU LEDS description

LED	Status	Description																		
BSR Status <u>10/100</u> (1–8)	On	BSR is connected when the link is On (100 Base-T)																		
	Off	BSR is connected when the link is On (10 Base-T)																		
BSR Status <u>LNK/ACT</u> (1–8)	On	Physical link exists between BSDU and BSR																		
	Flashing	Ethernet activity detected on BSR port																		
	Off	No physical link exists between BSDU and BSR																		
BSR Status <u>Power</u> (1–8)	On	Power supplied to BSDU's BSR port																		
	Off	BSDU's BSR port is disabled by software, or port failure has occurred																		
Load Indicator 8 levels of On	The Traffic Load Bar indicates 8 traffic levels via 8 LEDs:																			
	<table border="1"> <thead> <tr> <th>No. of LEDs</th> <th>Utilization</th> </tr> </thead> <tbody> <tr> <td>1</td> <td>0.4%</td> </tr> <tr> <td>2</td> <td>0.8%</td> </tr> <tr> <td>3</td> <td>1.6%</td> </tr> <tr> <td>4</td> <td>3.2%</td> </tr> <tr> <td>5</td> <td>6.4%</td> </tr> <tr> <td>6</td> <td>12.8%</td> </tr> <tr> <td>7</td> <td>25%</td> </tr> <tr> <td>8</td> <td>Over than 50%</td> </tr> </tbody> </table>		No. of LEDs	Utilization	1	0.4%	2	0.8%	3	1.6%	4	3.2%	5	6.4%	6	12.8%	7	25%	8	Over than 50%
	No. of LEDs	Utilization																		
	1	0.4%																		
	2	0.8%																		
	3	1.6%																		
	4	3.2%																		
	5	6.4%																		
	6	12.8%																		
7	25%																			
8	Over than 50%																			
General Purpose Switch <u>LNK/ACT</u> (1–5)	On	Viable physical link between the 10/100 Base-T port and the external device to which this port connects																		
	Flashing	Ethernet activity detected on 10/100 Base-T port																		
	Off	No physical link between 10/100 Base-T port and external device to which this port connects																		
General Purpose Switch <u>10/100</u> (1–5)	On	The link between the general purpose switch port and the external device is synchronized with a rate of 100 Base-T																		
	Off	The link between the general purpose switch port and the external device is synchronized with a rate of 10 Base-T																		
GE Ports Status <u>Backhaul / Cascade</u> <u>LNK/ACT</u> (1–2)	On	Viable physical link between the 10/100/1000 Base-T port towards the backhaul or the daizy-chained BSDU																		
	Flashing	Ethernet activity detected on 10/100 Base-T port																		
	Off	No physical link between the 10/100/1000 Base-T port towards the backhaul or the daizy-chained BSDU																		

LED	Status	Description
GE Ports Status Backhaul / Cascade 10/100 (1-2)	On	The link between the GE port and the backhaul or the daizy-chained BSDU is synchronized with a rate of 100 Base-T
	Off	The link between the GE port and the backhaul or the daizy-chained BSDU is synchronized with a rate of 10 Base-T
GE Ports Status Backhaul / Cascade 1000 (1-2)	On	The link between the GE port and the backhaul or the daizy-chained BSDU is synchronized with a rate of 1000 Base-T
	Off	The link between the GE port and the backhaul or the daizy-chained BSDU is not synchronized with a rate of 1000 Base-T
GPS Status Master	On	Master provides the GPS clock source in case of BSDUs cascading
	Off	Slave gets the GPS clock from the Master BSDU in case of BSDUs cascading
GPS Status GPS	On	GPS is connected
	Off	No GPS is connected
GPS Status SYNC	Flashing	When the GPS sync pulse is received
	Off	No GPS sync pulse
Power	On	Indicates whether the BSDU gets the -48 VDC from external source

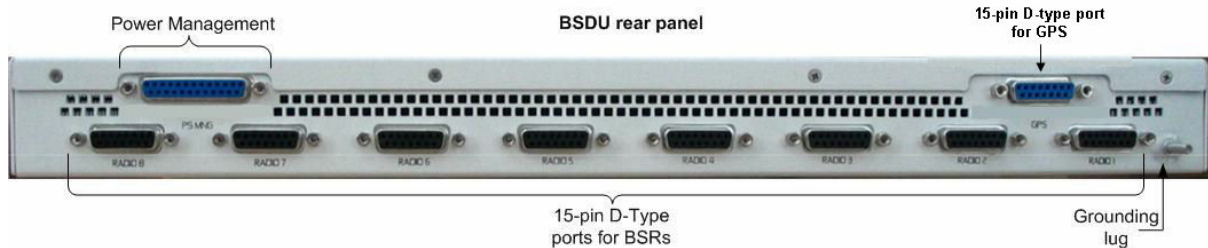

Figure 9 - BSDU Rear Panel

The following table lists the rear panel hardware interfaces (refer to the rear panel figure):

Table 15 - Rear panel Interfaces

Port	Label	Interface
15-pin D-type female (8)	BSR 1 – BSR 8	Provides 10/100 Base-T (Ethernet),synchronization and 48 VDC power feed interfaces with BSRs
25-pin D-type female	External Power Supply	For external Power Supply (AC/DC) management
15-pin D-type female (1)	GPS	Global Positioning System (GPS)-based synchronization

6 GPSD Description

This section provides a description of the **Global Positioning System Distribution unit (GPSD)** (Optional). The GPSD distributes GPS synchronization to up to 4 BSRs.

The GPSD unit is a, self-contained GPS Distribution unit and is available in 2 models, either in 10 to 52 VDC or in 110-240 VAC, 1A, 50/60 Hz, 50W. The GPSD is an optional unit that connects up to four (4) SDA-4S (or SDA-4SDCs).

Table 16 - GPSD Voltage & Currency Ratings

Models	Ratings
AC	110-240 VAC, 0.25A
DC	10-52 VDC, 1A



Note: The DC unit should be powered by a limited power source of up to 3A.

The GPSD incorporates two (2) connections for different GPS connections. There is an SMA connection for use with the included external GPS antenna which works in conjunction with the internal GPS module. The internal GPS synchronizes multiple (up to 4) Base Stations, ensuring that the entire network operates with the same clock based on a universal satellite clock signal.

There is also a 15-PIN D-Type connection for use with a third-party GPS antenna. The GPSD, external antenna and “Y” cable are displayed in the figures below:



Figure 10 – GPSD



Note: Service personnel must install the AC unit connected to a properly grounded outlet.



Note: To reduce the risk of fire only no.26 AWG or larger telecommunication line cord should be used.



Figure 11 - External antenna (included)



Note: The supplied external antenna is limited to 5 meters long.

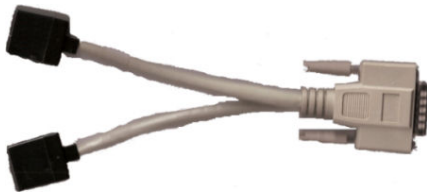

Figure 12 - "Y" cable (4 included)

This section provides the following GPSD physical descriptions:

- [Dimensions](#)
- [Ports](#)
- [LEDs](#)

6.1 Physical Dimensions

The GPSD physical dimensions are described in the table below:

Table 17 - GPSD dimensions

Parameter	Value
Dimensions	Height - 200mm (7.87 inches) Width - 150mm (5.9 inches) Depth - 40mm (1.57 inches)
Weight	0.53 Kg

6.2 Ports

The GPSD adapter provides ports on the front panel, which are described in the table below:

Table 18 - GPSD ports

Port	Interface
4 x 8-pin RJ-45	10/100BaseT with subscriber's BSRs (up to 4).
15-pin D-type (female)	For connection to external GPS antenna for SYNC from the GPS and power to the GPS.
4 x "Y" cables	Split – supplies power & data from SDA-4S(DC) and SYNC from GPSD. <div style="text-align: center;">  <p>Note: Cables are clearly labeled "MicroMAX" and "GPSD". The RJ45 Jacks are clearly labeled "MicroMAX" and "GPSD".</p> </div>
AC power socket	Subscriber's power outlet (110-240 VAC, 1A, 50/60 Hz, 50W)
OR	
DC power socket	DC power outlet (10-52 VDC, 24W)

6.3 LEDs

The GPSD provides LED indicators on the top panel, which are described in the table below:

Table 19 - GPSD LED description

LED	Color	Status	Description
SYNC	Orange	On	When the board is in reset (normally will blink for 200ms when power ON - Power on reset).
	Green	Blinking	When receiving 1PPS from the GPS blinks 1 second for 300-400 ms
		Off	No PPS was received from the GPS
Power	Green	On	Appropriate power is being fed to the unit
		Off	No power

The figure below displays the LEDs which are located on the top panel of the GPSD:

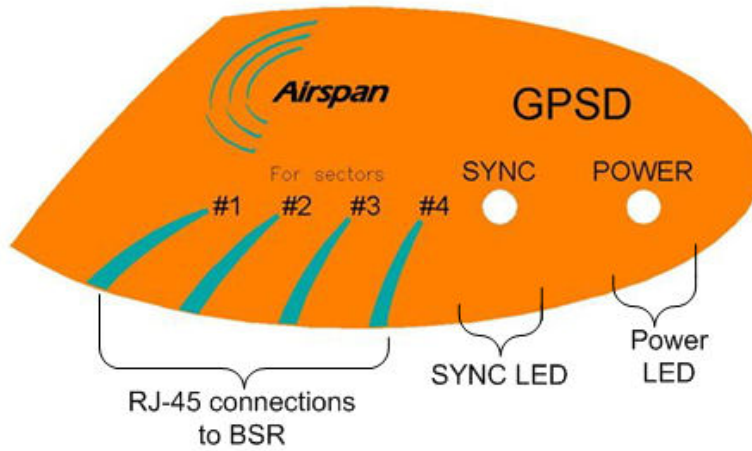

Figure 13 - GPSD top panel

6.4 Mounting the GPSD

The GPSD is mounted vertically on a wall in the communication center within connection distance of the SDA-4S(s) it services. Wall mounting is made possible by the existence of two mounting hooks molded into the GPSD's bottom panel, as displayed in the figure below.



Figure 14 - Wall mount

To wall mount the GPSD:

On the wall, mark the position of the two mounting hooks. The dimensions of the wall-mounting hooks are displayed in the template below.

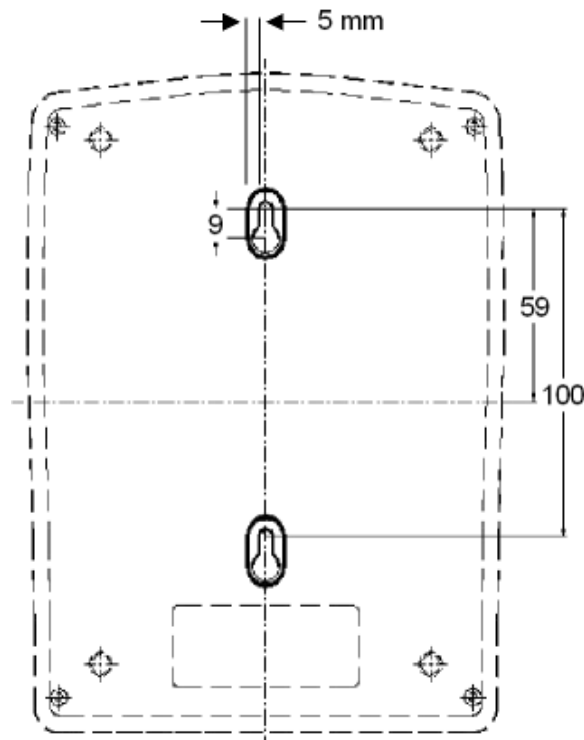

Figure 15 - mounting template

1. Drill holes for each hole that you marked in the step above.
2. Insert wall anchors (supplied) into each of the drilled holes.
3. Insert the 9-inch screws (supplied) into the wall anchors. Ensure at least 2 mm of the screw is exposed to allow insertion into the GPSD mounting holes.
4. Hold the GPSD with both hands, and align the entrance to the two mounting hooks with the screws. Slide the screws into the mounting hooks, by lowering the GPSD onto the screws.



Note: For safety, both mounting hooks must be utilized when mounting the unit.



Note: The GPSD is supplied with a 1-metre AC power lead assembly. Therefore, ensure the unit is mounted within reachable distance to the customer's mains power outlet.



Note: The maximum cable run between GPSD and MicroMAX is 100 meters. Therefore, ensure the unit is mounted within reachable distance.

6.5 GPSD Architecture

The figures below display a typical setup, using the GPSD, multiple BSR(s), multiple SDA-4S or SDA-4SDC, “y” cable and the GPS antenna.



Note: Alternately you can use the supplied external antenna which is limited to 5 meters long.

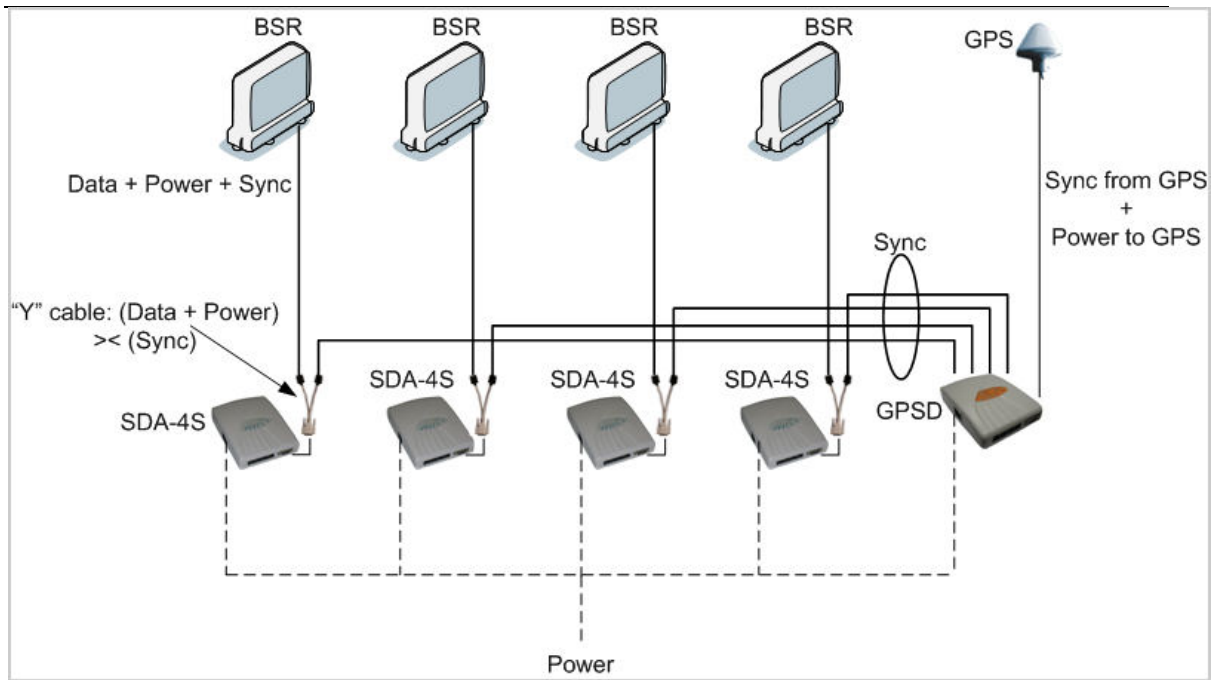

7 GPS Description

This section provides a description of the **Global Positioning System (GPS)**.



Note: Even if there is a single isolated BS with multiple sectors the GPS is required.

The third-party GPS antenna is a rugged, self-contained GPS receiver and antenna that receives a universal GPS satellite clock signal. The GPS connects to the BSDU. The GPS synchronizes (based on frequency hopping) multiple Base Stations, ensuring that the entire Airspan WiMAX network operates with the same clock based on a universal satellite clock signal. This is crucial in eliminating radio frequency ghosting effects.



Figure 16 - GPS antenna

7.1 Physical Dimensions

The GPS physical dimensions are described in the following table.

Table 20 - GPS dimensions

Parameter	Value
Diameter	5.91" (15.0 cm)
Height	6.5" (16.5 cm)
Weight	684g (1.51 lb)

The figure below illustrates the GPS's physical dimensions.

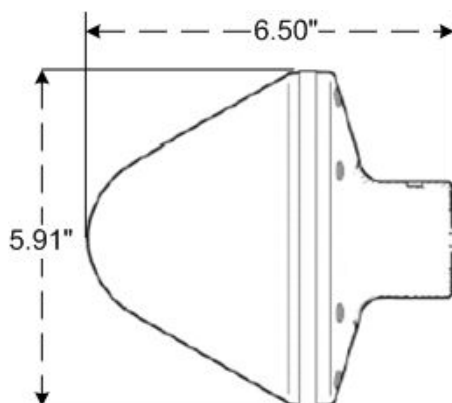

Figure 17 - GPS dimensions

7.2 Ports

The GPS provides 12-pin male contacts for connecting a cable between it and the BSDU.

GPS Connector- Female

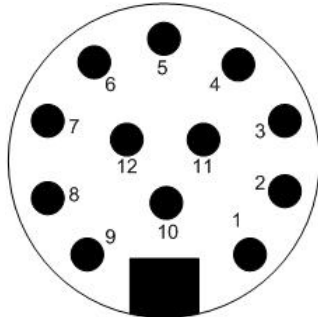

Figure 18 - GPS pinouts

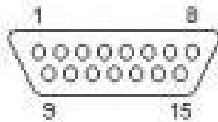

Figure 19 - Db-15

The connectors' pinouts are described in the following table; connections should be as defined.

Table 21 - GPS Pinouts

Db-15 Connector	GPS connector	Description (GPS side)
13	1	Power +
6	2	Receive -
5	3	Receive +
4	4	Transmit -
3	5	Transmit +
--	6(NC)	
--	7(NC)	
--	8(NC)	
12	9	Power -
	10(NC)	
7	11	PPS+
8	12	PPS-

7.3 Crimping GPS Cable

The third-party Global Positioning System antenna (GPS) connects to the BSDU's 15-pin D-type port. Therefore, the cable from the GPS needs to be crimped to a 15-pin D-type male connector.

Airspan recommends using the *Daniels AFM8 (M22520/2-01)* crimping tool for crimping the GPS cable to 15-pin D-type connectors.

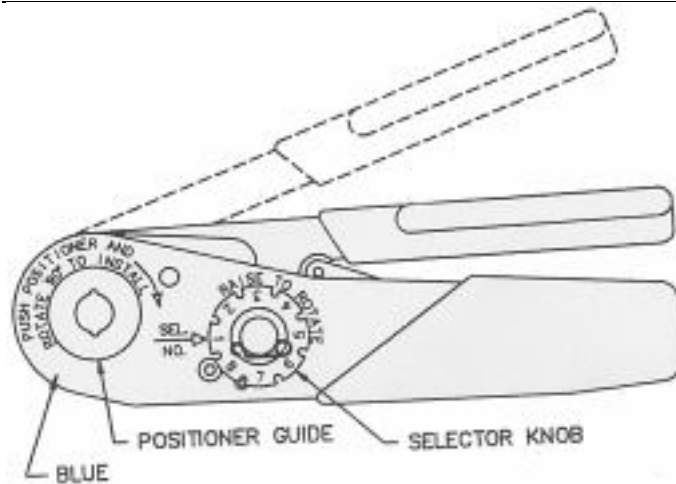

Figure 20 - Crimping tool (Daniels AFM8)

Once you have housed the stripped cable, you can now crimp the cable to 15-pin D-type connector.



Note: The crimper cannot be opened without completing the cycle.

To crimp the GPS's cable:

1. Ensure that the crimper is in the open position.
2. Remove safety clip from positioner guide.
3. Select the Positioner for contact to be crimped.
4. Insert the Positioner into the positioner guide and turn it 90 degrees until bayonet pins lock.
5. Raise and rotate the Selector knob until the number indicated on data plate for cable size to be crimped is in line with **Sel. No.** arrow.
6. Insert the contact and prepared cable into the indenter opening from the side opposite the Positioner.
7. Squeeze crimper handles together until the ratchet releases. The handle will return to the open position.
8. Remove crimped contact and cable

7.4 Contact Socket Crimping

The discrete crimping method crimps each wire individually (from the CAT-5e cable) to a Contact socket (there are 8). The contact sockets are then inserted into the Circular connector housing.

The following table lists the specifications of the discrete contact crimping.

Table 22 - Contact socket crimping

Parameter	Description	Part
Crimping tool	Hand crimp tool for single contacts	Crimping tool
Connector	Circular Connector	Industrial Micro 12P F (Deutsch IMC26-2212X)
Contact	Contact socket	For Circular Micro connector

The figure below displays the crimping tool used in the contact socket crimping.



Figure 21 - Contact crimp tool

To crimp CAT-5e cable using discrete contact crimping method:

1. Strip 50 mm of the cable's sheath.
2. Strip 3 to 4 mm of each wire to expose their strands.
3. Insert the contact socket on the crimper's left side such that the contact socket's opening is pointing upwards, the end of the contact socket is flush with the crimper on the left side, and the contact socket end stands out on the right side.

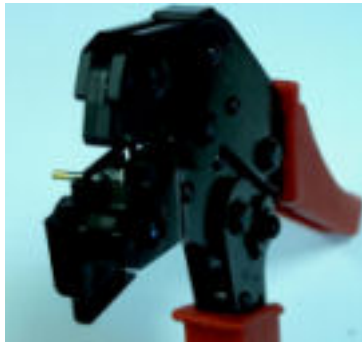

Figure 22 - Inserting socket into crimper

4. Place the wire in the contact socket's opening. The exposed wire must be placed in the contact socket's opening.
5. Squeeze the crimper handles to crimp the contact socket over the wire.
6. Remove the crimped contact socket and crimp the remaining wires.
7. When all the wires have been crimped, insert the crimped contact sockets into the rear of the Circular connector housing, in their correct order according to the connector pinouts (defined above).

8 AC/DC Power Converter

This section provides a description of the external **AC/DC Power converter** - Optional.

The third-party external AC/DC Power Converter is an optional unit that connects to the BSDU in the event there is no -48VDC availability at the Base Station site (110/220 input). The AC/DC Power Converter chassis fitted with one PS Unit for BSDU (PC-BSDU-1) supports up to 8 BSRs. An additional PS unit is available (optional) for redundancy.

The figure below illustrates the AC/DC Power Converter's physical dimensions.



Figure 23 - AC/DC Power Converter

8.1.1 Physical Dimensions

The AC/DC power converter physical dimensions are described in the following table.

Table 23 - AC/DC power converter dimensions

Parameter	Value	Comment
Height	43.2 mm (1.7 inches)	The physical dimensions exclude the bracket flanges for mounting.
Width	482.6 mm (19 inches)	
Depth	228.6 mm (9 inches)	

8.2 Redundant PS Unit

The RPSU-BSDU-1 is a redundant PS Unit for the BSDU AC/DC power converter. The power factor corrected (PFC) front ends provide a 48 VDC output for distributed power applications. The small 1U by 2U size allows for configurations of either height in hot-swap redundant systems while its internal fan and cooling design permits wide use with reliable operation.

The figure below illustrates the redundant PS Unit.

Figure 24 - RPSU-BSDU-1



9 Mounting the Base Station Radio (BSR)

The MicroMAX BSR can be pole-mounted or wall-mounted (optional). Pole mounting allows the BSR to be easily adjusted in the horizontal (azimuth) and vertical (elevation) planes for antenna alignment.

For either mounting method, the MicroMAX provides mounting holes (displayed in the figure below), molded into its back panel for attaching the mounting brackets.



Note: The BSR fully complies with IP Code - IPX6 for product enclosure protection.



Warning: The BSR device is an outdoor radio unit, and therefore, must only be mounted outside.



Warning: Warning: Mount the MicroMAX in an orientation such that its ports (located on the bottom panel) faces downwards. This prevents rain water from settling on the ports, and thereby, avoiding damage to the unit such as corrosion and electrical short-circuiting.

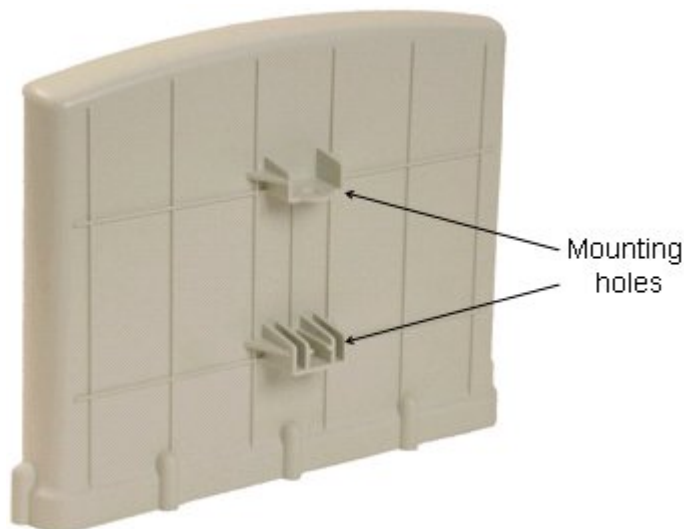

Figure 25 - BSR- rear view



Note: The standard BSR kit provides pole-mounting brackets. If you want to wall-mount the MicroMAX, contact your Airspan distributor for pricing and ordering of wall-mounting brackets.

9.1 Pole-Mounting the BSR

Pole mounting allows the MicroMAX to be easily adjusted in the horizontal (azimuth) and vertical (elevation) planes for antenna alignment. The BSR is mounted using the mounting holes located on the BSR's back panel and the supplied pole-mounting brackets. The pole-mounting bracket is designed to support the BSR on a round pole of 45 mm in diameter.

The figure below summarizes of the MicroMAX's pole-mounting procedure.

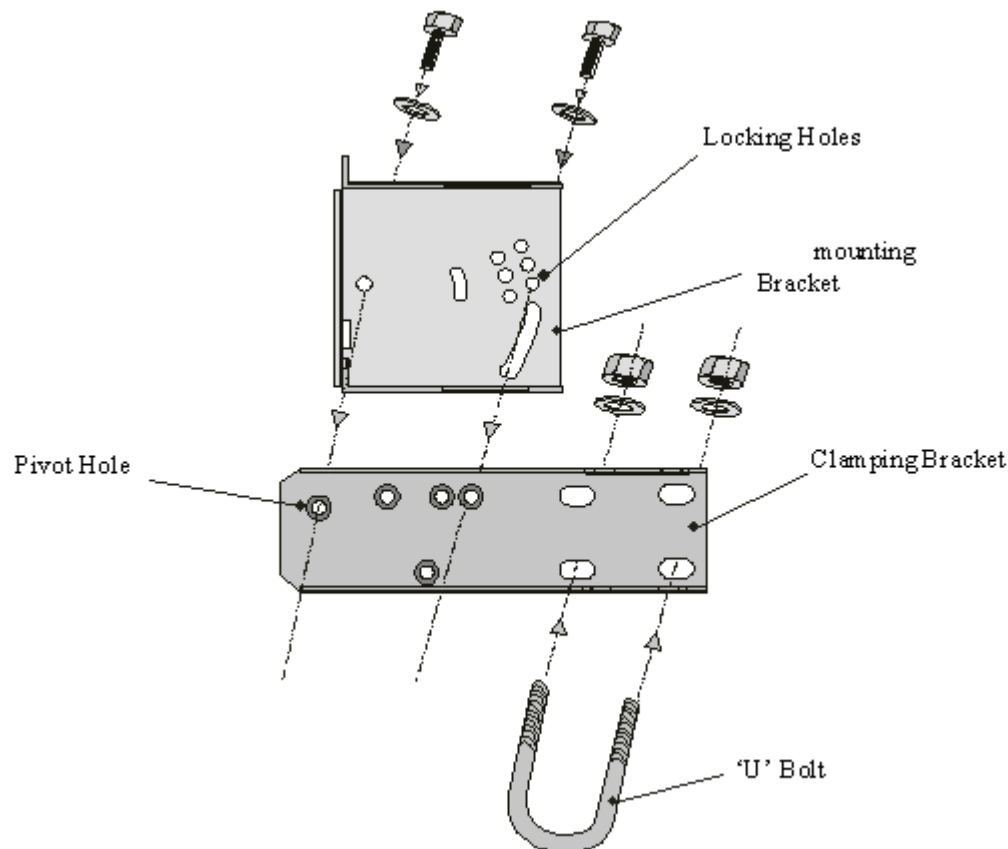

Figure 26 - Pole mounting bracket

To pole mount the MicroMAX BSR:

8. Attach the mounting bracket to the MicroMAX:
 - a. Align the mounting bracket with the MicroMAX's mounting holes so that the mounting bracket's side with the built-in nut is aligned with the BSR's mounting holes furthest from the MicroMAX's bottom panel, as shown in the figure below.
 - b. Slide an M10-flat washer and M10-spring lock washer onto an M10-hex head screw (ensure spring lock washer is closest to the bolt's head). From the external side, insert the M10-hex head screw through the mounting bracket and MicroMAX's mounting holes. Fasten the M10-hex head screw (one is provided with a built-in nut while the other requires you to insert an M10-hex nut into the MicroMAX's mounting hole). After alignment is completed, tighten bolts. Max torque for M10 is 44Nm (32lbf.ft.).

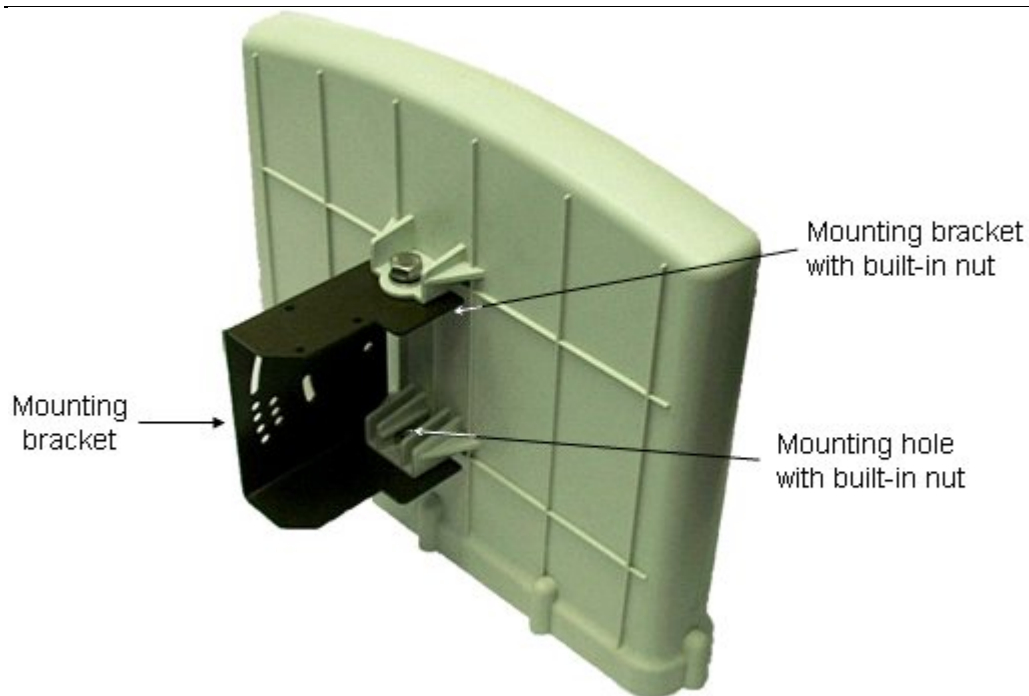

Figure 27 - Mounting bracket attached

9. Attach the clamping bracket to the mounting bracket:
 - a. Slide an M6-spring lock washer onto an M6-hex head screw. Align the mounting bracket's and clamping bracket's pivot holes, such that the clamping bracket is aligned to the inside of the mounting bracket. From the external side of the mounting bracket, insert the M6-hex head screw into the pivot holes and then fasten, but not tightly. (The clamping bracket provides a built-in nut.)
 - b. Choose an elevation hole on the mounting bracket and then align it with the corresponding hole on the clamping bracket. Slide an M6-spring lock washer onto an M6-hex head screw, and then from the external side of the mounting bracket, insert the M6-hex head screw through the elevation hole on the mounting bracket and into the clamping bracket's corresponding hole. Fasten but not tightly the M6-hex head screw (the clamping bracket provides built-in nut). The elevation hole can later be changed according to desired antenna orientation in the elevation plane.

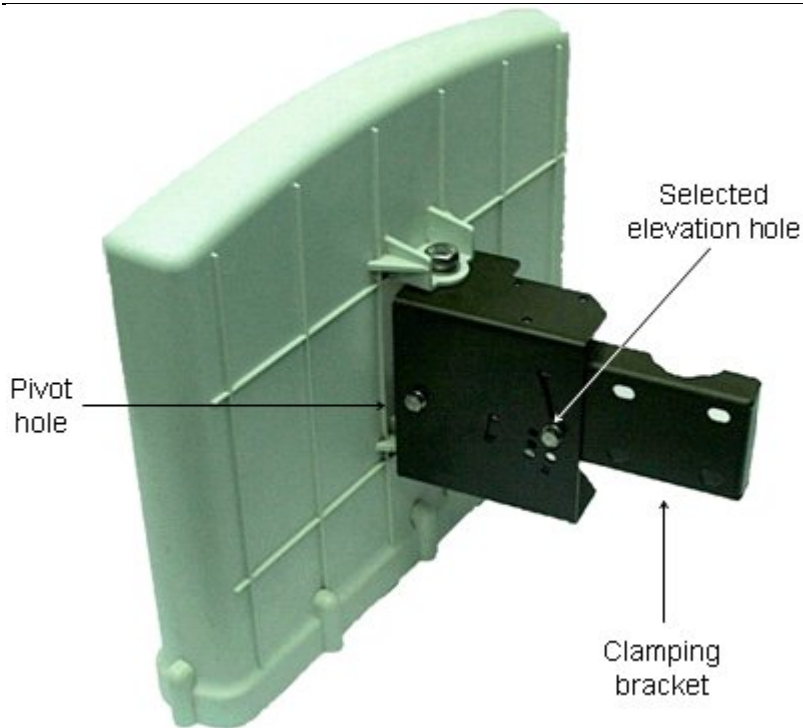

Figure 28 - Pole mount clamping bracket

10. Attach the U-bolt to the pole:
 3. Place one U-bolt around the pole, and then insert the U-bolt screw side through the two corresponding holes (horizontally parallel) on the clamping bracket. Slide an M8-flat washer and M8-spring lock washer onto each U-bolt screw side (ensure that the flat washer is adjacent to the clamping bracket). Fasten each U-bolt side with the two M8-hex nuts.
 - d. Attach the second U-bolt as described above.

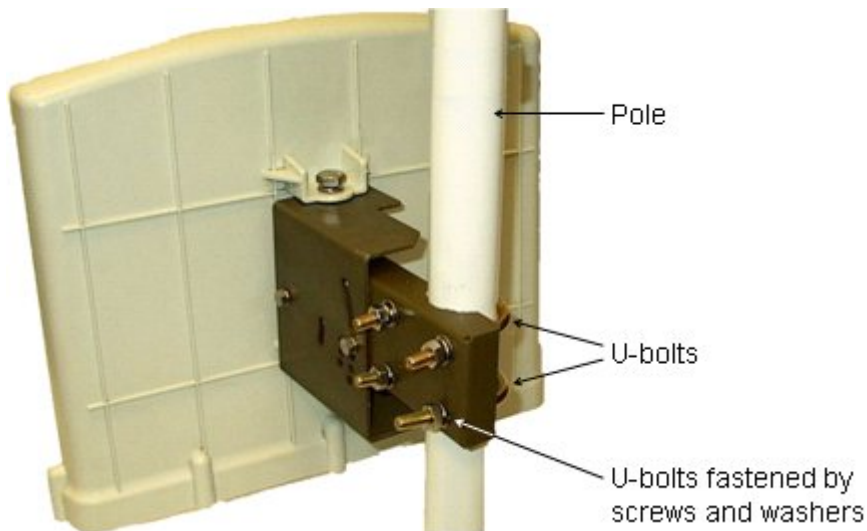

Figure 29 - Pole mount U-bolts

11. Perform final MicroMAX orientation:
 - a. Adjust the vertical position of the MicroMAX by choosing a final elevation hole as described in Step 2. Lock the MicroMAX at the desired position by inserting the locking bolt in the desired position and fastening it tightly. Fasten tightly the bolt in the pivot hole. The figure below illustrates the angles (in degrees) of each elevation hole. As shown, the MicroMAX pole-mounting bracket allows elevation between -18.5° and 26.3° .

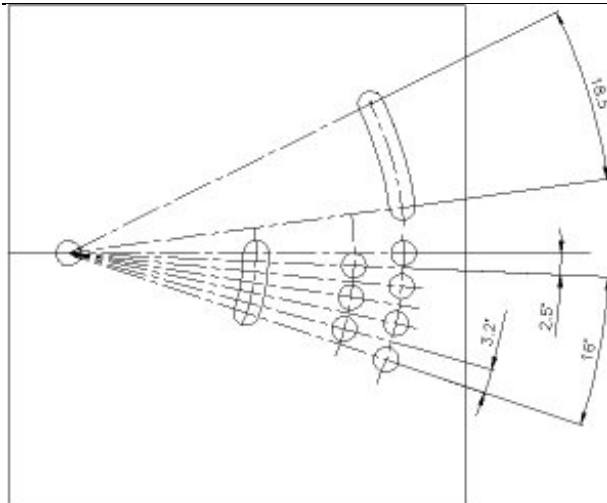

Figure 30 - elevation holes

- b. Adjust the horizontal position of the MicroMAX by rotating it about the pole, and then tightening the nuts of the U-bolts.



Note: A thread-locking compound must be used to prevent the bolts from working loose.

MicroMAX positioning is obtained in two planes by adjustment of the mounting bracket assembly as shown below.

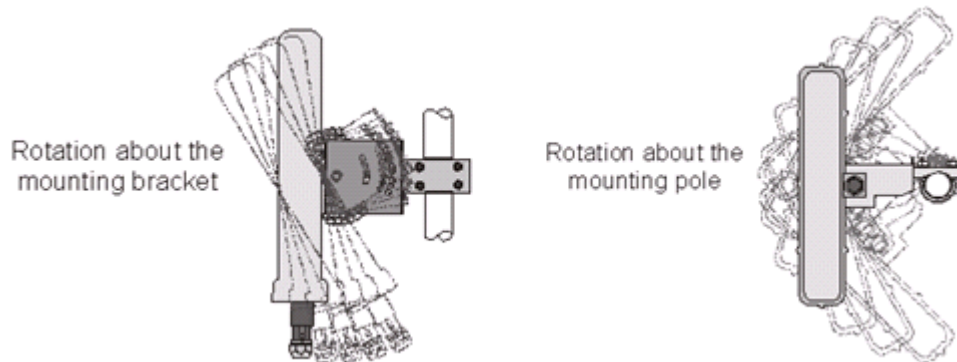

Figure 31 – positioning

It is important to provide strain relief and drip loop for Cat-5 cables. Create a drip loop and strain relief using cable tie, to tie cable to pole, as displayed in the figure below:



Figure 32 - strain relief

9.2 Wall-Mounting the BSR (Optional)



Note: The standard BSR kit provides pole-mounting brackets. If you want to wall-mount the MicroMAX BSR contact your Airspan distributor for pricing and ordering of wall-mounting brackets.



Note: A minimum of 3 meter separation is required between MicroMAX and existing customer radio equipment.



Note: A minimum of 1 meter separation should be maintained between synchronized MicroMAXs (see figure below).

The figure below illustrates the minimum separation between synchronized MicroMAX's :

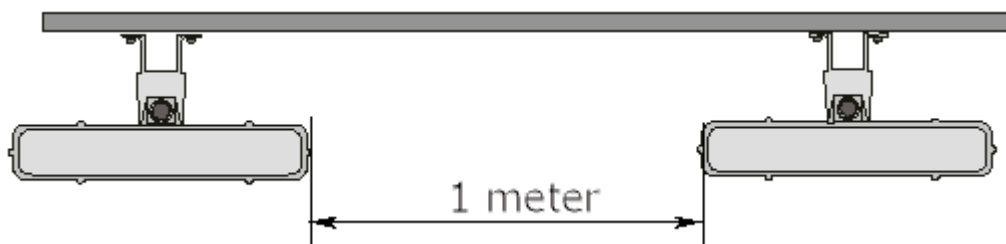

Figure 33 - mount separation

MicroMAX wall mounting consists of two main stages:

- Attaching the mounting bracket to the MicroMAX's mounting holes
- Attaching the mounting bracket (already attached to the MicroMAX) to the wall (or pole)

To wall mount the MicroMAX:

1. Position the unassembled mounting bracket on the mounting surface (e.g. wall), and then use a pencil to mark the position of the four mounting holes. Ensure that the distance between the hole centers are 120 mm (height) and 60 mm (width), as displayed in the figure below showing the MicroMAX's fixing dimensions.

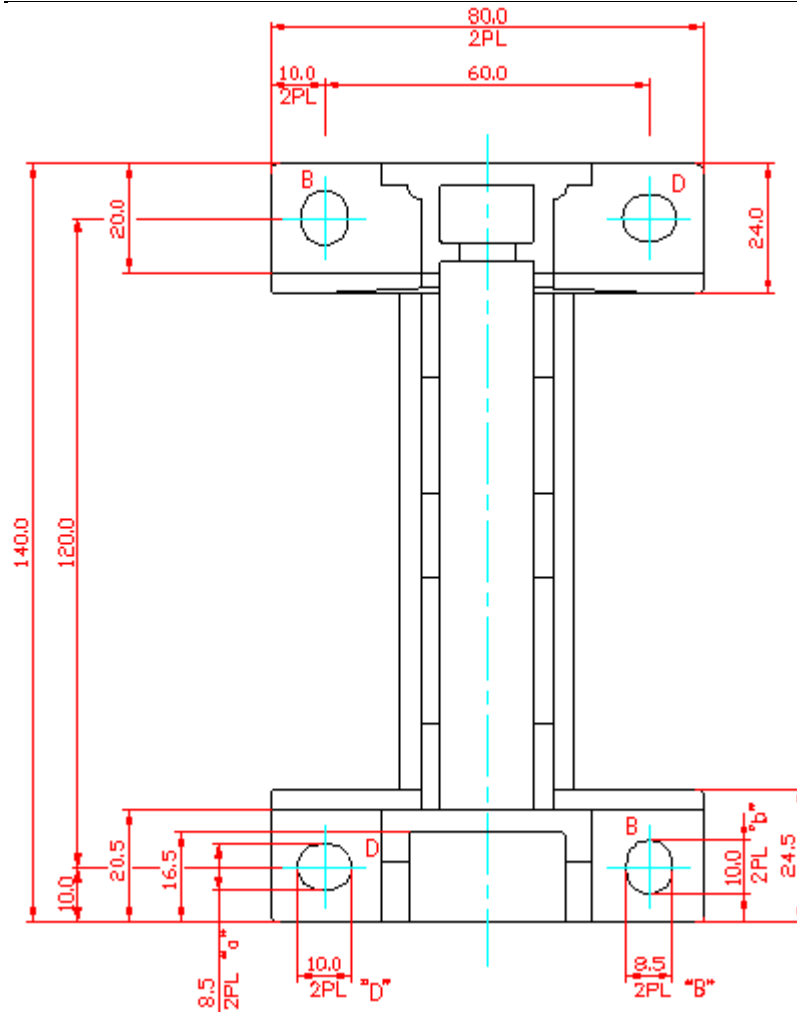

Figure 34 - mounting template

2. Drill holes for each hole that you marked in the step above.
3. Insert wall anchors (not supplied) into each of the drilled holes.
4. Align the mounting bracket's four holes with the wall anchors, and then insert a screw (not supplied) through the mounting bracket holes into each wall anchor, and then tighten.



Note: Airspan does not provide screws for attaching the mounting bracket to the wall. The screw size depends on the structure of the building to which the bracket is to be attached. When selecting screw sizes, consideration must be given to the weight of the MicroMAX and load that may be induced in windy conditions.

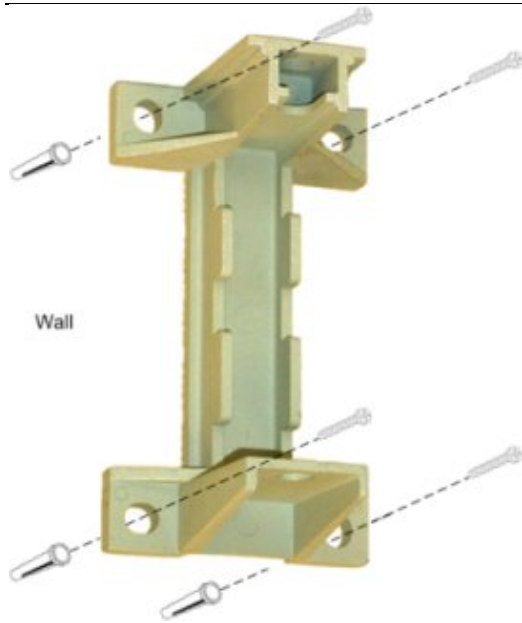

Figure 35 - wall-mount bracket

5. Attach the MicroMAX to the mounting bracket by performing the following:
 - a. Slide an M10-spring lock washer and then an M10-plain washer onto each M10 x 1.5 hex head screw (20mm length) – (ensure lock washer is nearest to head of screw bolt).
 - b. Align the mounting bracket's holes with the MicroMAX's mounting holes as displayed below. (The mounting bracket side that provides a groove for inserting a nut must be aligned with the MicroMAX's mounting hole that is nearest to the MicroMAX's bottom panel.)
 - c. From the external sides, insert the M10-hex head screws through the mounting bracket's holes and MicroMAX's mounting holes. Loosely fasten with the M10-hex nuts.

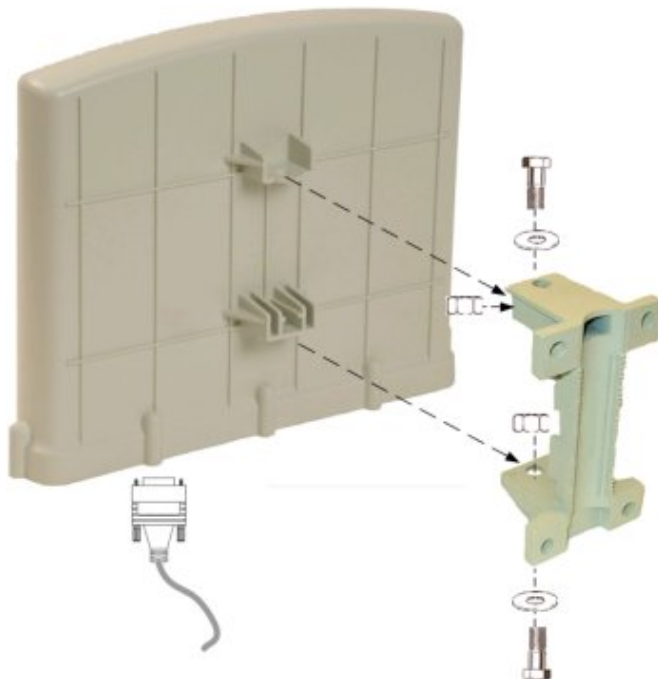

Figure 36 - attach mounting bracket

5. Adjust the horizontal positioning of the MicroMAX (see "Web-Based Management" for MicroMAX antenna alignment using RSS measurements), and then tighten the two M10 x 1.5-hex head screws (20mm length) with the M10 hex nuts.



Note: A third-party thread-locking compound must be applied to the M10-hex head screws to prevent the bolts from working loose.



Note: For wall mounting, rotation is restricted in the horizontal plane only.

9.3 Installing the SDA-4S

The SDA-4S Type II (or SDA-4SDC Type II) is mounted vertically on a wall within the communication center.

9.3.1 Wall Mounting

Wall mounting is made possible by the existence of two mounting hooks molded into the SDA-4S's bottom panel, as displayed in the figure below.



Figure 37 - wall mount

To wall mount the SDA-4S:

On the wall, mark the position of the two mounting hooks. The dimensions of the wall-mounting hooks are displayed in the template below.

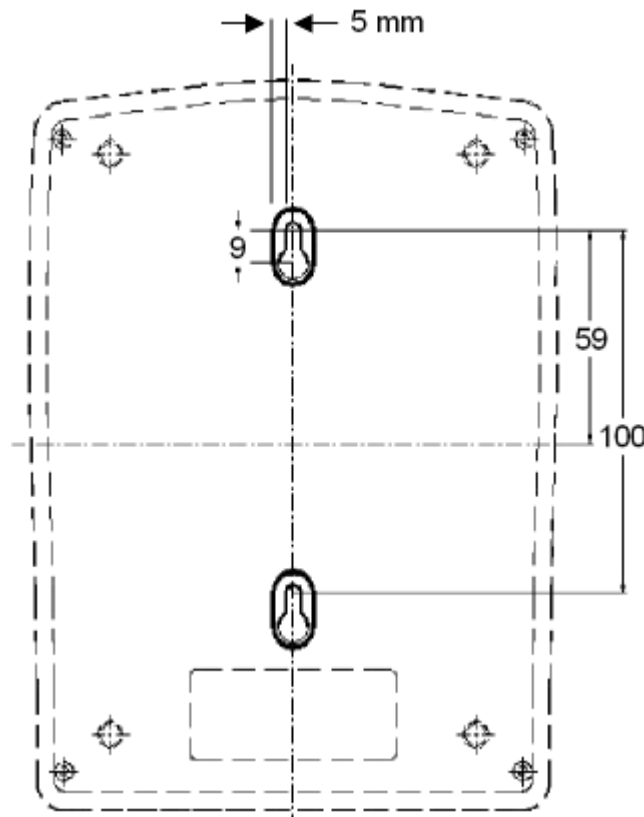

Figure 38 - SDA-4S mounting template

6. Drill holes for each hole that you marked in the step above.
7. Insert wall anchors (supplied) into each of the drilled holes.
8. Insert the 9-inch screws (supplied) into the wall anchors. Ensure at least 2 mm of the screw is exposed to allow insertion into the SDA-4S mounting holes.
9. Hold the SDA-4S with both hands, and align the entrance to the two mounting hooks with the screws. Slide the screws into the mounting hooks, by lowering the SDA-4S onto the screws.



Note: For safety, both mounting hooks must be utilized when mounting the unit.



Note: The SDA-4S is supplied with a 1-metre AC power lead assembly. Therefore, ensure the unit is mounted within reachable distance to the customer's mains power outlet.



Note: The maximum cable run between SDA-4S and MicroMAX is 100 meters. Therefore, ensure the unit is mounted within reachable distance.

10 Mounting the BSDU

The BSDU can be mounted in either of the two (2) following ways:

- Horizontally on a desktop
- Horizontally in a rack (ETSI or 19")

10.1 Desktop mounting

The BSDU can simply be placed horizontally on a table. You can attach to the BSDU's bottom panel, four rubber feet (pads) (supplied) on each corner to provide cushioning and insulation from static electricity.



Warning: To prevent a fire hazard caused by overheating, do not place the BSDU on a surface where airflow is restricted.

10.2 Rack mounting

The BSDU is designed for mounting in a standard 19-inch (48.3 cm) ETSI equipment rack or telco rack with 1-rack unit (1-U) of vertical rack space. Mounting bracket flanges are provided for mounting the BSDU into the cabinet, in its kit. Therefore, all that is required for mounting the BSDU is to attach the BSDU front-rail mounting brackets to the rack's mounting rails using the supplied four M5-mounting screws and plastic cup washers.

To rack-mount the BSDU:

1. Determine the rack rail holes (left and right side) that will be used for attaching the chassis.
2. Insert four nuts into the rack's rail holes you designated in Step 1. These nuts are housed in Tinnerman clips, which allow you to fasten them into the rail holes. To insert the Tinnerman clips, hold the clips, squeeze them, and then insert them into the rail hole.
3. Carefully insert the BSDU into the rack, aligning the BSDU's mounting bracket holes with the rack rail holes.
4. Insert the M5-mounting screws, with plastic washers, into the BSDU mounting bracket holes, on each side, as shown in figure below. In this way, the chassis is supported until you tighten the chassis screws.
5. Tighten the M5-mounting screws to fasten the chassis to the cabinet.

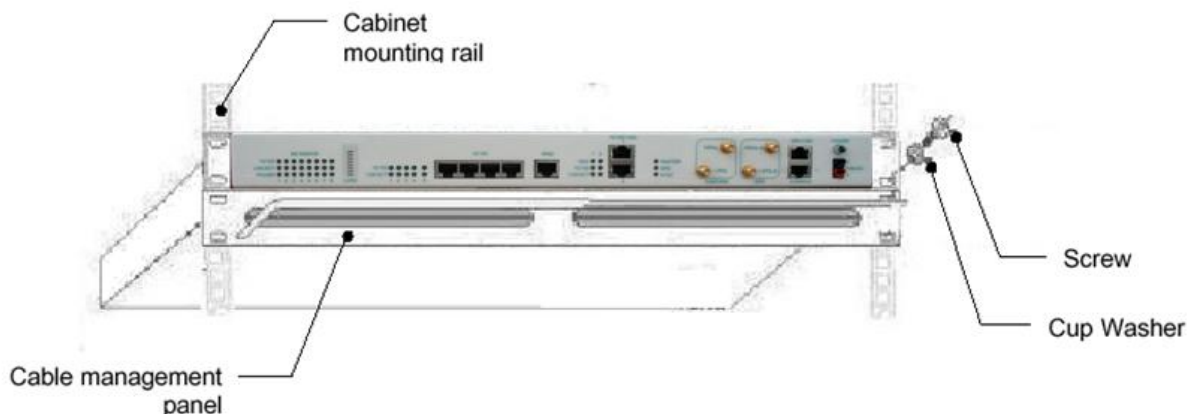

Figure 39 - Rack mounted



Note: When mounting multiple BSDUs in a cabinet, vertical spacing (above and below) is required for feeding cables to the rear.

11 Mounting the GPS

Depending on individual customer requirements and environmental influences, there are several available options for mounting the GPS:

- Pole Mounting: Using the 1" – 14 threads, the GPS can be mounted onto a standard antenna mast or mounting adapter. (not supplied)
- Mounting Plate: Using three 10-32 UNF screws, the GPS can be mounted on a flat surface with three holes on a 1.75-inch diameter circle. (not supplied)
- Direct Mounting: The unit may be mounted directly to a suitable structure that has been provided with holes suited to the GPS mounting details.

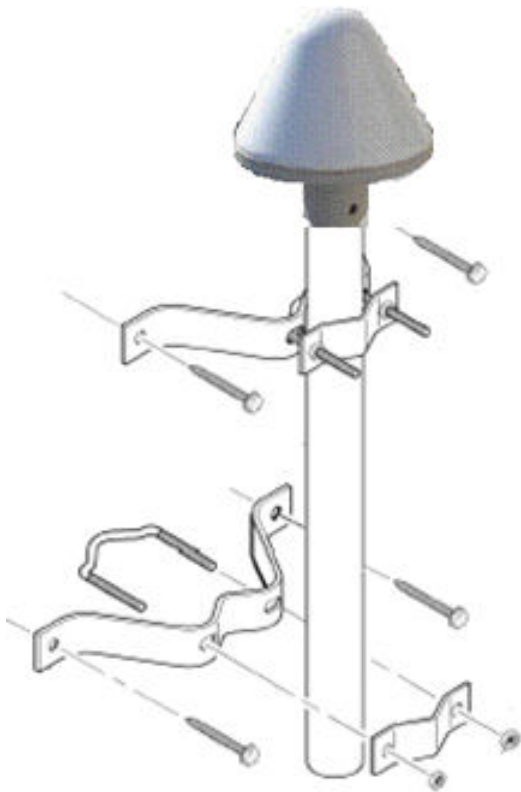

Figure 40 - GPS pole mounting



Note: When mounting the GPS on a metal pole that is in physical contact with the ground, the GPS will not synchronize. To enable synchronization, you need to isolate the GPS from the pole using isolation material.



Note: The GPS should not be mounted near to FM transmitters, whether broadcast radio, or 2-way radio, as this can cause a loss of sync. Mount the GPS away from the transmitting antenna, or physically shield from the transmitting antenna, this will assist with proper GPS operation.



12 Mounting the AC/DC Power Converter

The AC/DC Power Converter is to be mounted horizontally in a rack (ETSI or 19“)

12.1 Rack Mounting

The AC/DC Power Converter is designed for mounting in a standard 19-inch (48.3 cm) ETSI equipment rack or telco rack with 1-rack unit (1-U) of vertical rack space. Mounting bracket flanges are provided for mounting the AC/DC Power Converter into the cabinet, in its kit. Therefore, all that is required for mounting the AC/DC Power Converter is to attach the AC/DC Power Converter front-rail mounting brackets to the rack's mounting rails using the four M5-mounting screws and plastic cup washers.

To rack-mount the AC/DC Power Converter:

1. Determine the rack rail holes (left and right side) that will be used for attaching the chassis.
2. Insert four nuts into the rack's rail holes you designated in Step 1. These nuts are housed in Tinnerman clips, which allow you to fasten them into the rail holes. To insert the Tinnerman clips, hold the clips, squeeze them, and then insert them into the rail hole.
3. Carefully insert the AC/DC Power Converter into the rack, aligning the AC/DC Power Converter's mounting bracket holes with the rack rail holes.
4. Insert the M5-mounting screws, with plastic washers, into the AC/DC Power Converter mounting bracket holes, on each side, as shown in figure below. In this way, the chassis is supported until you tighten the chassis screws.
5. Tighten the M5-mounting screws to fasten the chassis to the cabinet.

12.2 Connecting Redundant PS Unit

When required an additional PS unit is available (optional) for redundancy. This hot-swappable unit is designed for ease of installation.

To install an additional PS unit

1. Check that the recessed on/off switch is in the **off** position
2. Determine the location to mount the redundant PS unit in the AC/DC Power Converter's chassis housing (usually to the left on the presently installed unit).
3. Carefully slide the unit on the rail tray until flush with front of AC/DC Power Converter's chassis housing.
4. Secure the unit by turning the Latch Lock screw, using a flat screw driver
5. Set the DIP switches (located on the back of the PS unit) to the on position for all 5 switches.

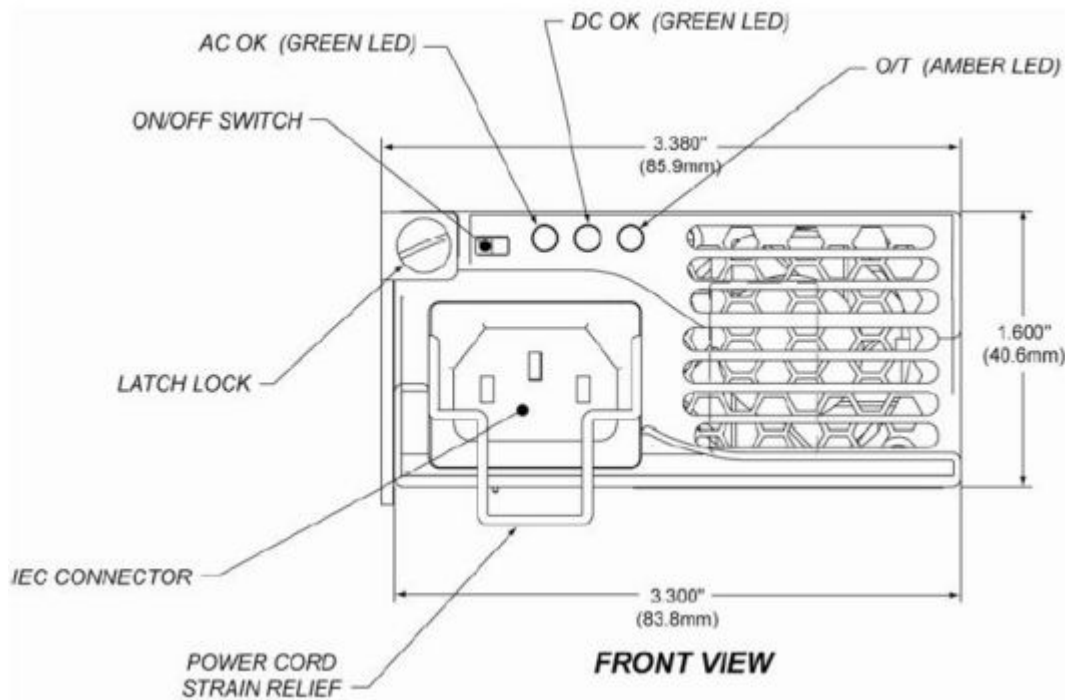

Figure 41 - PSU front

13 Cabling the BSR

Network cabling at the Base Station depends on the devices implemented to provide the BSR with connectivity to the provider's backhaul and power source. These devices can be one of the following:

- SDA: AC/DC powered and consisting of a single BSR
- BSDU: AC/DC powered and consisting of multiple BSRs



Note: SFTP (Shielded Foiled Twisted Pair) CAT-5e outdoor cable is recommended.



Note: If FM interference is discovered during installation, install a Ferrite suppressor on the CAT-5e cable, near BSR. See Lightning and Surge Protection. Refer to Commissioning Guide (Troubleshooting section) for further instructions.

13.1 Connecting the BSR to the SDA-4S

The SDA-4S provides -48 VDC power to the BSR as well as the Fast Ethernet interface between the BSR and the provider's backhaul network. The outdoor Base Station Radio and modem are powered over a CAT-5e cable by the SDA-4S Type II IDU (or the SDA-4SDC) in the minimum configuration. For larger configurations N* SDA-4Ss and N* BSRs are required or connection to BSDU(s).

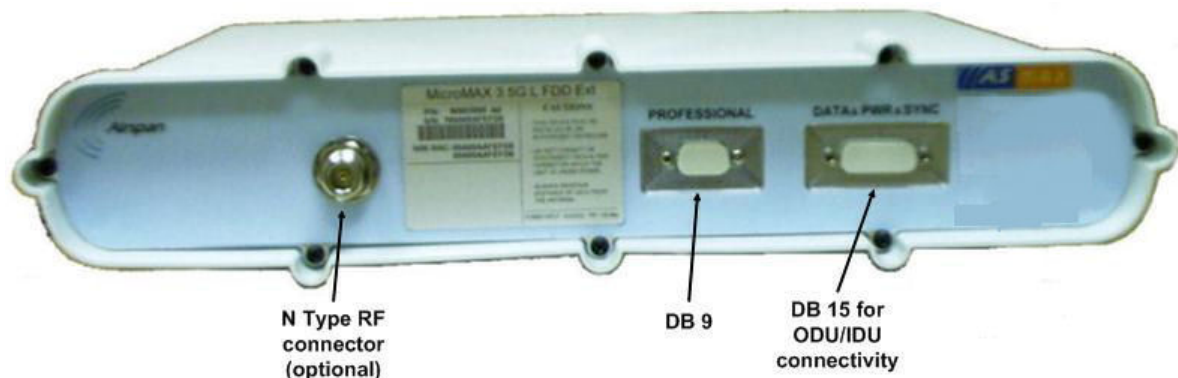

Figure 42 - BSR front panel

The BSR interfaces with the subscriber's Ethernet network through the SDA-4S. To connect the BSR to the SDA-4S, you need to connect the BSR's 15-pin D-type port to the SDA-4S's 15-pin D-type port using CAT-5e cable.

The cable setup for MicroMAX-to-SDA-4S connectivity is as follows:

- **Cable:** Straight-through CAT-5e Ethernet cable
- **Connectors:**
 - MicroMAX: DB15-to-RJ45 outdoor adapter (black color)
 - SDA-4S: DB15-to-RJ45 indoor adapter (for connecting to DATA&PWR&SYNC D-type connector)
 - CAT-5e cable with 8-pin RJ-45 male connectors on either end
- **Connector pinouts:**

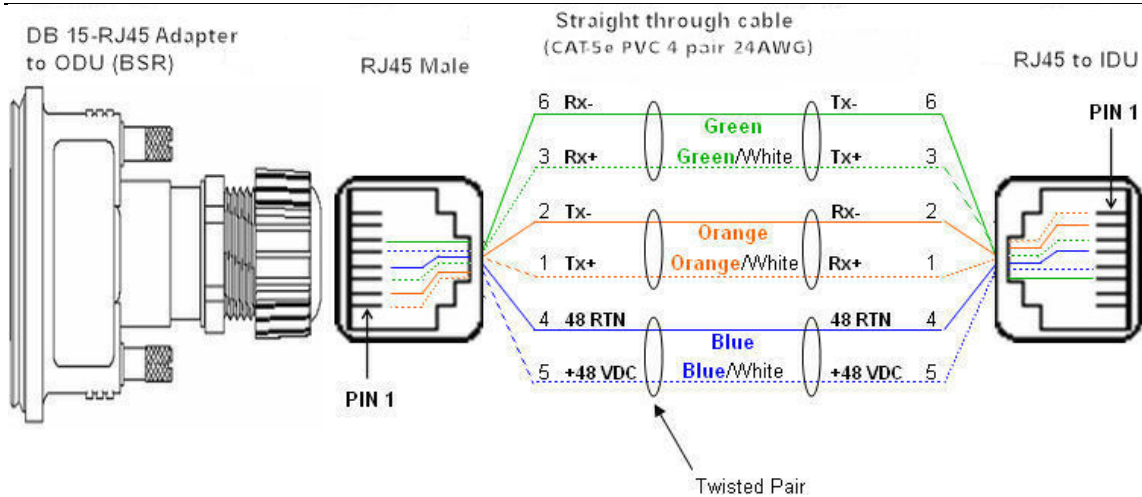

Figure 43 - Pinouts



Note: The wire color-coding described in the table is Airspan's standard for wire color-coding. However, if you implement your company's wire color-coding scheme, ensure that the wires are paired and twisted according to pin functions listed in the table above (e.g. Rx+ with Rx-).



Note: The maximum CAT-5e cable length for ODU/IDU connectivity is 100 meters.

To connect the BSR to the SDA-4S:

1. Connect the 15-pin D-type male connector, at one end of the CAT-5e cable, to the BSR's 15-pin D-type port labeled DATA&PWR&SYNC.
2. Connect the 15-pin D-type male connector, at the other end of the CAT-5e cable, to the SDA-4S's 15-pin D-type port.

13.2 SDA-4S Type II

The SDA-4S Type II (or the SDA-4SDC) provides one to four RJ-45 (100BaseT) ports for interfacing with the subscriber's LAN network.

The ports of the SDA-4S model support Auto Negotiation, allowing automatic configuration for the highest possible speed link (10BaseT or 100BaseT), and Full Duplex or Half Duplex mode. In other words, the speed of the connected device (e.g. PC) determines the speed at which packets are transmitted through the specific port. For example, if the device to which the port is connected is running at 100 Mbps, the port connection will transmit packets at 100 Mbps. Conversely, if the device to which the port is connected is running at 10 Mbps, the port connection will transmit packets at 10 Mbps

In addition, the SDA-4S ports support MDI/MDI-X automatic crossover, allowing connection to straight-through or crossover CAT-5e cables. Therefore, these ports can be connected to either a hub (i.e. using crossover cables) or a PC (i.e. using straight-through cables).

The cable setup for SDA-4S LAN connectivity is as follows:

- **Cable:** Straight-through (e.g. when connecting to PC) or crossover (i.e. when connecting to a hub) CAT-5e Ethernet cable
- **Connectors:** 8-pin RJ-45 at both ends
- Connector pinouts:
 - Straight-through cable (e.g. connecting to a PC)

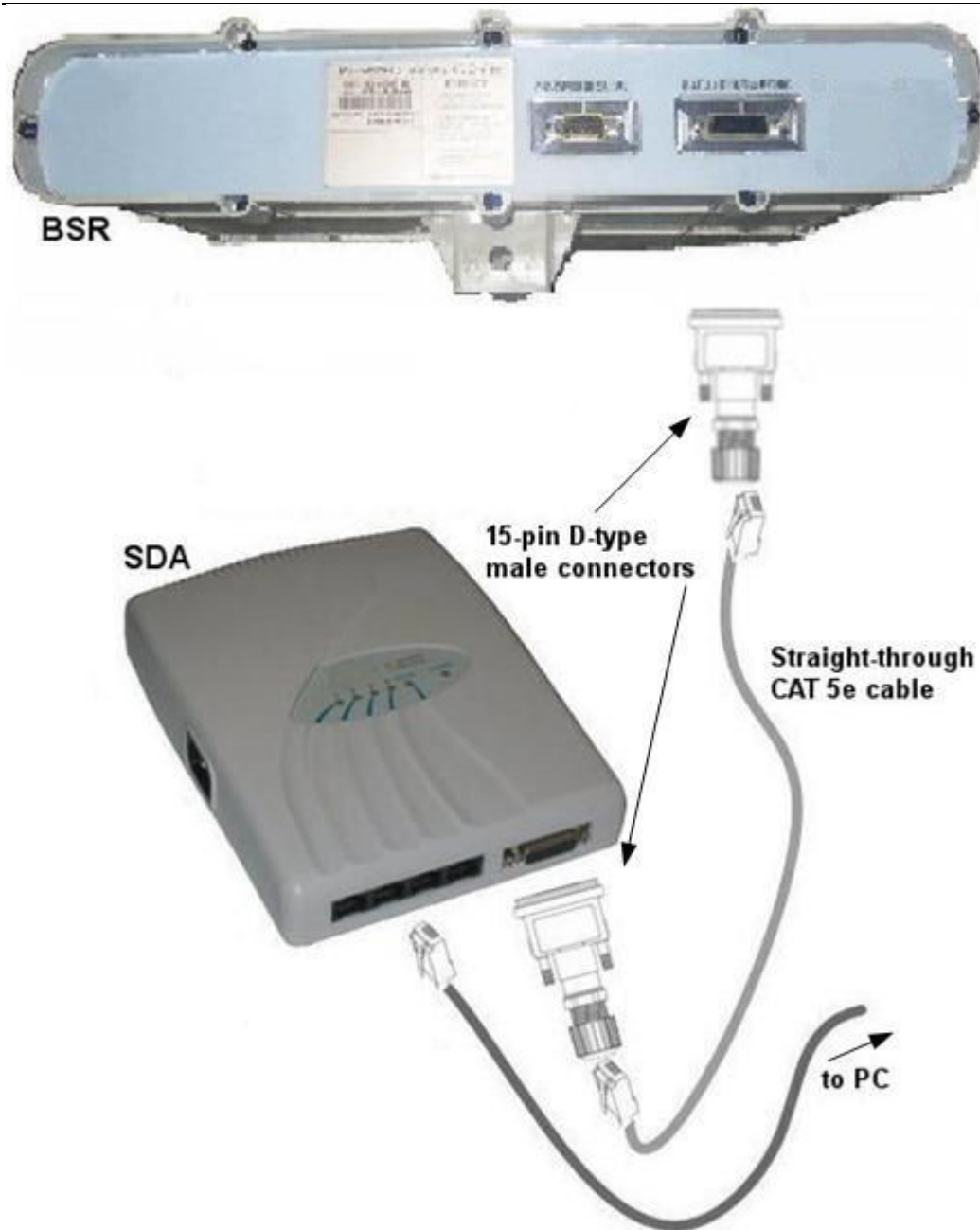

Figure 44 - BSR – SDA

13.3 Connecting the BSR to BSDU

The BSR's 15-pin D-type port is connected to one of the eight BSDU's rear panel 15-pin D-type ports (labeled Radio 8-1).

The BSR-to-BSDU cable setup is as follows:

- Cable: straight-through 10/100 Base-T Ethernet 4 Pair CAT-5e outdoor type – 22 AWG (100 meters)
- Connectors:
 - BSR side: 15-pin D-type male (only 8 pins are used)
 - BSDU side: 15-pin D-type male (only 8 pins are used)

➤ Connector pinouts:

Table 24 - BSR- BSDU connections

Straight-through CAT-5 PVC 4 Pair 24 AWG cables							
15-pin D-type male	BSR		Wire color	Wire pair	BSDU		15-pin D-type male
	Pin	Function			Pin	Function	
	1	+48 VDC	Blue / White	1	1	+48 VDC	
	2	48 RTN	Blue		2	48 RTN	
	3	Tx+	Orange / White	2	3	Rx+	
	4	Tx-	Orange		4	Rx-	
	5	Rx+	Green / White	3	5	Tx+	
	6	Rx-	Green		6	Tx-	
	7	Sync.+	Brown / White	4	7	Sync.+	
	8	Sync.-	Brown		8	Sync.-	



Note: A CAT-5e cable connects to the 15-pin D-type port; therefore, only eight pins are used (i.e. pins 9 through 15 are not used).

The wire color-coding described in the table (and shown in the figure below) is AIRSPAN WIMAX's standard for wire color-coding. However, if you implement your company's wire color-coding scheme, ensure wires are paired and twisted according to pin functions (e.g. Rx+ with Rx-).

When the BSR is connected to an SDA, pins 7 and 8 are not used (i.e. no synchronization).

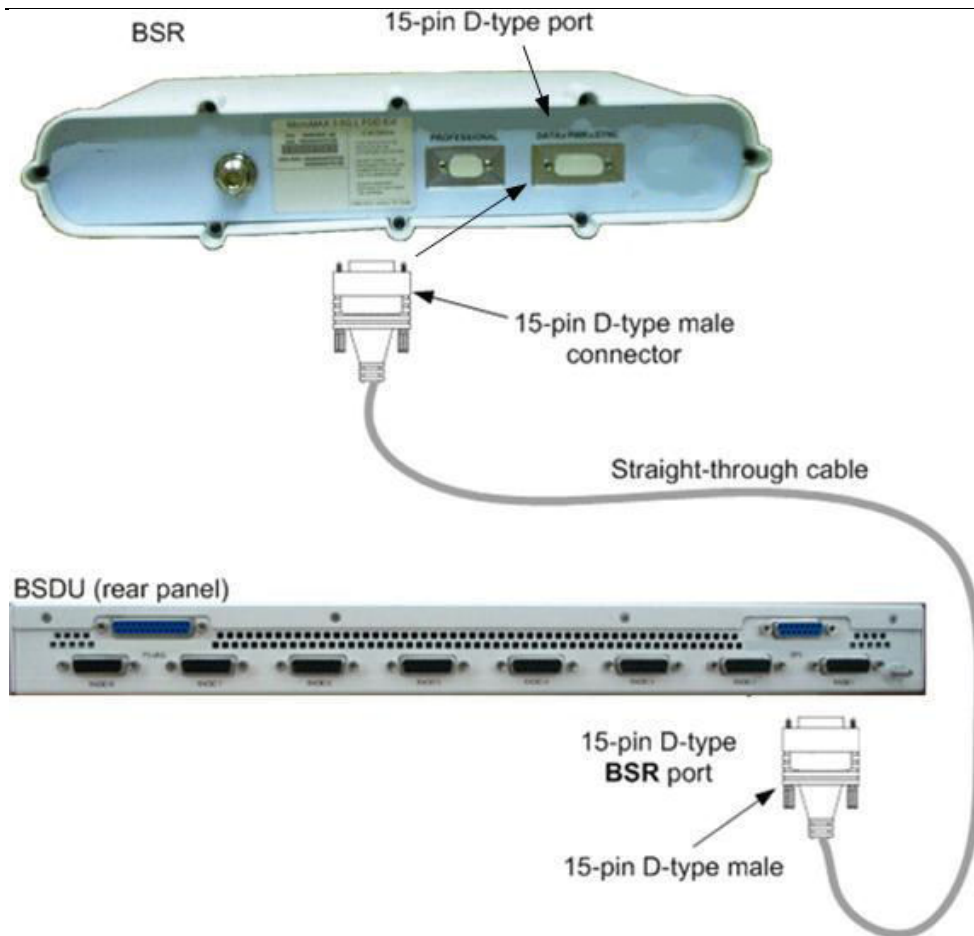

Figure 45 - BSR-to-BSDU cable connection

13.4 Connecting BSU to Network

The BSU's front panel provides two 10/100/1000 Base-T RJ-45 ports (labeled 1 & 2). These ports are used for connecting to the service provider's backbone (WAN).

- Cable: straight through
- Connector: 8-pin RJ-45
- Connector pinouts:

Table 25 - BSU-to-WAN cable connector pinouts

Straight-through cable			
BSU		WAN	
8-pin RJ 45		8-pin RJ 45	
Pin	Signal	Pin	Signal
1	Tx+	1	Rx+
2	Tx-	2	Rx-
3	Rx+	3	Tx+
6	Rx-	6	Tx-



Note: Pins not defined are not used.

To connect the BSDU's 10/100/1000 Base-T ports to the provider's backbone:

1. Connect the 8-pin RJ-45 connector, at one end of the cable, to no. 1 of the BSDU's 10/100/1000 Base-T ports, (labeled 1).
2. Connect the other end of the cable to the backbone network.

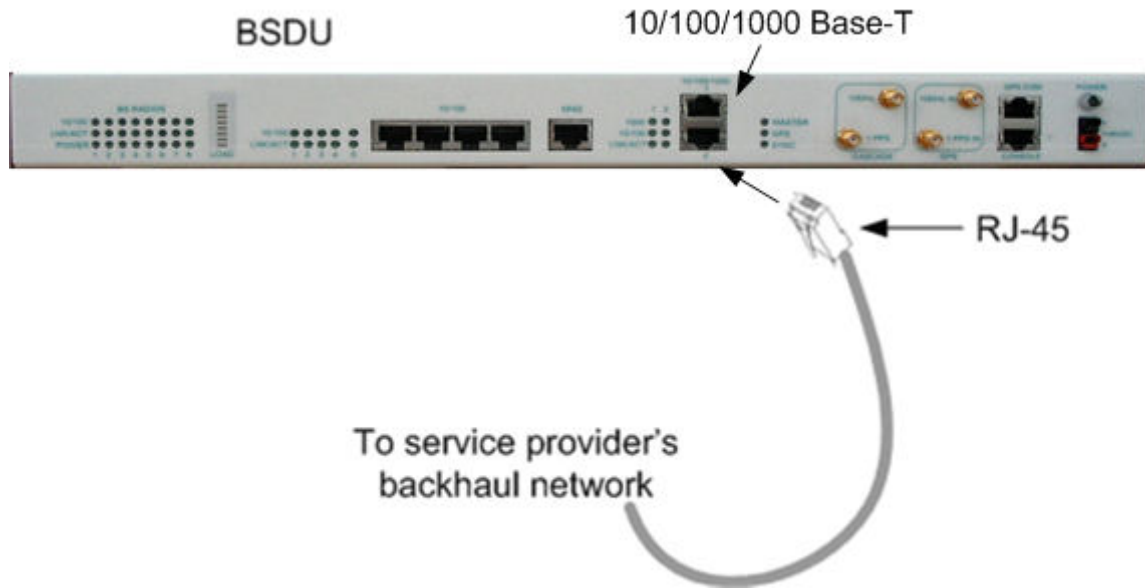

Figure 46 - BSDU-to-backhaul network

13.5 Connecting BSDUs

You can connect two (2) BSDUs at a Base Station. You can connect BSDUs by connecting the 10/100/1000 Base-T ports between BSDUs using a crossover cable.

The following lists the cable setup for BSD chaining:

- Cable: RJ-45-to-RJ-45 crossover
- Connector: 8-pin RJ-45
- Connector pinouts:

Table 26 - BSDU connecting cable connector pinouts

Crossover cable			
8-PIN RJ 45 (BSDU's 10/100/1000 BASE-T PORT)		8-PIN RJ 45 (BSDU's 10/100/1000 BASE-T PORT)	
Pin	SIGNAL	Pin	SIGNAL
1	Tx+	1	Rx+
2	Tx-	2	Rx-
3	Rx+	3	Tx+
6	Rx-	6	Tx-



Note: Pins not defined are not used.

To chain BSDUs:

1. On the first BSDU, connect the RJ-45 connector, at one end of the crossover cable, to one of the two 10/100/1000 Base-T ports (labeled 1 or 2) located on the BSDU's front panel.
2. On the second BSDU, connect the RJ-45 connector, at the other end of the crossover cable, to one of the two BSDU's 10/100/1000 Base-T ports (labeled 1 or 2) located on the BSDU's front panel.

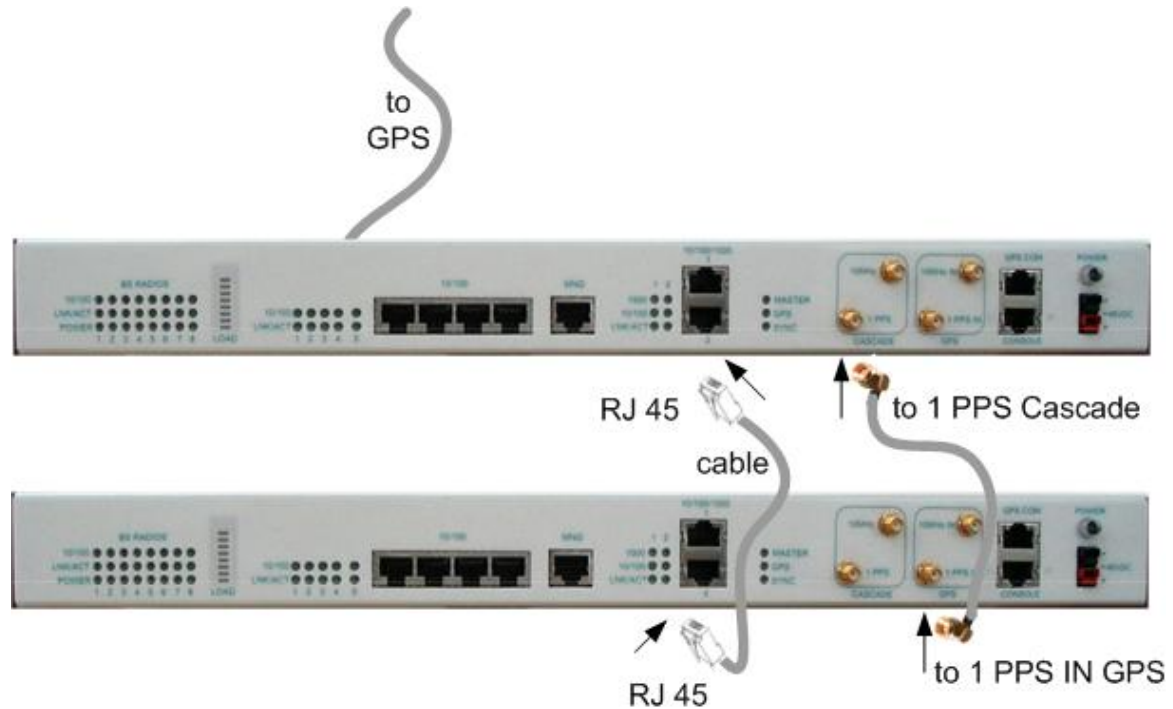

Figure 47 - Cable connections for BSDU chaining with GPS



Note: When connecting BSDU's it does not matter which one of the two 10/100/1000 Base-T ports you use two connect two BSDUs.

13.6 Connecting BSDU for SNMP Management

To configure the BSDU, or BSRs connected to the BSDU, through an IP network communication mode, you can connect the BSDU directly to the PC, or remotely (from anywhere) if you have IP connectivity to the PC.

For PC-to-BSDU local network connections you need to connect the PC to the BSDU's management port.

The following lists the cable setup for BSDU local network management:

- Cables:
 - Straight-through for connecting the PC to the BSDU management port
- Connector: 8-pin RJ-45
- Connector pinouts:

Table 27 - BSDU to PC for IP network management

Straight-through cable			
PC LAN port		BSDU management port	
8-pin RJ 45		8-pin RJ 45	
Pin	Signal	Pin	Signal
1	Tx+	1	Rx+
2	Tx-	2	Rx-
3	Rx+	3	Tx+
6	Rx-	6	Tx-

To connect the BSDU to PC for IP network management

1. Connect the RJ-45 connector, at one end of the straight-through cable, to the BSDU's management port.
2. Connect the RJ-45 connector, at the other end of the straight-through cable, to the PC's LAN port.

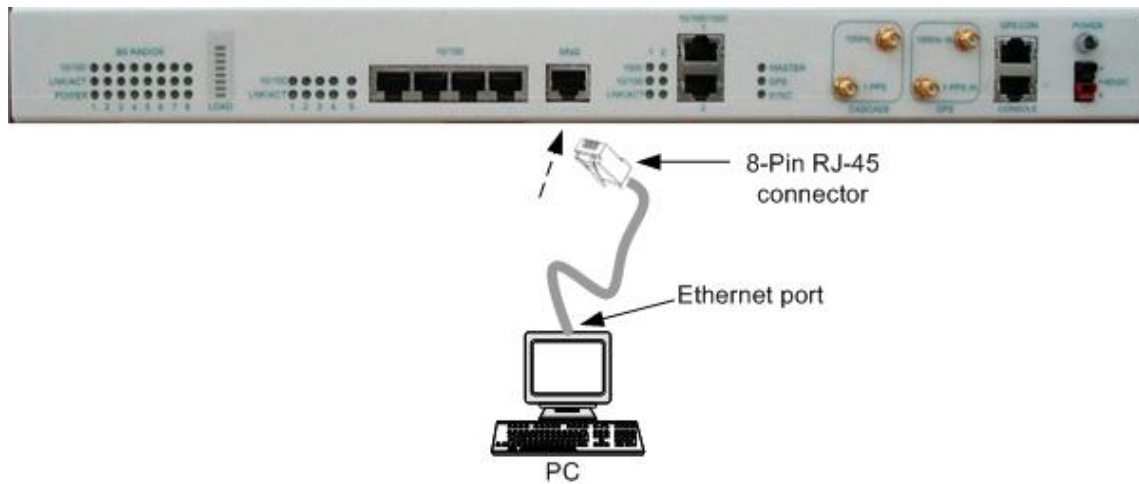

Figure 48 - BSDU-to-PC local network management cabling

14 Connecting the SDA-4S to the power supply

14.1 Connecting the SDA-4S Type II

The SDA-4S adapter is plugged into a standard electrical wall outlet (110/240 VAC) using an AC power cord. The appropriate AC power cord is supplied according to the country of use.

The cable setup between the SDA-4S and power outlet includes the following:

- **Connector:** AC IEC 60320 type (female)
- **Plug:** The appropriate plug type is supplied according to the country of use
- **Cable:** 3x1.20 mm, 10A / 250 VAC (maximum length is 180 cm)

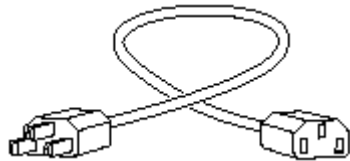

Figure 49 - Power chord

To connect the SDA-4S to the AC power supply:

1. Connect the power plug female, at the end of the AC power chord, into the AC power socket located on the left panel of the SDA-4S.
2. Plug the power plug male, at the other end of the AC power chord, into the AC power outlet (110-240 VAC).
3. Verify that the power is received by the SDA-4S by checking that the **POWER** LED light is on.

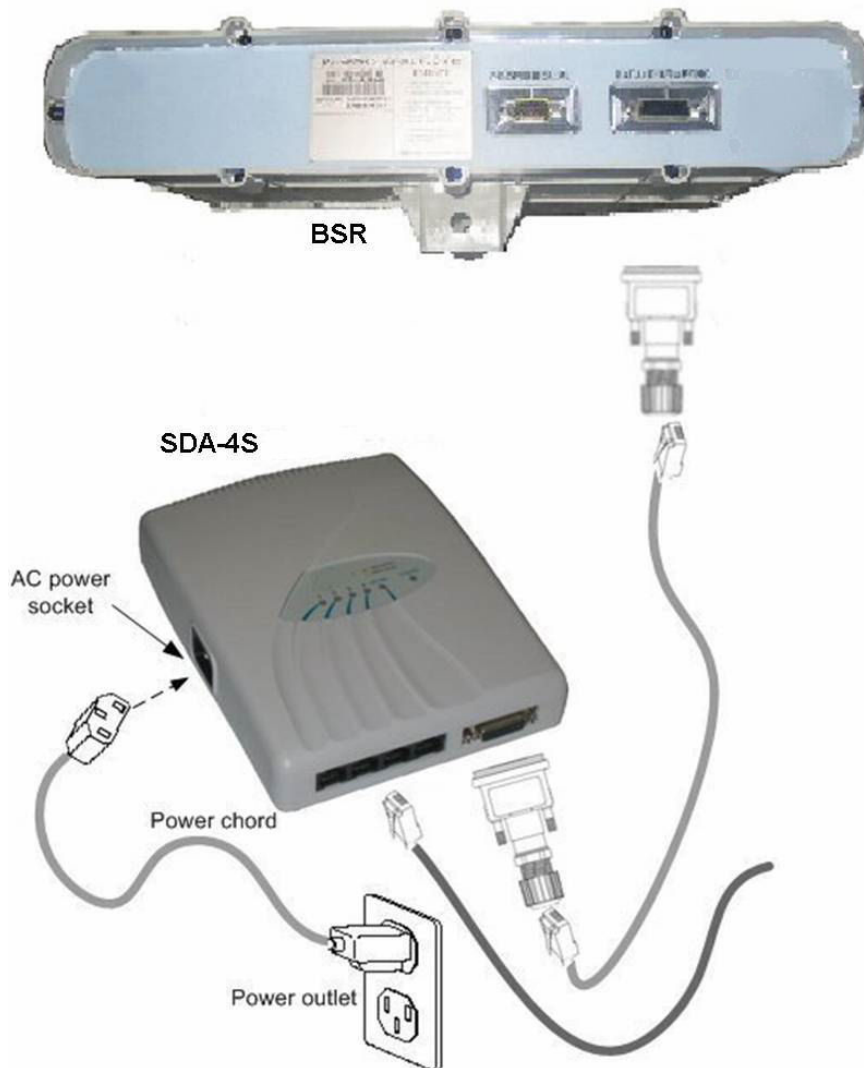

Figure 50 - Connecting to AC power

4. Verify that your SDA-4S is on and receiving power by checking that the LED labeled **POWER** is lit (see [SDA-4S LED](#) description).

14.2 Connecting the SDA-4SDC Type II

The SDA-4SDC adapter is connected to the DC power supply using a cable appropriate to the specific field conditions.

The setup between the SDA-4SDC and power connection includes the following:

- **Connector:** Anderson Connector Housings for connecting the cable to the SDA-4SDC DC power socket.
 - 1327 - Red Housing x 1
 - 1327G6 - Black Housing x 1



Note: Due to the variety of on-site conditions the cable is not supplied and should be acquired per specific connection needs.

14.3 Connecting SDA-4S to Ethernet Network

The MicroMAX typically interfaces with the subscriber's network/computer using the SDA-4S or SDA-4SDC Type II which provides four (10/100BaseT) LAN ports for interfacing with the subscriber's LAN network.

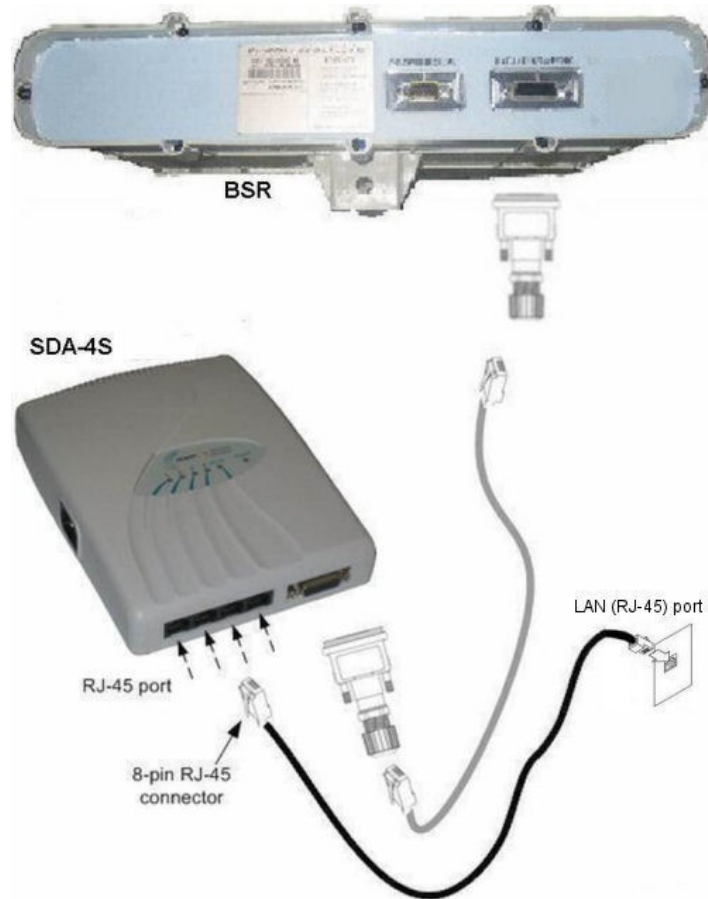

Figure 51 - Connect to Ethernet

15 Connecting Power Cable for SDA-4SDC

In the SDA-4SDC installation Kit there are two polarized and genderless unassembled Anderson Powerpole power connectors: **red** for positive connection and **black** for the negative connection.

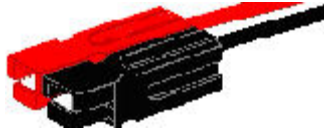

Figure 52 - Power connectors (Anderson Powerpole)

The power connectors consist of housing (hood and a contact pins). The contact pin is displayed below:



Figure 53 - Contact pin

15.1 Housing the Connectors

The power connectors are supplied unassembled. Therefore, you need to crimp the power wires to the connector's contact pins, and then house them in the Powerpole hood.

Crimping the power wires to the connectors:

1. Insert the wire into the contact pin's barrel, and then, with a standard crimping tool crimp the barrel tightly onto the wire (recommended 16 AWG cable wire).



Figure 54 – crimped

2. Insert the contact into the hood with the contact's **tongue pointing downwards** and snap into place. Ensure that the housing spring mates with the underside of the contact's tongue.



Figure 55 – Insertion

15.2 Connecting to the SDA-4SDC

Once you have crimped the power cord to the Powerpole connectors, connect the power connectors to the SDA-4SDC power receptacles.

To connect the power cord to the SDA-4SDC:



Caution: The plastic housings are held together with dovetail joints. Always slide these joints together! They will be damaged if you try to snap them together or apart. They **ONLY** slide together in one direction. This should be obvious by looking at them carefully.

1. Assemble the **red** and **black** plastic housings together. Mate both connectors, by sliding them along the dovetail joints.
When looking at the connector side (not the wire side), the **red** connector should be on the

left and the **black** on the right.
The housing dovetails should be mated fully.

2. Connect the power connectors to the SDA-4SDC power receptacles so that the connectors' color matches the receptacle's color, red to red (**positive**), and black to black (**negative**).
3. Connect the other end of the power cord to the third-party DC power source. Ensure that the positive and negative sides are correct.

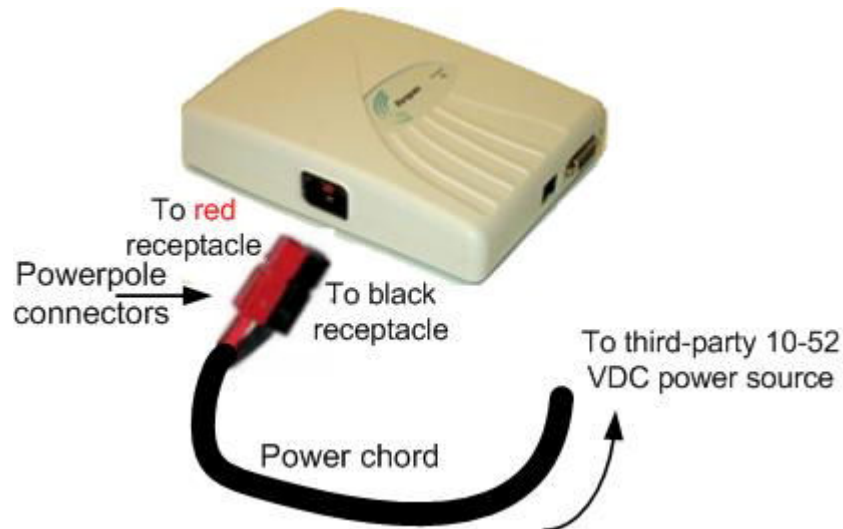

Figure 56 - Connect to power source

16 Connecting BSDU to AC/DC Power converter

This section provides a description of how to connect the **Base Station Distribution Unit (BSDU)** to the external **AC/DC Power** converter. This section explains the steps needed to connect the two units together for proper functioning.

Table 28 - Required Equipment

Equipment Description	Part number
BSDU	MMX-BSDU-1
AC/DC Converter	PC-BSDU-1
BSDU to AC/DC Converter Cable	68000110
BSDU to DC power Supply Cable	supplied with BSDU kit

16.1 Connections

There are two sets of cables required for the BSDU and AC/DC converter to work properly.

- Cable with 25-pin D-type Male to 25-pin D-Type Male (part no. 68000110) with 2 cables (UL 20AWG red color and UL 20AWG black color both with ring terminals).

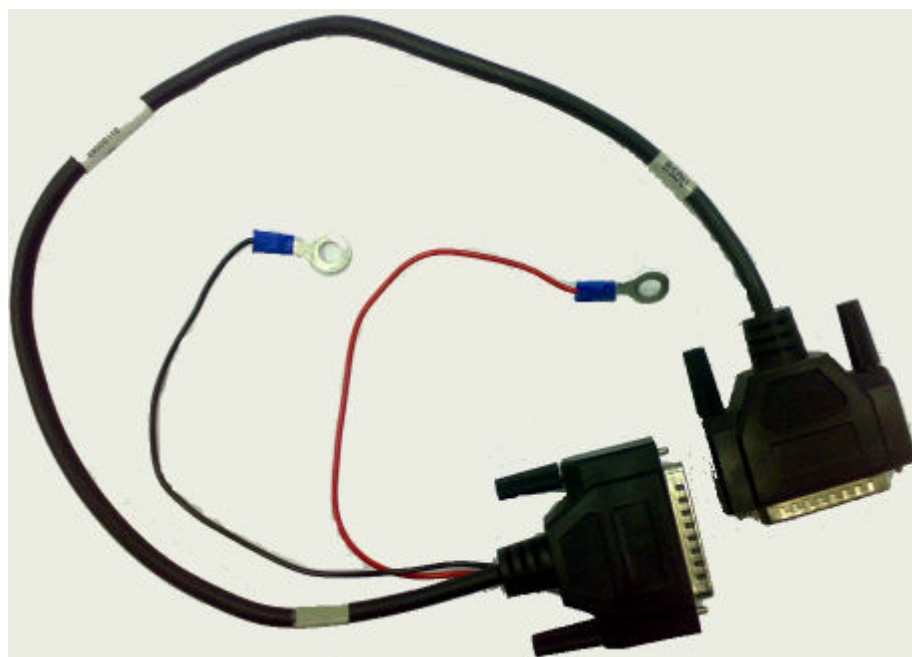

Figure 57 - BSDU - AC/DC cable



Note: This cable connects between the rear panels of the BSDU and the AC/DC converter. It also has connections to the main DC Output of the AC/DC converter, but the cable itself **DOES NOT** carry power to the BSDU. These connections are used for sensing purposes, so that the PSU can adjust the DC output according to the load drawn by the BSDU.

- BSDU to DC power supply cable (supplied with the BSDU)

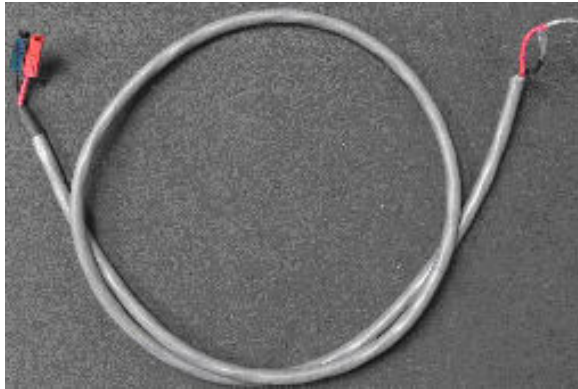

Figure 58 - BSDU to DC cable

16.2 Power Cable Assembly

In the BSDU Kit there are two polarized and genderless unassembled Anderson Powerpole power connectors: **red** for positive connection and **black** for the negative connection.

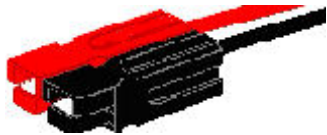

Figure 59 - Power connectors (Anderson Powerpole)

The power connectors consist of housing (hood and a contact pins). The contact pin is displayed below:



Figure 60 - Contact pin

16.3 Housing the Connectors

The power connectors are supplied unassembled. Therefore, you need to crimp the power wires to the connector's contact pins, and then house them in the Powerpole hood.

Crimping the power wires to the connectors:

1. Insert the wire into the contact pin's barrel, and then, with a standard crimping tool crimp the barrel tightly onto the wire (recommended 20AWG cable wire).



Figure 61 – Crimped

2. Insert the contact into the hood with the contact's **tongue pointing downwards** and snap into place. Ensure that the housing spring mates with the underside of the contact's tongue.



Figure 62 - Insertion

This cable connects between the rear panel of the AC/DC Converter and the -48V Power Input on the Front Panel of the BSDU.



Note: Ensure that:
 The **POSITIVE** output of the AC/DC Converter is connected to the **POSITIVE** (Red) input (lower) on the BSDU.
 The **NEGATIVE** output of the AC/DC Converter is connected to the **NEGATIVE** (Black) input (upper) on the BSDU.

16.4 Cable Connection



Caution: Confirm that all inputs to the AC/DC converter are either disconnected or powered off prior to installing the cable, otherwise damage may occur to either or both devices.

To connect the BSDU to AC/DC Converter Cable

1. Connect the end of cable 63000110 labeled **BSDU** to the **PS MNG** port on the back panel of the BSDU, as shown below.



Figure 63 - BSDU to PS MNG port

2. Connect the end of cable 63000110 marked 'PSU' to the 'J1' port on the back panel of the AC/DC Converter, as shown below.



Figure 64 - PSU to J1 port

3. Connect the Black crimped wire from the 25-pin cable connected to Port J1 on the back panel of the AC/DC Converter to the -VDC (Negative) output of the AC/DC Converter on the back panel, as shown below.

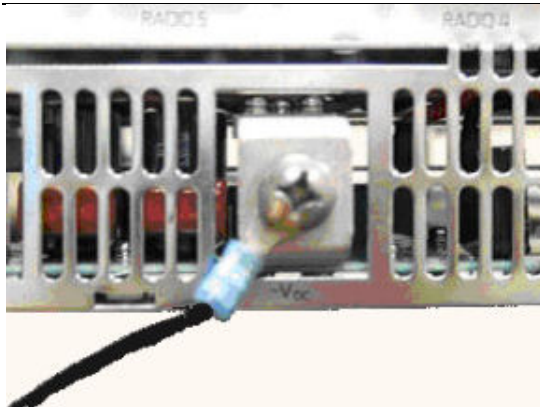

Figure 65 - Connect to Negative

4. Connect the RED crimped wire from the 25-pin cable now to Port J1 on the back panel of the AC/DC Converter to the +VDC (Positive) output of the AC/DC Converter on the back panel, as shown below.

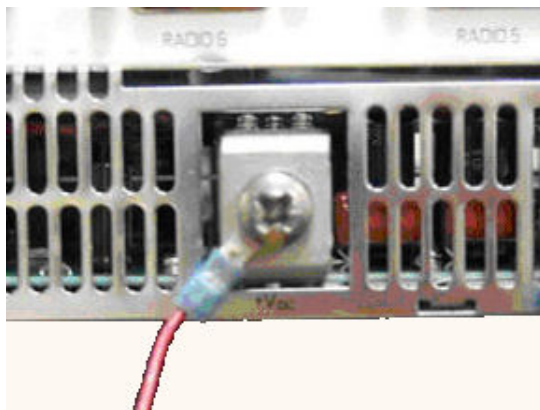

Figure 66 - Connect to Positive

5. Check the back panel of the BSDU and AC/DC Converter appears as below:

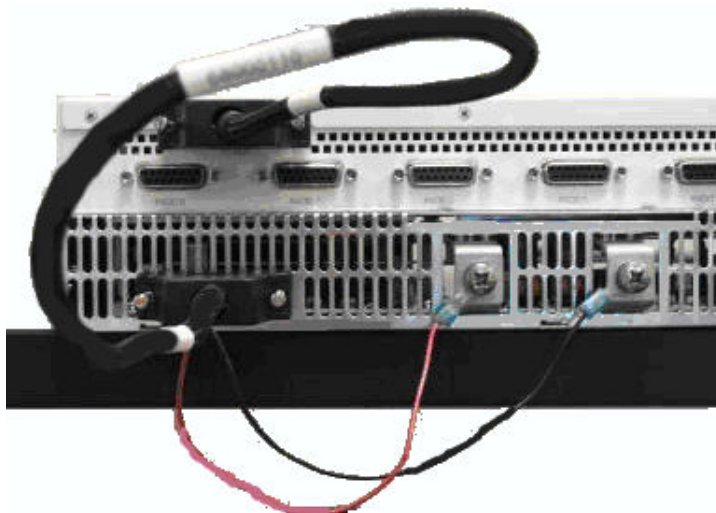

Figure 67 - Back panels

6. Connect the power cable terminated with the Anderson Powerpole connectors to the -48V input on the front panel of the BSDU, as shown below.



Figure 68 - Front power connect

7. Connect the opposite ends of the cable to the DC output on the Rear Panel of the AC/DC Converter as follows:
 - a. The +VDC (Positive) output of the AC/DC converter is connected to the + Positive (Red) input on the BSDU
 - b. The -VDC (NEGATIVE) output of the AC/DC converter is connected to the - Negative (Black) input on the BSDU

The rear panels of the BSDU and AC/DC converter, shown below:

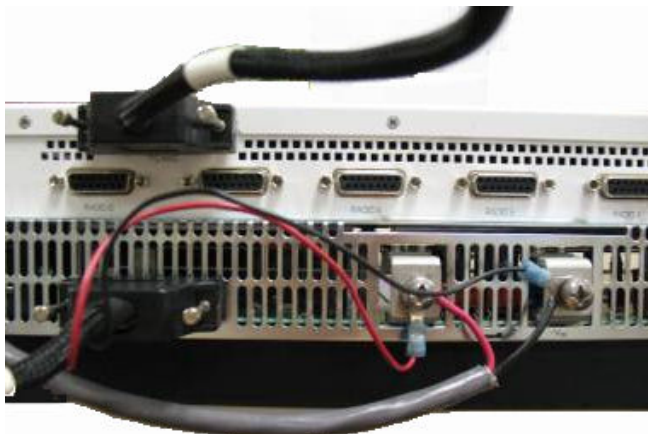

Figure 69 - Rear panels

8. Connect the AC/DC converter to AC Power and verify that:
 - a. On the AC/DC converter:
 - i. DC Supply module fans start up
 - ii. Green AC OK LED is lit
 - iii. DC OK LED is lit
 - b. On the BSDU:
 - i. All LEDs on the front panel are lit for several seconds
 - ii. The POWER LED on the front panel remains lit



Figure 70 - Front LEDs

17 Lightning and Surge Protection

This section provides information for the installation of an effective grounding and suppression system for the protection of products against lightning.

Different levels of protection should be decided jointly with customer according to:

- Geographical location / topographical conditions
- Environmental conditions
- Required level of availability
 - Emergency Services
 - Commercial – based on SLA
 - Private use – based on SLA
- Cost factors

Level 1

- SFTP CAT-5e outdoor cable with proper grounding at both ends

Level 2

- SFTP CAT-5e outdoor cable proper grounding at both ends (Level 1)
- 1 Lightning/Surge Protector on CAT-5e outdoor cable on BSDU/SDA end

Level 3

- SFTP CAT-5e outdoor cable proper grounding at both ends (Level 1)
- 1 Lightning/Surge Protector on CAT-5e outdoor cable on BSDU/SDA end (Level 2)
- Additional Lightning/Surge Protector on BSR end

Table 29 - Level of Lightning Protection

Level of Protection	Flash density *	Equipment placement **	Installation accessibility ***	Landscape
1	Low	Less than 50m	Good	Plane
2	Low	More than 50m	Good	Plane
3	Low	-	Poor	Plane
2	Medium	Less than 50m	Good	Plane
2	Medium	More than 50m	Good	Plane
3	Medium	-	Poor	Plane
3	High	-	-	Plane
1	Low	Less than 50m	Good	Hilly
2	Low	More than 50m	Good	Hilly
3	Low	-	Poor	Hilly
2	Medium	Less than 50m	Good	Hilly
2	Medium	More than 50m	Good	Hilly
3	Medium	-	Poor	Hilly



Level of Protection	Flash density *	Equipment placement **	Installation accessibility ***	Landscape
3	High	-	-	Hilly
2	Low	-	Good	Mountainous
3	Low	-	Poor	Mountainous
3	Medium	-	-	Mountainous
3	High	-	-	Mountainous

* Density (strikes per kilometer square per year)

- o Low = Less than 5
- o Medium = 5 – 14
- o High = more than 14

** Relative to ground level

*** Accessibility – cost/time affects replacement considerations

Recommended good practices:

- Air-terminal and grounded mast/tower.
- Proper Bonding
- Proper Grounding

17.1 Lightning Protection

This is to describe the known mitigation defenses in general terms for application to telecommunications facilities. A hierarchy of recognized application methods should be applied according to site realities. This matrix is depicted below:

Table 30 - Application matrix

	Exterior location	Interior Location	People Safety	Structure Safety
Air Terminals	Yes	No	No	Yes
Down Conductors	Yes	Yes	No	Yes
Bonding	Yes	Yes	Yes	Yes
Grounding	Yes	Yes	Yes	Yes
Surge Protection	Yes	Yes	Yes	Yes

17.1.1 Air Terminals

Lightning usually terminates on grounded objects sticking up in the air. This part of a lightning protection system (LPS) is based upon the principles of Path of Least Impedance. On telecom towers, ordinary sacrificial rods can protect sensitive antennae. In the main, the tower is the air terminal. the height (“H”) of the Air Terminal tip above the highest element on the tower or pole, typically the antenna, must be at least twice the distance (“2 x d”) between the outer surface of the antenna and the tower or pole. This will ensure a "protection cone" of 45° around the tower or pole. In areas of high lightning activity, the length (“H”) should be increased to up to 5 times the distance. The Down Conductor must be installed straight and vertically in order to provide the shortest and most direct path to earth. The formation of bends must be avoided.

We recommend that the Down-Conductor be at least 50 mm² or AWG 0 in all cases.

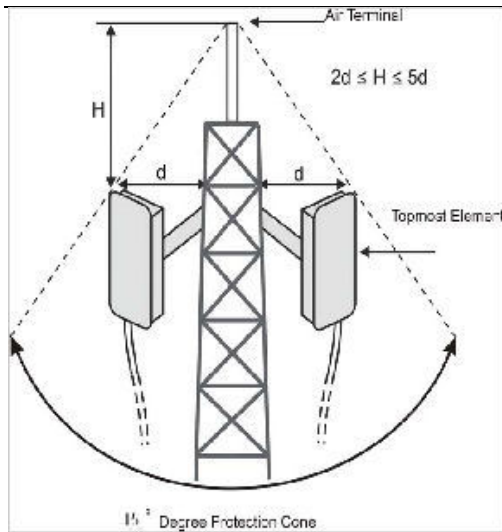

Figure 71 - Air Terminal

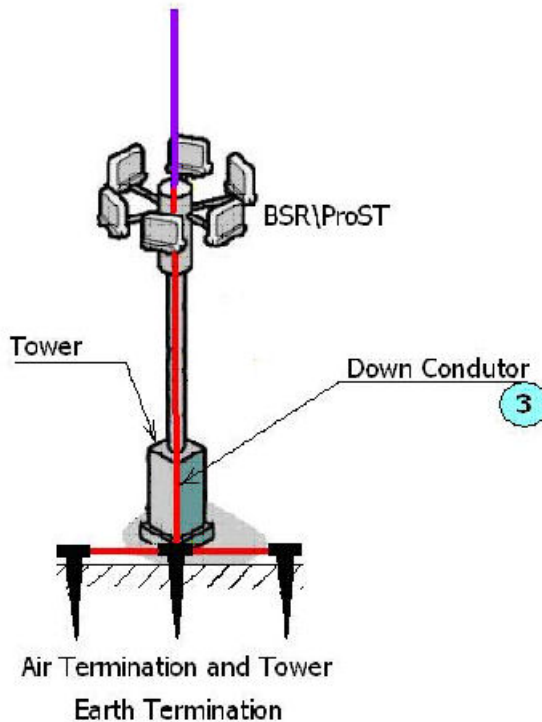

Figure 72 - Termination and Tower

17.1.2 Grounding

Low-resistance grounding provides an efficient destination for the "lightning." If the site soils are composed of sand or rock, they are resistive, not conductive. If the surrounding soils are clays or dirt with moisture present, they likely are conductive. "Good Grounds" are achieved by volumetric efficiencies. We recommend buried bare 4/0 copper wire – the so-called ring electrode or ring. The grounding of the Down Conductor to earth must be of ground resistance no higher than 5 Ω. This is achieved by using Earth Terminations and wherever possible, grounding to the steel reinforcement bars of the concrete base of the tower. This constitutes a part of the safety network adapted to the electricity laws of the country, the terrain conditions, and the accepted and relevant standards for the country.



Note: The Grounding system must be maintained and checked periodically in accordance with local regulations.

The Interconnecting cables shall be acceptable for external use and shall be rated for proper application with respect to voltage, current, anticipated temperature, flammability, and mechanical serviceability.

Hazardous network voltages are present in LAN ports regardless of whether power to the unit is ON or OFF. To avoid electric shock, use caution when near LAN ports. When detaching the cables, detach the end away from the device first.

Do not work on the system or connect or disconnect cables during period of lightning activity.

17.1.3 Surge Suppression

Surge suppression devices (LPS's aka TVSS) all function either by absorbing the transient as heat or forcing the transient to ground (or some combination thereof). Data line building entry points for critical electronic equipment. Included here is Catting 5 lines, and twin lead and other copper wire circuits.

The Lightning Protection architecture is considered, as follows:

- Subscriber Indoor Units connected to outdoor antennas. System, where Indoor/Outdoor connections are via shielded CAT-5e cables that carry the baseband signals and a DC supply voltage.
- The Lightning Protection System comprises grounding methods and Transient suppression techniques (TVS).

Airspan products contain embedded Lightning Protectors at all their input ports. If additional protection is required, for example, in high lightning activity areas, external Lightning Protectors should be installed at strategic points at the site.

The CAT-5e shielded outdoor cable consists of twisted pair wires for Ethernet data, pair of wires for the DC supply and pair of wires for sync. The Cable connects to the indoor unit via a grounded Lightning Protection Box. The Lightning Protection Box is connected to an Earth Termination via a Down-Conductor.

General Installation

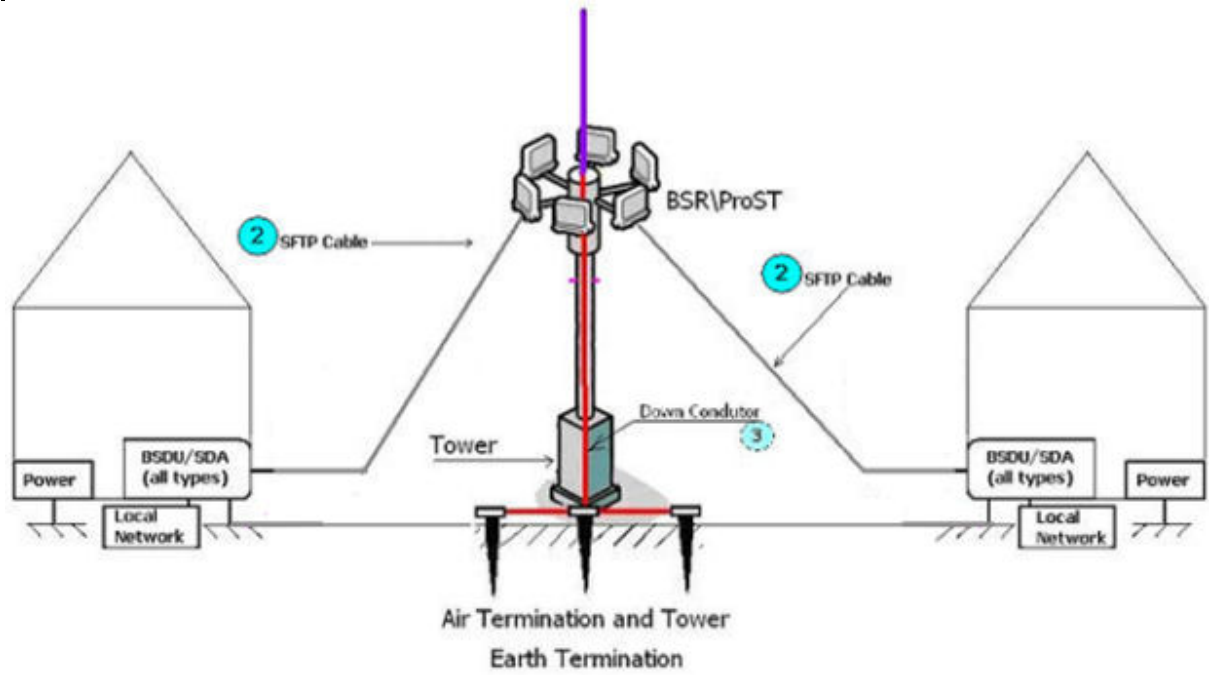

Figure 73 - Level 1

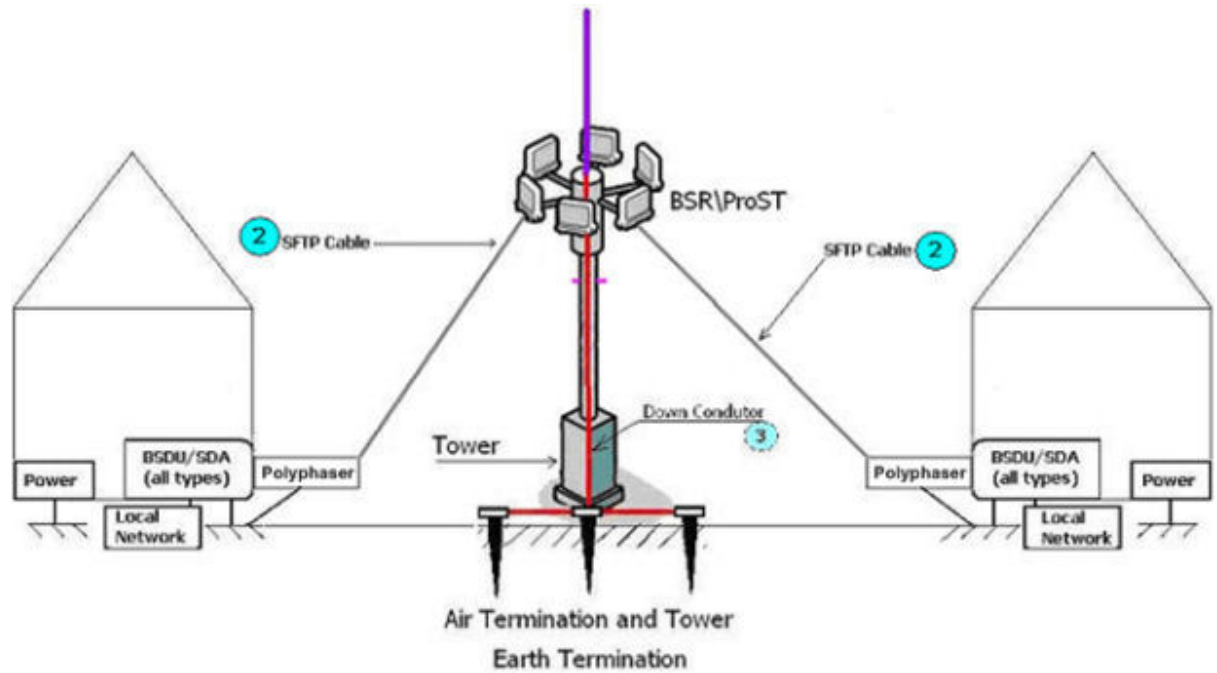

Figure 74 - Level 2

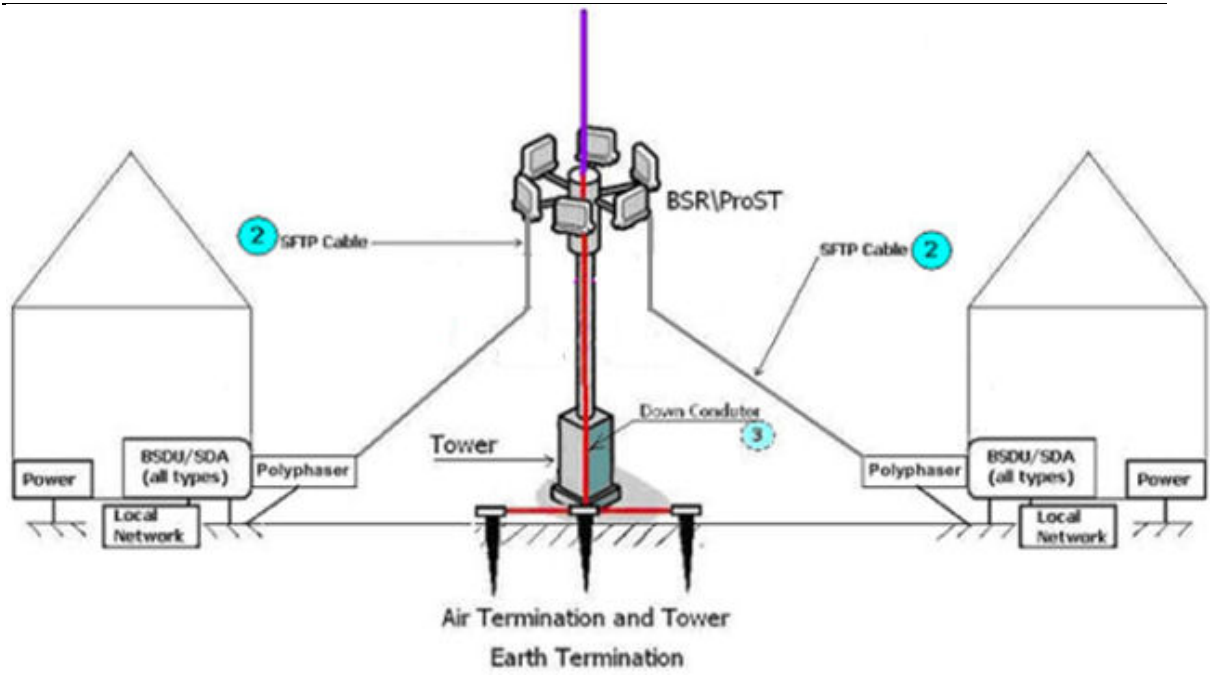

Figure 75 - Level 3

Table 31 – Accessories

Item No.	Description	Manufacturer	Manufacturer P/N	Quantity	Remark
1	Copper wire 0 AWG	N/A	N/A	N/A	Ground resistance must be less than 1 Ohm. UL approved cable
2	CAT-5e SFTP with drain and double jacket	N/A	N/A	N/A	Up to 100 meters
3	Bare Copper Wire 4/0 AWG	N/A	N/A	N/A	Ground resistance must be less than 5 Ohm. UL approved cable
	Ring terminal	N/A	N/A	N/A	Stud H (1/4), Diameter matching the used Copper Wire diameter.
	Circuit Lightning protection for BSR	Polyphaser IX series	IX-2H1L1DC48-IG	1	Installed with BSR
	Circuit Lightning protection for ProST	Polyphaser IX series	IX-2H1DC48-IG	1	Installed with ProST

17.2 Cable Preparation (for grounding)

The CAT-5e SFTP cable is supplied unassembled. Therefore, you need to crimp the drain wire to the ring terminal and paired wires to the connector's contact pins.

Required:

- CAT-5e SFTP cable
- Ring terminal and red insulation boot
- Crimping tool

To crimp the CAT-5e SFTP “drain” wire to the ring terminal:

1. Carefully strip the insulation from the SFTP cable (5 – 10cm).



Caution: Do not damage the insulation of the inner twisted pair wires.

2. Peel back the foil from around the wires.
3. Isolate the “drain” (ground) wire.
4. Crimp the ring terminal to the drain wire. Insert the wire into the ring terminal’s barrel, and then, with a standard crimping tool crimp the barrel tightly onto the wire. Fold back the drain wire with the ring terminal attached.
5. Strip the ends of the paired wires according to the connector.
6. Connect ground wire (with extension if required) to the tower.

The figures and connections are displayed below:



Figure 76 - Ring terminal

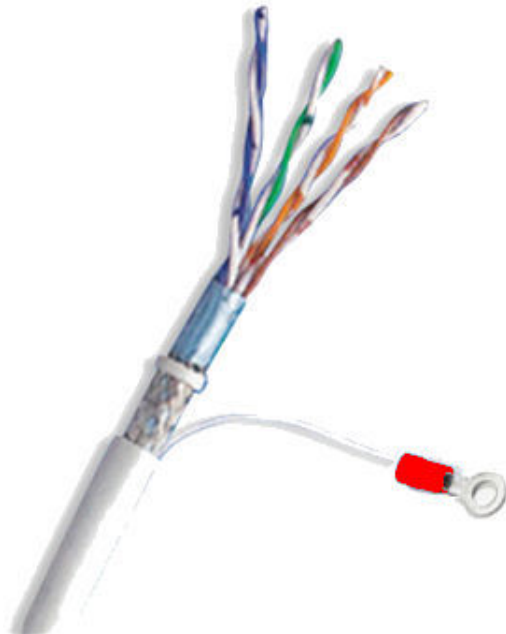

Figure 77 – CAT-5e SFTP cable with ring terminal

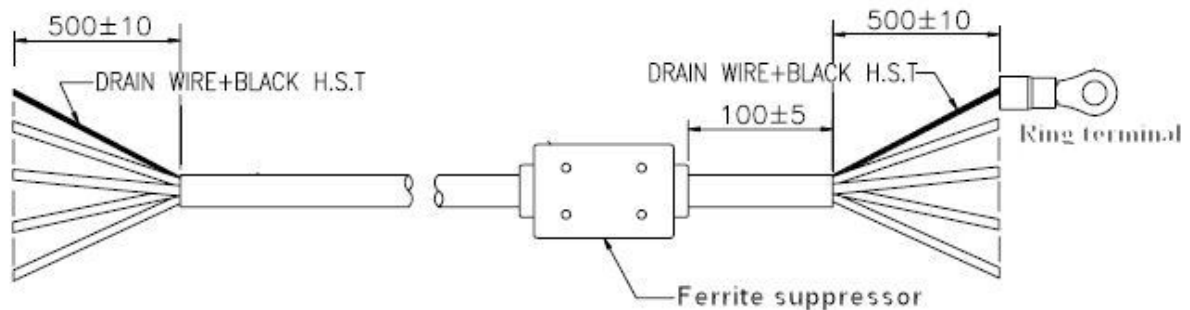

Figure 78 - Complete assembly with Ferrite (optional)

17.3 FM Interference & ESD Protection Recommendations

When FM Interference is a factor:

- Ferrite suppressor (displayed in figure above) on the CAT-5e cable, near BSR
- Loop the CAT-5e cable on the BSR end

When ESD is an issue:

- Verify that the CAT-5e SFTP cable properly grounded at both ends

17.4 Connecting Lightning and Surge Protector

The optional third-party lightning and surge protector (Polyphaser) is implemented in the following deployment scenarios:

- ODU-to-IDU cable length of 40 meters or more (**mandatory to use surge protector**)

- Deployment of MicroMAX in geographical areas that frequently experience severe lightning storms

The lightning and surge protector protects the ODU-to-IDU CAT-5e cable's six or eight (depending on configuration) (for GPS synchronization all 8 CAT-5e wires are used) used wires (two -48 VDC wires and four Ethernet Tx and Rx wires) from any electrical surges due to lightning strikes.

The protector is installed outdoors on the CA-5e cable that connects between the MicroMAX and the SDA-4S Type II (ODU). In other words, two CAT-5e cables are required for the following connections:

- MicroMAX-to-protector connection
- Protector-to-IDU connection



Caution: Do not install the lightning and surge protector during adverse weather conditions when the threat of lightning strike is possible.



Note: The protector unit must be grounded to a low-impedance (low R and low L) ground system to operate properly.



Note: For pricing and ordering of the Polyphaser lightning and surge protector, contact your Airspan representative.

To install the lightning protector:

1. Connect the protector in the direction according to the labels. The end labeled SURGE accepts the cable from the MicroMAX; the end labeled PROTECTED accepts the cable from the SDA-4S, or BSDU.
2. Feed the CAT-5e cable through the grommet (for each side). If the RJ-45 connector is already crimped to the other end, ensure that you have fed the cable through the gland nut beforehand. The gland nut secures the cable to the grommet.
3. Strip about 0.25" (6.35 mm) of the cable sheath and expose about 0.03" (0.8 mm) of the strands/wires.
4. Secure the wires to the protector's terminal block using the two spot ties. Each side of the data and DC assembly has + or – markings to ensure lines entering (surge side) match lines exiting (protected side).



Note: Polyphaser should be installed close to the units but only externally.

Polyphaser Wiring Diagrams

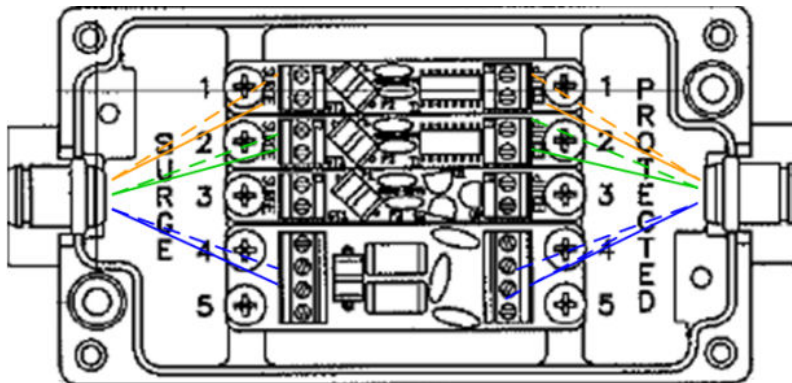

Figure 79 - Working with SDA (W/O GPS Sync)

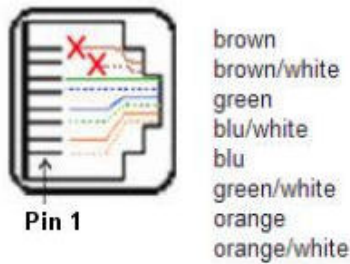

Figure 80 - RJ45 working with SDA

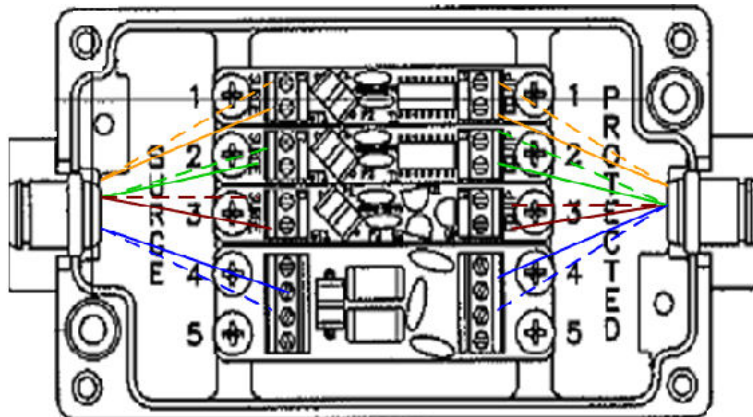

Figure 81 - Working with BSDU (GPS Sync)

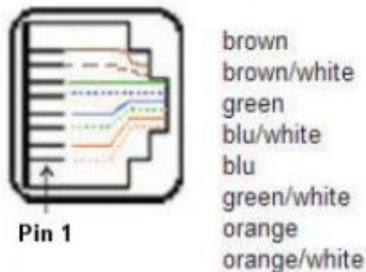

Figure 82 - RJ45 working with BSDU

5. Mount and ground the protector -s with the provided 2 x 8-32 screws according to the template illustrated below (showing distances between centers of the two mounting holes). The unit may be mounted/grounded on a nearby plate or bulkhead panel that is bonded to an earth-ground system.

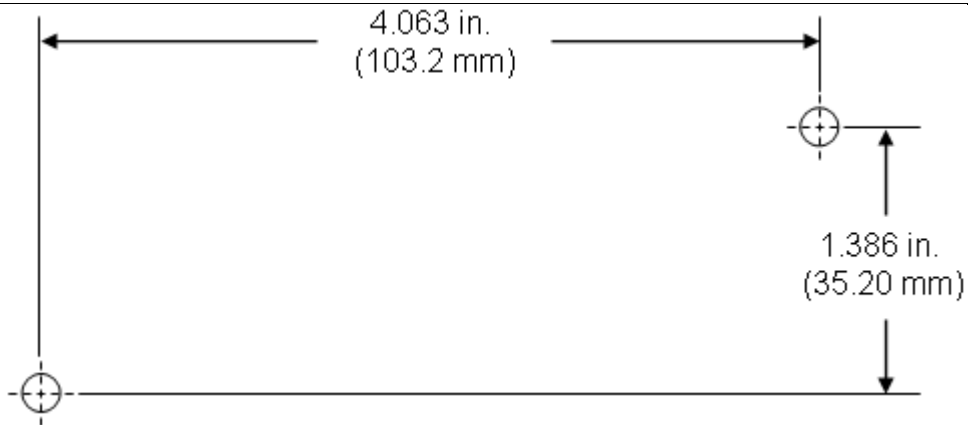

Figure 83 - Mounting template

6. Attach the protector's lid by using the four M4 x 20-mm screws. Ensure that the neoprene gasket on the lid is not loose or out of the groove.
7. Secure the CAT-5e cable to the grommet by fastening the gland nut.

17.5 Lightning and Surge Protection Connection Scenarios

The figures below illustrate various lightning and surge protector connectivity scenarios.

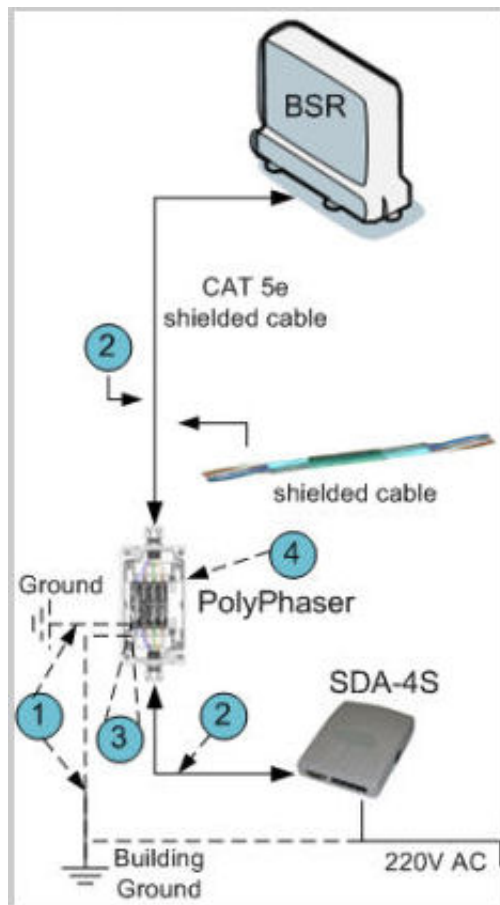

Figure 84 - SDA-4S + Polyphaser + BSR

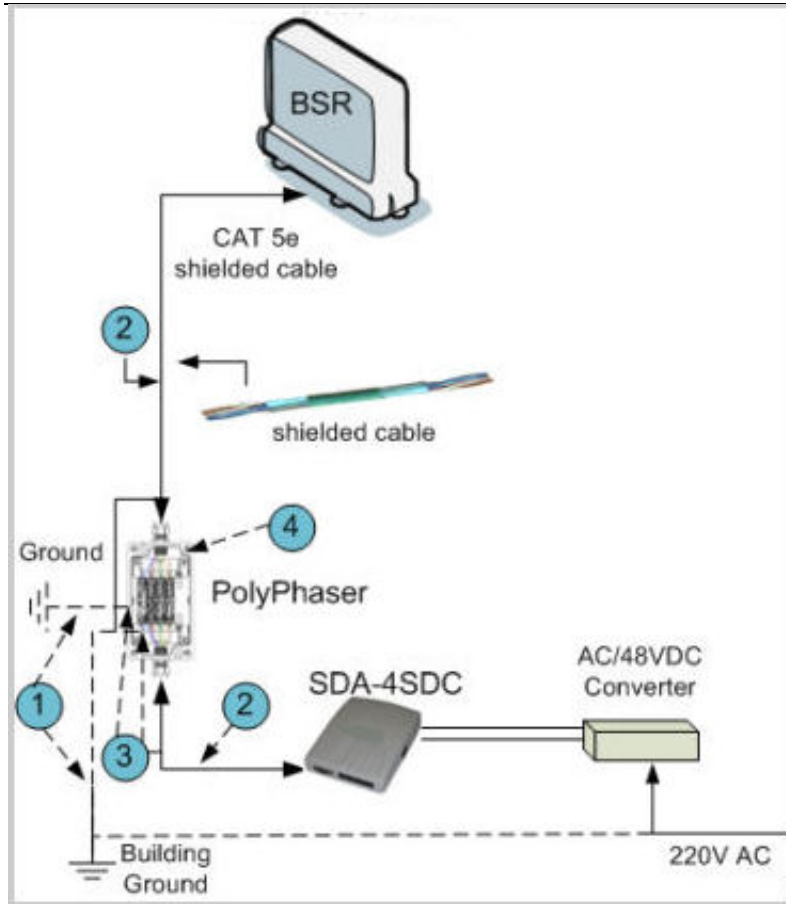

Figure 85 - SDA-4SDC + Polyphaser + BSR

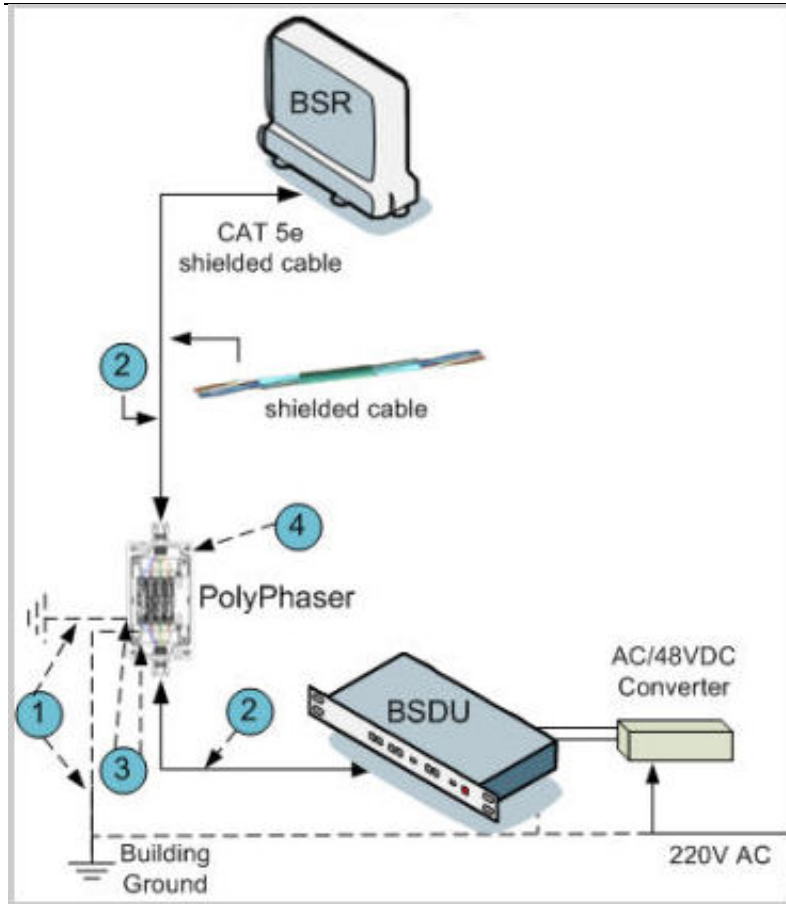

Figure 86 - BSDU + Polyphaser + BSR

The following table describes the connections:

Table 32 - Description

Item #	Description	Manufacturer	Manufacture P/N	Quantity	Comment
1	Copper wire 0 AWG	N/A	N/A	N/A	Ground resistance must be less than 5 Ohm. Cable should have UL approval.
2	SFTP Cat-5E Shielded	N/A	N/A	N/A	up to 100 meters in length
3	Ring terminal	N/A	N/A	N/A	Stud H (1/4), Diameter to match the copper wire diameter used
4	Circuit Lightning protection for BSR	Polyphaser IX series	IX-2H1L1DC48-IG	1	Installed with BSR

18 Connecting Third-Party External Antennas

This section describes the procedures for connecting third-party external radio and Global Positioning System (GPS) antennas to the BSR and BSDU, respectively. The implementation of these antennas depends on the BSR model (with respect to radio antennas) and the need for synchronization of the system (with respect to GPS antennas).

The MicroMAX BSR model without a built-in antenna provides an N-type port for connecting a third-party external antenna. The addition of an external antenna allows greater RF sector coverage than the standard MicroMAX BSR built-in antenna model.



Caution: Before connecting the external antenna, ensure that the MicroMAX is not connected to the power source.



Caution: Before powering on the MicroMAX, ensure that some type of equipment such as an antenna or an RF attenuator is connected to the N-type receptacle. This eliminates the risk of irreversibly damaging the MicroMAX device.



Caution: It is the responsibility of the person installing the MicroMAX to ensure that only those antennas certified with the product are used. The use of any antenna other than those certified with the product is expressly forbidden.



Caution: The external antenna must not be co-located or operating in conjunction with any other antenna or transmitter.



Caution: The MicroMAX and external antenna should be installed ONLY by experienced installation professionals who are familiar with the local building and safety codes and are licensed by the appropriate government authorities.



Note: The MicroMAX model that provides an N-type connector for attaching a third-party external antenna does not contain an internal, built-in antenna.

The following lists the cable setup for attaching the external antenna:

- Cable: RF coaxial
- Connector: N-type male

To connect a third-party external antenna to the MicroMAX:

- Connect the N-type male connector of the third-party antenna to the N-type receptacle located on the MicroMAX's panel (labeled ANTENNA), as displayed below.

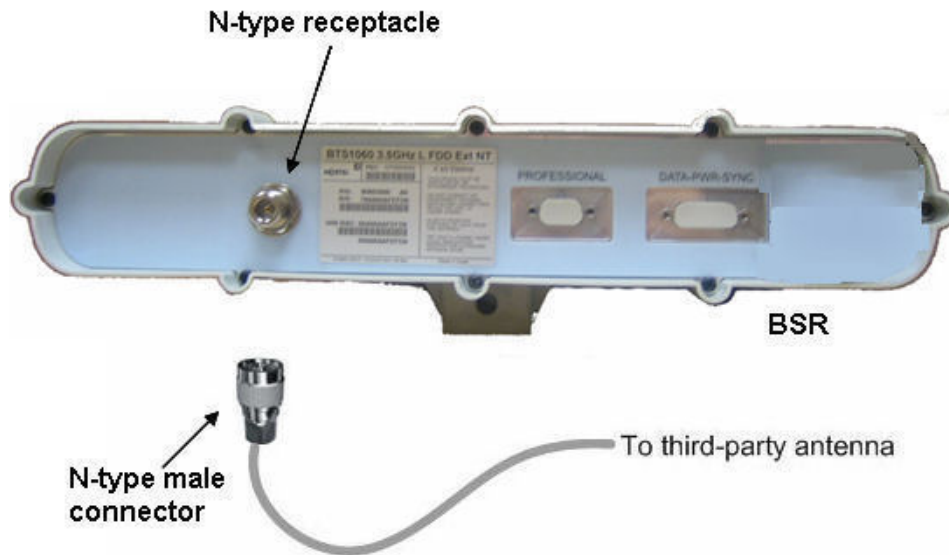

Figure 87 - Antenna connection

18.1 Connecting GPS Antenna to BSDU



Caution: To avoid electrical or fire hazard, ensure that the connection to the GPS is made prior to connecting the BSDU to the power supply.



Caution: A primary lightning protection device must be provided by the operator/customer as part of an extra-building installation to ensure transient voltage levels of less than 600 V maximum.



Caution: Changes or modifications to this equipment not expressly approved by Airspan Networks Inc. could result in violation of Part 15 of the FCC rules.



Caution: This is a Class B product. In a domestic environment this product may cause radio interference in which case the user may be required to take adequate measures to correct the interference.

18.1.1 Connecting the GPS

The GPS antenna connects to the BSDU's 15-pin D-type port, labeled GPS, located on the BSDU's rear panel, as shown below. The connection to the GPS is made through a 12-pin RS-422 serial interface port that provides both communication and power interfaces.



Figure 88 - BSDU rear panel GPS port



Caution: To avoid electrical or fire hazard, ensure that the connection to the GPS is made prior to connecting the BSDU to the power supply.

The GPS-to-BSDU cable setup is as follows:

- Cable: 12-pin conductor cable for RS-422 serial interface (multipair overall shielded -- 22 AWG) of 5, 15, or 30 meters in length depending on customer requirements (100 meter maximum length)
- Connectors:
 - GPS side: RS-422 weathertight 12-pin plug (Deutsch MMP26C-2212S1)
 - BSDU side: 15-pin D-type male
 - Connector pinouts: The GPS connector receptacle contains 12 male contacts, as displayed below:

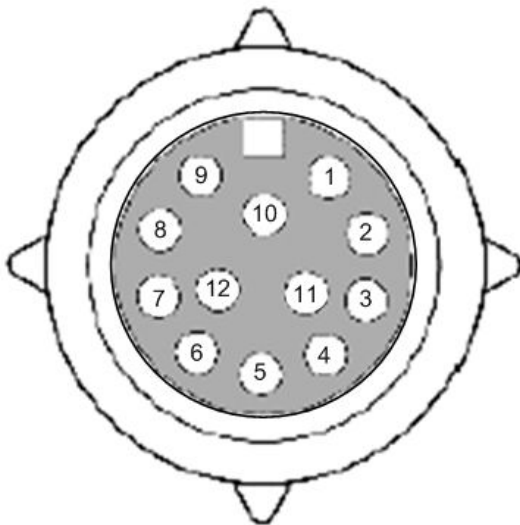

Figure 89 - GPS connector pinouts



The connector pinouts for the GPS-to-BSDU 12-pin cabling are described in the table below.

Table 33 - Connector pinouts for BSDU-to-GPS cabling

Multipair overall shielded (22 AWG) cable	
GPS	BSDU
12-pin female	15-pin D-type male
Pin	Pin
1	13
2	6
3	5
4	4
5	3
6(NC)	x
7(NC)	x
8(NC)	x
9	12
10	x
11	7
12	8

To connect the GPS antenna to the BSDU:

1. Connect the 12-pin female connector, at one end of the cable, to the 12-pin receptacle located on the underside of the GPS.
2. Connect the 15-pin D-type male connector, at the other end of the cable, to the 15-pin D-type port labeled GPS located on the rear panel of the BSDU.

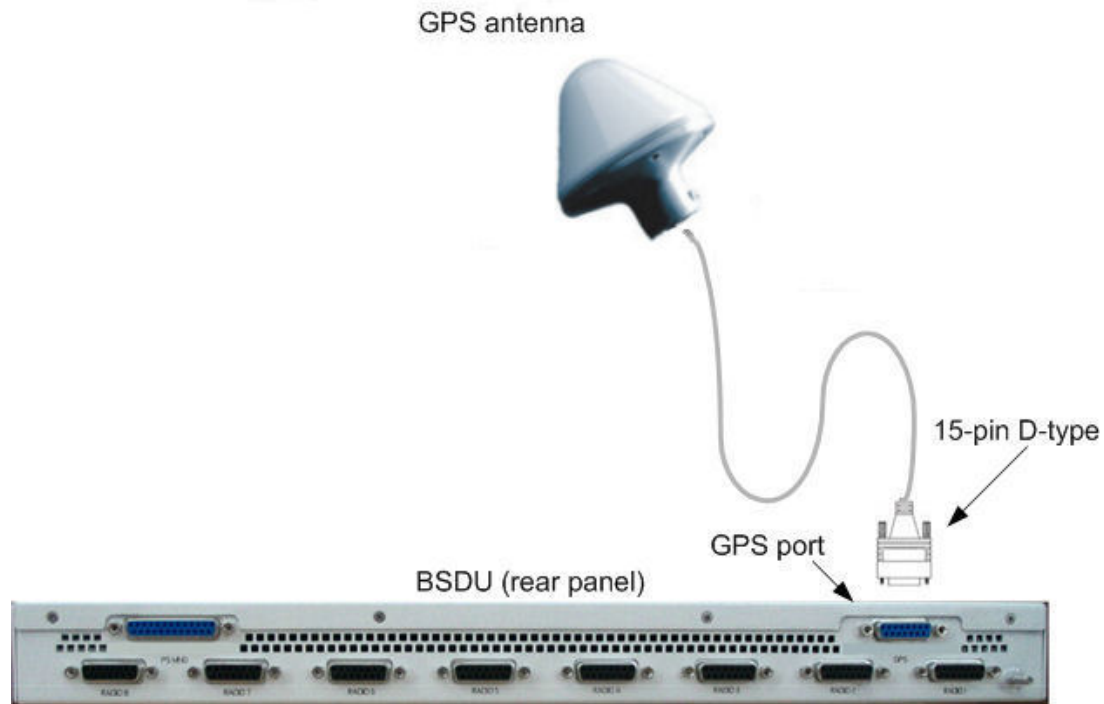

Figure 90 - GPS-to-BSDU cable connection



Note:

- When installing the cable, secure the cable to the mounting pole or bracket with a cable tie to hold the weight of the cable (i.e. cable strain relief).
- A loop should be left in the dressed cable for maintenance purposes and to prevent the cable weight being taken directly on the connector itself.
- Ensure that the connector is waterproof.

18.1.2 GPS Alignment

Many GPS reception problems can be reduced, to some degree, by careful antenna site selection.

- Place the GPS so that unobstructed line-of-sight reception is possible from horizon to horizon and at all bearings and elevation angles from the antenna. This is the ideal situation, which may not be possible under actual operating conditions.
- Try to place the GPS as far as possible from reflective objects, especially reflective objects that are above its radiation pattern horizon. Close-in reflections cause strong multipath signals.
- Care should also be taken to avoid coiling the GPS cable around the mounting base and pinching the cable in windows or doors.

19 Appendix

19.1 Environmental

Table 34 - BSR & SDA

Environmental			
ETS 300 019-1-1	19 92	Class 1.2	Environmental conditions: storage
ETS 300 019-1-2	19 92	Class 2.3	Environmental conditions: transport
ETS 019-1-3	19 92	Class 3.2	Environmental conditions: stationary weather-protected
Operating Temperature	-33° to +55° C for outdoor MicroMAX BSR 0 to +40° C for indoor SDA		
Humidity	95% @ 40° C (non condensing)		
Storage Temperatures	-40 to 70° C ambient		
EMC	ETS EN 301 489-4		
Safety	IEC60950-1, EN60950-1, UL60950-1		

Table 35 – BSDU

Environmental			
	ETS	3000 019	ETSI
EMC	EN	300 386-2	ETSI
	FCC	47CFR 15 sub B	FCC
Safety	Underwriters Laboratories (UL)	1950	USA
	IEC	60950	International
	EN	60950	ETSI
Operating temperature	0-50° C ambient		
Storage temperature	-40 to 70° C ambient		
Operating Humidity	15-90% RH		
Storage Humidity	5-95% RH		

Table 36 - GPSD

Environmental	
Operating Temperature	0 to +40° C

19.2 Glossary of Terms

AAS	Adaptive antenna system (see Introduction for further details)
AP	Access point
API	Application programmers interface
ATCA	Advanced telecommunications computing architecture
BE	Best effort scheduling service for requesting uplink bandwidth
BER	Bit error rate
BS	Base station
BSDU	Base Station Distribution Unit
BSR	Base Station Radio
BWA	Broadband wireless access
CIR	Committed information rate used to specify the guaranteed data rate to the customer.
CPE	Customer premises equipment (interchangeable with ST)
DCD	Downlink channel descriptor
DL	Downlink
DLFP	Downlink frame prefix
E1	ITU term for a 2Mb/s pulse code modulated transmission link
EIRP	Effective isotropic radiated power
FCH	Frame control header
FDD	Frequency division duplex
FEC	Forward error correction
FFT	Fast Fourier transform used to convert a signal from the time domain into the frequency domain
H-FDD	Half duplex FDD
IAD	Integrated access device
IP	Internet protocol
Kb/s	Kilobits per second
MAC	The next layer up from the PHY, known as the media access controller
Mb/s	Megabits per second
MIB	Management interface block
MIMO	Multiple-in, multiple-out
MIR	Maximum information rate used to specify the maximum data throughput to a customer.
MRC	Maximal-ratio combining
NPI	New Product Introduction
NLOS	None line of sight radio propagation path



NRTP	Non real time polling is similar to real time polling but is used to request uplink bandwidth less regularly
O&M	Operations and maintenance
ODU	Outdoor unit associated with a ST
OFDM	Orthogonal frequency division multiplexing
PHY	The physical layer associated with the WiMAX interconnection stack
PMP	Point to multipoint radio systems architecture
PoE	Point to point protocol over Ethernet
PtP	Point to point radio systems architecture
QoS	Quality of service, which is used to specify level of data throughput
REC	Radio equipment controller
RTP	Real time polling allows a service flow to request uplink bandwidth at regular intervals
Rx	Receiver
SDMA	Space division multiple access is a technique which makes it possible to increase the capacity of a cellular mobile radio system by taking advantage of spatial separation between users
SDR	Software defined radio
SF	Service flow
SFTP	Shielded Foiled Twisted Pair (cable type)
SME	Small to medium sized enterprise
SNMP	Simple network management protocol
SNR	Signal to noise
SOFDMA	Scalable orthogonal frequency division multiplexing
SoHo	Small office/home office
SS	Subscriber station (interchangeable with CPE or ST)
ST	Subscriber terminal (interchangeable with CPE or SS)
STC	Space time coding
T1	North American standard 1.56Mb/s pulse code modulated transmission link
TDD	Time division duplex
TDM	Time division multiplexing
Tx	Transmitter
UCD	Uplink channel descriptor
UGS	Unsolicited grant service used to provide fixed bandwidth slots on the uplink for an ST to transmit data at regular intervals. The bandwidth should be used by the UGS SF, however the final decision of which SF (if any) uses the bandwidth slot is made by the ST.
VoIP	Voice over Internet protocol



WiMAX

WiMAX is a wireless industry coalition whose members are organized to advance IEEE 802.16 standards for broadband wireless access (BWA) networks.



19.3 Revision History

Revision	Originator	Date	Description
Rev A	M. Falik	5-2006	Initial document
Rev B	M. Falik	6-2006	additional content
Rev C	M. Falik	6-2006	corrections
Rev D	M. Falik	9-2006	added Polyphaser
Rev E	M. Falik	10-2006	Added SDA-4SDC
Rev F	M. Falik	4-2007	Added BSDU and GPS
Rev G	M. Falik	10-2007	Added Polyphaser Info + charts
Rev H	M. Falik	2-2008	Additions
Rev I	M. Falik	7-2008	Template change + updates
Rev J	M. Falik	2-2009	Additions + corrections

19.4 Contact Information

Customer Service Help-Desk for customer service emergency

Airspan Networks have introduced the [Airspan Tracker](#) application to enable prompt and efficient Customer Support services.

If you do not have an Airspan Tracker account, please obtain login credentials by filling-in the form in the main page "[Register New Account](#)".

Worldwide Headquarters:

Airspan Networks Inc.
777, Yamato Road, Suite 105,
Boca Raton, FL 3341-4408, USA
Tel: +1 561 893 8670

www.airspan.com

Feedback:

To provide feedback on this document, please send comments to the following email address:

www.airspan.com