



UGD-D00181 Rev G

**Air4G
Installation Guide**

System Release 9.5





Copyright

© Copyright by **Airspan Networks Inc.**, 2010. All rights reserved worldwide.

The information contained within this document is proprietary and is subject to all relevant copyright, patent and other laws protecting intellectual property, as well as any specific agreements protecting Airspan Networks Inc. rights in the aforesaid information. Neither this document nor the information contained herein may be published, reproduced or disclosed to third parties, in whole or in part, without the express, prior, written permission of Airspan Networks Inc. In addition, any use of this document or the information contained herein for the purposes other than those for which it is disclosed is strictly forbidden.

Airspan Networks Inc. reserves the right, without prior notice or liability, to make changes in equipment design or specifications.

Information supplied by Airspan Networks Inc. is believed to be accurate and reliable. However, no responsibility is assumed by Airspan Networks Inc. for the use thereof nor for the rights of third parties which may be effected in any way by the use of thereof.

Any representation(s) in this document concerning performance of Airspan Networks Inc. product(s) are for informational purposes only and are not warranties of future performance, either expressed or implied. Airspan Networks Inc. standard limited warranty, stated in its sales contract or order confirmation form, is the only warranty offered by Airspan Networks Inc. in relation thereto.

This document may contain flaws, omissions or typesetting errors; no warranty is granted nor liability assumed in relation thereto unless specifically undertaken in Airspan Networks Inc. sales contract or order confirmation. Information contained herein is periodically updated and changes will be incorporated into subsequent editions. If you have encountered an error, please notify Airspan Networks Inc. All specifications are subject to change without prior notice.

Product performance figures quoted within this document are indicative and for information purposes only.



Table of Contents

Copyright.....	2
Table of Contents.....	3
Summary of Figures.....	5
Summary of Tables.....	7
Warnings and Cautions.....	8
Human Exposure to Radio Frequencies.....	8
Radio Interference.....	8
Avoiding Radio Interference.....	8
Modifications.....	8
General.....	8
Safety.....	8
Warning Symbols.....	9
Service Information.....	9
UL Information.....	9
Lightning Protection.....	10
DECLARATION OF CONFORMITY.....	11
FCC Notice.....	12
Federal Communication Commission Notice.....	12
GPS Compliance.....	12
Maximum Output TX Power.....	13
Antenna Types.....	13
Air4G Antenna Usage.....	14
1 About this Guide.....	17
1.1 Purpose.....	17
1.2 Intended Audience.....	17
1.3 Conventions.....	17
1.4 Referenced Documentation.....	17
1.5 Organization of this Guide.....	17
2 Introduction.....	19
2.1 Air4G.....	19
2.2 Air4G Frequency Ranges.....	19
2.2.1 Architecture.....	20
3 Getting Started.....	23
3.1 Workflow of Installation.....	23
3.2 Air4G Installation Checklist.....	24
4 Verify Prerequisites.....	25
4.1 Verify Safety Requirements.....	25



Air4G Installation Guide



4.1.1	Warning of Hazardous Voltages	25
4.2	Verify Installation Requirements	26
4.2.1	Verify the Tools	26
4.2.2	Verify the Parts and Kits.....	26
4.2.3	Verify Components.....	31
5	Install Air4G.....	34
5.1	Pole mount configuration	34
5.2	Wall mount configuration.....	35
5.2.1	Mounting Examples.....	37
5.3	Air4G Connections	38
5.4	Install Air4G Antennas	38
5.4.1	Install Dual Slant Antenna.....	39
5.4.2	Install Quad Slant Antenna	40
5.4.3	Antenna Mounting Clamps for Dual and Quad Slant Antennae	40
5.5	Optional Mounting Antenna on Air4G	42
5.5.1	Variable Tilt Antenna.....	42
5.6	Antenna Connection.....	43
5.7	GPS Antenna Assembly.....	44
5.8	Install Junction Box (Optional)	45
5.8.1	Junction Box Installation	46
6	Connect and Manage Cables.....	48
6.1	Assemble Ethernet Connector	48
7	Set Power System.....	49
7.1	Power Input - DC.....	49
8	Appendix A.....	50
8.1	Review <i>Job Sheet</i>	50
8.2	Securing Fiber-optic Cable.....	50
8.3	Connecting the Fiber-optic Cable	52
9	Appendix C – Glossary of Terms	54
10	Appendix D – Installation Checklist.....	56
11	Appendix E	57
11.1	Revision History	57
11.2	Contact Information.....	57

Summary of Figures

Figure 1 – Air4G Hardware Components.....	21
Figure 2 – Air4G Functional Components.....	22
Figure 3 – Workflow of Installation	23
Figure 4 - PS – Air4G	28
Figure 5 – Air4G Base Station Unit, Ethernet termination	31
Figure 6 – Air4G Base Station Unit, RF ports	32
Figure 7 – Air4G Cable Assembly for GPS Antenna	33
Figure 8 - Lightning/Surge protector	33
Figure 9 - Junction box with pole assembly	33
Figure 10 – Pole Mounted Air4G Assembly.....	34
Figure 11 – Pole Mounted Air4G	35
Figure 12 – Wall Mounted Air4G.....	35
Figure 13 – Wall Mounted Air4G Wall Plate Details	36
Figure 14 - Wall mount.....	37
Figure 15 - GPS alternative assembly	37
Figure 16 - Air4G connections (bottom).....	38
Figure 17 – Air4G External Antenna Configuration	38
Figure 18 - Air4G Antenna Dual Slant Mast Mount Configuration	39
Figure 19 – Air4G Antenna Quad Slant Mast Mount Configuration.....	40
Figure 20 - Adjustable Mounting Kit, with Snaplock Stainless Steel Bands	41
Figure 21 - Adjustable Mounting Kit, with ‘V’ Blocks.....	42
Figure 22 - Variable tilt antenna	43
Figure 23 - Antenna mounted on Air4G	43
Figure 24 - GPS cable assembly prior to mounting	44
Figure 25 - Attach GPS antenna to RG58 cable.....	44
Figure 26 - GPS antenna assembled on bracket.....	45
Figure 27 - Junction box with mounting brackets assembled	45
Figure 28 - mounting bracket (2 required)	45
Figure 29 - Air4G assembly with optional junction box	47
Figure 30 – Ethernet connector cable termination	48
Figure 31 – Ethernet environmental connector assembly	48
Figure 32 – DC Power connection	49
Figure 33 - Secure fiber-optic cable, place tie	51
Figure 34 – Secure fiber-optic cable, pull tie.....	51
Figure 35 – Secure fiber-optic cable, snug tie	51
Figure 36 – Secure fiber-optic cable, cut excess tie	51
Figure 37 – Secure fiber-optic cable, use excess tie	52



Air4G Installation Guide



Figure 38 – Secure fiber-optic cable, re-use excess tie.....	52
Figure 39 - fiber-optic connector with dust cover	52
Figure 40 – dust cover removed	52
Figure 41 - Fiber-Optic Outdoor Connector Plug (multimode).....	53
Figure 42 - screw hand-tight	53
Figure 43 - Fiber-optic cable connected	53



Summary of Tables

Table 1 - Air4G FCC Maximum Output TX Power.....	13
Table 2 - Air4G ETSI Maximum Output TX Power	13
Table 3 - 700 MHz Antenna Types -Technical.....	13
Table 4 - 2.x GHz Antenna Types - Technical	14
Table 5 - 3.x GHz Antenna Types - Technical	14
Table 6 - Antenna arrays.....	15
Table 7 - Air4G frequency ranges.....	19
Table 8 - Air4G installation tools	26
Table 9 - Air4G installation parts and kits	26
Table 10 - Input Power for Air4G	28
Table 11 - Air4G wall mount installation parts	29
Table 12 - Air4G pole mount installation parts.....	29
Table 13 - Air4G additional parts and kits.....	29
Table 14 - Junction box (optional).....	30
Table 15 - Air4G 3.x physical dimensions.....	32
Table 16 - Air4G 2.x & 0707 physical dimensions	32
Table 17 - Antenna connection	44
Table 18 - Cable hole sizes.....	46
Table 19 - Checklist for Procedure	56



Warnings and Cautions

Human Exposure to Radio Frequencies

The Air4G (formally MacroMAXe) antennas should be installed and operated from a minimum distance of 2.4 meters (for 3.x & 0707) or 3.2 meters (for 2.x) from your body.

Radio Interference

This Air4G generates, uses, and can radiate radio frequency energy and, if not installed and used in accordance with the instructions, may cause harmful interference to radio communications. However, there is no guarantee that interference will not occur in a particular installation. If this equipment does cause harmful interference to radio or television reception, which can be determined by turning the equipment on and off, the technician is encouraged to try to correct the interference by performing one or more of the following measures:

- Re-orientate or relocate the antenna
- Increase separation between the BSs and/or End Device
- Connect the equipment to an outlet on a circuit different from that to which the power source is connected

Avoiding Radio Interference

- The Air4G must not be co-located or operating in conjunction with any antenna or other transmitter.
- Ensure a minimum of 1-meter separation between co-located antennas of Air4G units.

Modifications

Any changes and modifications to this device that are not expressly approved by Airspan Networks may void the user's authority to operate the equipment.

General

- Only qualified personnel should be allowed to install, replace, and service the equipment.
- The device cannot be sold retail, to the general public or by mail order. It must be sold to operators.
- Installation must be controlled.
- Installation must be performed by licensed professionals.
- Installation requires special training. The Air4G radio and antenna should be installed ONLY by experienced installation professionals who are familiar with local building and safety codes and, wherever applicable, are licensed by the appropriate government regulatory authorities. Failure to do so may void Airspan's WiMAX product warranty and may expose the end user or the service provider to legal and financial liabilities. Airspan and its resellers or distributors are not liable for injury, damage or violation of regulations associated with the installation of outdoor units or antennas.

Safety

1. Read this User Manual and follow all operating and safety instructions.
2. Keep all product information for future reference.
3. This product is supplied with a grounding power plug. Do not defeat this important safety feature.
4. **Warning:** High voltages exist inside the product - do not remove the lid or base: No user serviceable parts inside.
5. Position the power cord to avoid possible damage; do not overload wall outlets.

6. Do not place this product on or near a direct heat source, and avoid placing objects on the terminal.
7. Do not operate this device near water or in a wet location.
8. Use only a damp cloth for cleaning. Do not use liquid or aerosol cleaners. Disconnect the power before cleaning.
9. The units should not be located near power lines or other electrical power circuits.
10. The radio transceiver must be properly grounded to protect against power surges and accumulated static electricity. It is the user's responsibility to install this device in accordance with the local electrical codes.
11. Installation of the Air4G must be contracted to a professional installer.
12. Disconnect Device. The socket outlet should be easily accessible in case you have to disconnect the device.
13. When installed in the final configuration, the product must comply with the applicable Safety Standards and regulatory requirements of the country in which it is installed. If necessary, consult with the appropriate regulatory agencies and inspection authorities to ensure compliance.

Warning Symbols

The following symbols may be encountered during installation or troubleshooting. These warning symbols mean danger. Bodily injury may result if you are not aware of the safety hazards involved in working with electrical equipment and radio transmitters. Familiarize yourself with standard safety practices before continuing.



Electro-Magnetic Radiation



High Voltage

Service Information

Refer all repairs to qualified service personnel. Do not remove the covers or modify any part of this device, as this will void the warranty.

Disconnect the power to this product and return it for service if the following conditions apply:

- a. The terminal does not function after following the operating instructions outlined in this manual.
- b. Liquid has been spilled, a foreign object is inside, or the terminal has been exposed to rain.
- c. The product has been dropped or the housing is damaged.

Locate the serial number of the terminal, antenna, and transceiver and record these on your registration card for future reference. Use the space below to affix serial number stickers. Also record the MAC address, located on the back of the terminal.

UL Information

- The equipment must be properly grounded according with NEC and other local safety code requirements.

- Reminder to all the BWA system installers: Attention to Section 820-40 of the NEC which provides guidelines for proper grounding and, in particular, specifies that the cable ground shall be connected to the grounding system of the building, as close to the point of cable entry as is practical.



Lightning Protection

WARNING: The following notes are general recommendations for the system. The wireless equipment should be installed by a qualified professional installer and must follow local and national codes for electrical grounding and safety. Failure to meet safety requirements and/or use of non-standard practices and procedures could result in personal injury and damage to equipment. A direct lightning strike may cause serious damage even if these guidelines are followed.

All outdoor wireless equipment is susceptible to lightning damage from a direct hit or induced current from a near strike. Lightning protection and grounding practices in local and national electrical codes serve to minimize equipment damage, service outages, and serious injury. Reasons for lightning damage are summarized as:

- Poorly grounded tower/antenna sites that can conduct high lightning strike energy into equipment.
- Lack of properly installed lightning protection equipment that can cause equipment failures from lightning induced currents.

A lightning protection system provides a means by which the energy may enter earth without passing through and damaging parts of a structure. A lightning protection system does not prevent lightning from striking; it provides a means for controlling it and preventing damage by providing a low resistance path for the discharge of energy to travel safely to ground. Improperly grounded connections are also a source of noise that can cause sensitive equipment to malfunction.

A good tower grounding system disperses most of the surge energy from a tower strike away from the building and equipment.

To limit the equipment damage due to a lightning strike, the following practices are recommended for the wireless system:

- Provide direct grounding from the antenna mounting bracket, the radio and antenna and the lightning arrestors to the same ground point at the base of the tower or a ground bus on the building. Use the grounding screws on the antenna bracket and the radio and antenna for terminating the ground wires.
- The AC wall outlet ground must be connected to the same grounding system as the BS.

DECLARATION OF CONFORMITY

European Community, Switzerland, Norway, Iceland, and Liechtenstein

Declaration of Conformity with Regard to the R&TTE Directive 1999/5/EC

English:

This equipment is in compliance with the essential requirements and other relevant provisions of Directive 1999/5/EC.

Deutsch:

Dieses Gerät entspricht den grundlegenden Anforderungen und den weiteren entsprechenden Vorgaben der Richtlinie 1999/5/EU.

Dansk:

Dette udstyr er i overensstemmelse med de væsentlige krav og andre relevante bestemmelser i Direktiv 1999/5/EF.

Español:

Este equipo cumple con los requisitos esenciales así como con otras disposiciones de la Directiva 1999/5/EC.

Greek:

ΜΕ ΤΗΝ ΠΑΡΟΥΣΑ Airspan ΔΗΛΩΝΕΙ ΟΤΙ Ο ΕΞΟΠΛΙΣΜΟΣ ΣΥΜΜΟΡΦΩΝΕΤΑΙ ΠΡΟΣ ΤΙΣ ΟΥΣΙΩΔΕΙΣ ΑΠΑΙΤΗΣΕΙΣ ΚΑΙ ΤΙΣ ΛΟΙΠΕΣ ΣΧΕΤΙΚΕΣ ΔΙΑΤΑΞΕΙΣ ΤΗΣ ΟΔΗΓΙΑΣ 1999/5/ΕΚ.

Français:

Cet appareil est conforme aux exigences essentielles et aux autres dispositions pertinentes de la Directive 1999/5/EC.

Íslenska:

Þessi búnaður samrýmist lögboðnum kröfum og öðrum ákvæðum tilskipunar 1999/5/ESB.

Italiano:

Questo apparato é conforme ai requisiti essenziali ed agli altri principi sanciti dalla Direttiva 1999/5/EC.

Nederlands:

Deze apparatuur voldoet aan de belangrijkste eisen en andere voorzieningen van richtlijn 1999/5/EC.

Norsk:

Dette utstyret er i samsvar med de grunnleggende krav og andre relevante bestemmelser i EU-directiv 1999/5/EC.

Português:

Este equipamento satisfaz os requisitos essenciais e outras provisões da Directiva 1999/5/EC.

Suomalainen:

Tämä laite täyttää direktiivin 1999/5/EY oleelliset vaatimukset ja on siinä asetettujen muidenkin ehtojen mukainen.

Svenska:

Denna utrustning är i överensstämmelse med de väsentliga kraven och andra relevanta bestämmelser i Direktiv 1999/5/EC.

Român:

Acest echipament este în conformitate cu cerințele esențiale și alte prevederi relevante ale Directivei 1999/5/CE.

The Declaration of Conformity related to this product can be obtained from product_management@Airspan.com

FCC Notice

Federal Communication Commission Notice

This equipment has been tested and found to comply with the limits for a Class A digital device, pursuant to part 15 of the FCC Rules. These limits are designed to provide reasonable protection against harmful interference when the equipment is operated in a commercial environment. This equipment generates, uses, and can radiate radio frequency energy and, if not installed and used in accordance with the instruction manual, may cause harmful interference to radio communications. Operation of this equipment in a residential area is likely to cause harmful interference in which case the user will be required to correct the interference at his/her own expense.

Fixed and base stations transmitting a signal with an emission bandwidth greater than 1 MHz must not exceed an ERP of 1000 watts/MHz and an antenna height of 305 m HAAT, except that antenna heights greater than 305 m HAAT are permitted if power levels are reduced below 1000 watts/MHz ERP.

GPS Compliance

The GPS is in compliance with the essential requirements and other relevant provisions of Directive 1999/5/EC."

The GPS complies with the following EMC Common Regulatory Testing standards:

- EN55022: Radiated and Conducted Emissions
- CISPR 22: Class B
- EN 50081-1: Generic Emissions Class B
- EN 50082-1: Generic Immunity Class B
- EN 61000-4-2: Electrostatic Discharge Immunity
- EN 61000-4-3: Radiated RF EM Field Immunity Test
- EN 61000-4-4: Electrical Fast Transient/Burst Test
- EN 61000-4-6: Conducted Immunity
- EN 61000-4-8: Magnetic Field Immunity



Note: A GPS is required for synchronizing between TDD sectors.



Note: A GPS Lightning/Surge protector is required. (ordered separately)

Maximum Output TX Power

Table 1 - Air4G FCC Maximum Output TX Power

Frequency Band	FCC		Rest of the World		Antenna Gain
	TX	EIRP	TX	EIRP	
700 MHz	41.6 dBm	55.1 dBm	41.6 dBm	55.1 dBm	13.5 dBi
2.56 GHz	43.28 dBm	61.28dBm	43 dBm	61 dBm	18 dBi
3.65 GHz	36.88 dBm	38.88 dBm	37 dBm	39 dBm	2 dBi

Table 2 - Air4G ETSI Maximum Output TX Power

Frequency Band	ETSI		Rest of the World		Antenna Gain
	TX	EIRP	TX	EIRP	
698-746 MHz	41.6 dBm	55.1 dBm	41.6 dBm	55.1 dBm	13.5 dBi
2290-2350 MHz	43 dBm	55.5 dBm	43 dBm	55.5 dBm	12.5 dBi
2340-2400 MHz	43 dBm	53 dBm	43 dBm	53 dBm	10.0 dBi
2496-2570 MHz	43 dBm	61 dBm	43 dBm	61 dBm	18.0 dBi
2560-2630 MHz	43 dBm	61 dBm	43 dBm	61 dBm	18.0 dBi
2620-2690 MHz	43 dBm	61 dBm	43 dBm	61 dBm	18.0 dBi
3300-3400 MHz	40 dBm	58 dBm	40 dBm	58 dBm	18.0 dBi
3400-3500 MHz	40 dBm	58 dBm	40 dBm	58 dBm	18.0 dBi
3500-3600 MHz	40 dBm	58 dBm	40 dBm	58 dBm	18.0 dBi
3600-3700 MHz	40 dBm	58 dBm	40 dBm	58 dBm	18.0 dBi
3650-3675 MHz	40 dBm	42 dBm	40 dBm	42 dBm	2 dBi
3700-3800 MHz	40 dBm	58 dBm	40 dBm	58 dBm	18.0 dBi



Caution: Do not set maximum output TX power to higher than local regulations.

Antenna Types

Table 3 - 700 MHz Antenna Types -Technical

Type	Frequency range	Gain	Part number
60° 13.5 dBi Dual X-Polar	698 - 806 MHz	13.5 dBi	SEC60Q-700-13.5-1
90° 12.5 dBi Dual X-Polar	698 - 806 MHz	12.5 dBi	SEC90Q-700-12.5-1
OMNI Directional	698-746 MHz	6 dBi	MT-221024/NV
OMNI Directional	746-806 MHz	6.5 dBi	MT-221023/NV
Mounting kit for Dual X-Polar Antennas			MNT-KT-Dual-1

Table 4 - 2.x GHz Antenna Types - Technical

Type	Frequency range	Gain	Part number
65° Quad X-Polar	2.3-2.7 GHz	18.0 dBi	SEC60Q-2.X-RC-1
90° Quad X-Polar	2.3-2.7 GHz	17.0 dBi	SEC90Q-2.X-RC-1
Mounting kit for Quad X-Polar Antennas			MNT-KT-Quad-1
60° Dual Slant X-Polar	2.3-2.7 GHz	18.0 dBi	SEC60X-2.X-RC-1
90° Dual Slant X-Polar	2.3-2.7 GHz	17.0 dBi	SEC90X-2.X-RC-1
Mounting kit for Dual X-Polar Antennas			MNT-KT-Dual-1
Omni 10dBi Vertical External	2.3-2.49 GHz	10 dBi	ANT2300OV10-360

Table 5 - 3.x GHz Antenna Types - Technical

Type	Frequency range	Gain	Part number
60° Quad X-Polar	3.3 - 3.8 GHz	18.0 dBi	SEC60Q-3.5-RC-1
90° Quad X-Polar	3.3 - 3.8 GHz	17.0 dBi	SEC90Q-3.5-RC-1
Mounting kit for Quad X-Polar Antennas			MNT-KT-Quad-1
60° Dual Slant X-Polar	3.3 - 3.8 GHz	18.0 dBi	SEC60X-3.5-RC-1
90° Dual Slant X-Polar	3.3-3.8 GHz	17.0 dBi	SEC90X-3.5-RC-1
Mounting kit for Dual X-Polar Antennas			MNT-KT-Dual-1
Omni Reg Compl Vertical Sector	3.3 – 3.5 GHz	10.0 dBi	OMNIV-3.4-RC-2

Air4G Antenna Usage

Air4G has four (4) RF ports that can be connected to either:

- A single four-port antenna
- Two two-port antennas
- Four single-port antennas



Note: Appropriate mounting kit for the dual and quad port antennas are required (ordered separately).

- Quad port cross polarized (X-Pol) antenna with four (4) ports – connected via 4 RF jumper cables to Air4G.
- Dual slant cross polarized (X-Pol) antenna with two (2) ports - connected via 2 RF jumper cables to Air4G.
- Omni antennas – for 360 degree coverage using a single Air4G - requires an Omni antenna for each receiver – 2 or 4 Omni antennas.



Note: The Omni antennas must be separated – with at least one meter separation from each other (in 2.X and in 3.X GHz)

- Fixed tilt dual/quad port antennas (where the tilt is set by the way the mounting kit is installed).



Note: Required mounting kits for fixed tilt dual/quad port antennas are ordered separately.

- Manual Electric Tilt (MET) dual/quad antennas - a variable tilt antenna available for mounting directly on the Air4G with no need for physical tilting of the antenna.

The following table describes different antenna arrays when using either two (2) receivers or four (4) receivers:

Table 6 - Antenna arrays

Frequency Band	# of Receivers	Sector	Antenna Type	# of Antennas
700 MHz	2	60°	698 - 806 MHz 60° 13.5 dBi Dual X-Polar	1
700 MHz	4	60°	698 - 806 MHz 60° 13.5 dBi Dual X-Polar	2
2.3 GHz	2	65°	2.3-2.7 GHz 60° Dual Slant X-Polar	1
2.3 GHz	4	65°	2.3-2.7 GHz 60° Quad X-Polar	1
2.5 GHz	2	65°	2.3-2.7 GHz 60° Dual Slant X-Polar Antenna	1
2.5 GHz	4	65°	2.3-2.7 GHz 60° Quad X-Polar	1
3.3-3.8 GHz	2	65°	3.3-3.8 GHz 60° Dual Slant X-Polar	1
3.3-3.8 GHz	4	65°	3.3-3.8 GHz 60° Quad X-Polar	1
700 MHz	2	90°	698 - 806 MHz 90° 12.5 dBi Dual X-Polar	1
700 MHz	4	90°	698 - 806 MHz 90° 12.5 dBi Dual X-Polar	2
2.3 GHz	2	90°	2.3-2.7 GHz 90° Dual Slant X-Polar	1
2.3 GHz	4	90°	2.3-2.7 GHz 90° Quad X-Polar	1
2.5 GHz	2	90°	2.3-2.7 GHz 90° Dual Slant X-Polar	1
2.5 GHz	4	90°	2.3-2.7 GHz 90° Quad X-Polar	1
3.3-3.8 GHz	2	90°	3.3-3.8 GHz 90° Dual Slant X-Polar	1
3.3-3.8 GHz	4	90°	3.3-3.8 GHz 90° Quad X-Polar	1
2.3 GHz	2	360°	2.3-2.49 GHz Omni 10 dBi Vertical External Antenna	2
2.3 GHz	4	360°	2.3-2.49 GHz Omni 10 dBi Vertical External Antenna	4
2.5 GHz	2	360°	Generic Omni	2
2.5 GHz	4	360°	Generic Omni	4



Air4G Installation Guide



3.3-3.4 GHz	2	360°	3.3-3.5 GHz Omni Reg Compl Vertical Sector	2
3.3-3.4 GHz	4	360°	3.3-3.5 GHz Omni Reg Compl Vertical Sector	4
3.4-3.6 GHz	2	360°	3.4-3.6 GHz Omni Reg Compl Vertical Sector	2
3.4-3.6 GHz	4	360°	3.4-3.6 GHz Omni Reg Compl Vertical Sector	4
3.6-3.8 GHz	2	360°	3.6-3.8 GHz Omni Reg Compl Vertical Sector	2
3.6-3.8 GHz	4	360°	3.6-3.8 GHz Omni Reg Compl Vertical Sector	4

1 About this Guide

This section discusses the purpose, intended audience, conventions, referenced documentation and organization for this guide.

1.1 Purpose

This guide provides the workflow and step-by-step procedures for Installing the Air4G (formally MacroMAXe). These procedures include:





- Verify Prerequisites
- Install the Air4G
- Connect and Manage Cables
- Set Power System

1.2 Intended Audience

This guide is intended for persons who are responsible for Installing the Air4G. These persons should have a working knowledge of the WiMAX system.

1.3 Conventions

This document uses the following informational conventions.

Icon	Description
	Checkpoint: Marks a point in the workflow where there may be an exit or branch to some other procedure. At each Checkpoint the reason for an exit or branch is given along with specific directions to locate the entry point in the other procedure.
	Reference: Gives a resource in the workflow that may be needed to complete a procedure along with specific directions to use the resource.
	Caution: Describes a possible risk and how to lessen or avoid the risk.
	Advice: Provides a recommendation based on best practice.
	Note: Provides useful information.

1.4 Referenced Documentation

- Air4G Product Description

1.5 Organization of this Guide

This guide is organized into the following Sections:

- About this Guide
- Introduction
- Get Started
- Verify Prerequisites



Air4G Installation Guide



-
- Install the Air4G
 - Connect and Manage Cables
 - Set Power System
 - Appendixes [Review Job Sheet, Securing & Connecting the Fiber-Optic cable, Glossary of Terms, Installation Checklist, Contact information and Revision history]

2 Introduction

This section provides a descriptive overview of the Air4G (formally MacroMAXe) (3.x, 2.x and 0707) and its place in the product suite.

2.1 Air4G

Air4G is a highly integrated macro-cell base station with all-in-one packaging of RF and baseband components. Air4G includes integrated quad RF transceivers to support four channel diversity and MIMO. It is available as an all outdoor solution for Mobile WiMAX applications to minimize physical footprint and operator OPEX.

Air4G fully supports the interoperable R6 reference point for interworking with ASN Gateways. Air4G also has a “Stand Alone” mode for fixed/nomadic applications which do not require seamless handover. When Air4G is used in “Stand Alone” mode there is no need for an ASN Gateway. Air4G supports IP CS and Ethernet CS. It even supports a hybrid mode where both IP CS and Ethernet CS (including VLAN support) are supported. Air4G implements dual 40dBm (10W) transmitters in 2.x GHz, dual 38 dBm (6.3W) in 700MHz and dual 37dBm (5W) transmitters in 3.x GHz band.

Air4G is an outdoor radio that is mounted outside on a pole or wall. Air4G is available in numerous frequency bands and in numerous channels see: [Air4G Frequency Ranges](#).

Air4G is managed by an SNMP-based network management system (Netspan) using standard and proprietary MIBs. Basic management can be performed using any standard Web browser.



Note: For management refer to Air4G Commissioning documentation.

2.2 Air4G Frequency Ranges

The table below lists the frequency range of Air4G variants currently available. This table will grow as more variants become available.

Table 7 - Air4G frequency ranges

Band	Variant	Lower Frequency	Upper Frequency	Channel Bandwidth	Duplex
700 MHz	0707	698 MHz	746 MHz	<ul style="list-style-type: none"> ➤ 3.5MHz ➤ 5MHz ➤ 7MHz ➤ 10MHz 	TDD
2.3 GHz	2310 Lo	2290 MHz	2350 MHz	<ul style="list-style-type: none"> ➤ 3.5MHz ➤ 5MHz ➤ 7MHz ➤ 10MHz 	TDD
	2310 Hi	2340 MHz	2400 MHz		
2.5 GHz	2510 Lo	2496 MHz	2570 MHz	<ul style="list-style-type: none"> ➤ 3.5MHz ➤ 5MHz ➤ 7MHz ➤ 10MHz 	TDD
	2510 Mid	2560 MHz	2630 MHz		
	2510 Hi	2620 MHz	2690 MHz		

Band	Variant	Lower Frequency	Upper Frequency	Channel Bandwidth	Duplex
3.x GHz	3305	3300 MHz	3400 MHz	<ul style="list-style-type: none"> ➤ 3.5MHz ➤ 5MHz ➤ 7MHz ➤ 10MHz 	TDD
	3405	3400 MHz	3500 MHz	<ul style="list-style-type: none"> ➤ 3.5MHz ➤ 5MHz ➤ 7MHz ➤ 10MHz 	TDD
	3505	3500 MHz	3600 MHz	<ul style="list-style-type: none"> ➤ 3.5MHz ➤ 5MHz ➤ 7MHz ➤ 10MHz 	TDD
	3605	3600 MHz	3700 MHz	<ul style="list-style-type: none"> ➤ 3.5MHz ➤ 5MHz ➤ 7MHz ➤ 10MHz 	TDD
	3705	3700 MHz	3800 MHz	<ul style="list-style-type: none"> ➤ 3.5MHz ➤ 5MHz ➤ 7MHz ➤ 10MHz 	TDD

2.2.1 Architecture

A highly flexible and scalable WiMAX Base Station, the Air4G is capable of supporting Mobile WiMAX profiles across multiple frequency bands.



Note: The following is for illustration only; actual layout may differ as infrastructure is installation-specific.



Note: Air4G must be properly grounded according with NEC and other local safety code requirements.

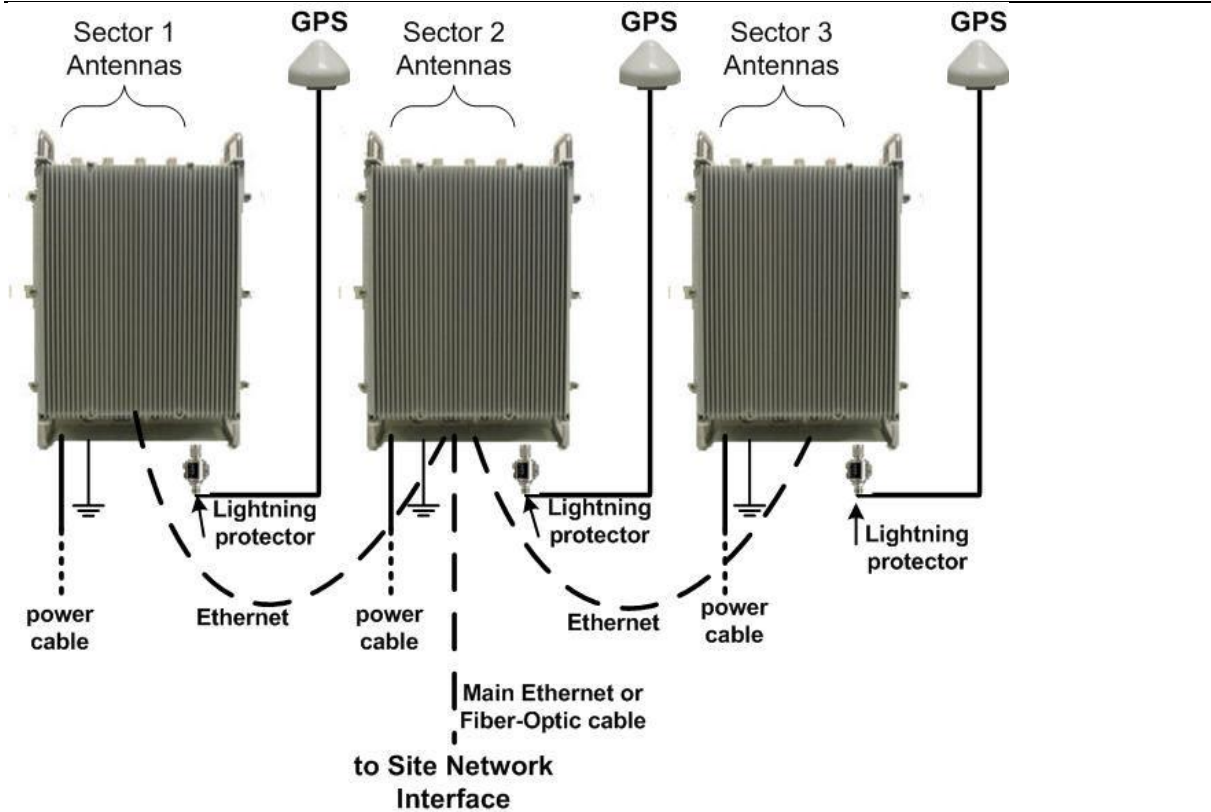







Figure 1 – Air4G Hardware Components

-  **Note:** Air4G can also be connected via a LAN Switch for greater Failsafe protection.

-  **Note:** Illustration above is of single Ethernet cable or Fiber-Optic cable for connection.

-  **Note:** When the Fiber-Optic cable connection is employed the Ethernet cable connection (Eth 1) is disabled.

-  **Note:** Auto-negotiation must always be enabled on the core network side.

-  **Note:** Illustration above displays remote GPS antennae option.

The Air4G is a fully integrated all outdoor base station sector that contains all RF, Baseband, GPS Synchronization and 3-sector aggregation functionality. In one box it comprises the following functional elements:

- Quad Receiver / Dual Transmitter
- SDR Card
- Ethernet Switch
- GPS

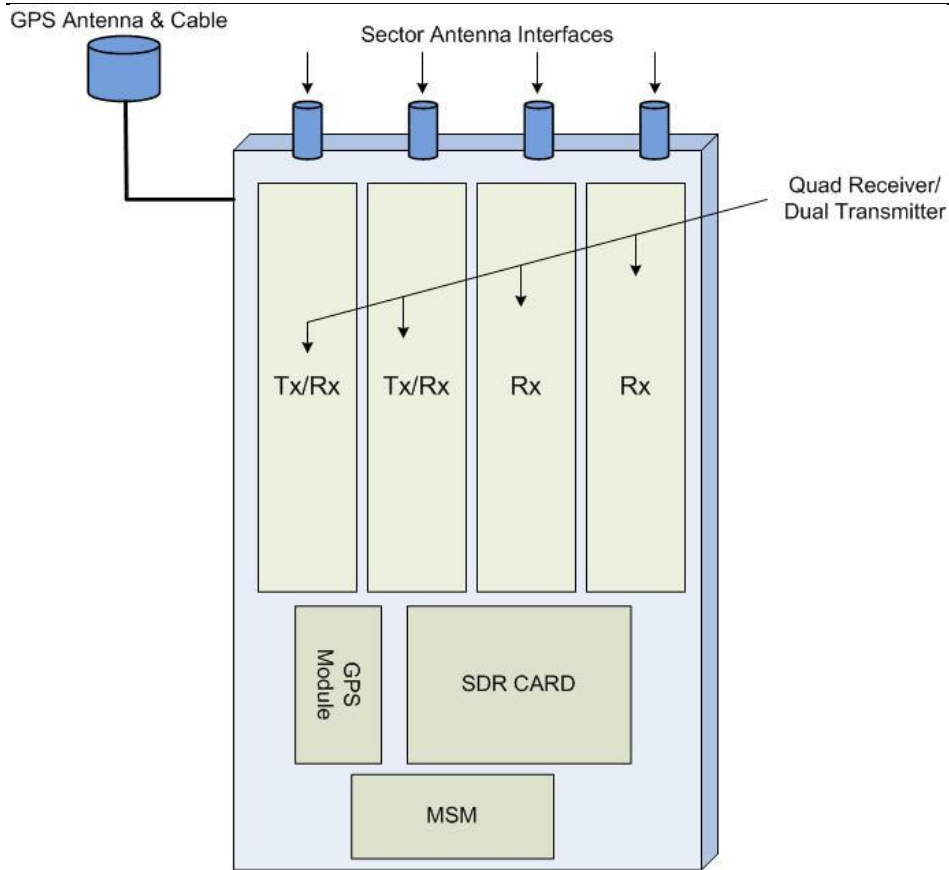

Figure 2 – Air4G Functional Components

3 Getting Started

3.1 Workflow of Installation

The Workflow to install the Air4G is shown in the following diagram:



Figure 3 – Workflow of Installation



Caution: Antennas 1 & 2 Tx/Rx must be connected and attached before Air4G is powered on.



3.2 Air4G Installation Checklist

Plan the installation of the Air4G by using the Installation Checklist, which you can find as a removable job aid in Appendix A for this guide.

4 Verify Prerequisites

Prior to installing the Air4G, verify the required safety, power, tools, parts and components.



Reference: Set up requirements for the installation is detailed in the *Job Sheet*, see [Appendix A](#) for this guide.

4.1 Verify Safety Requirements

Read and follow all warning notices and instructions marked on the product or included in this manual.

When installed in the final configuration, the product must comply with the applicable Safety Standards and regulatory requirements of the country in which it is installed. If necessary, consult with the appropriate regulatory agencies and inspection authorities to ensure compliance.

Ascertain the radiation hazards when working in an environment close to other antennas and Electromagnetic fields, e.g. working on towers with other microwave transmitters etc. and act accordingly.

4.1.1 Warning of Hazardous Voltages

On AC installations, hazardous voltages exist. Use caution when verifying or working with AC power. Remove metal jewelry that could come into contact with AC power.

On DC sections, short circuiting the low voltage, low impedance circuits can cause severe arcing that may result in burns or eye damage. Remove rings, watches etc. to avoid shorting DC circuits.



Note: Airspan products do not contain hazardous substances (as defined in UK Control of Substances Hazardous to Health Regulations 1989 and the Dangerous Substances Regulations 1990). At the end of any Airspan products life cycle, the customer should consult with Airspan to ensure that the product is disposed of in conformance with the relevant regulatory requirements.



Caution: Any modifications to this device not expressly authorized by the manufacturer could void the user's authority to operate this device.

4.2 Verify Installation Requirements

4.2.1 Verify the Tools



Table 8 - Air4G installation tools

Tool
Large Crosshead Screw driver Phillips # 3 or Pozidrive # 3
Small flat blade screwdriver
Medium flat blade screwdriver
13mm or 1/2 inch open ended spanner
10mm or 13/32 inch open ended spanner
Wire strippers
Wire cutters
Ring terminals crimp tool
RJ45 crimp tool

4.2.2 Verify the Parts and Kits

Table 9 - Air4G installation parts and kits

Air4G Base Station parts	Consisting of
1 x Air4G unit	Base station unit
3 x RJ45 Weatherproof Connector Covers	Weatherproof connector covers for use with standard cat 5 RJ45 network connections.
1 x mains cable 14AWG x2 (ordered separately)	30 meter lead with M17 3 pole plug
When distance from outdoor Power supply to Base Station is over 30 meters additional power cable must be connected via a junction box (ordered separately) for total distance of up to 130 meters.	
	14AWG x2 (ordered separately) – up to 40 meters
	12AWG x6 (ordered separately) – up to 100 meters
1 x Ethernet RJ45 environmental shroud	LTW IP68 or Amphenol environmental connector
1 x Sunshield fixing kit (optional) (ordered separately) including quad antenna adaptor brackets (x 2).	M8 x 20 Hex Cap screws - 12 M8 plain washers - 12 M8 spring washers – 12 M8 Hex nuts - 4 M12 x 20 screws – 4 M12 nuts – 4 M12 flat washers – 4 M12 spring washers - 4

Air4G Base Station parts	Consisting of
	Note: The Sunshield brackets are only applicable for antennas that utilize Mechanical Electric Tilt (MET). i.e. – Argus-SSPX310F.
	Warning: A Sunshield is mandatory for temperatures of above 45°.
1 x Air4G installation mount kit (ordered separately)	M8 x 20 Hex Cap screws – 8 M8 Hex nuts - 4 M8 plain washers – 8 M8 spring washers - 8
Pole Mount Bracket Assembly: Dia. 120-230 mm – top & bottom – plus fixing accessories. (ordered separately)	Accessories included
Pole Mount Bracket Assembly: Dia. 60-120 mm – top & bottom – plus fixing accessories. (ordered separately)	Accessories included
1 x earth kit	1 x M5 screws 1 x M5 washers 1 x M5 spring washers Alternative: SEMS screw (includes 2 washers)
GPS antenna & accessories (each ordered separately)	1x GPS Antenna. An active GPS antenna which, by using the appropriate mounting bracket, can be used with Air4G for network synchronization. For mounting directly to the top of Air4G, this GPS Antenna should be used in conjunction with Air4G GPS Antenna mounting bracket w/Handle pre-assembled on the Air4G and the 5m GPS Cable RG58 TNC-TNC. When mounting remotely from the base station unit, this antenna should be used in conjunction with the Remote GPS Antenna Mounting Bracket (GPS-MNT-1) and the 16m GPS Cable RG58 TNC-TNC. 80cm or 16m Cable Assembly - 80cm (CBL-GPS-TNC-0.8-1) or 16m (CBL-GPS-TNC-16-1) RG58 cable. 16m connects remote mounted GPS Antenna (GPS-ANT-1) to the Air4G via TNC connectors. The 80cm, cable for mounting GPS directly to the top of Air4G.
GPS Lightning/Surge protector (ordered separately)	1x Lightning/Surge protector
AC/DC Power Supply (PS)	Indoor power converter for 700 MHz
	Indoor power converter for 2.xGHz

Air4G Base Station parts	Consisting of
	Outdoor power converter for 3.xGHz
Type-IC DC Power Cable	Available either in - 10, 15 or 30 meter lengths. Additional lengths available.
ODC Twin Fiber Cable (Multimode) (optional) (ordered separately)	Available either in - 10, 15, 30, 50, 75 or 100 meter lengths.  Note: Maximum up to 500 meters as this is a multimode interface.
Multimode fiber pigtail cable (not included) (optional) (ordered separately)	Multimode fiber pigtail cable – ODC - LC connector. Terminates the outdoor fiber cable and provides an indoor LC connector. 2 meter length.
Grounding Cable (required) (not included)	Circular earth braid, 120A current (16 mm ²), jacketed or not with cable size = AWG 4 – 6 with lug (terminal) on enclosure side with hole M6

The Air4G power supply (PS) can be installed with various cable lengths according to the site requirements. The cable lengths are determined by the length of the run between the PS and the Air4G. Use the following table to determine the required power supply output to ensure proper operation of the Air4G.

Table 10 - Input Power for Air4G

	Air4G 2x10 (2.3-2.7 GHz) & Air4G 0707 (698-746 MHz)	Air4G 3x05 (3.3-3.38 GHz)
Input Voltage to Air4G (1)	-38 VDC to -60 VDC	-38 VDC to -60 VDC
PS output Voltage – 30 meter cable (2)	-42 VDC min	-41 VDC min
PS output Voltage – 75 meter cable (2)	-50 VDC min	-46 VDC min
PS output Voltage – 100 meter cable (2)	-53 VDC min	-49 VDC min

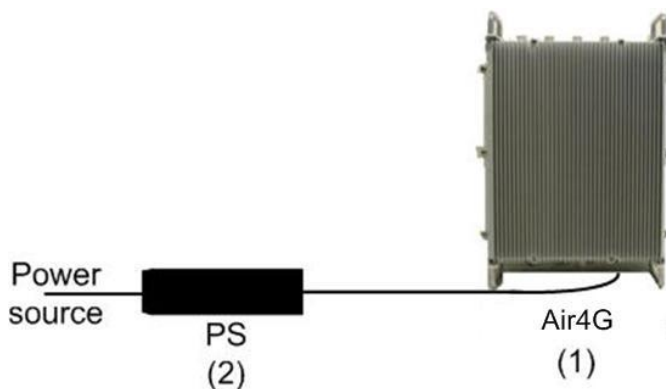

Figure 4 - PS – Air4G

Table 11 - Air4G wall mount installation parts





Parts		Images
1	Wall Plate	
2	Top Hanger	
3	Lower Hanger	
4	GPS Antenna mounting bracket w/Handle (pre-assembled)	
5	Handle (pre-assembled)	

Table 12 - Air4G pole mount installation parts



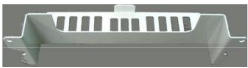







Parts		Images
 Note: in addition to the Wall mounting kit.		
1	Top & Lower Pole Strap (x2) for 120 > 230 MM	
 Note: in addition to the Wall mounting kit.		
2	Pole bracket for 60 > 120 MM	

Table 13 - Air4G additional parts and kits

Additional Common Accessories (not provided by Airspan)
Spare RJ45 connectors
Cable ties
Ring terminal for earth strap. M5 / M6
Earth strap cable (4-6 mm) (yellow and green cable)
Weatherproof / Outdoor mains cable splice kit or termination box.

Table 14 - Junction box (optional)

Optional Junction Box	Consisting of
1 x Junction box (ordered separately)	Junction box
1 x PG11 Weatherproof gland (connector), included with junction box	Weatherproof connector 
1 x PG16 Weatherproof gland (connector) , included with junction box	Weatherproof connector 
1 x PG29 Weatherproof gland (connector) , included with junction box	Weatherproof connector 
Additional power cable	14AWG x2 (ordered separately) – up to 40 meters
	12AWG x6 (ordered separately) – up to 100 meters
2x mounting bracket(s) for pole and wall mounting	Bracket (x2) 
2x pole bands (stainless steel), as required, supplied.	60 – 80 mm (2 ¼") 

Optional Junction Box	Consisting of
2x pole bands (stainless steel), as required, supplied.	80 – 100 mm (3 1/2") 
Mounting screws – for mounting brackets to junction box.	EJOT WN1412 – K50 x 12 – 4 supplied.
Wall mounting fasteners	Hole size = 7 mm (not supplied - customer responsibility)
Sufficient cable wires ties, as required	(not supplied - customer responsibility)

4.2.3 Verify Components

Air4G is shown below from the Ethernet termination and RF port end views respectively.



Figure 5 – Air4G Base Station Unit, Ethernet termination



Figure 6 – Air4G Base Station Unit, RF ports

4.2.3.1 Physical Dimensions

Air4G BS is in an all outdoor enclosure.

Table 15 - Air4G 3.x physical dimensions

Parameter	Value	Comment
Height	410 mm (16.14 inches)	The physical dimensions exclude handles and connectors.
Width	350 mm (13.78 inches)	
Depth	155 mm (6.10 inches)	
Weight	Aprox. 17 kg (37.47 lbs.)	

Table 16 - Air4G 2.x & 0707 physical dimensions

Parameter	Value	Comment
Height	410 mm (16.14 inches)	The physical dimensions exclude handles and connectors.
Width	350 mm (13.78 inches)	
Depth	170 mm (6.69 inches)	
Weight	Aprox. 17.6 kg (38.80 lbs.)	

RF Ports for antenna connections are N-Type Female connectors located on the top of the Air4G enclosure. Adjacent to these are SMA connectors used for RF monitoring purposes during installation / maintenance. For normal operation, these are covered with a weatherproof cap.

A 16m RG58 cable connects a remote mounted GPS antenna to the Air4G or 80cm cable for connection directly on the Air4G by way of TNC connectors. Alternatively, an 80cm, cable connects the GPS directly to the top of Air4G. The cable assembly for the remote GPS antenna is shown below.



Figure 7 – Air4G Cable Assembly for GPS Antenna

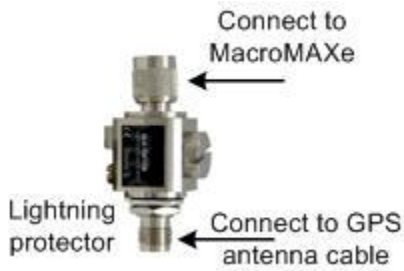

Figure 8 - Lightning/Surge protector

4.2.3.2 Junction Box (Optional)

The Junction box (optional) is an outdoor enclosure that measures 152 mm (6 in.) in height, 170 mm (6.70 in.) in width and 95 mm (3.74 in.) in depth. The unit is shown below with the pole mounting bands assembled. The Junction box is required when the distance from the outdoor Power supply to Base Station is **over** 30 meters for total distance of up to 130 meters.



Note: If – 48 volt DC can be verified and guaranteed the Junction box may not be required. Contact customer support to determine.

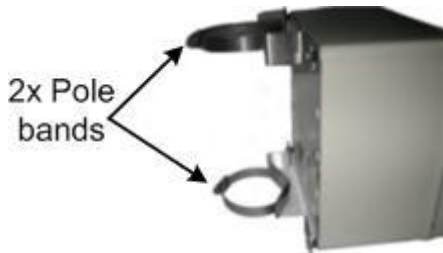

Figure 9 - Junction box with pole assembly

5 Install Air4G

Install the Air4G base station by pole mount, wall mount, or single point. The Air4G can be deployed as a remote radio head (RRH) connected to a pair of single (usually vertically polarized) or single dual independently mounted antennas via standard RF coaxial cables. Antennas are positioned with up to 10 wavelengths horizontal separation to give optimal Downlink and Uplink MIMO performance.



Caution: Proper local rigging and hoisting practices should be followed when installing the Air4G. The pre-assembled handles are **not** to be used for hanging, attaching or hoisting the unit into place. The handles are for hand carrying purposes only.

5.1 Pole mount configuration

The following image shows the pole mount assembly.

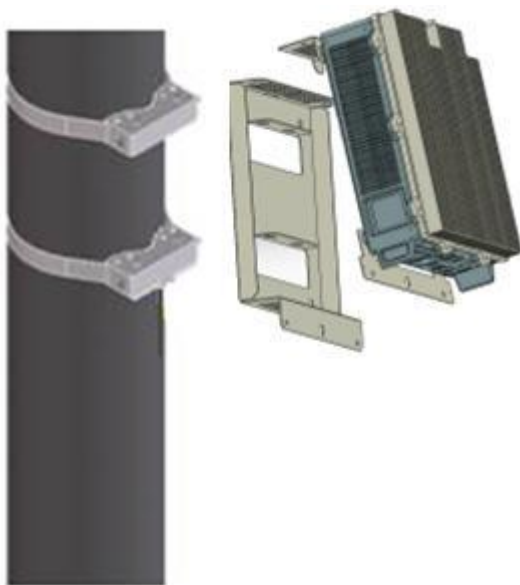

Figure 10 – Pole Mounted Air4G Assembly

To mount the Air4G in the pole mount configuration (for poles 120 > 230 mm), perform the following steps:

1. Attach the two (2) PMK pole straps to the pole at the heights required to attach the Air4G.
2. Fasten the mounting brackets to the pole straps; position the tabbed strap lower on the pole with the tab facing down.
3. Lift the enclosure and place the screws through the head clearance holes and position the unit so that the top mounting holes retain the unit.



Caution: These units weigh 17 kg – 17.6 kg, take care when lifting.

4. Screw the bottom two the M8 screws and washers into the two standoff fittings at the bottom of the Air4G enclosure.
5. Attach Base Station and loosely tighten all screws.
6. Tighten all fixing screws.



Figure 11 – Pole Mounted Air4G

To mount the Air4G in the pole mount configuration (for poles 60 > 120 mm), perform the following steps:

1. Attach the two (2) pole brackets (shown above in Table 6) to the pole (with the threaded holes facing up) at the heights required to attach the Air4G.
2. Tighten upper pole bracket and hand tighten (loosely) the lower pole bracket for later adjustment.



Caution: These units weigh 17 kg – 17.6 kg, take care when lifting.

3. Lift and align the Air4G unit and place the screws through the head clearance holes and position the unit so that the top mounting holes retain the unit and loosely tighten all screws.
4. Tighten all fixing screws.

5.2 Wall mount configuration

The following image shows the wall mount assembly.

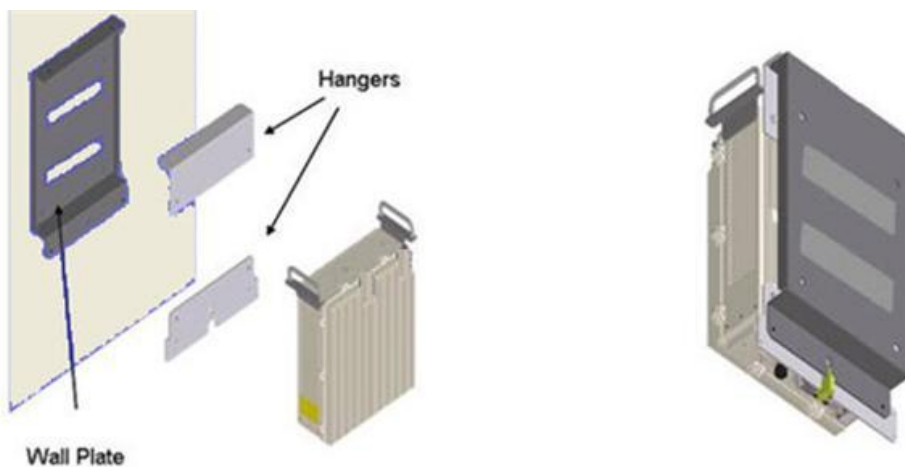

Figure 12 – Wall Mounted Air4G

The following diagram depicts the Wall Plate Details.

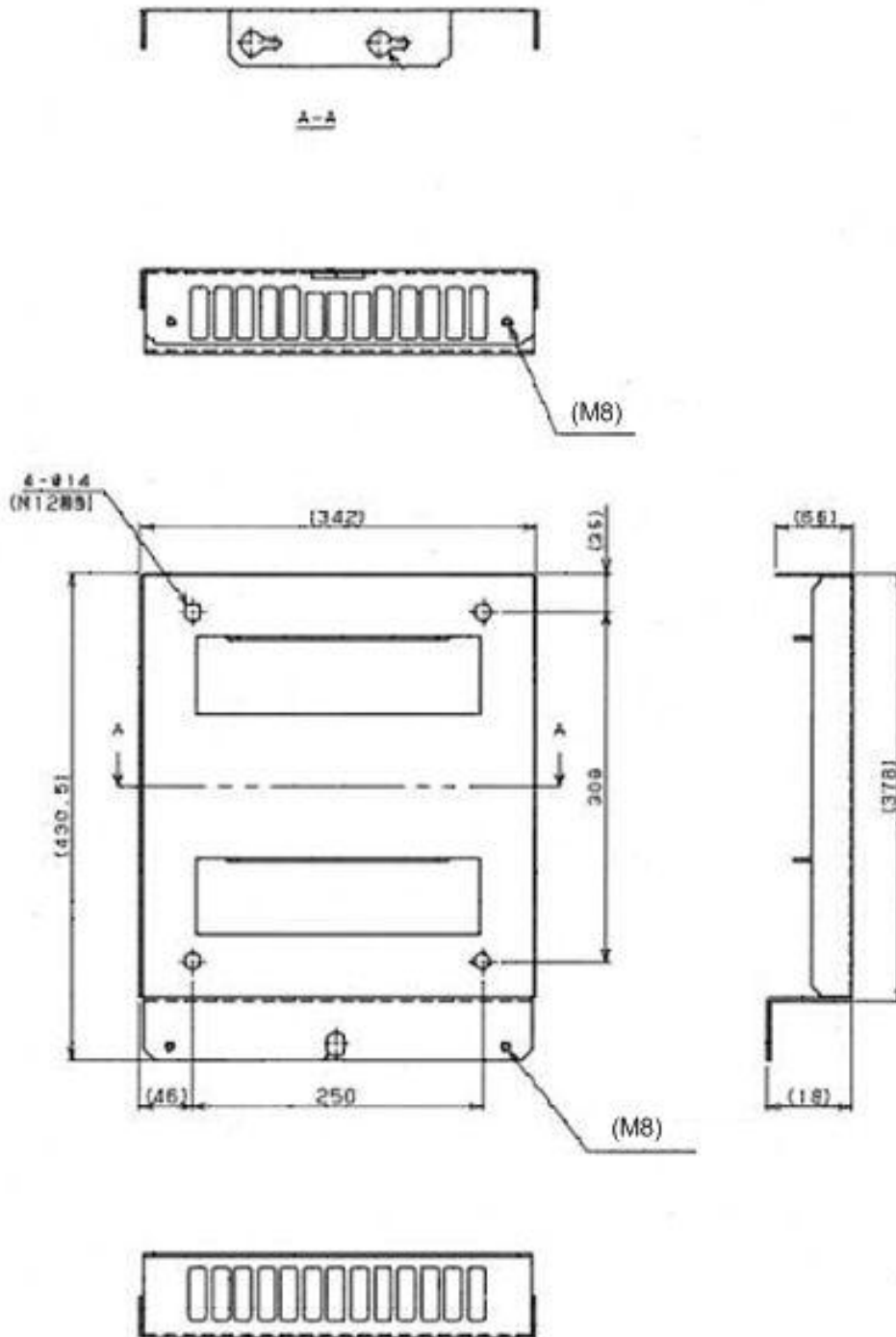

Figure 13 – Wall Mounted Air4G Wall Plate Details

To mount the Air4G in the wall mount configuration, perform the following steps:

1. Attach the Wall Plate to the wall at the height required to attach the Air4G.
2. Fasten the Hangars to the rear side of the Air4G enclosure, position the niched Hangar so it is lower on the wall with the niche facing down.
3. Lift the enclosure and place the screws through the head clearance holes and position the unit so that the top mounting holes retain the unit.



Caution: This unit weighs 17 kg – 17.6 kg, take care when lifting.

4. Screw the bottom two screws and washers into the two standoff fittings at the bottom of the Air4G enclosure.
5. Tighten all fixing screws.

5.2.1 Mounting Examples

The following displays a typical wall mount.

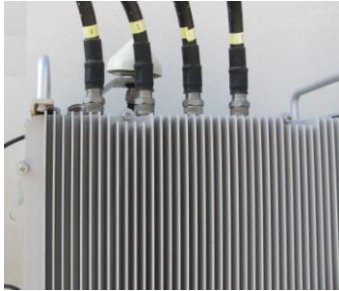

Figure 14 - Wall mount



Note: The GPS bracket (pre-assembled) is on the (back) side closest to the wall so as not to interfere with the sunshield assembly.

The following displays a possible assembly alternative in the event of interference to the GPS by equipment already in place.



Figure 15 - GPS alternative assembly

5.3 Air4G Connections

The following diagram displays the connections on the bottom side of the Air4G.

The base station requires a secure ground connection. The cable should also be grounded to the tower which is grounded at the tower base. A grounding screw fitted with a flat washer and lock washer is provided on the bottom of the chassis clearly marked with the universal ground symbol as shown below.

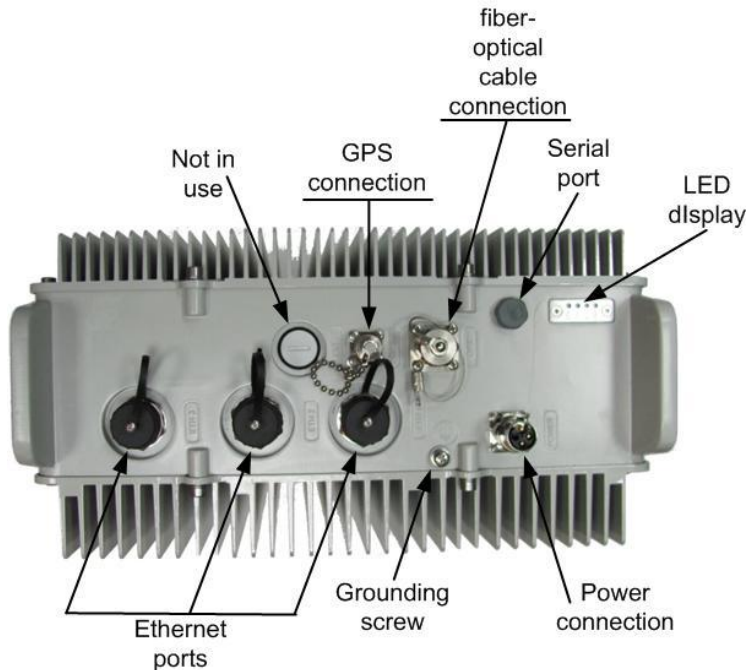

Figure 16 - Air4G connections (bottom)

5.4 Install Air4G Antennas

Use this procedure to install a linear dual slant antenna for the Air4G in the mast mount configuration.



Figure 17 – Air4G External Antenna Configuration



Note: Separate antenna distance according to RF planning.

5.4.1 Install Dual Slant Antenna



Figure 18 - Air4G Antenna Dual Slant Mast Mount Configuration

To mount the dual slant antenna for the Air4G in the mast mount configuration, perform the following steps:

1. Attach the Antenna brackets to the top and bottom of the radome.
2. Attach the tilt arm to the top bracket of the radome.
3. Fasten the ends of the adjustable pipe mounts to the top and bottom brackets of the radome.
4. Lift the radome and place the screws through the adjustable pipe mounts and position the radome so that the top mounting holes retain the unit.
5. Screw the bottom two screws and washers into the two standoff fittings at the bottom of the radome assembly.
6. Tighten all fixing screws.
7. Attach, connect and secure antenna RF cable between the antenna and the appropriate Air4G Antenna RF connection on the top of the unit.

5.4.2 Install Quad Slant Antenna



Figure 19 – Air4G Antenna Quad Slant Mast Mount Configuration

To mount the Quad slant antenna for the Air4G in the mast mount configuration, perform the following steps:

1. Attach the Antenna brackets to the top and bottom of the radome.
2. Attach to the top bracket of the radome.
3. Fasten the ends of the adjustable pipe mounts to the top and bottom brackets of the radome.
4. Lift the radome and place the screws through the adjustable pipe mounts and position the radome so that the top mounting holes retain the unit.
5. Screw the bottom two screws and washers into the two standoff fittings at the bottom of the radome assembly.
6. Tighten all fixing screws.
7. Attach, connect and secure antenna RF cable between the antenna and the appropriate Air4G Antenna RF connection on the top of the unit.

5.4.3 Antenna Mounting Clamps for Dual and Quad Slant Antennae

The following are some adjustable antenna mounting clamp options for both Dual and Quad Slant antenna scenarios.

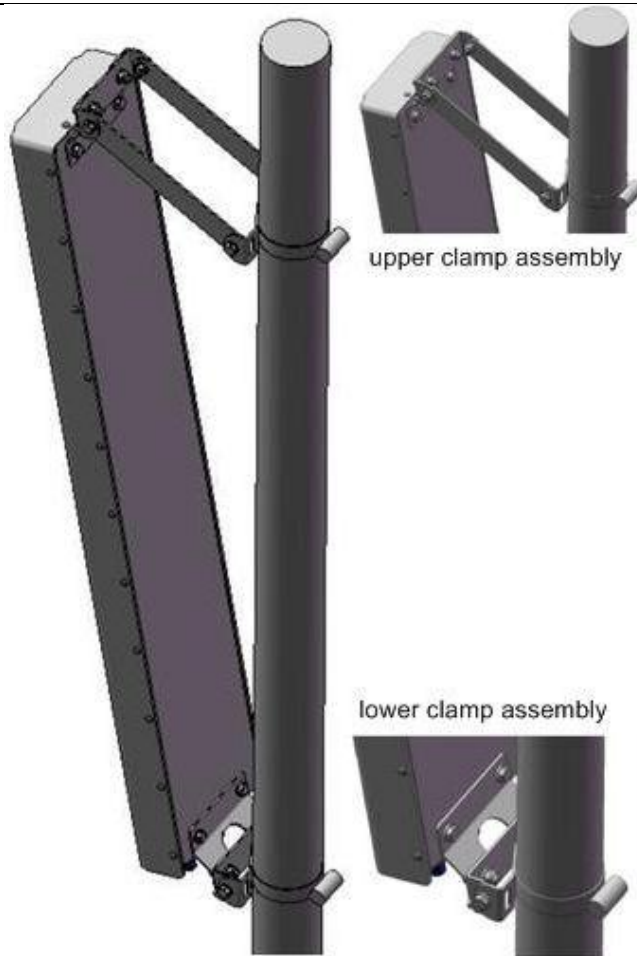

Figure 20 - Adjustable Mounting Kit, with Snaplock Stainless Steel Bands



Figure 21 - Adjustable Mounting Kit, with 'V' Blocks

5.5 Optional Mounting Antenna on Air4G

Either Antenna shown can be mounted on the Air4G unit or mast mounted.



Note: The sunshield kit is required for this type of assembly. Contact your supplier to order.

5.5.1 Variable Tilt Antenna

There is a Variable Tilt Antenna available for mounting on the Air4G. The antenna maybe connected directly to the Air4G with no need for physical tilting of the antenna. The Manual Electric Tilt (MET) antenna has a rotating nut that adjusts a threaded rod which moves in and out while displaying a tilt scale, as shown below.

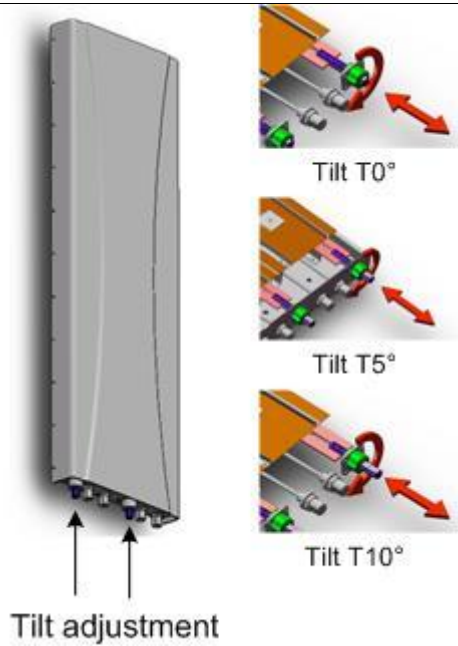

Figure 22 - Variable tilt antenna

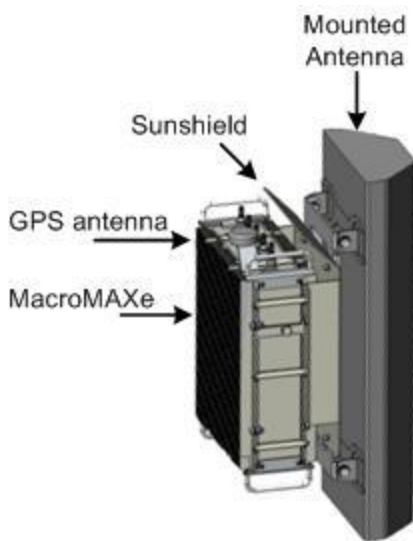

Figure 23 - Antenna mounted on Air4G

5.6 Antenna Connection



Caution: Antennas 1 & 2 Tx/Rx must be connected and attached before Air4G is powered on.



Caution: Power down Air4G prior to disconnecting antenna.

The following describes the antenna connection:



Note: Some antennas are labeled 1, 2, 3, 4 and some are labeled '+', '-', '+', '-'.



Caution: 1 & 2 Tx/Rx must be '+' & '-' or '-' & '+' and the same for 3 & 4.

Table 17 - Antenna connection

MacroMAXe port	Port Label	Antenna port
Tx/Rx	ANT 1	1 or '+'
Tx/Rx	ANT 2	2 or '-'
Rx	ANT 3	3 or '+'
Rx	ANT 4	4 or '-'

5.7 GPS Antenna Assembly

To mount the GPS antenna directly on the Air4G:

1. Route the RG58 cable through the flat washer and the 2 nuts (supplied).
2. Position the RG58 cable below the mounting hole on the GPS antenna mounting bracket, as shown below:

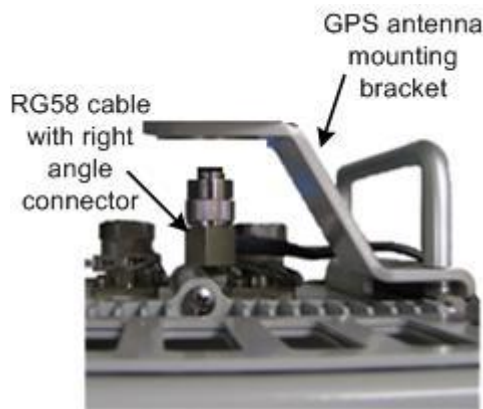

Figure 24 - GPS cable assembly prior to mounting

3. Hand-tighten the RG58 cable TNC (90°) connector to the mating connector on the GPS antenna.



Figure 25 - Attach GPS antenna to RG58 cable

4. Slide the flat washer up to the underside of the mounting bracket, then thread 1 nut onto the GPS antenna threaded base and tightened.

- The second nut is then secured and tightened against the first nut to create a clamp load against the first nut, as shown below:

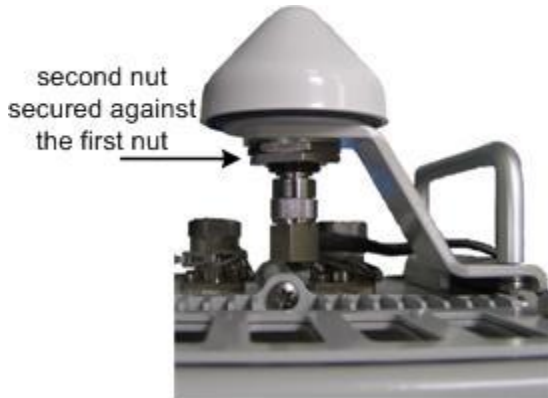

Figure 26 - GPS antenna assembled on bracket

5.8 Install Junction Box (Optional)



Note: Contact Airspan customer-service to determine whether junction box installation is required. Installation may be required, depending on the distance between the external power-supply and the BS, as well as the minimum voltage supplied by the power-supply.

The Junction box (optional) can be pole-mounted or wall-mounted.



Warning: Mount the junction box in an orientation such that the cable ports (located on the bottom) face downwards. This prevents rain water from settling on the ports, and thereby, avoiding damage.

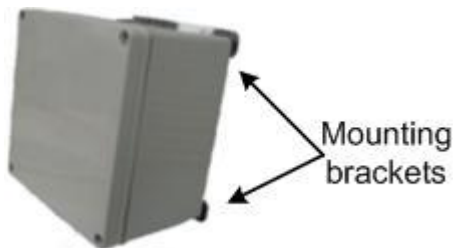

Figure 27 - Junction box with mounting brackets assembled

For either mounting method, the mounting bracket provides mounting holes (displayed below):

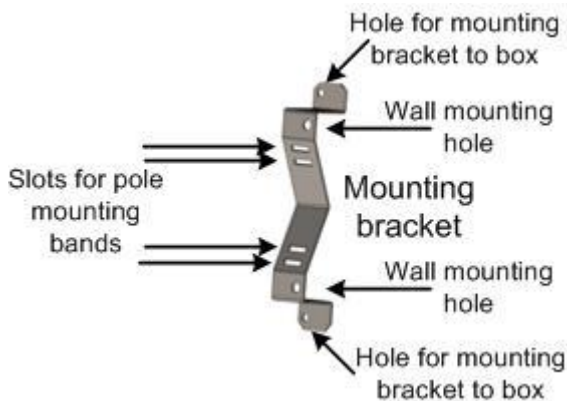

Figure 28 - mounting bracket (2 required)

5.8.1 Junction Box Installation

To install the junction box:

1. Prior to installation connect the 2 mounting brackets to the back of the junction box fastening to the provided holes. The wall mounting hole orientation should be towards the outer edges of the junction box.
2. Remove the junction box's cover, leaving the rubber gasket in place.
3. Prepare the cables for connection by performing the following:
 - a. Strip about 25.4 mm (1 inch) of the outer jacket of the cable to expose the wires.
 - b. Using a wire-stripping tool, expose about 6.3 mm (0.25 inch) of each of the wires by stripping the wires' insulation.
4. Determine which cable entry holes are to be used and remove the appropriate plug.

Table 18 - Cable hole sizes

Cable Entry hole determination
Gland hole PG11 (M18) for cable terminating at MicroMAXe
Gland hole PG29 (M36) for cable 12AWG x6
Gland hole PG16 (M22) for cable 14AWG x2



Note: Save the rubber grommets from the plugs to be used on the weatherproof glands (connectors).

5. Remove the nut on the weatherproof connector and slide the rubber grommet onto the threaded shaft.
6. Set the weatherproof connector into the hole and from inside the box, thread the included nut onto the shaft until tight.
7. Insert the exposed wires into the relevant screw-type terminal block (+ to + and – to –) and then secure them in place by tightening the screw of each terminal.
8. Fasten the Junction box onto the pole or wall as required within the required distance of the Air4G enclosure.
9. Perform the same procedure (steps 3-7) with the cable terminating in the in the Air4G enclosure.
10. Open the connector clamp collar and feed about 101.6 mm (4 inches) of cable from the Air4G through it and into the box. Tighten the collar around the cable, forcing the seal to compress around the cable.
11. Replace the cover by using the four (4) screws, ensuring the gasket (for weatherproofing) is firmly in place on the rim of the cover.



Note: It is important to provide strain relief and drip loop for the cables. Create a drip loop and strain relief using cable tie, to tie cable to pole, as displayed in the figure below:



Figure 29 - Air4G assembly with optional junction box

6 Connect and Manage Cables

The Ethernet cable is connected to the Air4G using a standard RJ45 connector protected by a harsh environment protective casing.

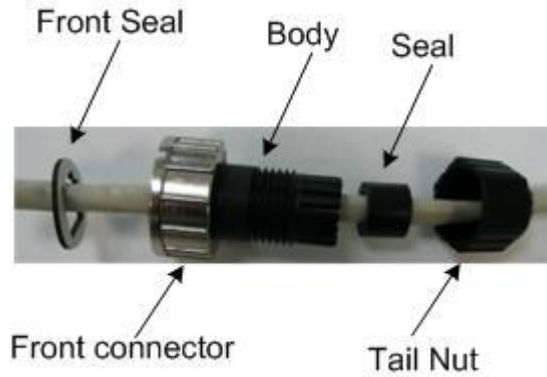

Figure 30 – Ethernet connector cable termination

6.1 Assemble Ethernet Connector

1. Pass the Cat 5 cable through the seal, front connector, body and tail nut of the environmental connector casing as shown above.
2. Paste the front seal on the collar of the connector body.
3. Terminate the Ethernet cable with an RJ45 connector plug.
4. Seat the RJ45 connector plug securely into the body cavity.
5. Tighten the tail nut on to the body forcing the seal to compress around the cable.



Figure 31 – Ethernet environmental connector assembly

7 Set Power System



Hazardous voltage! Before working, ensure that the power is removed from the power connection cables. When the system is powered on, **do not touch the power terminals.**

7.1 Power Input - DC

Each unit is provided with a 3/10/30 meter 48 volt power cable terminated with a female connector at one end and bare wires at the other.



Caution: It is important that the power connector is attached at the correct end or damage to the connector/equipment will result.



Note: Check Power Supply for proper polarization.

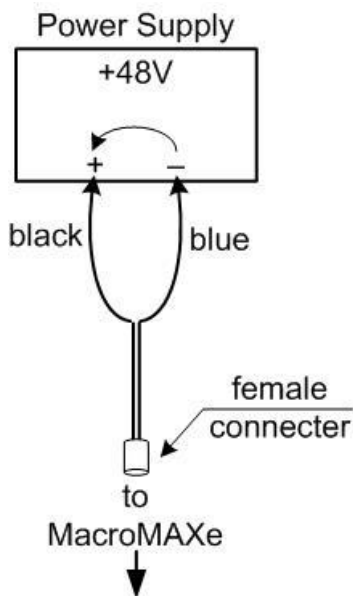

Figure 32 – DC Power connection

8 Appendix A

8.1 Review Job Sheet

The *Job Sheet* should include the following information:

- **BS location and identity.**
- Whether the system is required to be locked to a GPS timing reference.
- **A BSID is required for each BS TRx.** This should be in a format xxxxxx:xxxxxx where x is a decimal digit.
- Network configuration information for the BS TRx.
- **Traffic Port:** Not applicable.
- **IP Address:** Should only be set if Management IP Mode is set to Static IP Address. See below for Management IP Mode parameter.
- **Netmask:** Should only be set if Management IP Mode is set to Static IP Address. See below for Management IP Mode parameter.
- **Default Gateway:** Should only be set if Management IP Mode is set to Static IP Address. See below for Management IP Mode parameter.
- **Management VLAN:** Specified as either Untagged or Tagged
- **Management VLAN Tag:** Should only be set if Management VLAN is set to Tagged
- **Management IP Mode:** Specified as Static IP Address or Obtain IP Address via DHCP
- **Ethernet Mode:** Specified as Auto-negotiate or Fixed
- **Ethernet Rate:** Need only be configured if Ethernet Mode is set to Fixed, specified as 10M or 100M.
- **Ethernet Duplex:** Need only be configured if Ethernet Mode is set to Fixed, specified as Full or Half.
 - **SNMP configuration information.** This will allow events from the BS to arrive at the specified Netspan server. This will include the following information:
 - **Read Only Community:** This should be specified to the same value as in Netspan Discovery Parameters (found under Server on Netspan left hand panel).
 - **Read Write Community:** This should be specified to the same value as in Netspan Discovery Parameters (found under "Server" on Netspan left hand panel).
 - **SNMP Port Number:** This should be specified to the same value as in Netspan Discovery Parameters (found under "Server" on Netspan left hand panel).
 - **IP Address:** This specifies Netspan IP address (found under Server Global Configuration, which is under Server on Netspan left hand panel).
 - **Community:** Normally specified to the same value as for Read Only Community.
 - **Port Number:** Normally specified to a value of 9023.
 - **NTP configuration.** This specifies a list of NTP servers.

8.2 Securing Fiber-optic Cable

The Milli-Tie can be used to secure cables in the same manner as normally used for nylon straps. The steps below show the basic use of the product.



Caution: Over-tightening of cable ties may causes damage and degrade system performance.

To secure fiber-optic cables, perform the following steps:

1. Place the Millie-Tie around the target, and thread the tongue through the last large aperture in the rearmost cell.
-



Figure 33 - Secure fiber-optic cable, place tie

2. Pull or slide the Millie-Tie onto the target. Note that the Millie Tie stretches to cushion the installation.



Figure 34 – Secure fiber-optic cable, pull tie

3. Release the tension when snug, then cut and remove any excess strip. Always cut through the square sections, not the wider cells.



Figure 35 – Secure fiber-optic cable, snug tie



Note: Millie-Tie is efficient, and simply gets a little shorter after each use. The remaining strip can be kept and reused.



Figure 36 – Secure fiber-optic cable, cut excess tie

6. Repeat these steps for each use.



Figure 37 – Secure fiber-optic cable, use excess tie



Figure 38 – Secure fiber-optic cable, re-use excess tie

8.3 Connecting the Fiber-optic Cable

To secure fiber-optic cable to the Air4G, perform the following steps:

1. Remove the dust cover from end of a panel connector:

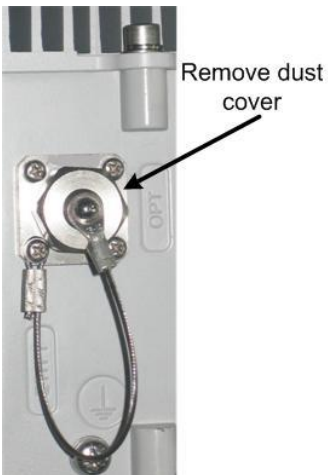

Figure 39 - fiber-optic connector with dust cover



Figure 40 – dust cover removed

7. Remove the protective cover from the fiber-optical cable.
8. Align the fiber-optical cable connector and line up the groove on the cable connector with the pin on the panel connector.
9. Screw the connector cover nut until hand-tight.



Figure 41 - Fiber-Optic Outdoor Connector Plug (multimode)



Figure 42 - screw hand-tight



Figure 43 - Fiber-optic cable connected

9 Appendix C – Glossary of Terms

AAA	Authentication, Authorization and Accounting
AAS	Advanced Antenna System
AF	Application Function
ARQ	Automatic Repeat reQuest
ASN	Access Service Network
ASN GW	ASN Gateway
ATCA	Advanced Telecommunications Computing Architecture
BS	Base Station
BWA	Broadband Wireless Access
CHAP	Challenge Handshake Authentication Protocol
CPE	Customer Premises Equipment
CQI	Channel Quality Indicator
CSN	Connectivity Service Network
DSM	Digital Surface Model
DTM	Digital Terrain Model
EAP	Extensible Authentication Protocol
FA	Foreign Agent
FBSS	Fast Base Station Switching
GUI	Graphical User Interface
HA	Home Agent
H-ARQ	Hybrid Automatic Repeat reQuest
HO	Handover/Handoff
IMS	IP Multimedia Subsystem
IP	Internet Protocol
IPsec	IP security
LR	Location Register
MAC	Media Access Control
MDH	Macro Diversity Handover
MIMO	Multiple Input Multiple Output
MIP	Mobile IP
MRC	Maximal Ratio Combining
MS	Mobile Station
NAP	Network Access Provider
NAS	Network Access Server
NLOS	Non Line of Sight
NSP	Network Service Provider
NWG	Network Working Group



Air4G Installation Guide



OBSAI	Open Base Station Standard Initiative
OFDMA	Orthogonal Frequency Division Multiplexing (Multiple Access)
PA	Paging Agent
PAAA	Proxy AAA
PC	Paging Controller
PF	Policy Function
PHY	PHYSical Layer
PMIP	Proxy MIP
PPP	Point-to-Point Protocol
RADIUS	Remote Authentication Dial In User Service
RRA	Radio Resource Agent
RRC	Radio Resource Controller
RRM	Radio Resource Management
SAS	Smart Antenna System
SDR	Software Defined Radio
SFA	Service Flow Authorization
SFM	Service Flow Management
SIM	Subscriber Identity Module
SIP	Session Initiation Protocol
SOFDMA	Scalable Orthogonal Frequency Division Multiplexing (Multiple Access)
STC	Space Time Coding
TDD	Time Division Duplex
VoIP	Voice over IP
X.509	ITU-T standard for PKI digital certificates

10 Appendix D – Installation Checklist

The Checklist below gives the high-level steps in the Workflow for this procedure. Detach or print this page to use as a job-aid for completing the actions this procedure requires.

Table 19 - Checklist for Procedure

Procedure	Actions	Outcome
1. Verify Prerequisites	Verify safety requirements Verify installation requirements	All requirements are in place for a successful commissioning of Air4G.
2. Install Air4G	Pole mount configuration Wall mount configuration Install Air4G antennas	
3. Connect and manage cables	Assemble Ethernet connector <i>or</i> Disassemble Ethernet connector, <i>then</i> Assemble LTW Ethernet connector	
4. Set power system	Power input Power output	

11 Appendix E

11.1 Revision History

Revision	Originator	Date	Description
Draft 1	D. Cann	2-2009	Initial document
Draft B	M. Falik	3-2009	Additional content & template changes
Rev A	M. Falik	10-2009	Additional content
Rev B	M. Falik	10-2009	Corrected Graphics + Additional content
Rev C	M. Falik	12-2009	Added Junction box data
Rev D	M. Falik	12-2009	Additional content
Rev E	M. Falik	03-2010	Frequency ranges and latest support
Rev E1	M. Falik	05-2010	Added antenna connection
Rev E2 + 3	M. Falik	06-2010	Antenna connection table correction
Rev F, F1, F3 & F4	M. Falik	08-2010	Added 2x10-4, 0707 variants - PS cable lengths – MAX output
Rev G	M. Falik	11-2010	Product name change + additional content

11.2 Contact Information

Customer Service Help-Desk for customer service emergency

Airspan Networks have introduced the Airspan Tracker application to enable prompt and efficient Customer Support services.

If you do not have an Airspan Tracker account, please obtain login credentials by filling-in the form in the main page www.airspan.com/Support Register New Account

Worldwide Headquarters:

Airspan Networks Inc.
777, Yamato Road, Suite 310,
Boca Raton, FL 33431, USA
Tel: +1 561 893 8670

www.airspan.com

Feedback:

To provide feedback on this document, please send comments to the following email address: documentfeedback@airspan.com