



IP-based
Broadband Wireless Access (BWA) System

605-0000-742 Rev D

MicromAX-SOC

Hardware Installation

Table Of Contents

Introduction	1
Purpose	1
Targeted Audience	1
Referenced Documentation	1
Conventions	1
Warnings and Cautions	2
Human Exposure to Radio Frequencies	2
Radio Interference	2
Avoiding Radio Interference.....	2
Modifications	2
General	2
Manufacturer's Disclaimer Statement	2
DECLARATION OF CONFORMITY.....	4
European Community, Switzerland, Norway, Iceland, and Liechtenstein	4
Declaration of Conformity with Regard to the R&TTE Directive 1999/5/EC.....	4
System Overview.....	6
MicroMAX-SOC Frequency Ranges	7
Main Features.....	7
Customer Benefits.....	7
Architecture	8
Power.....	8
Models	8
Installation Prerequisites.....	9
Package Contents.....	9
Required Tools.....	9
Radio Site Planning	9
Radio Antenna Alignment	10
Physical Description	11
MicroMAX-SOC BSR	11
Physical Dimensions.....	11
Ports	12
SDA-4S Type II	13
Physical Dimensions.....	13
Ports	14
LEDs	15
Mounting the Base Station Radio (BSR).....	16
Mounting the MicroMAX-SOC.....	16
Pole-Mounting the BSR	16

Wall-Mounting the BSR (Optional) 21

Installing the SDA-4S Type II 24

 Wall Mounting..... 24

Cabling the BSR..... 26

 Connecting the BSR to the SDA-4S 26

 SDA-4S Type II 27

 Using the SDA-4S Type II..... 27

Connecting the sda-4s to the power supply..... 28

 Connecting the SDA-4S Type II..... 28

 Connecting SDA-4S to Ethernet Network 29

 Connecting Lightning and Surge Protector..... 29

Connecting an External Antenna 33

 Connecting Third Party External Antenna 33

Trademarks and Copyrights..... 35

Contact Information 36

Revisions..... 37

Warnings..... 38

 1. Disclaimer 38

 1.1 Safety Warnings 38

 1.2 Important Warning Symbols..... 38

 1.3 Important Service Information..... 39

 1.4 UL Information..... 39

 1.5 CE Notice 39

 1.6 European Community, Switzerland, Norway, Iceland, and Liechtenstein..... 40

 Declaration of Conformity with Regard to the R&TTE Directive 1999/5/EC..... 40

 1.7 CAUTION..... 41

 1.8 Lightning Protection 41

Glossary 43

INTRODUCTION

Thank you for purchasing Airspan's MicroMAX-SOC Base Station Radio. The MicroMAX-SOC Base Station Radio (BSR) is part of Airspan's AS.MAX family of WiMAX-based products.

This section discusses the purpose, audience, conventions, and customer support of this guide.

Purpose

This guide provides step-by-step instructions for setting up and installing the MicroMAX-SOC BSR.

Targeted Audience

This guide is intended for the Airspan technician who is a qualified installer responsible for installing the MicroMAX-SOC BSR.



Referenced Documentation

For a description of the Web-based management tools for configuring and managing MicroMAX-SOC BSR, see the following manuals:

-  MicroMAX-SOC Web-based Management User's Guide

Conventions

This guide uses the following typographical conventions:

Convention	Meaning	Example
Bold	Command, icon, button, and field	Click the Next button.
"To" in bold face and at the beginning of a sentence	Introduces a numbered procedure	To download a SW file: 1. ...
	Note that provides useful information	--
	Warning that provides information that can prevent and avoid bodily or mechanical harm	--

WARNINGS AND CAUTIONS

Human Exposure to Radio Frequencies

The MicroMAX-SOC should be installed and operated from a minimum distance of 20 cm to your body.

Radio Interference

This equipment generates, uses, and can radiate radio frequency energy and, if not installed and used in accordance with the instructions, may cause harmful interference to radio communications. However, there is no guarantee that interference will not occur in a particular installation. If this equipment does cause harmful interference to radio or television reception, which can be determined by turning the equipment on and off, the user is encouraged to try to correct the interference by performing one or more of the following measures:

- ▶ Reorientate or relocate the receiving antenna
- ▶ Increase separation between the equipment and receiver
- ▶ Connect the equipment to an outlet on a circuit different from that to which the receiver is connected
- ▶ Consult the dealer or an experienced radio/TV technician for help

Avoiding Radio Interference

- ▶ This transmitter must not be co-located or operating in conjunction with any antenna or transmitter.
- ▶ Ensure a minimum of 1-meter separation between co-located BSRs.

Modifications

Any changes and modifications to this device that are not expressly approved by Airspan Networks may void the user's authority to operate the equipment.

General

- ▶ Only qualified personnel should be allowed to install, replace, and service the equipment.
- ▶ The device cannot be sold retail, to the general public or by mail order. It must be sold to dealers.
- ▶ Installation must be controlled.
- ▶ Installation must be performed by licensed professionals.
- ▶ Installation requires special training.
- ▶ The MicroMAX-SOC radio and antenna should be installed ONLY by experienced installation professionals who are familiar with local building and safety codes and, wherever applicable, are licensed by the appropriate government regulatory authorities. Failure to do so may void Airspan's AS.MAX product warranty and may expose the end user or the service provider to legal and financial liabilities. Airspan and its resellers or distributors are not liable for injury, damage or violation of regulations associated with the installation of outdoor units or antennas.

Manufacturer's Disclaimer Statement

The information in this document is subject to change without notice and does not represent a commitment on the part of the vendor. No warranty or representation, either expressed or implied, is made with respect to the quality, accuracy or fitness for any particular purpose of this document. The manufacturer reserves the right to make changes to the content of this document and/or the products associated with it at any time without obligation to notify any person or organization of such changes. In no event will the manufacturer be liable for direct,

indirect, special, incidental or consequential damages arising out of the use or inability to use this product or documentation, even if advised of the possibility of such damages. This document contains materials protected by copyright. All rights are reserved. No part of this manual may be reproduced or transmitted in any form, by any means or for any purpose without expressed written consent of its authors. Product names appearing in this document are mentioned for identification purposes only. All trademarks, product names or brand names appearing in this document are registered property of their respective owners.

DECLARATION OF CONFORMITY

European Community, Switzerland, Norway, Iceland, and Liechtenstein

Declaration of Conformity with Regard to the R&TTE Directive 1999/5/EC

English:

This equipment is in compliance with the essential requirements and other relevant provisions of Directive 1999/5/EC.

Deutsch:

Dieses Gerät entspricht den grundlegenden Anforderungen und den weiteren entsprechenden Vorgaben der Richtlinie 1999/5/EU.

Dansk:

Denne udstyr er i overensstemmelse med de væsentlige krav og andre relevante bestemmelser i Direktiv 1999/5/EF.

Español:

Este equipo cumple con los requisitos esenciales así como con otras disposiciones de la Directiva 1999/5/EC.

Greek:

ΜΕ ΤΗΝ ΠΑΡΟΥΣΑ Airspan ΔΗΛΩΝΕΙ ΟΤΙ Ο ΕΞΟΠΛΙΣΜΟΣ ΣΥΜΜΟΡΦΩΝΕΤΑΙ ΠΡΟΣ ΤΙΣ ΟΥΣΙΩΔΕΙΣ ΑΠΑΙΤΗΣΕΙΣ ΚΑΙ ΤΙΣ ΛΟΙΠΕΣ ΣΧΕΤΙΚΕΣ ΔΙΑΤΑΞΕΙΣ ΤΗΣ ΟΔΗΓΙΑΣ 1999/5/ΕΚ.

Français:

Cet appareil est conforme aux exigences essentielles et aux autres dispositions pertinentes de la Directive 1999/5/EC.

Íslenska:

Þessi búnaður samrýmist lögboðnum kröfum og öðrum ákvæðum tilskipunar 1999/5/ESB.

Italiano:

Questo apparato é conforme ai requisiti essenziali ed agli altri principi sanciti dalla Direttiva 1999/5/EC.

Nederlands:

Deze apparatuur voldoet aan de belangrijkste eisen en andere voorzieningen van richtlijn 1999/5/EC.

Norsk:

Denne utstyret er i samsvar med de grunnleggende krav og andre relevante bestemmelser i EU-direktiv 1999/5/EC.

Português:

Este equipamento satisfaz os requisitos essenciais e outras provisões da Directiva 1999/5/EC.

Suomalainen:

Tämä laite täyttää direktiivin 1999/5/EY oleelliset vaatimukset ja on siinä asetettujen muidenkin ehtojen mukainen.

Svenska:

Denna utrustning är i överensstämmelse med de väsentliga kraven och andra relevanta bestämmelser i Direktiv 1999/5/EC.

The Declaration of Conformity related to this product can be obtained from product_management@Airspan.com

SYSTEM OVERVIEW

MicroMAX-SOC is a highly upgradeable Micro-cell base station, based on the Sequans System On a Chip, with a pole/roof (wall) mounted radio system and antennae. This high performance chip can support up to 28 + 28 MHz channels (full duplex) forms part of the AS.MAX portfolio of WiMAX network infrastructure equipment. It is compatible with the Airspan EasyST and ProST subscriber terminals and other manufacturer's CPEs that are fully WiMAX compliant.

The MicroMAX-SOC BSR is an outdoor radio that is mounted outside on a pole or wall. The BSR provides a wireless link with subscribers and interfaces with the provider's backbone. The MicroMAX-SOC BSR is available in two models. These models differ by antenna design (providing integral flat-panel antennas, or an N-type port for attaching third-party external antennas). MicroMAX-SOC BSR is available in numerous ETSI frequency bands, operating in FDD and TDD modes in numerous channels, see: MicroMAX-SOC Frequency Ranges.

The BSR connects to the indoor Ethernet hub/switch by a CAT 5e cable, which carries the Ethernet signal, and DC power. For a MicroMAX-SOC Base Station consisting of multiple BSRs, the BSRs connect to individual Subscriber Data Adapters (SDA-4S). For a Base Station consisting of a single BSR, the BSR typically connects to a single Subscriber Data Adapter (SDA-4S).

MicroMAX-SOC BSR provides a low cost, high-performance point-to multipoint packet-based Broadband Wireless Access (BWA) solution. MicroMAX-SOC BSR Provides wireless connectivity designed to deliver high-speed data, voice over IP (VoIP) and multimedia services to residential, SOHO (Small Office/Home Office), and SME (Small to Medium Enterprises).

The MicroMAX-SOC is an encased outdoor radio providing access to the MicroMAX-SOC's communication ports on its bottom panel. The MicroMAX-SOC's back panel provides holes for mounting.

MicroMAX-SOC BSR interfaces with the subscriber's LAN through the SDA-4S Type II (referred henceforth as SDA-4S) integrated LAN switches.

- SDA-4S Type II: integrated LAN switch, providing power and four 10/100BaseT ports for interfacing with the subscriber's network

MicroMAX-SOC can be managed by an SNMP-based network management system (Netspan) using standard and proprietary MIBs. In addition, external third-party management systems such as HP OpenView can also manage the MicroMAX-SOC using these MIBs. Basic management can be performed using any standard Web browser.

MicroMAX-SOC Frequency Ranges

The table below lists the frequency range of MicroMAX-SOC models currently available. This table will grow as more models become available.

Frequency Band	Channel Bandwidth	Channel Throughput
3.3 – 3.5 GHz in TDD mode	<ul style="list-style-type: none"> ▶ 1.75 MHz ▶ 3.5 MHz ▶ 5 MHz 	<ul style="list-style-type: none"> ▶ speeds of up to 6.5 Mbps ▶ speeds of up to 13.1 Mbps ▶ speeds of up to 18 Mbps
3.4 – 3.6 GHz in FDD mode	<ul style="list-style-type: none"> ▶ 1.75 MHz ▶ 3.5 MHz 	<ul style="list-style-type: none"> ▶ speeds of up to 6.5 Mbps ▶ speeds up to 13.1 Mbps
4.9 – 5.0 GHz in TDD mode	<ul style="list-style-type: none"> ▶ 5 MHz ▶ 10 MHz 	<ul style="list-style-type: none"> ▶ speeds of up to 18 Mbps ▶ speeds of up to 37 Mbps
5.725 – 5.825 in TDD mode	<ul style="list-style-type: none"> ▶ 5 MHz ▶ 10 MHz 	<ul style="list-style-type: none"> ▶ speeds of up to 18 Mbps ▶ speeds of up to 37 Mbps

Main Features

- ▶ Outdoor Unit(s):
 - MicroMAX-SOC Base Station Radio(s) (BSR)
- ▶ Indoor:
 - SDA-4S Type II: small low cost IDU with built in LAN switch
- ▶ IDU/ODU connectivity:
 - BSR requires CAT 5e cable 24 gauge or better (22 gauge recommended)
 - Fast Ethernet: 4 pins
 - (-48) VDC power: BSR FDD/TDD requires 2 pins
 - IDU/ODU length for BSR FDD: up to 100 meters
- ▶ Minimum configuration:
 - SDA-4S and a single BSR
- ▶ Larger configurations:
 - N*SDA-4Ss and N*BSRs

Customer Benefits

The MicroMAX-SOC BSR offers the following customer benefits:

- ▶ Based on the latest wireless technology WiMAX IEEE 802.16 2004 standard
- ▶ SOC engine for best cost/performance
- Based on Sequans "System On a Chip" (SOC)
 - high performance chip
 - high growth potential

Architecture

The MicroMAX-SOC system consists of the following component designs:

- ▶ Integrated Antenna Design
 - ▶ Encased MicroMAX-SOC BSR outdoor unit with integrated antenna
 - ▶ SDA-4S Type II indoor unit
- ▶ External Antenna Design
 - ▶ Encased MicroMAX-SOC BSR outdoor unit
 - ▶ SDA-4S Type II indoor unit
 - ▶ Third-party external antenna (optional deployment)

The figure below displays a typical setup of the MicroMAX-SOC(s) mounted outdoors on a pole (with an integrated antenna).

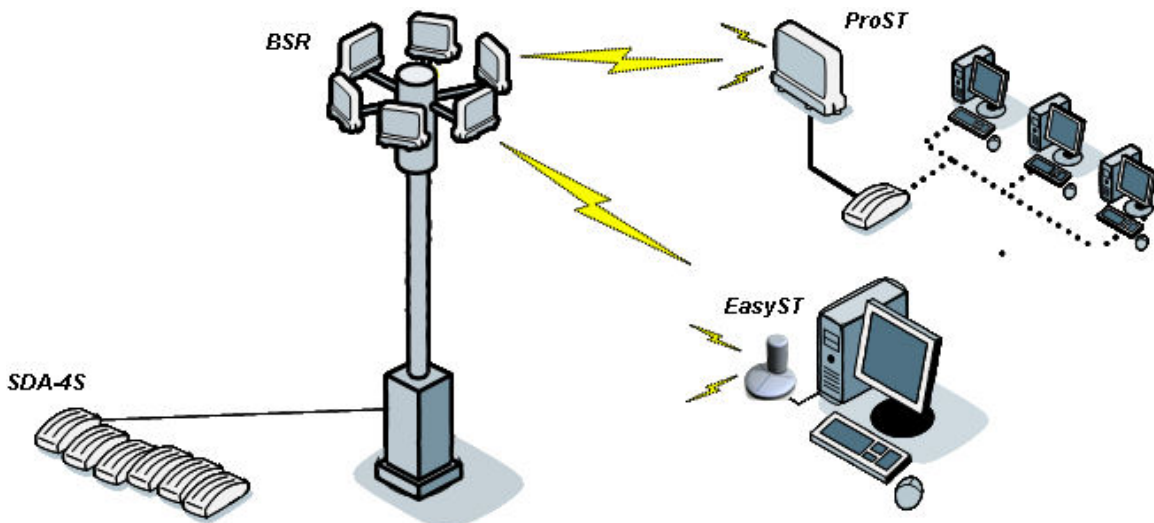

Power

The SDA-4S is a switch providing the MicroMAX-SOC BSR with -48 VDC power supply, and 10/100BaseT interface with the subscriber's PCs/network.

Models

The MicroMAX-SOC is available in the following basic physical designs:

- ▶ MicroMAX-SOC with a built-in (integral), internal antenna
- ▶ MicroMAX-SOC with an N-type type RF connector for connecting an optional third-party external antenna

 **Note:** A MicroMAX-SOC with an N-type port for attaching a third-party external antenna does not provide a built-in antenna.

INSTALLATION PREREQUISITES

Before installing your MicroMAX-SOC, review:

- ▶ Package contents
- ▶ Required tools
- ▶ Radio Site planning

Package Contents

Examine the AS.MAX shipping container. If you notice any damage, or missing items as listed in the Packing List, immediately notify the carrier that delivered the unit and contact a Airspan representative.

The MicroMAX-SOC kit should contain the following items:

- ▶ MicroMAX-SOC Base Station radio
- ▶ DB15-to-RJ45 adapter for plugging into the BSR's 15-pin D-type port
- ▶ Pole-mounting kit:
 - 2 x M10 hex head screws
 - 2 x M10 flat washers
 - 2 x M10 spring lock washers
 - 2 x M10 hex nuts
- Mounting bracket
 - 2 x M6 hex head screws
 - 2 x M6 spring lock washers
- Clamping bracket
 - 2 x M8 'U'- bolts
 - 4 x M8 hex nuts
 - 4 x M8 plain washers
 - 4 x M8 spring lock washers



Note: The standard MicroMAX-SOC kit does not include wall-mounting accessories. For pricing and ordering of wall-mounting accessories, please contact your nearest Airspan dealer.

Required Tools

The following tools are required to install the MicroMAX-SOC unit:

- ▶ Torque wrench for N-type connectors (only relevant when implementing external antenna)
- ▶ Cable stripping tool
- ▶ 10-, 13-, and 17-mm A/F open ended spanners

Radio Site Planning

Proper site selection and planning before installing your MicroMAX-SOC will ensure a successful deployment of your AS.MAX system. A summary of the main site planning considerations is provided below:

- ▶ Minimum obstructions (e.g. buildings) in the radio path between base station and the subscriber terminals
- ▶ Mount radio as high as possible to avoid obstructions in the wireless path

- ▶ Check possibility of future obstructions such as plans to erect buildings and trees that may grow tall enough to obstruct the wireless path
- ▶ Align radio for maximizing received signal strength (RSS)
- ▶ Consider nearby sources of interference that could degrade performance of radio
- ▶ Mount radio as far from sources of interference as possible
- ▶ Ensure base station and subscriber terminals (i.e ProST/EasyST) are within maximum coverage range of reception
- ▶ Maximum standard CAT-5e cable length connecting the MicroMAX-SOC to the indoor SDA-4S is 100 meters
- ▶ Ensure that you have sufficient wiring conduit and cable ties to channel and protect the CAT 5e cable connecting the outdoor MicroMAX-SOC to the indoor SDA-4S

Radio Antenna Alignment

ProST

Once the subscriber unit (i.e. ProST) is installed and aimed in the general direction of the BSR, it is recommended to measure the received signal strength (RSS) to determine the signal strength received from the BSR, and to precisely align the ProST for maximum signal strength.

You need to orientate (up/down, left/right) the ProST until the maximum RSSI levels are achieved, and then secure the ProST.

EasyST

Once the subscriber unit (i.e. EasyST) is installed and aimed in the general direction of the BSR, simply move the EasyST to the position that gives optimal reception.

PHYSICAL DESCRIPTION

This section provides a description of the components of the MicroMAX-SOC installation:

- ▣ MicroMAX-SOC (outdoor unit)
- ▣ SDA-4S Type II (indoor unit)

MicroMAX-SOC BSR

The BSR is an encased outdoor radio providing access to communication ports on its bottom panel. The BSR's back panel provides holes for mounting.

Physical Dimensions

The table below lists the physical dimensions of the BSR.

Parameter	Value	Comment
Height	400 mm (15.74 inches)	The physical dimensions exclude the mounting kit.
Width	317 mm (12.48 inches)	
Depth	65.5 mm (2.58 inches)	
Weight	3.8 kg	

The figure below illustrates the MicroMAX-SOC's physical dimensions.

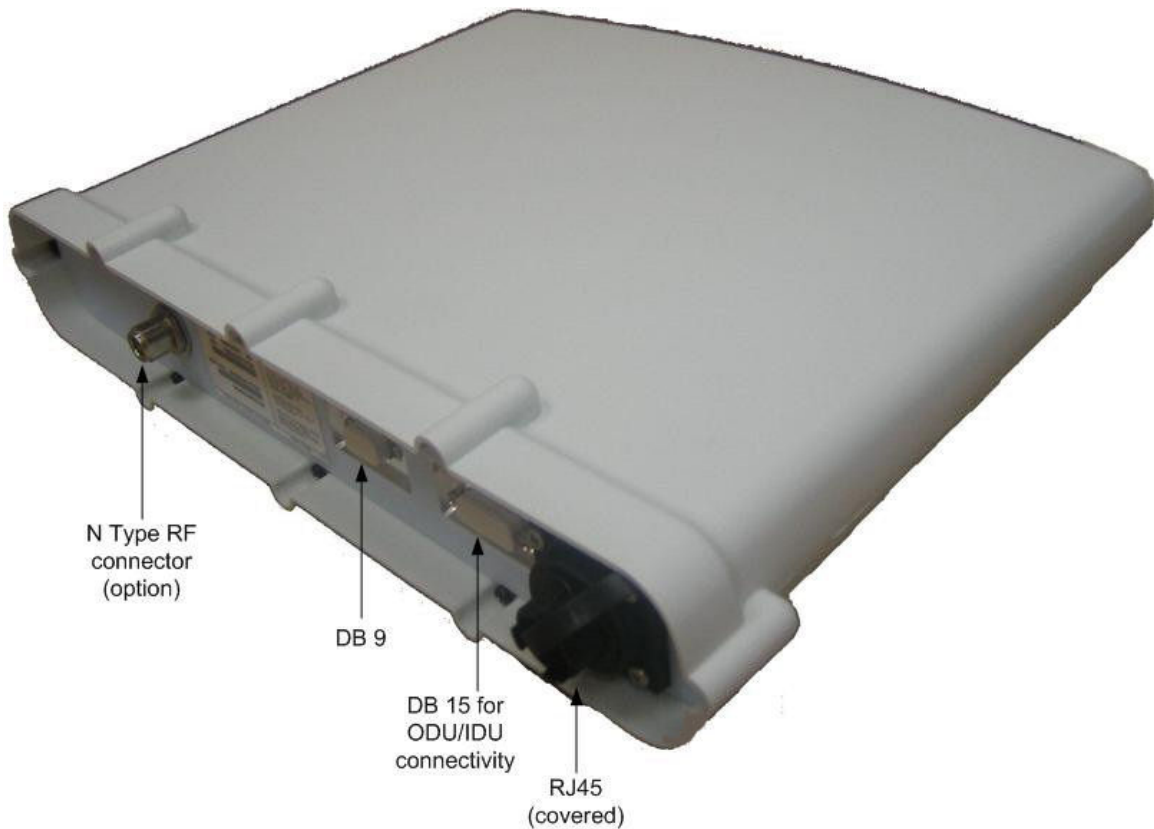

 **Note:** BSR models that use third-party external antennas provide an N-type receptacle for attaching an external antenna.

Ports

The table below defines the different ports on the bottom panel.

Port interfaces	Description
DB 15	IDU/ODU interface: <ul style="list-style-type: none"> ▶ Fast Ethernet from/to SDA-4S Type II (also BSDU in the future) ▶ Power from SDA-4S Type II (also BSDU in the future) ▶ TDD Tx/Rx sync from BSDU (future)
DB 9	Engineering applicability (Technical Service only)
RJ45 (with cover)	For future use
N Type RF connector - relevant when implementing external antenna	External antenna connection

MicroMAX-SOC is powered from the indoor integrated LAN switch:

SDA-4S Type II

The SDA-4S Type II indoor unit (hereafter referred to as SDA-4S for convenience) is an integrated LAN switch, providing power and four 10/100BaseT ports for interfacing with the subscriber's network. The unit is displayed in the figure below.

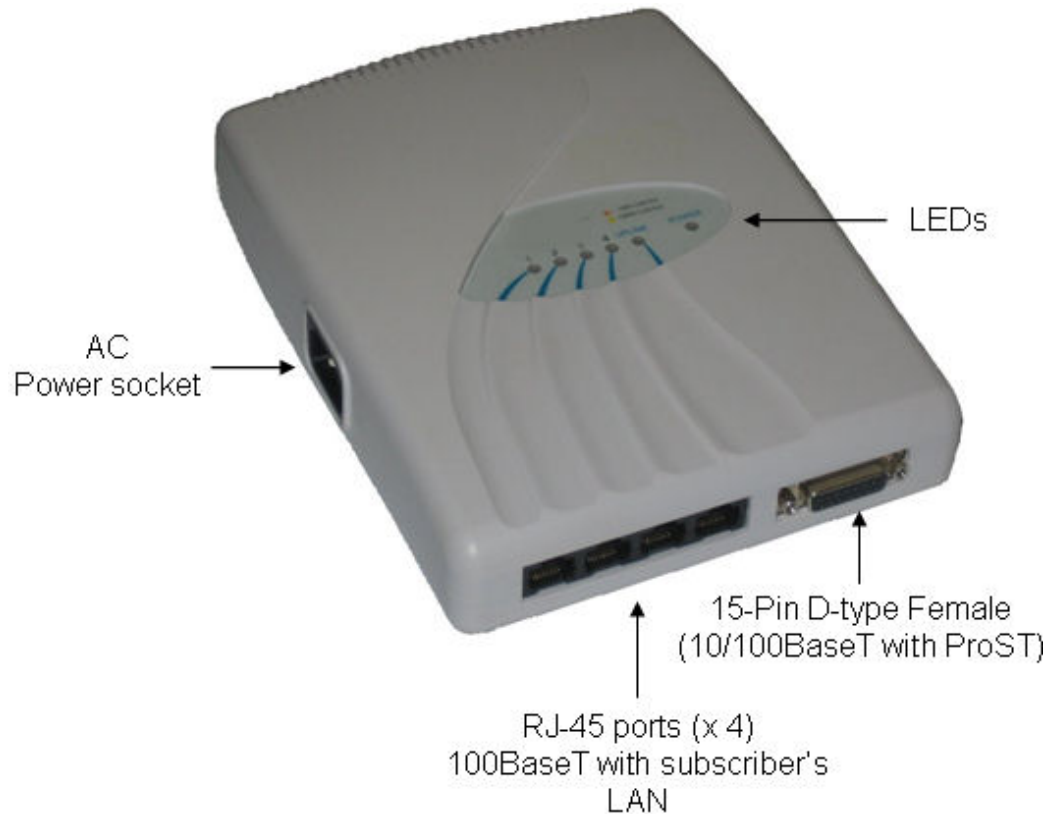

This subsection provides the following SDA-4S physical descriptions:

- ▣ Dimensions
- ▣ Ports
- ▣ LEDs

Physical Dimensions

The SDA-4S physical dimensions are described in the table below:

Parameter	Value
Dimensions	Height - 200mm (7.87 inches) Width - 150mm (5.9 inches) Depth - 40mm (1.57 inches)
Weight	0.53 Kg

Ports

The SDA-4S adapter provides ports on the front panel, which are described in the table below:

Port	Interface
4 x 8-pin RJ-45	10/100BaseT with subscriber's network (supports Auto Negotiation and MDI/MDI-X automatic crossover, allowing connection of straight-through or crossover cables)
15-pin D-type (female)	10/100BaseT with BSR
AC power socket	Subscriber's power outlet (110-240 VAC, 1A, 50/60 Hz, 50W)

 **Note:** The ports of the SDA-4S models support Auto Negotiation, allowing automatic configuration for the highest possible speed link (10BaseT or 100BaseT), and Full Duplex or Half Duplex mode. In other words, the speed of the connected device (e.g. PC) determines the speed at which packets are transmitted through the specific SDA-4S port. In addition, the SDA-4S ports support MDI/MDI-X automatic crossover, allowing connection to straight-through or crossover cables.

LEDs

The SDA-4S adapter provides LED indicators on the top panel, which are described in the table below:

LED	Color	Status	Meaning
UPLINK	Yellow (100BaseT) or Orange (10BaseT)	On	Physical link (10BaseT or 100BaseT) between SDA-4S adapter and BSR
		Blinking	Traffic currently flowing between SDA-4S and BSR
		Off	No link between SDA-4S and BSR
1, 2, 3, 4	Yellow (100BaseT) or Orange (10BaseT)	On	Physical link (10BaseT or 100BaseT) between SDA-4S and subscriber's Ethernet network
		Blinking	Traffic currently flowing between SDA-4S and subscriber's Ethernet network
		Off	No link between SDA-4S and subscriber's Ethernet network
POWER	Green	On	Power received by SDA-4S
		Off	No power received by SDA-4S

The figure below displays the LEDs which are located on the top panel of the SDA-4S Type II adapter:

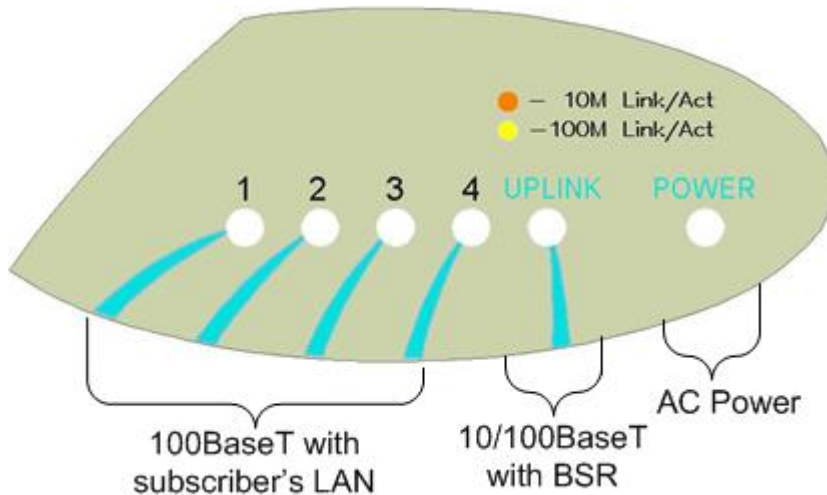

MOUNTING THE BASE STATION RADIO (BSR)

Mounting the MicroMAX-SOC

The MicroMAX-SOC BSR can be pole-mounted or wall-mounted (optional). Pole mounting allows the BSR to be easily adjusted in the horizontal (azimuth) and vertical (elevation) planes for antenna alignment.

For either mounting method, the MicroMAX-SOC provides mounting holes (displayed in the figure below), molded into its back panel for attaching the mounting brackets.

 **Note:** The BSR fully complies with IP Code - IPX6 for product enclosure protection.



Warning: The BSR device is an outdoor radio unit, and therefore, must only be mounted outside.



Warning: Mount the MicroMAX-SOC in an orientation such that its ports (located on the bottom panel) faces downwards. This prevents rain water from settling on the ports, and thereby, avoiding damage to the unit such as corrosion and electrical short-circuiting.

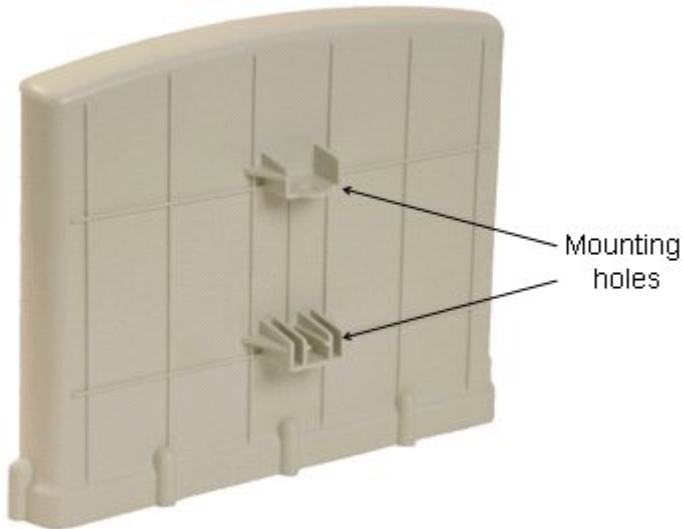

 **Note:** The standard BSR kit, provides pole-mounting brackets. If you want to wall-mount the MicroMAX-SOC, contact your Airspan distributor for pricing and ordering of wall-mounting brackets.

Pole-Mounting the BSR

Pole mounting allows the MicroMAX-SOC to be easily adjusted in the horizontal (azimuth) and vertical (elevation) planes for antenna alignment. The BSR is mounted using the mounting holes located on the BSR's back panel and the supplied pole-mounting brackets. The pole-mounting bracket is designed to support the BSR on a round pole of 45 mm in diameter.

The figure below summarizes of the MicroMAX-SOC's pole-mounting procedure.

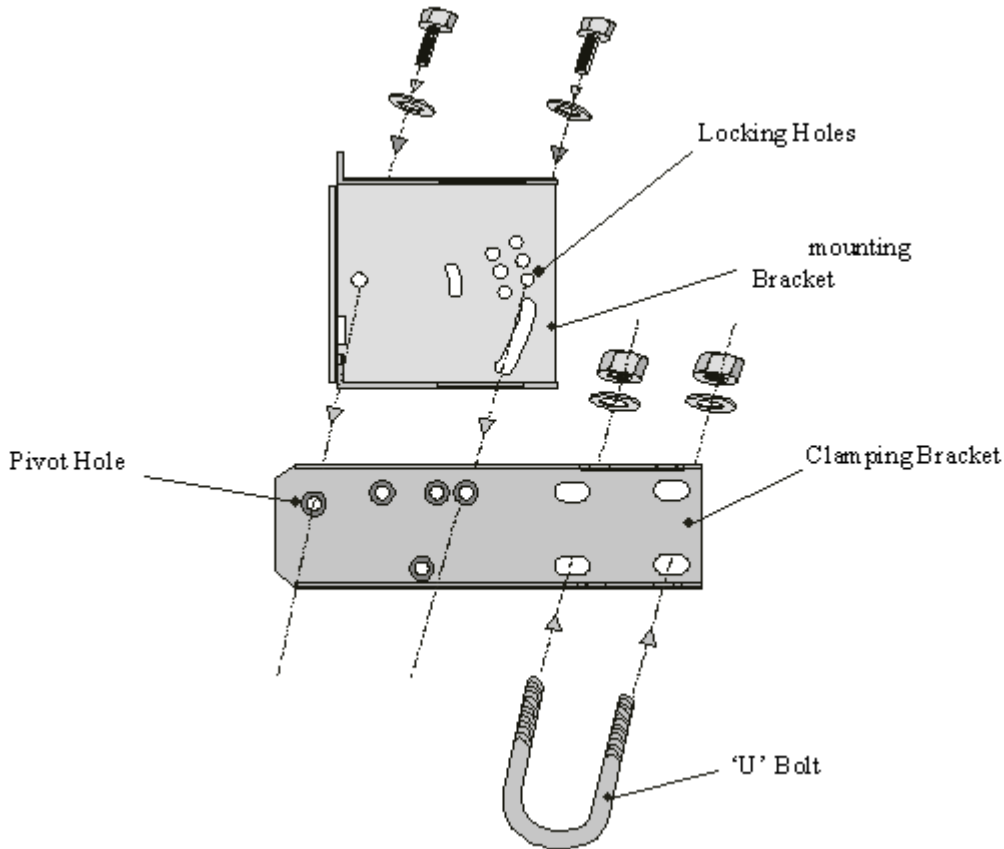

To pole mount the MicroMAX-SOC BSR:

1. Attach the mounting bracket to the MicroMAX-SOC:
 - a. Align the mounting bracket with the MicroMAX-SOC's mounting holes so that the mounting bracket's side with the built-in nut is aligned with the BSR's mounting holes furthest from the MicroMAX-SOC's bottom panel, as shown in the figure below.
 - b. Slide an M10-flat washer and M10-spring lock washer onto an M10-hex head screw (ensure spring lock washer is closest to the bolt's head). From the external side, insert the M10-hex head screw through the mounting bracket and MicroMAX-SOC's mounting holes. Fasten the M10-hex head screw (one is provided with a built-in nut while the other requires you to insert an M10-hex nut into the MicroMAX-SOC's mounting hole).

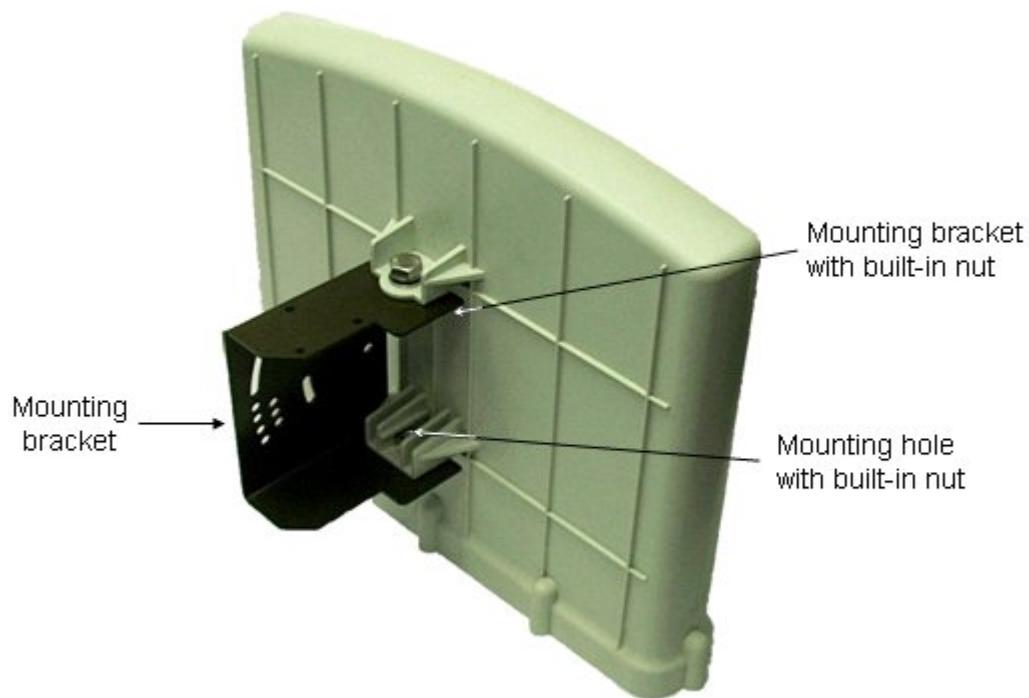

2. Attach the clamping bracket to the mounting bracket:
 - a. Slide an M6-spring lock washer onto an M6-hex head screw. Align the mounting bracket's and clamping bracket's pivot holes, such that the clamping bracket is aligned to the inside of the mounting bracket. From the external side of the mounting bracket, insert the M6-hex head screw into the pivot holes and then fasten, but not tightly. (The clamping bracket provides a built-in nut.)
 - b. Choose an elevation hole on the mounting bracket and then align it with the corresponding hole on the clamping bracket. Slide an M6-spring lock washer onto an M6-hex head screw, and then from the external side of the mounting bracket, insert the M6-hex head screw through the elevation hole on the mounting bracket and into the clamping bracket's corresponding hole. Fasten but not tightly the M6-hex head screw (the clamping bracket provides built-in nut). The elevation hole can later be changed according to desired antenna orientation in the elevation plane.

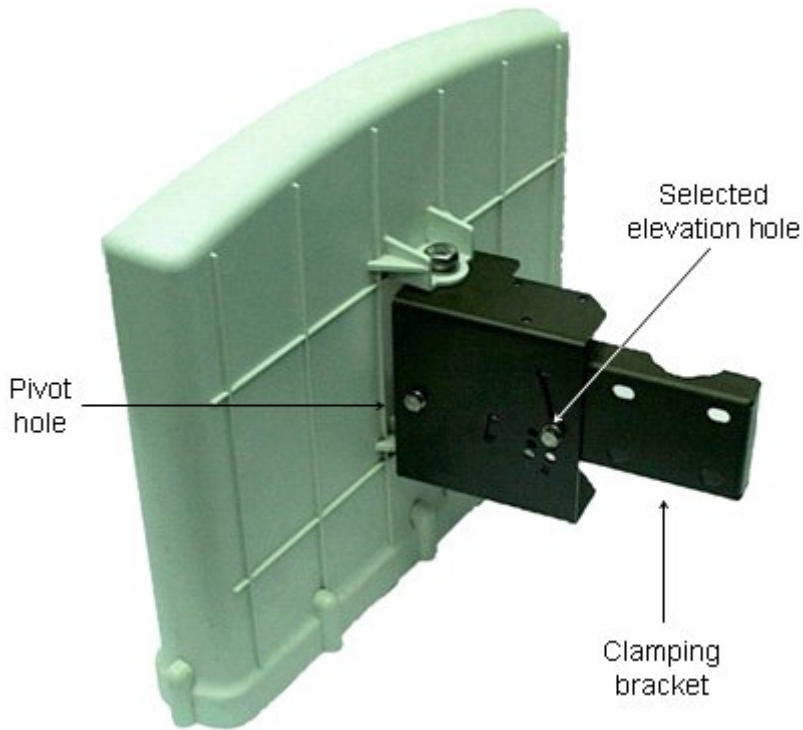

3. Attach the U-bolt to the pole:
 - a. Place one U-bolt around the pole, and then insert the U-bolt screw side through the two corresponding holes (horizontally parallel) on the clamping bracket. Slide an M8-flat washer and M8-spring lock washer onto each U-bolt screw side (ensure that the flat washer is adjacent to the clamping bracket). Fasten each U-bolt side with the two M8-hex nuts.
 - b. Attach the second U-bolt as described above.

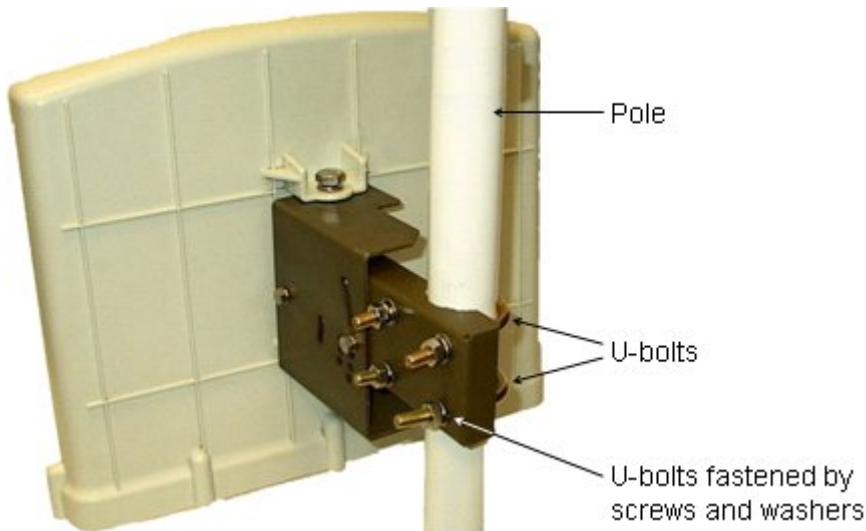

4. Perform final MicroMAX-SOC orientation:
 - a. Adjust the vertical position of the MicroMAX-SOC by choosing a final elevation hole as described in Step 2. Lock the MicroMAX-SOC at the desired position by inserting the locking bolt in the desired position and fastening it tightly. Fasten tightly the bolt in the pivot hole. The figure below illustrates the angles (in degrees) of each elevation hole. As shown, the MicroMAX-SOC pole-mounting bracket allows elevation between -18.5° and 26.3° .

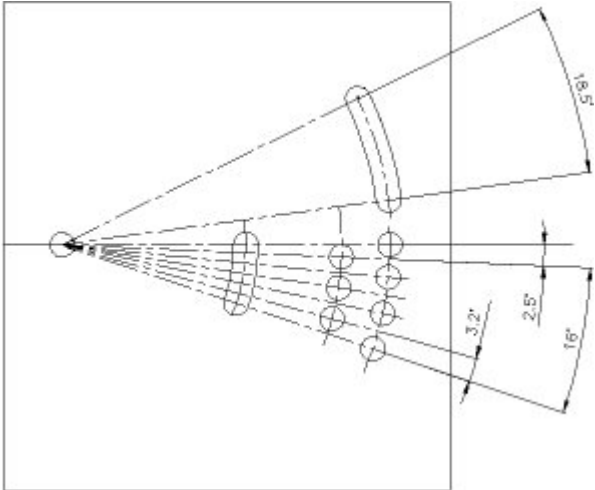

- b. Adjust the horizontal position of the MicroMAX-SOC by rotating it about the pole, and then tightening the nuts of the U-bolts.

 **Note:** A thread-locking compound must be used to prevent the bolts from working loose.

MicroMAX-SOC positioning is obtained in two planes by adjustment of the mounting bracket assembly as shown below.

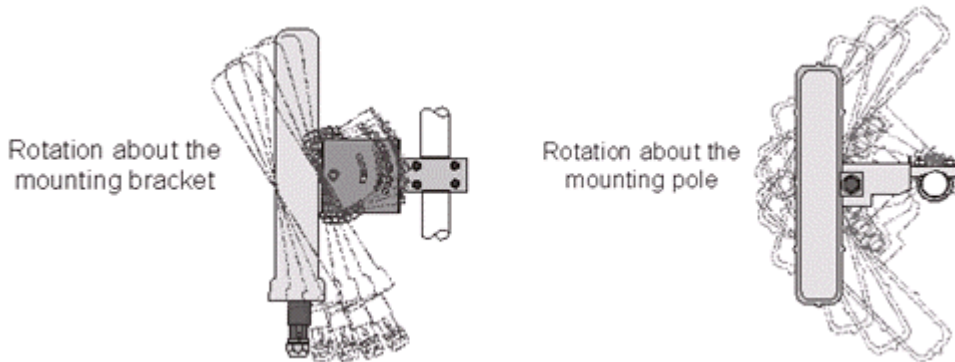

It is important to provide strain relief and drip loop for Cat-5 cables. Create a drip loop and strain relief using cable tie, to tie cable to pole, as displayed in the figure below:



Wall-Mounting the BSR (Optional)

 **Note:** The standard BSR kit provides pole-mounting brackets. If you want to wall-mount the MicroMAX-SOC BSR contact your Airspan distributor for pricing and ordering of wall-mounting brackets.

 **Note:** A minimum of 3-meter separation is required between mounted MicroMAX-SOC's and existing customer radio equipment when transmitting on different sectors (see figure below). However, only a 1-meter separation is required between MicroMAX-SOC's when on the same sector and transmitting to the same base station radio without requiring shielding.

The figure below illustrates the minimum separation between mounted MicroMAX-SOC's when transmitting on different sectors:

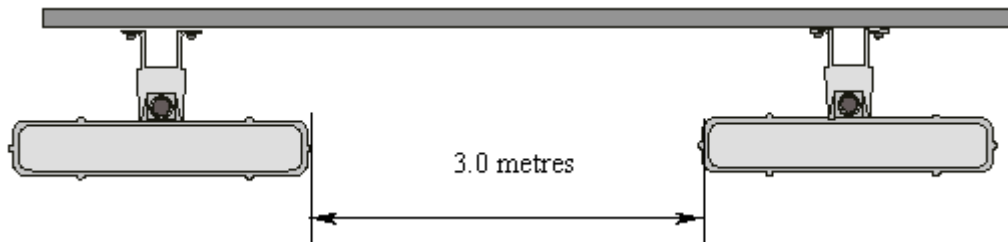

MicroMAX-SOC wall mounting consists of two main stages:

- ▶ Attaching the mounting bracket to the MicroMAX-SOC's mounting holes
- ▶ Attaching the mounting bracket (already attached to the MicroMAX-SOC) to the wall (or pole)

To wall mount the MicroMAX-SOC:

1. Position the unassembled mounting bracket on the mounting surface (e.g. wall), and then use a pencil to mark the position of the four mounting holes. Ensure that the distance between the hole centers are 120 mm (height) and 60 mm (width), as displayed in the figure below showing the MicroMAX-SOC's fixing dimensions.

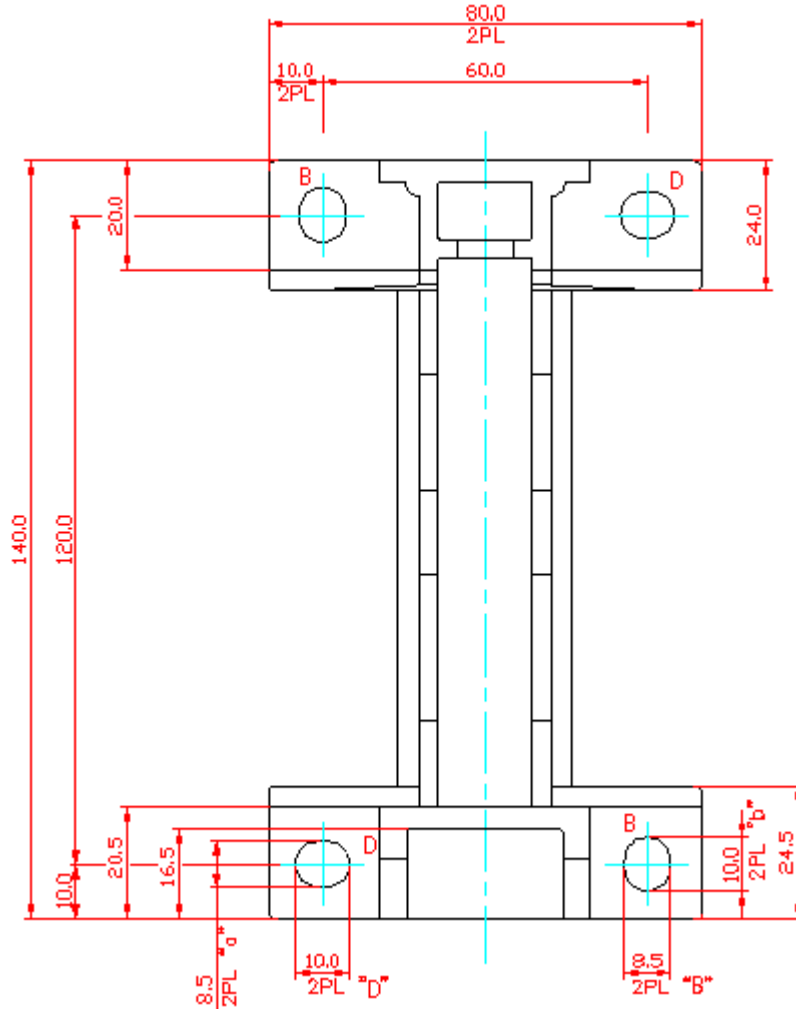

2. Drill holes for each hole that you marked in the step above.
3. Insert wall anchors (not supplied) into each of the drilled holes.
4. Align the mounting bracket's four holes with the wall anchors, and then insert a screw (not supplied) through the mounting bracket holes into each wall anchor, and then tighten.

 **Note:** Airspan does not provide screws for attaching the mounting bracket to the wall. The screw size depends on the structure of the building to which the bracket is to be attached. When selecting screw sizes, consideration must be given to the weight of the MicroMAX-SOC and load that may be induced in windy conditions.

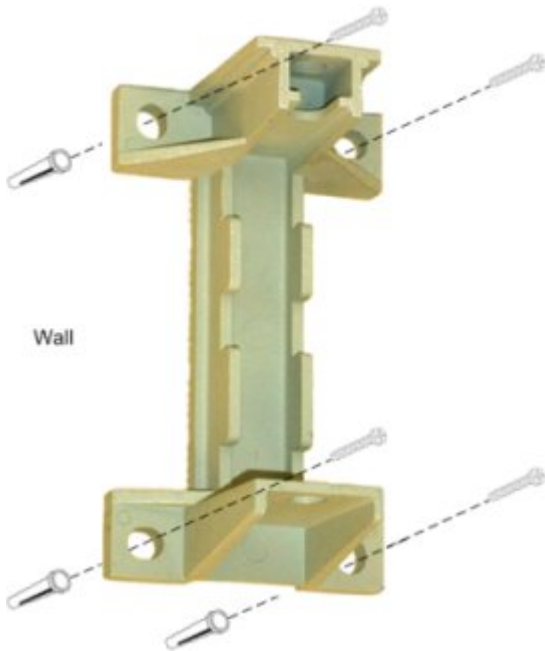

5. Attach the MicroMAX-SOC to the mounting bracket by performing the following:
 - a. Slide an M10-spring lock washer and then an M10-plain washer onto each M10-hex head screw (ensure lock washer is nearest to head of screw bolt).
 - b. Align the mounting bracket's holes with the MicroMAX-SOC's mounting holes as displayed below. (The mounting bracket side that provides a groove for inserting a nut must be aligned with the MicroMAX-SOC's mounting hole that is nearest to the MicroMAX-SOC's bottom panel.)
 - c. From the external sides, insert the M10-hex head screws through the mounting bracket's holes and MicroMAX-SOC's mounting holes. Loosely fasten with the M10-hex nuts.

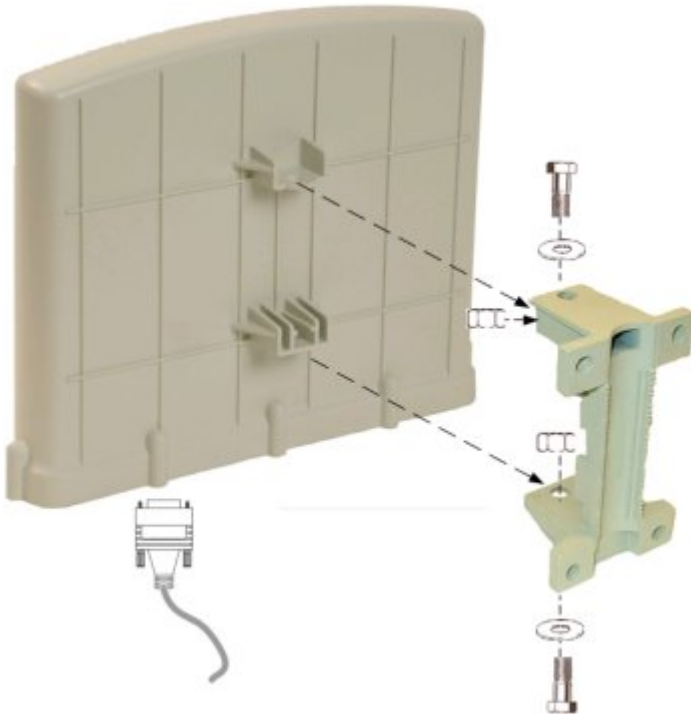

6. Adjust the horizontal positioning of the MicroMAX-SOC (see "Web-Based Management" for MicroMAX-SOC antenna alignment using RSS measurements), and then tighten the two M10-hex head screws with the M10 hex nuts.

 **Note:** A third-party thread-locking compound must be applied to the M10-hex head screws to prevent the bolts from working loose.

 **Note:** For wall mounting, rotation is restricted in the horizontal plane only.

Installing the SDA-4S Type II

The SDA-4S Type II is mounted vertically on a wall.

Wall Mounting

Wall mounting is made possible by the existence of two mounting hooks molded into the SDA-4S's bottom panel, as displayed in the figure below.



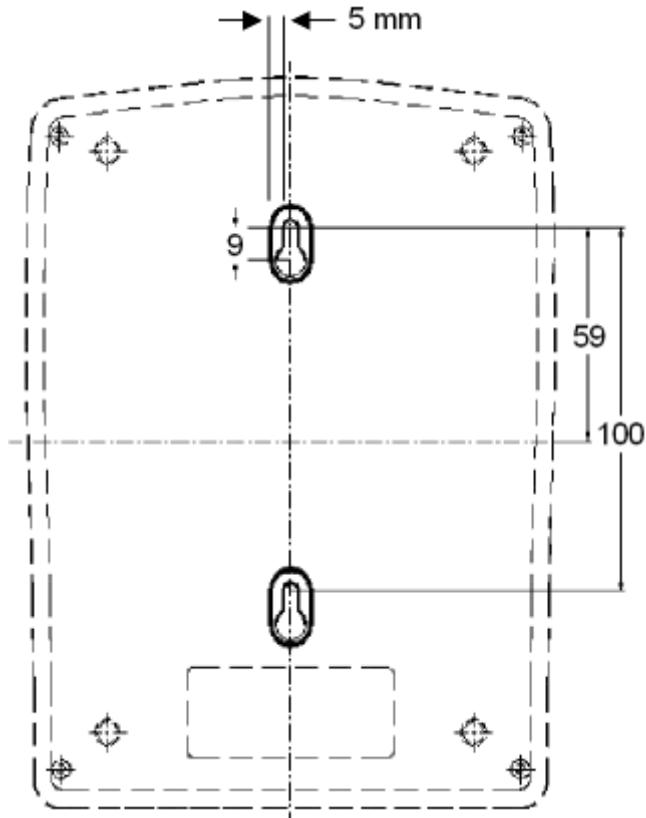

To wall mount the SDA-4S:

1. On the wall, mark the position of the two mounting hooks. The dimensions of the wall-mounting hooks are displayed in the template below.



2. Drill holes for each hole that you marked in the step above.
3. Insert wall anchors (supplied) into each of the drilled holes.
4. Insert the 9-inch screws (supplied) into the wall anchors. Ensure at least 2 mm of the screw is exposed to allow insertion into the SDA-4S mounting holes.
5. Hold the SDA-4S with both hands, and align the entrance to the two mounting hooks with the screws. Slide the screws into the mounting hooks, by lowering the SDA-4S onto the screws.

 **Note:** For safety, both mounting hooks must be utilized when mounting the unit.

 **Note:** The SDA-4S is supplied with a 1-metre AC power lead assembly. Therefore, ensure the unit is mounted within reachable distance to the customer's mains power outlet.

 **Note:** The maximum cable run between SDA-4S and MicroMAX-SOC is 100 meters. Therefore, ensure the unit is mounted within reachable distance.

CABLING THE BSR

Connecting the BSR to the SDA-4S

The SDA-4S provides -48 VDC power to the BSR as well as the Fast Ethernet interface between the BSR and the provider's backhaul network. The outdoor Base Station Radio and Modem are powered over a CAT5e Cable by the SDA-4S Type II IDU in the minimum configuration. For larger configurations N* SDA-4Ss and N* BSRs are required.

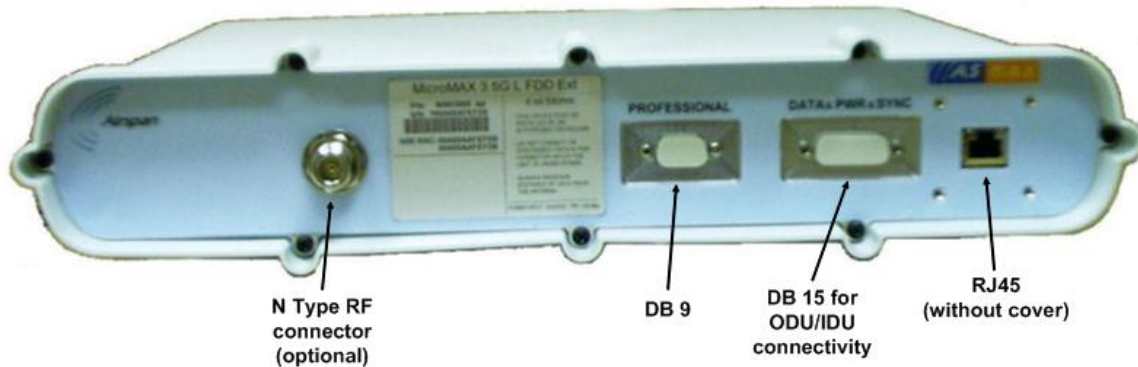

The BSR interfaces with the subscriber's Ethernet network through the SDA-4S. To connect the BSR to the SDA-4S, you need to connect the BSR's 15-pin D-type port to the SDA-4S's 15-pin D-type port using a CAT-5e cable.

The cable setup for MicroMAX-SOC-to-SDA-4S connectivity is as follows:

- ▣ **Cable:** Straight-through CAT 5e Ethernet cable
- ▣ **Connectors:**
 - MicroMAX-SOC: DB15-to-RJ45 outdoor adapter
 - SDA-4S: DB15-to-RJ45 indoor adapter (for connecting to DATA&PWR&SYNC D-type connector)
 - CAT 5e cable with 8-pin RJ-45 male connectors on either end
- ▣ **Connector pinouts:**

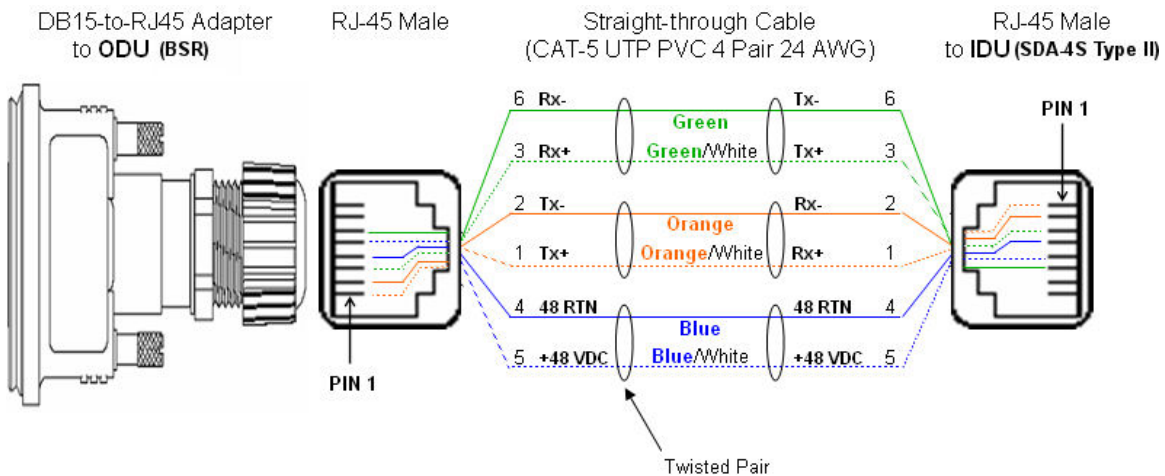

Note: The wire color-coding described in the table is Airspan's standard for wire color-coding. However, if you implement your company's wire color-coding scheme, ensure that the

wires are paired and twisted according to pin functions listed in the table above (e.g. Rx+ with Rx-).

 **Note:** The maximum CAT 5 cable length for ODU/IDU connectivity is 100 meters.

To connect the BSR to the SDA-4S:

1. Connect the 15-pin D-type male connector, at one end of the CAT 5e cable, to the BSR's 15-pin D-type port labeled DATA&PWR&SYNC.
2. Connect the 15-pin D-type male connector, at the other end of the CAT 5e cable, to the SDA-4S's 15-pin D-type port.

SDA-4S Type II

Using the SDA-4S Type II

The SDA-4S Type II provides one to four RJ-45 (100BaseT) ports for interfacing with the subscriber's LAN network.

The ports of the SDA-4S model support Auto Negotiation, allowing automatic configuration for the highest possible speed link (10BaseT or 100BaseT), and Full Duplex or Half Duplex mode. In other words, the speed of the connected device (e.g. PC) determines the speed at which packets are transmitted through the specific port. For example, if the device to which the port is connected is running at 100 Mbps, the port connection will transmit packets at 100 Mbps. Conversely, if the device to which the port is connected is running at 10 Mbps, the port connection will transmit packets at 10 Mbps.

In addition, the SDA-4S ports support MDI/MDI-X automatic crossover, allowing connection to straight-through or crossover CAT 5e cables. Therefore, these ports can be connected to either a hub (i.e. using crossover cables) or a PC (i.e. using straight-through cables).

The cable setup for SDA-4S LAN connectivity is as follows:

- ▣ **Cable:** Straight-through (e.g. when connecting to PC) or crossover (i.e. when connecting to a hub) CAT 5e Ethernet cable
- ▣ **Connectors:** 8-pin RJ-45 at both ends
- ▣ **Connector pinouts:**
 - Straight-through cable (e.g. connecting to a PC)

CONNECTING THE SDA-4S TO THE POWER SUPPLY

Connecting the SDA-4S Type II

The SDA-4S adapters are plugged into a standard electrical wall outlet (110/240 VAC) using an AC power cord. The appropriate AC power cord is supplied according to the country of use

The cable setup between the SDA-4S and power outlet includes the following:

- ▶ **Connector:** AC IEC 60320 type (female)
- ▶ **Plug:** The appropriate plug type is supplied according to the country of use
- ▶ **Cable:** 3x1.20 mm, 10A / 250 VAC (maximum length is 180 cm)

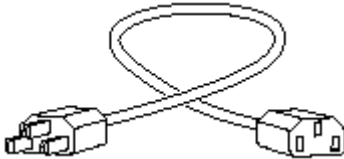

To connect the SDA-4S to the AC power supply:

1. Connect the power plug female, at the end of the AC power chord, into the AC power socket located on the left panel of the SDA-4S.
2. Plug the power plug male, at the other end of the AC power chord, into the AC power outlet (110-240 VAC).
3. Verify that the power is received by the SDA-4S by checking that the **POWER** LED light is on.

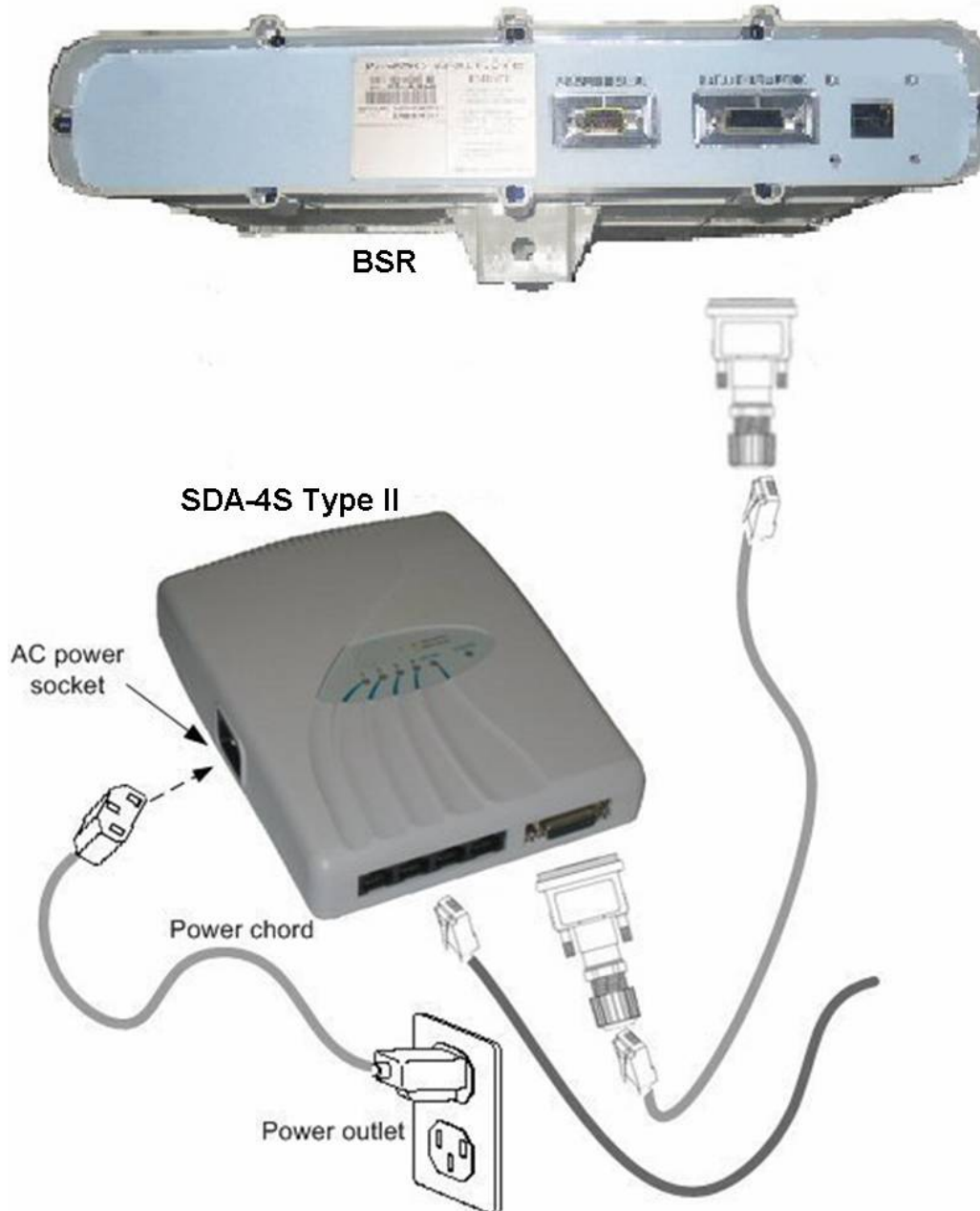

4. Verify that your SDA-4S is on and receiving power by checking that the LED labeled **POWER** is lit (see SDA-4S LED description).

Connecting SDA-4S to Ethernet Network

The MicroMAX-SOC typically interfaces with the subscriber's network/computer using the SDA-4S Type II which provides four (10/100BaseT) LAN ports for interfacing with the subscriber's LAN network.

Connecting Lightning and Surge Protector

The optional third-party lightning and surge protector (PolyPhaser) is implemented in the following deployment scenarios:

- ▣ ODU-to-IDU cable length of 40 meters or more (**mandatory to use surge protector**)

- Deployment of MicroMAX-SOC in geographical areas that frequently experience severe lightning storms

The lightning and surge protector protects the ODU-to-IDU CAT 5e cable's six used wires (two -48 VDC wires and four Ethernet Tx and Rx wires) from any electrical surges due to lightning strikes.

The protector is installed outdoors on the CAT 5e cable that connects between the MicroMAX-SOC and the SDA-4S Type II. In other words, two CAT 5e cables are required for the following connections:

- MicroMAX-SOC-to-protector connection
- Protector-to-IDU connection



Warning: Do not install the lightning and surge protector during adverse weather conditions when the threat of lightning strike is possible.



Note: The protector unit must be grounded to a low-impedance (low R and low L) ground system to operate properly.



Note: For pricing and ordering of the PolyPhaser lightning and surge protector, contact your Airspan representative.

To install the lightning protector:

- Connect the protector in the direction according to the labels. The end labeled SURGE accepts the cable from the MicroMAX-SOC; the end labeled PROTECTED accepts the cable from the SDA-4S.
- Feed the CAT 5e cable through the grommet (for each side). If the RJ-45 connector is already crimped to the other end, ensure that you have fed the cable through the gland nut beforehand. The gland nut secures the cable to the grommet.
- Strip about 0.25" (6.35 mm) of the cable sheath and expose about 0.03" (0.8 mm) of the strands/wires.
- Secure the wires to the protector's terminal block using the two spot ties. Each side of the data and DC assembly has + or - markings to ensure lines entering (surge side) match lines exiting (protected side).

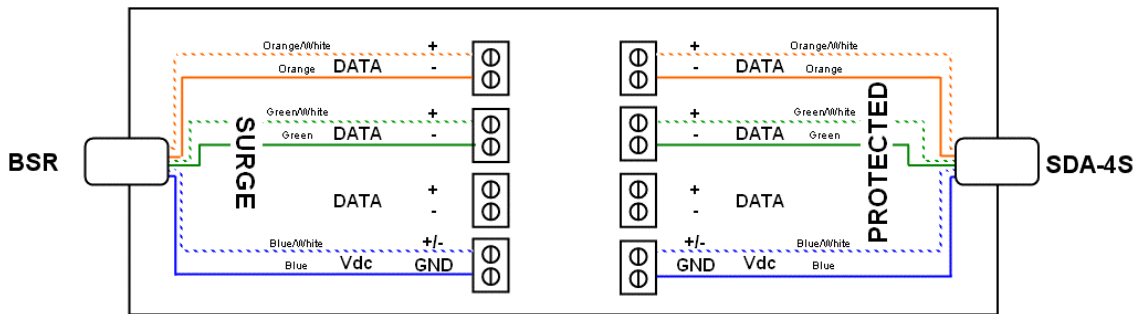

Legend:

Rx+	Orange/White
Rx-	Orange
Tx-	Green/White
Tx+	Green
+48 VDC	Blue/White
48 RTN	Blue

- Mount and ground the protector outdoors with the provided 2 x 8-32 screws according to the fixing template illustrated below (showing distances between centers of the two

mounting holes). The unit may be mounted/grounded on a nearby plate or bulkhead panel that is bonded to an earth-ground system.

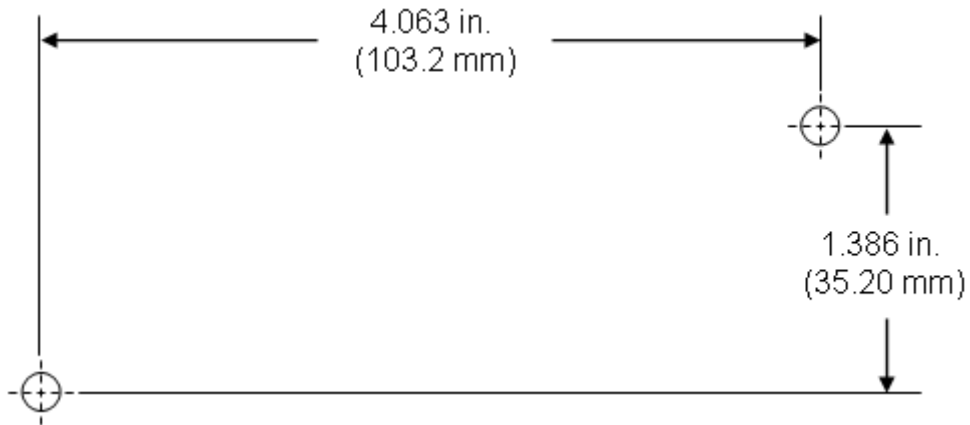

6. Attach the protector's lid by using the four M4 x 20-mm screws. Ensure that the neoprene gasket on the lid is not loose or out of the groove.
7. Secure the CAT 5e cable to the grommet by fastening the gland nut.

The figure below illustrates the connectivity of the lightning and surge protector.

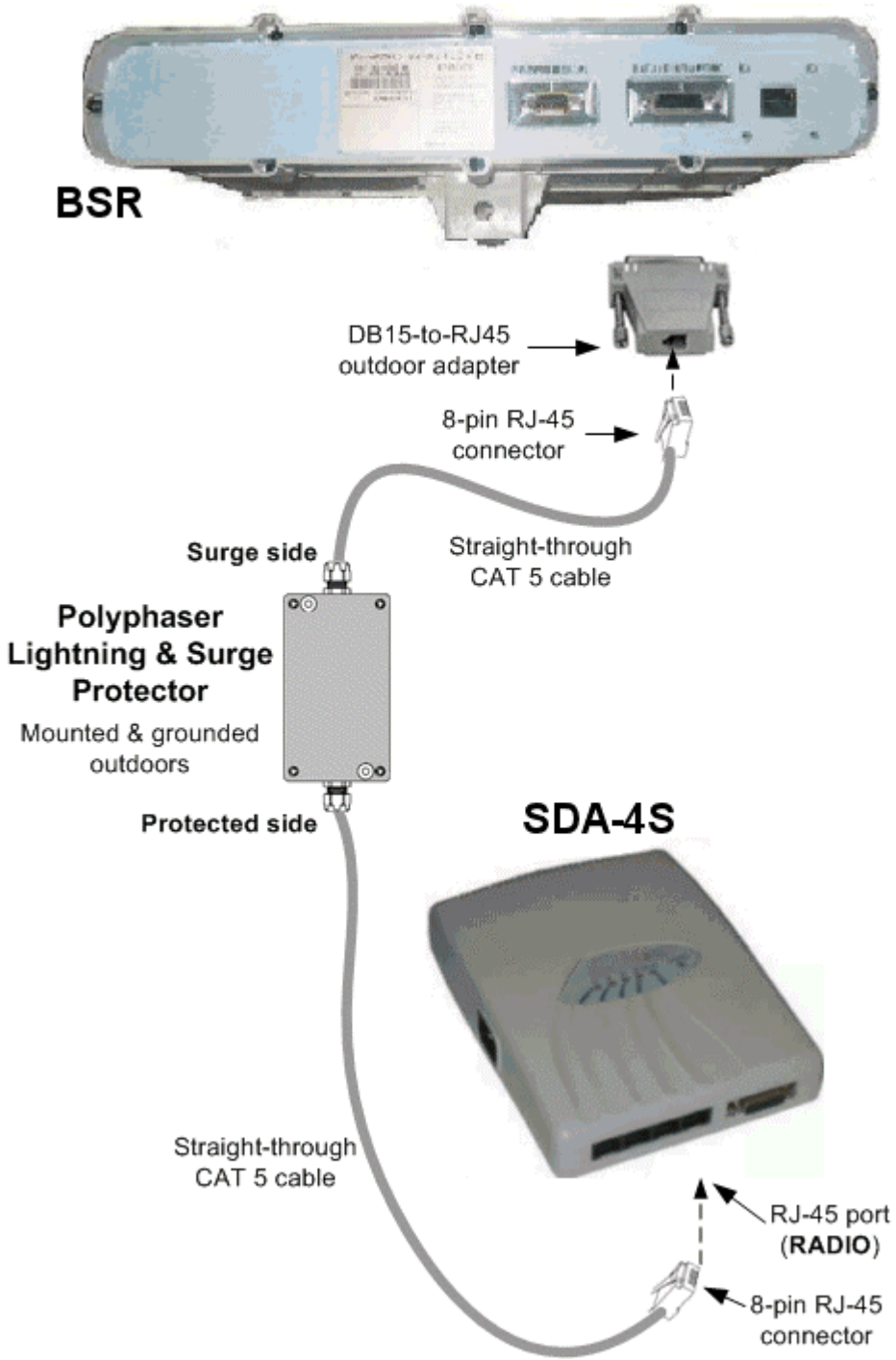

CONNECTING AN EXTERNAL ANTENNA

Connecting Third Party External Antenna

The MicroMAX-SOC BSR model without a built-in antenna provides an N-type port for connecting a third-party external antenna. The addition of an external antenna allows greater RF sector coverage than the standard MicroMAX-SOC BSR built-in antenna model.



Warning: Before connecting the external antenna, ensure that the MicroMAX-SOC is not connected to the power source.



Warning: Before powering on the MicroMAX-SOC, ensure that some type of equipment such as an antenna or an RF attenuator is connected to the N-type receptacle. This eliminates the risk of irreversibly damaging the MicroMAX-SOC device.



Warning: It is the responsibility of the person installing the MicroMAX-SOC to ensure that only those antennas certified with the product are used. The use of any antenna other than those certified with the product is expressly forbidden.



Warning: The external antenna must not be co-located or operating in conjunction with any other antenna or transmitter.



Warning: The MicroMAX-SOC and external antenna should be installed ONLY by experienced installation professionals who are familiar with the local building and safety codes and are licensed by the appropriate government authorities.



Note: The MicroMAX-SOC model that provides an N-type connector for attaching a third-party external antenna does not contain an internal, built-in antenna.

The following lists the cable setup for attaching the external antenna:

- ▣ Cable: RF coaxial
- ▣ Connector: N-type male

To connect a third-party external antenna to the MicroMAX-SOC:

- ▣ Connect the N-type male connector of the third-party antenna to the N-type receptacle located on the MicroMAX-SOC's panel (labeled ANTENNA), as displayed below.

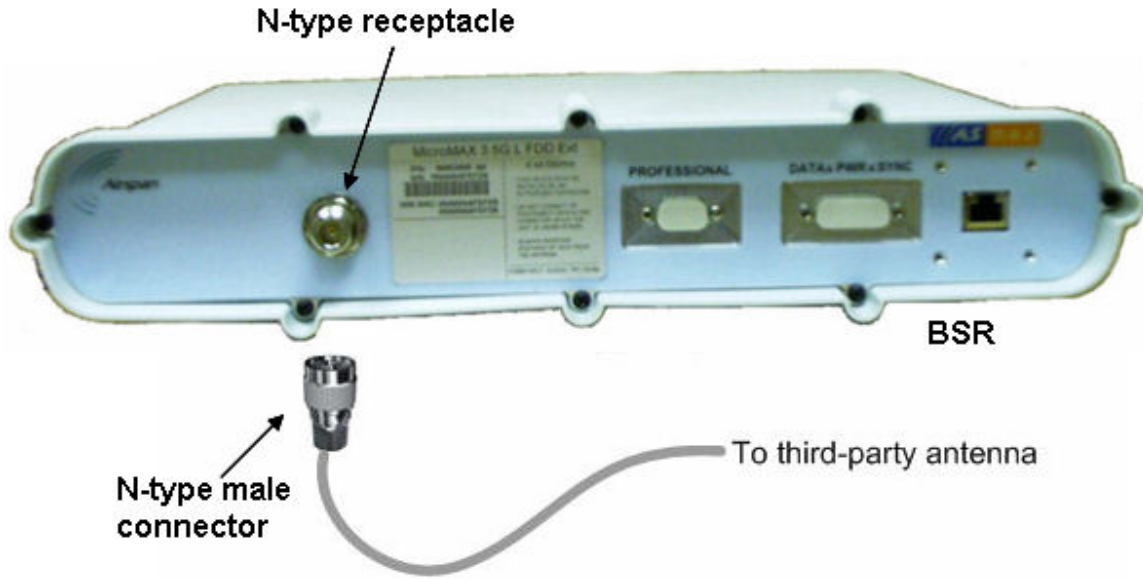

TRADEMARKS AND COPYRIGHTS

1. ©Airspan Networks Inc 2006
2. The information in this document is proprietary to Airspan Networks Inc. This document may not in whole or in part be copied, reproduced, or reduced to any medium without prior consent, in writing, from Airspan Networks Incorporated.
3. This manual is subject to revision.
4. All rights reserved.
5. Right of modification reserved.
6. This manual is supplied without liability for errors or omissions.
7. No part of this manual may be reproduced or used except as authorised by contract or other written permission.
8. This equipment is conditioned by the requirement that no modifications are made to the equipment unless the changes or modifications are expressly approved by the Airspan Communications Corporation
9. Prerequisite skills: Personnel installing, commissioning, and maintaining the Airspan products must have a basic knowledge of telephony and radio communications, and have experience in installing, commissioning and maintaining telecommunications products. Airspan provides a range of comprehensive training courses specifically aimed at providing operators/users of Airspan products with the prerequisite skills to install, commission and or maintain the product. The courses are tailored to provide the level of training required by the operator/user.
10. AS MicroMAX-SOC, AS8200 and Netspan are brands of Airspan Networks Inc.

CONTACT INFORMATION

Customer Service Help-Desk for customer service emergency

Airspan Communications Limited
Cambridge House
Oxford Road
Uxbridge
Middlesex
UB8 1UN.

Int. Tel: +44 (0) 1895 467 467

Int. Fax: +44 (0) 1895 467 472

E-mail: Support@Airspan.com

UK Office for sales and general enquiries

Airspan Communications Ltd
Cambridge House
Oxford Road
Uxbridge
Middlesex
UB8 1UN.

Call +44 (0) 1895 467100

Fax +44 (0) 1895 467101

email sales@ airspan.com

Internet: Airspan.com

REVISIONS

Revision Level	Date	Main Changes
01	4-4-2006	Initial Document
A	09-05-2006	additional content
B	26-06-2006	corrections
C	27-06-2006	added PolyPhaser
D	10-08-2006	corrections

WARNINGS

1. Disclaimer

Every effort has been made to ensure the accuracy of the material provided herein; however, Airspan assumes no responsibility regarding the use of the material. Additionally, Airspan makes no representations or warranties, either expressed or implied, regarding the contents of this product. Airspan Networks Inc. shall not be liable for any misuse regarding this product.

Any product performance limits stated within this document are for information purposes only and should be considered as indicative.

1.1 Safety Warnings

1. Read this User Manual and follow all operating and safety instructions.
2. Keep all product information for future reference.
3. This product is supplied with a grounding power plug. Do not defeat this important safety feature.
4. **Warning:** High voltages exist inside the product - do not remove the lid or base: No user serviceable parts inside.
5. **CAUTION: DOUBLE POLE/NEUTRAL FUSING** - Always replace the fuse with the correct type and current rating.
6. Position the power cord to avoid possible damage; do not overload wall outlets.
7. Do not place this product on or near a direct heat source, and avoid placing objects on the terminal.
8. Do not operate this device near water or in a wet location.
9. Use only a damp cloth for cleaning. Do not use liquid or aerosol cleaners. Disconnect the power before cleaning.
10. Protect the terminal by disconnecting the power if not used for long periods.
11. Mount the terminal in a Telco rack on a stable horizontal surface.
12. The radio antenna units must not be located near power lines or other electrical power circuits.
13. The radio transceiver must be properly grounded to protect against power surges and accumulated static electricity. It is the user's responsibility to install this device in accordance with the local electrical codes: correct installation procedures for grounding of the transceiver unit, mast, lead-in wire and discharge unit, location of discharge unit, size of grounding conductors and connection requirements for grounding electrodes.
14. Installation of the transceiver must be contracted to a professional installer.
15. Disconnect Device. The socket outlet shall be installed near the equipment, easily accessible and will act as the disconnect for the MicroMAX-SOC.
16. When installed in the final configuration, the product must comply with the applicable Safety Standards and regulatory requirements of the country in which it is installed. If necessary, consult with the appropriate regulatory agencies and inspection authorities to ensure compliance.

1.2 Important Warning Symbols

The following symbols may be encountered during installation or troubleshooting. These warning symbols mean danger. Bodily injury may result if you are not aware of the safety hazards involved in working with electrical equipment and radio transmitters. Familiarize yourself with standard safety practices before continuing.

**Electro-Magnetic Radiation****High Voltage**

1.3 Important Service Information

1. Refer all repairs to qualified service personnel. Do not remove the covers or modify any part of this device, as this will void the warranty.
2. Disconnect the power to this product and return it for service if the following conditions apply:
 - a. The terminal does not function after following the operating instructions outlined in this manual.
 - b. Liquid has been spilled, a foreign object is inside, or the terminal has been exposed to rain.
 - c. The product has been dropped or the housing is damaged.
3. Locate the serial number of the terminal, antenna, and transceiver and record these on your registration card for future reference. Use the space below to affix serial number stickers. Also record the MAC address, located on the back of the terminal.

1.4 UL Information

- The equipment must be properly grounded according with NEC and other local safety code requirements
- Reminder to all the BWA system installers: Attention to Section 820-40 of the NEC which provides guidelines for proper grounding and, in particular, specifies that the cable ground shall be connected to the grounding system of the building, as close to the point of cable entry as is practical.

1.5 CE Notice

The MicroMAX-SOC shelf carries the CE mark to demonstrate conformity with the Radio Equipment and Telecommunications Terminal Equipment and the Mutual recognition of their conformity (R&TTE) directive 1999/5/EC.

WARNING: This is a class A product. In a domestic environment this product may cause radio interference in which case the user may be required to take adequate measures.

Installation

The transceiver and antenna equipment must be installed by a qualified professional installer and must be installed in compliance with regional, national, and local regulations. It is the responsibility of the system installer and/or system operator to ensure the installed system does not exceed any operational constraints identified by local regulations.

Refer to the sections in this product User Guide for detailed information about the correct installation steps to ensure power and frequency settings are set correctly before connecting the antenna.

Antenna Selection

Refer to the product User Guide for a list of Airspan Networks approved antennas. Antennas not listed in the User Guide are outside the scope of this Declaration.

CAUTION: European Directive 1999/519/EC details basic restrictions and reference levels on human exposure to electromagnetic fields as advised by the ICNIRP. The directive states that adherence to these recommended restrictions and reference levels should provide a high level of protection as regards the established health effects that may result from exposure to such fields.

By the very nature of the system design and installation users will not find them selves within close proximity of the subscriber terminals.

Standards EN50383 and EN50385 are the applicable harmonised standards for EM fields generated by fixed wireless equipment.

The Electromagnetic fields generated by the Central Terminal antenna are below the recommended safe levels at all distances greater than 65 cm from an approved Airspan antenna.

The safe distance from a non-approved antenna of length D and Sector Angle δ may be calculated using the formula:

Safe distance, $r = 36 / (n * D * \delta)$

1.6 European Community, Switzerland, Norway, Iceland, and Liechtenstein

Declaration of Conformity with Regard to the R&TTE Directive 1999/5/EC

English:

This equipment is in compliance with the essential requirements and other relevant provisions of Directive 1999/5/EC.

Deutsch:

Dieses Gerät entspricht den grundlegenden Anforderungen und den weiteren entsprechedenen Vorgaben der Richtlinie 1999/5/EU.

Dansk:

Denne udstyr er i overensstemmelse med de væsentlige krav og andre relevante bestemmelser i Directiv 1999/5/EF.

Español:

Este equipo cumple con los requisitos esenciales asi como con otras disposiciones de la Directive 1999/5/EC.

Ελληνικά:

Αυτός ο εξοπλισμός συμμορφώνεται με τις ουσιώδεις απαιτήσεις και τις λοιπές διατάξεις της Οδηγίας 1999/5/EK.

Français:

Cet appareil est conforme aux exigences essentielles et aux autres dispositions pertinentes de la Directive 1999/5/EC.

Íslenska:

Þessi búnaður samrýmist lögboðnum kröfum og öðrum ákvæðum tilskipunar 1999/5/ESB.

Italiano:

Questo apparato é conforme ai requisiti essenziali ed agli altri principi sanciti dalla Direttiva 1999/5/EC.

Nederlands:

Deze apparatuur voldoet aan de belangrijkste eisen en andere voorzieningen van richtlijn 1999/5/EC.

Norsk:

Denne utstyret er i samsvar med de grunnleggende krav og andre relevante bestemmelser i EU-directiv 1999/5/EC.

Português:

Este equipamento satisfaz os requisitos essenciais e outras provisões da Directiva 1999/5/EC.

Suomalainen:

Tämä laite täyttää direktiivin 1999/5/EY oleelliset vaatimukset ja on siinä asetettujen muidenkin ehtojen mukainen.

Svenska:

Denna utrustning är i överensstämmelse med de väsentliga kraven och andra relevanta bestämmelser i Direktiv 1999/5/EC.

The Declaration of Conformity related to this product can be obtained from product_management@Airspan.com

1.7 CAUTION

Any modifications to this device not expressly authorised by the manufacturer could void the user's authority to operate this device.

Responsible party for compliance is:

David Mann, Airspan Networks Inc., Cambridge House, Oxford Rd, Uxbridge, Middlesex, England, UB8 1UN. Telephone (44) 1 895 467450.

1.8 Lightning Protection

WARNING: The following notes are general recommendations for the system. The wireless equipment should be installed by a qualified professional installer and must follow local and national codes for electrical grounding and safety. Failure to meet safety requirements and/or use of non-standard practices and procedures could result in personal injury and damage to equipment. A direct lightning strike may cause serious damage even if these guidelines are followed.

All outdoor wireless equipment is susceptible to lightning damage from a direct hit or induced current from a near strike. Lightning protection and grounding practices in local and national electrical codes serve to minimize equipment damage, service outages, and serious injury. Reasons for lightning damage are summarized as:

- Poorly grounded tower/antenna sites that can conduct high lightning strike energy into equipment.
- Lack of properly installed lightning protection equipment that can cause equipment failures from lightning induced currents.

A lightning protection system provides a means by which the energy may enter earth without passing through and damaging parts of a structure. A lightning protection system does not prevent lightning from striking; it provides a means for controlling it and preventing damage by providing a low resistance path for the discharge of energy to travel safely to ground. Improperly grounded connections are also a source of noise that can cause sensitive equipment to malfunction.

A good tower grounding system disperses most of the surge energy from a tower strike away from the building and equipment. The remaining energy on the RF cable shield and center conductor can be directed safely to ground by using a lightning arrester in series with the RF cable.

To limit the equipment damage due to a lightning strike, the following practices are recommended for the wireless system:

- Provide direct grounding from the antenna mounting bracket, the radio and antenna and the lightning arrestors to the same ground point at the base of the tower or a ground bus on the building. Use the grounding screws on the antenna bracket and the radio and antenna for terminating the ground wires.

- Install one RF lightning protector between the radio and antenna in series with the RF cable.
- A lightning arrestor in series with the RF cable at the point of entry to the building.
- Install a lightning arrestor in series with the IF cable at the transceiver on the tower/mast.
- The AC wall outlet ground for the terminal must be connected to the same grounding system as the radio and antenna lightning protectors.

GLOSSARY

A

AAS: Adaptive antenna system (see Introduction for further details)

AP: Access point

API: Application programmers interface

ATCA: Advanced telecommunications computing architecture

B

BE: Best effort scheduling service for requesting uplink bandwidth

BER: Bit error rate

BS: Base station

BWA: Broadband wireless access

C

CIR: Committed information rate used to specify the guaranteed data rate to the customer.

CPE: Customer premises equipment (interchangeable with ST)

D

DCD: Downlink channel descriptor

DFS: Dynamic frequency selection (see Introduction for further details)

DL: Downlink

DLFP: Downlink frame prefix

E

E1: ITU term for a 2Mb/s pulse code modulated transmission link

EIRP: Effective isotropic radiated power

F

FCH: Frame control header

FDD: Frequency division duplex

FEC: Forward error correction

FFT: Fast Fourier transform used to convert a signal from the time domain into the frequency domain

H

H-FDD: Half duplex FDD

I

IAD: Integrated access device

IP: Internet protocol

K

Kb/s: Kilobits per second

M

MAC: The next layer up from the PHY, known as the media access controller

Mb/s: Megabits per second

MIB: Management interface block

MIMO: Multiple-in, multiple-out

MIR: Maximum information rate used to specify the maximum data throughput to a customer.

MRC: Maximal-ratio combining

N

NLOS: None line of sight radio propagation path

NRTP: Non real time polling is similar to real time polling but is used to request uplink bandwidth less regularly

O

O&M: Operations and maintenance

ODU: Out door unit associated with a ST

OFDM: Orthogonal frequency division multiplexing

P

PHY: The physical layer associated with the WiMAX interconnection stack

PMP: Point to multipoint radio systems architecture

PoE: Point to point protocol over Ethernet

PtP: Point to point radio systems architecture

Q

QoS: Quality of service, which is used to specify level of data throughput

R

REC: Radio equipment controller

RTP: Real time polling allows a service flow to request uplink bandwidth at regular intervals

Rx: Receiver

S

SDMA: Space division multiple access is a technique which makes it possible to increase the capacity of a cellular mobile radio system by taking advantage of spatial separation between users

SDR: Software defined radio

SF: Service flow

SME: Small to medium sized enterprise

SNMP: Simple network management protocol

SNR: Signal to noise

SOFDMA: Scaleable orthogonal frequency division multiplexing

SoHo: Small office/home office

SS: Subscriber station (interchangeable with CPE or ST)

ST: Subscriber terminal (interchangeable with CPE or SS)

STC: Space time coding

T

T1: North American standard 1.56Mb/s pulse code modulated transmission link

TDD: Time division duplex

TDM: Time division multiplexing

Tx: Transmitter

U

UCD: Uplink channel descriptor

UGS: Unsolicited grant service used to provide fixed bandwidth slots on the uplink for an ST to transmit data at regular intervals. The bandwidth should be used by the UGS SF, however the final decision of which SF (if any) uses the bandwidth slot is made by the ST.

V

VoIP: Voice over Internet protocol

W

WiMAX: WiMAX is a wireless industry coalition whose members are organized to advance IEEE 802.16 standards for broadband wireless access (BWA) networks.



How to find out
more
about
Airspan products
and solutions

For more information about Airspan, its products and solutions, please visit our Web site:

www.airspan.com

Or write to us at one of the addresses below.

We will be delighted to send you additional information on any of our products and their applications around the world.

Airspan has offices in the following countries:

Europe

Czech Republic
Poland
Russia
United Kingdom

Africa

South Africa

Americas

United States

Asia Pacific

Australia
China
Indonesia
Japan
New Zealand



Worldwide Headquarters:
Airspan Networks Inc.
777 Yamato Road, Suite 105
Boca Raton, Florida 33431-4408
USA

Tel: +1 561 893 8670
Fax: +1 561 893 8671

Main Operations:
Airspan Communications Ltd.

Cambridge House, Oxford Road,
Uxbridge, Middlesex UB8 1UN
UK

Tel: +44 (0) 1895 467 100