



WLS 8060 MAX

Wireless Loudspeaker System



Bedienungsanleitung

User Instructions



Table of Contents

	Page
0. FCC Statement	10
1. Introduction	11
2. Safety	11
2.1. Precautions	11
2.2. Potential Risks	11
3. Unpacking	11
4. Description	11
4.1. General	11
4.2. Optional Accessories	11
4.3. Controls	11
5. Setting Up	13
5.1. Operating Environment	13
5.2. Audio Connections	13
5.3. Receiving Antennas	13
5.4. Powering Up (Battery Operation)	14
5.4.1. Total Discharge Protection Circuit	14
5.5. Powering Up (AC Operation)	14
6. Operating Notes	14
6.1. Wireless Microphone	14
6.1.1. WLS 8060 Placement	14
6.1.2. Selecting the Carrier Frequency	15
6.1.3. Powering Up the Transmitter	15
6.1.4. Using the Transmitter	15
6.1.5. Receiver	16
6.1.6. Replacing Handheld Transmitter Microphone Elements	16
6.1.7. Interference	16
6.2. Feedback	16
6.3. Proximity Filter	16
7. Cleaning	16
8. Specifications	17

0. FCC Statement

This equipment has been tested and found to comply with the limits for a Class B digital device, pursuant to Parts 74, 15, and 90 of the FCC Rules. These limits are designed to provide reasonable protection against harmful interference in a residential installation. This equipment generates, uses, and can radiate radio frequency energy and, if not installed and used in accordance with the instructions, may cause harmful interference to radio communications. However, there is no guarantee that interference will not occur in a particular installation. If this equipment does cause harmful interference to radio or television reception, which can be determined by turning the equipment off and on, the user is encouraged to try to correct the interference by one or more of the following measures:

- Reorient or relocate the receiving antenna.
- Increase the separation between the equipment and the receiver.
- Connect the equipment into an outlet on a circuit different from that to which the receiver is connected.
- Consult the dealer or an experienced radio/TV technician for help.

Shielded cables and I/O cords must be used for this equipment to comply with the relevant FCC regulations. Changes or modifications not expressly approved in writing by AKG Acoustics may void the user's authority to operate this equipment.

This device complies with Part 15 of the FCC Rules. Operation is subject to the following two conditions: (1) this device may not cause harmful interference, and (2) this device must accept any interference received, including interference that may cause undesired operation.

Please read this manual carefully before operating the equipment.

WLS 8060 "MAX"

1. Introduction

The WLS 8060 "MAX" is a high quality powered loudspeaker for a wide range of applications. It allows you to set up a mobile or fixed sound system quickly and easily. This professional design is easy to use even if you are not familiar with the intricacies of sound reinforcement. A clear control layout and rugged case make the WLS 8060 "MAX" a user-friendly tool for every sound system application.

2. Safety

2.1. Precautions

1. This device has been manufactured and tested in accordance with the German VDE safety guidelines for electronic equipment. It has left the factory in perfectly safe condition. In order to maintain safety and avoid risks of damage or injury, take the usual precautions and follow all safety instructions in the manual.
2. This device conforms to the German Class 1 safety standards. When properly installed, all exposed metal parts are permanently connected to safety ground. For safety reasons, connect the equipment to a standard three-pin outlet with protective ground only. Never open the safety ground connection.
3. This device conforms to the EMC legislation currently in force as certified by the CE mark on the device.
4. This device contains no user serviceable parts. To reduce the risk of fire or electric shock, do not open the device and refer servicing to qualified personnel.
5. Make sure to dispose of used batteries conforming to local waste disposal rules. Never throw batteries into the fire (risk of explosion).

2.2. Potential Risks

If the equipment

- is visibly damaged;
- contains loose parts;
- does not operate correctly;
- has been stored under adverse conditions (e.g., outdoors or in a damp room) for extended periods of time; or
- was exposed to high transportation stress (e.g., due to inadequate packaging),

operating the equipment may be unsafe. Switch power to the equipment off and mark the equipment.

Make sure the equipment cannot be connected to power or switched on unintentionally by third persons.

3. Unpacking

Your WLS 8060 "MAX" comprises the following components:

- 1 **WLS 8060 powered loudspeaker**
- 1 **HT 80 handheld transmitter with D 880 WL1 microphone element** or **PT 80 bodypack transmitter** (without microphone)

- 1 **AC adapter**
- 1 **CB 6060 carrying case**
- 2 **receiving antennas**

Please check that the package contains all components of the system you ordered. If anything is missing, please contact your AKG dealer immediately.

4. Description

4.1. General

The WLS 8060 is a powered loudspeaker with an rms power of 40 W. A built-in mixer with 2-band equalizer lets you connect a CD player or similar audio source, one wired microphone, and the supplied wireless microphone for simultaneous operation.

The integrated WMS 80 Series receiver provides highly reliable reception and excellent sound quality. The supplied handheld transmitter with microphone element or bodypack transmitter makes the WLS 8060 "MAX" a complete sound system for wired or wireless operation.

For mains independent operation, the WLS 8060 features a built-in high quality, leakproof lead gel rechargeable battery that conforms to the strict standards of the German Association of Casualty Insurers.

The battery features much lower self-discharge and a better capacity/volume ratio than nickel-cadmium batteries and has no memory effect. Its capacity is 7.2 Ah.

4.2. Optional Accessories

WLS 8060:

- RP 6060 rain cover
- CB 6060 carrying case
- STWLS stand

HT 80:

- D 3700 WL1, D 3800 WL1, C 5900 WL1, C 535 WL1 microphone elements
- W 880 foam windscreen for D 880 WL1
- W 3001 foam windscreen for D 3700 WL1, D 3800 WL1, C 5900 WL1
- W 23 foam windscreen for C 535 WL1

PT 80:

- C 417 L, C 419 L, C 420 L, CK 77 L microphones
- MKG/L guitar cable for electric guitar or bass, or portable keyboards
- CB 60 carrying case

4.3. Controls

All controls, inputs, and outputs of the WLS 8060 are located on the loudspeaker enclosure rear panel. Refer to fig. 1 on the next page.

A sturdy carrying handle is integrated in the rear panel of the enclosure.



Abb. 1: Bedienelemente WLS 8060

WLS 8060 "MAX"

1. RECHARGE BATTERY

DC input jack for charging the integrated battery or operating the WLS 8060 on AC power using the supplied AC adapter.

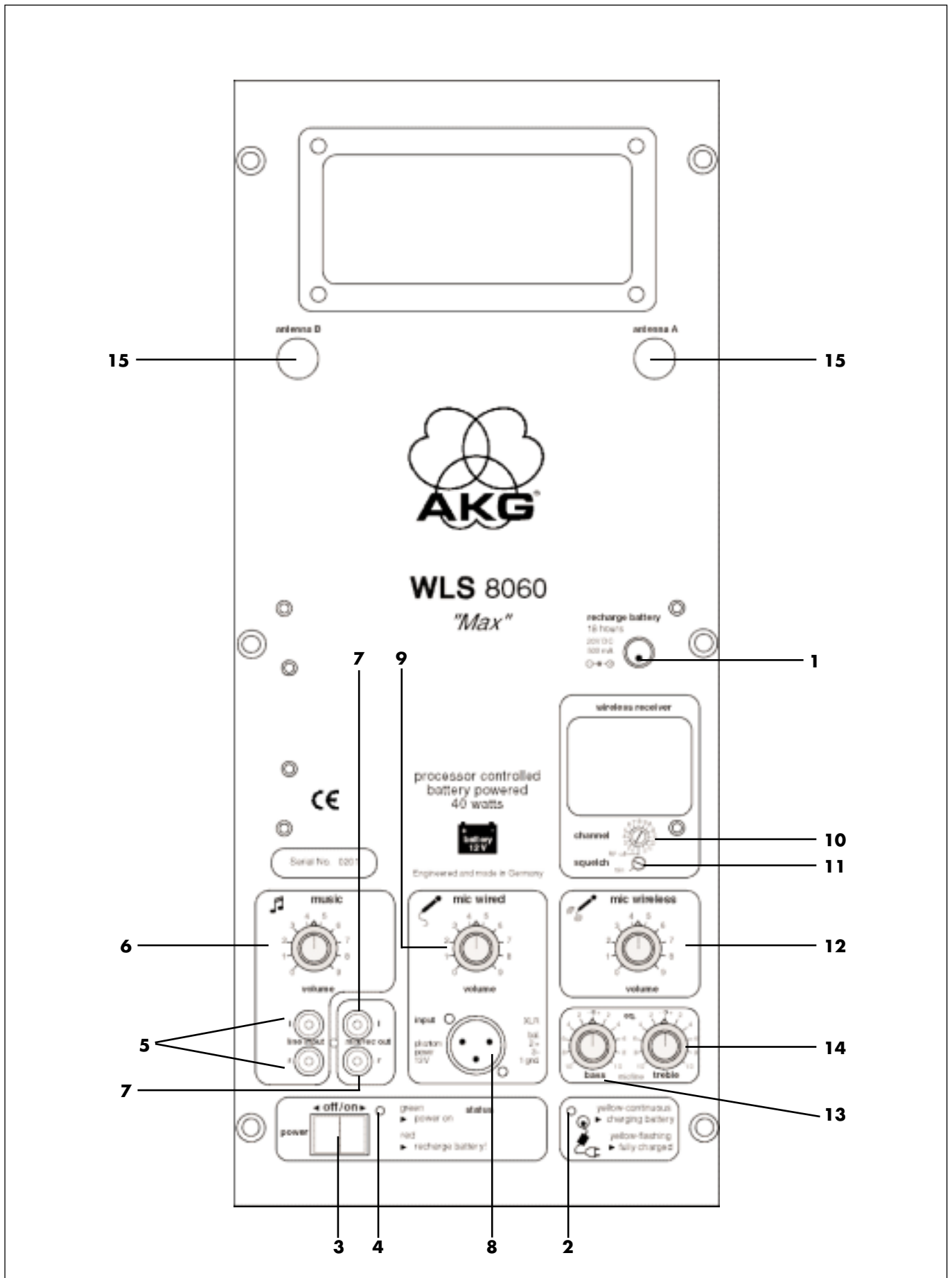
2. Charging LED

This yellow LED will light constantly while the battery is being charged and will start flashing as soon as the battery is fully charged.

3. POWER switch

Switches power to the WLS 8060 audio section and amplifier ON and OFF but does not affect the charging circuit.

4. STATUS LED

The STATUS LED will light green to indicate the unit is ON and the battery adequately charged. It will change to red when the battery is down.

MUSIC

5. LINE INPUT L/R

These two RCA jacks allow you to connect a CD player, cassette recorder, or other line level source to your WLS 8060 using a stereo RCA cable (not supplied). The stereo input signal is internally summed to mono. Input sensitivity is 100 mV into 10 k Ω for nominal level.

6. VOLUME

This rotary potentiometer sets the loudness volume of the audio source connected to the LINE INPUT L/R jacks (5).

7. LINE OUT L/R

These two RCA jacks allow you to connect either a recorder or another WLS 8060 to your unit using a stereo RCA cable (not supplied).

The two jacks are internally paralleled and carry the output signal of the built-in mixer with all the volume and EQ settings you made. The output voltage at nominal level is 0.5 V into 200 Ω source impedance.

WIRED MIC

8. INPUT

This balanced female XLR connector allows you to connect a wired microphone (optional) via a standard microphone cable with a male XLR connector (optional). Since the microphone INPUT provides 12 V phantom power you can connect both dynamic and electret or condenser microphones.

Input sensitivity for nominal level is 2 mV into 1 k Ω . Pin 1 is ground, pin 2 "hot" (inphase), pin 3 return.

9. VOLUME

This rotary potentiometer sets the loudness volume of the microphone connected to the INPUT connector (8).

WIRELESS RECEIVER

10. CHANNEL

This recessed rotary switch selects the carrier frequency of the built-in receiver for the supplied handheld or bodypack transmitter.

11. SQUELCH

This recessed rotary control sets the threshold of the squelch circuit integrated in the receiver for suppressing unwanted noise. (For details refer to section 6.1.5. Receiver.)

WIRELESS MIC

12. VOLUME

This rotary potentiometer sets the loudness volume of the wireless microphone.

EQ

The effective two-band equalizer is located in the signal path immediately ahead of the power amplifier and therefore acts on both the two microphone inputs and the LINE input.

13. BASS

Rotary control for cutting or boosting the low frequencies.

14. TREBLE

Rotary control for cutting or boosting the high frequencies.

Antenna Sockets (15)

Two BNC sockets for connecting the supplied receiving antennas.

5. Setting Up

5.1. Operating Environment

1. Acceptable ambient temperature during operation ranges from -5°C to +40°C.
2. Acceptable temperature during storage or shipping ranges from -15°C to +40°C.
3. If condensation has formed on the equipment or the rear panel during shipping or storage, allow the unit to acclimate for 2 hours before powering up.
4. The loudspeaker has been designed for use in a dry environment with air of normal relative humidity and dust concentration. Never expose the unit to aggressive chemical liquids or vapors.
5. You can position the unit at any angle. Make sure, though, to provide at least 2 inches of free air space behind the rear panel for adequate ventilation.
6. Do not expose the WLS 8060 to temperatures below -15°C as this would cause the acid contained in the battery to freeze and damage the battery.

5.2. Audio Connections

1. Set all VOLUME controls (6), (9), and (12) to zero.
2. Connect the desired audio source (e.g., cassette player, CD player) to the LINE INPUT jacks (5) using a stereo RCA cable.
3. Use a commercial XLR cable to connect your wired microphone to the INPUT connector (8).
4. If you want to record your performance or presentation, connect a (cassette, DAT, tape, or other) recorder to the LINE OUT jacks (7) using a stereo RCA cable.
5. For consistent audience coverage, you can use another WLS 8060. Connect the LINE OUT jacks (7) to the LINE IN jacks (5) of the other WLS 8060 using a stereo RCA cable.

5.3. Receiving Antennas

1. Plug the two supplied receiving antennas into the two rear panel antenna sockets (15).



2. Tighten the fixing nut on each antenna CW.
3. Point both antennas upward so that the two antennas will form a "V".
If you cover the WLS 8060 with the optional RP 6060 rain cover point the antennas straight down.

5.4. Powering Up (Battery Operation)

The WLS 8060 has been designed primarily for battery operation.

Before first operating the WLS 8060 or if the unit has not been connected to AC power for more than a year, **charge the battery for 18 hours.**

1. Plug the DC cable on the supplied AC adapter into the RECHARGE BATTERY jack (1) on the WLS 8060 rear panel (see fig. 1).
2. **Check that the AC mains voltage stated on the supplied AC adapter is identical to the AC mains voltage available where you will use your WLS 8060.** Using the AC adapter with a different AC voltage may cause irreparable damage to the unit.
3. Connect the AC cable on the AC adapter to a convenient power outlet. Do not use switched outlets!
Charging will start automatically and the yellow Charging LED (2) will light constantly.
When the yellow Charging LED (2) starts flashing the battery is fully charged and the WLS 8060 is ready to operate.
4. Unplug the DC cable of the AC adapter from the RECHARGE BATTERY jack (1).
5. To power up the WLS 8060 set the POWER switch (3) to ON.
The STATUS LED (4) next to the POWER switch (3) will illuminate green.
If the STATUS LED (4) lights red the battery is down. The electronic circuitry and the loudspeakers will switch off automatically. Recharge the battery as per steps 1 through 4.

Note: Depending on the load, battery operating time will be 10 to 14 hours.

Since the battery has no memory effect, you will not need to discharge it fully before charging. Therefore, you can start charging at any time irrespective of the battery's residual capacity.

Important: Lead batteries should not be stored for extended periods of time in entirely or partially discharged condition. We therefore recommend to recharge the battery immediately after use.

In order to make sure the WLS 8060 is always ready to operate, it is best to leave it connected to AC power whenever you do not use it.

5.4.1. Total Discharge Protection Circuit

Discharging a battery totally may cause extensive damage. We therefore provided the electronic circuitry of the WLS 8060 with an intelligent protection circuit that effectively prevents the battery from being totally discharged. The protection circuit automatically isolates the entire WLS 8060 electronics from the battery and switches the loudspeakers off before battery capacity approaches

the total discharge threshold. If this happens, recharge the battery immediately.

5.5. Powering Up (AC Operation)

The WLS 8060 has been designed for an AC voltage of 230 V/50 Hz. Custom versions with an adapter for other AC voltages are available on request.

1. Plug the DC cable on the supplied AC adapter into the RECHARGE BATTERY jack (1) on the WLS 8060 rear panel (see fig. 1).
2. **Check that the AC mains voltage stated on the supplied AC adapter is identical to the AC mains voltage available where you will use your WLS 8060.** Using the AC adapter with a different AC voltage may cause irreparable damage to the unit.
3. Connect the AC cable on the AC adapter to a convenient power outlet.

Important: In case the AC plug needs to be replaced with a different type, note that this job may only be performed by a qualified technician.

4. To power up the WLS 8060 set the POWER switch (3) to ON.
The STATUS LED (4) next to the POWER switch (3) will illuminate green.

Note: During AC operation, the charging circuit of the WLS 8060 will automatically switch to trickle charge mode. This means that the battery will be automatically recharged during operation. This also means you can continue operating the WLS 8060 on AC power even if the battery is completely down.

Note: In the event of a power failure, the WLS 8060 will automatically switch to battery operation with no interruption. Therefore you can not switch the WLS 8060 on and off by means of an external power switch or safety cut-out.

6. Operating Notes

6.1. Wireless Microphone

In order to prevent unnecessary noise, tune the transmitter and receiver to the same carrier frequency **prior to powering up** and inserting batteries.

6.1.1. WLS 8060 Placement

Reflections off metal parts, walls, ceilings, etc. or the shadow effects of musicians or other people may weaken or cancel the direct transmitter signal.

For best results, place the WLS 8060 as follows:

1. Place the WLS 8060 near the performance area (stage). Make sure, though, that the transmitter will never get any closer to the receiver than 10 ft (3 m). Optimum separation is 16 ft. (5 m).
2. There should always be a direct line of sight between the transmitter and receiver.
3. Place the WLS 8060 at least 5 ft. (1.5 m) away from any big metal objects, walls, scaffolding, ceilings, etc.

WLS 8060 "MAX"

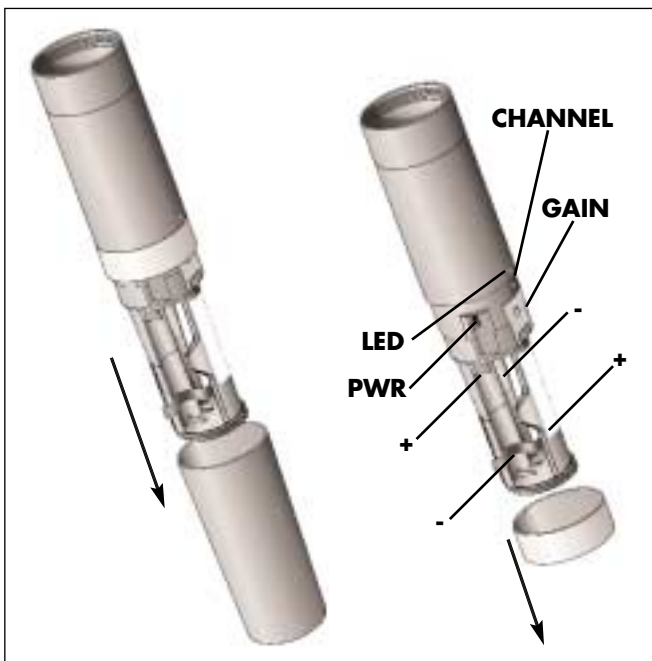

Fig. 2: Opening the handheld transmitter

6.1.2. Selecting the Carrier Frequency

- Handheld Transmitter:** Unscrew the battery compartment cover and the color code ring CCW.
Bodypack transmitter: Referring to fig. 3, open the battery compartment (3h).
All controls are now accessible.
- Use a small screwdriver to set the CHANNEL selector on the handheld transmitter or on the bodypack transmitter (3f) to the desired channel.
- Set the CHANNEL selector (10) on the WLS 8060 to the same channel as the transmitter.

Important Note: If you set the CHANNEL selector on the transmitter to "0", the status LED on the transmitter will start flashing. This means that no signal is being transmitted.

6.1.3. Powering Up the Transmitter

- Open the battery compartment referring to fig. 2 for the handheld transmitter and fig. 3 for the bodypack transmitter. Make sure that the end of the ribbon fixed inside the battery compartment of the handheld transmitter will stick out of the battery compartment. (The ribbon is needed for removing the batteries.)
- Insert the supplied batteries into the battery compartment conforming to the polarity marks.
The transmitter will not function with the batteries inserted incorrectly.
- Powering up the handheld transmitter:** Set the PWR switch to "1".
- Powering up the bodypack transmitter:** Connect your microphone - or instrument with MKG/L guitar cable (optional) - to the mini XLR socket (3d). Rotate the security cover (3m) CW to uncover the switches and set the POWER switch (3a) to "1".
- Handheld and bodypack transmitters:** The status LED will flash momentarily. If the batteries are in good condition, the status LED will continue glowing dimly. When the status LED illuminates brightly the batteries will be

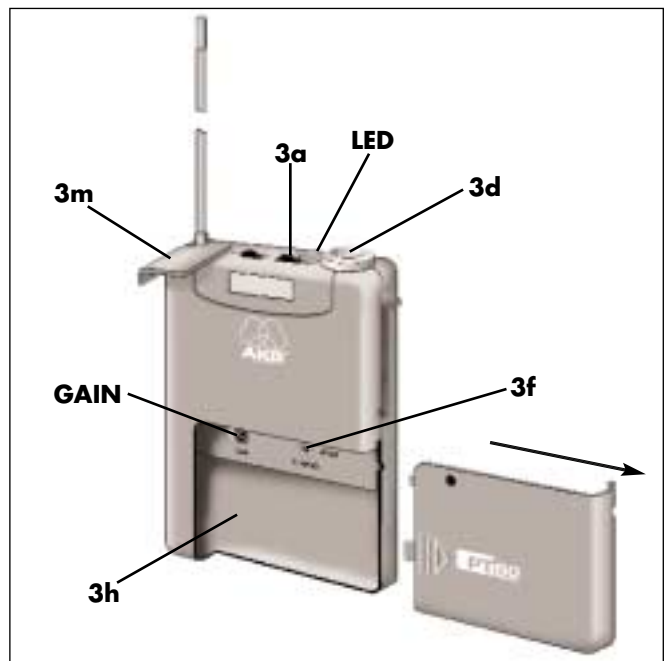

Fig. 3: Bodypack transmitter

dead within about 90 minutes. Replace the batteries with new ones as soon as possible.

If the status LED fails to illuminate the batteries are dead. Insert new batteries.

- Handheld transmitter:** Slide the supplied adjustable protective ring onto the shaft and screw the battery compartment cover back on. You can rotate the protective ring so that only the desired control will be accessible and all others covered.
Bodypack transmitter: Replace the battery compartment cover.

6.1.4. Using the Transmitter

Handheld Transmitter

- Hold the microphone perpendicularly and so that its front grille will be about 1 to 2 inches (2 to 5 cm) away from your mouth.
- Talk across and slightly above the microphone front grille. This is the best way to avoid pop noises (overemphasis of plosive sounds such as "p" and "t").
- When talking outdoors, we recommend to slip an external windscreen onto the microphone (see section 4.2. Optional Accessories).
- Never cover the antenna with your hand. This would weaken the transmittee signal.

Bodypack Transmitter

For instructions on how to use the microphone, refer to the manual for your microphone.

Setting Gain

The procedure for setting gain is the same for the handheld and bodypack transmitters. Refer to figs. 2 and 3 above.

- Using a small screwdriver, set the GAIN control so that the red status LED on the transmitter will only flash on the loudest signal peaks.



2. The red status LED on the transmitter lighting brightly means the transmitter is overloaded. Turn the GAIN control on the transmitter CCW to the point that the status LEDs will only flash occasionally.

MIC Switch

Both the handheld and bodypack transmitters provide a MIC switch.

In order to mute the microphone, set the MIC switch to "0". Power and carrier frequency remain ON, however. Thus, no noise will become audible if you mute the microphone even if the SQUELCH control (11) on the WLS 8060 is set to minimum (fully CCW).

6.1.5. Receiver

SQUELCH Control

The squelch circuit switches the receiver off if the received signal is too weak, in order to suppress the related noise or the residual noise of the receiver while the transmitter is off.

1. Set the SQUELCH control (11) to minimum before first switching the WLS 8060 on (see fig. 1).
2. If unwanted noise becomes audible, turn the SQUELCH control (11) CW just enough to suppress the noise.

Important: Never set the squelch threshold higher than absolutely necessary. The higher the squelch threshold, the lower the sensitivity of the receiver and thus the usable range between transmitter and receiver.

VOLUME Control

Use the VOLUME control (12) to set the desired loudness volume for the wireless microphone.

Important: In battery operation, whenever you do not use the wireless microphone, set the VOLUME control (12) to zero and the CHANNEL selector (10) to "OFF" in order not to discharge the battery prematurely.

6.1.6. Replacing Handheld Transmitter Microphone Elements

You can replace the D 880 WL1 microphone element mounted on the HT 80 handheld transmitter with any WMS 80 Series microphone element (D 3700 WL1, D 3800 WL1, C 5900 WL1, C 535 WL1):

1. Unscrew the microphone element CCW.
2. Screw the new microphone element CW onto the thread on the transmitter.
All electrical connections will be made automatically.

6.1.7. Interference

Sometimes you can eliminate interference noise by shortening the receiving antennas one segment at a time to the point that the noise disappears.

If this does not help, set both the transmitter and receiver to a different carrier frequency using the CHANNEL selectors.

6.2. Feedback

When using your WLS 8060 with a wired or wireless microphone, acoustic feedback may occur so the loudspeaker would start whistling or howling. To prevent feedback,

1. Make sure never to point the microphone element directly at the loudspeaker.
2. Hold the handheld transmitter by the shaft. Be sure not to cover the microphone element with your hand.
3. Should the loudspeaker start whistling or howling all the same turn the VOLUME control (9) or (12) down CCW to the point that the feedback noise will stop.

6.3. Proximity Filter

When you talk into a microphone from a distance of less than two inches (5 cm), the low frequencies will be strongly emphasized. This so-called "proximity effect" reduces intelligibility. The bass boost is higher in dynamic microphones than in condenser types. The WLS 8060 features a proximity filter that automatically compensates for proximity effect and ensures clear, well balanced speech reproduction even if you touch the microphone with your lips.

7. Cleaning

You can clean the loudspeaker enclosure with a moistened cloth. To clean the transmitter surfaces, use a soft cloth moistened with methylated spirits or alcohol.

WLS 8060 "MAX"

8. Specifications

WLS 8060

Amplifier power (rms/peak)	40 W/60 W
Drivers	1 x 8" and 1 annular driver
Speaker type	2-way bass reflex
Crossover frequency	4 kHz, 12/18 dB/octave
Sensitivity at 1W/1m	96 dB
Max. sound pressure level	125 dB
Audio frequency response	65 Hz to 20 kHz (-6dB)
Projection angle (H x V)	80° x 80°
Mixer inputs	Wired microphone: 1 k Ω balanced Wireless microphone: internal, 10 k Ω 2 x LINE: 10 k Ω unbalanced
Phantom power	12 V
Outputs	2 x LINE, +12 dB into 600 Ω for recording or second WLS 8060
Connectors	Wired microphone input: 3-pin XLR LINE inputs: RCA jacks (stereo summed to mono) LINE outputs: RCA jacks Antenna inputs: 2 x BNC
Squelch threshold	-75 to -70 dBm
Equalizer	Bass/treble
Processor functions	Automatic proximity filter Limiter with autosubsonic filter
Dimensions (W x H x D)	Approx. 240 x 500 x 270 mm (9.4 x 19.7 x 10.6 in.)
Weight	Approx. 7 kg (15 lbs.) inclusive of battery and receiver
AC adapter/charger	230 VAC/24 VDC, 0.5 A
Rechargeable battery	12 V, 7.2 Ah
Battery life (speech/ music)	Approx. 10 to 14 hours

Transmitter	HT 80 + D 880 W1	PT 80
Carrier frequencies	710.2 to 860.9 MHz	
Modulation	FM	
Audio bandwidth	50 to 20,000 Hz	
Polar pattern	Hypercardioid	-
Frequency stability	± 10 ppm (-10°C to +50°C)	
Rated deviation	30 kHz (US1a, US1b: 7.5 kHz)	
Distortion at 1 kHz	<0.8%	<0.5%
Compander	Yes	
Signal/noise	50 dB(A) typical	
Limiter	Yes	
RF output	10 mW	
Current consumption	130 mA typical	145 mA
Power requirement	2 x 1.5 V AA size batteries	
Battery life	>10 hours	>8 hours
Input sensitivity	-95 dBm typical	-
Audio input level for rated deviation	350 mV/1 kHz	1400 mV/1 kHz
Input impedance	220 k Ω	
Condenser microphone power supply	-	6 V/6.8 k Ω on pin 3
Dimensions (W x D x H)	240 x 36 mm dia. (9.4 x 1.4 in.)	92 x 65 x 20 mm (3.6 x 2.6 x 0.8 in.)
Net weight	245 g (8.6 oz.)	76 g (2.7 oz.)



WLS 8060 "MAX"

Notizen * Notes

Mikrofone · Kopfhörer · Drahtlosmikrofone · Drahtloskopfhörer · Kopfsprechgarnituren · Akustische Komponenten
Microphones · Headphones · Wireless Microphones · Wireless Headphones · Headsets · Electroacoustical Components

Technische Änderungen vorbehalten. Specifications subject to change without notice.



H A Harman International Company

AKG Acoustics GmbH

Lemböckgasse 21-25, P.O.B. 158, A-1230 Vienna/AUSTRIA
Tel: (43 1) 86 654-0*, Fax: (43 1) 86 654-516
Internet: <http://www.akg-acoustics.com>

AKG Acoustics, Harman Pro GmbH

Bodenseestraße 228, D-81243 München/GERMANY
Tel: (089) 87 16-0, Fax: (089) 87 16-200
e-mail: akg-akoustics@t-online.de

Arbiter Pro Audio

Wilberforce Road, London NW9 6AX/ENGLAND
Tel: (0181) 202 1199, Fax: (0181) 202 7076

AKG ACOUSTICS, U.S.

1449 Donelson Pike, Nashville, TN 37217, U.S.A.
Tel: (615) 360-0499, Fax: (615) 360-0275

Studer Japan Ltd.

2-43-7, Uehara, Shibuya-ku, Tokyo 151-0064/JAPAN
Tel: (813) 3465-2211, Fax: (813) 3465-2214

Erikson Pro Audio

620 McCaffrey, St-Laurent, Quebec, H4T 1N1, CANADA
Tel: (514) 738-3000, Fax: (514) 737-5069
Internet: www.jam-ind.com/eriksonpro