



# MODEL PG30 Pilfergard Door Alarm

## Installation Instructions

345 Bayview Avenue  
 Amityville, New York 11701  
 For Sales and Repairs 1-800-ALA-LOCK  
 For Technical Service 1-800-645-9440  
 or visit us at <http://tech.napcosecurity.com/>  
 (Note: Technical Service is for security professionals only)  
 Publicly traded on NASDAQ Symbol: NSSC  
 © ALARM LOCK 2015

WI739E 02/15

### DESCRIPTION

The PG30 is a keypad operated surface-mounted microprocessor-controlled door alarm. Three programmable security levels provide degrees of access to suit various applications, such as unattended fire stairways, airport security areas, delivery entrances, etc. The unit contains a Form-C relay as well as provisions for an external power supply and external reed-switch contacts.

The unit mounts on the door with a magnetic actuator on the frame, or, if external wiring is required, vice versa. Entering the Master Code will alternately arm and disarm the unit. A selectable Annunciator feature beeps to signal opening of the door while the unit is disarmed. Opening the door, removing the cover or attempting to defeat the unit with a second magnet when armed, will activate the alarm. The unit may be operated from outside the door with the addition of a model PG30KPD External Keypad (optional).

### SPECIFICATIONS

**Dimensions:** 9" x 2 1/2" x 2 3/8" (22.8cm x 6.3cm x 6.8cm) (LxWxD)

**Finish:** Metallic Silver (PG30MS); Metallic Bronze (PG30MB)

**Power Requirements:** 9-volt alkaline battery (supplied). (The PG30 may be used with Model PP100 (optional) or other power supply providing 9-12VDC at 500mA).

**Battery Life:** Continuous Alarm, 3 hours; 2-Minute Shutdown, see Table 1 below.

Alarms / Year	Battery Life (Months)
1	17.6
2	17.4
3	17.1
4	16.8
5	16.6
6	16.3
7	16.1
8	15.8
9	15.6
10	15.4

Table 1. Battery Life with 2-Minute Shutdown option.

**Sounding Device:** Piezo electronic sounder, sweep siren, 110dB at 10 feet.

**Shipping Weight:** 1lb., 10oz.

### FEATURES

- Three codes: Master, Management and Passage
- Three levels of security to suit different applications
- Three alarm types: Sweep, steady or pulsing siren
- Two Annunciator volume levels
- Automatic low-battery detection

- Provisions for external power supply
- Provisions for external reed-switch contacts for multiple-door monitoring
- Built-in Form-C relay for connection to control panel or other device

### INSTALLATION

**Note:** In many applications, the need for a template may be eliminated by using the Magnet Alignment procedure in step 10. If outside keypad control or remote wiring is required, however, the template must be used.

1. If using a template, select the proper template for the type of door. (If not using a template, proceed to step 6).
2. Mark and drill 9/64" holes per template directions on the door and jamb. (Four holes for base plate and two holes for magnetic actuator). **Note:** Certain narrow-stile doors require only two holes for mounting plate.
3. Mark and drill 3/8" hole per template for remote wiring to a control panel.
4. **For outside keypad control only:** Drill 3/4" hole as shown on template. Refer to the PG30KPD instructions for installation of outside keypad.
5. Knock out the necessary holes from the base plate and install on the door with #8 sheet-metal screws (supplied). If an outside keypad is used, ensure that its cable is routed through the hole in the base plate.
6. Connect the battery (a chirp will sound; this chirp will confirm that power is connected properly). **Important:** Press the small **CLEAR** button at the lower-left corner of the circuit board (see Fig. 1).
7. Remove the jumper **ONLY** on the side of the unit that the magnet will **NOT** be installed.
8. Select jumper options (J1 - J4) as follows: Refer to Fig. 1; the unit is factory supplied with the Annunciator option enabled (J3 installed) and 2-Minute Shutdown alarm selected (J4 removed).

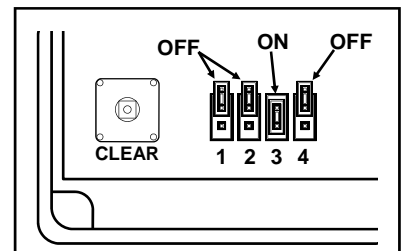

Fig 1. CLEAR Button and Jumpers

**Important:** Changes in the jumper configuration do not become effective until the unit is subsequently armed.

**J1: Entry Delay.** Alarm will sound 15 seconds after any unauthorized entry through door if unit is armed. This feature is used for authorized entry. To avoid an alarm upon entry, disarm unit within 15 seconds. To enable Entry Delay, install J1 across both pins.

**J2: Exit Delay.** Unit will be activated after 15 seconds each time unit is armed to allow authorized exit without an alarm. To enable Exit Delay, install J2 across both pins.

**J3: Annunciator.** Unit will sound for 2 seconds whenever the door is opened while disarmed. To disable the Annunciator, remove J3.

**J4: Continuous / 2-Minute Shutdown.** With J4 installed, an alarm will sound continuously until the battery is depleted. With J4 removed, the alarm will silence after two minutes and the unit will rearm (if the door is closed). The LED will start flashing to indicate that an alarm has occurred (Alarm Memory). Alarm Memory is cleared after about 4 hours or when the unit is re-armed. **Note:** If the door is still open after two minutes, the alarm will restart. **Note:** Jumper J4 is connected at the factory to only one pin of the 2-pin connector (off). To select Continuous alarm, remove J4 and reinstall it across both pins.

9. Install the cover onto the base plate. Secure the cover with #6-32 screws supplied. **Note:** The longest screw is the tamper screw. If not using a template, do not install the tamper screw until the magnet has been aligned and secured as follows.
10. (If unit has been installed using a template, proceed to step 11). After power-up, but before the tamper screw is installed, the unit will be in the Magnet Alignment Mode.
  - a. Place the magnet against the wall, adjacent to the bottom of the unit. Slowly slide the magnet upward. The LED will turn on, indicating closure of the reed switch, then the LED will turn off. Mark the doorjamb at the bottom of the magnet. (**Note:** Sliding the magnet still further will cause the LED to light again; ignore subsequent indications).
  - b. Similarly, place the magnet against the wall, adjacent to the top of the unit. Slowly slide the magnet downward. The LED will turn on, and then will turn off once again (see Note in step 10a). Mark the doorjamb at the top of the magnet.
11. Install the magnetic actuator so that it is centered between the two marks on the doorjamb. Use the two #8 sheet-metal screws supplied. **Note:** On steel frames, it is sometimes necessary to install a non-magnetic shim between the magnet and the frame to prevent the steel frame from absorbing the magnet's magnetic field, which could cause a constant or occasional false alarm condition. The shim should be 1/2" x 2 1/2" x 1/8" thick non-magnetic material (plastic, Bakelite, rubber, etc.).

### STANDBY MODE

After the magnet has been aligned and mounted, the tamper screw may be installed. This will place the unit in its standby mode (disarmed).

### ARMING & DISARMING

The unit is alternately armed and disarmed by entering the Master Code.

### WIRING

External wiring to the PG30 requires that the unit be mounted on the frame with the magnet on the adjacent door. (The PG30 may be mounted on a door with the addition of a Model 271 Flexible Cable). All wiring is made at its terminal strip. Wiring connections are summarized in the Wiring Diagram shown in Fig. 2.

**Relay (Terminals 1-3).** Terminal 1 = Normally Closed;

Terminal 2 = Common; Terminal 3 = Normally Open.

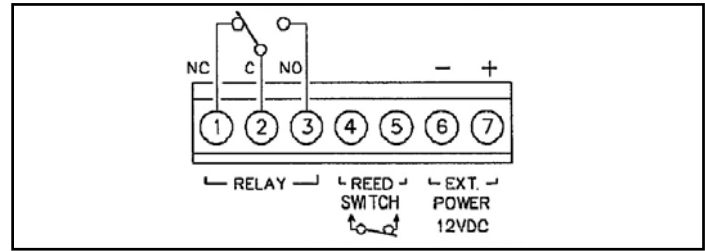

Fig. 2. Wiring Diagram. Also see Fig. 3

**Reed Switch (Terminals 4 & 5).** Connect external reed-switch contacts to Terminals 4 and 5 and remove both jumpers. **Note:** If reed switches are wired in series as shown in Fig. 3, several doors may be monitored simultaneously. Using #22AWG wire, maximum wiring distance should not exceed 50 feet (15.24m).

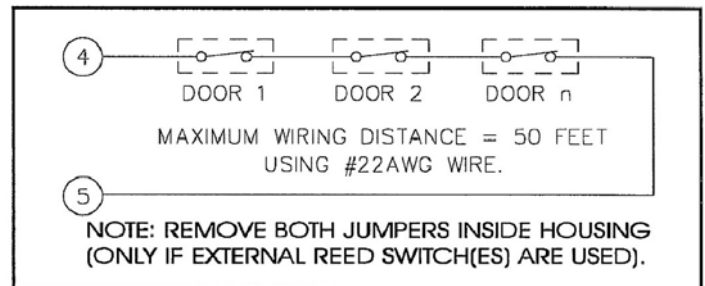

Fig. 3. Multiple door monitoring

**Power (Terminals 6 & 7).** Connect an external power supply: Positive (+) to Terminal 7; negative (-) to Terminal 6. Leave the internal battery in as a backup battery. If using the Alarm Lock PP100 Power Supply, connect the two battery clips to the unit and the internal battery as labeled.

### FIELD TEST

1. With the door closed, enter a valid arming code. A brief tone will sound indicating that the unit is armed (with or without delays, see options in **INSTALLATION:** step 8).
2. Open the door. A sweep siren alarm should sound.
3. On alarm, the relay will activate and remain latched for as long as the sounder is on. Relay contacts are rated at 125VAC/DC at 1/2A.
4. To reset the alarm, enter the Master Code or the Management Code.

### BATTERY REPLACEMENT

Whether armed or disarmed, the LED will blink about once every 4 hours when checking battery status. When the battery becomes weak, the unit will chirp and the LED will flash about once per minute, indicating the need for replacement. *Disarm the unit before replacing battery.* **When battery is disconnected, DO NOT press buttons or programming WILL BE LOST; connect new battery as quickly as possible.** Be sure the extra long Tamper Screw (see Fig. 4) is returned to its correct location (lower left corner); *failure to replace the Tamper Screw in its correct location will render the unit inoperable.*

### PROGRAMMABLE FEATURES

The following features are software programmable.

- Codes: Master, Management, and Passage Codes;
- Security Level (Level 1, 2 or 3);
- Alarm Type: Sweep, Steady, or Pulsing Siren; and
- Annunciator Volume: Low or High.

We recommend the unit be programmed after it has been mounted and the door closed, as the tamper switch must be installed and the magnet properly positioned with respect to the active reed switch. If it is desired to pre-program the unit before mounting, keep the tamper switch closed (install tamper screw) and the reed switch closed (place magnet near switch) until programming is completed.

**Note:** (1) When entering codes or programming, each button must be pressed within 5 seconds of the last or the unit will time out. (2) Press the [AL] button to cancel a wrong code entry (prior to completion). (3) Seven beeps indicate that the programmed code has been accepted. (4) Five beeps indicate either a wrong code entry or a programming error. (5) Three unsuccessful attempts to enter a code will sound a loud 2-second alert.

## CODES

Each code may be 3 to 5 digits in length.

**Master Code.** The Master Code can be used to program any code or feature or to arm or disarm. The default Master Code is 1 2 3 4 5. *This default Master Code must be changed before any other code or function can be programmed.* To program a new Master Code, press [1] [2] [3] [4] [5] [AL] [1] [AL] [new Master Code] [AL].

**Note:** Be sure to enter the new Master Code carefully. If the wrong Code is entered and is unknown, press the **CLEAR** button on the circuit board to reset the unit and erase all codes, then start over. (Whenever the **CLEAR** button is pressed, all programmed Codes are erased and the Master Code defaults to 1 2 3 4 5).

To program the Management Code (see below), press the Master Code, then press [AL] [2] [AL] [new Management Code] [AL].

**Management Code.** The Management Code may be used to program the Passage Code, any feature, or to silence the alarm.

**Passage Code.** This code allows passage through the protected door without altering the arm/disarm status of the unit. If the unit is armed, the door must be closed within 15 seconds or the alarm will sound. The Passage Code may be used with any programmed security level.

To program the Passage Code, enter the Master Code or Management Code, then press [AL] [3] [AL] [new Passage Code] [AL].

## SECURITY LEVELS

There are three levels of security to accommodate different applications. **Note:** The tamper switch and keypad are disabled until the door is closed. Security levels are programmable using the Master Code or Management Code:

**Level 1.** Provides the highest level of security and is the default mode of operation. Opening the door while armed will cause the alarm to latch on (after the entry delay, if enabled). The alarm may only be reset using the Master Code or the Management Code. To re-program Level-1 security (if changed), enter the Master Code or Management Code, then press [AL] [3] [3] [AL].

**Level 2.** Entering the Passage Code will allow the door to

be opened up to 15 seconds without activating an alarm. If no code is entered or if the door remains open longer than 15 seconds, a non-latching alarm will sound; that is, when the door is closed, the alarm will shut down and the unit will reset. Applications include unattended doors as may be found at fire stairwells, airport high-security areas, etc. that must remain closed after passage. To enable Level-2 security, first enter the Master Code or Management Code, then press [AL] [4] [4] [AL].

**Level 3.** Entering the Passage Code allows the door to remain open indefinitely without activating an alarm. When the door is closed, the unit will rearm automatically. A typical application might be a delivery entrance where the door is propped open for long periods of time. To enable Level-3 security, first enter the Master Code or Management Code, then press [AL] [5] [5] [AL].

## ALARM TYPES

**Sweep Siren.** This is the default alarm. To re-program a Sweep Siren alarm (if changed), enter the Master Code or Management Code, then press [AL] [1] [1] [AL].

**Steady Siren.** To program a Steady Siren alarm, enter the Master Code or Management Code, then press [AL] [1] [2] [AL].

**Pulsing Siren.** To program a Pulsing Siren alarm, enter the Master Code or Management Code, then press [AL] [1] [3] [AL].

## ANNUNCIATOR VOLUME

**Low.** This is the default setting. Low volume is adjustable by means of the potentiometer at the upper-left corner of the circuit board; clockwise rotation increases loudness. To reprogram Low-volume annunciator (if changed), press the Master Code or Management Code, then press [AL] [1] [4] [AL].

**High.** This setting provides maximum loudness. To program High volume, press the Master Code or Management Code, then press [AL] [1] [5] [AL].

## EXPLODED VIEW

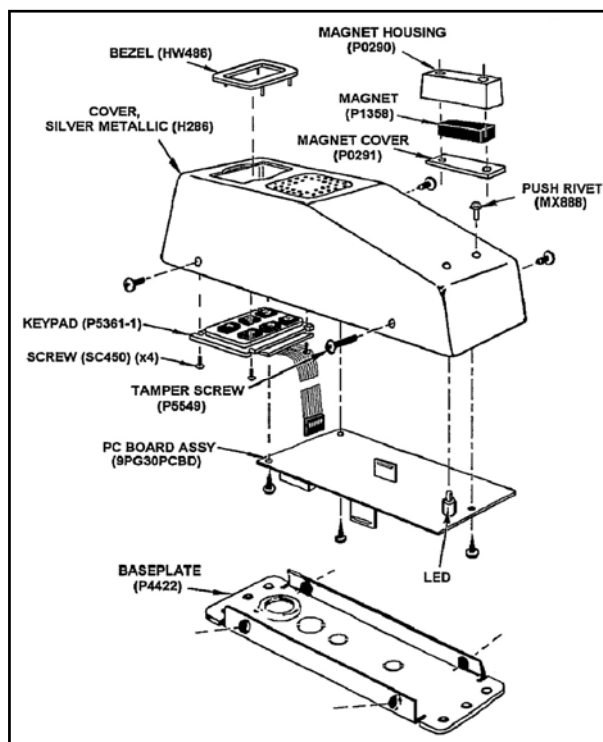

Fig. 4. Exploded view with part numbers

# ALARM LOCK LIMITED WARRANTY

ALARM LOCK SYSTEMS, INC. (ALARM LOCK) warrants its products to be free from manufacturing defects in materials and workmanship for twenty four months following the date of manufacture. ALARM LOCK will, within said period, at its option, repair or replace any product failing to operate correctly without charge to the original purchaser or user.

This warranty shall not apply to any equipment, or any part thereof, which has been repaired by others, improperly installed, improperly used, abused, altered, damaged, subjected to acts of God, or on which any serial numbers have been altered, defaced or removed. Seller will not be responsible for any dismantling or reinstallation charges, environmental wear and tear, normal maintenance expenses, or shipping and freight expenses required to return products to ALARM LOCK. Additionally, this warranty shall not cover scratches, abrasions or deterioration due to the use of paints, solvents or other chemicals.

THERE ARE NO WARRANTIES, EXPRESS OR IMPLIED, WHICH EXTEND BEYOND THE DESCRIPTION ON THE FACE HEREOF. THERE IS NO EXPRESS OR IMPLIED WARRANTY OF MERCHANTABILITY OR A WARRANTY OF FITNESS FOR A PARTICULAR PURPOSE. ADDITIONALLY, THIS WARRANTY IS IN LIEU OF ALL OTHER OBLIGATIONS OR LIABILITIES ON THE PART OF ALARM LOCK.

Any action for breach of warranty, including but not limited to any implied warranty of merchantability, must be brought within the six months following the end of the warranty period.

IN NO CASE SHALL ALARM LOCK BE LIABLE TO ANYONE FOR ANY CONSEQUENTIAL OR INCIDENTAL DAMAGES FOR BREACH OF THIS OR ANY OTHER WARRANTY, EXPRESS OR IMPLIED, EVEN IF THE LOSS OR DAMAGE IS CAUSED BY THE SELLER'S OWN NEGLIGENCE OR FAULT.

In case of defect, contact the security professional who installed and maintains your security system. In order to exercise the warranty, the product must be returned by the security professional, shipping costs prepaid and insured to ALARM LOCK. After repair or replacement, ALARM LOCK assumes the cost of returning products under warranty. ALARM LOCK shall have no obligation under this warranty, or otherwise, if the product has been repaired by others, improperly installed, improperly used, abused, altered, damaged, subjected to accident, nuisance, flood, fire or acts of God, or on which any serial numbers have been altered, defaced or removed. ALARM LOCK will not be responsible for any dismantling, reassembly or reinstallation charges, environmental wear and tear, normal maintenance expenses, or shipping and freight expenses required to return products to ALARM LOCK. Additionally, this warranty shall not cover scratches, abrasions or deterioration due to the use of paints, solvents or other chemicals.

This warranty contains the entire warranty. It is the sole warranty and any prior agreements or representations, whether oral or written, are either merged herein or are expressly cancelled. ALARM LOCK neither assumes, nor authorizes any other person purporting to act on its behalf to modify, to change, or to assume for it, any other warranty or liability concerning its products.

In no event shall ALARM LOCK be liable for an amount in excess of ALARM LOCK's original selling price of the product, for any loss or damage, whether direct, indirect, incidental, consequential, or otherwise arising out of any failure of the product. Seller's warranty, as hereinabove set forth, shall not be enlarged, diminished or affected by and no obligation or liability shall arise or grow out of Seller's rendering of technical advice or service in connection with Buyer's order of the goods furnished hereunder.

ALARM LOCK RECOMMENDS THAT THE ENTIRE SYSTEM BE COMPLETELY TESTED WEEKLY.

**Warning:** Despite frequent testing, and due to, but not limited to, any or all of the following; criminal tampering, electrical or communications disruption, it is possible for the system to fail to perform as expected. ALARM LOCK does not represent that the product/system may not be compromised or circumvented; or that the product or system will prevent any personal injury or property loss by burglary, robbery, fire or otherwise; nor that the product or system will in all cases provide adequate warning or protection. A properly installed and maintained alarm may only reduce risk of burglary, robbery, fire or otherwise but it is not insurance or a guarantee that these events will not occur. CONSEQUENTLY, SELLER SHALL HAVE NO LIABILITY FOR ANY PERSONAL INJURY, PROPERTY DAMAGE, OR OTHER LOSS BASED ON A CLAIM THE PRODUCT FAILED TO GIVE WARNING. Therefore, the installer should in turn advise the consumer to take any and all precautions for his or her safety including, but not limited to, fleeing the premises and calling police or fire department, in order to mitigate the possibilities of harm and/or damage.

ALARM LOCK is not an insurer of either the property or safety of the user's family or employees, and limits its liability for any loss or damage including incidental or consequential damages to ALARM LOCK's original selling price of the product regardless of the cause of such loss or damage.

Some states do not allow limitations on how long an implied warranty lasts or do not allow the exclusion or limitation of incidental or consequential damages, or differentiate in their treatment of limitations of liability for ordinary or gross negligence, so the above limitations or exclusions may not apply to you. This Warranty gives you specific legal rights and you may also have other rights which vary from state to state.