



# MDR-8000

## Microwave Digital Radios Users Manual

Alcatel Part Number 3EM11931AA  
Issue 9, December, 2007

3400 West Plano Parkway  
Plano, Texas 75075-5813 U.S.A.



# NORTH AMERICA CUSTOMER SERVICE CENTER

## 24 HOURS PER DAY, 7 DAYS PER WEEK

PHONE the Call Center at  
888-252-2832 (US and Canada)  
or  
613-784-6100 (International)

The Call Center Agent (CSA)  
Will help connect you with Technical Assistance (TAC)  
Or assist you with a Repair and Return

### **TAC**

- Phone-based technical support
- After-hour emergencies
- On-site technical support
- E-mail support [ml-tac.support@alcatel-lucent.com](mailto:ml-tac.support@alcatel-lucent.com)
- Software and hardware upgrades

### **Repair and Return**

- Module repair

### **Other Services Offered**

- **Training** <http://www.alcatel-lucent.com>support>
  - Technical Training
- **Field Services**
  - Installation and test
- Registration <http://www.alcatel-lucent.com>MyAccess>
  - Once registered
    - From "MyAlcatel" go to "Alcatel Support Documentation"
    - Register for access to Documentation and e-mail Update notifications  
For Product Change Notices (PCN), Product Documentations, etc.
  - Software and Hardware upgrade documentation
- **Customized and Comprehensive Service Agreements**

**ALCATEL-LUCENT'S PRIMARY MISSION IS  
SATISFYING OUR CUSTOMERS' QUALITY EXPECTATIONS.**

# TAC

## Technical Assistance Center

### Telephone Assistance, Normal Working Hours (CST 8am 5pm M-F)

TAC supports all Alcatel North America Microwave products. This includes routine questions and emergency service.

### Telephone Assistance, Emergency After-Hours

- Defined as loss of traffic, standby equipment, or network visibility on traffic-bearing systems.
- Available through our Customer Service Agents (CSA).

**Contact Information** Ask the Customer Service Agent (CSA) for a Microwave (MW) or a Network Management Service engineer (NMS).



**Alcatel-Lucent Wireless Transmission Div**  
**Customer Technical Assistance Center (CTAC)**

Contact via N America Call Center  
**Phone: 888-252-2832 or 613-784-6100**

Direct to WTD TAC Lab & Engineers  
**Email: [ml-tac.support@alcatel.com](mailto:ml-tac.support@alcatel.com)**  
**FAX: 972-477-7240**

Call us for assistance and/or information on your Alcatel Microwave Radios & Ancillary Equipment. We can assist with troubleshooting, maintenance, configuration, etc.

### Creating a TAC Action Request (AR)

Please provide the following information to the Customer Service Agent (CSA):

- Last and First name
- Company name
- Telephone number
- City and state (Street address if applicable) or Site Name and Location
- Equipment type
- A brief description of the problem affecting their equipment
- **Customer Priority:** *High, Medium, or Low.*
- TL-9000 Severity as described below.

### TL-9000 Severities Defined

Critical	Problems severely affecting service, traffic, capacity, or network management. They require <b>immediate corrective action</b> . (Ex. Loss of network management capability, loss of traffic imminent or existing).
Major	Conditions <b>seriously affecting</b> system operation. They require <b>immediate attention</b> . (Ex. processor outage, loss of standby equipment, loss of remote access, or network managers).
Minor	Problems not classified as critical or major.

---

# Table of Contents

	<i>Page</i>
<b>Section 1 General</b>	
1.1 INTRODUCTION .....	1-1
1.2 CONTENT.....	1-1
<b>Section 2 Operation</b>	
2.1 GENERAL .....	2-1
2.2 TURN-ON.....	2-1
2.3 USER SYSTEM INTERFACE (USI) PROVISIONING FUNCTION/OPERATION .....	2-2
2.4 OPERATING PROCEDURES .....	2-2
2.4.1 Radio Receiver Manual Switching .....	2-2
2.4.2 Radio Transmitter Manual Switching .....	2-5
2.4.3 Radio I/O Interface Manual Switching .....	2-5
2.4.4 MCS-11 Operation .....	2-7
2.4.5 Lamp Tests .....	2-8
2.4.6 Alarm Checks .....	2-8
2.4.7 Orderwire Operation .....	2-8
2.4.8 Initiating Outgoing Orderwire Calls .....	2-8
2.4.9 Answering Incoming Orderwire Calls .....	2-8
2.5 TURN-OFF PROCEDURE .....	2-9
2.6 EMERGENCY OPERATION .....	2-9
2.7 MODEM OPERATION.....	2-9
2.8 CONTROLS, INDICATORS, TEST POINTS, AND CONNECTORS .....	2-9
<b>Section 3 Interconnect</b>	
3.1 SECTION INTRODUCTION .....	3-1
3.2 POWER CABLE CONNECTION .....	3-1
3.3 PDU STRAPPING AND CONNECTIONS.....	3-4
3.4 SHELF/RACK ALARM CONNECTION .....	3-5

	<i><b>Page</b></i>
3.5 MDR-8000 SYNCHRONOUS REPEATER CONNECTIONS .....	3-5
3.5.1 Low Capacity DS1 Radios .....	3-7
3.5.2 High Capacity DS3 Radios .....	3-7
3.5.3 High Capacity OC3 Radios .....	3-7
3.5.4 MDR-8000 Synchronous Repeater Compatibility Matrix .....	3-8
3.5.5 MDR-8000 Synchronous Repeater Cables .....	3-8
3.6 DS1 CONNECTIONS (J303 IN AND J304 OUT) .....	3-9
3.7 DS1 REPEATER (J314 ON ONE SHELF TO J314 ON SECOND SHELF) .....	3-11
3.8 DS3 LBO STRAPPING AND CONNECTIONS .....	3-12
3.9 DS3 LBO DS3 BNC CONNECTIONS (J21 THROUGH J26) .....	3-13
3.10 DS3 LBO WAYSIDE DS1 CONNECTIONS (J201 IN AND J202 OUT) .....	3-14
3.10.1 Wayside DS1 Terminal .....	3-14
3.10.2 Wayside DS1 Repeater .....	3-14
3.11 DS3 REPEATER (J401 ON ONE SHELF TO J401 ON SECOND SHELF) .....	3-16
3.12 FIBER OPTIC CABLE CONNECTIONS .....	3-18
3.12.1 2 or 4 Fiber Management Panel .....	3-19
3.12.2 2x4 Fiber Switched Management Panel .....	3-19
3.13 OC3/STM-1 AUX INTERFACE BOARD WAYSIDE DS1 CONNECTIONS (J201 IN AND J202 OUT) .....	3-22
3.13.1 Wayside DS1 Terminal .....	3-22
3.13.2 Wayside DS1 Repeater .....	3-22
3.14 OC3/STM-1 REPEATER (J203 ON ONE SHELF TO J203 ON SECOND SHELF) .....	3-23
3.15 ETHERNET CABLE CONNECTIONS .....	3-24
3.15.1 Automatic MDI/MDI-X Configuration .....	3-24
3.15.2 Crossover Cable Option .....	3-25
3.15.3 Terminal Connections .....	3-29
3.15.4 Repeater Connections .....	3-33
3.16 USI/CONTROLLER CABLE CONNECTION TO LAPTOP (J301) .....	3-35
3.17 SERVICE CHANNEL CONNECTIONS .....	3-37
3.17.1 2-Wire Handset Connection .....	3-37
3.17.2 Service Channels Provisioning Options .....	3-39
3.17.3 Audio 1, Audio 2 (J316, J317) Connections .....	3-39
3.17.4 RS-232-1, RS-232-2 (J312, J313) .....	3-43

	<b>Page</b>
3.18 MCS-11 CONNECTIONS .....	3-44
3.18.1 MCS-11 Master (J307) .....	3-45
3.18.2 MCS-11 Repeater-to-Spur Daisy Chain Connection (J308/J309) .....	3-48
3.18.3 MCS-11 Spur Connection (J310) .....	3-56
3.19 TMN CONNECTIONS .....	3-58
3.19.1 Installing Module .....	3-58
3.19.2 Typical Interconnect Scenarios .....	3-60
3.19.3 Front Access Connectors .....	3-64
3.19.4 MATING CABLES .....	3-67
3.19.5 Front Panel Craft Interface Connector J5 .....	3-68
3.20 ELMC (J315, J318) .....	3-69
3.21 FOREIGN ALARM INTERFACE (J305) .....	3-72
3.22 ALARM, STATUS, AND CONTROLS INTERCONNECT .....	3-75
3.22.1 Controller Bus .....	3-77
3.22.2 Control Inputs .....	3-77
3.22.3 Station Alarm Inputs/TBOS Interface .....	3-77
3.22.4 Station Alarm Wiring .....	3-78
3.22.5 Relay Alarm/Status Outputs .....	3-79
3.22.6 Relay Control Outputs .....	3-80
<b>Section 4 Initial Turnup</b>	
4.1 SECTION INTRODUCTION .....	4-1
4.2 RECOMMENDED SEQUENCE .....	4-1
4.3 SECURITY MANAGEMENT .....	4-2
4.4 LOAD MDR-8000 SOFTWARE ON PC .....	4-2
4.5 TURN-ON PROCEDURE .....	4-4
4.6 ESTABLISH COM PORT .....	4-4
4.7 TEST PROCEDURES .....	4-7
4.8 PROVISIONING RADIO .....	4-7
4.9 PROVISION ETHERNET FACILITY .....	4-29
4.9.1 Auto-Negotiation .....	4-30
4.10 PROVISION DS1 FACILITY .....	4-32

**Section 5 Maintenance**

5.1	INTRODUCTION .....	5-1
5.2	MAINTENANCE PHILOSOPHY .....	5-2
5.3	RECOMMENDED TEST EQUIPMENT .....	5-4
5.4	OPTIONAL TEST EQUIPMENT .....	5-4
5.5	PERSONAL COMPUTER (PC)/LAPTOP .....	5-5
5.6	MDR-8000 ALARMS .....	5-7
5.7	ALARM MONITORING AND INSPECTION .....	5-7
5.8	RECOMMENDED PERIODIC CHECKS .....	5-8
5.9	RADIO TROUBLESHOOTING .....	5-8
5.9.1	Troubleshooting USI Alarms .....	5-8
5.9.2	Troubleshooting RCVR Lockup Problems .....	5-8
5.9.3	Troubleshooting Performance Screen Errors .....	5-9
5.10	ETHERNET-SPECIFIC TROUBLESHOOTING .....	5-24
5.10.1	Troubleshooting Using Ethernet I/O Interface Module Front Panel Indicators .....	5-24
5.11	TMN-SPECIFIC TROUBLESHOOTING .....	5-26
5.12	MODULE REPLACEMENT .....	5-29
5.13	POWER SUPPLY REMOVAL AND REPLACEMENT .....	5-32
5.14	CONTROLLER REMOVAL AND REPLACEMENT .....	5-33
5.15	DS3 I/O INTERFACE REMOVAL AND REPLACEMENT .....	5-37
5.16	OC3/STM-1/ETH I/O INTERFACE REMOVAL AND REPLACEMENT .....	5-39
5.17	XMTR REMOVAL AND REPLACEMENT .....	5-40
5.18	XMT CRYSTAL OSCILLATOR FREQUENCY CORRECTION .....	5-46
5.19	XMTR OUTPUT LEVEL CHECK (NO PA) .....	5-47
5.20	IN-SERVICE XMTR CARRIER NULL ADJUSTMENT USING SPECTRUM ANALYZER .....	5-48
5.21	XMTR OUTPUT LEVEL CALIBRATION .....	5-56
5.22	RCVR REMOVAL AND REPLACEMENT .....	5-61
5.23	RCV CRYSTAL OSCILLATOR FREQUENCY CORRECTION .....	5-64
5.24	PA REMOVAL AND REPLACEMENT .....	5-65
5.25	PA OUTPUT LEVEL CALIBRATION .....	5-67
5.26	CHANGING FREQUENCY .....	5-72
5.27	CLEANING .....	5-72



## Section 6 User Guide

6.1	INTRODUCTION .....	6-1
6.2	ANALOG SCREEN .....	6-1
6.2.1	PA (DC MON) .....	6-1
6.2.2	TX (PWR MON) .....	6-1
6.2.3	ATPC Voltage .....	6-1
6.2.4	RX (RSL 1) dBm .....	6-1
6.2.5	RX (EYE MON) .....	6-1
6.2.6	RX (AFC MON).....	6-1
6.2.7	Battery Voltage .....	6-1
6.3	DS1/E1 RADIO PERFORMANCE SCREEN .....	6-3
6.3.1	Repeater CRC Err Sec .....	6-3
6.3.2	Radio Severe Err Sec.....	6-3
6.3.3	Radio Outage Sec.....	6-3
6.3.4	Radio A and B Outage Sec .....	6-3
6.3.5	Radio CRC Err Sec .....	6-3
6.3.6	Radio CRC Errors.....	6-3
6.3.7	Radio Internal BER.....	6-3
6.3.8	Radio Average BER .....	6-3
6.4	DS3 RADIO PERFORMANCE MONITORING SCREEN .....	6-5
6.4.1	Line 1-3 DS3 Errors .....	6-5
6.4.2	Line 1-3 DS3 BER .....	6-5
6.4.3	Radio Errors.....	6-5
6.4.4	Radio Error Seconds.....	6-5
6.4.5	Radio Severe Error .....	6-5
6.4.6	Radio BER .....	6-5
6.5	OC3/STM-1 RADIO PERFORMANCE MONITORING SCREENS .....	6-6
6.5.1	OC3/STM-1 Errors .....	6-6
6.5.2	OC3/STM-1 Error Seconds .....	6-6
6.5.3	OC3/STM-1 Severe Error Seconds .....	6-6
6.5.4	OC3/STM-1 Severe Error Frame.....	6-6
6.5.5	OC3/STM-1 BER .....	6-6
6.5.6	Line 1-3 DS1 Error Seconds .....	6-6
6.5.7	Radio Errors.....	6-6

6.5.8	Radio Error Seconds .....	6-8
6.5.9	Radio Severe Error .....	6-8
6.5.10	Radio BER .....	6-8
6.6	ETHERNET RADIO PERFORMANCE MONITORING SCREEN .....	6-8
6.6.1	RF Receive .....	6-8
6.6.2	GPF Receive .....	6-9
6.7	ETHERNET PERFORMANCE MONITORING SCREEN .....	6-9
6.7.1	IN (To RF Transmit) .....	6-9
6.7.2	OUT (From RF Receive) .....	6-10
6.8	DS1/E1 RADIO CONTROL SCREEN .....	6-11
6.8.1	In-Service Controls .....	6-11
6.8.2	System Loopback Controls .....	6-11
6.8.3	User Controls .....	6-11
6.8.4	DS1 Line Loopback Controls .....	6-11
6.9	DS3 RADIO CONTROL SCREEN .....	6-13
6.9.1	In-Service Controls .....	6-13
6.9.2	System Loopback Controls .....	6-13
6.9.3	User Controls .....	6-14
6.9.4	Wayside DS1 Line Loopback Controls .....	6-14
6.10	OC3/STM-1 RADIO CONTROL SCREEN .....	6-16
6.10.1	In-Service Controls .....	6-16
6.10.2	System Loopback Controls .....	6-16
6.10.3	User Controls .....	6-16
6.11	ETHERNET RADIO CONTROL SCREEN .....	6-18
6.11.1	In-Service Controls .....	6-18
6.11.2	User Controls .....	6-18
6.11.3	System Loopback .....	6-19
6.11.4	DS1 Line Loopback .....	6-21
6.11.5	Inventory Screen .....	6-24

## SAFETY PRECAUTIONS

While the manufacturer has attempted to detail in this manual all areas of possible danger to personnel in connection with the use of this equipment, personnel should use caution when installing, checking out, operating, and servicing this equipment. As with all electronic equipment, care should be taken to avoid electrical shock in all circuits where substantial currents or voltages may be present, either through design or short circuit.

Definitions of Danger, Warnings, Cautions, and Notes used throughout this manual are described below:



***An operating procedure, practice, etc., which, if not correctly followed could result in personal injury or loss of life.***



***An operating procedure, practice, etc., which, if not strictly observed, could result in damage to or destruction of equipment.***



***An operating procedure, practice, etc., which, if not correctly followed, could result in an interruption of service.***

### Note

***An operating procedure, condition, etc., which is essential to highlight.***



# 1 GENERAL

## 1.1 INTRODUCTION

This MDR-8000 Users Manual contains information on the MDR-8000 Hot-Standby Shelf. For information on the MDR-8000 Compact Indoor Shelf, and MDR-8000 Compact Outdoor Unit Refer to CD.

The information in the Users Manual is a summary of the overall Operation and Maintenance Manual that is located on the attached CD. The summary information is provided to support initial turnup, day-to-day operation, and maintenance of the MDR-8000 equipment.

## 1.2 CONTENT

Refer to Table 1-1. The Attached CD column lists the parts of the *MDR-8000 Radio Family Operation and Maintenance Manual*, PN 3EM20188AAAA. A check mark under the Users Manual column or the Attached CD column indicates where the information is located.

Table 1-1 Information Location

Section/Appendix	Location	
	<i>Users Manual</i>	<i>Attached CD</i>
Glossary		√
General		
Ordering Information		√
Features and Options		√
Supplied and Optional equipment		√
Part Numbers		√
Physical, Environmental, and Electrical Characteristics		√
Application		√
Functional Description		√
Physical Installation		√
Interconnect	√	√
DS1/E1, DS3, OC3/STM-1, and ETH	√	√
Service Channel	√	√
Initial Turnup	√	√
Radio Provisioning	√	√
TMN Specifics		√
Operation	√	√
Controls and Indicators	√	√
Users Guide	√	√
USI Screen Descriptions	√	√

**Table 1-1 (Cont.) Information Location**

<b>Section/Appendix</b>	<b>Location</b>	
	<i>Users Manual</i>	<i>Attached CD</i>
Maintenance	√	√
Troubleshooting USI Alarms	√	√
Troubleshooting Using Performance Screens	√	√
Troubleshooting TMN Alarms	√	√
Module Replacement Procedures	√	√
Post-Replacement Test procedures	√	√
Diagrams		√
Rack Installation		√
Alarm/Status/Control		√
MCS-11 Reference Guide		√
Modem Provisioning		√
Maintenance Support Procedures		√
Optional Over-The-Hop Performance Tests		√
Compact Indoor Shelf		√
Compact Outdoor Unit		√
Ethernet + 4 DS1 Upgrade Procedure		√
Ethernet + 32 DS1 Upgrade Procedure		√

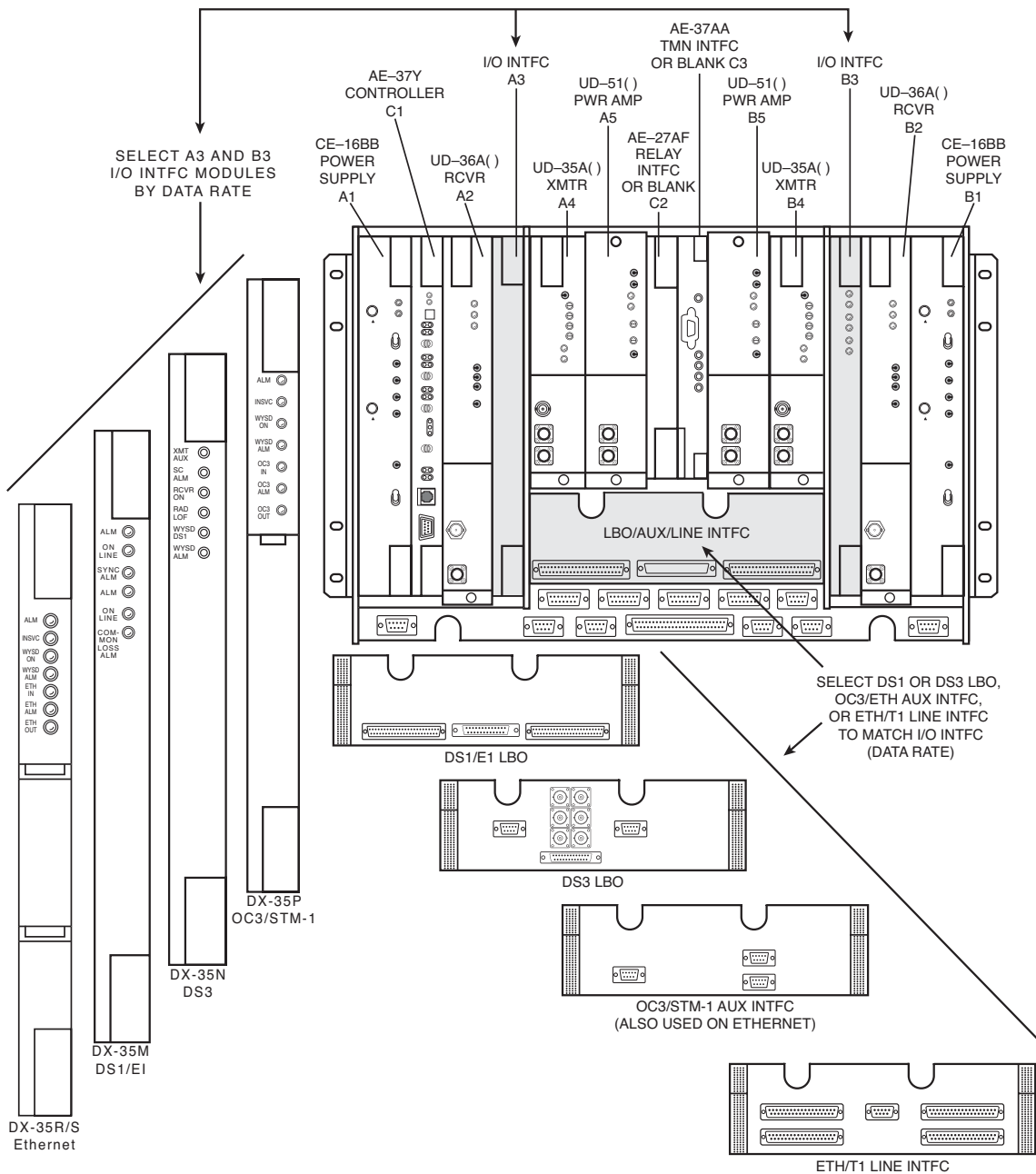

MDR-1305  
07/21/07

Figure 1 -1 Typical MDR-8000 Hot-Standby Shelf Component Locations and Options (Sheet 1 of 3)

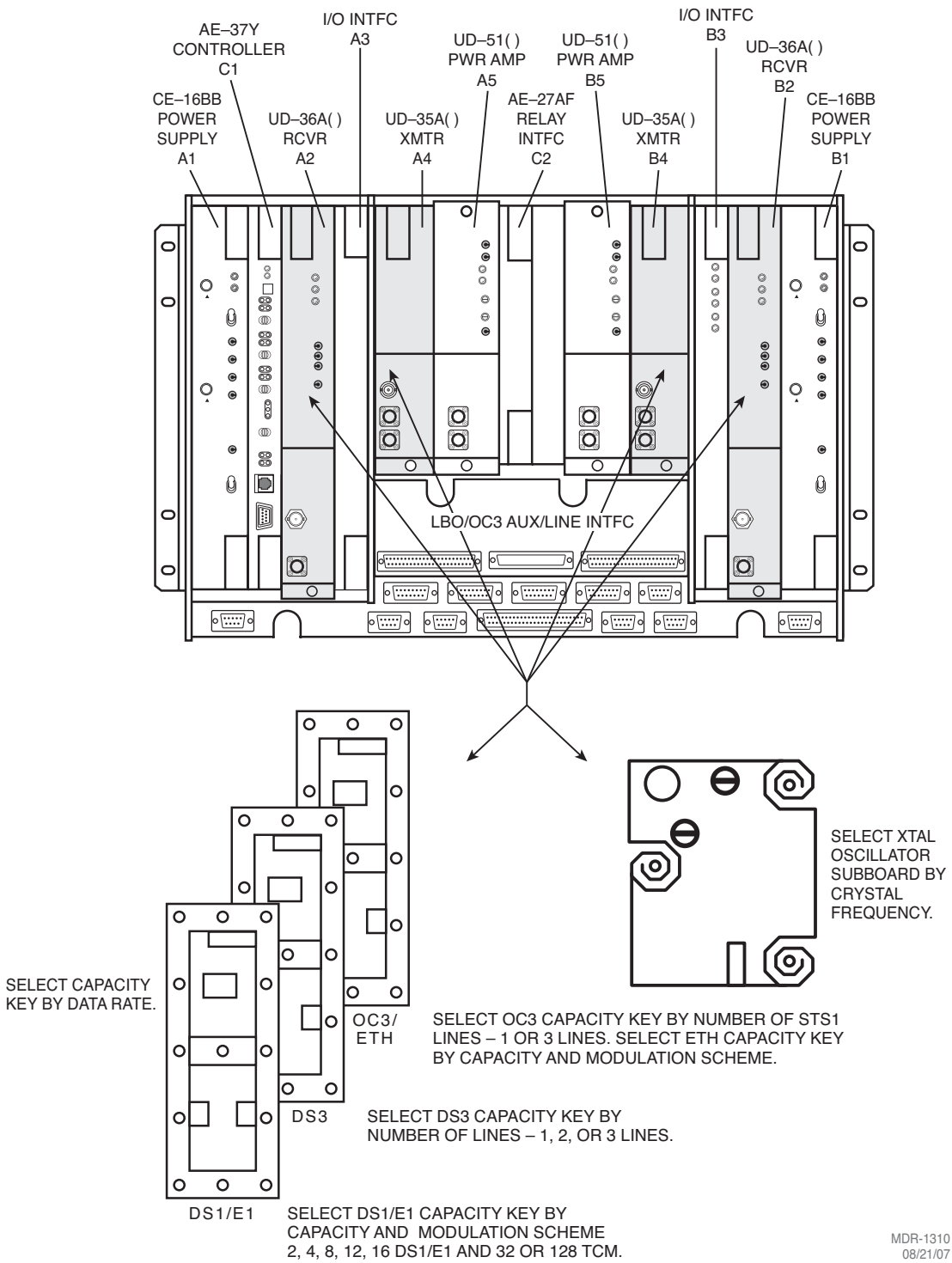

MDR-1310  
08/21/07

Figure 1-1 Typical MDR-8000 Hot-Standby Shelf Component Locations and Options (Sheet 2 of 3)



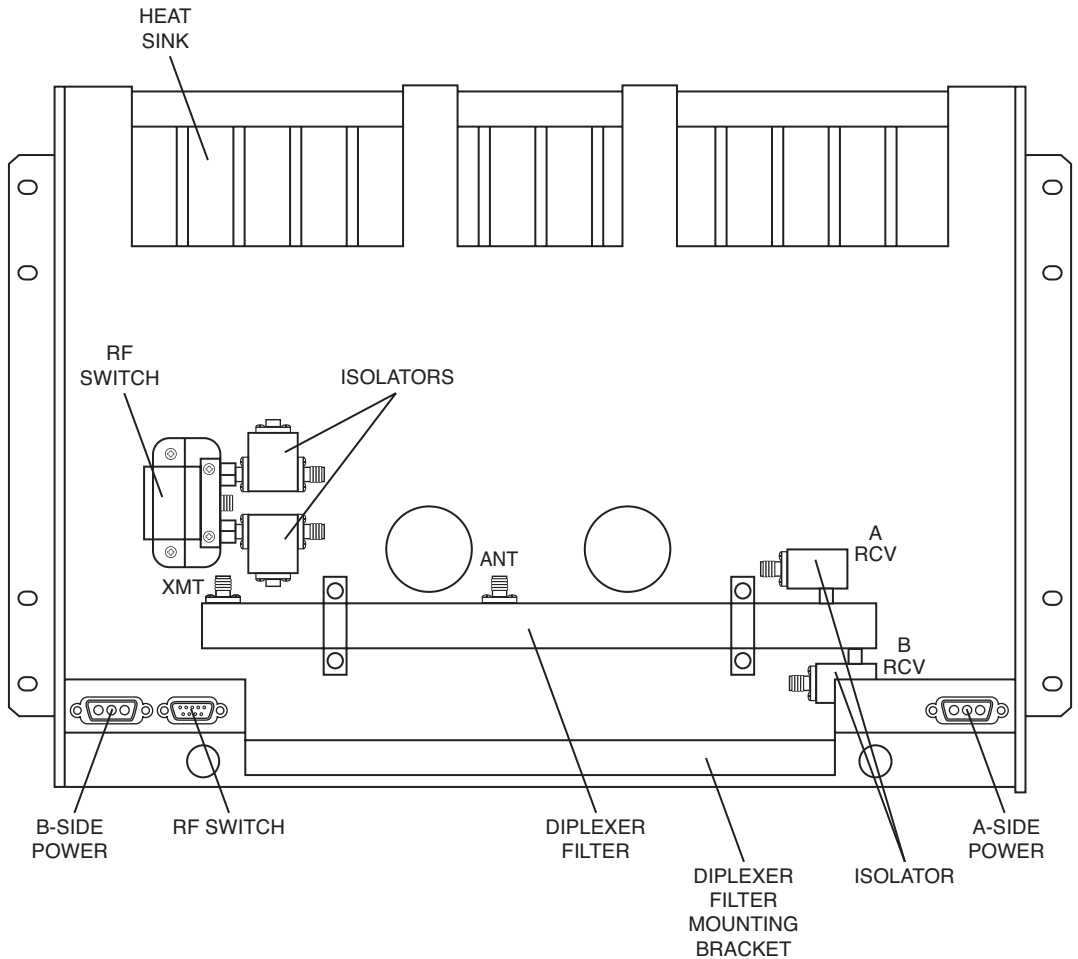

**REAR VIEW**  
 (TYPICAL HOT-STANDBY 1:10 COUPLER  
 SINGLE ANTENNA CONFIGURATION)

**Note**

*Location of A and B RCV ports on diplexer filter varies, depending on RF frequency. For some frequencies, A and B ports reverse location.*

LMW-7211-SM  
 06/08/04

Figure 1-1 Typical MDR-8000 Hot-Standby Shelf Component Locations, and Options (Sheet 3 of 3)



**Note**

*The information contained in this section is a summary of the section with the same title, but not the same section number, on the enclosed CD. "Refer to CD" is used throughout this section to refer the reader to the detail information on the CD. Go to this section on the CD for interactive links to the detail information referred to in this section.*

## 2 OPERATION

### 2.1 GENERAL

This section contains turn-on, normal operation, turn-off, and emergency operating procedures plus a description of controls, indicators, test points, and connectors for the MDR-8000 Series Microwave Digital Radios.

**Note**

*Before performing any procedures, operating personnel should become familiar with the locations of power distribution units and circuit breakers. If an equipment performance problem occurs during the following procedures, refer to the Maintenance section.*

### 2.2 TURN-ON

The radio is designed to operate continuously without operator intervention. After initial installation and power turn-on, operating procedures are limited to periodic visual lamp checks, alarm checks, and answering or initiating orderwire service calls. Turn-on procedures are needed only if the system has been turned off due to a malfunction or during maintenance.

**WARNING**

*Possibility of  
Damage  
to Equipment*

***Exposure to energy radiated at microwave frequencies can cause eye damage and eventual blindness. Do not operate the system with either the transmit or the receive waveguide port unterminated. Do not look into the waveguide run or the antenna of an operating radio.***

**Note**

*Until all radios in the transmission link are interconnected, turned on, and operating properly, alarm conditions may exist.*

Perform the following procedure to turn on the MDR-8000 series radios:

- 1 On all power supply modules, set power ON/OFF switches to ON.

- 2 Verify that power distribution unit rack alarm indicator (if any) is not lighted. If indicator is lighted, troubleshoot as described in the Maintenance section.
- 3 Verify that no red indicators are lighted. If a red indicator is lit, troubleshoot as described in the Maintenance section.
- 4 Perform lamp test by momentarily holding OVRD-ACO/LT switch on controller to ACO/LT. All indicator lamps/LEDs should light.

### 2.3 USER SYSTEM INTERFACE (USI) PROVISIONING FUNCTION/OPERATION

The User System Interface (USI) software is used for maintenance and support of the radio including fault and status reporting. Refer to the Initial Turn-Up section for instructions on loading and running the software. Refer to the User's Guide section for descriptions and functions of the menus.

#### Note

*Refer to the Software Release Notes before performing any operating, provisioning, or maintenance function on this equipment. The Software Release Notes may contain information affecting these functions that is not contained in this instruction manual.*

### 2.4 OPERATING PROCEDURES

#### Note

*The USI computer is the main control for the radio. If instructions for setting up the USI computer are needed, refer to Initial Turn-Up section.*

After installation and turn-on, operating procedures are limited to periodic alarm checks and, when necessary, answering or initiating orderwire calls. Automatic and manual switching are provided for equipment protection. Manual switching may be accomplished using the Control screen on the USI computer or the switches on the front panel of the controller module. The following paragraphs provide operating procedures for manual switchover of protected radio systems.

#### 2.4.1 Radio Receiver Manual Switching

#### Note

*When used in conjunction with a RCVR manual switch, press the OVRD switch to lock the receiver on line regardless of alarms. Press again to unlock.*

##### Controller Switch

Perform RCVR manual switch (Figure 2-1) using controls on front panel of controller module:

##### USI Switch

Perform RCVR manual switch (Figure 2-2) using the USI control screen.

TOGGLE SWITCH LEFT TO SWITCH A XMTR, RCVR, OR I/O MODULE IN-SERVICE AND TOGGLE SWITCH RIGHT TO SWITCH B XMTR, RCVR, OR I/O MODULE IN-SERVICE.

**NOTE**

OVERRIDE (OVRD) LOCKS XMTR, RCVR, OR I/O MODULE, SELECTED ABOVE IN-SERVICE, REGARDLESS OF ALARMS.

**TO ENABLE OVERRIDE:**

1. PRESS AND HOLD TX A/B ON LINE, RX A/B ON LINE, OR I/O A/B ON LINE SWITCH.
2. TOGGLE ACO/LT OVRD SWITCH TO OVRD POSITION.
3. RELEASE A/B ON LINE SWITCH.

**TO DISABLE OVERRIDE:**

TOGGLE ACO/LT OVRD SWITCH TO OVRD POSITION.



USI-5078  
02/12/07

Figure 2-1 Manual Switch From Controller Front Panel

1. OPEN USI CONTROLS SCREEN.

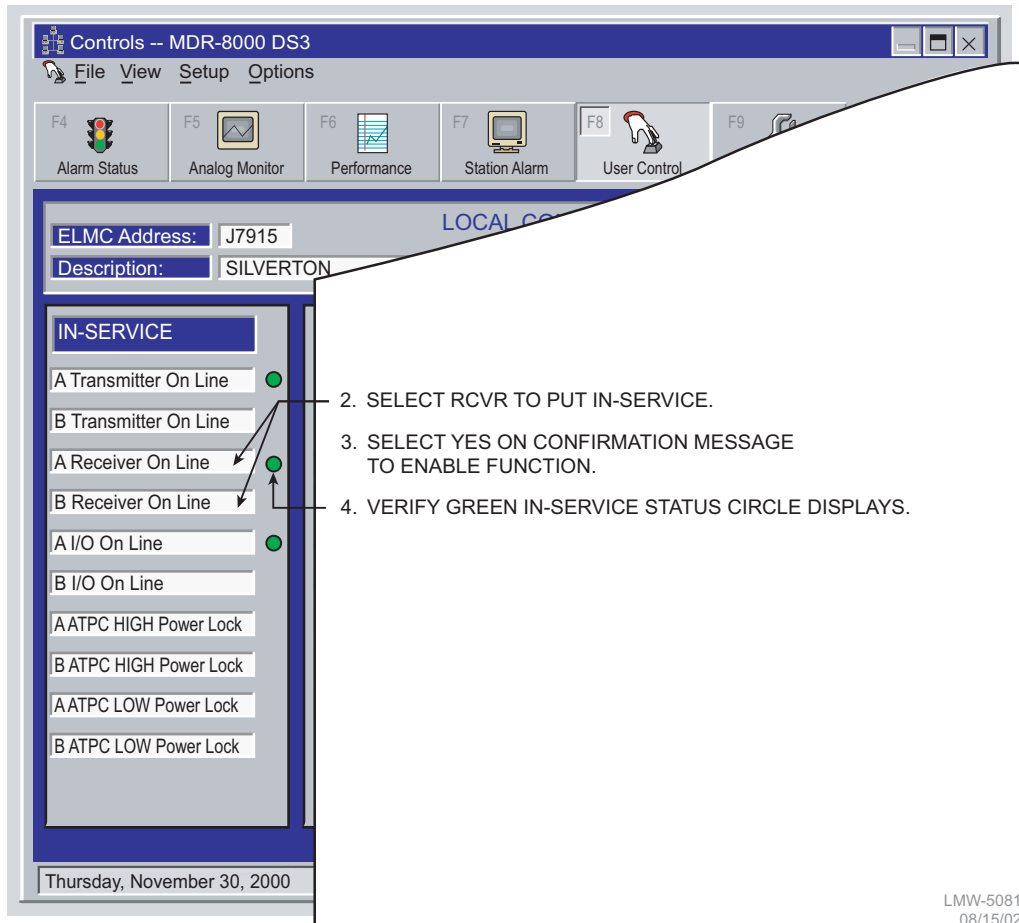

LMW-5081  
08/15/02

Figure 2-2 RCVR Manual Switch Using USI Control Screen

## 2.4.2 Radio Transmitter Manual Switching



***Switching the radio transmitter may momentarily interrupt traffic. Before switching the transmitter, obtain permission from the proper authority.***

### Note

*When used in conjunction with a XMTR manual switch, press the OVRD switch to lock the XMTR on line regardless of alarms. Press again to unlock.*

#### Controller Switch

Perform XMTR manual switch (Figure 2-1) using controls on front panel of controller module.

#### USI Switch

Perform XMTR manual switch (Figure 2-3) using the USI control screen.

## 2.4.3 Radio I/O Interface Manual Switching



***Traffic and auxiliary channel service will be momentarily interrupted. Obtain proper authorization before making this switch.***

### Note

*When used in conjunction with an I/O interface manual switch, press the OVRD switch to lock the I/O interface on line regardless of alarms. Press again to unlock.*

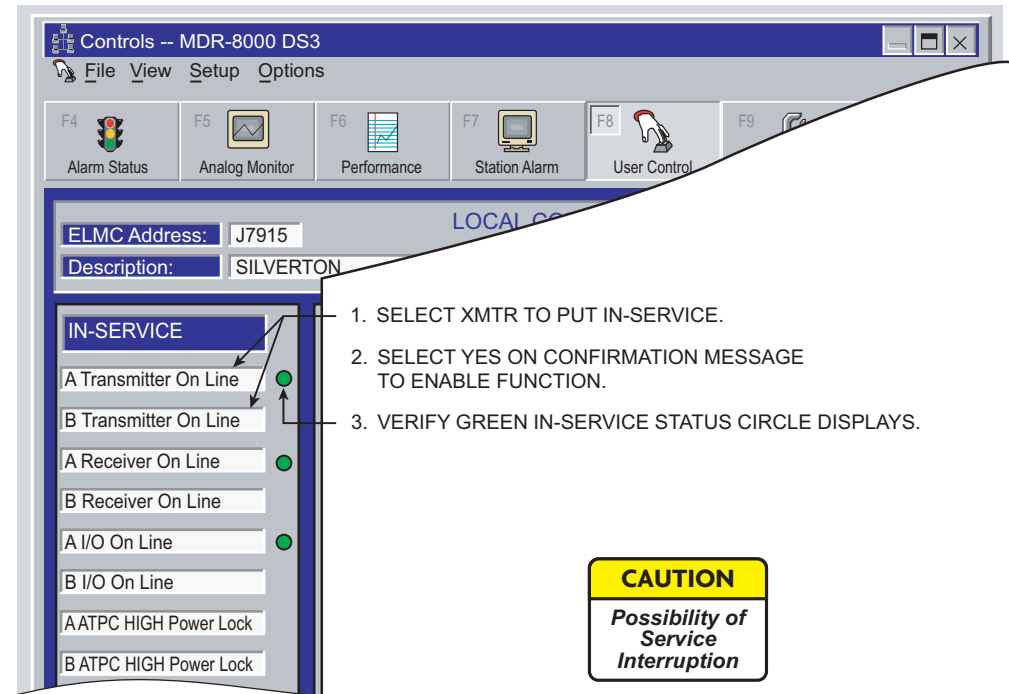

*Switching the radio transmitter may momentarily interrupt traffic. Switching I/Os will momentarily interrupt traffic and auxiliary channel service. Before switching, obtain permission from the proper authority.*

LMW-5076  
06/12/04

**Figure 2-3 XMTR Manual Switch Using USI Control Screen**

#### Controller Switch

Perform I/O manual switch (Figure 2-1) using controls on front panel of controller module.

#### USI Switch

Perform I/O manual switch (Figure 2-4) using the USI control screen.



1. OPEN USI CONTROLS SCREEN.

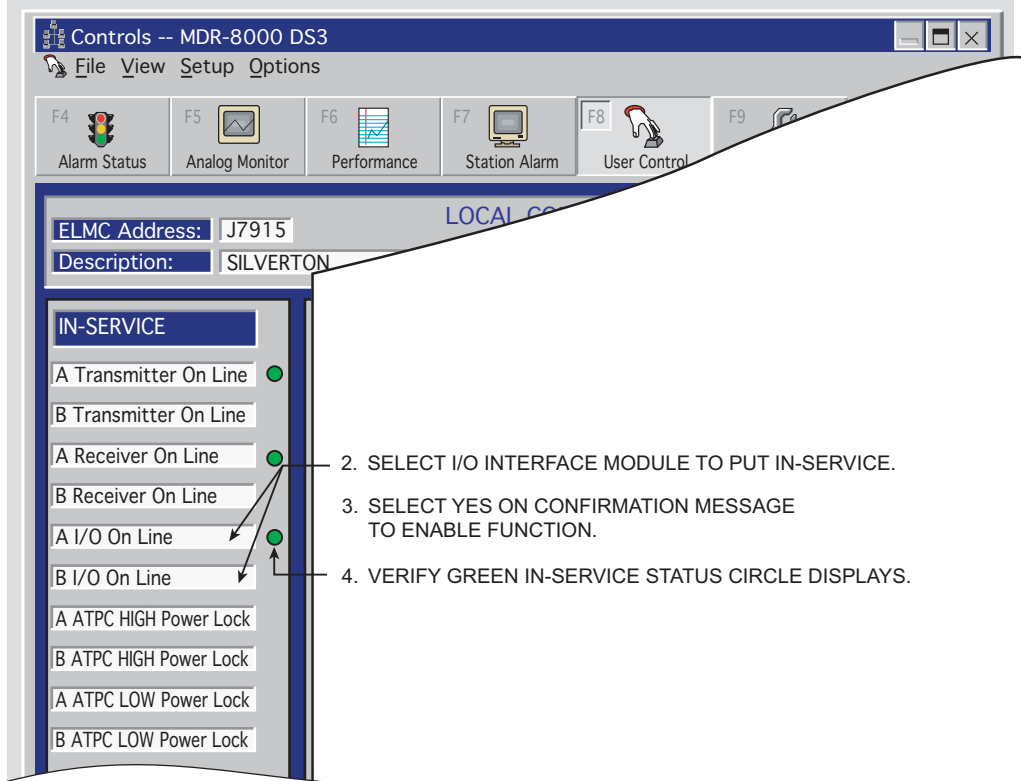

LMW-5077  
08/15/02

Figure 2-4 I/O Manual Switch Using USI Control Screen

#### 2.4.4 MCS-11 Operation

An Operational Support System (OSS) provides a means to remotely monitor and control an MDR-8000 radio via an MCS-11 Monitor and Control System polling master. A Remote Station Summary (RSS), a Remote Detail Scanner (RDS), a Remote Analog Scanner (RAS), and a Remote Control Decoder (RCD) are available at the polling master for each radio network element. The remote station OSS addresses are programmed during radio provisioning using the USI laptop computer. (Refer to radio provisioning in the Initial Turn-Up section.) Refer to the attached CD for MCS-11 details, including alarm/status mapping and connector information.

#### 2.4.5 Lamp Tests

Perform lamp tests by pressing and holding ACO/LT OVRD switch on controller front panel in ACO/LT position. All indicators on controller and indicators on all equipped modules should light. Release ACO/LT OVRD switch.

#### 2.4.6 Alarm Checks

The USI Alarm and Status screens provide alarms and status for the radio. Refer to description of alarms and status in the maintenance section.

#### 2.4.7 Orderwire Operation

These operating procedures describe use of the orderwire system to answer incoming calls and initiate outgoing calls. The DTMF function allows the user to ring the dialed station.

#### 2.4.8 Initiating Outgoing Orderwire Calls

- 1 Connect telephone to J302 TEL jack on front panel of AE-37() Controller.
- 2 Dial the 3-digit DTMF extension on the telephone keypad to call specific party or press the \* key on keypad to initiate CALL signaling to all stations.

#### 2.4.9 Answering Incoming Orderwire Calls

**Note**

*Call can be heard by all stations.*

- 1 When the buzzer sounds, alerting the operator there is an incoming call, connect telephone to J302 TEL jack on front panel of AE-37() Controller and turn ON-HOOK/OFF-HOOK switch to OFF-Hook position.
- 2 To terminate call, turn ON-HOOK/OFF-HOOK switch to ON-Hook position.

**Note**

*During the DTMF dialing process, if an incorrect number sequence has been dialed, press # to reset DTMF digit accumulator to zero. A redial can then be initiated.*

**Note**

*If 1.5 seconds elapse between dialed digits, the DTMF digit accumulator resets to zero, and a redial must be initiated.*

**Note**

*Caller can press # to clear all flashing CALL indicators at all DTMF sites equipped with the DTMF signaling option (a tone is transmitted).*

## 2.5 TURN-OFF PROCEDURE

The radio is designed for continuous operation. If power must be removed while performing maintenance on a particular cabinet or shelf, power can be removed by turning off associated power supplies.

**Note**

*Normally, the turn-off procedures are not used. System design allows maintenance of the rack without interrupting service. It is recommended that turn-off be performed only in an emergency.*

## 2.6 EMERGENCY OPERATION

If an emergency occurs, such as a short circuit or a fire, turn off all MDR-8000 Microwave Digital Radio power supplies as quickly as possible.

## 2.7 MODEM OPERATION

Refer to the attached CD for modem connection and setup procedures.

## 2.8 CONTROLS, INDICATORS, TEST POINTS, AND CONNECTORS

**CAUTION**

*Possibility of  
Service  
Interruption*

***Do not adjust controls unless instructed to do so in an installation or maintenance procedure. Unauthorized adjustment of controls illustrated and described in this section may interrupt traffic and/or degrade system performance.***

Controls, indicators, test points, and connectors used in normal operation or referenced in procedures are shown in Figure 2-5 through Figure 2-17. The figures are arranged in alphabetical order according to the type number. Current module versions are illustrated. Refer to CD for older versions.

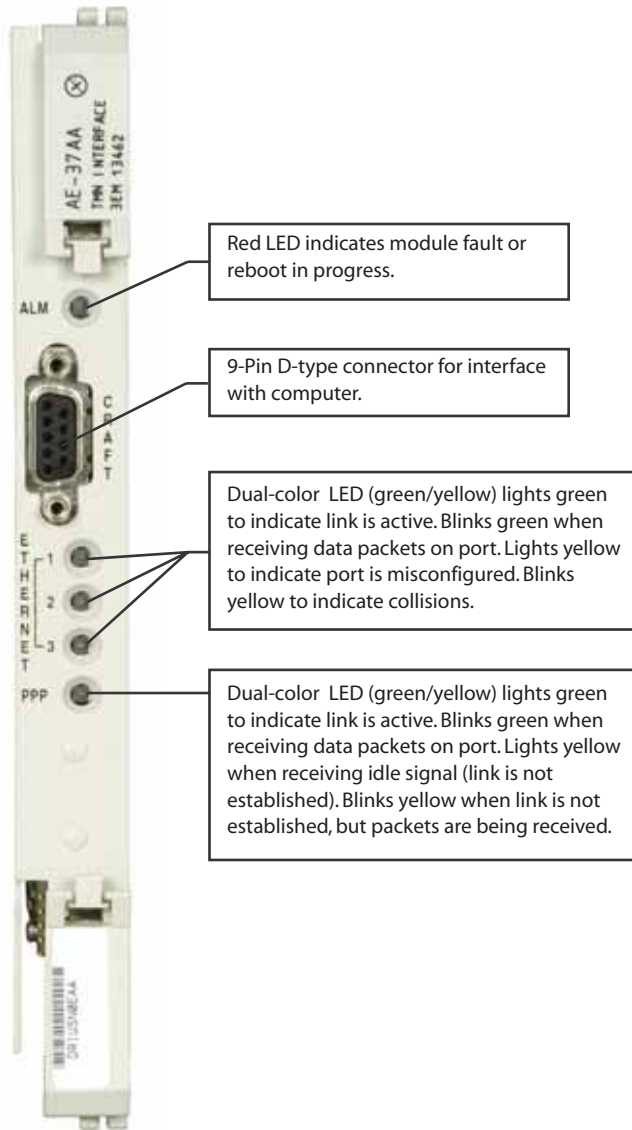

Figure 2-5 AE-37AA TMN Interface Module Controls, Indicators, and Connectors (Sheet 1 of 2)

Ethernet 1 RJ-45 connector for uplink connection to Ethernet hub, switch, or router

Ethernet 2 and 3 RJ-45 connectors for normal/bridged connection to other SNMP ports of other NEs (radio, MUX, computers)

Point-to-Point (PPP) RJ-45 connector for connection to other radio TMN INTFC PPP ports. Can support backhaul connection over channel bank or synchronous modem with appropriate cable



Note: LEDs are designated DS1-DS5

LMW-8047P  
02/19/07

Figure 2-5 AE-37AA TMN Interface Module Controls, Indicators, and Connectors (Sheet 2 of 2)

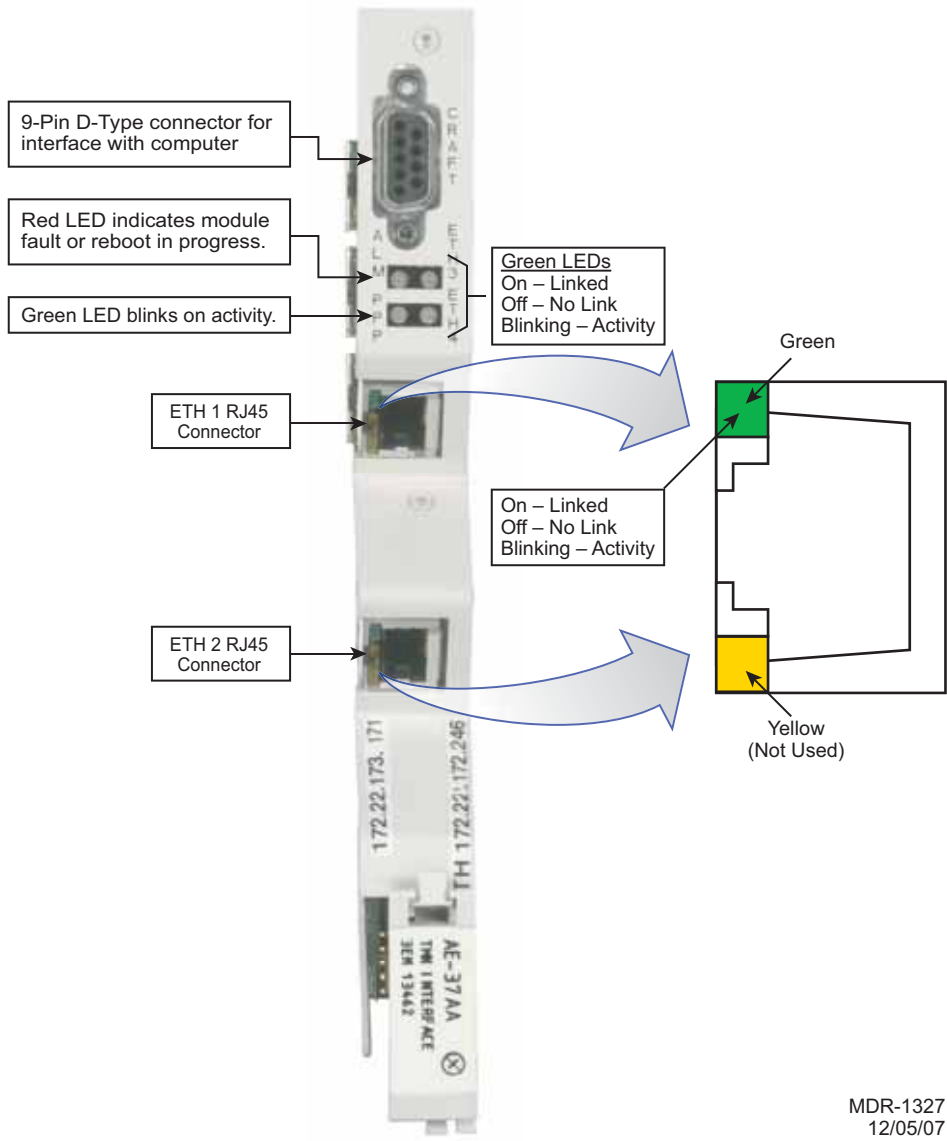
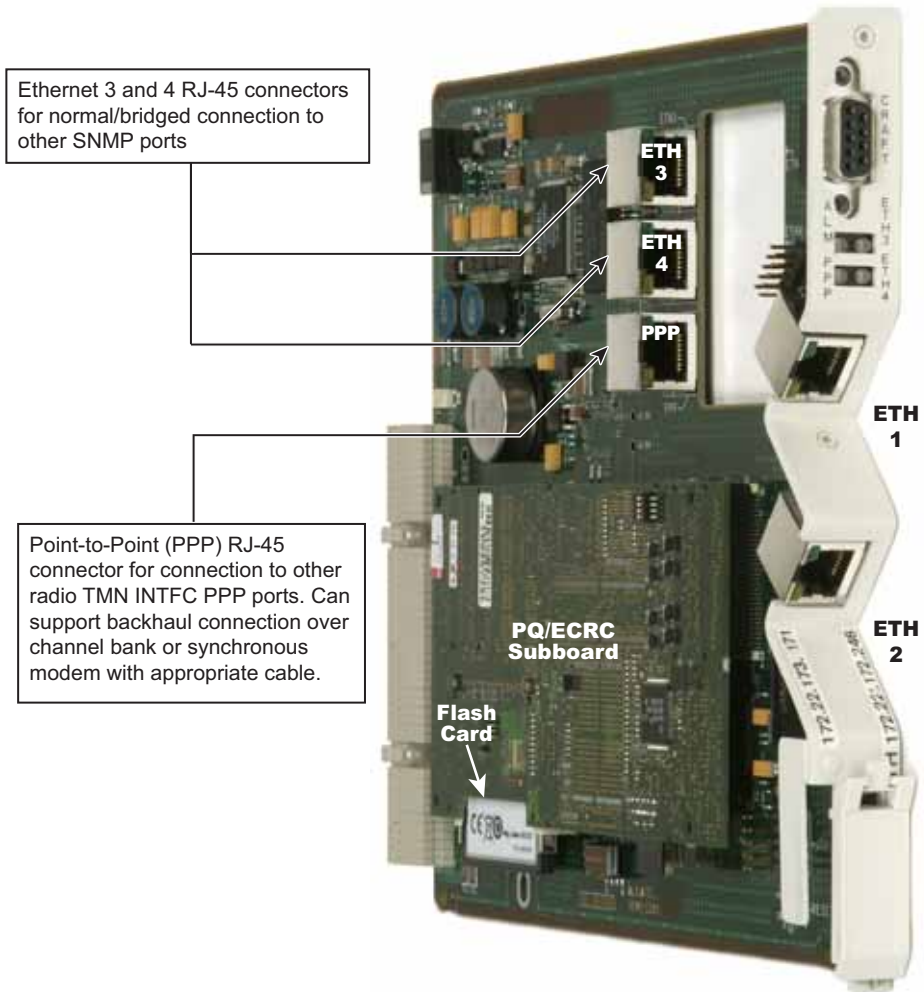

Figure 2-6 AE-37AA TMN Interface Module (PN 3EM13462AB)  
Controls, Indicators, and Connectors (Sheet 1 of 2)



Note: LEDs are designated DS1-DS5.

MDR-1326  
12/01/07

Figure 2-6 AE-37AA TMN Interface Module (PN 3EM13462AB)  
Controls, Indicators, and Connectors (Sheet 2 of 2)

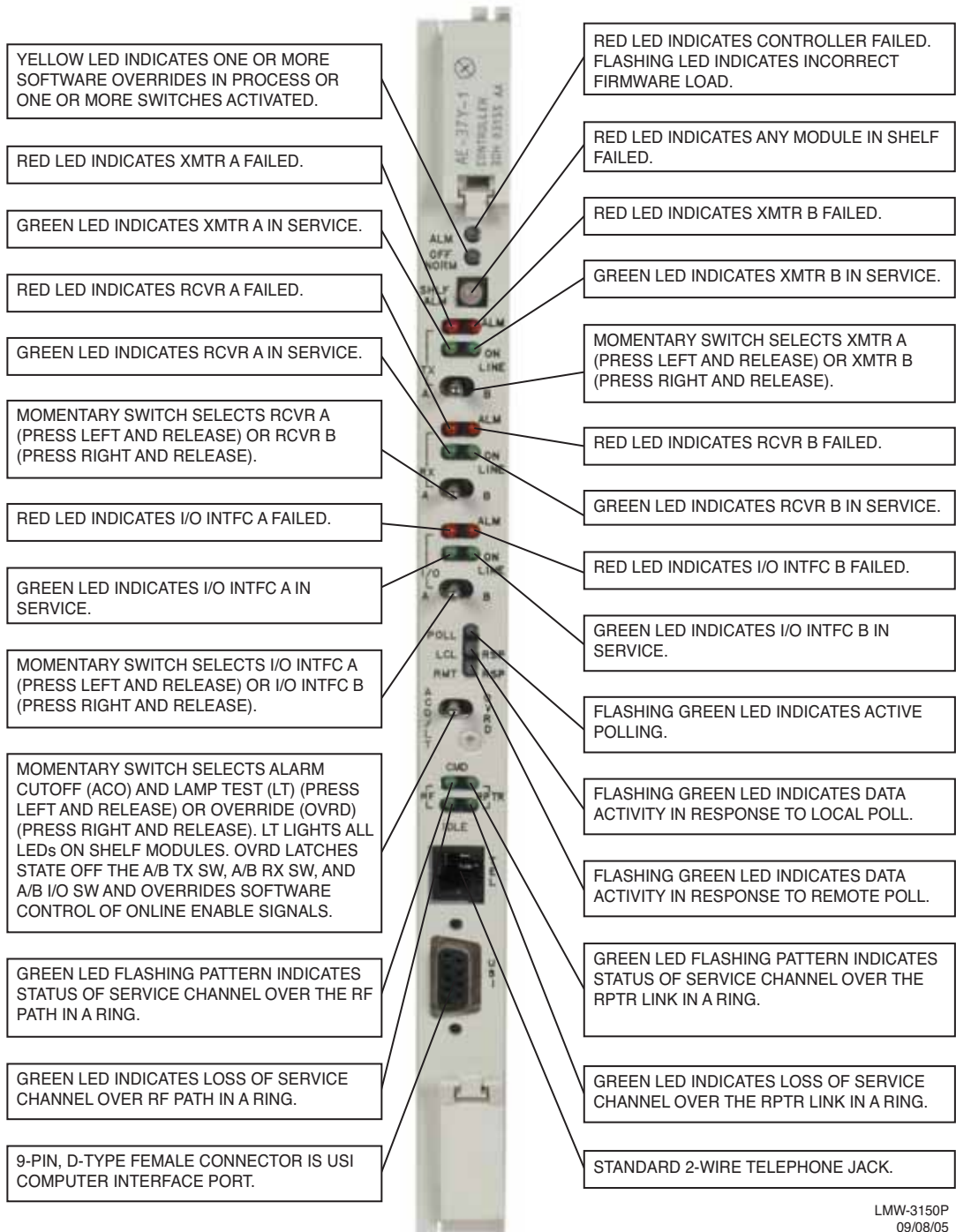

LMW-3150P  
09/08/05

Figure 2-7 AE-37() Controller Controls, Indicators, and Connectors (Sheet 1 of 2)



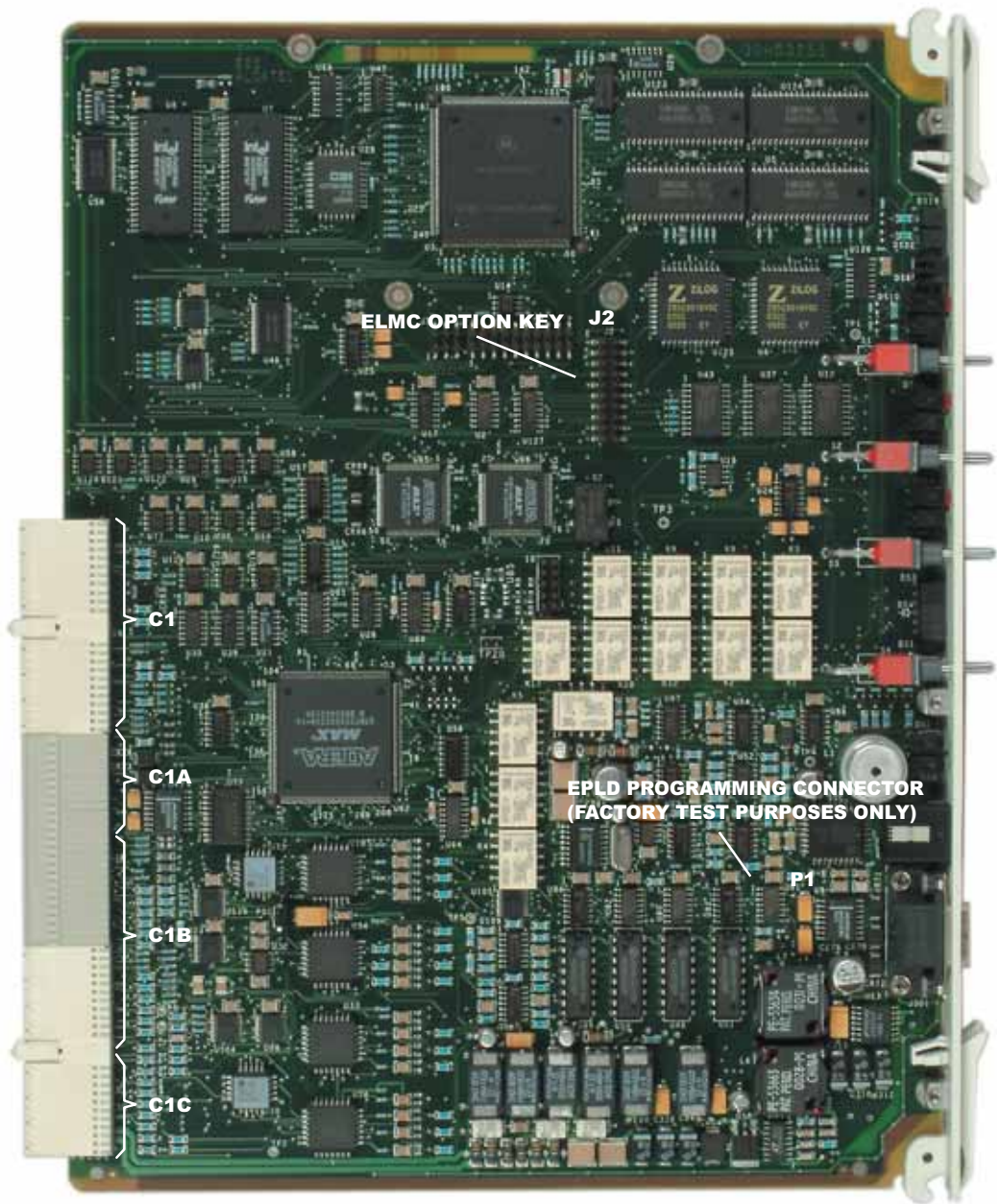

**ELMC OPTION KEY J2**

**C1**

**C1A**

**C1B**

**C1C**

**EPLD PROGRAMMING CONNECTOR  
(FACTORY TEST PURPOSES ONLY)**

**P1**

LMW-7047P  
07/18/02

Figure 2-7 AE-37() Controller Controls, Indicators, and Connectors (Sheet 2 of 2)

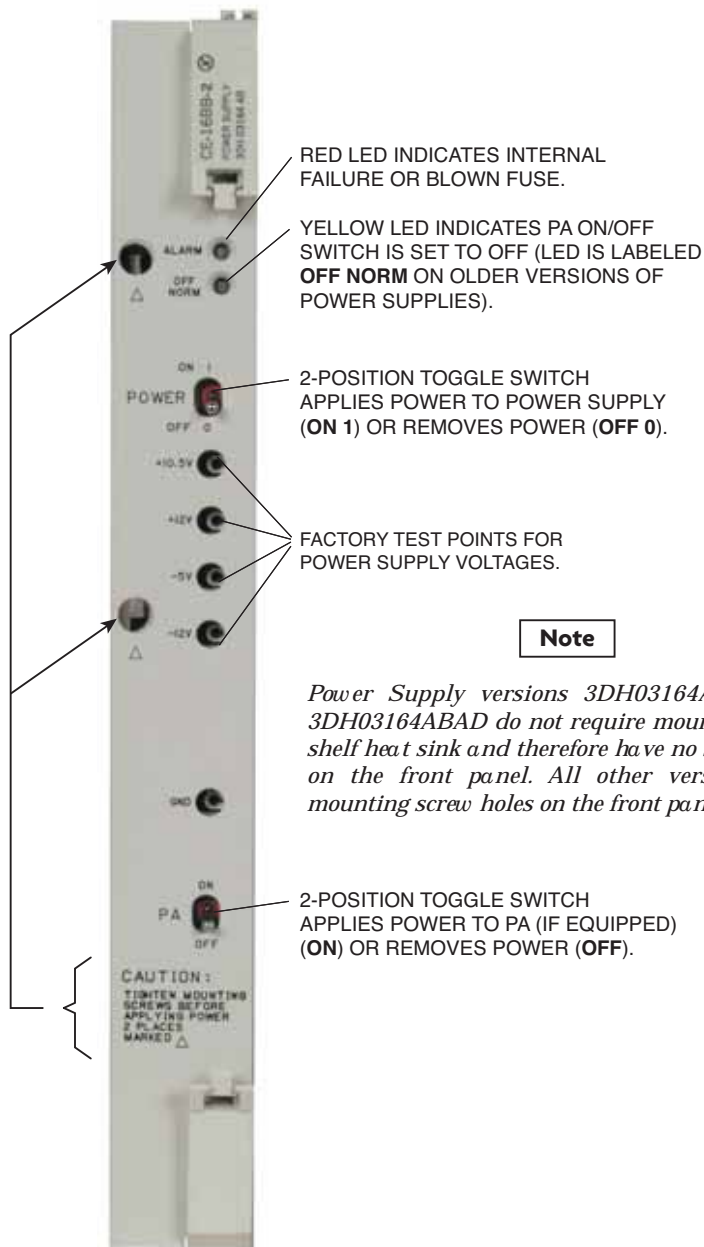

MDR-1101P  
01/13/05

Figure 2-8 CE-16BB Power Supply Controls, Indicators, Test Points, and Connectors (Sheet 1 of 2)



**SIDE VIEW OF POWER SUPPLY**

LMW-3160P  
08/15/02

Figure 2-8 CE-16BB Power Supply Controls, Indicators, Test Points, and Connectors (Sheet 2 of 2)

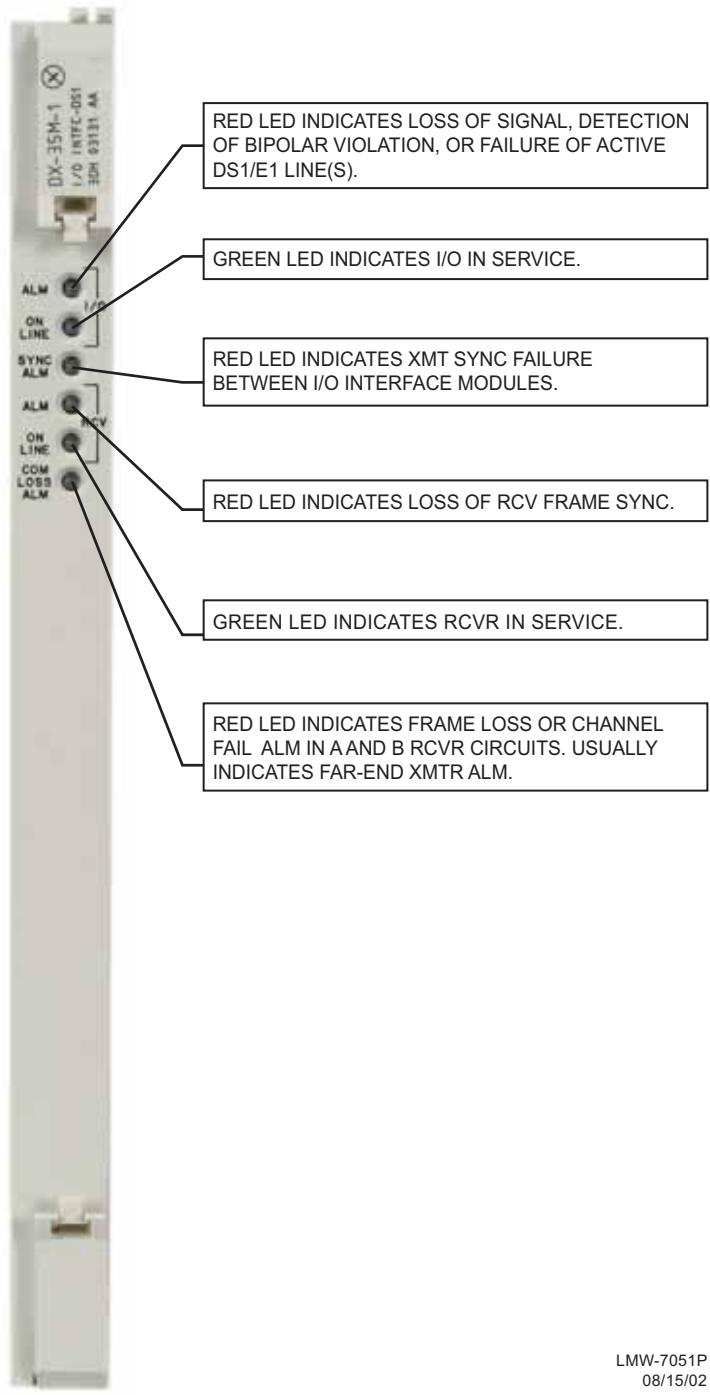

LMW-7051P  
08/15/02

Figure 2-9 DX-35M DS1 I/O Interface Controls and Indicators

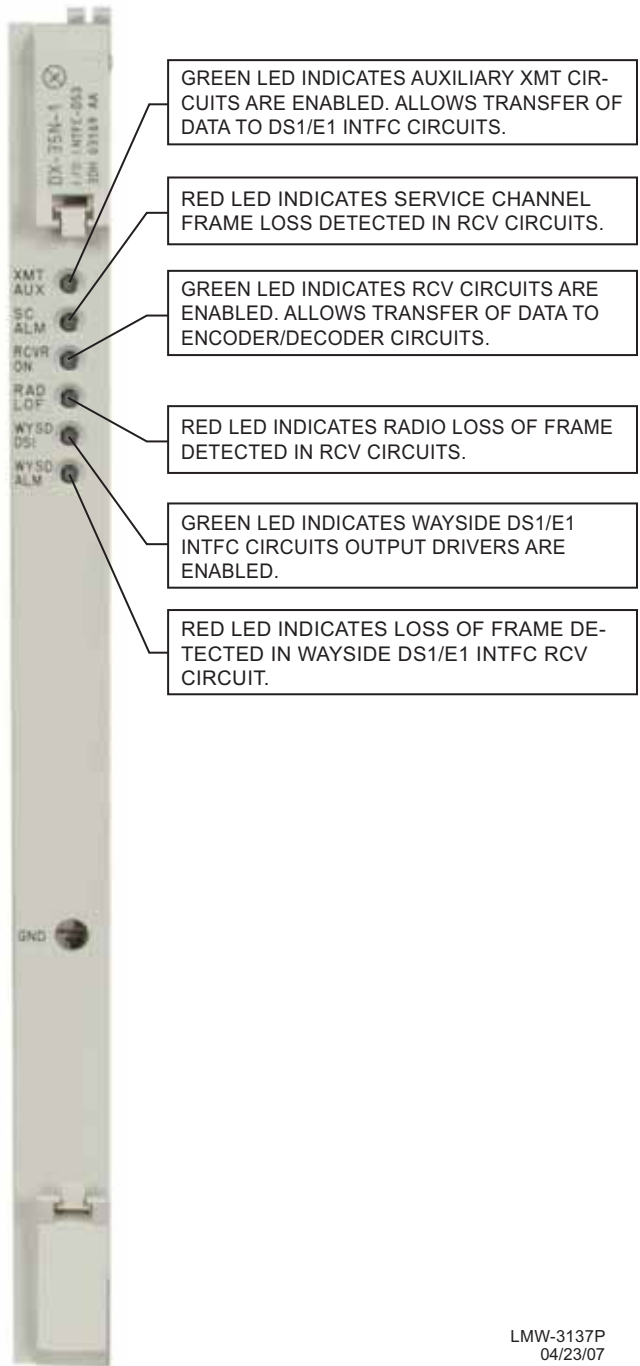
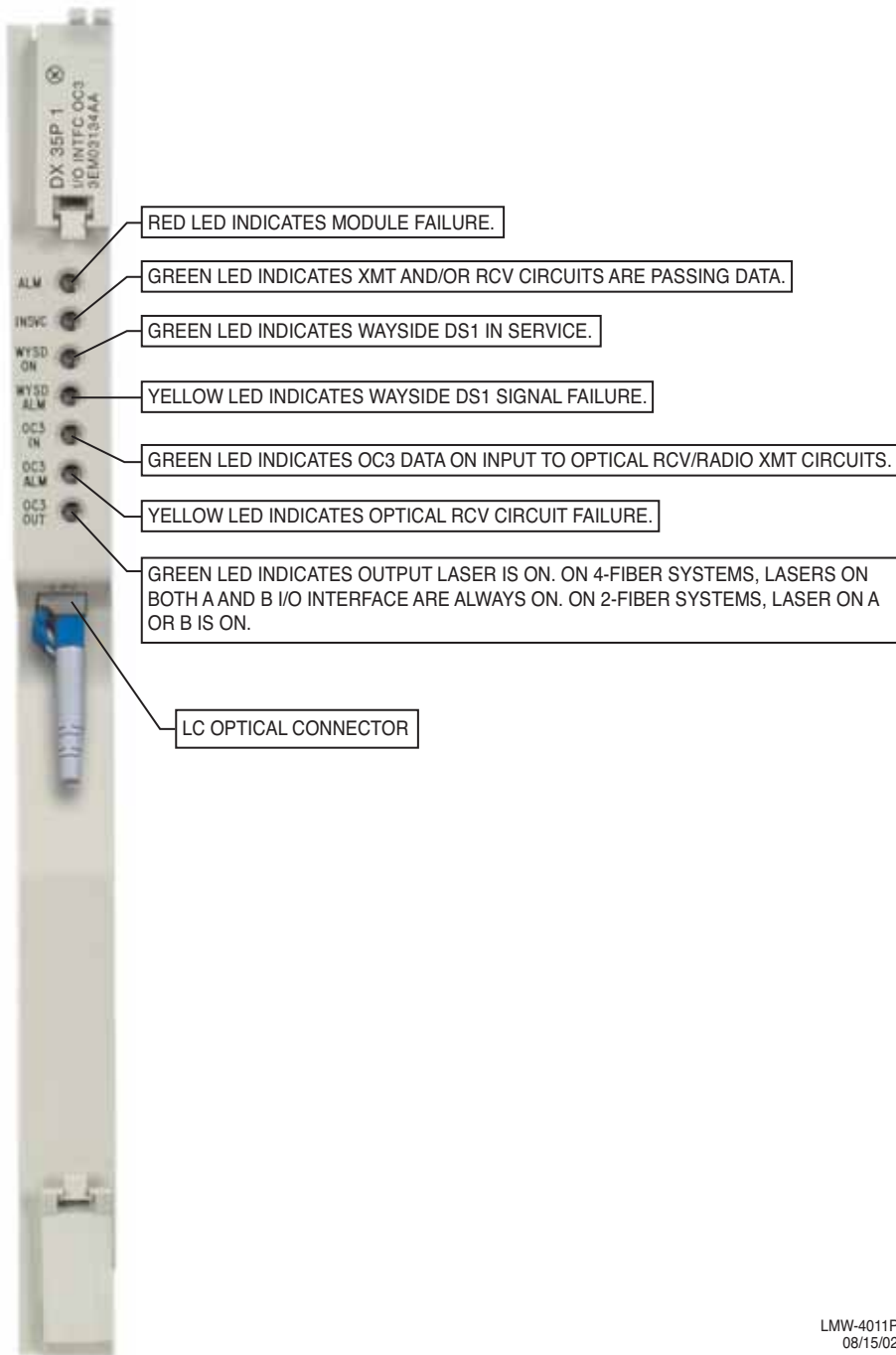

Figure 2-10 DX-35N DS3 I/O Interface Controls and Indicators



LMW-4011P  
08/15/02

Figure 2-11 DX-35P OC3 I/O Interface Controls and Indicators

DX-35R-2 (DX-35R-1 is not shown).

**Note**

*Both the Ethernet and optical ports can be connected for backup protection. Only one port is active. When both are connected, the optical port has priority over the Ethernet port and will remain the active port unless a failure occurs.*

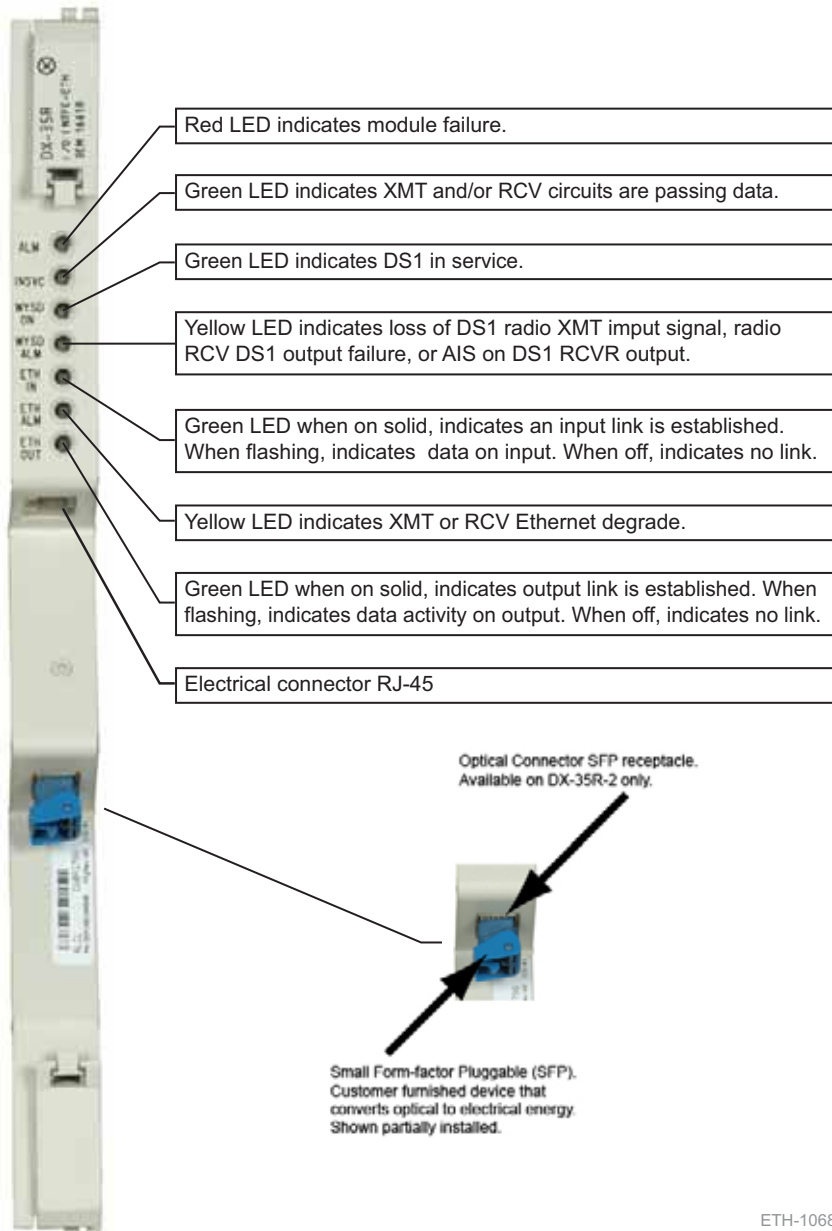

ETH-1068  
07/23/07

Figure 2-12 DX-35R/S ETH I/O Interface Controls and Indicators

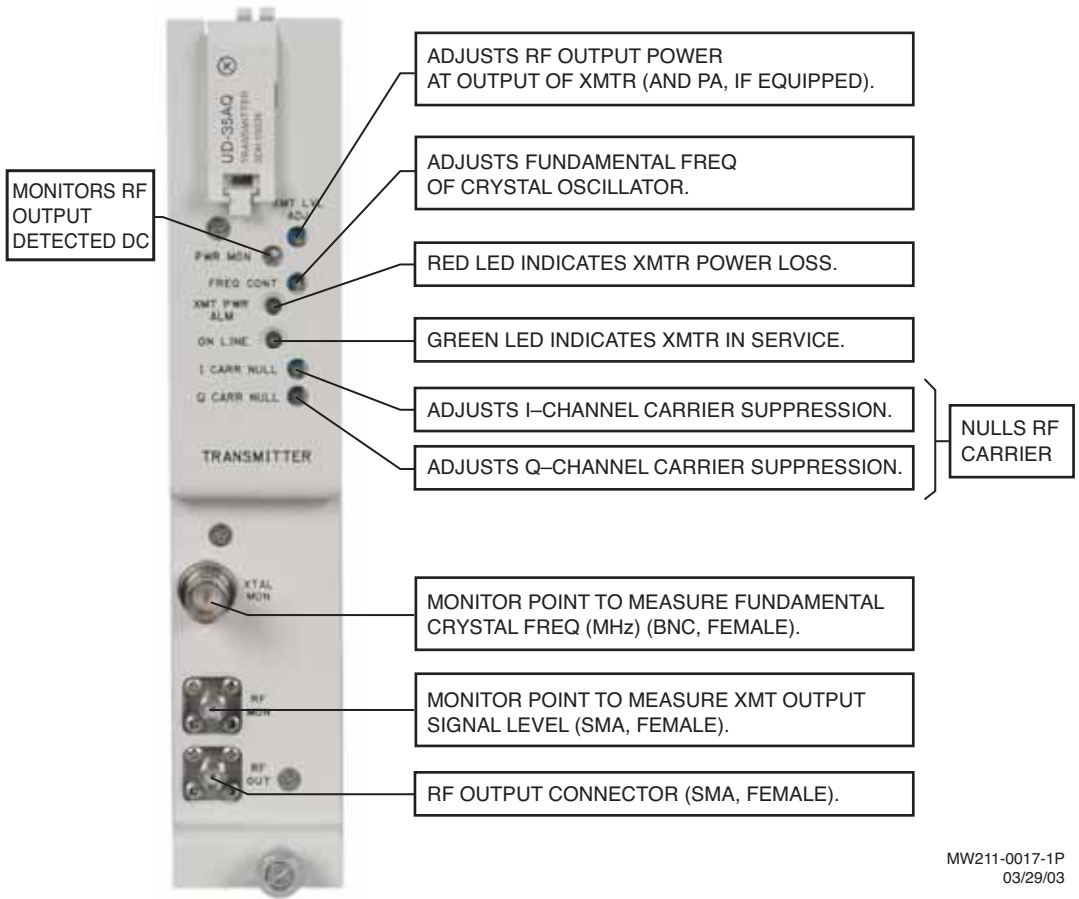

MW211-0017-1P  
03/29/03

Figure 2-13 UD-35() Transmitter Controls, Indicators, Test Points, and Connectors



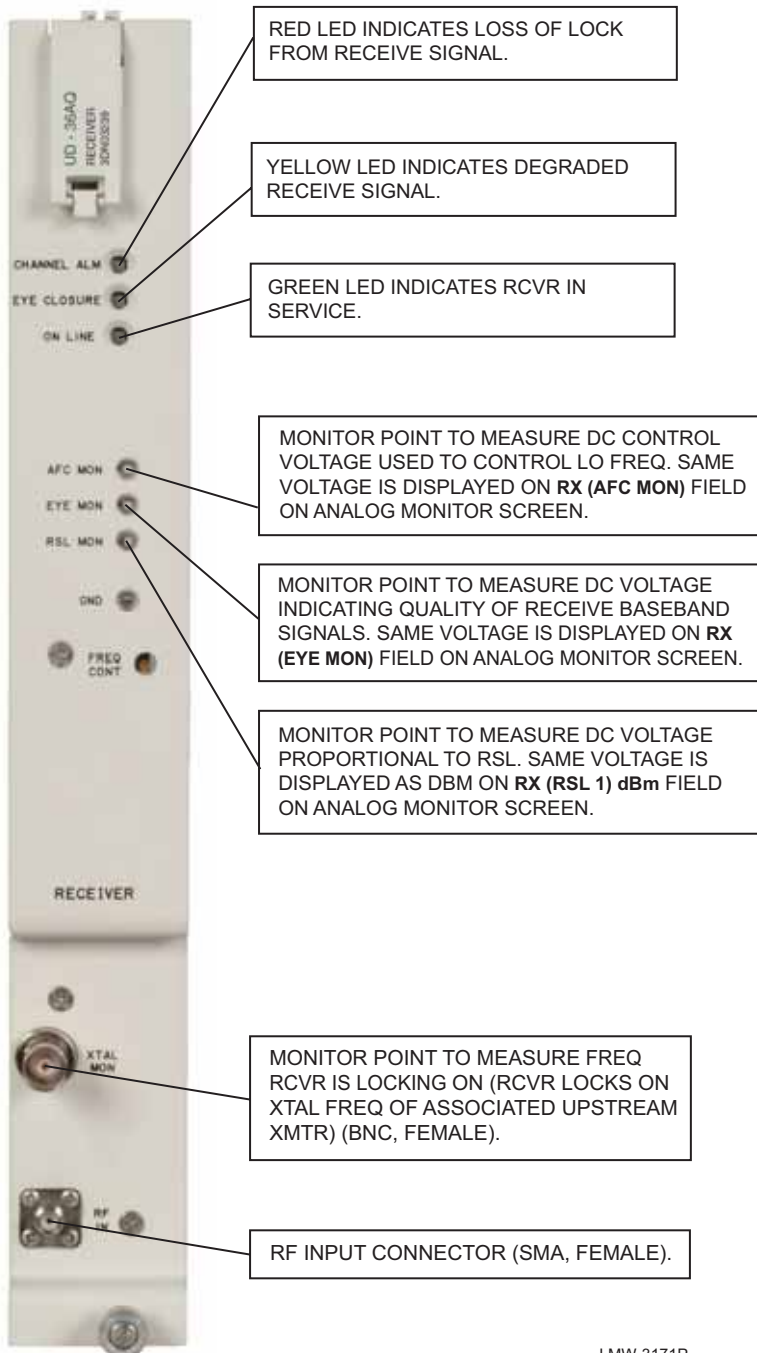

LMW-3171P  
06/12/04

Figure 2-14 UD-36() DS1/E1/DS3/OC3 Single Receiver Controls, Indicators, Test Points, and Connectors



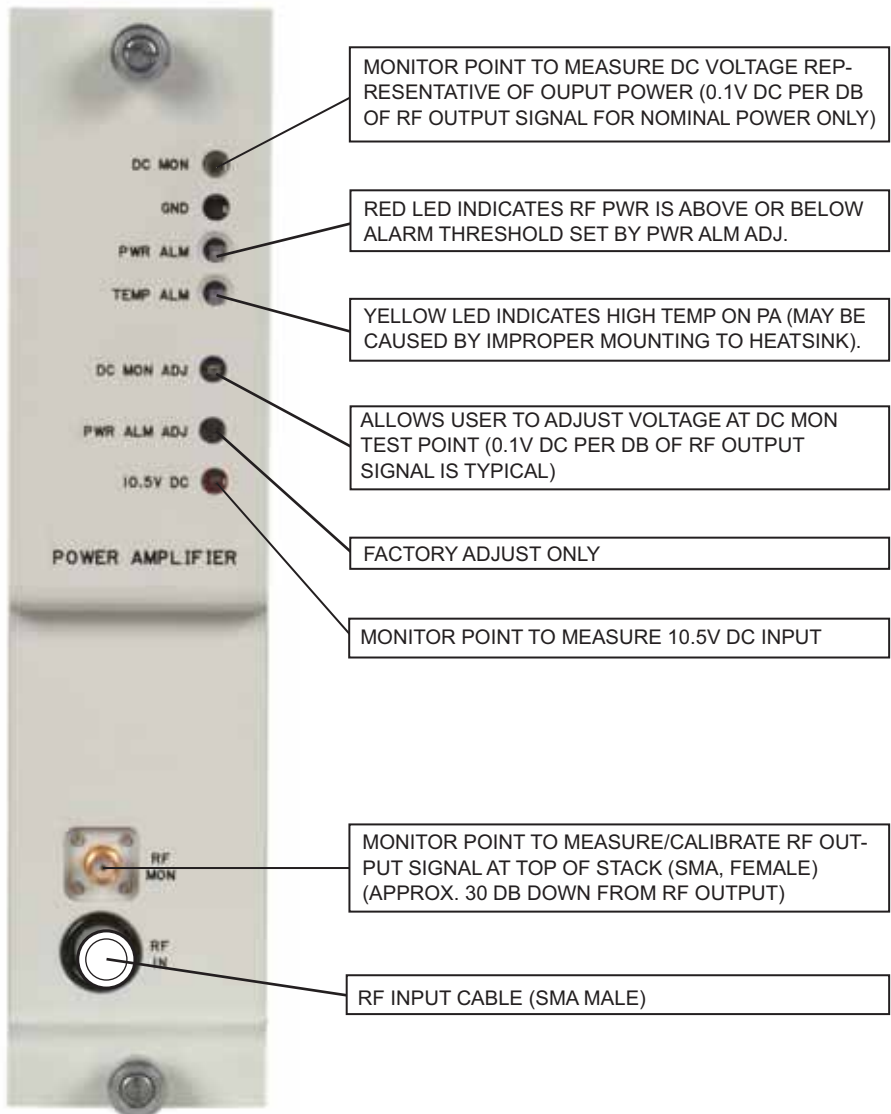

MW211-0038-1P  
04/29/03

Figure 2-16 UD-510 Power Amplifier Controls, Indicators, Test Points, and Connectors

### FRONT VIEW

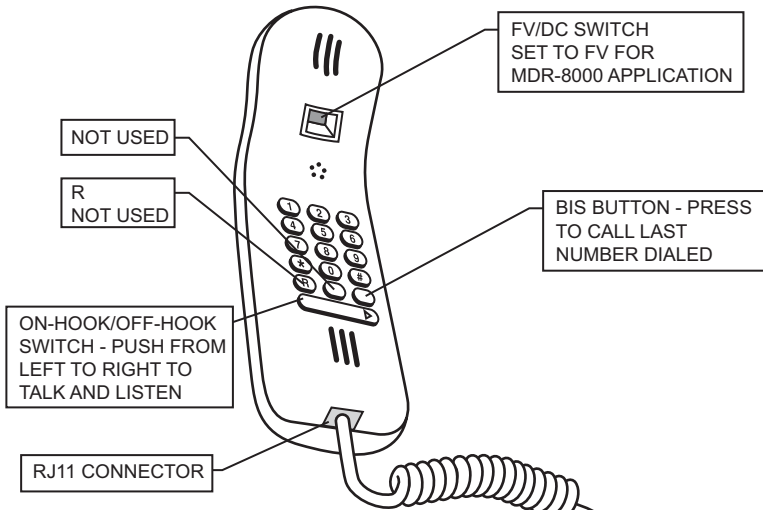

### REAR VIEW

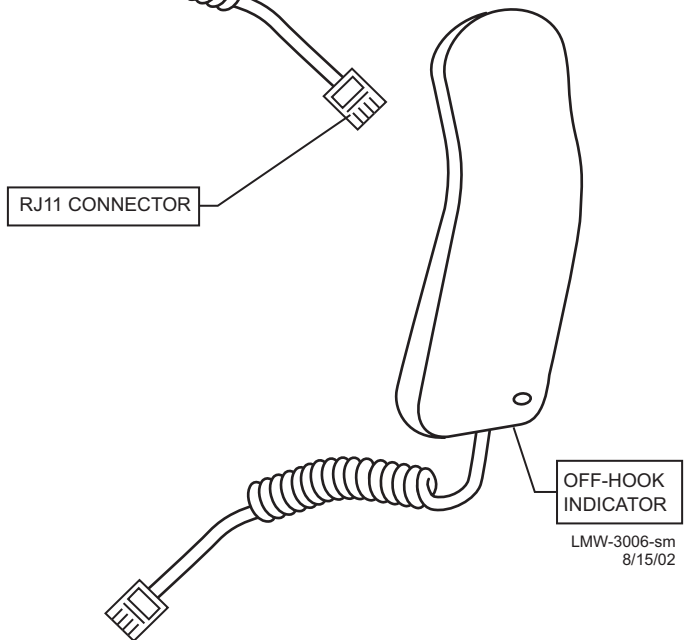

LMW-3006-sm  
8/15/02

Figure 2-17 Handset Controls, Indicators, Test Points, and Connectors

### Note

*The information contained in this section is a summary of the section with the same title, but not the same section number, on the enclosed CD. "Refer to CD" is used throughout this section to refer the reader to the detail information on the CD. Go to this section on the CD for interactive links to the detail information referred to in this section.*

## 3 INTERCONNECT

### 3.1 SECTION INTRODUCTION

This section gives the location and describes strapping, power connections, signal connections, status and alarm connections, and service channel connections for the MDR-8000 hot-standby shelf. Refer to CD for similar installation information for the Compact radios.

### 3.2 POWER CABLE CONNECTION

See Figure 3-1 for power cable assembly installation procedures. The MDR-8000 is internally wired to accept 20.5 to 60 V dc input power with positive or negative ground. To protect maintenance personnel from lightning strikes, the ground system must be integrated by bonding station ground and dc battery return together. The dc power connectors J1 and J2 are located on the rear of the back panel. Install power cables as shown.



***Short circuiting low-voltage, low-impedance dc circuits can cause arcing that may result in burns or eye injury. Remove rings, watches, and other metal jewelry while working with primary circuits. Exercise caution to avoid shorting input power terminals.***



***To protect maintenance personnel from antenna tower lightning strikes, the ground system must be integrated by bonding frame ground and dc battery return together.***

**WARNING**

*Possibility of  
Damage  
to Equipment*

**Do not apply battery power until it is determined that A and B battery cables with isolated returns and power cables are wired correctly. With power applied, reverse polarity on wiring (+batt wired to -batt pin on connector) can cause power supply fuse to blow.**

**Note**

*Grounding of pole, antenna, customer interfaces, and all entrances to the building interior shall meet local electrical code and standard business practices.*

1. DETERMINE IF INSTALLATION REQUIRES POS OR NEG GND.
2. INSTALL BATT, GND, AND JUMPER WIRES ON PWR CABLE ASSEMBLY.
3. CONNECT PWR CABLE ASSEMBLY TO J1 (AND J2 IF HOT-STBY).
4. CONNECT RACK GND AND CHASSIS GND.
5. CONNECT BATT.

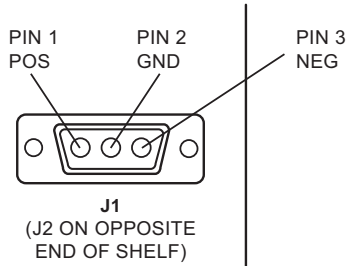

REAR VIEW OF SHELF

**WARNING**  
Possibility of  
Damage  
To Equipment

**To prevent connector damage and improper wiring, ensure power cable mating connector is properly oriented and aligned with shelf connector before attempting to seat connectors.**

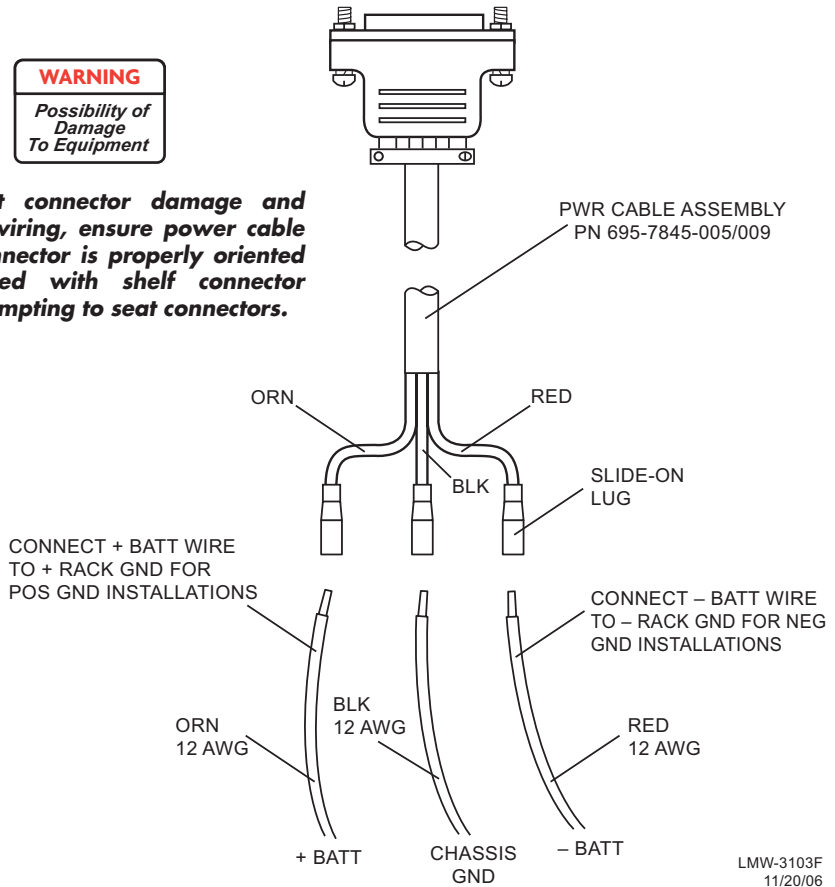

LMW-3103F  
11/20/06

Figure 3-1 Power Cable Connection

### 3.3 PDU STRAPPING AND CONNECTIONS

See Figure 3-2 for strapping and connections for PDU PN 3EM13317AA. For strapping and connections for PDU PN 695-6200, Refer to CD.

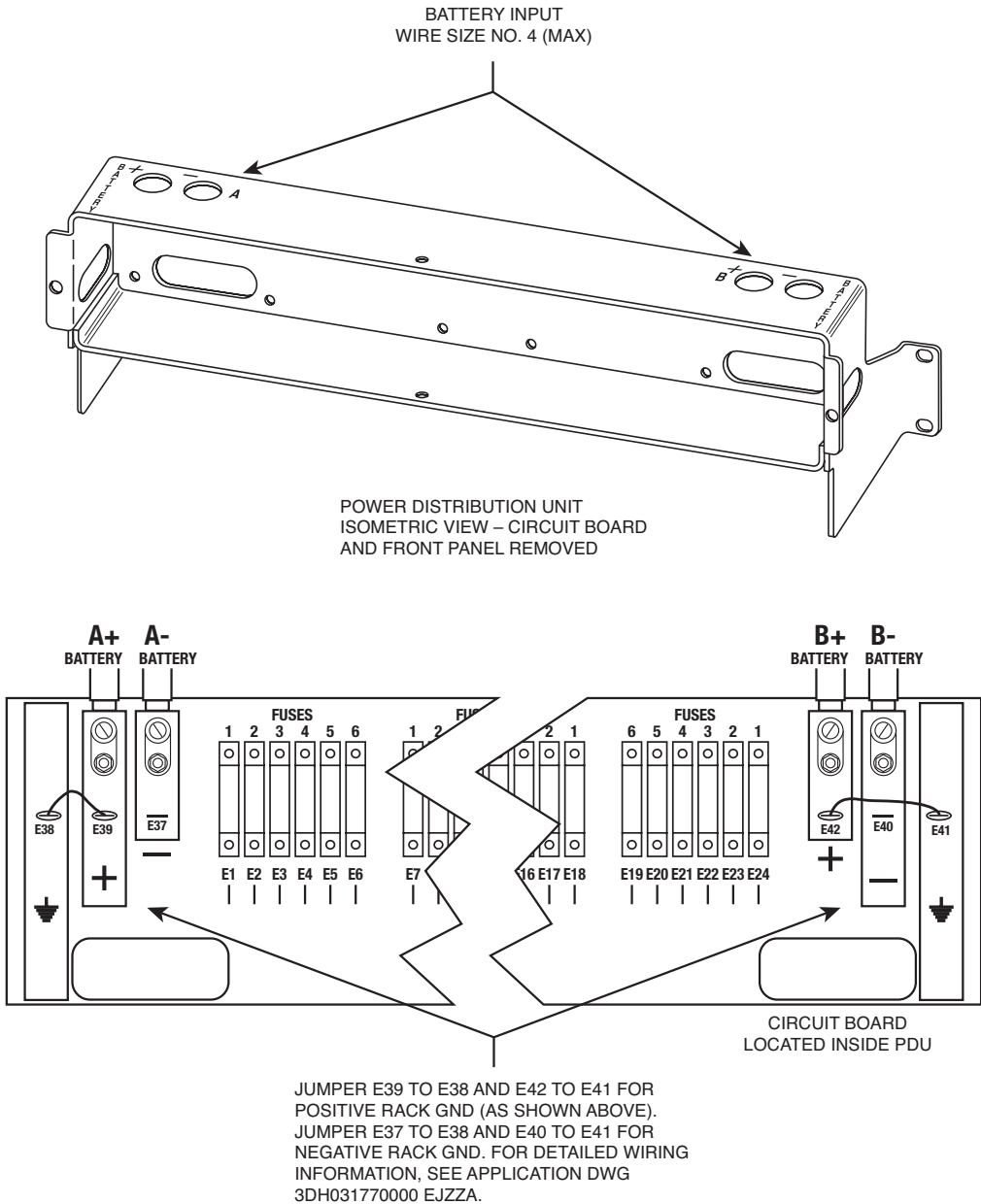

PN 3EM13317AA

LMW-9001  
10/10/05

Figure 3-2 PDU Strapping and Connections



### 3.4 SHELF/RACK ALARM CONNECTION

The PDU, PN 3EM13317AA, has a blown fuse alarm visual indicator and a Form C relay alarm output (J4, J5, and J6) for connection to customer alarm equipment.

An optional Fuse and Shelf alarm plug-in assembly is available to provide shelf alarm connections requiring Form C relays. The alarm inputs (major and minor) must be hard wired to J3 on the PDU. The alarms are provided on alarm connector J305 pin 24 (major/visual alarm) and pin 50 (minor/audible alarm) of each shelf. A wire-wrap adapter (PN 695-4171-002) for connector J305 is available. Insulated 22-gauge solid copper wire is recommended for connecting to the wire-wrap adapter and also to J3 on the PDU. Alarm outputs are transmitted to customer equipment via Form C relay outputs (J4, J5, J6, relays 1 through 8). This option also includes the blown fuse alarm indicator and Form C relay alarm output (J4, J5, and J6 – relay 9). See Figure 3-3 for shelf to PDU alarm wiring for PDU PN 3EM13317AA. For shelf to PDU alarm wiring for PDU PN 695-6200, Refer to CD.

### 3.5 MDR-8000 SYNCHRONOUS REPEATER CONNECTIONS

The following paragraphs describe the cabling and limitations involved with carrying MDR-8000 service channel information across two (2) back-to-back radio terminals at a repeater site. In this document, the term synchronous indicates that the clocks of the two radios are locked together. **Synchronous, in this document, has absolutely nothing to do with whether or not the radios are transporting synchronous (SONET or SDH) data.**

Where allowed, only two radios can be tied together synchronously. In scenarios where there are three (3) radios (or some other odd number of radios), the third radio must be clocked independently or asynchronously from the first two.

#### Note

*Multiple service channel functions [i.e., orderwire, fault alarm, RS-232 and extended link monitor channel (ELMC) data] can be carried across a common synchronous repeater cable. When asynchronous connections are required between radios, each service channel function (i.e., orderwire, fault alarm, ELMC, etc.) must be carried across its own independent cable.*

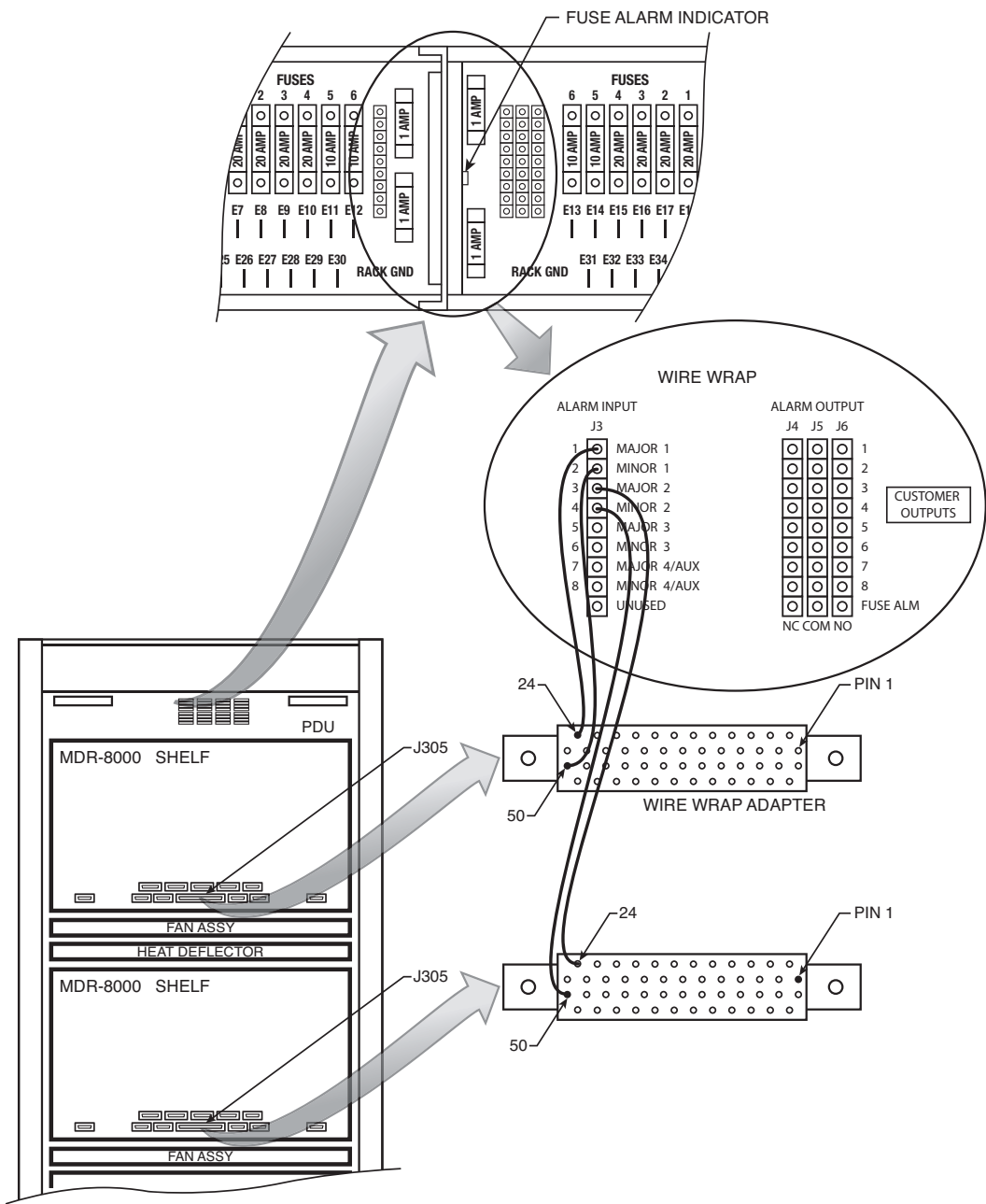

LMW-8057F  
04/23/03

Figure 3-3 Shelf Alarm Wiring PDU (3EM13317AA)

### 3.5.1 Low Capacity DS1 Radios

The MDR-8000 synchronous repeater connection J314 in a low capacity DS1 radio is used to pass orderwire, fault alarm, ELMC, **and DS1** traffic between two (2) back-to-back low capacity terminals over a common cable. The framing structure of the X/Y rail pairs being passed over the synchronous repeater cable are the same for radios equipped to transport 4, 8, 12, or 16 DS1s but unique for 2 DS1. Because of the difference in frame structure, **a radio configured to transport 2 DS1 radio can only be connected via the J314 synchronous repeater cable to another 2 DS1 radio.** There are no restrictions with any combinations of capacity above 2 DS1. Connections for the service channels from a radio configured for 2 DS1 to a radio configured for 4, 8, 12, or 16 DS1s must be interconnected asynchronously.

#### Note

*The DS1 version of the radio is the only one that can pass its “through” traffic across the synchronous repeater cable.*

#### Note

*The E1 version of the radio uses all of the same components as the DS1, with the exception of the capacity keys and LBOs. Therefore, its operation is virtually identical to the DS1. However, an E1 radio cannot be configured as a synchronous repeater with a DS1 radio.*

### 3.5.2 High Capacity DS3 Radios

The MDR-8000 synchronous repeater connection J401 in a high capacity DS3 radio is used to pass orderwire, fault alarm and ELMC data between two (2) back-to-back high capacity terminals over a common cable. The frame structure of the data transported over the synchronous repeater cable on radios configured to transport 1 or 3 DS3 is the same for both capacities. Repeater connections using J401 between a radio configured for 1 DS3 and a radio configured for 3 DS3s is allowed. **Repeater connections between a radio configured for DS1 or OC3 capacities to a radio configured for DS3 capacities using J314 to J401 or J203 to J401 are not allowed.** Connections between a radio configured for DS1, E1, or OC3 capacities and a radio configured for DS3 capacities must be interconnected asynchronously.

### 3.5.3 High Capacity OC3 Radios

The MDR-8000s synchronous repeater connection J203 in a high capacity OC3 radio is used to pass orderwire, fault alarm and ELMC data between two (2) back-to-back high capacity terminals over a common cable. The orderwire, fault alarm and ELMC data is multiplexed together into a standard T1. The multiplexed T1 data is the same for either version of the OC3 radio, 10 MHz/1STS-1 or 30 MHz/3STS-1 payload. Therefore, repeater connections using J203 between a radio configured for 1 STS-1 and a radio configured for 3 STS-1s is allowed. Repeater connections between an OC3 version of the radio and a non-OC3 version of the radio using J203 to J314 or J203 to J401 are not allowed. Connections between a radio configured for OC3 capacities and a radio configured for DS1 or DS3 capacities must be interconnected asynchronously.

**Note**

*Having the radio overhead multiplexed together into a standard T1 also allows the overhead to be transported over non-Alcatel radio facilities (i.e., channel banks, fiber optic terminals, or no-Alcatel radio equipment). This feature is extremely useful in SONET rings where part of the ring will be MDR-8000s OC3 radio and part will be SONET fiber equipment.*

### 3.5.4 MDR-8000 Synchronous Repeater Compatibility Matrix

Table 3-1 lists the combinations of MDR-8000 capacities that support the use of the synchronous repeater cable.

**Table 3-1 Synchronous Repeater Compatibility**

Radio #1 Capacity	Radio #2 Capacity								
	DS1					DS3		OC3	
	2	4	8	12	16	1	3	10 MHz	30 MHz
2 DS1	X								
4 DS1		X	X	X	X				
8 DS1		X	X	X	X				
12 DS1		X	X	X	X				
16 DS1		X	X	X	X				
1 DS3						X	X		
3 DS3						X	X		
OC3 (10 MHz)								X	X
OC3 (30 MHz)								X	X

X denotes allowable combinations of use

### 3.5.5 MDR-8000 Synchronous Repeater Cables

Refer to Table 3-2.

**Notes:**

- 1 For both High and Low capacity applications, refer to drawing number 3DH031770000EJZZA for the specific cable connections.
- 2 The MDR-8000 Synchronous Repeater Cable part number is the same for both the DS1 and D3 versions of the radio. Refer to drawing number 3DH031770000BJZZA for cable dash numbers and lengths.

- 3 The MDR-8000 Synchronous repeater Cable for the OC3 version of the radio uses the same part number as the ELMC cable.

Table 3-2 Synchronous Repeater Cables

Capacity	Part Number	Designation	No. of Pins
DS1	695-7836-001/005	J314	50
DS3	695-7836-001/005	J401	50
OC3	695-4125-007/013	J203	9

### 3.6 DS1 CONNECTIONS (J303 IN AND J304 OUT)

Recommended connectorized cable assembly – PN 695-7806-001 through -005 (22 AWG 16 pair shielded, jacketed cable with 37-pin D-type connector on one end). See Figure 3-4 for shelf connector location and pinout. Refer to Table 3-3 for mating cable wiring and color code.

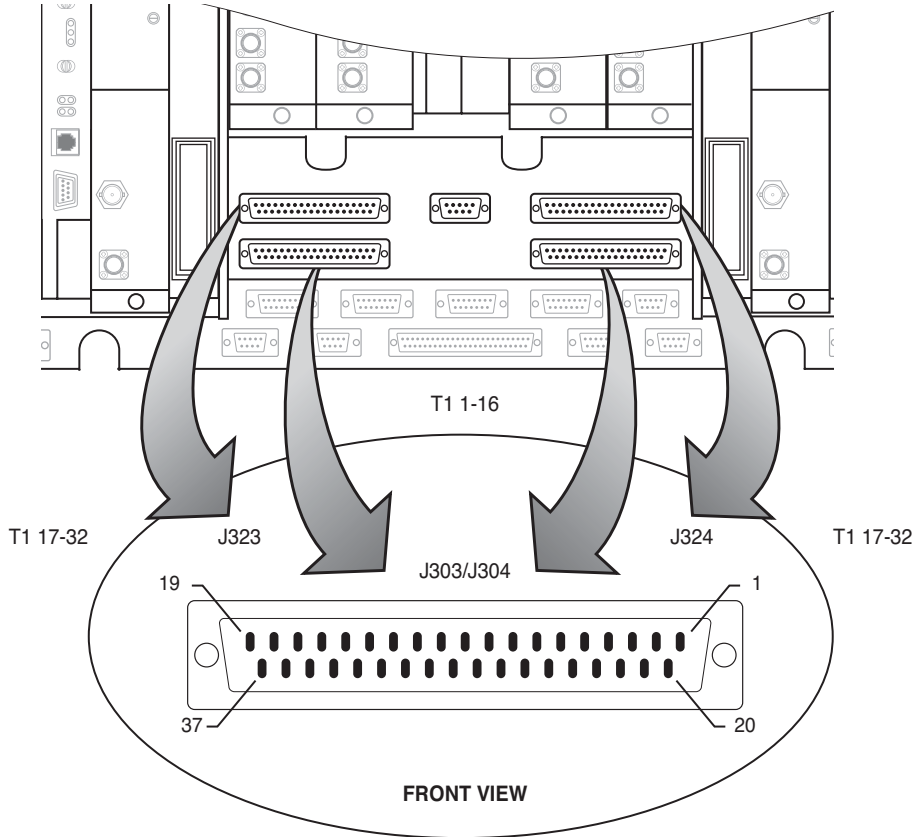

LMW-9037F  
07/03/07

Figure 3-4 DS1 Connectors Location and Pinout

**Table 3-3 DS1 IN J303 and DS1 OUT J304 Mating Cable**

CONNECTOR PIN NUMBER	WIRE COLOR	SIGNAL NAME	CABLE PAIR NUMBER
1	WHITE-BLUE	CHAN 1 TIP	1
20	BLUE-WHITE	CHAN 1 RING	
2	WHITE-ORANGE	CHAN 2 TIP	2
21	ORANGE-WHITE	CHAN 2 RING	
3	WHITE-GREEN	CHAN 3 TIP	3
22	GREEN-WHITE	CHAN 3 RING	
4	WHITE-BROWN	CHAN 4 TIP	4
23	BROWN-WHITE	CHAN 4 RING	
5	WHITE-SLATE	CHAN 5 TIP	5
24	SLATE-WHITE	CHAN 5 RING	
6	RED-BLUE	CHAN 6 TIP	6
25	BLUE-RED	CHAN 6 RING	
7	RED-ORANGE	CHAN 7 TIP	7
26	ORANGE-RED	CHAN 7 RING	
8	RED-GREEN	CHAN 8 TIP	8
27	GREEN-RED	CHAN 8 RING	
9	RED-BROWN	CHAN 9 TIP	9
28	BROWN-RED	CHAN 9 RING	
10	RED-SLATE	CHAN 10 TIP	10
29	SLATE-RED	CHAN 10 RING	
11	BLACK-BLUE	CHAN 11 TIP	11
30	BLUE-BLACK	CHAN 11 RING	
12	BLACK-ORANGE	CHAN 12 TIP	12
31	ORANGE-BLACK	CHAN 12 RING	
13	BLACK-GREEN	CHAN 13 TIP	13
32	GREEN-BLACK	CHAN 13 RING	
14	BLACK-BROWN	CHAN 14 TIP	14
33	BROWN-BLACK	CHAN 14 RING	
15	BLACK-SLATE	CHAN 15 TIP	15
34	SLATE-BLACK	CHAN 15 RING	
16	YELLOW-BLUE	CHAN 16 TIP	16
35	BLUE-YELLOW	CHAN 16 RING	

### 3.7 DS1 REPEATER (J314 ON ONE SHELF TO J314 ON SECOND SHELF)

**Note**

*The DS1 repeater cable carries clocks, DS1 data, and overhead for two directions. If the 314 cable is not used, the embedded data in the overhead must be cabled individually. In this case, individual cables must be run for MCS-11, audio, RS-232, and ELMC.*

Recommended connectorized cable assembly – PN 695-7836-001/005 (25 pair shielded cable with 50 pin Amp connectors) (SCSI). See Figure 3-5 for shelf connector location and pinout. Refer to Refer to CD for mating cable wiring and color code.

**Note**

*Use repeater cables for cabling repeater shelf 1 to repeater shelf 2 (east-bound/westbound data/clock)*

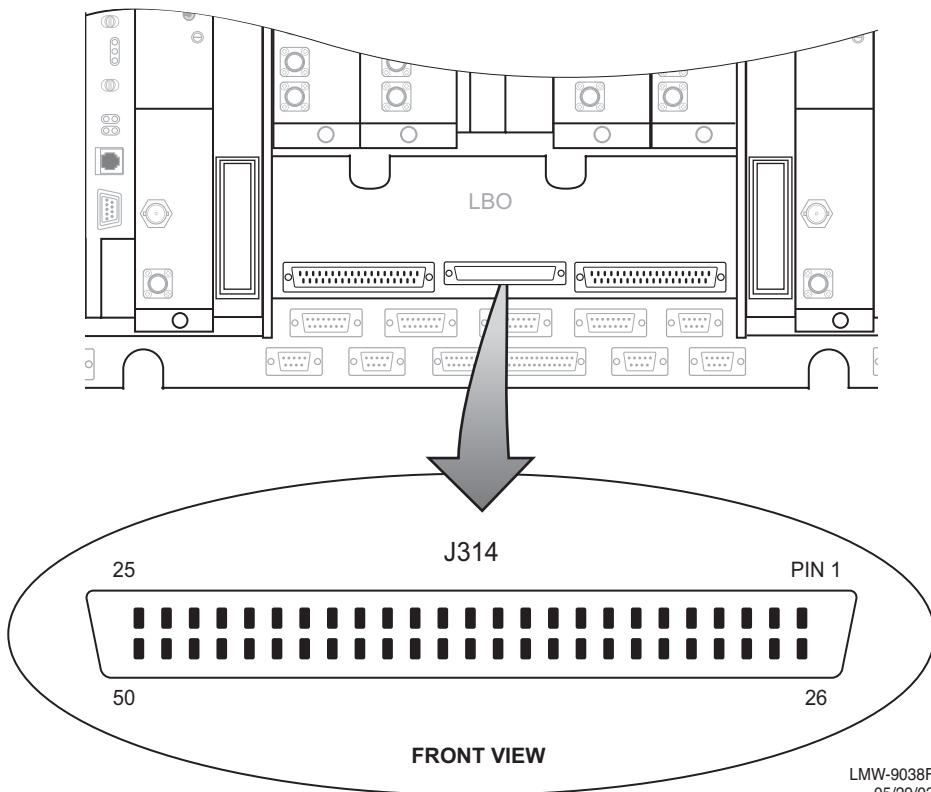

LMW-9038F  
05/29/03

Figure 3-5 Connector J314 Location – DS1 LBO

### 3.8 DS3 LBO STRAPPING AND CONNECTIONS

The DS3 LBO compensates for the distance to the cross-connect for DS3 and wayside DS1 outputs. See Figure 3-6 for strap locations. Refer to Table 3-4 for strapping requirements.

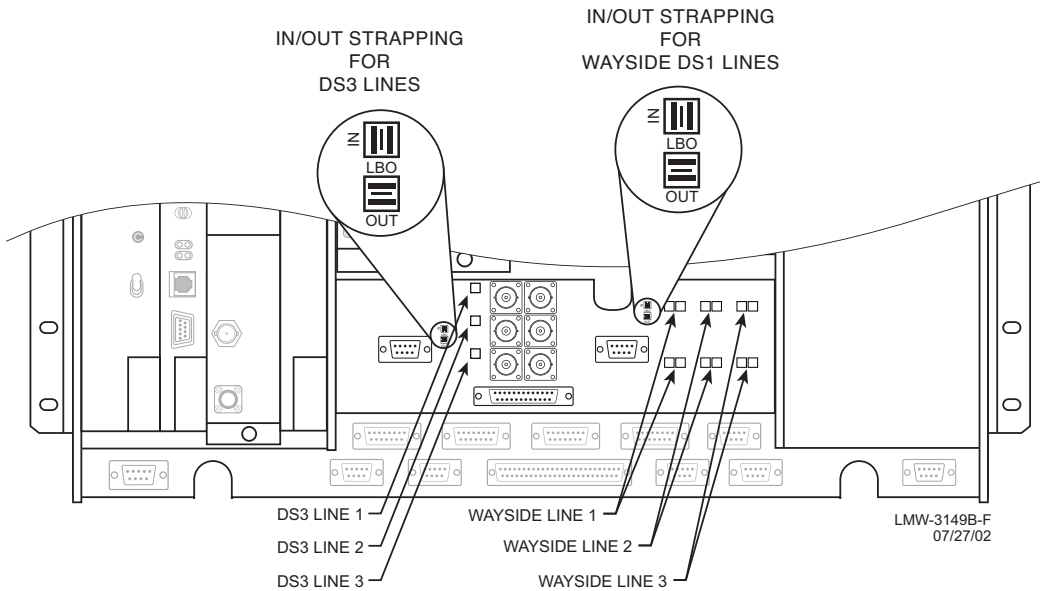

Figure 3-6 DS3 LBO Strapping

**Note**

*When using 734 or equivalent type DS3 cable, 450 feet is the maximum length to the cross-connect. The maximum length with the LBO strapped IN is 225 feet.*

Table 3-4 DS3 LBO Strapping

OUTPUTS	DISTANCE TO CROSS-CONNECT	STRAPPING
DS3	0 to 225 ft	In
DS3	226 to 450 ft	Out
Wayside DS1	0 to 330 ft	In
Wayside DS1	331 to 660 ft	Out



### 3.9 DS3 LBO DS3 BNC CONNECTIONS (J21 THROUGH J26)

BNC removal tool (PN 359-0092-010) is required for installing and removing BNC cables.

Recommended connectorized cable assembly for all applications except repeaters, PN 632-4429-096/180 (8/15 ft RG-59B/U coax cable with straight male BNC connector on one end and right angle male BNC connector on other end). For repeater applications, recommend PN 632-4288-096/180 (8/15 ft RG-59B/U coax cable with straight male BNC connector on each end). See Figure 3-5 for locations. Refer to Table 3-5 for connections.

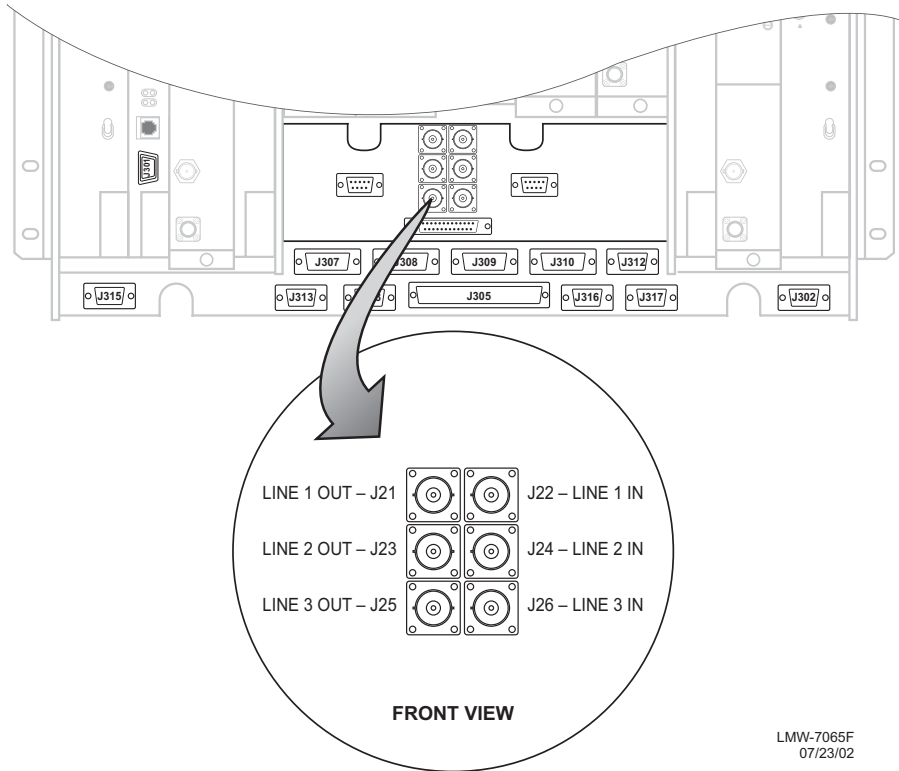

LMW-7065F  
07/23/02

Figure 3-7 DS3 LBO DS3 Connectors Location

Table 3-5 DS3 LBO Connectors

DS3 INPUTS		DS3 OUTPUTS	
FUNCTION	BNC CONNECTOR	FUNCTION	BNC CONNECTOR
DS3 LINE 1	J22	DS3 LINE 1	J21
DS3 LINE 2	J24	DS3 LINE 2	J23
DS3 LINE 3	J26	DS3 LINE 3	J25

### 3.10 DS3 LBO WAYSIDE DS1 CONNECTIONS (J201 IN AND J202 OUT)

Wayside DS1 is an option in the MDR-8000 DS3 radios. This option provides 1 DS1 for each equipped DS3. To activate the wayside channels requires a small circuit board, called ELMC option key, that plugs onto the controller module. The protection of the wayside channels follows the protection scheme of the radio configuration. In other words, if the radio is hot-standby the wayside channels are hot-standby. The channels are point to point just as is the payload traffic. They are independent of the traffic and reside in the overhead channels. The advantage of the wayside DS1 is the ability to drop 1 to 3 DS1's without having to add a 1:3 muldem to access the traffic. Refer to Table 3-6 for ELMC option key requirements for remote monitoring/controlling wayside DS1s.

Table 3-6 Wayside DS1 Performance and Control

	PART NO.	FUNCTION
ELMC Option Key	695-5647-019	Required to enable WS DS1 lines for remote wayside DS1status
ELMC Option Key	695-5647-020	Required to enable WS DS1 lines for remote wayside DS1status + remote provisioning and downloading

#### 3.10.1 Wayside DS1 Terminal

Recommended connectorized cable assembly – PN 695-4125-041 (26 AWG 5 pair shielded, jacketed cable with 9-pin D-type connector on one end. See Figure 3-9 for shelf connector location and pinout. Refer to Table 3-7 for mating cable wiring and color code.

#### 3.10.2 Wayside DS1 Repeater

Recommended connectorized cable assembly – PN 695-4125-051 (26 AWG 5 pair shielded, jacketed cable with 9-pin D-type connector on each end). See Figure 3-8 for Wayside DS1 repeater interconnect.

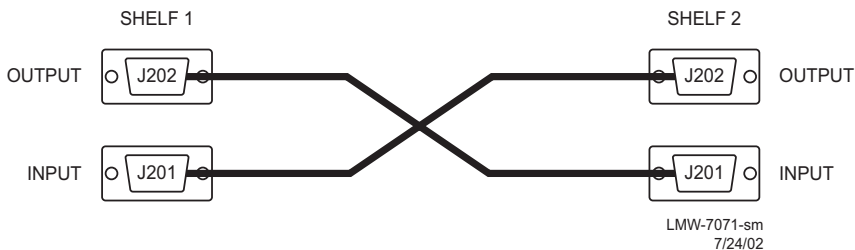

Figure 3-8 Wayside DS1 Repeater Interconnect

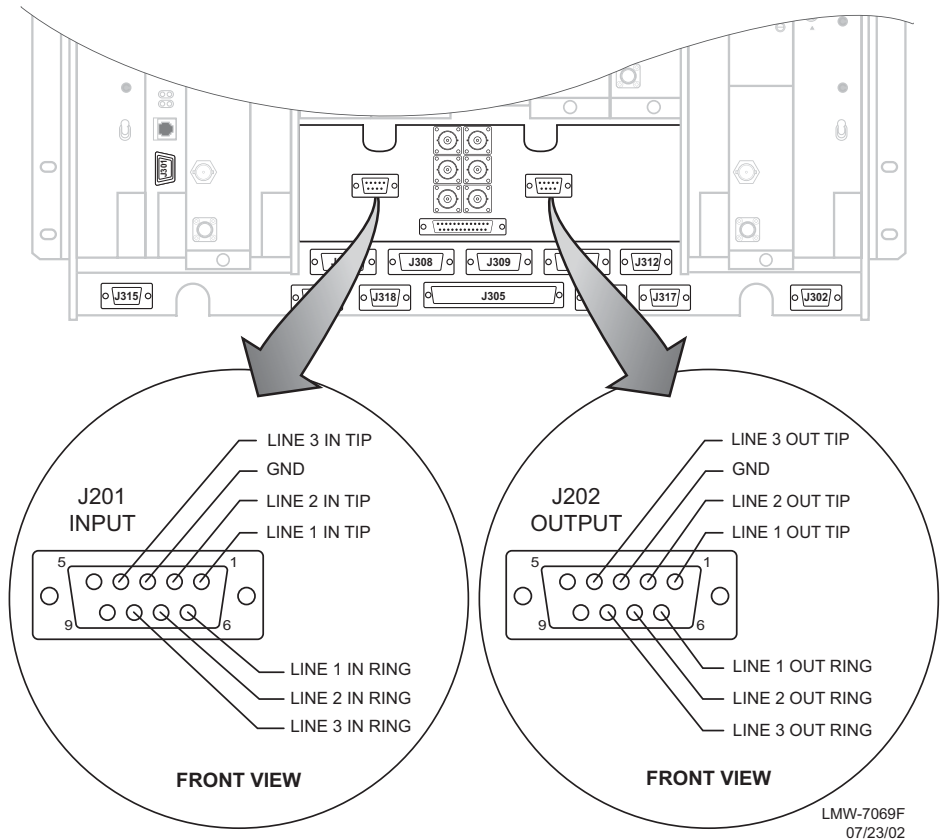

Figure 3-9 DS3 LBO Wayside DS1 Connectors Location and Pinout

Table 3-7 Wayside DS1 Mating Cable – DS3 LBO

J201 (INPUTS)			202 (OUTPUTS)		
FUNCTION	END 1	WIRE COLOR	WIRE COLOR	END 2	FUNCTION
LINE 1 TIP IN	01	BLACK	BLACK	01	LINE 1 TIP OUT
LINE 1 RING IN	06	RED	RED	06	LINE 1 RING OUT
LINE 2 TIP IN	02	BLACK	BLACK	02	LINE 2 TIP OUT
LINE 2 RING IN	07	WHITE	WHITE	07	LINE 2 RING OUT
LINE 3 TIP IN	04	BLACK	BLACK	04	LINE 3 TIP OUT
LINE 3 RING IN	08	GREEN	GREEN	08	LINE 3 RING OUT
NOT USED	05	BLACK	BLACK	05	NOT USED
NOT USED	09	BLUE	BLUE	09	NOT USED
GND	03	BLACK	GND	03	NOT USED
NOT USED	10	YELLOW	YELLOW	10	NOT USED

### 3.11 DS3 REPEATER (J401 ON ONE SHELF TO J401 ON SECOND SHELF)

**Note**

*The DS3 repeater cable carries clocks, data, and overhead for two directions. It does not carry DS3 or wayside DS1 traffic. DS3 and wayside DS1 cables must be run separately. If the 401 cable is not used, the embedded data in the overhead must be cabled individually. In this case, individual cables must be run for MCS-11, audio, RS-232, and ELMC.*

Recommended connectorized cable assembly – PN 695-7836-001/005 (25 pair shielded cable with 50 pin Amp connectors) (SCSI). See Figure 3-10 for shelf connector location and pinout. Refer to CD for mating cable wiring and color code.

**Note**

*Use repeater cables for cabling repeater shelf 1 to repeater shelf 2 (east-bound/westbound data/clock).*

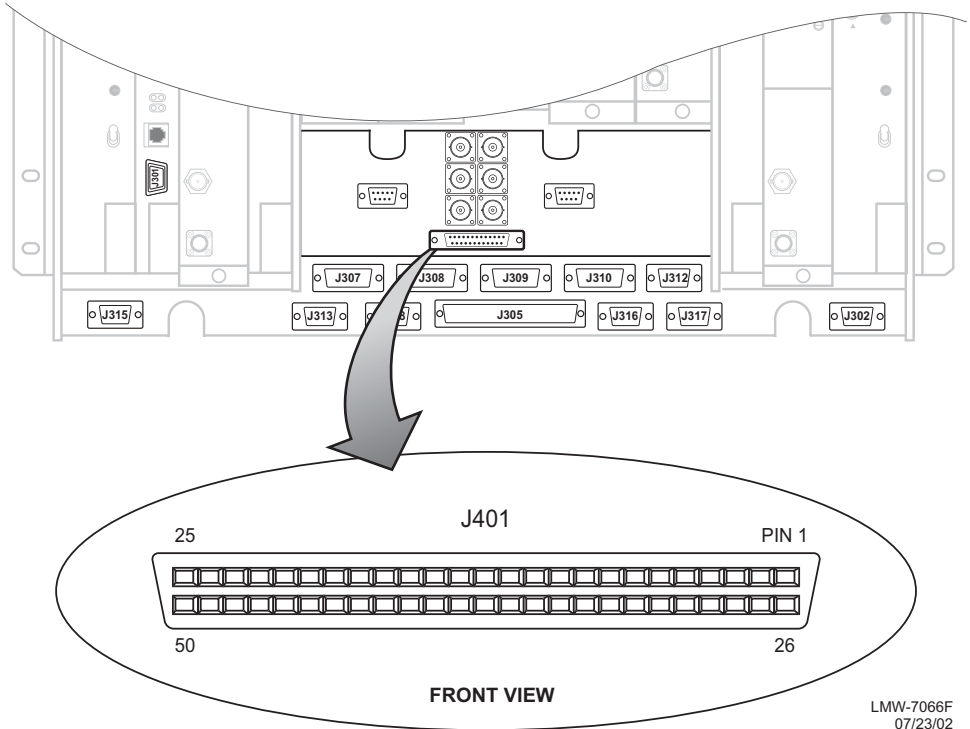

LMW-7066F  
07/23/02

Figure 3-10 Connector J401 Location – DS3 LBO

### 3.12 FIBER OPTIC CABLE CONNECTIONS



*This system normally operates as a Class I Laser Product (no hazard), however during servicing operations, when optical connectors are being connected, disconnected, or handled without dust covers, it is possible to be exposed to Class IIIB laser radiation which can cause eye damage.*



*Fiber optic connectors are delicate and can be damaged easily by dirt or debris on the end of the connector. Keep fiber optic connectors free of dust and debris by cleaning the connector before and after use. Carefully clean the fiber optic connector and cable ends with a cotton swab dipped in alcohol or an alcohol wipe. Keep safety cap on connectors when not in use.*

The Alcatel 2 or 4 fiber management panel (PN 3EM09257AB) and 2x4 fiber management panel (PN 3EM09257AA) connections are described. For other fiber management equipment, refer to the manufacturers instructions. See Figure 3-11 and Figure 3-12 for typical connections. Refer to Table 3-10 for recommended fiber optic jumpers.

**Table 3-8 Fiber Optic Jumpers**

JUMPER TYPE	PART NO.	APPLICATION
FC to LC	3EM07651AA-AK	TERMINAL
SC TO LC	3EM07646AA-AK	TERMINAL
LC TO LC	3EM07641AA-AK	REPEATER

### 3.12.1 2 or 4 Fiber Management Panel

The 2 or 4 fiber management panel provides a direct interface with customers 2 or 4 fiber equipment. The two fibers on a non-standby radio or four fibers on a hot-standby radio connect to the two or four fibers from the customers equipment. The 2 or 4 fiber configuration requires the duplex adapter panel to route the fiber to/from the I/O interface modules. One duplex adapter panel can accommodate two radio shelves. Customer fiber must have SC type connectors

### 3.12.2 2x4 Fiber Switched Management Panel

The 2x4 fiber management panel interfaces the four fibers on a hot-standby shelf with customer's 2-fiber equipment. The 2x4 fiber configuration requires combiner splitter units to route the fiber to/from the I/O interface modules. One combiner/splitter unit per radio shelf is required. The 2x4-fiber management panel has cutouts for two combiner/splitter units and can accommodate two radio shelves.

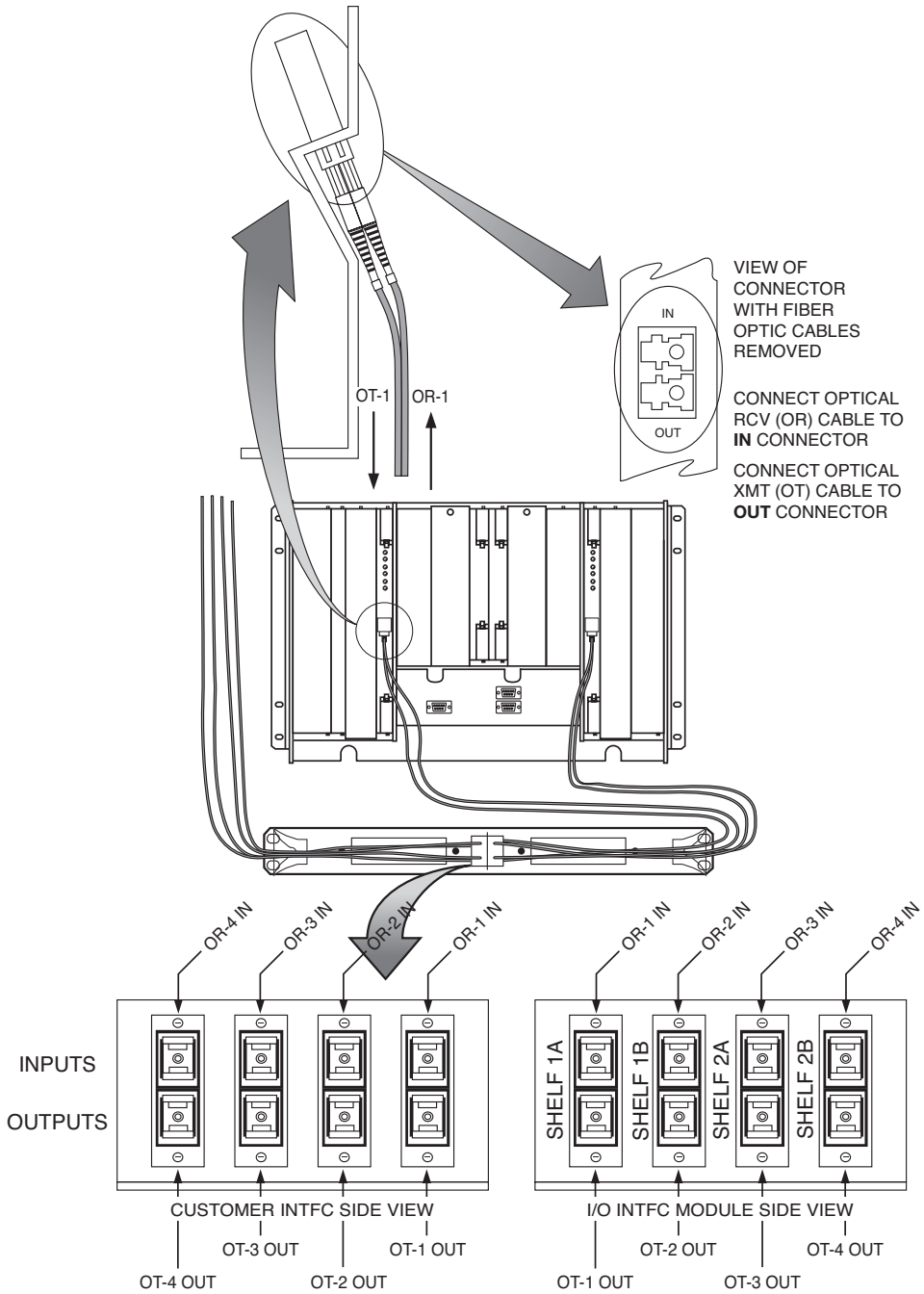

LMW-6038F  
07/22/02

Figure 3-11 2 or 4 Fiber Management Panel



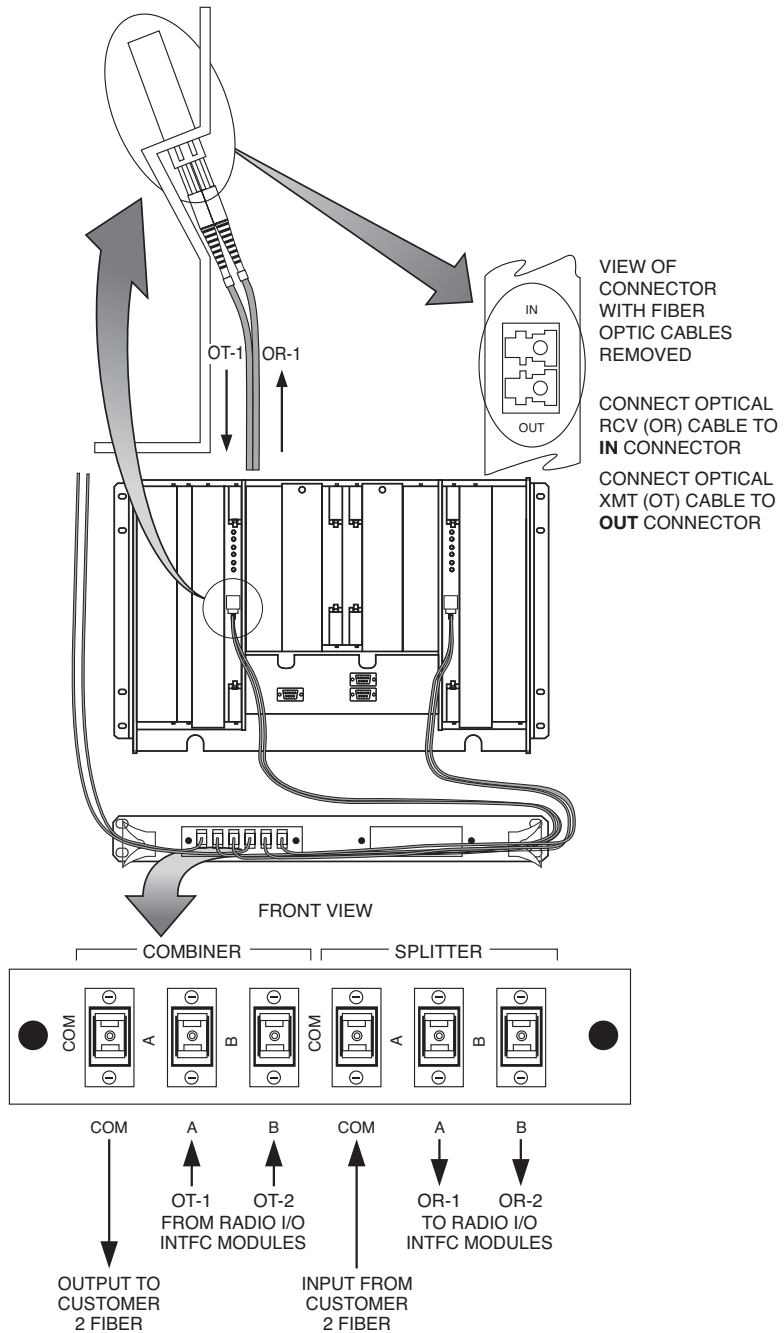

Figure 3-12 2 X 4 Fiber Management Panel

**3.13 OC3/STM-1 AUX INTERFACE BOARD WAYSIDE DS1 CONNECTIONS (J201 IN AND J202 OUT)**  
 Wayside DS1 is an option in the MDR-8000 OC3/STM-1 radios that prevents having to add a SONET add/drop MUX to access payload traffic. This option provides 1 DS1 for each STS-1 within the OC3/STM-1. Refer to Table 3-7 for ELMC option key requirements for remote monitoring/controlling wayside DS1.

**3.13.1 Wayside DS1 Terminal**

Recommended connectorized cable assembly – PN 695-4125-041 (26 AWG 5 pair shielded, jacketed cable with 9-pin D-type connector on one end). See Figure 3-13 for location. Refer to Figure 3-6 for pinout and color code.

**3.13.2 Wayside DS1 Repeater**

Recommended connectorized cable assembly – PN 695-4125-051 (26 AWG 5 pair shielded, jacketed cable with 9-pin D-type connector on each end). See Figure 3-13 for Wayside DS1 repeater interconnect. See Figure 3-8 for wayside DS1 repeater interconnect.

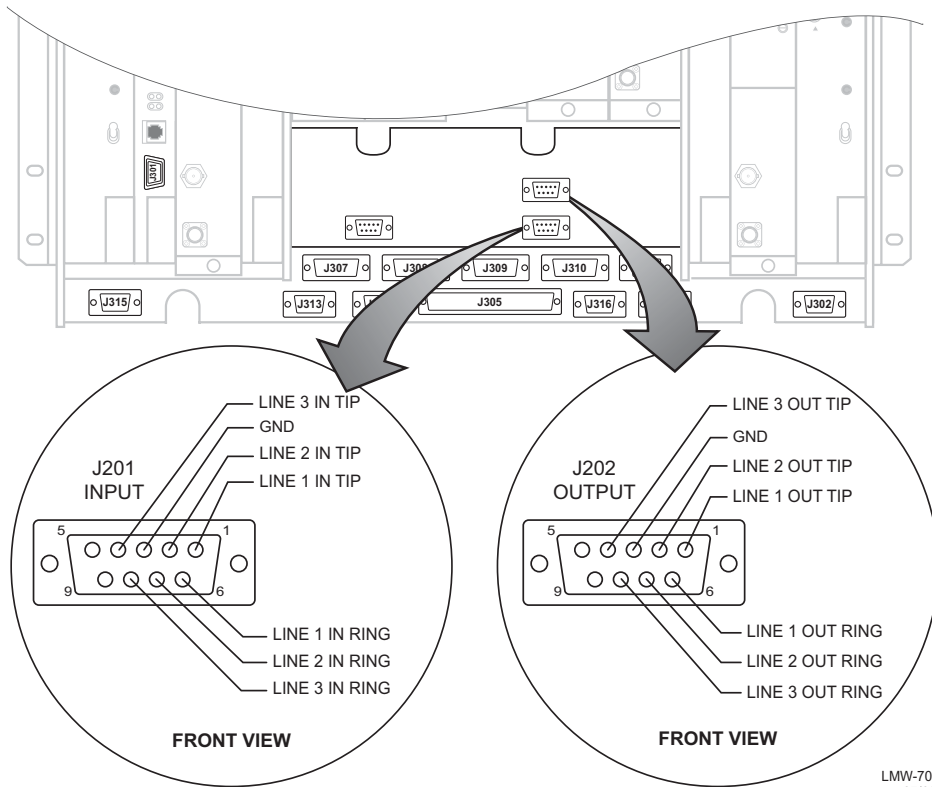

LMW-7068F  
07/23/02

**Figure 3-13 Wayside DS1 Connectors – OC3/STM-1 AUX Interface**

### 3.14 OC3/STM-1 REPEATER (J203 ON ONE SHELF TO J203 ON SECOND SHELF)

**Note**

The OC3/STM-1 radio repeater cable carries clocks, data, and overhead for two directions. It does not carry OC3/STM-1 or Wayside DS1 traffic. OC3/STM-1 fiber optic cables and Wayside DS1 cables must be run separately. If the repeater cable is not used, the embedded data in the overhead must be cabled individually. In this case, separate cables must be run for MCS-11, audio, RS-232, and ELMC.

Recommended connectorized cable assembly – PN 695-4125-007/013 (26 AWG 5 pair shielded, jacketed cable). See Figure 3-14 for shelf connector location and pinout. Refer to CD for mating cable wiring and color code.

**Note**

Use repeater cables for cabling repeater shelf 1 to repeater shelf 2 (eastbound/westbound data/clock)

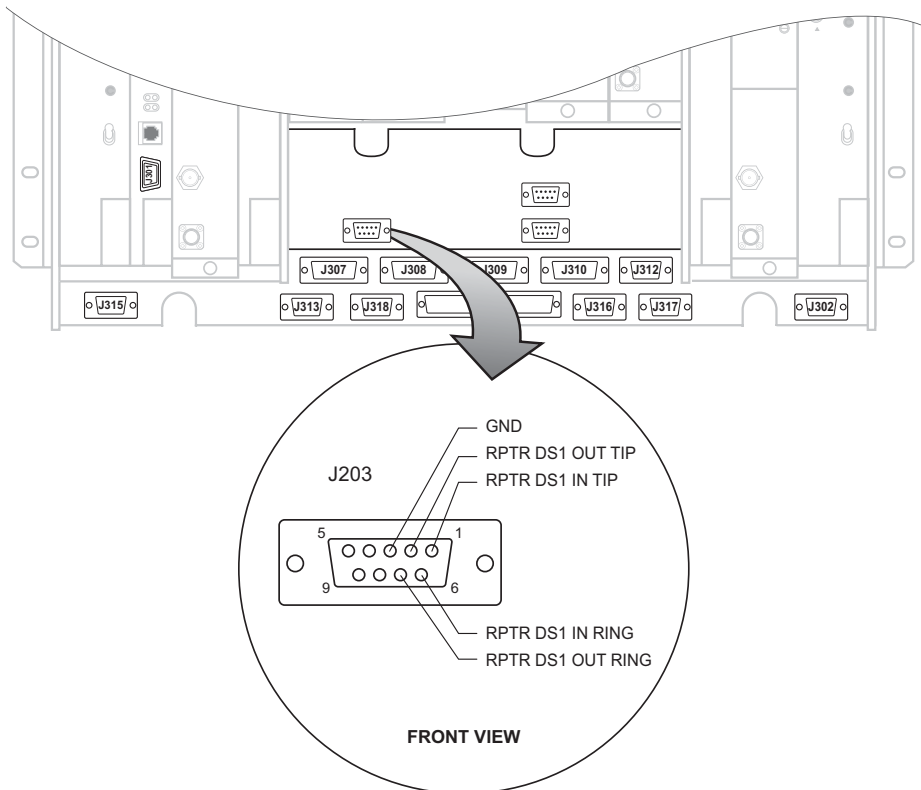

LMW-7067  
07/23/02

Figure 3-14 Repeater Connector – OC3/STM-1 AUX Interface

**Table 3-9 Repeater Mating Cable – OC3/STM-1 AUX Interface**

J203/J203 MDR-8000 OC3/STM-1			J203/J203	J203/J203 MDR-8000 OC3/STM-1		
FUNCTION	END 1	WIRE COLOR	PAIR	WIRE COLOR	END 2	FUNCTION
DS1 IN TIP	01	BLACK	1	BLACK	02	DS1 OUT TIP
DS1 IN RING	06	RED		RED	07	DS1 OUT RING
DS1 OUT TIP	02	BLACK	2	BLACK	01	DS1 IN TIP
DS1 OUT RING	07	WHITE		WHITE	06	DS1 IN RING
NOT USED		BLACK	3	BLACK		NOT USED
GND	03	GREEN		GREEN	03	GND
NOT USED	04	BLACK	4	BLACK	05	NOT USED
NOT USED	08	BLUE		BLUE	09	NOT USED
NOT USED	05	BLACK	5	BLACK	04	NOT USED
NOT USED	09	YELLOW		YELLOW	08	NOT USED

### 3.15 ETHERNET CABLE CONNECTIONS

Part numbers are assigned for unshielded, straight-through CAT5 UTP (PN 3AL48960AA-AL) and CAT5E UTP (PN 3AL15052AA-AL) cables. The CAT5 or CAT5E cables can be used for 10/100/1000BASE-T applications, however the CAT5E cable is the recommended cable for 1000BASE-T applications. The CAT5E cable has a tighter, higher quality twisting on the wire pairs and is less susceptible to crosstalk. Refer to Table 3-10 and Table 3-11 for pinout. See Figure 3-15 for pair wire colors. See Figure 3-16 and Figure 3-17 for interconnect information.

#### 3.15.1 Automatic MDI/MDI-X Configuration

The Ethernet PHY provides automatic Medium Dependent Interface (MDI/Medium Independent Interface-crossover (MDI-X)). Automatic MDI/MDI-X configuration eliminates the need for crossover cables.

### 3.15.2 Crossover Cable Option

Crossover type cables with pin 1 wired to pin 3 and pin 2 wired to pin 6 can be used, but are not necessary. Crossover is automatically performed by the Ethernet PHY, resulting in a straight-through interface to the link partner.

**Table 3-10 10/100BASE-T Ethernet Connector Pinout**

PIN	FUNCTION	PORT	
		MDI	MDI-X
1	TD+	Output	Input
2	TD+	Output	Input
3	RD+	Input	Output
4/5	GRD	N/A	N/A
6	RD-	Input	Output
7/8	GRD	N/A	N/A

**Table 3-11 1000BASE-T Ethernet Connector Pinout**

PIN	FUNCTION	DIRECTION
1	TRDA+	Input/Output
2	TRDA-	Input/Output
3	TRDB+	Input/Output
4	TRDB-	Input/Output
5	TRDC+	Input/Output
6	TRDC-	Input/Output
7	TRDD+	Input/Output
8	TRDD-	Input/Output

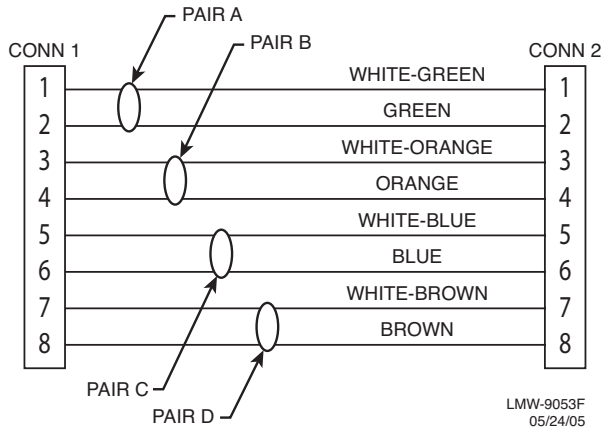

Figure 3-15 Straight-Through Mating Cable

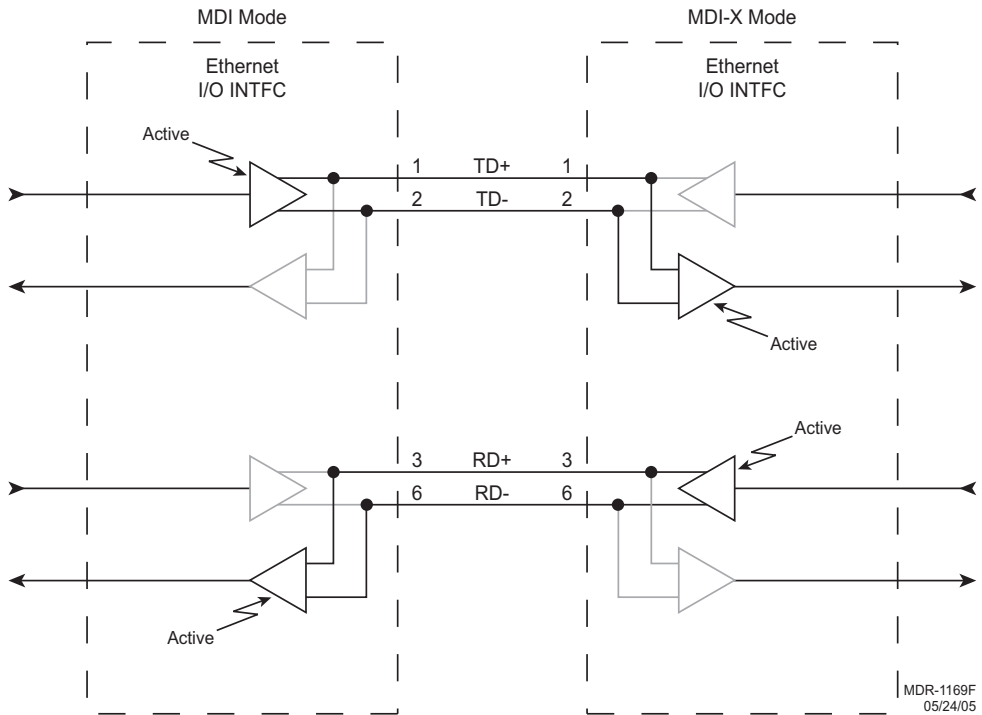
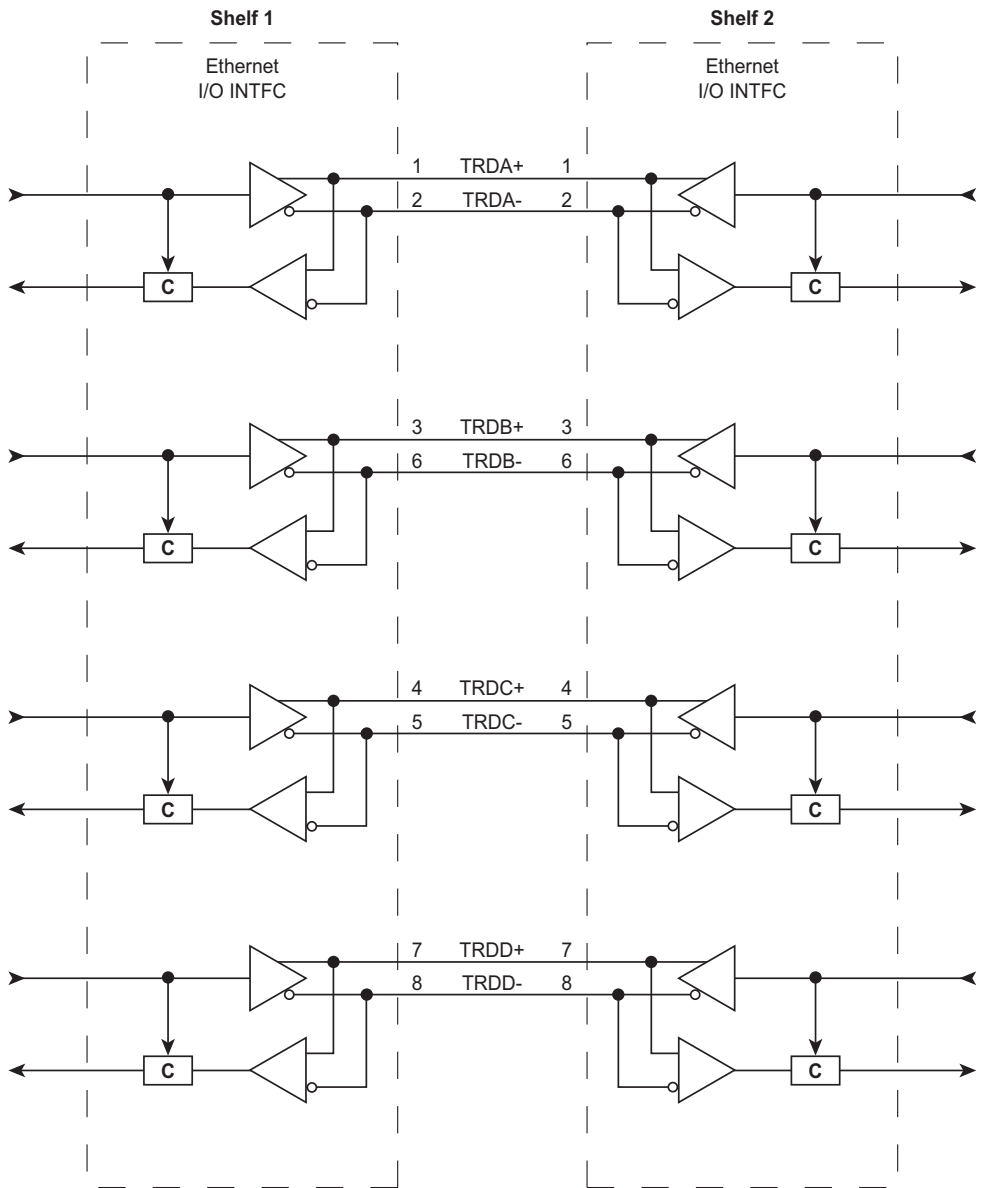

Figure 3-16 10/100BASE-T Interconnect



**C** = Cancel. Cancels XMT data in RCV output.

MDR-1170F  
05/24/05

Figure 3-17 1000BASE-T Interconnect

**Note**

*Transmit data (TRD) is both directions, simultaneously. Unwanted data is cancelled.*

**WARNING**

*Possibility of  
Damage  
to Equipment*

**Follow carefully the following do's and don'ts to prevent future loss of traffic.**

**DO** MAINTAIN A MAXIMUM BEND RADIUS OF 4 TIMES CABLE DIAMETER (4-PAIR CABLES).

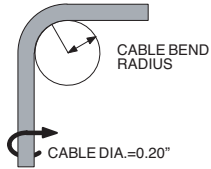

**DON'T** EXCEED A 90 DEGREE BEND.

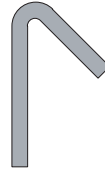

**DO** APPLY CABLE TIES LOOSELY AND AT RANDOM INTERVALS.



**DON'T** OVERTIGHTEN CABLE TIES.

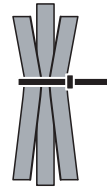

**DO** TRY TO MINIMIZE THE AMOUNT OF JACKET TWISTING.



**DON'T** OVERTWIST CABLE; IT CAN LEAD TO TORN JACKETS.

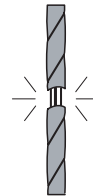

**DO** AVOID STRETCHING CABLE.

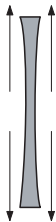

**DON'T** EXCEED 25 LB OF PULLING TENSION.



MW215-0028-1  
071897



### 3.15.3 Terminal Connections

See Figure 3-18. Radio terminal connections consist of Ethernet connections (refer to Para 3.6), DS1 connections, and service channel connections. The radio provisioned as a terminal can transport up to 32 DS1 lines in one direction.

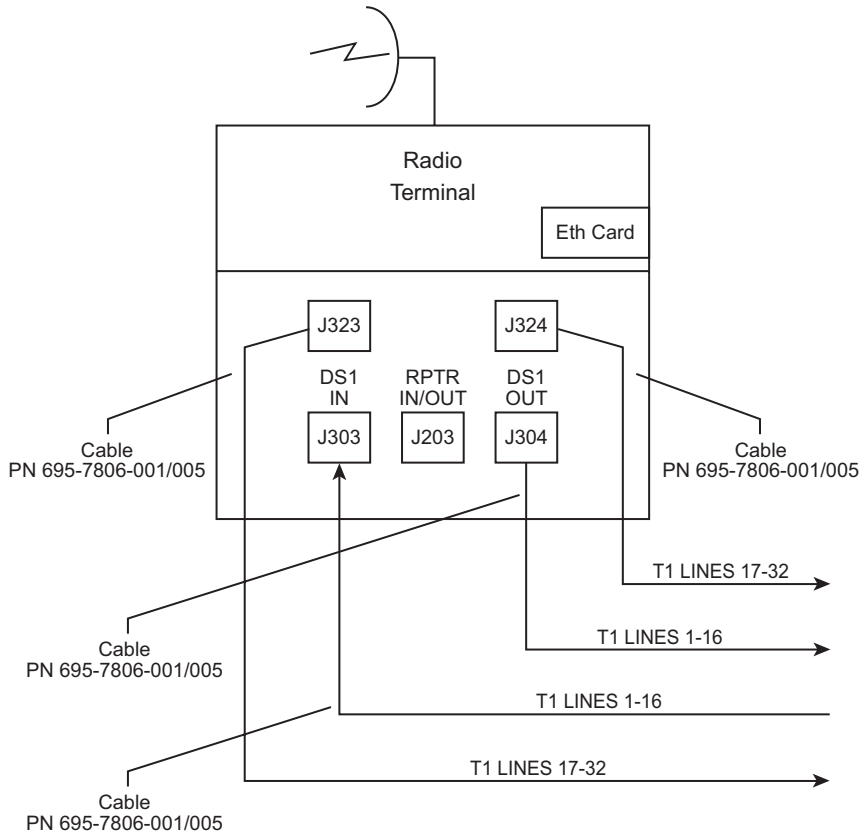

MDR-1299-SM  
07/09/07

Figure 3-18 Terminal Interconnect Diagram

### 3.15.3.1 Terminal DS1 Lines 1-32 Connections (J303/J323 In and J304/J324 Out)

Recommended connectorized cable assembly – PN 695-7806-001 through 005 (22 AWG 16-pair shielded, jacketed cable with 37-pin D-type connector on one end). See Figure 3-19 for location and pinout. Refer to Table 3-12 and Table 3-13 for mating cable pinout.

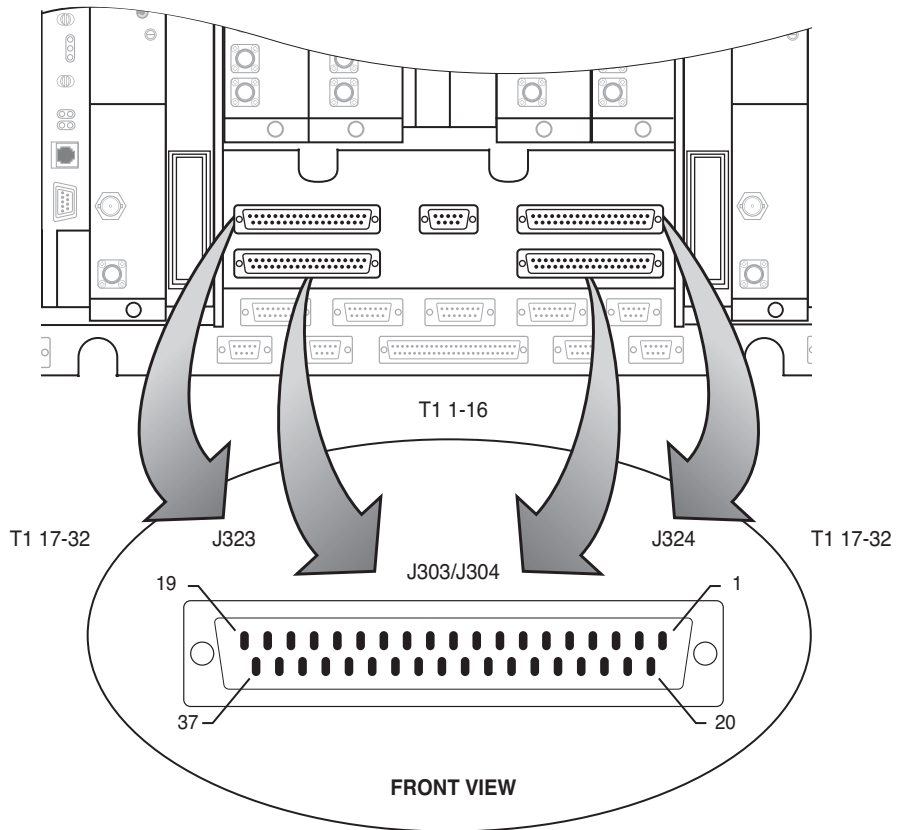

LMW-9037F-SM  
07/03/07

Figure 3-19 DS1 Lines 1-32 Connectors – Location and Pinout

**Table 3-12 DS1 IN J303 and DS1 OUT J304 Pinout Assignments**

CONNECTOR PIN NUMBER	WIRE COLOR	SIGNAL NAME	CABLE PAIR NUMBER
1	WHITE-BLUE	CHAN 1 TIP	1
20	BLUE-WHITE	CHAN 1 RING	
2	WHITE-ORANGE	CHAN 2 TIP	2
21	ORANGE-WHITE	CHAN 2 RING	
3	WHITE-GREEN	CHAN 3 TIP	3
22	GREEN-WHITE	CHAN 3 RING	
4	WHITE-BROWN	CHAN 4 TIP	4
23	BROWN-WHITE	CHAN 4 RING	
5	WHITE-SLATE	CHAN 5 TIP	5
24	SLATE-WHITE	CHAN 5 RING	
6	RED-BLUE	CHAN 6 TIP	6
25	BLUE-RED	CHAN 6 RING	
7	RED-ORANGE	CHAN 7 TIP	7
26	ORANGE-RED	CHAN 7 RING	
8	RED-GREEN	CHAN 8 TIP	8
27	GREEN-RED	CHAN 8 RING	
9	RED-BROWN	CHAN 9 TIP	9
28	BROWN-RED	CHAN 9 RING	
10	RED-SLATE	CHAN 10 TIP	10
29	SLATE-RED	CHAN 10 RING	
11	BLACK-BLUE	CHAN 11 TIP	11
30	BLUE-BLACK	CHAN 11 RING	
12	BLACK-ORANGE	CHAN 12 TIP	12
31	ORANGE-BLACK	CHAN 12 RING	
13	BLACK-GREEN	CHAN 13 TIP	13
32	GREEN-BLACK	CHAN 13 RING	
14	BLACK-BROWN	CHAN 14 TIP	14
33	BROWN-BLACK	CHAN 14 RING	
15	BLACK-SLATE	CHAN 15 TIP	15
34	SLATE-BLACK	CHAN 15 RING	
16	YELLOW-BLUE	CHAN 16 TIP	16
35	BLUE-YELLOW	CHAN 16 RING	

**Table 3-13 DS1 IN J323 and DS1 OUT J324 Pinout Assignments**

CONNECTOR PIN NUMBER	WIRE COLOR	SIGNAL NAME	CABLE PAIR NUMBER
1	WHITE-BLUE	CHAN 17 TIP	1
20	BLUE-WHITE	CHAN 17 RING	
2	WHITE-ORANGE	CHAN 18 TIP	2
21	ORANGE-WHITE	CHAN 18 RING	
3	WHITE-GREEN	CHAN 19 TIP	3
22	GREEN-WHITE	CHAN 19 RING	
4	WHITE-BROWN	CHAN 20 TIP	4
23	BROWN-WHITE	CHAN 20 RING	
5	WHITE-SLATE	CHAN 21 TIP	5
24	SLATE-WHITE	CHAN 21 RING	
6	RED-BLUE	CHAN 22 TIP	6
25	BLUE-RED	CHAN 22 RING	
7	RED-ORANGE	CHAN 23 TIP	7
26	ORANGE-RED	CHAN 23 RING	
8	RED-GREEN	CHAN 24 TIP	8
27	GREEN-RED	CHAN 24 RING	
9	RED-BROWN	CHAN 25 TIP	9
28	BROWN-RED	CHAN 25 RING	
10	RED-SLATE	CHAN 26 TIP	10
29	SLATE-RED	CHAN 26 RING	
11	BLACK-BLUE	CHAN 27 TIP	11
30	BLUE-BLACK	CHAN 27 RING	
12	BLACK-ORANGE	CHAN 28 TIP	12
31	ORANGE-BLACK	CHAN 28 RING	
13	BLACK-GREEN	CHAN 29 TIP	13
32	GREEN-BLACK	CHAN 29 RING	
14	BLACK-BROWN	CHAN 30 TIP	14
33	BROWN-BLACK	CHAN 30 RING	
15	BLACK-SLATE	CHAN 31 TIP	15
34	SLATE-BLACK	CHAN 31 RING	
16	YELLOW-BLUE	CHAN 32 TIP	16
35	BLUE-YELLOW	CHAN 32 RING	

### 3.15.4 Repeater Connections

See Figure 3-20. Radio repeater connections consist of Ethernet connections (refer to Para. 3.15), DS1 connections, and service channel connections. When the radio is provisioned as a repeater, service channel overhead is transported between shelves at the DS1 data rate using the RPTR IN/OUT connector J203 on the ETH/T1 line interface board.

#### 3.15.4.1 Repeater DS1 Lines 1-32 Connections (J201/J323 In and J202/J324 Out)

Recommended connectorized cable assembly – PN 695-7806-XXX (22 AWG 16-pair shielded, jacketed cable with 37-pin D-type connector on each end). See Figure 3-19 for location and pinout. Refer to Table 3-12 and Table 3-13 for mating cable and pinout.

#### 3.15.4.2 Repeater Service Channel Connections (J203 on one shelf to J203 on second shelf)

Recommended connectorized cable assembly – PN 695-4125-007/013 (26 AWG 5-pair shielded, jacketed cable with 9-pin D-type connector on each end). see Figure 3-20 for location and pinout. Refer to Table 3-14 for mating cable pinout.

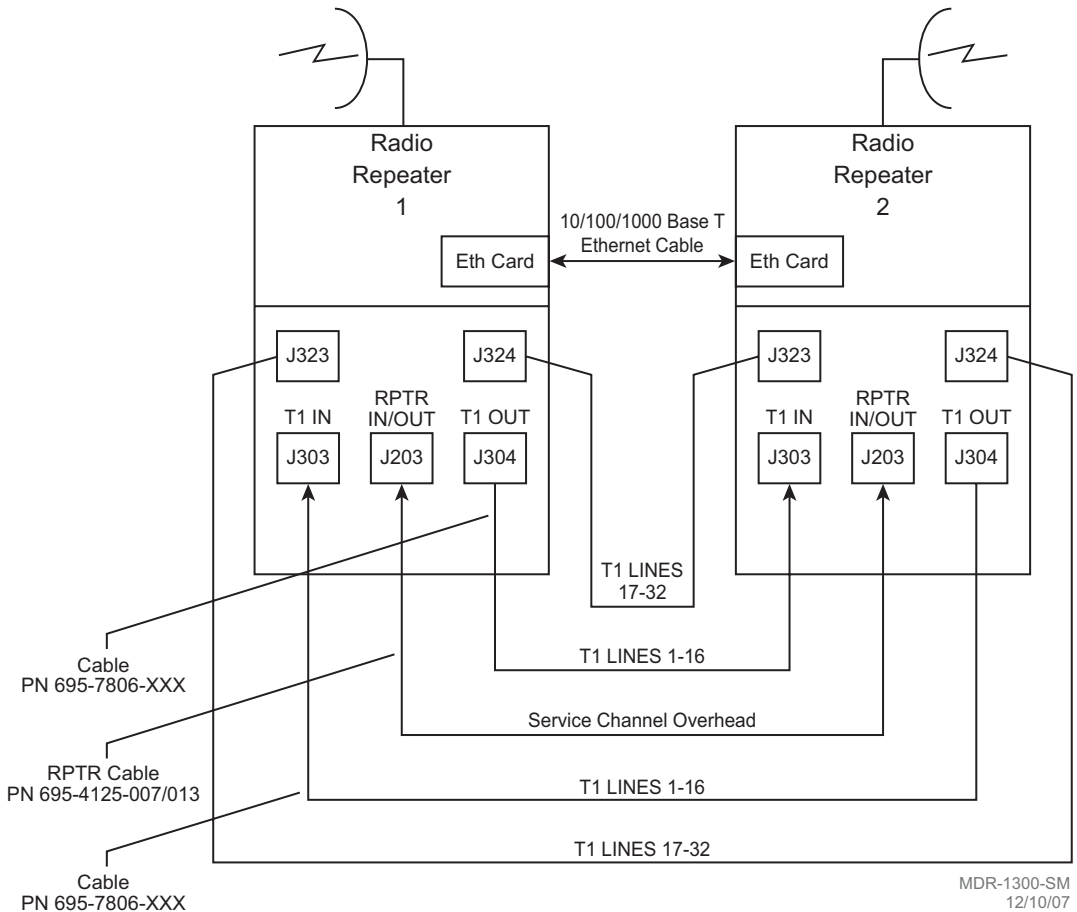

Figure 3-20 Repeater Interconnect Diagram

**Table 3-14 Repeater Mating Cable – ETH/T1 Line**

J203/J203 MDR-8000			J203/ J203	J203/J203 MDR-8000		
FUNCTION	END 1	WIRE COLOR	PAIR	WIRE COLOR	END 2	FUNCTION
DS1 IN TIP	01	BLACK	1	BLACK	02	DS1 OUT TIP
DS1 IN RING	06	RED		RED	07	DS1 OUT RING
DS1 OUT TIP	02	BLACK	2	BLACK	01	DS1 IN TIP
DS1 OUT RING	07	WHITE		WHITE	06	DS1 IN RING
NOT USED		BLACK	3	BLACK		NOT USED
GND	03	GREEN		GREEN	03	GND
NOT USED	04	BLACK	4	BLACK	05	NOT USED
NOT USED	08	BLUE		BLUE	09	NOT USED
NOT USED	05	BLACK	5	BLACK	04	NOT USED
NOT USED	09	YELLOW		YELLOW	08	NOT USED

### 3.16 USI/CONTROLLER CABLE CONNECTION TO LAPTOP (J301)

Recommended connectorized cable assembly – PN 695-7848-001 through 004 (24 AWG 6 pair shielded, jacketed cable with DEMM-9P connector on each end). See Figure 3-21 for Figure 3-22 for controller connector location and pinout. Refer to Table 3-17 for mating cable pinout and color code.

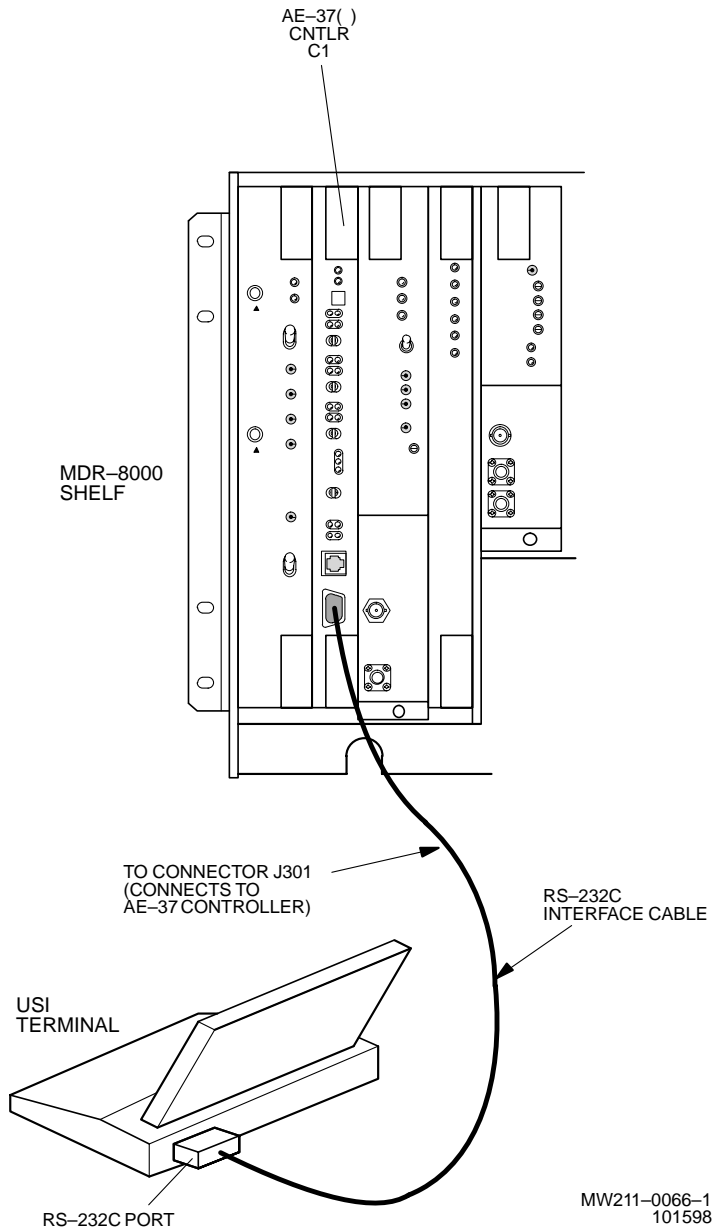

MW211-0066-1  
101598

Figure 3-21 USI Computer to Controller Interconnection

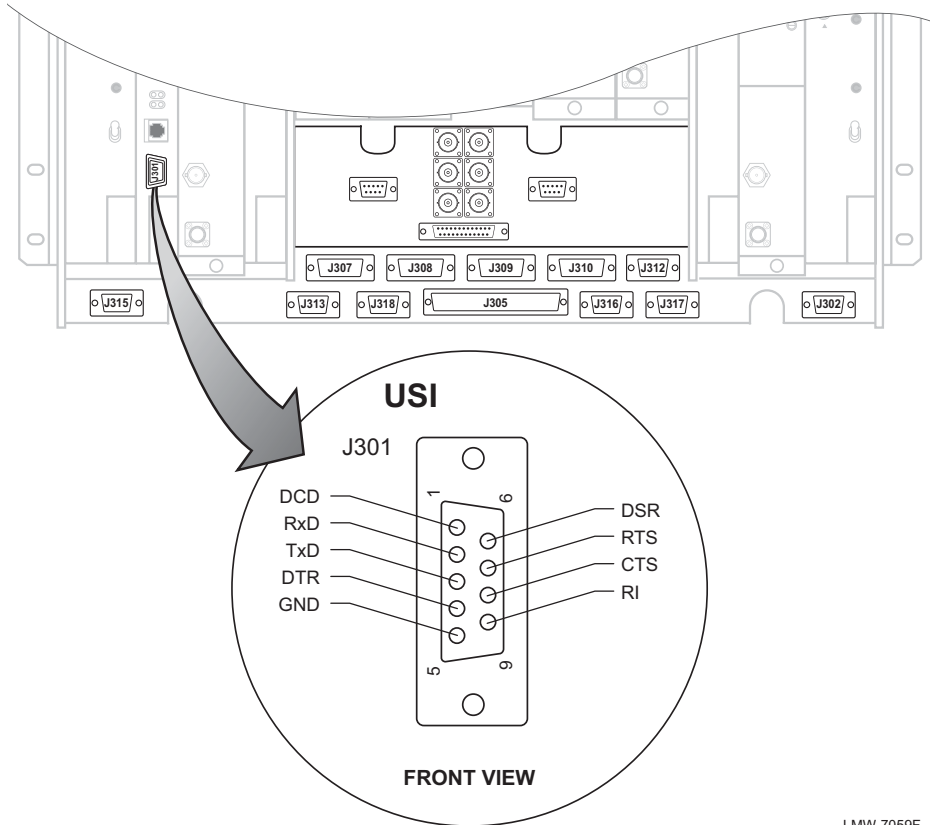

LMW-7059F  
02/04/03

Figure 3-22 Controller USI Connector Location and Pinout



Table 3-15 Controller Mating Cable

J301 MDR-8000 CONTROLLER			J301/LAPTOP	LAPTOP		
FUNCTION	END 1	WIRE COLOR	PAIR	WIRE COLOR	END 2	FUNCTION
DCD	01	BLACK	1	BLACK	01	DCD
DSR	06	RED	1	RED	06	DSR
RXD	02	BLACK	2	BLACK	02	RXD
RTS	07	WHITE	2	WHITE	07	RTS
TXD	03	BLACK	3	BLACK	03	TXD
CTS	08	GREEN	3	GREEN	08	CTS
DTR	04	BLACK	4	BLACK	04	DTR
RI	09	BLUE	4	BLUE	09	RI
GND	05	BLACK	5	BLACK	05	GND
NOT USED	N/A	YELLOW	5	YELLOW	N/A	NOT USED
NOT USED	N/A	BLACK	6	BLACK	N/A	NOT USED
NOT USED	N/A	BROWN	6	BROWN	N/A	NOT USED

### 3.17 SERVICE CHANNEL CONNECTIONS

A service channel is defined as a non-revenue bearing channel provided as part of a transmission system for operation, maintenance, monitoring, and control of the system. The MDR-8000 provides a 256 kb/s auxiliary channel for servicing the radio. This is an overhead channel and is independent of the traffic channels. The 256 kb/s service channel contains four 64 kb/s service channels. Three of the four 64 kb/s channels (Service Channel 1, 2, and 3) can be provisioned on the USI for a specific use. Service channel 4 is dedicated to radio commands and ELMC. Service channel is not provisionable. The four channels are multiplexed and shifted in and out of registers on the controller.

See Figure 3-23. There are eight connectors on the backplane to interface with three of the service channels. The connectors on the backplane interface three functions: audio, RS-232, and MCS-11. Each service channel is provisioned for a specific function. As shown by the vertical line connecting to the three functions on one side and the three service channels (SC1, SC2, and SC3) on the opposite side, audio and MCS can be put on any open service channel. RS-232 data can be put on service channel 1 or 2 but cannot be put on service channel 3. This is shown by the dashed lines to the specific service channel.

#### 3.17.1 2-Wire Handset Connection

The 2-wire port at the TEL connector on AE-37Y Controller accepts either the optional handset, listed under equipment supplied in the General section, or a standard telephone. The 2-wire port is not provisionable and should not be confused with the 4-wire provisionable parts (Audio 1 and Audio 2). To use the handset, the radio must be provisioned for Audio 1.

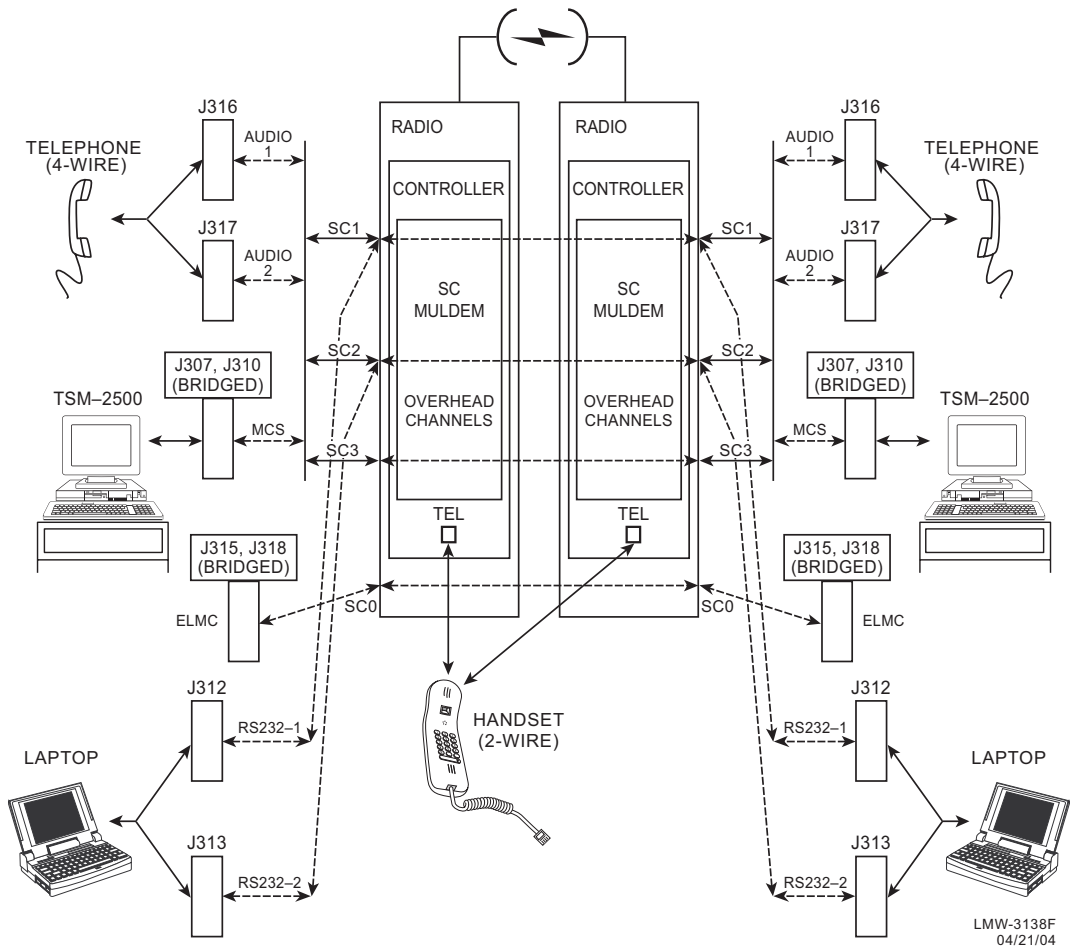

Figure 3-23 Service Channel Connections/Applications

### 3.17.2 Service Channels Provisioning Options

**Note**

*Service channels at both ends of a hop (and end-to-end in a link) must be provisioned the same.*

Service channel provisioning is interactive. When an option is selected for any service channel, that option is excluded from selections on the other applicable service channels. Provisioning options for Service Channels 1, 2, and 3 are listed:

- Service Channel 1 (64 kb/s channel) – can be used to carry 4-wire audio, RS-232 data, or MCS-11 fault alarm information.
  - AUDIO 1 and 2 – Two audio provisioning options (AUDIO 1 and AUDIO 2) are provided for Service Channel 1. Each audio channel is a 4-wire audio channel that provides off-hook detection, level control, and E and M-lead signaling. AUDIO 1 also has DTMF decoding that allows a specific station to be dialed. External connection to AUDIO 1 is J316. External connection to AUDIO 2 is J317.
  - RS-232-1 – RS-232 Channel 1 is an RS-232 formatted data channel that can provide interface to an external computer/modem. External connection to RS-232-1 is J312.
  - MCS-11 – The MCS-11 channel is an RS-422 formatted data that provides an interface to an external MCS-11 Monitor and Control System or TSM system, used to control multiple MCS-11 systems. External connections to the MCS-11 include J307, J308, J309 and J310.
- Service channel 2 (64 kb/s channel) – can be used to carry 4-wire audio, RS-232 data, or MCS-11 fault alarm information.
  - AUDIO-1 and -2 – Same as Service Channel 1
  - RS-232-2 – RS-232 Channel 2 is an RS-232 formatted data channel that can provide interface to an external computer/modem. External connection to RS-232-2 is J313.
  - MCS-11 – Same as Service Channel 1
- Service Channel 3 (64 kb/s channel) – can be used to carry 4-wire audio, or MCS-11 fault alarm information
  - AUDIO 1 and 2 – Same as Service Channel 1
  - MCS-11 – Same as Service Channel 1.

#### 3.17.3 Audio 1, Audio 2 (J316, J317) Connections

The Audio 1 and 2 4-wire functions are provisionable. Refer to the Initial Turnup section for details. These audio functions should not be confused with the non-provisionable 2-wire handset.

### 3.17.3.1 Audio 1

Audio 1 (J316) is a 4-wire function port on the backplane that provides off-hook detection, level control, E and M-lead signaling, and DTMF and 2-wire handset capabilities.

### 3.17.3.2 Audio 2

Audio 2 (J317) is a 4-wire function port on the backplane that provides off-hook detection, level control, and E and M-lead signaling. Audio 2 has no DTMF decoding capabilities.

Recommended connectorized cable assembly – PN 695-4125-026 through 030 (26 AWG 5 pair shielded, jacketed cable with 9-pin D-type connector on each end). See Figure 3-24 for shelf connector locations and pinout. Refer to Table 3-16 for mating cable wiring and color code.

or

Recommended cable – PN 424-0305-030 (26 AWG 5 pair shielded, jacketed cable) for wire-wrapping to wirewrap adapter PN 3DH04178AB. See Figure 3-25 for pinout.

Table 3-16 Audio Mating Cable Wiring and Color Codes

FUNCTION	END 1	WIRE COLOR	PAIR	WIRE COLOR	END 2	FUNCTION
AUDIO TIP IN	01	BLACK	1	BLACK	03	AUDIO TIP OUT
AUDIO RING IN	06	RED	1	RED	08	AUDIO RING OUT
AUDIO M LEAD	02	BLACK	2	BLACK	07	AUDIO E LEAD
AUDIO E LEAD	07	WHITE	2	WHITE	02	AUDIO M LEAD
AUDIO TIP OUT	03	BLACK	3	BLACK	01	AUDIO TIP IN
AUDIO RING OUT	08	GREEN	3	GREEN	06	AUDIO RING IN
CALL DETECT	04	BLACK	4	BLACK	04	NOT USED
CALL COMMON	09	BLUE	4	BLUE	09	NOT USED
GND	05	BLACK	5	BLACK	05	GND
NOT USED	10	YELLOW	5	YELLOW	10	NOT USED

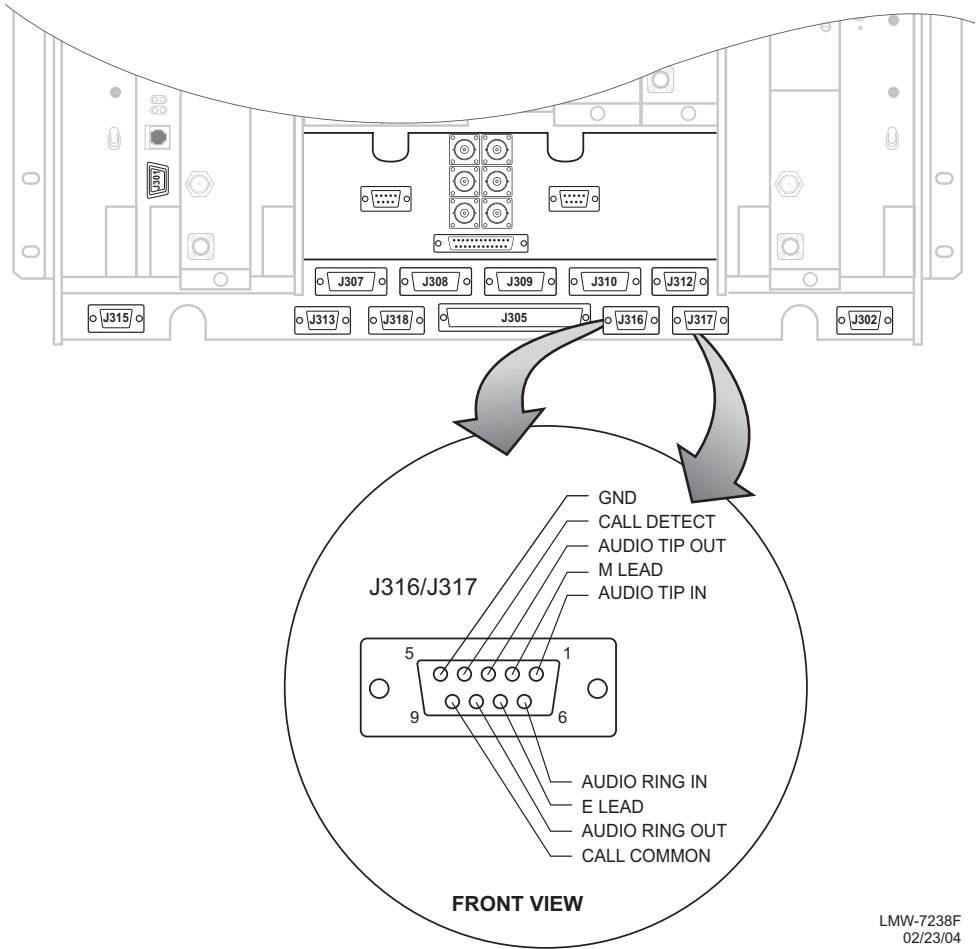

LMW-7238F  
02/23/04

Figure 3-24 Audio Connectors Location and Pinout

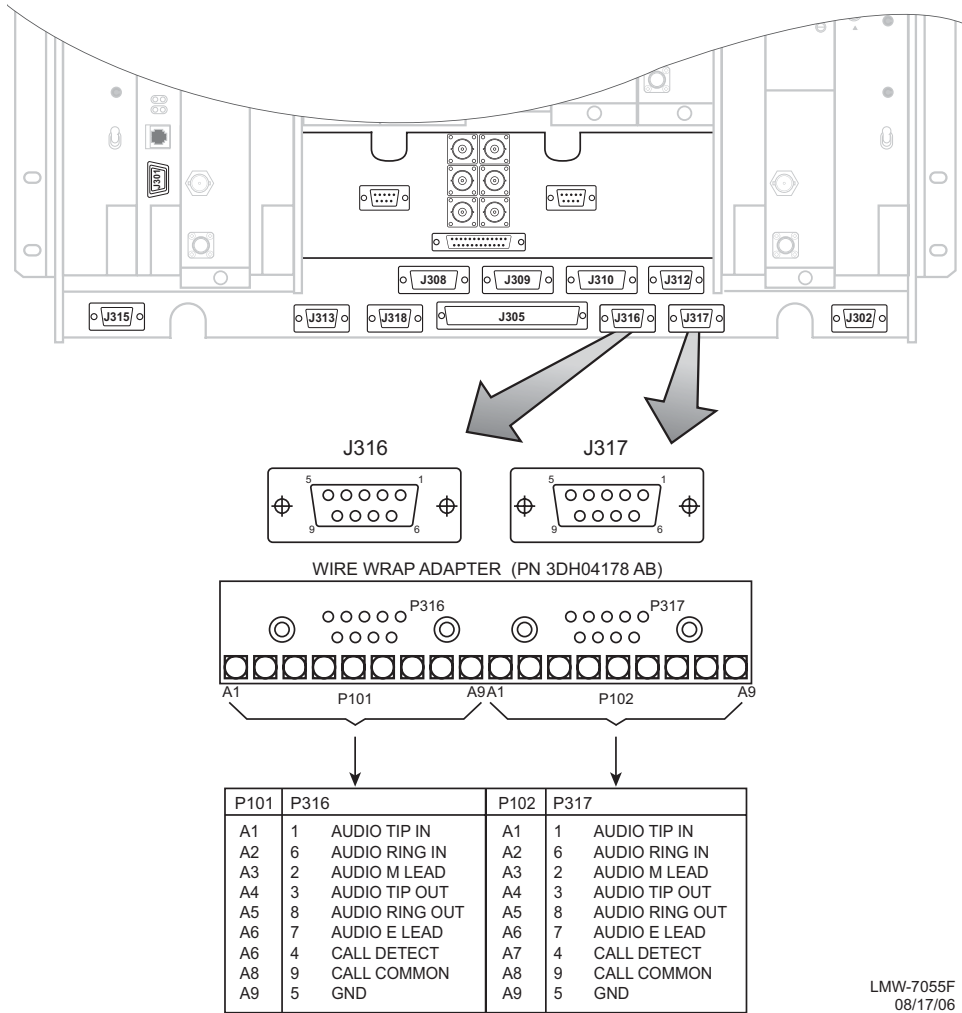

LMW-7055F  
08/17/06

Figure 3-25 Audio Wirewrap Adapter Pinout

### 3.17.4 RS-232-1, RS-232-2 (J312, J313)

Recommended connectorized cable assembly – PN 695-4125-021 through 025 (26 AWG 5 pair shielded, jacketed cable with 9-pin D-type connector on each end). See Figure 3-26 for shelf connector locations and pinout. Refer to Table 3-17 for mating cable wiring and color code.

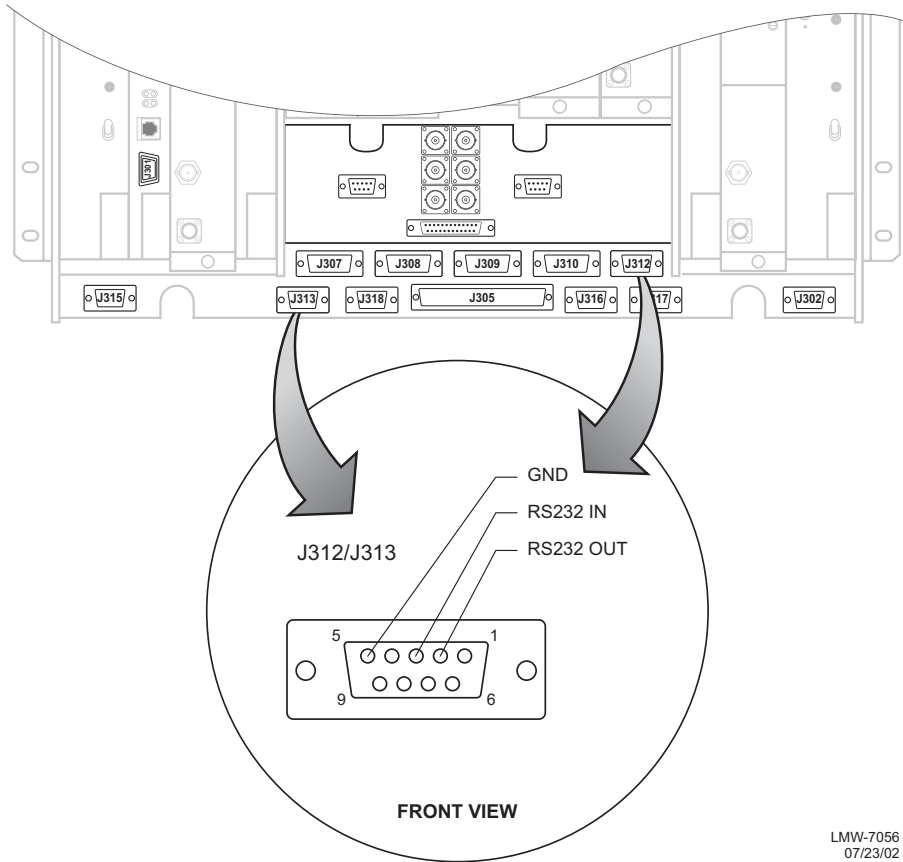

LMW-7056  
07/23/02

Figure 3-26 RS-232 Connectors Location and Pinout

Table 3-17 RS-232 Mating Cable Wiring and Color Codes

J312/J313 MDR-8000			J312/ J313	J312/J313 MDR-8000		
FUNCTION	END 1	WIRE COLOR	PAIR	WIRE COLOR	END 2	FUNCTION
NOT USED	01	BLACK	1	BLACK	01	NOT USED
NOT USED	06	RED	1	RED	06	NOT USED
RS-232 OUT/RS-232-1 OUT*	02	BLACK	2	BLACK	03	RS-232 IN/RS-232-1 IN*
NOT USED	07	WHITE	2	WHITE	08	NOT USED
RS-232 IN/RS-232-1 IN*	03	BLACK	3	BLACK	02	RS-232 OUT/RS-232-1 OUT*
NOT USED	08	GREEN	3	GREEN	07	NOT USED
NOT USED/ RS-232-2 OUT*	04	BLACK	4	BLACK	04	NOT USED/RS-232-2 OUT*
NOT USED/RS-232-2 IN*	09	BLUE	4	BLUE	09	NOT USED/RS-232-2 IN*
GND	05	BLACK	5	BLACK	05	GND
NOT USED	10	YELLOW	5	YELLOW	10	NOT USED

\*J312 on Compact Radio

### 3.18 MCS-11 CONNECTIONS

When MCS is selected to be placed on one of the three service channels and then RSS is enabled and properly addressed, applicable ports on the controller module are enabled. This allows the user to interface external MCS-11 Monitor and Control System equipment at any or all four connectors on the backplane (J307, J308, J309, and J310). Two connectors (J308 and J309) are synchronous, parallel, data ports and provide CLK outputs. Connectors J307 and J310 are asynchronous ports.

For proper operation, MCS-11 must be provisioned using the following guidelines:

- a. **MCS-11** must be selected as one of the service channels.
- b. MCS must be assigned a valid address
- c. The **MCS RSS** must be set to **ON** for each radio with a unique RSS address. Refer to Appendix B on the attached CD for address details. At a site, typically only one RSS is turned on. Station scanners at all other radios at that site are normally jumpered to the RSS enabled radio to allow access to their detail scanners. If station scanners are properly wired, detail scanners always respond, regardless of whether RSS is provisioned **ON** or **OFF**.



### 3.18.1 MCS-11 Master (J307)

#### Note

If the radio is provisioned **Repeater**, port 2 on the controller, that connects to J307, is disabled. At a repeater, you can use J310 in lieu of J307 for connecting the TSM polling engine to the radio.

MCS-11 connector J307 is used to connect to a TSM (-2500, -3500, or -8000) polling engine at a master terminal.

Recommended connectorized cable assembly – PN 695-4126-007/009/012 (26 AWG 8 pair shielded, jacketed cable). See Figure 3-27 for shelf connector location and pinout. Refer to Table 3-18 for mating cable pinout and color code. See Figure 3-28 for typical connection scheme.

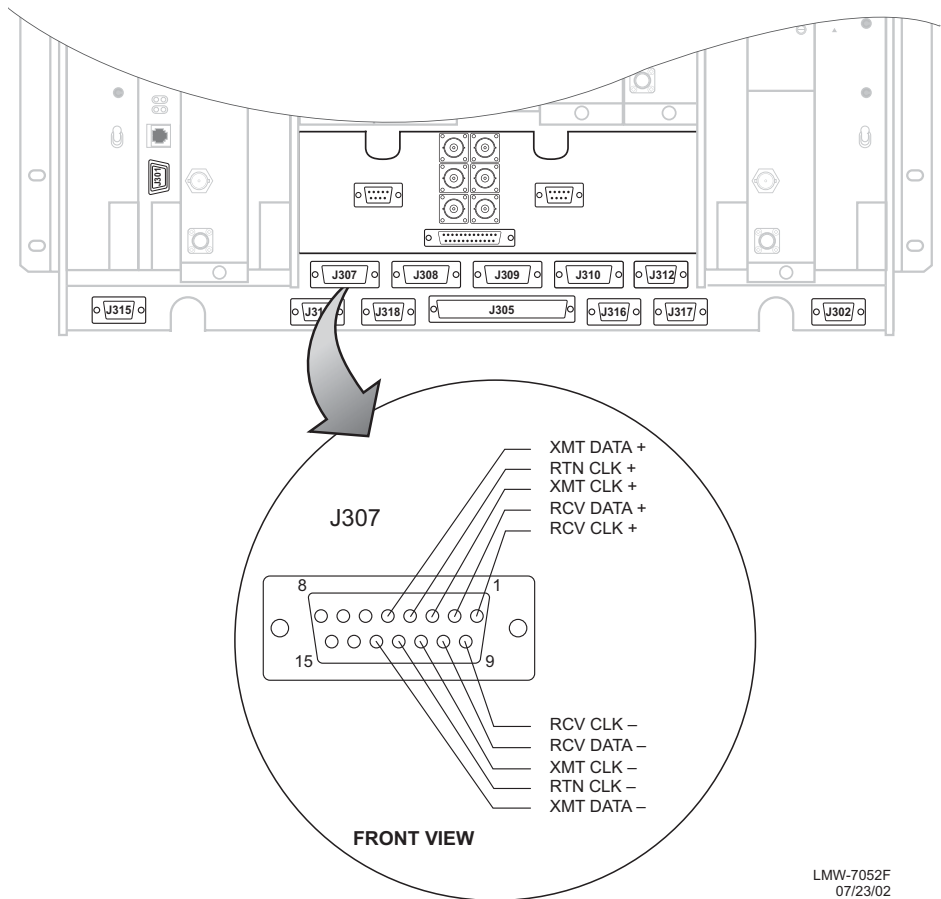

LMW-7052F  
07/23/02

Figure 3-27 MCS-11 Master Connector (J307) Location and Pinout

**Table 3-18 MCS-11 Master Connector J307 Mating Cable Wiring and Color Codes**

J307 MDR-8000				POLLING ENGINE		
FUNCTION	END 1	WIRE COLOR	PAIR	WIRE COLOR	END 2	FUNCTION
RCV CLK +	01	BLACK	1	BLACK	01	RCV CLK +
RCV CLK-	09	RED	1	RED	09	RCV CLK-
RCV DATA +	02	BLACK	2	BLACK	02	RCV DATA +
RCV DATA -	10	WHITE	2	WHITE	10	RCV DATA -
XMT CLK +	03	BLACK	3	BLACK	03	XMT CLK +
XMT CLK -	11	GREEN	3	GREEN	11	XMT CLK -
RETURN CLK +	04	BLACK	4	BLACK	04	RETURN CLK +
RETURN CLK -	12	BLUE	4	BLUE	12	RETURN CLK -
XMT DATA +	05	BLACK	5	BLACK	05	XMT DATA +
XMT DATA -	13	YELLOW	5	YELLOW	13	XMT DATA -
NOT USED	06	BLACK	6	BLACK	06	OFF HOOK +
NOT USED	14	BROWN	6	BROWN	14	OFF HOOK -
NOT USED	07	BLACK	7	BLACK	07	RCV DATA
NOT USED	15	ORANGE	7	ORANGE	15	SIG GND
NOT USED	08	RED	8	RED	08	DTR
NOT USED	16	WHITE	8	WHITE	16	NOT USED

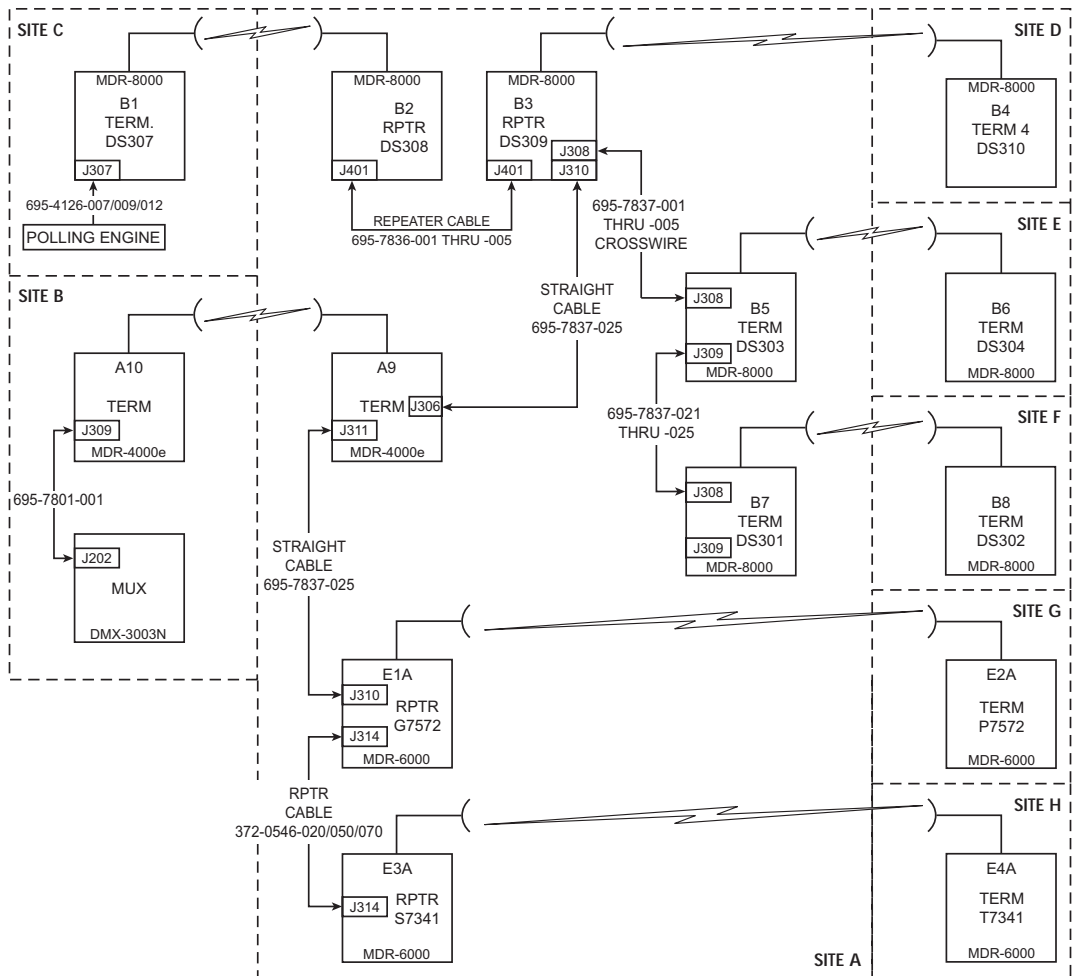

LEGEND:

XXXX	← MCS-11 ADDRESS
YYYY	← CONFIGURATION
ZZZZ	← ELMC ADDRESS

DS3ZZ = RADIO CAPACITY (DS3)  
AND SHELF NUMBER (DS301 - SHELF 1)

**MDR-8000 J308/J309  
PROVISIONING NOTES**

1. PROVISION RPTR DS309 (FIRST RADIO IN CHAIN) J308 OUTPUT CLOCK.
2. PROVISION ALL OTHER RADIOS IN DAISY CHAIN (TERM DS303 AND TERM DS301) J308 INPUT CLOCK.

MDR-1023F  
06/08/04

Figure 3-28 Typical MCS-11 System

### 3.18.2 MCS-11 Repeater-to-Spur Daisy Chain Connection (J308/J309)

#### Note

*MCS-11 must be provisioned **MCS-11 J310 Master/Junction** to enable XMT, RCV, and OUTPUT clocks. If an external modem is being used, provision MCS-11 for **MCS-11 J310 Modem**. This selection disables XMT, RCV, OUTPUT clocks and all MCS-11 clocks must now be provided by the external modem.*

#### Note

*Multiple radios at a site can be provisioned and connected to operate using a common XMT and RCV clock. In this scenario, one radio is provisioned to supply the clocks. All other radios are provisioned to sync off the supplied clocks. Provision the radio supplying the clocks **J308 Output Clock**. Provision all other radios at the site **J308 Input Clock**.*

MCS-11 connectors J308 and J309 are typically used to sync radios at a site with multiple radios configured as junctions, spurs, and/or daisy-chained spurs. The multiple radios are connected to common XMT and RCV clocks. In this scenario, one radio is provisioned to supply the clocks. This radio is designated “master” or DCE. All other radios at the site are designed as “slave” or DTE and receive their sync from the master.

See Figure 3-29 for a typical connection scheme for three radios. Shelf 1 is the master (DCE) radio. Shelf 1 is provisioned J308 Output Clock. Shelves 2 and 3 (slaves) sync to Shelf 1 and are provisioned J308 Input clock. Either Repeater Shelf 1 or Repeater Shelf 2 may feed the spur shelf. The first connection out of the repeater must be crosswired from J308 to J308. Then, every shelf from the spur must be wired 1:1, J309 to J308, in a daisy-chain fashion.

#### 3.18.2.1 Clock Master and Slave Modes

Clock direction is controlled by the MASTER/SLAVE control from the microprocessor. Switching is controlled by the CLK E DET control and the Master/Slave control from the microprocessor. The master and slave modes are provisioned functions. The master mode is set by provisioning the radio J308 Output Clock. The slave mode is set by provisioning the radio J308 Input Clock.

### 3.18.2.2 Master Mode (CLKS OUT)

See Figure 3-30 for a simplified block diagram of the master mode. The master mode sends RCV and XMT clocks out to other equipment. Typically one radio at a repeater/junction is provisioned J308 Output clock and this master radio provides the clocks on which other radios at the site can sync. The east and west service channel modems on the controller provide the XMT and RCV clocks. The east service channel modem provides the 64k CLK E (64 kHz clock east) that is switched through the EPLD, amplified by the clock driver and output through the bi-directional XCVR to connector J308. The west service channel modem provides the 64k CLK W (64 kHz clock west) that is switched through the EPLD, amplified by the clock driver and output through the bi-directional XCVR to connector J308.

### 3.18.2.3 Slave Mode (CLKS IN)

See Figure 3-31 for a simplified block diagram of the slave mode. The slave mode receives RCV and XMT clocks from other equipment. Typically all but one radio at a repeater/junction are provisioned J308 Input clock. The master radio provides the clocks on which the slave radios at the site can sync. The RCV clock on J308 is passed through the bi-directional XCVR, is switch through the EPLD, and output to the microprocessor as CLK 7. The XMT clock on J308 is passed through the bi-directional XCVR, is switched through the EPLD, and output to the microprocessor as CLK 8.

**CROSSWIRED CABLE ASSEMBLY** – Recommended connectorized cable assembly – PN 695-7837-001 through -005 (26 AWG 8 pair shielded, jacketed cable with 15-pin D-type connector on each end). See Figure 3-32 for shelf connectors J308 and J309 location and pinout. Refer to Table 3-19 for J308 to J308 mating cable pinout and color code. See Figure 3-29 for typical connection scheme.

**DAISY CHAIN CABLE ASSEMBLY** – Recommended connectorized cable assembly – PN 695-7837-021 through -025 (26 AWG 8 pair shielded, jacketed cable with 15-pin D-type connector on each end, wired 1:1.) Refer to Table 3-20 for J309 to J308 mating cable pinout and color code. See Figure 3-29 for typical connection scheme.

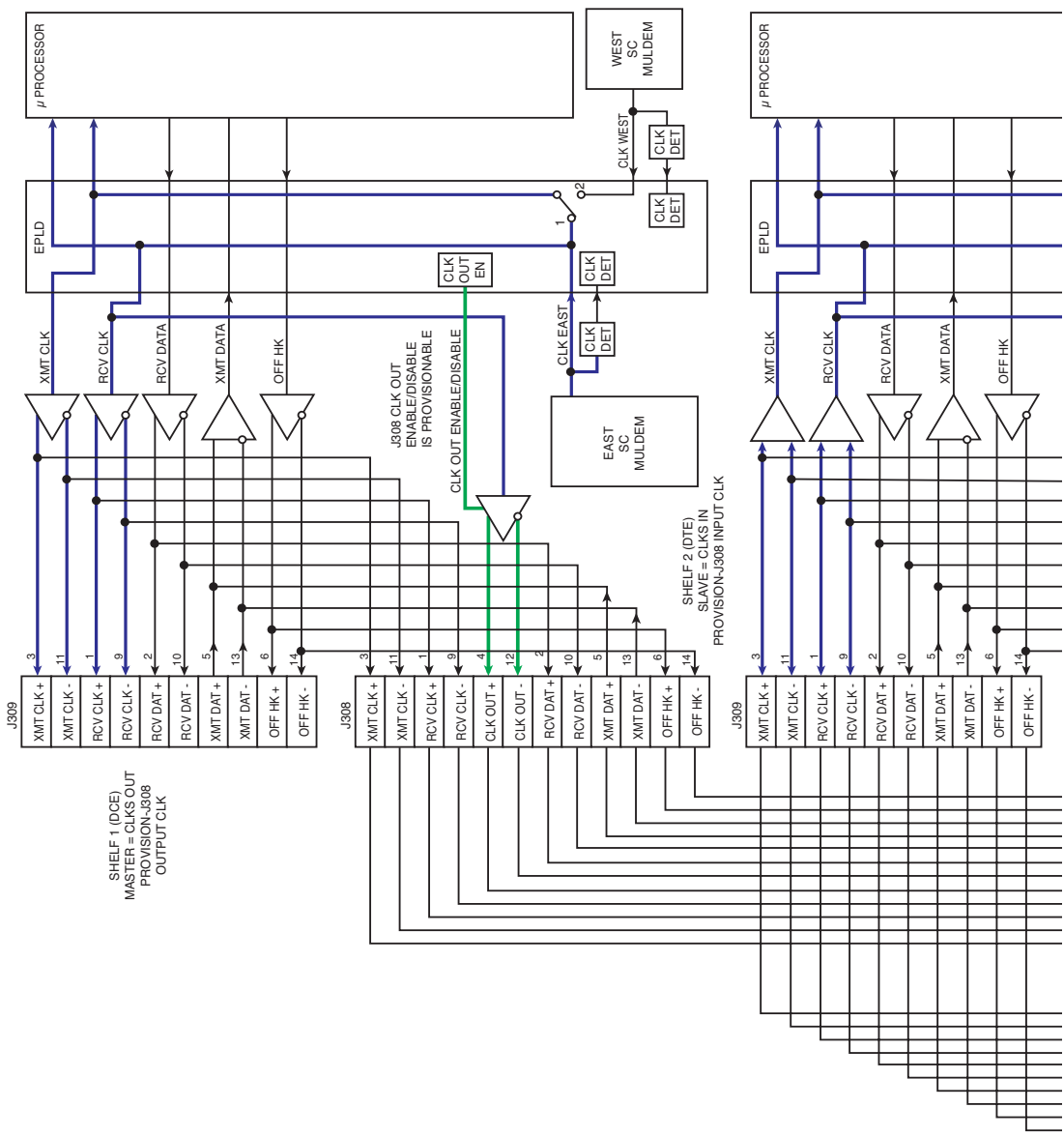
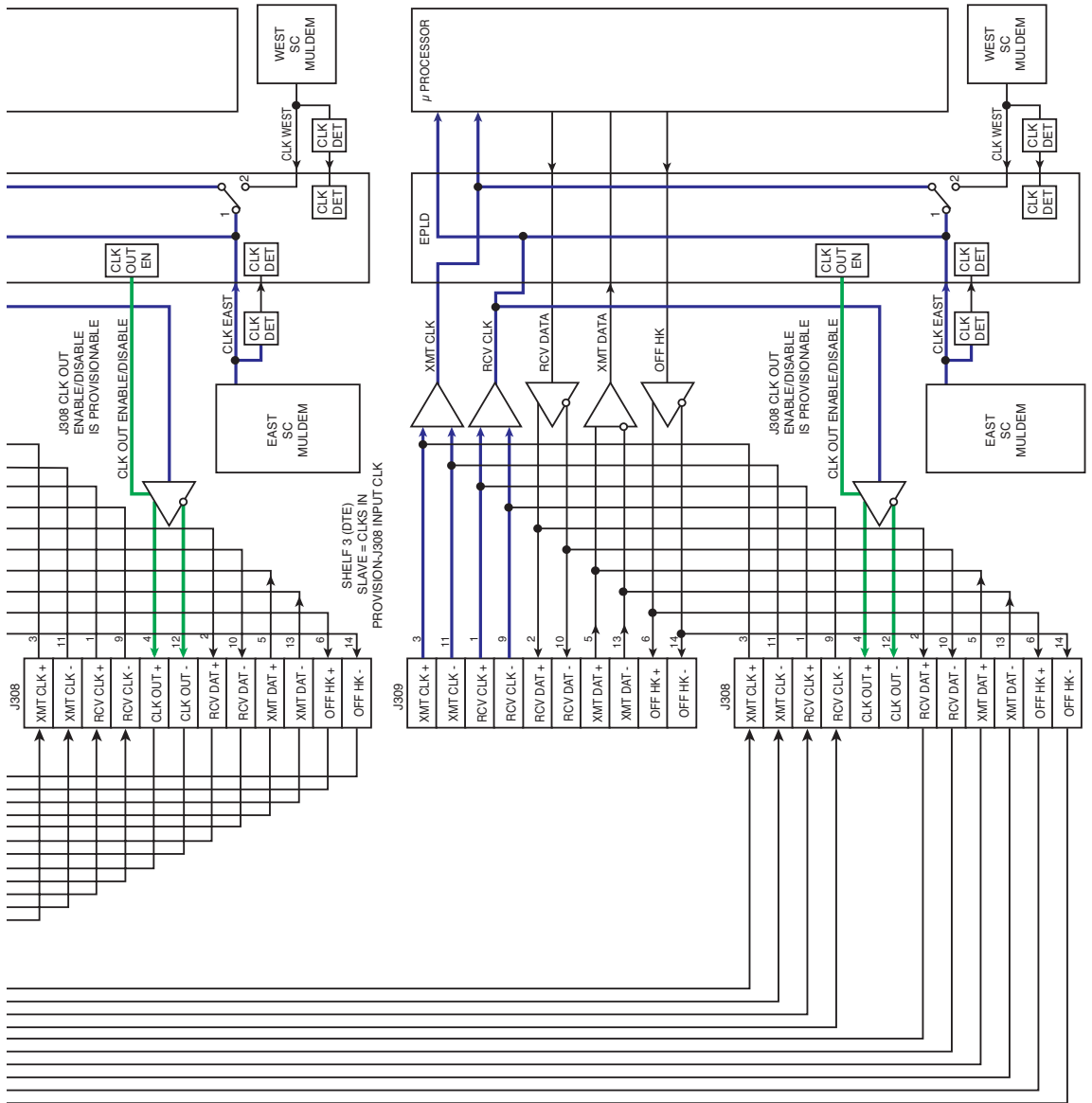
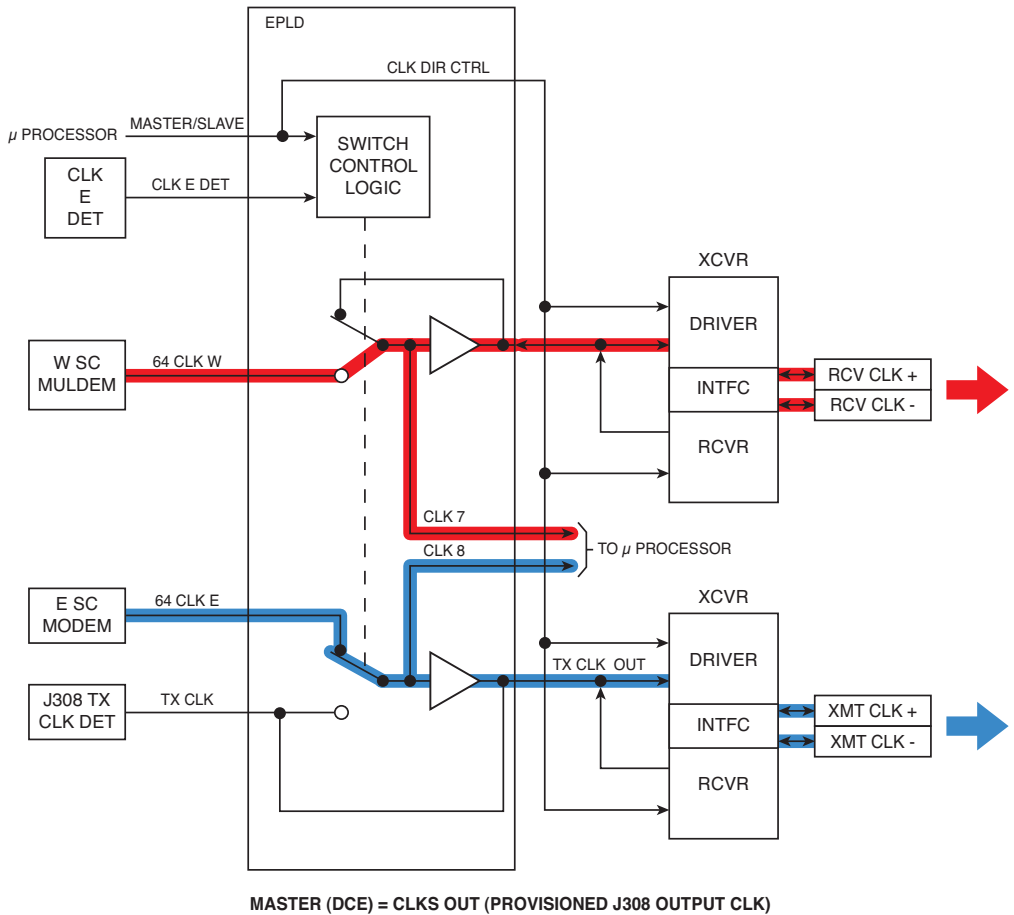

Figure 3-29 Typical MCS-11 Interconnect



MDR-1009  
02/02/07

### Typical Interconnect



NOTE:  
SOFTWARE CONTROLS ARE SHOWN AS PHYSICAL FOR SIMPLIFICATION.

MDR-1016A-F  
6/16/04

Figure 3-30 Master Mode Functional Block Diagram



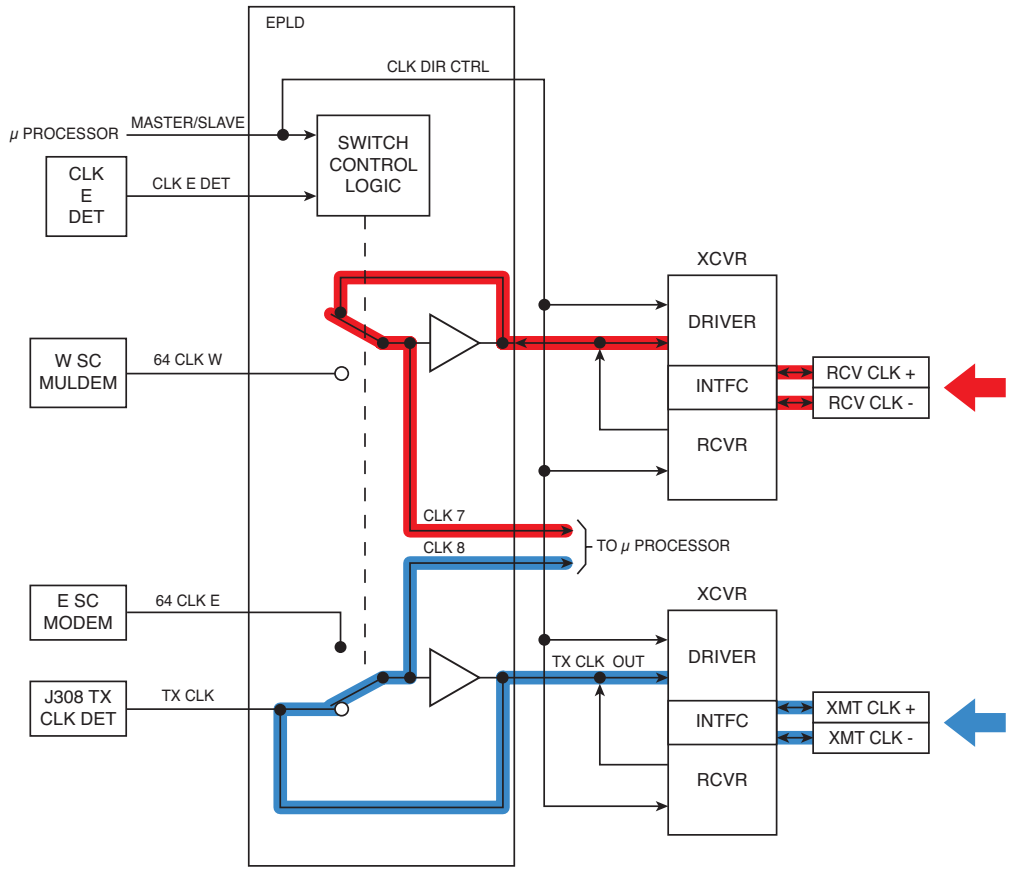

SLAVE (DTE) = CLKS IN (PROVISIONED J308 INPUT CLK)

NOTE:  
SOFTWARE CONTROLS ARE SHOWN AS PHYSICAL FOR SIMPLIFICATION.

MDR-1016-F  
5/13/05

Figure 3-31 Slave Mode Functional Block Diagram

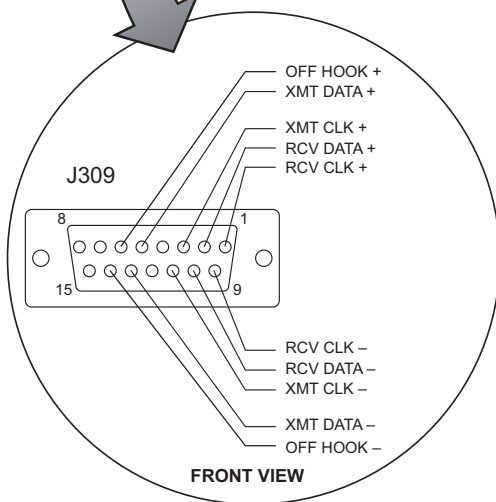
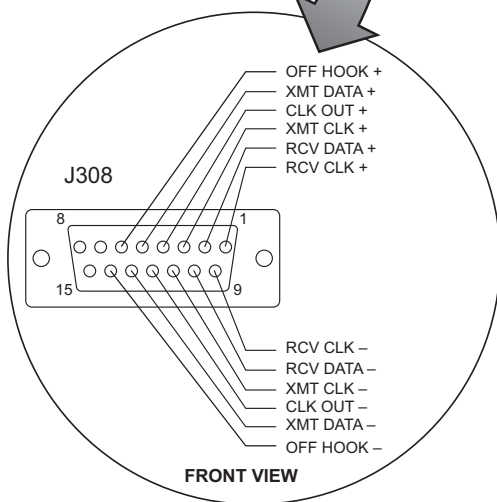
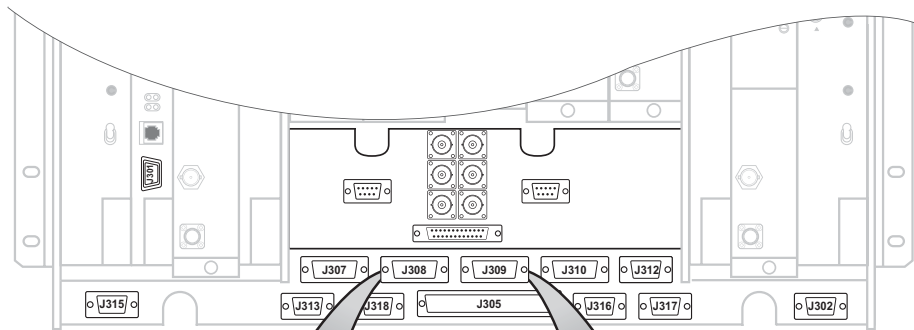

MDR-1011F  
04/12/04

Figure 3-32 MCS-11 Connectors J308 and J309 Location and Pinout

**Table 3-19 J308-to-J308 Mating Cable Wiring and Pinout**

J308 MDR-8000			J308/J308	J308 MDR-8000		
FUNCTION	END 1	WIRE COLOR	PAIR	WIRE COLOR	END 2	FUNCTION
RCV CLK +	01	BLACK	1	BLACK	03	XMT CLK +
RCV CLK-	09	RED		RED	11	XMT CLK-
RCV DATA +	02	BLACK	2	BLACK	05	XMT DATA +
RCV DATA -	10	WHITE		WHITE	13	XMT DATA -
XMT CLK +	03	BLACK	3	BLACK	01	RCV CLK +
XMT CLK -	11	GREEN		GREEN	09	RCV CLK -
CLK OUT+	04	BLACK	4	BLACK	04	NOT USED
CLK OUT -	12	BLUE		BLUE	12	NOT USED
XMT DATA +	05	BLACK	5	BLACK	02	RCV DATA +
XMT DATA -	13	YELLOW		YELLOW	10	RCV DATA -
OFF HOOK +	06	BLACK	6	BLACK	06	OFF HOOK +
OFF HOOK -	14	BROWN		BROWN	14	OFF HOOK -
NOT USED	07	BLACK	7	BLACK	07	NOT USED
NOT USED	15	ORANGE		ORANGE	15	NOT USED
NOT USED	08	RED	8	RED	08	NOT USED
NOT USED		WHITE		WHITE		NOT USED

**Table 3-20 J309-to-J308 Mating Cable Wiring and Pinout**

309 MDR-8000			J309/J308	J308 MDR-8000		
FUNCTION	END 1	WIRE COLOR	PAIR	WIRE COLOR	END 2	FUNCTION
RCV CLK +	01	BLACK	1	BLACK	01	RCV CLK +
RCV CLK-	09	RED		RED	09	RCV CLK-
RCV DATA +	02	BLACK	2	BLACK	02	RCV DATA +
RCV DATA -	10	WHITE		WHITE	10	RCV DATA -
XMT CLK +	03	BLACK	3	BLACK	03	XMT CLK +
XMT CLK -	11	GREEN		GREEN	11	XMT CLK -
CLK OUT+	04	BLACK	4	BLACK	04	NOT USED
CLK OUT -	12	BLUE		BLUE	12	NOT USED
XMT DATA +	05	BLACK	5	BLACK	05	XMT DATA +
XMT DATA -	13	YELLOW		YELLOW	13	XMT DATA -
OFF HOOK +	06	BLACK	6	BLACK	06	OFF HOOK +
OFF HOOK -	14	BROWN		BROWN	14	OFF HOOK -
NOT USED	07	BLACK	7	BLACK	07	NOT USED
NOT USED	08	ORANGE		ORANGE	15	NOT USED
NOT USED	15	RED	8	RED	08	NOT USED
NOT USED	16	WHITE		WHITE	16	NOT USED

### 3.18.3 MCS-11 Spur Connection (J310)

MCS-11 connector J310 can be used to connect to a spur shelf and is the preferred connection to the external DMX-3003N MUX. When connecting to a MDR-4000e or MDR-6000 radio use J310 on all of the radios for best results.

Recommended connectorized cable assembly – PN 695-4126-031 through -035 (26 AWG 8 pair shielded, jacketed cable with 15-pin D-type connector on each end). See Figure 3-33 for shelf connector J310 location and pinout. Refer to Table 3-21 for mating cable wiring and color code. See Figure 3-28 for typical connection scheme.

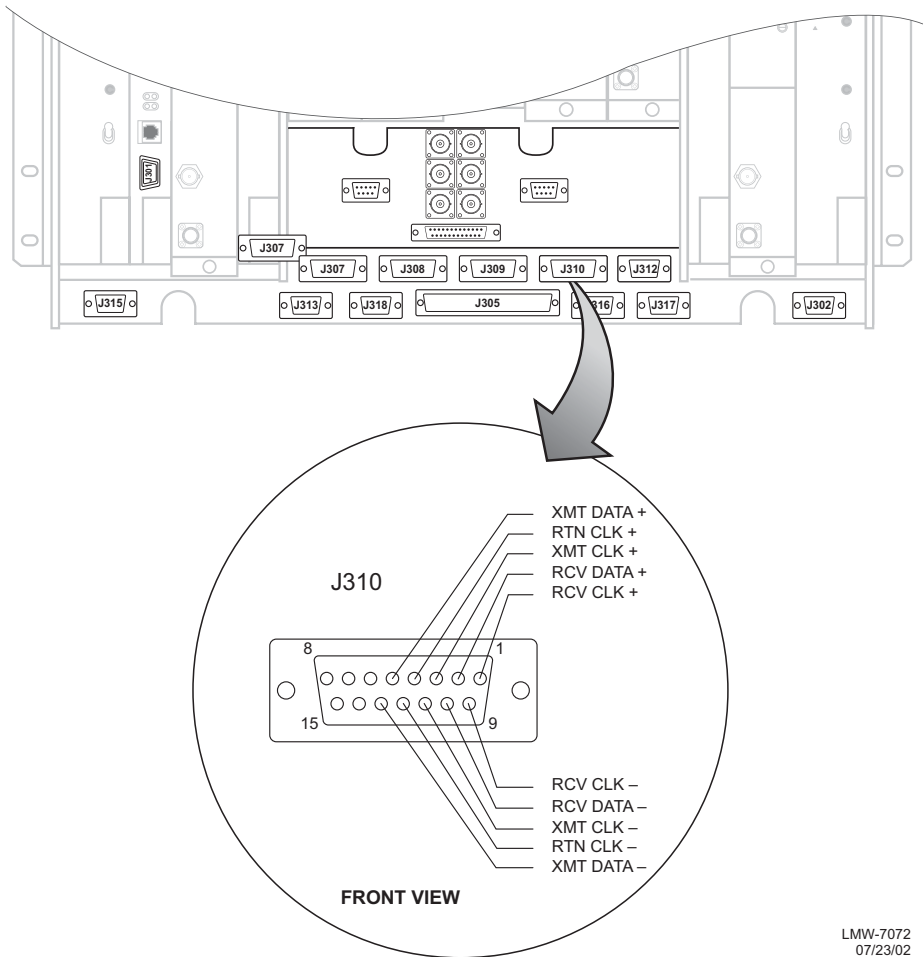

LMW-7072  
 07/23/02

Figure 3-33 MCS-11 Spur Connector J310 Location and Pinout

**Table 3-21 MCS-11 Spur Connector J310 Mating Cable Wiring and Pinout**

J310 MDR-8000			J310/J310	J310 MDR-8000		
FUNCTION	END 1	WIRE COLOR	PAIR	WIRE COLOR	END 2	FUNCTION
RCV CLK +	01	BLACK	1	BLACK	04	RETURN CLK +
RCV CLK-	09	RED	1	RED	12	RETURN CLK-
RCV DATA +	02	BLACK	2	BLACK	05	XMT DATA +
RCV DATA -	10	WHITE	2	WHITE	13	XMT DATA -
XMT CLK +	03	BLACK	3	BLACK	03	XMT CLK +
XMT CLK -	11	GREEN	3	GREEN	11	XMT CLK -
RETURN CLK +	04	BLACK	4	BLACK	01	RCV CLK +
RETURN CLK -	12	BLUE	4	BLUE	09	RCV CLK -
XMT DATA +	05	BLACK	5	BLACK	02	RCV DATA +
XMT DATA -	13	YELLOW	5	YELLOW	10	RCV DATA -
NOT USED	06	BLACK	6	BLACK	06	NOT USED
NOT USED	14	BROWN	6	BROWN	14	NOT USED
NOT USED	07	BLACK	7	BLACK	07	NOT USED
NOT USED	15	ORANGE	7	ORANGE	15	NOT USED
NOT USED	08	RED	8	RED	08	NOT USED
NOT USED	16	WHITE	8	WHITE	16	NOT USED

### 3.19 TMN CONNECTIONS

This section gives the location and description of customer connections on the TMN interface module.

#### 3.19.1 Installing Module

- 1 Connect mating cables to applicable connectors J1-J4.
- 2 Install TMN Interface module loosely in slot C3 in MDR-8000 shelf.
- 3 Route cables through slot in module front panel, leaving a service loop in the space below.
- 4 Limit the number of cable ties to prevent having to use large service loops. Leave a service loop of ten in. minimum for future access to cable connectors and module extraction.
- 5 Press top and bottom handles to seat module in backplane connector.
- 6 Go to Initial Turnup section for initial turnup procedures.

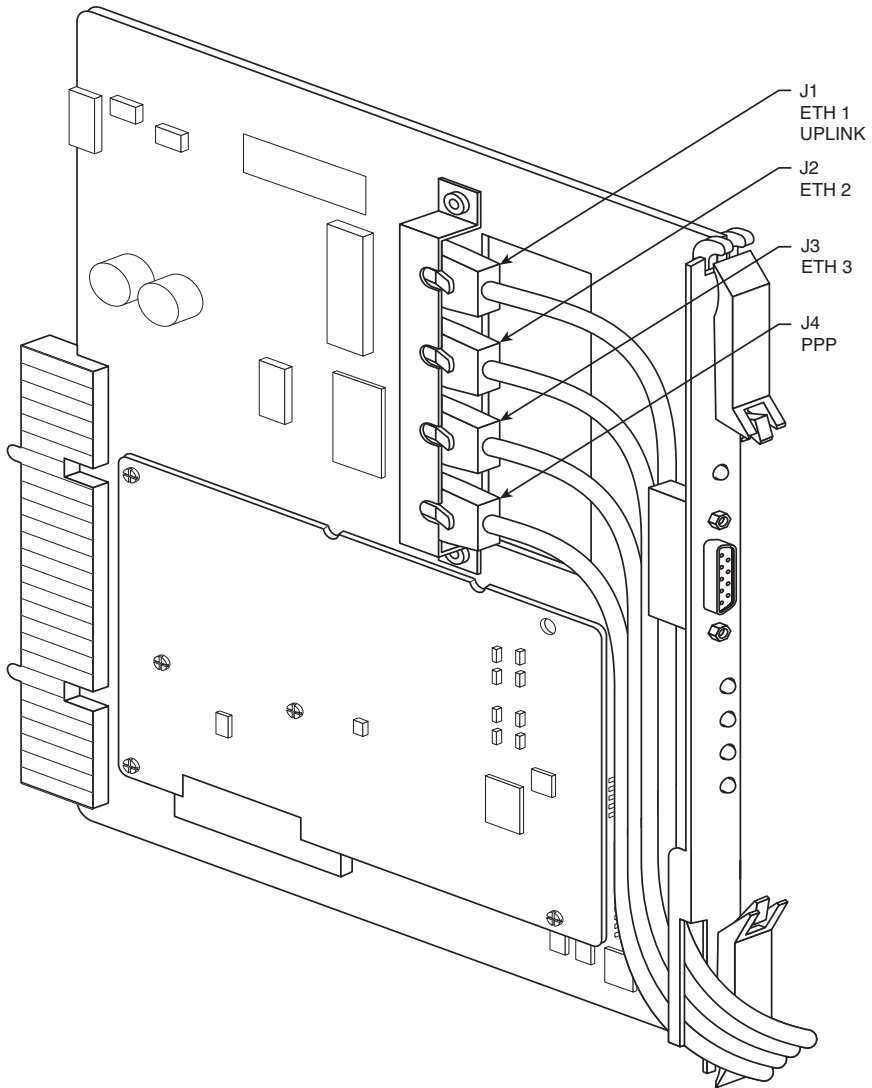

Figure 3-34 TMN Interface Module Signal Connections

## 3.19.2 Typical Interconnect Scenarios

**Note**

*Refer to CD, Connecting MDR-8000 Radio TMN Interface in an Ethernet LAN, for limitations on interconnecting radios and equipment at a site.*

### 3.19.2.1 Scenario 1 – Daisy Chain, Bridged Connection

See Figure 3-35. In this scenario, four TMN interface modules are connected to the LAN. Daisy chaining prevents having to use external equipment to connect to the LAN. Daisy chaining is typically used instead of a costly battery powered switch/hub at smaller junction stations and/or battery powered remote sites where ac power is not available.

This is accomplished using the Uplink (U) ports on the TMN interface modules on shelves 2 and 3 to connect to the TMN interface module in shelf 1. The uplink port on the TMN interface module in shelf 3 connects to the Ethernet 2 port TMN interface module in shelf 2.

### 3.19.2.2 Scenario 2 – Switched Connection

See Figure 3-36. In this scenario, four TMN interface modules are connected to the LAN via a switch/hub using the Ethernet uplink port on each module. Ethernet 2 or 3 could be used with a crossover cable.

**Note**

*Since many switch/hubs are powered by ac, this scheme is typically used at terminals where ac power is accessible.*

### 3.19.2.3 Scenario 3 – Front PPP Port Connections

For TMN to TMN PPP connections from Normal (DCE) to Crossover (DTE) or vice-versa, use standard Cat. 5 cable. For other PPP connection options see Figure 3-37 and Figure 3-38.



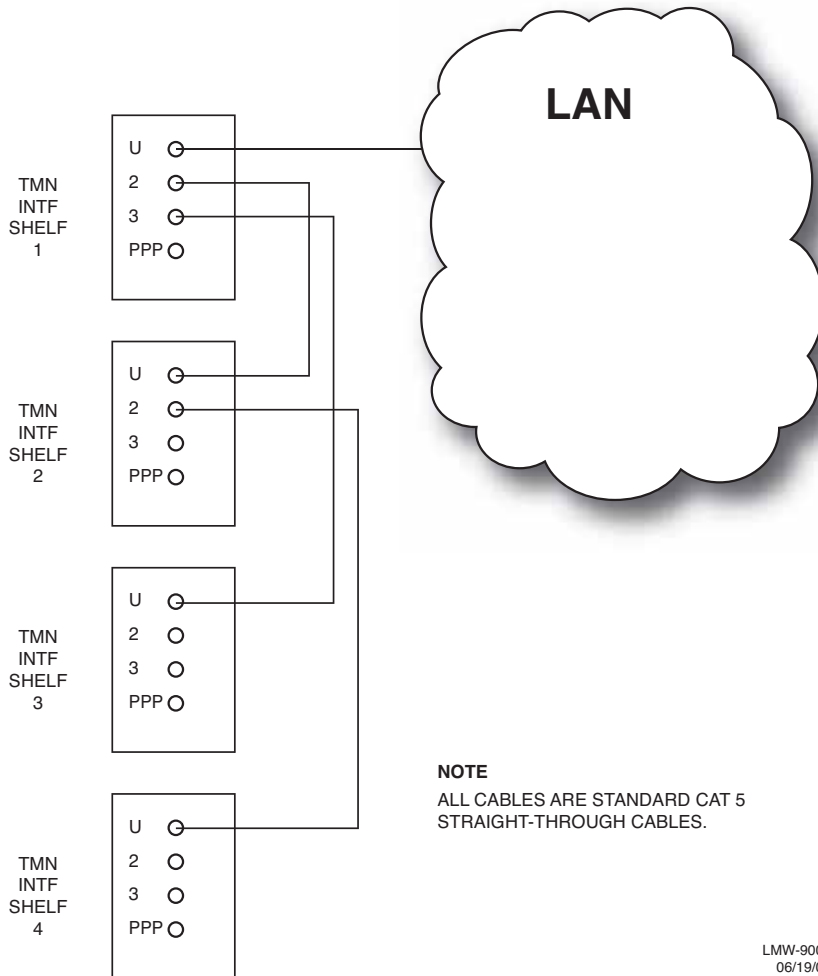

Figure 3-35 Daisy Chain, Using Internal Repeating Hub

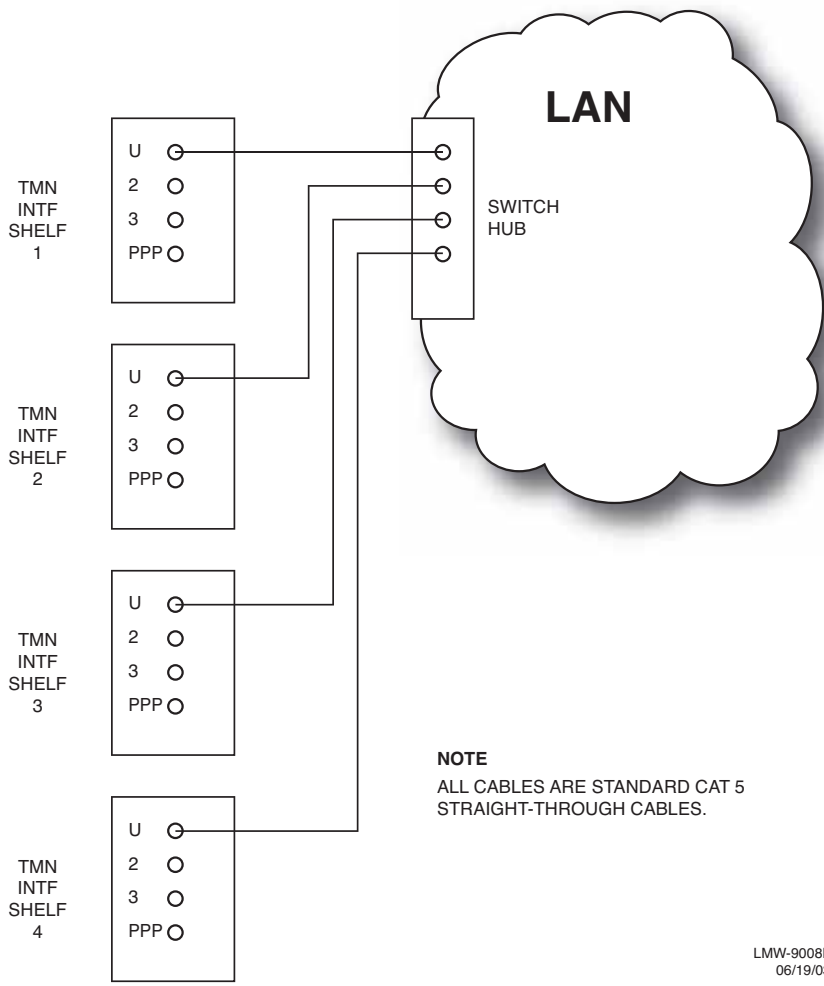

Figure 3-36 Switched Connection Using External Switch/Hub

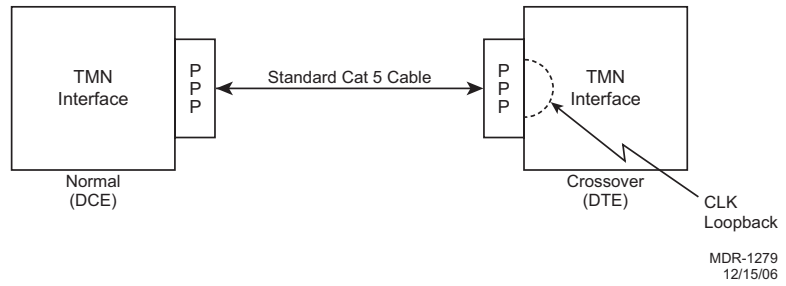
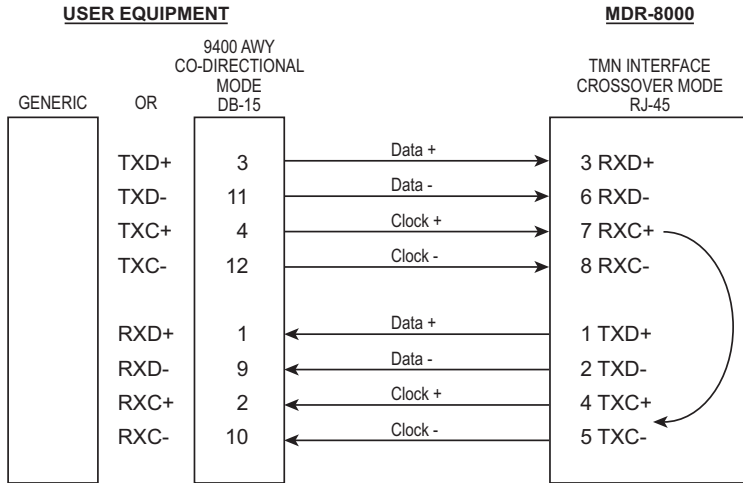
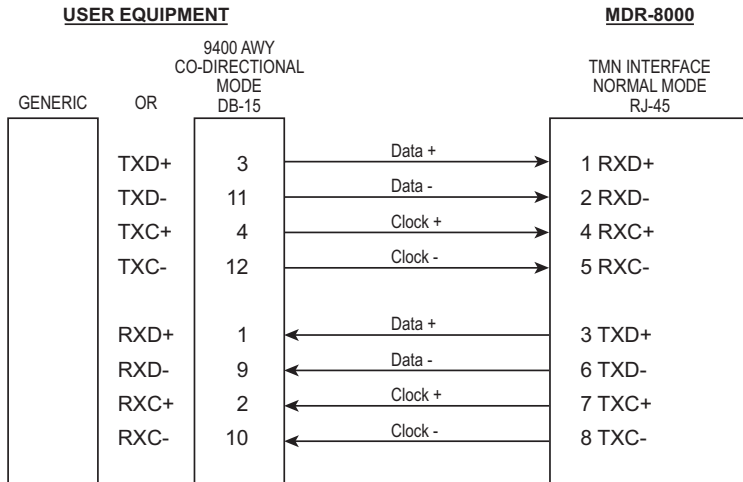

Figure 3-37 Front PPP Port TMN to TMN Connection



In Crossover mode, the Received Clock is used to time the Transmitted data, and the interface is synchronous with the external equipment.



In Normal mode, the functions of the pins reverse, the clock from the user equipment is used to time the incoming data, and an internal clock is used to time the outgoing data making the interface fully asynchronous.

**GENERIC OR 9400 AWY TO TMN**

MDR-1280  
12/15/06

**Figure 3-38 Other Front PPP Port Connections (Sheet 1 of 2)**

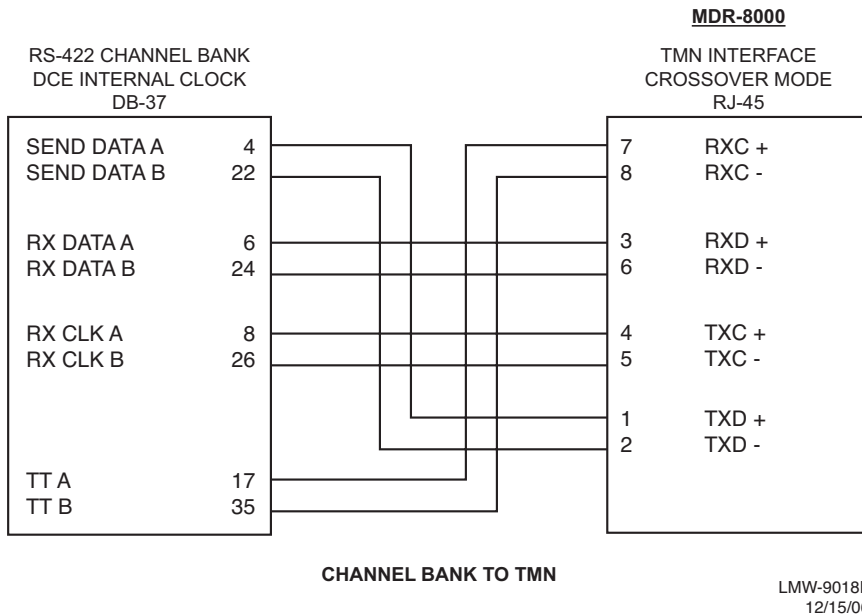

Figure 3-38 Other Front PPP Port Connections (Sheet 2 of 2)

### 3.19.3 Front Access Connectors

Front access connectors include ETH1 Uplink connector J1, ETH2 connector J2, ETH3 connector J3, and PPP connector J4. Refer to the following paragraphs for details.

**Note**

*See Figure 3-39. To determine which wire is number 1 on the RJ-45 connector on the mating cable, hold the cable so that the end of the plastic tip is facing away from you (the copper pins are facing up and the plastic spring lock s=clip is underneath). When looking down on the copper pins, pin number 1 is on the far left.*

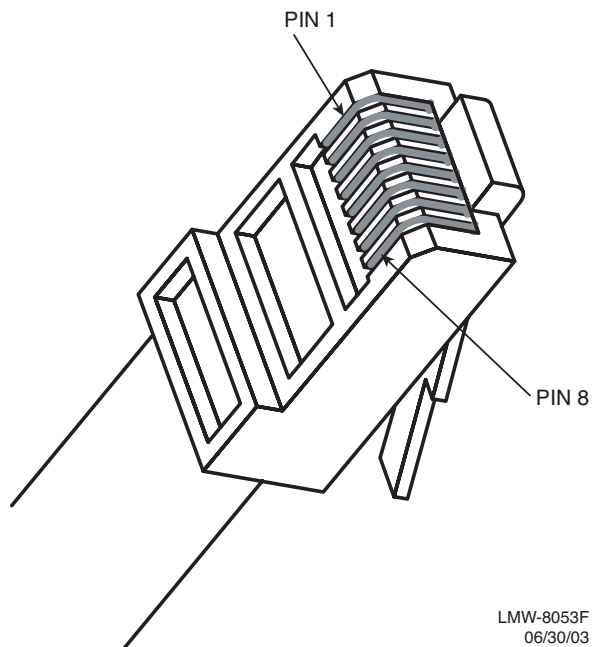

Figure 3-39 Typical RJ-45 Connector Pinout

### 3.19.3.1 Ethernet (ETH) 1 Uplink Connector J1

Uplink connector J1 is crosswired internally. Use a straight-through cable for connecting to hub or other equipment. Refer to Table 3-22 for module connector pinout.

Table 3-22 ETH1 Uplink Connector J1 Pinout

PIN	FUNCTION
1	TX+
2	TX-
3	RX+
4/5	GND (via 75 ohm resistor)
6	RX-
7/8	GND (via 75 ohm resistor)

### 3.19.3.2 Ethernet Connectors J2 and J3

ETH2 and ETH3 connectors require straight-through cables to connect to external equipment. Refer to Table 3-23 for pinout/function.

Table 3-23 ETH2 and ETH3 Connectors J2 and J3 Pinout

PIN	FUNCTION
1	RX+
2	RX+
3	TX+
4/5	GND (via 75 ohm resistor)
6	TX-
7/8	GND (via 75 ohm resistor)

### 3.19.3.3 PPP Connector J4

Proposed wiring compatible with TIA-568B on an RJ45 connector. Using this pinout, MDR-8000 radios could be interconnected using a standard four twisted pair (8 wire) straight-through wired CAT5 Ethernet Crossover patch cord, provided that the clocks port on one end is provisioned to *receive clock* instead of *transmit clock*. Refer to Table 3-24 for pinout/function.

Table 3-24 PPP Connector J4 Pinout

PIN	FUNCTION	DTE	DCE
1	TXDAP	OUT	IN
2	TXDAN	OUT	IN
3	RXDAP	IN	OUT
5	TXCAP	OUT	IN
6	RXDAN	IN	OUT
7	RXCAP	IN	OUT
8	RXCAN	IN	OUT

### 3.19.4 MATING CABLES

See Figure 3-40 and Figure 3-41. Part numbers are assigned for CAT5 UTP straight and crossover unshielded and shielded cables as follows:

PN 3AL48960AAAAAADSZZA straight-through, unshielded

PN 3AL48956AAAAAADSZZA straight-through, shielded

PN 3AL48961AAAAAADSZZA crossover, unshielded

PN 3AL48962AAAAAADSZZA crossover, shielded

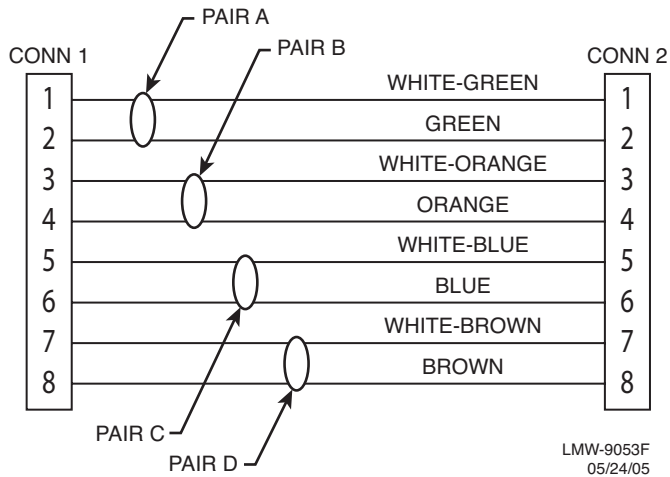

Figure 3-40 Straight-Through Mating Cable

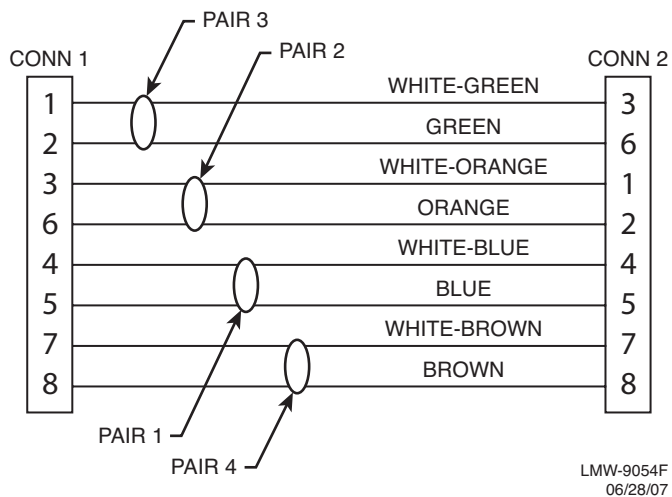

Figure 3-41 Crossover Mating Cable

### 3.19.5 Front Panel Craft Interface Connector J5

The CRAFT J5 connector on the front panel is used to interface the TMN interface module with a PC. The CRAFT interface is an RS-232-compatible DCE interface, DB9 male to DB9 female cable, PN 695-7848. Refer to Table 3-25 for connector pinout/function. Refer to Table 3-26 for mating cable pinout/function. See Figure 3-42 for location/pinout details.

Table 3-25 CRAFT Terminal Connector J5 Pinout

PIN	FUNCTION
1	DCD
2	TXD
3	RXDD
4	DTR
5	GND
6	DSR
7	NC
8	NC
9	NC

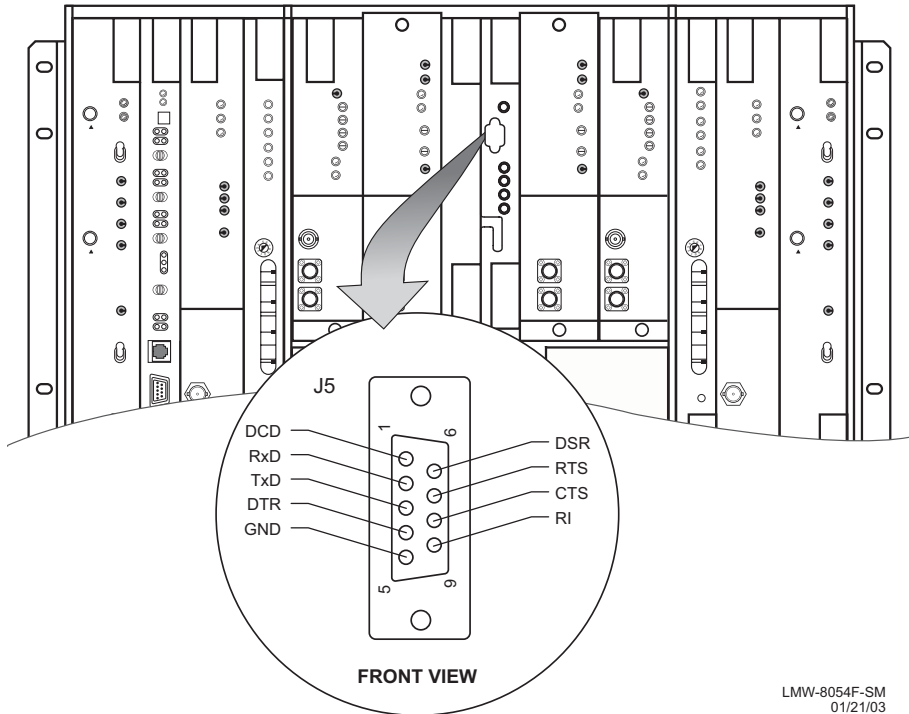

LMW-8054F-SM  
01/21/03

Figure 3-42 CRAFT Terminal Connector J5 Location and Pinout



**Table 3-26 J5 Straight-Through Mating Cable**

FUNCTION	END 1	WIRE COLOR	END 2	FUNCTION
DCD	01	BLACK	01	DCD
TXD	02	RED	02	TXD
RXD	03	BLACK	03	RXD
DTR	04	WHITE	04	DTR
GND	05	BLACK	05	GND
DTR	06	GREEN	06	DTR
NC	07	BLACK	07	NC
NC	08	BLUE	08	NC
NC	09	BLACK	09	NC

### 3.20 ELMC (J315, J318)

As a standard feature, the Extended Link Monitor Channel (ELMC) function allows local provisioning, alarms, status information, and control commands for the local radio and, (with the exception of wayside DS1), alarms, status information, control for addressable remote radios. For wayside DS1 status, the ELMC option key (695-5647-019 or -020) must be installed on the AE-37Y Controller. For remote provisioning and downloading capability, the ELMC option key (695-5647-018 or 695-5647-020) must be installed on the AE-37Y Controller. Refer Table 3-27 for details.

Recommended connectorized cable assembly – PN 695-4125-006/013 (26 AWG 5 pair shielded, jacketed cable). See Figure 3-43 for shelf connectors locations and pinout. Refer to Table 3-28 for mating cable wiring and color code. See Figure 3-44 for typical connection scheme.

**Table 3-27 ELMC Option Keys**

ELMC Option Key	695-5647-018	Required for remote provisioning and downloading on DS1/E1 radios, and DS3 and OC3/STM-1 radios without wayside DS1
ELMC Option Key	695-5647-019	Required for status of DS3 and OC3/STM-1 radios with wayside DS1 (no remote provisioning or download capability provided)
ELMC Option Key	695-5647-020	Required for remote provisioning and downloading of DS3 and OC3/STM-1 radios with wayside DS1

**Note**

*ELMC 1 connector J318 and ELMC 2 connector J315 are wired in parallel. You can connect J315 to J315, J315 to J318, or J318 to J318. A typical connection scheme is shown.*

Table 3-28 ELMC Connector J315/J318 Mating Cable Wiring and Pinout

J315/J318 MDR-8000				J315/J318 MDR-8000		
FUNCTION	END 1	WIRE COLOR	PAIR	WIRE COLOR	END 2	FUNCTION
RCV+	01	BLACK	1	BLACK	02	XMT+
RCV-	06	RED		RED	07	XMT-
XMT+	02	BLACK	2	BLACK	01	RCV+
XMT-	07	WHITE		WHITE	06	RCV-
NOT USED		BLACK	3	BLACK		NOT USED
GND	03	GREEN		GREEN	03	GND
NOT USED	04	BLACK	4	BLACK	05	NOT USED
NOT USED	08	BLUE		BLUE	09	NOT USED
NOT USED	05	BLACK	5	BLACK	04	NOT USED
NOT USED	09	YELLOW		YELLOW	08	NOT USED

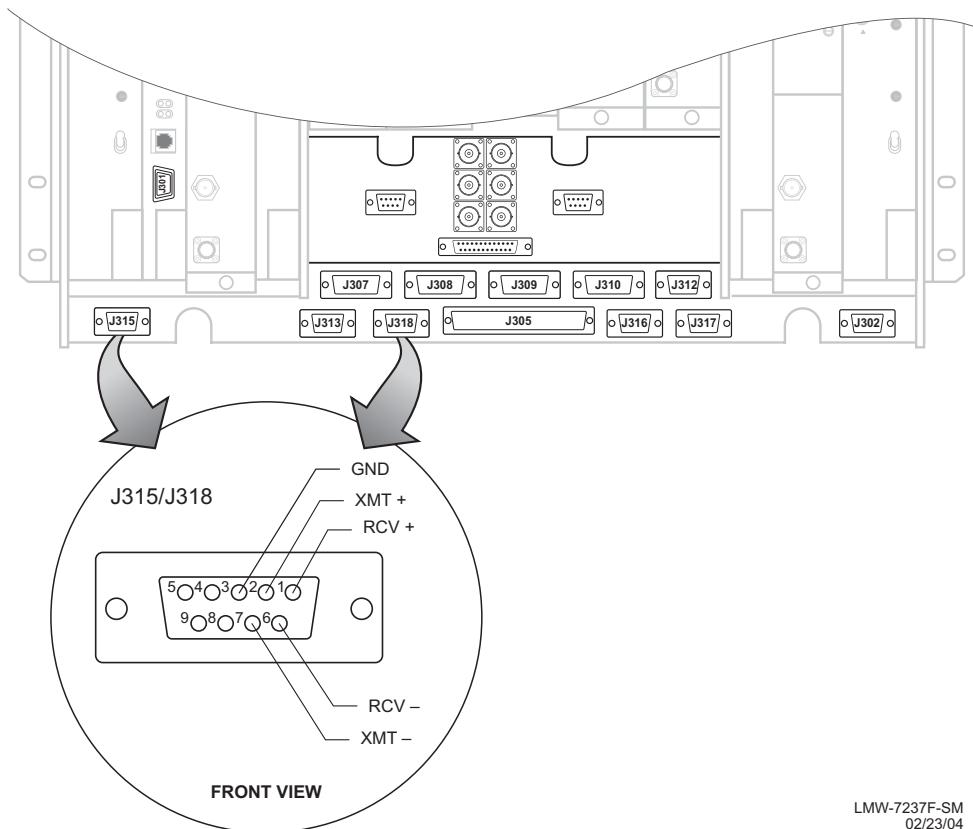

LMW-7237F-SM  
02/23/04

Figure 3-43 ELMC Connectors Location and Pinout

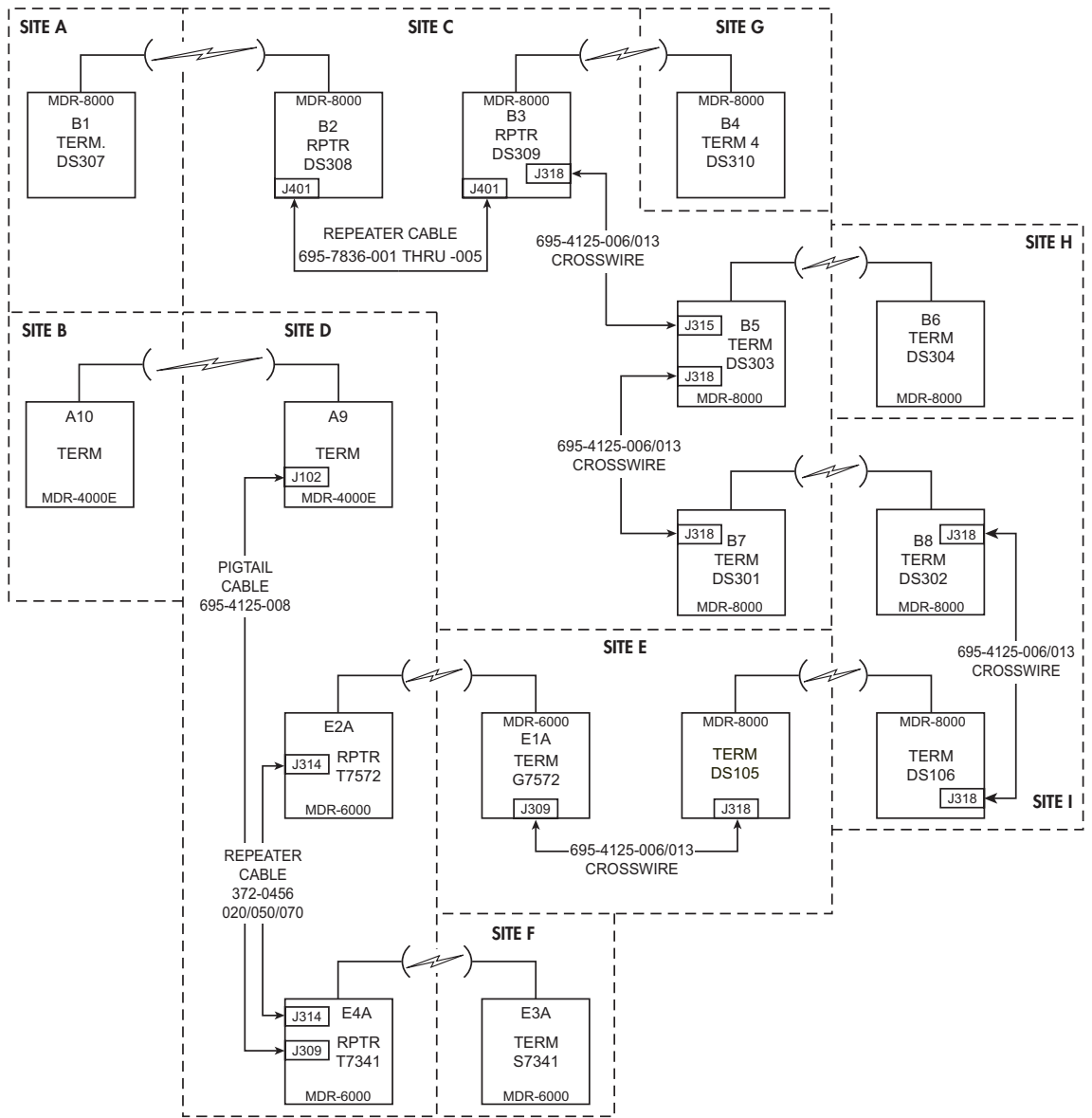

**Note**

When connecting MDR-8000 radios with Windows USI to radios with DOS USI, check the DOS USI ELMC address for space, dash, slash, asterisk, or underscore. The Windows USI cannot recognize a space, dash, slash, asterisk, or underscore. Change the DOS ELMC address to a 5-character alphanumeric address without the prohibited characters.

MDR-1026F  
06/12/04

Figure 3-44 Typical ELMC Connections

### 3.21 FOREIGN ALARM INTERFACE (J305)

Recommended connectorized cable assembly – PN 695-4121-001/003 (24 AWG 25 pair cable). See Figure 3-45 for shelf connector location and pinout. Refer to Table 3-29 for mating cable pinout and color code.

or

Recommended wirewrap cable – PN 424-0429-020 (22 AWG 30-pair twisted cable) for use with wirewrap adapter PN 695-4171-002. Refer to Table 3-29 for pinout.

**Note**

*TBOS connections on J305 share pins with station alarms 13 through 16 and either TBOS or station alarms 13 through 16 is selected (provisioned) on the USI Radio Configuration Provisioning screen.*

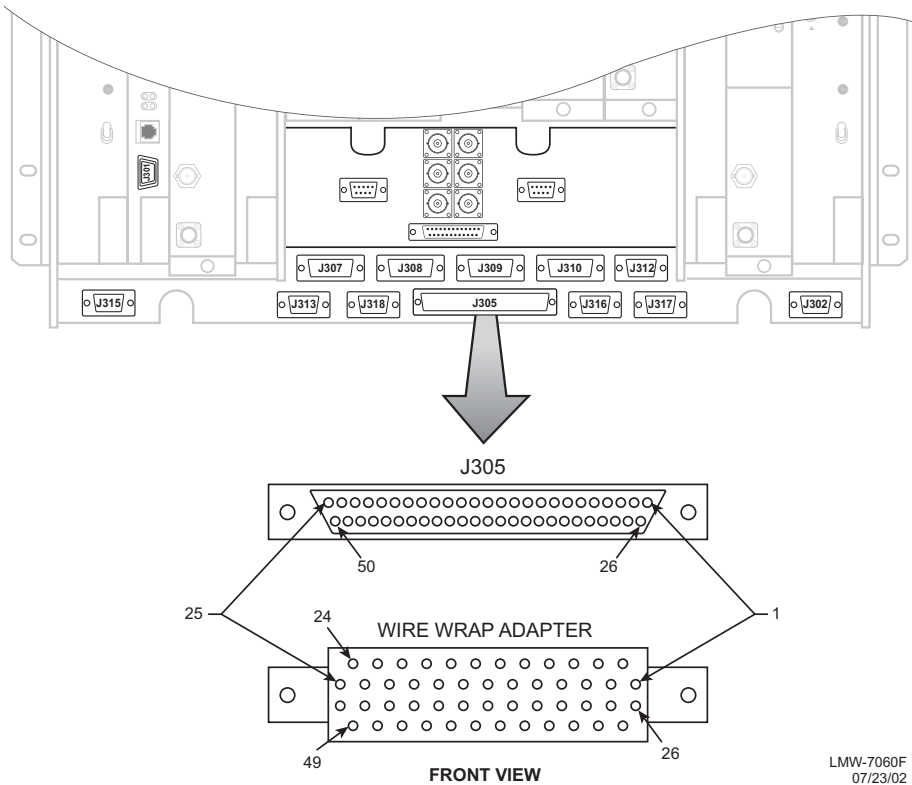

LMW-7060F  
07/23/02

Figure 3-45 Alarm/Status/TBOS Connector J305 Location and Pinout

**Table 3-29 Alarm/Status Connector J305 Mating Cable Wiring and Pinout**

ALM/STATUS/CONTROL	PIN	PR	WIRE COLOR	REMARKS
A XMT ALM OUT	01	1	WHT/BLU	ALARM OUTPUT FROM RELAY INTFC
B XMT ALM OUT	26		BLU/WHT	ALARM OUTPUT FROM RELAY INTFC
A RCV ALM OUT	02	2	WHT/ORN	ALARM OUTPUT FROM RELAY INTFC
B RCV ALM OUT	27		ORN/WHT	ALARM OUTPUT FROM RELAY INTFC
CONTROLLER FAIL ALM OUT	03	3	WHT/GRN	ALARM OUTPUT FROM RELAY INTFC
SWITCH I/O OUT	28		GRN/WHT	CONTROL OUTPUT FROM RELAY INTFC
SWITCH XMTR OUT	04	4	WHT/BRN	CONTROL OUTPUT FROM RELAY INTFC
SWITCH RCVR OUT	29		BRN/WHT	CONTROL OUTPUT FROM RELAY INTFC
A XMT IN SVCE OUT	05	5	WHT/SLT	STATUS OUTPUT FROM RELAY INTFC
B XMT IN SVCE OUT	30		SLT/WHT	STATUS OUTPUT FROM RELAY INTFC
A RCV IN SVCE OUT	06	6	RED/BLU	STATUS OUTPUT FROM RELAY INTFC
B XMT IN SVCE OUT	31		BLU/RED	STATUS OUTPUT FROM RELAY INTFC
A I/O IN SVCE OUT	07	7	RED/ORN	STATUS OUTPUT FROM RELAY INTFC
B I/O IN SVCE OUT	32		ORN/RED	STATUS OUTPUT FROM RELAY INTFC
PWR SUPPLY ALM OUT	08	8	RED/GRN	ALARM OUTPUT FROM RELAY INTFC
NOT USED/OPEN DOOR FAULT	33		GRN/RED	ALARM OUTPUT ON COMM PAK ONLY
STATION ALM 9 IN	09	9	RED/BRN	RELAY INPUT FROM CUSTOMER EQUIPMENT
STATION ALM 1 IN	34		BRN/RED	RELAY INPUT FROM CUSTOMER EQUIPMENT
STATION ALM 10 IN	10	10	RED/SLT	RELAY INPUT FROM CUSTOMER EQUIPMENT
STATION ALM 2 IN	35		SLT/RED	RELAY INPUT FROM CUSTOMER EQUIPMENT
STATION ALM 11 IN	11	11	BLK/BLU	RELAY INPUT FROM CUSTOMER EQUIPMENT
STATION ALM 3 IN	36		BLU/BLK	RELAY INPUT FROM CUSTOMER EQUIPMENT
STATION ALM 12 IN	12	12	BLK/ORN	RELAY INPUT FROM CUSTOMER EQUIPMENT
STATION ALM 4 IN	37		ORN/BLK	RELAY INPUT FROM CUSTOMER EQUIPMENT

**Table 3-29 Alarm/Status Connector J305 Mating Cable Wiring and Pinout (Cont.)**

ALM/STATUS/CONTROL	PIN	PR	WIRE COLOR	REMARKS
TBOS XMT- DATA IN OR STATION ALM 13 IN	13	13	BLK/GRN	SERIAL DATA INPUT TO RADIO CONTROLLER OR RELAY INPUT FROM CUSTOMER EQUIPMENT TO RELAY INTFC CARD (PROVISIONABLE)
STATION ALM 5 IN	38	13	GRN/BLK	INPUT FROM CUSTOMER EQUIPMENT
TBOS XMT+ DATA IN OR STATION ALM 14 IN	14	14	BLK/BRN	SERIAL DATA INPUT TO RADIO CONTROLLER OR RELAY INPUT FROM CUSTOMER EQUIPMENT TO RELAY INTFC CARD (PROVISIONABLE)
STATION ALM 6 IN	39		BRN/BLK	INPUT FROM CUSTOMER EQUIPMENT
TBOS RCV- DATA OUT OR STATION ALM 15 IN	15	15	BLK/SLT	SERIAL DATA OUTPUT FROM RADIO CONTROLLER OR RELAY INPUT FROM CUSTOMER EQUIPMENT TO RELAY INTFC CARD (PROVISIONABLE)
STATION ALM 7 IN	40		SLT/BLK	INPUT FROM CUSTOMER EQUIPMENT
TBOS RCV+ DATA OUT OR STATION ALM 16 IN	16	16	YEL/BLU	SERIAL DATA OUTPUT FROM RADIO CONTROLLER OR RELAY INPUT FROM CUSTOMER EQUIPMENT TO RELAY INTFC CARD (PROVISIONABLE)
STATION ALM 8 IN	41		BLU/YEL	RELAY INPUT FROM CUSTOMER EQUIPMENT
CONTROL 1 OUT	17	17	YEL/ORN	OUTPUT TO CUSTOMER EQUIPMENT
CONTROL STATUS 1 IN	42		ORN/YEL	INPUT FROM CUSTOMER EQUIPMENT IN RESPONSE TO CONTROL 1 OUTPUT
CONTROL 2 OUT	18	18	YEL/GRN	OUTPUT TO CUSTOMER EQUIPMENT
CONTROL STATUS 2 IN	43		GRN/YEL	INPUT FROM CUSTOMER EQUIPMENT IN RESPONSE TO CONTROL 2 OUTPUT
CONTROL 3 OUT	19	19	YEL/BRN	OUTPUT TO CUSTOMER EQUIPMENT
CONTROL STATUS 3 IN	44		BRN/YEL	INPUT FROM CUSTOMER EQUIPMENT IN RESPONSE TO CONTROL 3 OUTPUT
CONTROL 4 OUT	20	20	YEL/SLT	OUTPUT TO CUSTOMER EQUIPMENT
CONTROL STATUS 4 IN	45		SLTYEL	INPUT FROM CUSTOMER EQUIPMENT IN RESPONSE TO CONTROL 4 OUTPUT

**Table 3-29 Alarm/Status Connector J305 Mating Cable Wiring and Pinout (Cont.)**

ALM/STATUS/CONTROL	PIN	PR	WIRE COLOR	REMARKS
CONTROL 5 OUT	21	21	VIO/BLU	OUTPUT TO CUSTOMER EQUIPMENT
CONTROL STATUS 5 IN	46		BLU/VIO	INPUT FROM CUSTOMER EQUIPMENT IN RESPONSE TO CONTROL 5 OUTPUT
CONTROL 6 OUT	22	22	VIO/ORN	OUTPUT TO CUSTOMER EQUIPMENT
CONTROL STATUS 6 IN	47		ORN/VIO	INPUT FROM CUSTOMER EQUIPMENT IN RESPONSE TO CONTROL 6 OUTPUT
PATH ALM OUT	23	23	VIO/GRN	ALARM OUTPUT FROM RELAY INTFC
LOSS OF INPUT OUT	48		GRN/VIO	ALARM OUTPUT FROM RELAY INTFC
MAJOR ALM/VISUAL ALM OUT	24	24	VIO/BRN	ALARM OUTPUT FROM CONTROLLER (PROVISIONABLE MAJOR/MINOR OR VISUAL/AUDIBLE ON USI SCREEN)
RACK ALM RETURN	49		BRN/VIO	INPUT TO CONTROLLER
RACK ALM OUT	25	25	VIO/SLT	OUTPUT FROM CONTROLLER
MINOR ALM/AUDIBLE ALM OUT	50		SLT/VIO	ALARM OUTPUT FROM CONTROLLER (PROVISIONABLE MAJOR/MINOR OR VISUAL/AUDIBLE ON USI SCREEN)

### 3.22 ALARM, STATUS, AND CONTROLS INTERCONNECT

See Figure 3-46 for interconnect diagram. The AE-27( ) Relay Interface provides alarm, control and status inputs, and alarm, status and control relay outputs. All output relays can be disabled or provisioned normally open or normally closed as follows:

**Normally open (NO)** – relays are normally de-energized and relay contacts are open. When activated, relays are energized. Relay contacts close, connecting the output to ground.

**Normally closed (NC)** – relays are normally energized and relay contacts are closed and grounded. When activated, relays are de-energized. Relay contacts open, presenting an open (high impedance) to the output.

Rack ALM Return, Pin 49 is a ground point for use with Rack ALM Out. It is a signal ground (low current) not used for battery voltage or high current ground.

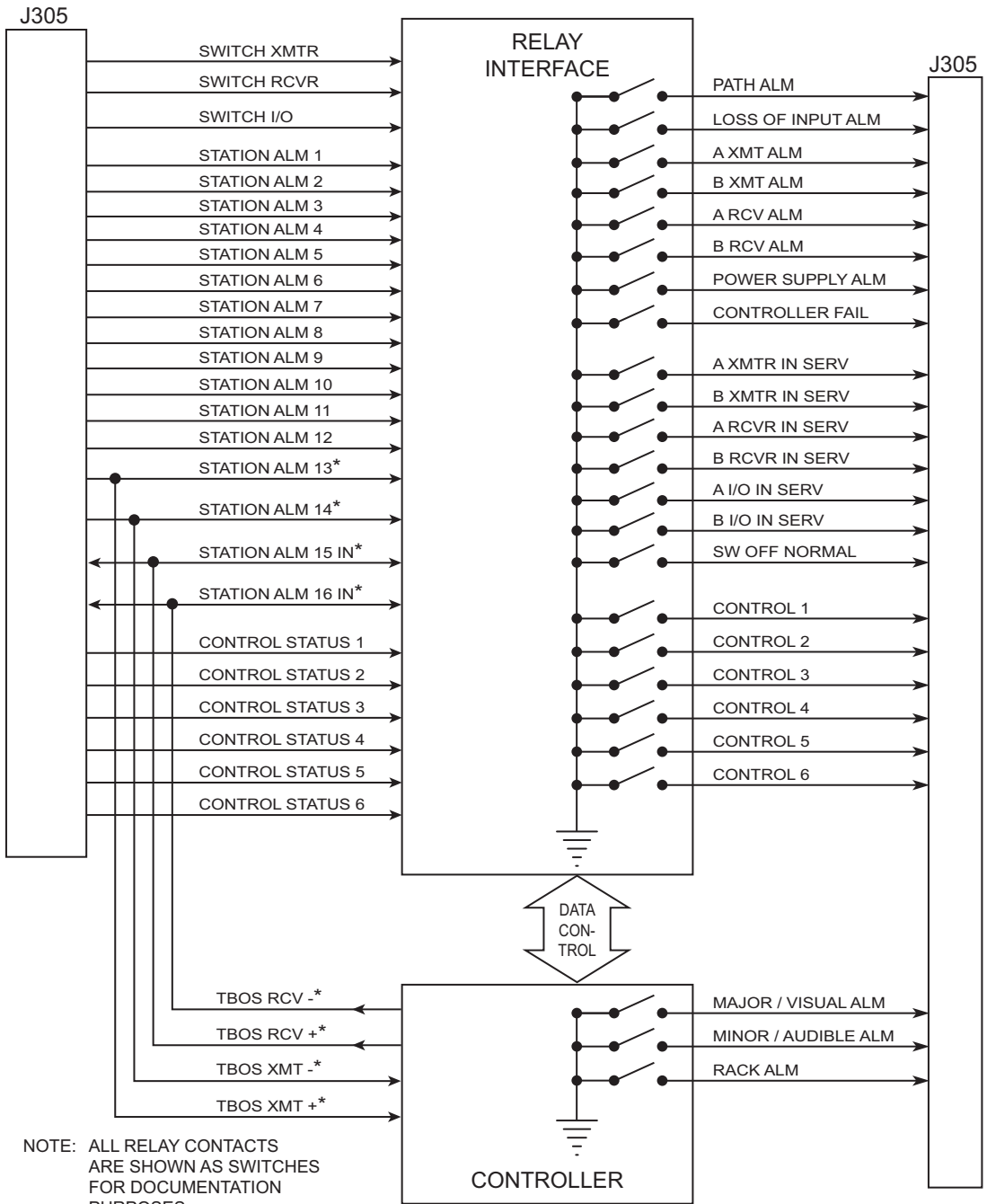

NOTE: ALL RELAY CONTACTS ARE SHOWN AS SWITCHES FOR DOCUMENTATION PURPOSES.

\* PROVISIONABLE TBOS TO/FROM CONTROLLER OR STATION ALARM 13-16 TO RELAY INTFC

LMW-7064  
5/12/04

Figure 3-46 Alarm and Status Relays/TBOS Interconnect



### 3.22.1 Controller Bus

The Relay Interface communicates with the AE-37() Controller card via the processor bus and the data bus. The processor bus, consisting of three address lines, two control lines, and a clock, is applied to a XCVR. The data bus contains the eight data lines (D0-D7) and is applied to a separate transceiver. Interface with the relay transceivers is provided by the XCVR data bus. When commanded by the AE-37() Controller, the decoder/DEMUX decodes and demultiplexes the address and enables the appropriate relay XCVR via the EN2-9 controls. The controller can then write alarm/status/control information to the relay XCVRs, or read alarm/status/control inputs from the relay XCVRs. Further descriptions of the controller interface signals follow:

- Address lines A0 through A3 – HCMOS inputs. 100K Ohm pull-ups. Used by address decoders to enable output registers and input buffers.
- Buffered bidirectional data lines D0 through D7 – HCMOS input/outputs. 10K Ohm pull-ups. Used to write data to output registers and read present bits or data from input buffers.
- ECLK – 2 MHz bus clock. HCMOS input. 100K Ohm pull-up.
- R/WF Read/Write False. HCMOS input. 100K Ohm pull-up. A logic 1 indicates data is being read from an input buffer or the present bits. A logic 0 indicates data is being written to an output register.
- Relay Intfc CSF – Relay Interface Card Select False. HCMOS input. 100K Ohm pull-up. Chip select for relay interface card. Active low.

### 3.22.2 Control Inputs

Nine buffered control inputs are provided. The inputs are diode protected from voltages outside of the 0 to +5 V range, and have a 10K Ohm resistor for current limiting purposes. In addition, each input has a 100K Ohm pull-up resistor.

- Switch Transmitter (SWITCH TX) – buffered HCMOS input, sends signal to controller module to activate the transmitter that is currently not carrying traffic.
- Switch Receiver (Switch RX) – buffered HCMOS input, sends signal to controller module to activate the receiver that is currently not carrying traffic.
- Switch I/O Interface (SWITCH I/O) – buffered HCMOS input, sends signal to controller module to activate the stand-by I/O interface module.

### 3.22.3 Station Alarm Inputs/TBOS Interface

Each radio shelf can accept/report up to 12 different user-defined station-type alarms, and, if provisioned **Station Alarm 13-16**, the radio can accept an additional four station alarms, for a total of 16. Station alarms 13 through 16 share pins on connector J305 with the four TBOS inputs and outputs. TBOS inputs and outputs are enabled by software when the radio is provisioned **TBOS Display 1-8**. When TBOS is enabled station alarms 13 through 16 are disabled.

The alarm/status input signals are buffered HCMOS inputs, diode protected from voltages outside of the 0 to +5 V range, with 10 kilohm current limiting (series) resistor and 100 kilohm pull-up resistor. A logic 0 indicates an alarm state. A logic 1 (or open) indicates a non-alarm state.

### 3.22.4 Station Alarm Wiring

See Figure 3-47. Use wire wrap adapter PN 695-4171-002 to connect station alarm inputs to the AE-27A Relay Interface module, via connector J305, in each rack. A typical connection scenario is shown. The station/shelf alarm for MCS-11 address A1A (MCS-11 alarm point 1) is connected by software. The station alarms for MCS-11 address A1B and A1C are assigned to MCS-11 Alarm points 2 and 3, respectively.

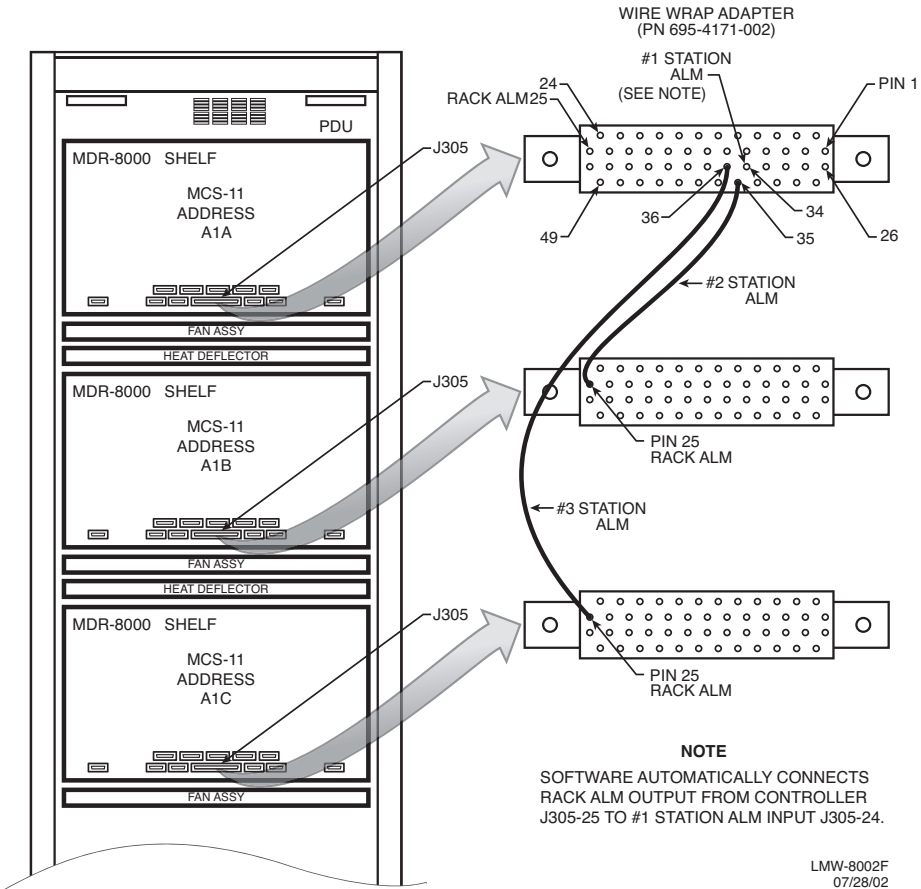

Figure 3-47 Station Alarm Wiring

### 3.22.5 Relay Alarm/Status Outputs

Eight alarm relay outputs and seven status relay outputs provide relay closure to ground (provisioned NO) or open (provisioned NC) when activated. All relays default to open if card power is lost, except the Power Supply alarms, which default to ground. The maximum contact rating for each relay is 0.5 A, 100 Vdc. The alarm/status relay outputs are:

- Alarms:
  - Path Alarm– This summary alarm is activated by the following alarms:
    - A/B Path Distortion
    - A/B AGC Threshold
  - Loss of Input Alarm– This summary alarm is activated by the following alarms:
    - Loss of DS3 input
    - Loss of optical input (OC3/STM-1)
    - Loss of wayside DS1 input
  - A XMT – A-side transmitter failure. This summary alarm is activated by any of the following alarms on the A side:
    - XMT SYNC Alarm
    - RF Power Alarm
    - Common Loss Alarm
    - ATPC Timeout
    - MUX Input Loss Alarm
  - B XMT – B-side transmitter failure. This summary alarm is activated by any of the following alarms on the B side:
    - XMT SYNC Alarm
    - RF Power Alarm
    - Common Loss Alarm
    - ATPC Timeout
    - MUX Input Loss Alarm
  - A RCV – B-side receiver failure. This summary alarm is activated by any of the following alarms on the A side:
    - Channel Alarm
    - RCV Frame Loss
    - Eye Closure
    - RSL Alarm
  - B RCV – B-side receiver failure. This summary alarm is activated by any of the following alarms on the B side:

Channel Alarm

RCV Frame Loss

Eye Closure

RSL Alarm

- PWR Supply Alarm – This summary alarm is activated by any A or B power supply failure.
- Controller Fail – relay is activated if a card select has not been detected in the previous approximately 200 msec.
- Status:
  - A XMTR In Service – A-side transmitter module is on-line.
  - B XMTR In Service – B-side transmitter module is on-line.
  - A RCVR In Service – A-side receiver module is on-line.
  - B RCVR In Service – B-side receiver module is on-line.
  - A I/O In Service – A-side I/O interface module is on-line.
  - B I/O In Service – B-side I/O interface module is on-line.
  - Switch Off Normal – Click on OFF NORM LED on USI Status Alarm screen to view message. Indicates manual control enabled or any of 22 conditions exists. Refer to the Maintenance Section for details.

### 3.22.6 Relay Control Outputs

**Note**

*Control outputs and control status inputs operate together to perform control functions. The control status inputs to the relay interface must be properly wired to the external equipment that is being controlled by the associated control output in order to display the ON or OFF status on the USI control screen. Without the control status inputs, the control function on the USI screen will still turn on equipment/functions, but no status will be indicated and, once turned on, the equipment/function cannot be turned off.*

Six relay control outputs (CTRL 1-6) provide relay closure to ground (provisioned NC) or open (provisioned NO) when activated. These relays default to open if card power is lost. The maximum contact rating for each relay is 0.5 A, 100 Vdc.

Nine buffered status inputs (CTRL STATUS 1-6) from the equipment controlled by the CTRL 1-6 outputs, verifying the controlled function. The inputs are diode protected from voltages outside of the 0 to +5 V range, and have a 10K Ohm resistor for current limiting purposes. In addition, each input has a 100K Ohm pull-up resistor.