



RS420

Portable Stick Reader

USER MANUAL

Version 1.0



Description

The **RS420** reader is a rugged portable hand-held scanner and telemeter for RFID tags specifically designed for livestock applications. The reader fully complies with ISO standards ISO11784 / ISO11785 for FDX-B and HDX technologies.

In addition to its tag reading functions, the reader can store up to 100,000 IDs in different work sessions, each associated with a time/date stamp, in its internal memory and transmit them to a personal computer via an USB interface, a RS232 interface or a Bluetooth® interface.

The device has a large display window which allows you to view the “Main Menu” and configures the reader to your specifications.

Packaging list

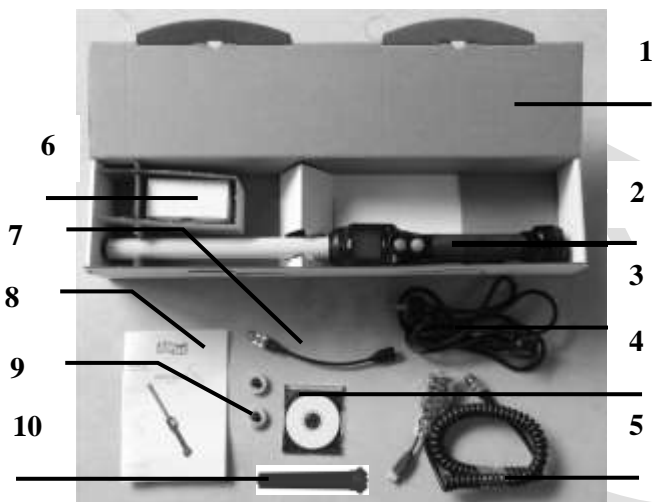

Item	features	Description	Part Number
1	Cardboard	Use to transport the reader	
2	Reader	-	
3	IEC cable	Supply cable to power the external adapter	
4	CD-ROM	Support for user manual and reader datasheets	
5	Data-Power Cable	Conveys external power to reader and serial data to and from reader.	
6	External Power Adapter	Power the reader and charge the battery.	
7	USB flash drive adapter	Allows the user to connect an USB stick to upload or to download data to or from reader.	
8	User Manual	-	
9	Ear Tags	2 ear tags to demonstrate and test FDX and HDX reading capabilities.	
10	Rechargeable Li-Ion battery	Supplies the reader. Adds expected battery life	

Figure 1 - Reader features and user interface.

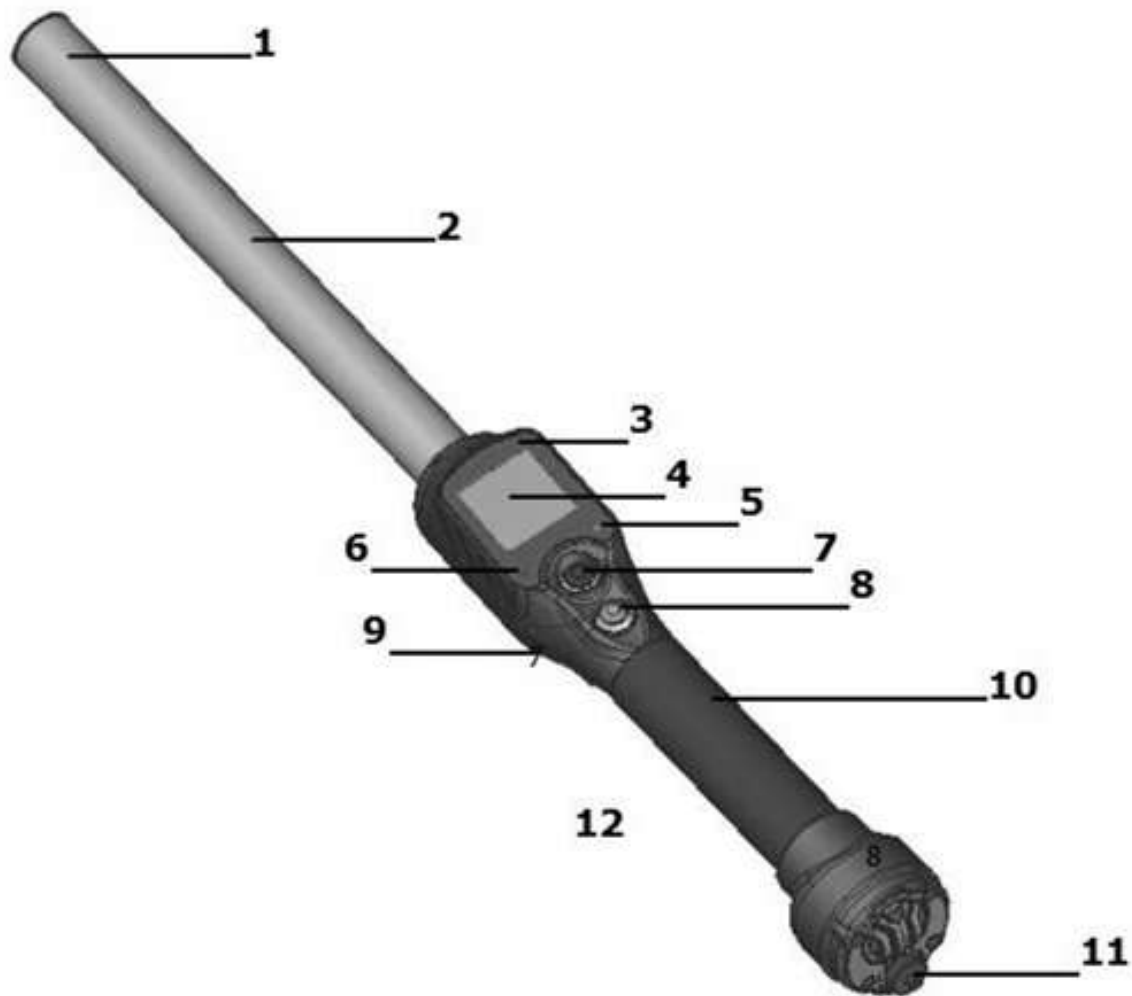

Table 1 – Reader features and description of use

Item	Feature	Description of use
1	Antenna	Emits activation signal and receives transponder signal.
2	Fiberglass Tube Enclosure	Rugged and watertight enclosure.
3	Audible beeper	Beeps once on first transponder reading and 2 short beeps for repeat.
4	Large graphical readout with backlight	Displays information about current reader status.
5	Green indicator	Illuminates whenever a transponder data has been stored.
6	Red indicator	Illuminates whenever antenna is emitting activation signal.
7	black MENU button	Navigates in the reader menu to manage or to configure it.
8	green READ button	Applies power and causes activation signal to be emitted for reading transponder
9	Vibrator	Vibrates once on first transponder reading and short vibrates for repeat.
10	Handle grip	Rubber anti-slip gripping surface
11	Cable connector	Electrical interface for attaching Data/Power cable or USB stick adapter.
12	Bluetooth®	Wireless interface to communicate data to and from reader (not pictured)

Operation

Getting Started

It is necessary first to fully charge the Battery Pack as described below and to have a few electronic identification ear tags or implants available for testing. **It is very important to carry out the three steps described in this section before using the reader (see “Battery handling instructions” section for more information)**

Step 1: Installing the battery pack in the device.



1

Insert the battery in the reader. The pack is keyed for proper installation.



2

The stationary key should be up towards the display. The battery pack will “snap” into place when it is properly inserted. **DO NOT FORCE** the battery into the reader. If the battery does not insert smoothly, verify it is properly orientated.

Step 2: Charging the battery pack.



1

Unscrew the protective cap which guards against foreign material contamination.
Insert the data-power cable by engaging the connector and rotating the lock-ring.

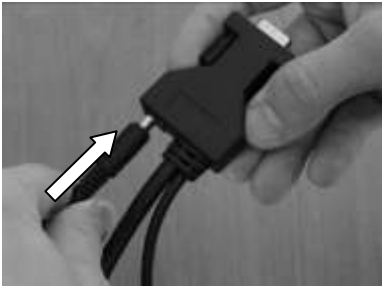

2 Plug the power cord into the cable socket located at the end of the data-power cable.



3 Plug the adapter into a power outlet. The icon of the battery level indicates that the battery pack is in charge (the level bars flash inside the icon) and gives the battery charge level.

The icon of the battery level will be  when charging has finished. Charging takes approx. 3 hours.

4 Remove the power cord.
Unplug the adapter from the power outlet, and remove the data-power cable inserted in the reader.

Power on instructions

Press the **green** button on the reader handle to power on the reader. The main screen will appear on the display:

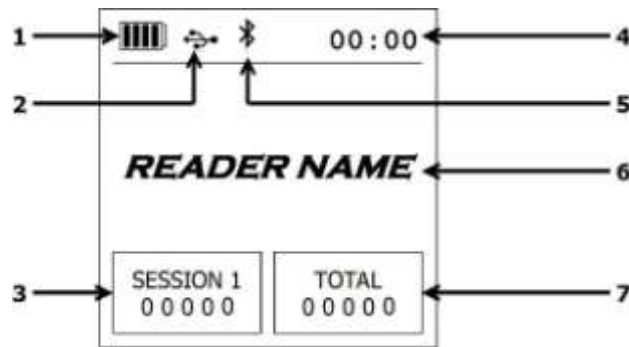

Item	Feature	Description of use
1	Battery level	The battery level shows the fully charged level as well as the charge level during the charge mode.
2	USB connection	Appears when the reader is connected to a computer via USB port. NOTE: The reading mode is disabled if there is no battery and no external power supply. Therefore it is not possible to read a transponder although the other functions are fully active.
3	Current number of ID codes	Number of read and saved ID codes in the current session.
4	Clock	Clock time in 24 hour mode.
5	Bluetooth connection	Check the Bluetooth® status and connection (see section "Bluetooth® management" for more details).
6	Reader name	Display the reader name. It appears only upon power on and until a tag is read.
7	Number of ID codes	Total number of read and saved ID codes in all recorded sessions.



Note 1 - Once activated, the reader will remain activated for 5 minutes by default, if it is powered only by its battery pack.

Read Range Performance

Figure 2 illustrates the reading zone of the reader, within which tags can be successfully detected and read. Optimum read distance occurs depending upon the orientation of the tag. Tags and implant read best when positioned as shown below.

Figure 2 - Optimum Read Distance Tag Orientation

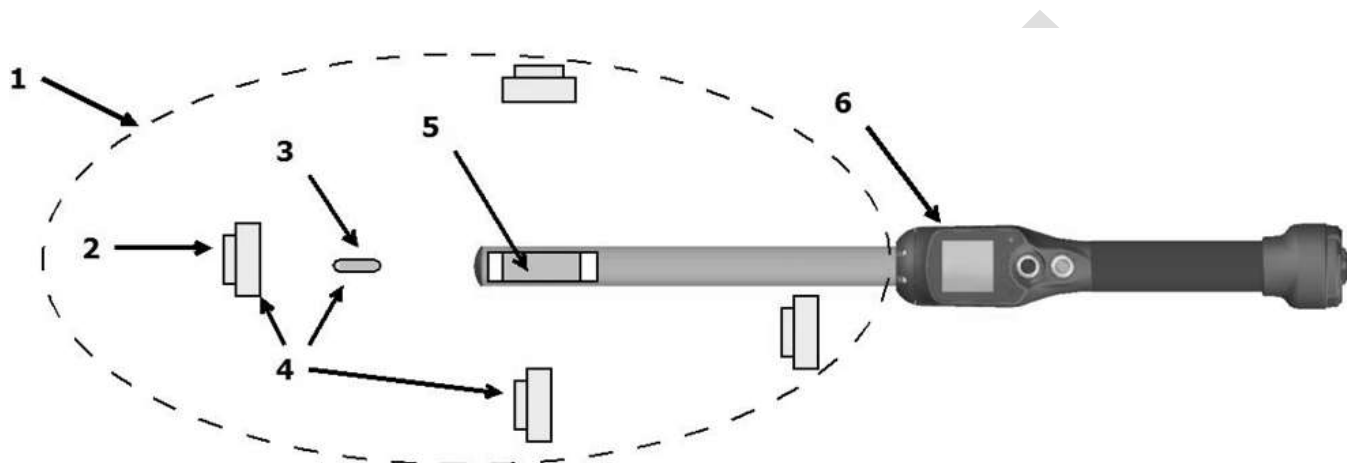

Item	Legend	Comments
1	Reading zone	Area in which the ear tags and the implants can be read.
2	RFID Ear tag	-
3	RFID Implant	-
4	Best orientation	Best orientation of the ear tags regarding the reader antenna
5	Antenna	-
6	Reader	-

Typical read distances will vary when reading different types of ear tags, in the optimum tag orientation at the end of the reader (as shown in Figure 2), the reader will read up to 42cm depending tag type and orientation.

Power off instructions

The reader can be powered off by simultaneously depressing BOTH buttons for approximately 3 seconds

Read a RFID transponder

Scanning animals

Place the device near the animal identification tag to be read, then press the green button in order to activate the reading mode. The screen backlight switches on and the red light is flashing.

During the reading mode, move the reader along the animal to scan the transponder ID. The reading mode remains activated during a programmed duration. If the user is always pressing the green button, the reading mode remains activated. If the device is programmed in continuous reading mode, the reading mode remains indefinitely activated up to the user stop it by pressing again the green button.

The following picture shows the result of a successful reading session:

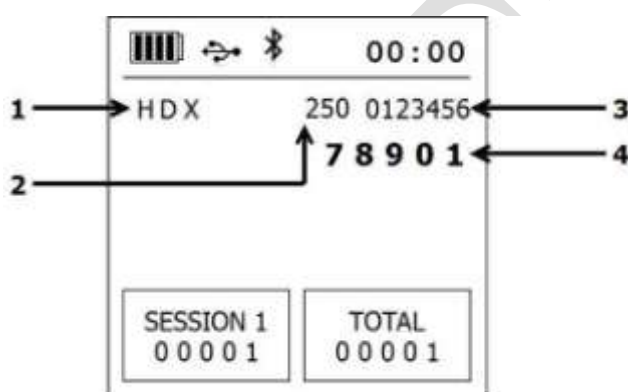

Item	Feature	Description of use
1	Transponder type	ISO standard 11784/5 has approved 2 technologies for animal identification: FDX-B and HDX. When the reader displays the word "IND" as transponder type, it means that its transponder is not coded for animals.
2	Country code / Manufacturer code	The country code is according the ISO 3166 and ISO 11784/5 in numeric or in alpha coding. Manufacturer code is according to ICAR assignment.
3	First digits of ID code	First digits of the identify code is according the ISO 11784/5.
4	Last digits of ID code	Last digits of the identify code is according the ISO 11784/5. The user can select the number of last bold digits (between 3 and 8 digits).

When a new EID transponder is successfully read, the green light flashes and the reader stores the ID code in its internal memory after its first reading (and if the option "duplicate search" is activated) with the current date and time (if the option is activated).

The number of read ID codes in the current session is increased.

The buzzer and the vibrator will sound and/or vibrate with every scan.



Note 2 –The ‘Date and Time Stamp’, and the sound/vibration features are options that can be turned on or off according to your specific applications.

Each time a tag is scanned, the identification code is transmitted automatically via the USB cable, the RS232 cable or Bluetooth®.

Tips for efficient reading

Tag reader efficiency is often linked with reading distance. The device's read distance performance is affected by the following factors:

1. Transponder orientation: to obtain maximum reading distance, the axes of the transponder and reader antenna coils must be optimally orientated as shown in Figure 2.
2. Transponder quality: Each transponder manufacturer uses their own unique manufacturing process. Consequently, it is normal to find that many common transponders from different manufacturers have different read range performance levels.
3. Animal movement: If the animal moves too quickly, the transponder may not be located in the read zone long enough for the ID code information to be obtained.
4. Transponder type: HDX and FDX-B transponders generally have similar reading distances, but tag manufacturers and environmental factors such as RF interferences may affect overall tag performances.
5. Nearby metal objects: Metal objects located near a transponder or reader may attenuate and distort the magnetic fields generated in RFID systems and therefore, reduce reading distance. An example, an ear tag against a squeeze chute significantly reduces the read distance.
6. Electrical noise interference: The operating principle of RFID transponders and readers is based on electromagnetic signals. Other electromagnetic phenomena, such as radiated electrical noise from other RFID tag readers, or computer screens may interfere with RFID signal transmission and reception, therefore, reduce the read distance.
7. Transponder/reader interference: Several transponders in the reception range of the reader, or other readers that emit excitation energy close by may adversely affect reader performance or even prevent the reader from operating.
8. Discharged battery pack: As the battery pack discharges, the power available to activate the field becomes weaker, which in turn reduces the read range field.

Wireless synchronization

A reader which is in the vicinity of a second reader is very likely to transmit its activation signal during the listening pause of the second reader and vice versa. The result is that neither reader will be able to receive the HDX telegram.

Wireless synchronization can be used to control the coordination of readers. The proviso is that the electrical noise in the environment is low and the RFI noise is constant, for the type of readers in use.

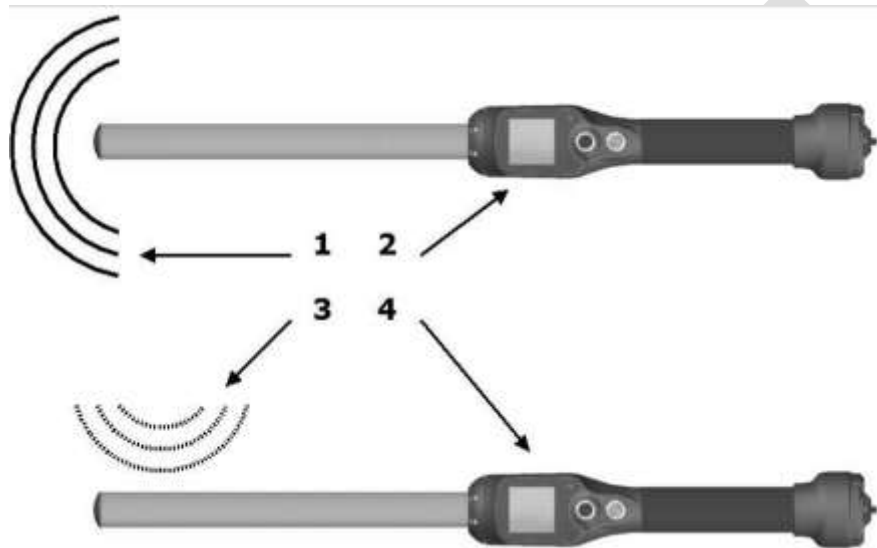

Item	Legend	Comments
1	Activation signal of reader 1	-
2	Reader 1	reader 1 in transmitting mode.
3	Activation signal of reader 2	-
4	Reader 2	reader 2 in listening mode.

“A mobile transceiver by nature cannot directly be connected to other transceivers. To prevent a mobile transceiver interfering with the interrogation protocol of other transceivers, it must be able to detect the presence of additional active transceivers through the reception of activation signals.

If no activation signal is detected within 30 ms, the transceiver is out of reach of other active transceivers and its activation signal will not interfere with other interrogation processes. The transceiver can therefore safely use the protocols defined in clause 6 of this International Standard. If the mobile transceiver detects an activation signal it must wait for the rising edge of the next activation signal and activate during a fixed period of 50ms.” (cf. ISO1185 – Annex C chapter 3)



Note 3 – Activate the wireless synchronization feature only with readers which complied with the ISO11785 timings.

Managing the menu

Using the menu

With the reader powered on, press the black button for over 3 seconds.

The device lists on the screen, the following features:

Item	Sub-Menu	Definition
1	Back	Return to the main screen
2	Session	Enter into the session management sub-menu.
3	Bluetooth	Enter into the Bluetooth management sub-menu.
4	Settings	Enter into the device settings sub-menu.
5	Reader information	Gives information about the reader.



Note 4 – To enter into a sub-menu, move the horizontal lines by pressing the green button and press the **black** button to select it.



Note 5 - The reader automatically closes the menu if no action occurs for 8 seconds.

Session management

Once, the sub-menu “session” is selected, the device lists on the screen, the following options:

Item	Sub-Menu	Definition
1	Back	Return to the main screen
2	New session	Create a new work session after validation by the user. This new session becomes the current one and the previous one is closed.
3	Open existing	List all stored sessions and indicates the number of saved ID codes per each session.
4	Compare session	Enter into the compare sub-menu.
5	Clear session	all Erase all stored sessions.



Note 6 – Each ID Code is stored internally in the reader’s memory until the user erases the stored ID codes after downloading them to a PC or other recording device, such as a USB stick. Up to 100,000 ID codes (10,000 ID codes per sessions) can be stored and retrieved later at the user’s convenience.



Note 7 – If enabled, the reader provides a time and date stamp for each ID number stored.

The user can enable the date and time through a communication interface (USB, Serial or Bluetooth® port) and the software program.

Once, the sub-menu “compare session” is selected, the device lists the following options:

Item	Sub-Menu	Definition
1	Back	Return to the main screen
2	Select compare	List all sessions saved inside the reader and select the comparison session used to compare the read ID codes.
3	Disable compare	Disable the comparison.
4	Alerts	Enter into the alert sub-menu.



Note 8 – When a tag is read and compared successfully to an ID code stored in a selected comparison session, supplementary information stored in the comparison session, is displayed on the reader’s screen (ex: visual id code, supplementary data...)

Once, the compare session sub-menu is selected, the device lists the following options:

Item	Sub-Menu	Definition
1	Back	Return to the main screen
2	Disabled	Disable the alert management.
3	On animal found	Produce an alert signal when the read ID code is found in the comparison session.
4	Sort animals	Produce an alert signal when the read ID code is NOT found in the comparison session.
5	From secondary data	Produce an alert message is associated to the read ID code in the comparison list.

Bluetooth® management

Once, the sub-menu “Bluetooth®” is selected, the device lists the following options:

Item	Sub-Menu	Definition
1	Back	Return to the main screen
2	On/Off	Enable or Disable the Bluetooth® feature.
3	Search device	Scan and list all Bluetooth® devices in the reader proximity.
4	Cancel Pairing	Cancel the current pairing and put the reader in SLAVE mode.
5	About	Provide information about the Bluetooth® features (see below).



About Bluetooth	
1 →	Name: Reader Name
2 →	Addr: 00:04:3E:21:93:E6
3 →	Pairing: 00:A0:96:29:B5:7E
4 →	Security: On
5 →	Apple device: No
6 →	PIN: 1234
7 →	Version: 120215B IDPS

Item	Feature	Description of use
1	Name	Name of the reader.
2	Addr	Address of the Bluetooth® module.
3	Pairing	Device address with which the reader is paired (reader is in master mode) or SLAVE when the reader is in slave mode.
4	Security	On/Off – the Bluetooth® connection is secure or not.
5	Apple device	Yes/No – the Apple’s compatibility is enabled or disabled.
6	PIN	Pin code
7	Version	Version of the Bluetooth® stack.

Note 9 – Understanding the Bluetooth® icon:

When the Bluetooth® module is enabled, an icon  is displayed.

If the icon  doesn’t blink, that means the device is in slave mode and NOT paired with a device.

If the icon flashes between  and , the device is in master mode and it is trying to established a connection with a slave device.

If the icon  is displayed, once a connection has been established (in slave or in master mode).

Note 10 – 1 beep is emitted and 1 message is displayed when the Bluetooth® connection is established and 3 beeps are emitted when the connection is removed.

Settings

Once, the sub-menu “settings” is selected, the device lists the following options:

Item	Sub-Menu	Definition
1	Back	Return to the main screen
2	Profiles	Allow to store, to recall or to erase profiles
3	Quick action	Attribute a second feature to the black button.
4	Read time	Manage the time of reading.
5	Vibrator	Manage the vibrator.
6	Buzzer	Manage the audible beeper.
7	RFID Power Mode	Manage the power consumption of the device.
8	Protocol	Select the protocol used by the communication interfaces.
9	Language	Select the language used by the device.
10	Load defaults	Erase the current settings and load the default settings.

Once, the sub-menu “profile” is selected, the device lists the following options:

Item	Sub-Menu	Definition
1	Back	Return to the main screen
2	Store profile	Store a profile. When the profile is saved, a message “Profile X saved!” is displayed. If there is no free profile, the message “no free profile” is displayed.
3	Recall profile	Recall a saved profile
4	Erase a profile	Erase a saved profile. A confirmation message is displayed.
5	Erase all profiles	Erase all profiles. A confirmation message is displayed.



Note 11 – A profile corresponds to the current settings of the reader. The user can save up to 4 profiles.

Once, the sub-menu “quick action” is selected, the device lists the following options:

Item	Sub-Menu	Definition
1	Back	Return to the main screen
2	Disabled	No feature attributed to the black button
3	Enter menu	Fast access to the menu.
4	New session	Fast creation of a new session.
5	Re-send last tag	Last read tag is re-sent on the communication interfaces.



Note 12 – a quick action is a second feature attributed to the black button. The reader performs the selected action after a short keystroke of the black button.



Note 13 – If the user holds the black button for over 3 seconds, the device displays the menu and the quick action is not performed.



Note 14 – the symbol “>” is in front of the current selected option.

Once, the sub-menu “read time” is selected, the device lists the following options:

Item	Sub-Menu	Definition
1	Back	Return to the main screen
2	3 seconds	The reader will scan for tags for 3 seconds.
3	5 seconds	The reader will scan for tags for 5 seconds.
4	10 seconds	The reader will scan for tags for 10 seconds.
5	Continuous	The reader will scan for tags continuously.

Once, the sub-menu “vibrator” is selected, the device lists the following options:

Item	Sub-Menu	Definition
1	Back	Return to the main screen
2	Disabled	Disable the vibrator
3	Enabled	Enable the vibrator

Note 15



- A short vibration indicates that the reader has previously read the tag during the current session.
- A vibration of medium-duration means that the reader has read a new tag which has NOT been previously read during the current session.
- A long vibration means that there is an alert regarding the tag which has been read.

Once, the sub-menu “buzzer” is selected, the device lists the following options:

Item	Sub-Menu	Definition
1	Back	Return to the main screen
2	Disabled	Disable the audible beeper.
3	Enabled	Enable the audible beeper.

Note 16



- A short beep indicates that the reader has switched on or that the Bluetooth® connection is established.
- Two short beeps mean that the reader has previously read the tag during the current session.
- Three short beeps mean that the Bluetooth® connection is removed.
- A beep of medium-duration means that the reader has read a new tag which has NOT been previously read during the current session
- A long beep means that there is an alert regarding the tag which has been read.

Once, the sub-menu “RFID power mode” is selected, the device lists the following options:

Item	Sub-Menu	Definition
1	Back	Return to the main screen
2	Save power	Puts the device in low power consumption with shorter reading distances.
3	Full power	Puts the device in high power consumption



Note 17 – When the reader is in low consumption, the reading distances are reduced.

Once, the sub-menu “protocol” is selected, the device lists the following options:

Item	Sub-Menu	Definition
1	Back	Return to the main screen
2	Standard protocol	Select the standard protocol defined for this reader (see specifications Protocol_Document_V1.0).
3	Allflex RS320 / RS34	Select the protocol used by ALLFLEX’S readers RS320 and RS340.



Note 18 – All commands of ALLFLEX’S reader are implemented but all functionalities are not implemented (see specifications Protocol_Document_V1.0).

Once, the sub-menu “language” is selected, the device lists the following options:

Item	Sub-Menu	Definition
1	Back	Return to the main screen
2	English	Select the English language
3	French	Select the French language
4	Spanish ¹	Select the Spanish language

About the reader

Once, the sub-menu “Reader information” is selected, the device displays the following information:

Reader information	
1 →	FW: 0.98.17b - Apr 26 2012
2 →	HW: A3
3 →	Memory used: 2%
4 →	Files used: 4/400
5 →	Batt: 47%

Item	Feature	Description of use
1	FW	Indicates the firmware version of the reader
2	HW	Indicates the hardware version of the reader
3	Memory used	Indicates the percentage of the memory used.
4	Files used	Indicates the number of files saved in the reader.
5	Batt	Indicates the battery charge level in percentage.

¹ Not implemented in the reader.

Connect the reader to a PC

This section is meant to describe how to connect the reader to hand held computer (PDA) or to a personal computer (PC). The device can be connected to a PC in 3 ways: a wired USB connection, a wired RS-232 connection or by wireless Bluetooth® connection.

Using USB interface

The USB port allows the device to send and receive data via an USB connection. To make USB operate, connect the reader to a PC or a PDA with the data-power cable.



- 1 Remove the protective cap which covers the reader's cable connector, and guards the reader against foreign material contamination.
Install the data-power cable by engaging the connector and rotating the lock-ring.



- 2 Plug the USB extension into a USB port on your computer.



Note 19 – Once the USB cable is connected, the reader is automatically powered on and it will remain activated until the cable is disconnected. The reader will be able to read a tag if a sufficient charged battery is inserted. With a depleted battery, the reader will not be able to read a tag, but will remain on and can only communicate with computer.

When connecting to a PDA or a PC, you may need to install specific drives supplied by its manufacturer. When connecting to a Windows PC, the operating systems start the Device Manager (more details provided by the manufacturer on the CDROM).

Using serial interface

The serial port allows the device to send and receive data via an RS-232 connection.

To make RS-232 operate, you need to connect the reader with a PC or a PDA with the data-power cable.

The RS232 serial interface comprises a 3-wire arrangement with a DB9F connector, and consists of transmit (TxD/pin 2), receive (RxD/pin 3), and ground (GND/pin 5). This interface is factory configured with the default settings of 9600 bits/second, no parity, 8 bits/1 word, and 1 stop bit (“9600N81”). These parameters can be changed from PC software.

Serial output data appears on the device’s TxD/pin 2 connection in ASCII format.



Note 20 - The RS232 interface is wired as a DCE (data communications equipment) type that connects directly to the serial port of a PC or any other device that is designated as a DTE (data terminal equipment) type. When the device is connected to other equipment that is wired as DCE (such as a PDA), a “**null modem**” adapter is required in order to properly cross-wire transmit and receive signals so that communications can occur.





Note 21 - The reader’s serial data connection can be extended using a standard DB9M to DB9F extension cable. Extensions longer than 20 meters (~65 feet) are not recommended for data. Extensions longer than 2 meters (~6 feet) are not recommended for data and power.

Using Bluetooth® interface

Bluetooth® works on a premise that one end of the communication will be a MASTER and the other a SLAVE. The MASTER initiates communications and looks for a SLAVE device to connect to. When the reader is in SLAVE mode it can be seen by other devices such as a PC or PDA. PDAs and computers usually behave as MASTERS with the reader configured as a SLAVE device.

When the reader is configured as a MASTER it cannot be seen by other devices other than the device it is paired to. Readers are typically used in a MASTER mode configuration when it only needs to be paired with a single device such as a scale head, PDA or Bluetooth printer. The reader is equipped with a Class 1² Bluetooth® module and is compliant with the Bluetooth® Serial Port Profile (SPP) and the Apple’s iPod® Accessory Protocol (iAP). The connection can be in slave mode or in master mode.

When the module is enabled, the icon  is displayed and once the communication is established between the reader and another device, the icon is replaced by the icon .

² Operating distance of communication is around 100 m (330 ft).

If you are using a PDA, it will require software (Not supplied by the manufacturer). Your software supplier will explain how to connect the PDA.



Note 22 - We advise that to achieve successful Bluetooth® connection with your reader, simply follow the implementation methods listed (see the following).



Note 23 - If these implementation methods are not followed, the connection may become inconsistent, thus causing other reader related errors.

Bluetooth® – Known Successful Methods

There are 2 scenarios to correctly implement the Bluetooth® connection. These are:

1. Reader to a Bluetooth® adapter connected to a PC, or to a Bluetooth® enabled PC or PDA.
2. Reader to a Bluetooth® adapter connected to a scale head, or to a Bluetooth® enabled device, such as scale head or printer.

These options are discussed in further details below.

Reader to a Bluetooth® adapter connected to a PC, or to a Bluetooth® enabled PC or PDA

This scenario requires that a process called « Pairing » be undertaken. On the reader, go to the menu “Bluetooth”, and then select the sub-menu “Cancel Pairing” to remove the previous pairing and allow the reader to return to SLAVE mode.

Start your PC Bluetooth® Manager program or PDA Bluetooth® services,

Depending on which Bluetooth device your PC is using the Bluetooth Manager may vary in how it pairs a device. As a general rule you the program should have the option to “Add a Device” or “Discover a Device”.



With the reader turned on, select one of these options. The Bluetooth® program should open a window within one minute showing all Bluetooth enabled devices in the area. Click on the reader you want to connect to and follow the steps provided by the program.



The program may ask you to provide a “Pass Key” for the device. As noted in the following example, select the option “Let me choose my own passkey” The default passkey for the reader is: **1234**

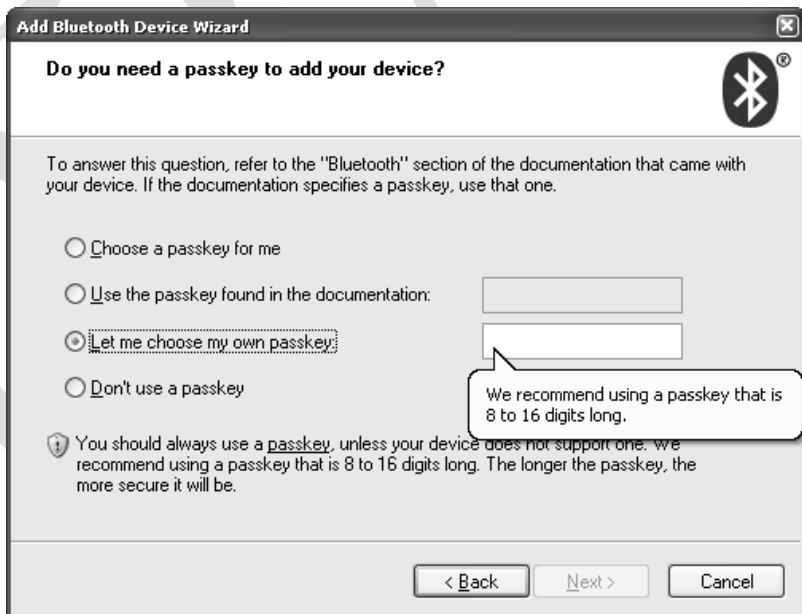

The program will assign 2 communication ports for the reader. Most applications will use the outgoing port. Make note of this port number for use when connecting to a software program

If this fails use the following links, search the reader in the peripheral list and connect it. You have to add an outgoing port that makes a connection to the device. Follow the steps described in the links below.

For Windows XP: <http://support.microsoft.com/kb/883259/en-us>

For Windows 7: <http://windows.microsoft.com/en-US/windows7/Connect-to-Bluetooth-and-other-wireless-or-network-devices>



Note 24 - Sometimes, a PIN code is required to connect the reader to the PC, PDA... In such case, the PIN code to use is **1234**.

Reader to a Bluetooth® adapter connected to a scale head, or to a Bluetooth® enabled device, such as scale head or printer.

This scenario requires that the reader lists the Bluetooth® peripherals. Go to the menu “Bluetooth”, then the sub-menu “Search device” which launches the Bluetooth® scanning.

The device you want to connect to will be displayed on the reader. Use the green button to scroll to the desired device. Select the device by depressing the black button on the reader. The reader will now connect in “slave” mode.

To connect the reader in ‘Master’ mode the reader will need to be configured using the Tag Manager program. In the “Reader setup” section of the Tag Manager Program, the user can enter the 12 character address of the device they want to connect to. Once this is done the reader will be in Master mode when it connects to that device.



Note 25 - Sometimes, the security features and checking have to be disabled on the reader to established the connection with a printer. So use PC software provided with the reader, to configure the reader’s Bluetooth® security (refer to PC software documentation).

Connect the reader to an USB flash drive³

The reader can be equipped with an USB stick. To connect this USB flash drive, the reader is provided with an adapter cable which allows the user to connect an USB flash drive to the reader.

With this stick, the user can import and/or export sessions. The sessions can be some working sessions stored in the reader or some comparison sessions which contain details and information about each animal ID code.

³ Not implemented in the reader.

Power Management

Reader Power Sources

The reader contains a 7.4VDC – 2600mAh Li-Ion rechargeable battery pack, which serves as its primary power source. Add expected hours/scans of a fully charged battery.



Alternately, the reader can be powered by the following methods:

1. From its AC Adapter. Once the external AC adapter is connected, the reader is powered-up, it will remain on until the AC adapter is disconnected and the Battery Pack is charged. The reader can be powered regardless of the charge state of the Battery Pack. The AC Adapter can be used as a power source even if the Battery Pack has been removed from the device. If the AC Adapter has been connected, the user may proceed with configuration and performance testing while the Battery Pack is charging. This configuration could affect reading performances.
2. From its USB cable but it cannot read transponders without a charged battery. During the USB connection, the reader charges the battery pack.
3. From its DC power supply cable with alligator clips⁴: You can connect your reader to any DC power supply (between minimum 12V DC and maximum 28V DC) such as a car, truck, tractor, or battery. The reader is connected through the socket located on the back of the reader data-power cable as shown in step 2 (see chapter “Getting Started”).

Step 1: Connect to a battery



- 1 Connect the **black** alligator clip to the negative terminal (-). Connect the **red** alligator clip to the positive terminal (+).

⁴ Not proposed for sale in Europe

Step 2: Connect to the reader



- 1 Remove the protective cap which covers the reader's cable connector, and which guards the reader against foreign material contamination. Install the data-power cable by engaging the connector and rotating the lock-ring.

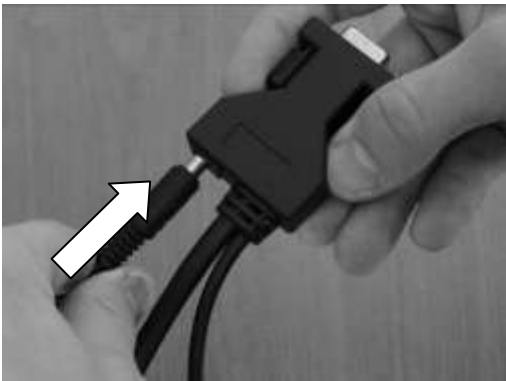





- 2 Then connect the other end of the battery cable into the power socket located at the end of the reader's data-power cable

Step 3: Checking the reader



- 1 Once you are connected to a power source, the reader display's backlight will turn on. Press the green button momentarily and notice the flashing red light. This indicates that the reader is receiving power.

At the top of the screen, the icon of the battery level shows the discharge level as well as the charge level during the charge mode.

Display	Summary
	Good.
	Quite good.
	Slightly depleted, but sufficient
	Depleted. Recharge the battery.
"LOW BATTERY"	Depleted. Recharge the battery.

Reader power instructions



Note 26 - The reader is designed to operate only with the Battery Pack provided. The reader will not operate with individual battery cells of either disposable or rechargeable variety.



CAUTION

RISK OF EXPLOSION IF BATTERY IS REPLACED BY AN INCORRECT TYPE. DISPOSE OF USED BATTERIES ACCORDING TO THE INSTRUCTIONS.



Note 27 - Do not use this reader near water when connected to the AC/DC adapter.



Note 28 - Do not install near any heat sources such as radiators, heat registers, stoves, or other apparatus that produce heat.



Note 29 - Do not charge the battery pack from AC main sources during electrical storms or when unused for long periods of time.



Note 30 - The reader is protected for reverse polarity connections.

Battery handling instructions

Please read and follow the handling instructions for the battery before use. Improper use of the battery may cause heat, fire, rupture, and damage or capacity deterioration of the battery.



Caution

1. Do not use or leave the battery in high heat environments (for example, at strong direct sunlight or in a vehicle in extremely hot weather). Otherwise, it can overheat ignite or battery performances will be degraded, thus shortening its service life.
2. Do not use it in a location where static electricity is rich, otherwise, the safety devices may be damaged, causing a harmful situation.
3. In case the electrolyte gets into the eyes due to the leakage of battery, do not rub the eyes! Rinse the eyes with clean running water, and seek medical attention immediately. Otherwise, it may injure eyes or cause a loss of sight.
4. If the battery gives off an odour, generates heat, becomes discoloured or deformed, or in any way appear abnormal during use, recharging or storage, immediately remove it from the device and place it in a contained vessel such as a metal box.
5. Power or charge failure may occur due to the poor connection between the battery and the reader if the terminals are dirty or corroded.
6. In case the battery terminals are corroded, clean the terminals with a dry cloth before use.
7. Be aware that discarded batteries may cause fire. Tape the battery terminals to insulate them before disposal.



Warning

1. Do not immerse the battery in water.
2. Keep the battery in a cool dry environment during storage periods.
3. Do not use or leave the battery near a heat source such as fire or heater.
4. When recharging, use only the battery charger from manufacturer.
5. The battery charge can be realized at a temperature between 0° and +45°C.
6. Do not let the battery terminals (+ and -) contact any metal (like ammunition, coins, metal necklace or hairpin). When carried or stored together this may cause short-circuit, or severe bodily damage.
7. Do not strike or puncture the battery with other objects, or use in any way other than its intended use.
8. Do not disassemble or alter the battery.



Notice

1. The battery should only be charged and discharged using the proper charger supplied with the reader.
2. Do not replace the battery with other manufacturer's batteries, or different types and /or models of batteries such as dry batteries, nickel-metal hydride batteries, or nickel-cadmium batteries, or a combination of old and new lithium batteries together.
3. Do not leave the battery in a charger or equipment if it generates an odor and/or heat, changes color and/or shape, leaks electrolyte, or cause any other abnormality.
4. Do not discharge the battery continuously when it is not charged.
5. It is necessary first to fully charge the Battery Pack as described in the section “Getting Started” before using the reader

Accessories for the reader

Battery pack fast charger

The fast charger is used to charge up to 2 Battery Packs simultaneously in 3 hours. A light indicates the status of each battery charging.

Green light	Red light	Charger status
Off	Off	Not Charging – Standby or Shutdown
Off	On	Bad-Battery fault
On	Off	Normal Charging
On	On	Temperature fault



Note 31 – the lights switch off when the batteries are fully charged.

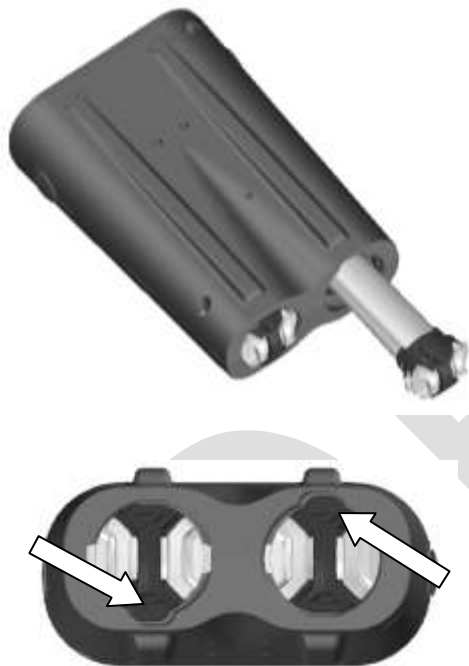

The battery charger can be placed horizontally or vertically on a table.

Make sure the battery orientation is correct before insertion into the charger.

Plastic Carry Case

Durable Plastic Carry Case is available as an optional extra or is included in the “Premium Kit” Package.



Specifications

General	
Norms:	ISO 11784 and full ISO 11785 for FDX-B and HDX tags IP67
User interface:	Graphical display 128x128 dots 2 keys Buzzer and Vibrator Serial port, USB port and Bluetooth® module
USB interface:	CDC class (Serial emulation) and HID class.
Bluetooth® interface:	Class 1 (up to 100m) Serial Port Profile (SPP) and iPod Accessory Protocol (iAP)
Serial interface	RS-232 (9600N81 by default)
Memory:	>100,000 animal IDs (10,000 animal IDs per session)
Battery:	7.4VDC – 2600mAh Li-Ion rechargeable.
Typical operating time:	X hours @ 20°C
Date/Time autonomy:	3 months without reader usage @ 20°C
Battery charge duration:	3 hours

Mechanical and physical	
Dimensions:	
Weight:	
Material	ABS-PC and fiberglass tube
Operating temperature	-20°C to +55°C (+14°F to +104°F)
Storage temperature	-30°C to +70°C (-22°F to +158°F)
Humidity:	80%

Reading	
Distance for ear tags (cattle):	Up to 42 cm (16.5 in) depending on tag type and orientation.
Distance for implants:	Up to 20 cm (8 in) for 12-mm FDX-B ear tags.
Distance for ear tags (sheep):	Up to 30 cm (12 in) depending on tag type and orientation.

Reader physical integrity

The device has been built from rugged and durable materials to withstand use in harsh environments for long periods of time. However, the reader contains electronic components that can be damaged if they are deliberately exposed to extreme abuse. This damage can adversely affect, or stop the reader's operation. The user must avoid deliberately striking other surfaces and objects with the device. Damage that results from such handling is not covered by the warranty described below.

Limited Product Warranty

Manufacturer guarantees this product against all defects due to faulty materials or workmanship for a period of one year following the date of purchase. The warranty does not apply to any damage resulting from an accident, misuse, modification or an application other than that described in this manual and for which the device was designed.

If the product develops a malfunction during the warranty period, manufacturer will repair or replace it free of charge. The cost of shipment is at the customer's expense, whereas return shipment is paid by manufacturer.

Refer all servicing to qualified service personnel. Servicing is required when the reader has been damaged in any way, such as power-supply cord or plug is damaged, liquid has been spilled or objects have fallen into the apparatus, the apparatus has been exposed to rain or moisture, does not operate normally, or has been dropped.

Regulatory information

USA-Federal Communications Commission (FCC)

This device complies with part 15 of FCC rules. Operation is subject to the following two conditions: (1) This device may not cause interference, and (2) this device must accept any interference, including interference that may cause undesired operation of the device.

This equipment has been tested and found to comply with the limits for a Class B digital device, pursuant to Part 15 of FCC Rules. These limits are designed to provide reasonable protection against harmful interference in a residential installation.

This equipment generates, uses, and can radiate radio frequency energy. If not installed and used in accordance with the instructions, it may cause harmful interference to radio communications. However, there is no guarantee that interference will not occur in a particular installation.

If this equipment does cause harmful interference to radio or television reception, which can be determined by tuning the equipment off and on, the user is encouraged to try and correct the interference by one or more of the following measures:

Reorient or relocate the receiving antenna.

Increase the distance between the equipment and the receiver.

Connect the equipment to outlet on a circuit different from that to which the receiver is connected.

Consult the dealer or an experienced radio/TV technician for help.

The user must be at 20 cm of the reader antennas.

Notice to Consumers:

Any changes or modifications not expressly approved by the party responsible for compliance could void the user's authority to operate the equipment.

Canada – Industry Canada (IC)

This device complies with RSS 210 of Industry Canada. Operation is subject to the following two conditions: (1) This device may not cause interference, and (2) this device must accept any interference, including interference that may cause undesired operation of this device.”

L ' utilisation de ce dispositif est autorisée seulement aux conditions suivantes : (1) Il ne doit pas produire d'interférence et (2) l'utilisateur du dispositif doit être prêt à accepter toute interférence radioélectrique reçu, même si celle-ci est susceptible de compromettre le fonctionnement du dispositif.

Avis aux consommateurs:

Toutes modifications non expressément approuvées par la partie responsable de la conformité peuvent annuler le droit de l'utilisateur à utiliser cet équipement.

L'utilisateur doit se tenir à 20 cm des antennes du lecteur.

Regulatory Compliance

ISO 11784 & 11785

This device complies with the standards set forward by the International Standardization Organization. Specifically with standards:

11784: Radio frequency identification of animals -- Code Structure

11785: Radio frequency identification of animals -- Technical Concept.

FCC NQY-30002

IC 4246A-30002

CE Marking



Ailflex **DECLARATION OF CONFORMITY** 

According to the
R&TTE Directive 99/05/EC

Manufacturer's Authorized Representative: **ALLFLEX EUROPE S.A.S.**
Route de Eaux
ZI de Plagué
B.P. 90219
35502 VITRE Cedex, FRANCE
+33 (0)2 99 75 77 00

Type of Equipment: **Short Range Device (SRD) - Low Frequency Radio Frequency Identification (RFID) Scanner**

Brand Name / Trademark: **Ailflex**

Type Designation / Model No.: **RS420-XX (XX can be 45 or 60)**

Ailflex Europe declares on its sole responsibility that the products listed above are in conformity with the essential requirements of the R&TTE Directive.

The products comply with the following harmonized European Standards or technical specifications:

Standards	Regarding
EN 301 489-3 : 2002 (V1.4.1)	EMC
EN 301 489-17 : 2009 (V2.1.1)	EMC
EN 300 330-2 (V1.5.1)	Radio Spectrum
EN 300 328 (V1.7.1)	Radio Spectrum
EN 62311 : 2008	Radio Spectrum
EN 50364 : 2001	Radio Spectrum
IEC/EN 60950-1 : 2006	Safety / Health

Ailflex Europe has an internal production control system that ensures compliance between the manufactured products and the technical documentation.

August 27, 2012

By: _____

Dominique BOIRON
Ailflex Europe - RFID Director

Trademark Notices

Bluetooth® is a registered trademark of Bluetooth SIG, Inc.

Allflex Offices

<p>Allflex UK Ltd. Unit 6 - 8 Galalaw Business Park HAWICK United Kingdom TD9 8PZ Phone: 44 (0) 1450 364120 Fax: 44 (0) 1450 364121 www.allflex.co.uk</p>	<p>Allflex Europe S. A. ZI DE Plague Route des Eaux 35502 Vitre, France Téléphone/Phone: 33 (0)2 99 75 77 00. Télécopieur/Fax: 33 (0)2 99 75 77 64 www.allflex-europe.com</p>
<p>Allflex USA, Inc. P.O. Box 612266 2805 East 14th Street Dallas Ft. Worth Airport, Texas 75261-2266 United States of America (800) 989-TAGS [8247] (972) 456-3686 (972) 456-3882/FAX www.allflexusa.com</p>	
<p>Allflex International Do Brasil Ltda. Rua Monte serrat, 1097 CEP 03312-001 Tatuape, SP, Brazil Phone/Fax: (55) 11 6942-7008 www.allflex.com.br</p>	<p>Allflex Argentina S.A. Las Heras 1588 1641 Martinez Buenos Aires, Argentina Phone/Fax: 54 11 4792 3488</p>
<p>Allflex Beijing Plastics No. 3 Heng Qu Tiao Dong Tie Jiang Ying Feng Tai District Beijing, China 100078 Phone: 861 762 9541 Fax: 861 762 9514</p>	<p>Allflex Australia 33-35 Neumann Road Capalaba Queensland 4157 Australia Phone: 61 7 3245 9100 Fax: 61 7 3245 9110 www.allflex.com.au</p>
<p>Allflex New Zealand Private Bag 11003 17 El Prado Drive Palmerston North Phone: 64 6 3567199 Fax: 64 6 3553421 www.allflex.co.nz</p>	<p>Allflex Canada Corporation Allflex Inc. 4135, Bérard St-Hyacinthe, Québec J2S 8Z8 Canada Téléphone/Phone: (450) 261-8008 Télécopieur/Fax: (450) 261-8028</p>