



User Manual
For

Wireless Mini PCI Adapter

(Atheros AR9223)

Model Number : WMP-N09H

Revision: 1.3

This document contains confidential proprietary information and is the property of Alpha Networks Inc.. The contents of this document may not be disclosed to unauthorized persons without the written consent of Alpha Networks Inc..

Operation Manual

Test Utility Installation:

1. Unzip “ ART_v0_7_b27_ar928xALL
2. The utility must run on WinXP or Vista

Hardware Installation:

Before insert the card, please execute the below instruction at first!!

1. WinXP OS:

Enter in the directory: `C:\v0_7_b27_ar928xALL\art_driver\bin\xp`

Execute the `uninst_old_drv.bat`:

Execute the `inst_new_drv_xp.bat`

Vista OS:

Enter in the directory: `C:\v0_7_b27_ar928xALL\art_driver\bin\Vista`

Execute the `uninst_old_drv.bat`:

Execute the `inst_new_drv_xp.bat`

2. Insert the card, then install the driver, the driver is located at

WinXP OS and Vista OS:

`C:\v0_7_b27_ar928xALL\art\bin`

Configuration:

1. Enter the DOS command mode, then change the directory to:

`C:\v0_7_b27_ar928xALL\art\bin`

2. Input the instruction: `art lid=2091`

Then press enter.

ART TEST MODE:

1. Once utility is executed, a menu with test options will appear. To run a test, press the character key that is assigned to the test option.

For example, press “c” to run the continuous transmit test, or press “r ” to run the continuous receive test.

2. Continuous Transmit Options:

- a. Before the continuous Transmit test, need to press “e” first

The command will load the calibrate data to the EPROM, and then the card can transmit the target power.

- b. The channel frequency, data rate and output power could be changed in continuous transmit options. Press “c” to increase the output power, 11g Power (data rate 6Mbps) is 18dBm, 11b Power is 17dBm, press ESC to return to the main Test Options menu when finished.

```
C:\WINDOWS\system32\cmd.exe
=====
: Continuous Transmit Options
: p - Increase Center Frequency by 5 MHz
: l - Decrease Center Frequency by 5 MHz
: 4 - Toggle HT40 Mode
: o - Increase Data Rate <O - next rate mode>
: k - Decrease Data Rate <K - last rate mode>
: i - Increase pcdac <I inc by 10>
: j - Decrease pcdac <J dec by 10>
: f - Increase power output by 0.5dBm <F inc by 5dBm>
: c - Decrease power output by 0.5dBm <C dec by 5dBm>
: u - Increase ob by 1 <u - increase b-ob>
: h - Increase db by 1 <h - increase b-db>
: s - Toggle output mode <tx100 ! tx99 ! single carrier>
: d - Toggle Data Pattern
: z - Toggle Scramble mode
: ; - Cycle up dac IQ constant values <511 - 2047> <; - down>
: ! - Enter STBC mode
: ESC - exit
=====

Operating in 11g at channel 2.412GHz, Chain masks: 0x3<Tx>, 0x3<Rx>

Power control mode:
PCDAC = 30, ext power detector = 0, xpdGain = 3,
ob = 4, db = 4, h_ob = 3, h_db = 3,
ANT_A, [TX99], Rate = 6 Mbps, PM9 PDADC0 = 0, PDADC1 = 0, PDADC2 = 0,
STBCIOFF] gain0 = 3, gain1 = 3, gain2 = 0
dacgn0 = 0, dacgn1 = 0, dacgn2 = 0
```

3. Continuous Receive Options

Continuous receiver option will put the radio into receive mode to allow for radio measurement. Press ESC to return to the main Test Option menu when finished.

```
C:\WINDOWS\system32\cmd.exe
=====
: Continous RF Receive Options
: p - Increase Center Frequency by 10 MHz <P inc by 100 MHz>
: l - Decrease Center Frequency by 10 MHz <L dec by 100 MHz>
: 4 - Toggle HT40 Mode
: i - Increase rx Gain <I inc by 10>
: j - Decrease rx Gain <J dec by 10>
: d - Toggle analog rx outputs
: ESC - exit
=====

Operating in 11g at channel 2.412GHz, Chain masks: 0x3<Tx>, 0x3<Rx>

ANT_A

ocIdx..... <60>
val..... <0xdeadbeef>
lnaOn..... <0x1>
lnaGain..... <0xf>
rfvg5Gain.... <0x1>
rfGmCn..... <0x5>
rx6dBLoqGain. <0x3>
rx1dBLoqGain. <0x3>
rx6dBHiqGain. <0x3>

RxGain set to 60 [RxGain Table the gain range is 0 to 104]
Analog Receive Outputs are OFF
```

1.0 Scope

1.1 Document

This document is to specify the product requirements for **802.11n Draft 2.0 Mini PCI**. This mPCI is based on Atheros chip that complied with IEEE 802.11n Draft 2.0 from 2.4~2.5GHz, and it is also backward compatible to comply with IEEE 802.11g and IEEE 802.11b standard to connect your exist 802.11 b/g wireless LAN device.

1.2 Product Features

- Compatible with IEEE 802.11g high rate standard to provide wireless 54Mbps data rate
- Compatible with IEEE 802.11b high rate standard to provide wireless 11Mbps data rate
- Compatible with IEEE 802.11n draft standard to provide wireless 300Mbps data rate
- Operation at 2.4 ~ 2.4835GHz frequency band to meet worldwide regulations
- Dynamic data rate scaling at 6, 9, 12, 18, 24, 36, 48, 54Mbps for IEEE 802.11g
- Dynamic data rate scaling at 1, 2, 5.5, and 11Mbps for IEEE 802.11b
- Dynamic data rate of IEEE 802.11n scaling from MCS – 0 to MCS –15 as shown in Appendix I
- Supports WEP, 802.1x, WPA and WPA2 enhanced security
- Friendly user configuration and diagnostic utilities
- Support Linux driver.
- Supports Mini-PCI Type IIIA form factor

2.0 Requirements

The following sections identify the detailed requirements of the **802.11n Draft 2.0 mPCI**.

2.1 Functional Block Diagram

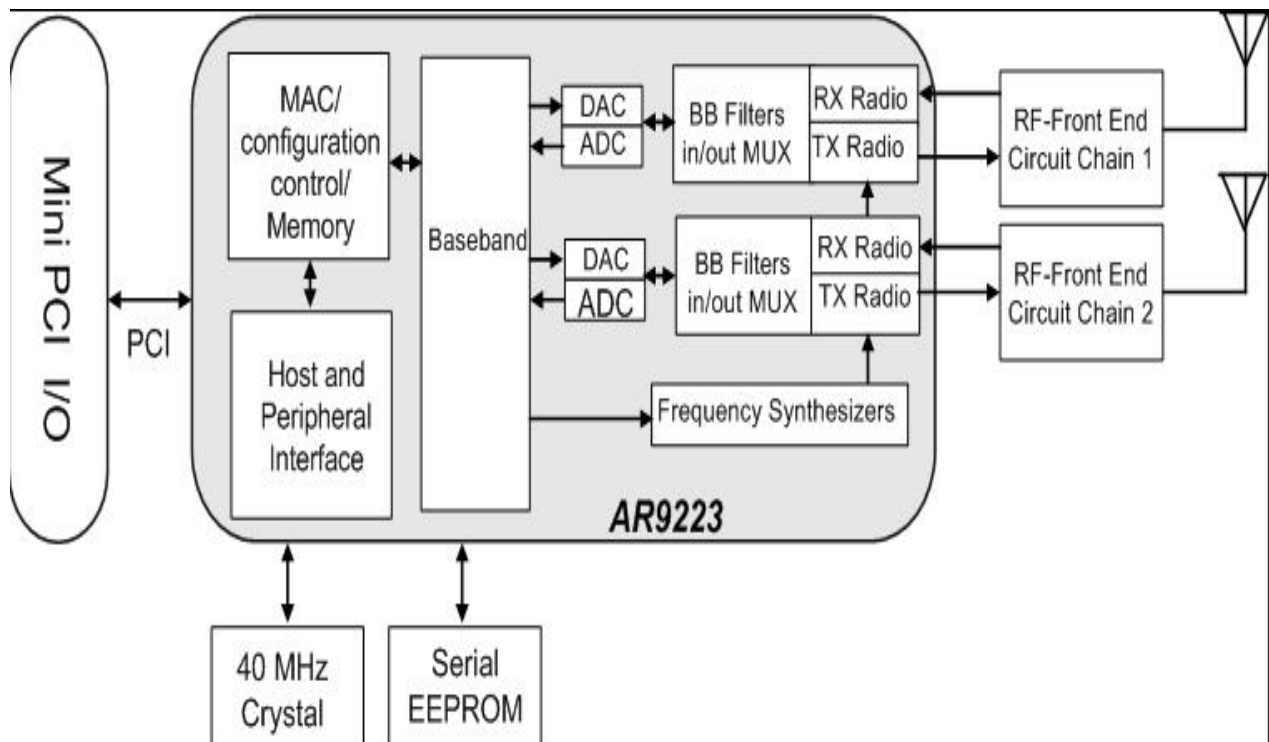

2.2 General Requirements

2.2.1 IEEE 802.11b Section

#	Feature	Detailed Description
2.2.1.1	Standard	<ul style="list-style-type: none"> IEEE 802.11b
2.2.1.2	Radio and Modulation Schemes	<ul style="list-style-type: none"> DQPSK, DBPSK, DSSS, and CCK
2.2.1.3	Operating Frequency	<ul style="list-style-type: none"> 2400 ~ 2483.5MHz ISM band
2.2.1.4	Channel Numbers	<ul style="list-style-type: none"> 11 channels for United States/ Canada/ Taiwan 13 channels for Europe Countries 14 channels for Japan
2.2.1.5	Data Rate	<ul style="list-style-type: none"> 11, 5.5, 2, and 1Mbps
2.2.1.6	Media Access Protocol	<ul style="list-style-type: none"> CSMA/CA with ACK
2.2.1.7	Transmitter Output Power	<ul style="list-style-type: none"> 802.11b: 557.3mW
2.2.1.8	Receiver Sensitivity	<ul style="list-style-type: none"> Typical Sensitivity at Which Frame (1000-byte PDUs) Error Rate = 8% Typical -84dBm for 11Mbps @ 8% PER Typical -90dBm for 2Mbps @ 8% PER

2.2.2 IEEE 802.11g Section

#	Feature	Detailed Description
2.2.2.1	Standard	<ul style="list-style-type: none"> IEEE 802.11g
2.2.2.2	Radio and Modulation Type	<ul style="list-style-type: none"> BPSK, QPSK, 16QAM, 64QAM with OFDM
2.2.2.3	Operating Frequency	<ul style="list-style-type: none"> 2400 ~ 2483.5MHz ISM band
2.2.2.4	Channel Numbers	<ul style="list-style-type: none"> 11 channels for United States/ Canada/ Taiwan 13 channels for Europe Countries 13 channels for Japan
2.2.2.5	Data Rate	<ul style="list-style-type: none"> 6,9,12,18,24,36,48,54Mbps
2.2.2.6	Media Access Protocol	<ul style="list-style-type: none"> CSMA/CA with ACK
2.2.2.7	Transmitter Output Power	<ul style="list-style-type: none"> 802.11g: 677.9mW
2.2.2.8	Receiver Sensitivity	<ul style="list-style-type: none"> Typical Sensitivity at Which Frame (1000-byte PDUs) Error Rate = 10% -87dBm at 6Mbps -87dBm at 9Mbps -84dBm at 12Mbps -82dBm at 18Mbps -79dBm at 24Mbps -75dBm at 36Mbps -71dBm at 48Mbps -70dBm at 54Mbps

2.2.3 IEEE 802.11n Section

#	Feature	Detailed Description
2.2.3.1	Standard	<ul style="list-style-type: none"> IEEE 802.11n Draft 2.0
2.2.3.2	Radio and Modulation Type	<ul style="list-style-type: none"> BPSK, QPSK, 16QAM, 64QAM with OFDM
2.2.3.3	Operating Frequency	<ul style="list-style-type: none"> 2400 ~ 2483.5MHz ISM band

#	Feature	Detailed Description
2.2.3.4	Channel Numbers	<ul style="list-style-type: none"> 11 channels for United States/ Canada/ Taiwan 13 channels for Europe Countries 13 channels for Japan
2.2.3.5	Data Rate	<ul style="list-style-type: none"> From MCS – 0 to MCS –15 as shown in Appendix I
2.2.3.6	Media Access Protocol	<ul style="list-style-type: none"> CSMA/CA with ACK
2.2.3.7	Transmitter Output Power	<ul style="list-style-type: none"> draft 802.11n (20MHz): 577.4mW draft 802.11n (40MHz): 328.7mW
2.2.3.8	Receiver Sensitivity	<ul style="list-style-type: none"> Typical Sensitivity at Which Frame (1000-byte PDUs) Error Rate = 10% <p>HT20</p> <ul style="list-style-type: none"> -88dBm at MCS0 -84dBm at MCS1 -81dBm at MCS2 -78dBm at MCS3 -75dBm at MCS4 -70dBm at MCS5 -69dBm at MCS6 -68dBm at MCS7 <p>HT40</p> <ul style="list-style-type: none"> -85dBm at MCS0 -81dBm at MCS1 -78dBm at MCS2 -75dBm at MCS3 -72dBm at MCS4 -67dBm at MCS5 -66dBm at MCS6 -65dBm at MCS7

2.2.4 General Section

#	Feature	Detailed Description
2.2.4.1	Antenna Connector	<ul style="list-style-type: none"> Two UFL antenna connectors
2.2.4.2	Operating Voltage	<ul style="list-style-type: none"> 3.3VDC +/- 10%
2.2.4.3	Current Consumption	<ul style="list-style-type: none"> 650mA at continuous transmit mode (2 Tx chains on) 250mA at continuous receive mode (2 Rx chains on)
2.2.4.4	Form Factor and Interface	<ul style="list-style-type: none"> Mini-PCI Type IIIA form factor
2.2.4.5	LEDs	<ul style="list-style-type: none"> External LED function supported

2.3 Software Requirements

The Configuration Software supports Linux driver. This configuration software includes the following functions:

- **Information**
Information allows you to monitor network status.
- **Configuration**
Configuration allows you to configure parameters for wireless networking.
- **Security**
Supports enhanced security WEP, 802.1x, WPA and WPA2.

2.3.1 Security

#	Feature	Detailed Description
2.3.1.1	Encryption	<ul style="list-style-type: none"> • RC4 encryption algorithm • Support 64-bit and 128-bit WEP encryption • Support open system (OSA) and shared key authentication (SKA)
2.3.1.2	WEP Management	<ul style="list-style-type: none"> • Four WEP keys can be selected • STA with WEP off will never associate any AP with WEP enabled • WEP Key Format: Option for Hex format
2.3.1.3	802.1x	<ul style="list-style-type: none"> • Support EAP-TLS, EAP-TTLS, and EAP-PEAP
2.3.1.4	WPA/WPA2	<ul style="list-style-type: none"> • Support WPA/WPA2-PSK and WPA/WPA2-EAP • Support Cipher Mode AES and TKIP

2.4 Mechanical Requirements

#	Feature	Detailed Description
2.4.1	Length	<ul style="list-style-type: none"> • 60.00 mm
2.4.2	Width	<ul style="list-style-type: none"> • 51.00 mm
2.4.3	Height	<ul style="list-style-type: none"> • 3.3mm

2.5 Compatibility Requirements

This device passes the following compatibility requirements.

#	Feature	Detailed Description
2.5.1	Wi-Fi	<ul style="list-style-type: none"> • Meet Wi-Fi certification for IEEE 802.11b/g/n product
2.5.2	WHQL	<ul style="list-style-type: none"> • Meet applicable WHQL certification requirements
2.5.3	Physical Layer and Functionality	<ul style="list-style-type: none"> • Meet ALPHA Engineering Test Plan and Test Report

2.6 Requirements of Reliability, Maintainability and Quality

#	Feature	Detailed Description
2.6.1	MTBF	<ul style="list-style-type: none"> • Mean Time Between Failure > 30,000 hours
2.6.2	Maintainability	<ul style="list-style-type: none"> • There is no scheduled preventive maintenance required
2.6.3	Quality	<ul style="list-style-type: none"> • The product quality is followed-up by ALPHA factory quality control system

2.7 Environmental Requirements

#	Feature	Detailed Description
2.7.1	Operating Temperature Conditions	<ul style="list-style-type: none"> • The product is capable of continuous reliable operation when operating in ambient temperature of 0 °C to +50°C.

#	Feature	Detailed Description
2.7.2	Non-Operating Temperature Conditions	<ul style="list-style-type: none"> Neither subassemblies is damaged nor the operational performance is degraded when restored to the operating temperature after exposing to storage temperature in the range of -20°C to $+75^{\circ}\text{C}$.
2.7.3	Operating Humidity conditions	<ul style="list-style-type: none"> The product is capable of continuous reliable operation when subjected to relative humidity in the range of 10% and 90% non-condensing.
2.7.4	Non-Operating Humidity Conditions	<ul style="list-style-type: none"> The product is not damaged nor the performance is degraded after exposure to relative humidity ranging from 5% to 95% non-condensing

Appendix I:

Rate Dependent Parameters for High Throughput . Modulation and Coding Schemes (MCS)

Table 1 - Modulation and Coding Schemes

Bits 0-6 in HT- SIG1 (MCS index)	Number of spatial streams	Modulation	Coding rate	NES		NSD		NCBPS		GI = 800ns		GI = 400ns	
				20	40	20	40	20MH z	40MH z	Rate in	Rate in	Rate in	Rate in
										20MHz	40MHz	20MHz	40MHz
0	1	BPSK	½	1	1	52	108	52	108	6.5	13.5	7 2/9	15
1	1	QPSK	½	1	1	52	108	104	216	13	27	14 4/9	30
2	1	QPSK	¼	1	1	52	108	104	216	19.5	40.5	21 2/3	45
3	1	16-QAM	½	1	1	52	108	208	432	26	54	28 8/9	60
4	1	16-QAM	¼	1	1	52	108	208	432	39	81	43 1/3	90
5	1	64-QAM	⅓	1	1	52	108	312	648	52	108	57 7/9	120
6	1	64-QAM	¼	1	1	52	108	312	648	58.5	121.5	65	135
7	1	64-QAM	5/6	1	1	52	108	312	648	65	135	72 2/9	150
8	2	BPSK	½	1	1	52	108	104	216	13	27	14 4/9	30
9	2	QPSK	½	1	1	52	108	208	432	26	54	28 8/9	60
10	2	QPSK	¼	1	1	52	108	208	432	39	81	43 1/3	90
11	2	16-QAM	½	1	1	52	108	416	864	52	108	57 7/9	120
12	2	16-QAM	¼	1	1	52	108	416	864	78	162	86 2/3	180
13	2	64-QAM	⅓	1	1	52	108	624	1296	104	216	115 5/9	240
14	2	64-QAM	¼	1	1	52	108	624	1296	117	243	130	270
15	2	64-QAM	5/6	1	1	52	108	624	1296	130	270	144 4/9	300

The parameters in the table are:

- Rate: Rate in Mbps
- NES: Number of FEC encoders used
- NSD: Number of Data Subcarriers
- NCBPS: Number of Code Bits Per Symbol (total of all spatial streams)
- NSS: Number of Spatial Streams

Federal Communication Commission Interference Statement

This equipment has been tested and found to comply with the limits for a Class B digital device, pursuant to Part 15 of the FCC Rules. These limits are designed to provide reasonable protection against harmful interference in a residential installation. This equipment generates, uses and can radiate radio frequency energy and, if not installed and used in accordance with the instructions, may cause harmful interference to radio communications. However, there is no guarantee that interference will not occur in a particular installation. If this equipment does cause harmful interference to radio or television reception, which can be determined by turning the equipment off and on, the user is encouraged to try to correct the interference by one of the following measures:

- Reorient or relocate the receiving antenna.
- Increase the separation between the equipment and receiver.
- Connect the equipment into an outlet on a circuit different from that to which the receiver is connected.
- Consult the dealer or an experienced radio/TV technician for help.

This device complies with Part 15 of the FCC Rules. Operation is subject to the following two conditions: (1) This device may not cause harmful interference, and (2) this device must accept any interference received, including interference that may cause undesired operation.

FCC Caution: Any changes or modifications not expressly approved by the party responsible for compliance could void the user's authority to operate this equipment.

IMPORTANT NOTE:

FCC Radiation Exposure Statement:

This equipment complies with FCC radiation exposure limits set forth for an uncontrolled environment. This equipment should be installed and operated with minimum distance 20cm between the radiator & your body.

This transmitter must not be co-located or operating in conjunction with any other antenna or transmitter.

IEEE 802.11b or 802.11g operation of this product in the U.S.A. is firmware-limited to channels 1 through 11.

This device is intended only for OEM integrators under the following conditions:

- 1) The antenna must be installed such that 20 cm is maintained between the antenna and users, and
- 2) The transmitter module may not be co-located with any other transmitter or antenna,
- 3) For all products market in US, OEM has to limit the operation channels in CH1 to CH11 for 2.4G band by supplied firmware programming tool. OEM shall not supply any tool or info to the end-user regarding to Regulatory Domain change. As long as 3 conditions above are met, further transmitter test will not be required. However, the OEM integrator is still responsible for testing their end-product for any additional compliance requirements required with this module installed (for example, digital device emissions, PC peripheral requirements, etc.).

IMPORTANT NOTE: In the event that these conditions can not be met (for example certain laptop configurations or co-location with another transmitter), then the FCC authorization is no longer considered valid and the FCC ID can not be used on the final product. In these circumstances, the OEM integrator will be responsible for re-evaluating the end product (including the transmitter) and obtaining a separate FCC authorization.

End Product Labeling

This transmitter module is authorized only for use in device where the antenna may be installed such that 20 cm may be maintained between the antenna and users. The final end product must be labeled in a visible area with the following: "Contains FCC ID: RRKWMPN09H".

Manual Information To the End User

The OEM integrator has to be aware not to provide information to the end user regarding how to install or remove this RF module in the user's manual of the end product which integrates this module.

The end user manual shall include all required regulatory information/warning as show in this manual.

Industry Canada Statement

This device complies with RSS-210 of the Industry Canada Rules. Operation is subject to the following two conditions:

- 1) this device may not cause interference and
- 2) this device must accept any interference, including interference that may cause undesired operation of the device

This device has been designed to operate with an antenna having a maximum gain of 4dBi. Antenna having a higher gain is strictly prohibited per regulations of Industry Canada. The required antenna impedance is 50 ohms.

To reduce potential radio interference to other users, the antenna type and its gain should be so chosen that the EIRP is not more than required for successful communication.

IMPORTANT NOTE:

IC Radiation Exposure Statement:

This equipment complies with IC radiation exposure limits set forth for an uncontrolled environment. This equipment should be installed and operated with minimum distance 20cm between the radiator & your body.

This device is intended only for OEM integrators under the following conditions:

The transmitter module may not be co-located with any other transmitter or antenna.

As long as conduction above is met, further transmitter test will not be required. However, the OEM integrator is still responsible for testing their end-product for any additional compliance requirements required with this module installed (for example, digital device emissions, PC peripheral requirements, etc.).

IMPORTANT NOTE: In the event that these conditions can not be met (for example certain laptop configurations or co-location with another transmitter), then the IC authorization is no longer considered valid and the IC ID can not be used on the final product. In these circumstances, the OEM integrator will be responsible for re-evaluating the end product (including the transmitter) and obtaining a separate IC authorization.

End Product Labeling

The final end product must be labeled in a visible area with the following: “Contains TX IC : 4833A-WMPN09”.

Manual Information That Must be Included

The OEM integrator has to be aware not to provide information to the end user regarding how to install or remove.

This RF module in the user’s manual of the end product which integrates this module. The user’s manual for OEM Integrators must include the following information in a prominent location “IMPORTANT NOTE: To comply with FCC RF exposure compliance requirements. The antenna must not be co-located or operating in conjunction with any other antenna or transmitter”.

以下警語適用台灣地區：

經型式認證合格之低功率射頻電機，非經許可，公司、商號或使用者均不得擅自變更頻率、加大功率或變更原設計之特性及功能。

低功率射頻電機之使用不得影響飛航安全及干擾合法通信；經發現有干擾現象時，應立即停用，並改善至無干擾時方得繼續使用。前項合法通信，指依電信法規定作業之無線電通信。低功率射頻電機須忍受合法通信或工業、科學及醫療用電波輻射性電機設備之干擾。

本模組於取得認證後將依規定於模組本體標示審合格籤，並要求平台上標示「本產品內含射頻模組：ID 編號」