

Convection Oven

Electric



ASC-2E
WITH
Mobile Stand Option 5004687



ASC-4E
WITH
Stand Option 5003489

PLATINUM SERIES

Model:

ASC-2E
ASC-4E

Manual
Control

- **INSTALLATION**
- **OPERATION**
- **MAINTENANCE**



W164 N9221 Water Street • P.O. Box 450 • Menomonee Falls, Wisconsin 53052-0450 USA
PHONE: 262.251.3800 • 800.558.8744 USA/CANADA FAX: 262.251.7067 • 800.329.8744 U.S.A. ONLY
www.alto-shaam.com

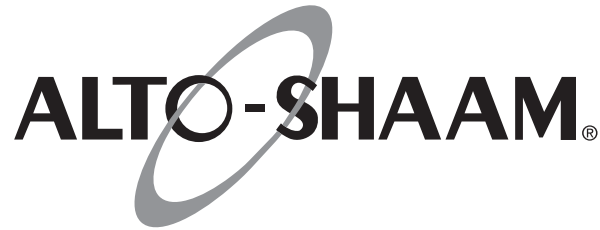

Delivery 1
Unpacking 1
Safety Procedures and Precautions. 2

Installation

Site Installation 3
Clearance Requirements 3
Dimension Drawings 4
Installation Requirements 5
Leveling 5
Restraint Requirements 5
Electrical Connection 6
Stacking Instructions. 7-8
Oven Stand Assembly Option 9

Operating Instructions

User Safety Information 10
Start-Up Operation 10
Capacity 10
Options & Accessories 10
Pan/Shelf Positioning 11
Electronic Control Operation and Features 12
Cooking Guidelines. 13

Care and Cleaning

Cleaning and Preventative Maintenance 14
Protecting Stainless Steel Surfaces 14
Cleaning Agents 14
Cleaning Materials 14
Equipment Care 15
Clean Daily. 15
Exterior. 16
Motor Care 16

Service

Troubleshooting Guide 16
ASC-2E Manual Control
Full Assembly 17
Control Assembly 18
Interior Assembly 19
ASC-4E Manual Control
Full Assembly 21
Control Assembly 22
Interior Assembly 23

Wire Diagrams

Always refer to the wire diagram(s) included with the unit for most current version.

Warranty

Transportation Damage and Claims . . . Back Cover
Limited Warranty Back Cover

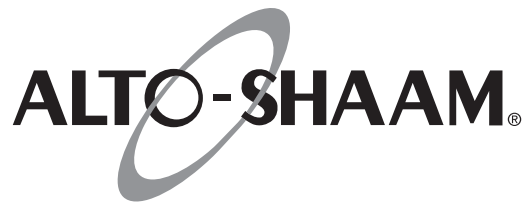

DELIVERY

This Alto-Shaam appliance has been thoroughly tested and inspected to ensure only the highest quality unit is provided. Upon receipt, check for any possible shipping damage and report it at once to the delivering carrier. *See Transportation Damage and Claims section located in this manual.*

This appliance, complete with unattached items and accessories, may have been delivered in one or more packages. Check to ensure that all standard items and options have been received with each model as ordered.

Save all the information and instructions packed with the appliance. Complete and return the warranty card to the factory as soon as possible to ensure prompt service in the event of a warranty parts and labor claim.

This manual must be read and understood by all people using or installing the equipment model. Contact the Alto-Shaam Tech Team Service Department if you have any questions concerning installation, operation, or maintenance.

NOTE: All claims for warranty must include the full model number and serial number of the unit.

UNPACKING

1. Carefully remove the appliance from the carton or crate.

NOTE: Do not discard the carton and other packaging material until you have inspected the unit for hidden damage and tested it for proper operation.

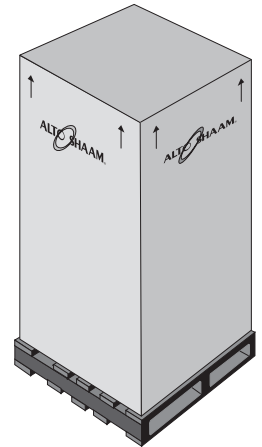

2. Read all instructions in this manual carefully before initiating the installation of this appliance.

DO NOT DISCARD THIS MANUAL.

This manual is considered to be part of the appliance and is to be provided to the owner or manager of the business or to the person responsible for training operators. *Additional manuals are available from the Alto-Shaam Tech Team Service Department.*

3. Remove all protective plastic film, packaging materials, and accessories from the appliance before connecting electrical power. Store any accessories in a convenient place for future use.

SAFETY PROCEDURES AND PRECAUTIONS

Knowledge of proper procedures is essential to the safe operation of electrically and/or gas energized equipment. In accordance with generally accepted product safety labeling guidelines for potential hazards, the following signal words and symbols may be used throughout this manual.

DANGER



Used to indicate the presence of a hazard that **WILL** cause severe personal injury, death, or substantial property damage if the warning included with this symbol is ignored.

WARNING



Used to indicate the presence of a hazard that **CAN** cause personal injury, possible death, or major property damage if the warning included with this symbol is ignored.

CAUTION



Used to indicate the presence of a hazard that can or will cause minor or moderate personal injury or property damage if the warning included with this symbol is ignored.

CAUTION

Used to indicate the presence of a hazard that can or will cause minor personal injury, property damage, or a potential unsafe practice if the warning included with this symbol is ignored.

NOTE: Used to notify personnel of installation, operation, or maintenance information that is important but not hazard related.

1. This appliance is intended to cook, hold or process foods for the purpose of human consumption. No other use for this appliance is authorized or recommended.
2. This appliance is intended for use in commercial establishments where all operators are familiar with the purpose, limitations, and associated hazards of this appliance. Operating instructions and warnings must be read and understood by all operators and users.
3. Any troubleshooting guides, component views, and parts lists included in this manual are for general reference only and are intended for use by qualified technical personnel.
4. This manual should be considered a permanent part of this appliance. This manual and all supplied instructions, diagrams, schematics, parts lists, notices, and labels must remain with the appliance if the item is sold or moved to another location.

NOTE

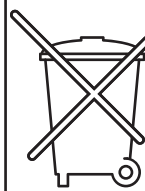

For equipment delivered for use in any location regulated by the following directive:

DO NOT DISPOSE OF ELECTRICAL OR ELECTRONIC EQUIPMENT WITH OTHER MUNICIPAL WASTE.

INSTALLATION

DANGER



IMPROPER INSTALLATION, ALTERATION, ADJUSTMENT, SERVICE, OR MAINTENANCE COULD RESULT IN SEVERE INJURY, DEATH, OR CAUSE PROPERTY DAMAGE.

READ THE INSTALLATION, OPERATING AND MAINTENANCE INSTRUCTIONS THOROUGHLY BEFORE INSTALLING OR SERVICING THIS EQUIPMENT.

CAUTION



DO NOT LIFT OR MOVE THE OVEN BY USING THE DOORS OR THE DOOR HANDLES.

CAUTION



METAL PARTS OF THIS EQUIPMENT BECOME EXTREMELY HOT WHEN IN OPERATION. TO AVOID BURNS, ALWAYS USE HAND PROTECTION WHEN OPERATING THIS APPLIANCE.



DANGER



DO NOT store or use gasoline or other flammable vapors or liquids in the vicinity of this or any other appliance.

SITE INSTALLATION

The Alto-Shaam convection oven must be installed in a location that will permit the oven to function for its intended purpose and to allow adequate clearance for ventilation, proper cleaning, and maintenance.

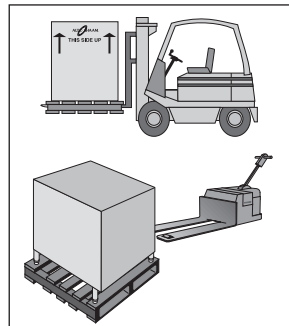

- Hood installation is recommended. (CHECK LOCAL CODES).
- The oven must be installed on a stable and level surface.
- DO NOT** install this oven in any area where it may be affected by any adverse conditions such as steam, grease, dripping water, high temperatures, etc.
- DO NOT** store or use any flammable liquids or allow flammable vapors in the vicinity of this oven or any other appliance.
- This appliance must be kept free and clear of any combustible materials.
- This appliance must be kept free and clear of any obstructions blocking access for maintenance or service.

ASC-2E • WEIGHT

NET: 203 lb (92 kg)	SHIP: 278 lb (126 kg)
CRATE DIMENSIONS:	35" L x 35" W x 41" H (889mm x 889mm x 1041mm)
MINIMUM ENTRY CLEARANCE	31-1/2" (800mm) UNCRATED
ASC-2E • DIMENSIONS: H x W x D	
EXTERIOR:	32-1/8" x 30" x 30-1/8" (815mm x 762mm x 815mm)
INTERIOR:	20" x 15" x 21" (508mm x 381mm x 533mm)

ASC-4E • WEIGHT

NET: 490 lb (222 kg)	SHIP: 535 lb (243 kg)
CRATE DIMENSIONS:	53" L x 45" W x 49" H (1346mm x 1143mm x 1245mm)
MINIMUM ENTRY CLEARANCE	31-1/2" (800mm) UNCRATED
ASC-4E • DIMENSIONS: H x W x D	
EXTERIOR:	57-1/2" x 38" x 44-1/2" (1461mm x 965mm x 1130mm)
INTERIOR:	24" x 29-1/8" x 25" (610mm x 740mm x 635mm)

MINIMUM CLEARANCE REQUIREMENTS

BACK:	0" (0mm)
LEFT SIDE:	2" (51mm)
RIGHT SIDE:	2" (51mm)
FROM GREASE PRODUCING EQUIPMENT:	6" (152mm)
RECOMMENDED SERVICE ACCESS:	20" (508mm) right side

INSTALLATION

EXTERIOR DIMENSIONS

ASC-2E

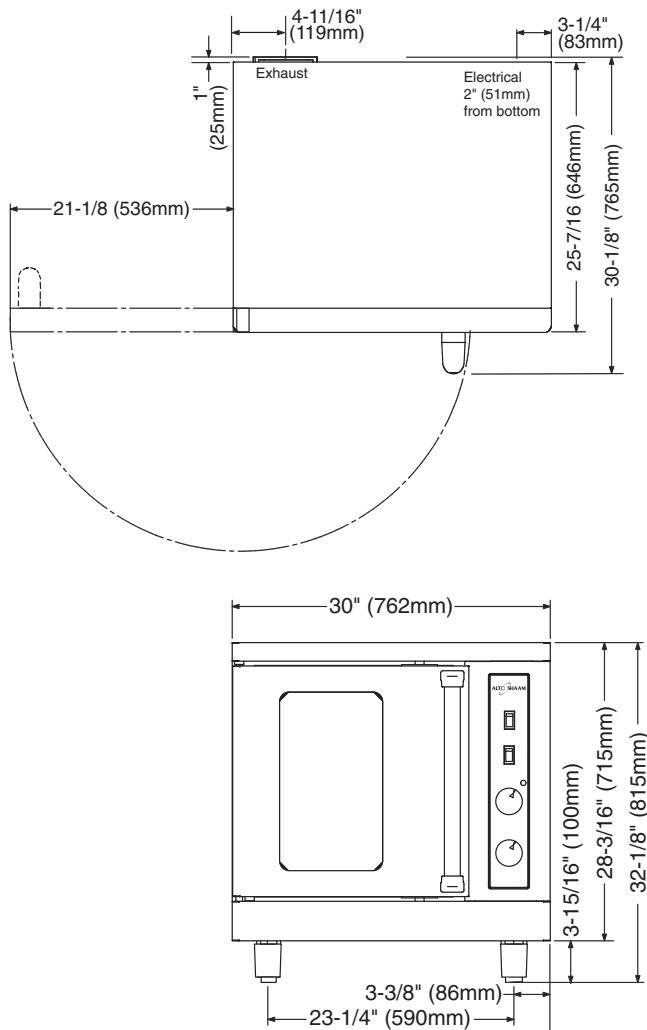

ASC-2E • PRODUCT/PAN CAPACITY

27 lb (12 kg) MAXIMUM — 17 qts (15 liters)

Nine (9): 18" x 13" x 1" half-size sheet pans

5 chrome plated wire shelves with
2 removable side racks and 9 shelf positions
spaced at 1-5/8" (41mm)

ASC-4E

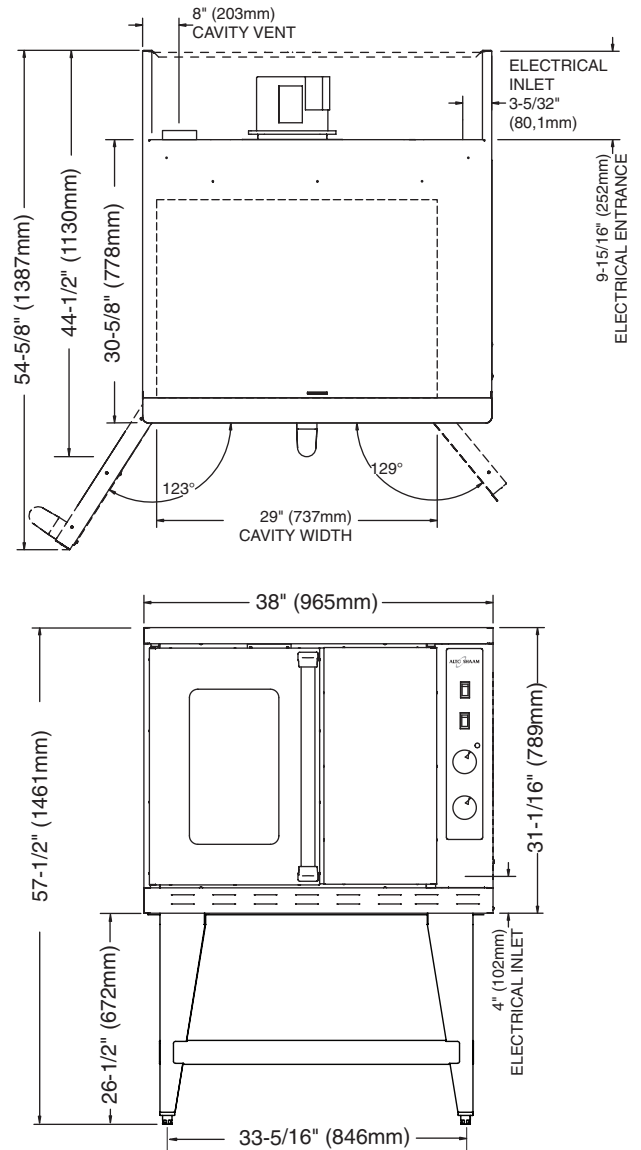

ASC-4E • PRODUCT/PAN CAPACITY

72 lb (33 kg) maximum • 45 qts (43 liters)

Twelve (12): 18" x 26" x 1" full-size sheet pans

6 chrome plated wire shelves with
2 removable side racks and 12 shelf positions
spaced at 1-3/4" (43mm)

INSTALLATION

INSTALLATION REQUIREMENTS

The oven must be mounted on the factory equipped oven legs or on an optional oven stand. Installation on a solid or concrete base that in any way restricts air flow may void the warranty.

All clearances for a proper ventilation air supply must be maintained to minimize fire hazard. Do not locate the oven immediately adjacent to any other heat-generating appliance.

DANGER



IMPROPER INSTALLATION, ALTERATION, ADJUSTMENT, SERVICE, OR MAINTENANCE COULD RESULT IN SEVERE INJURY, DEATH, OR CAUSE PROPERTY DAMAGE.

READ THE INSTALLATION, OPERATING AND MAINTENANCE INSTRUCTIONS THOROUGHLY BEFORE INSTALLING OR SERVICING THIS EQUIPMENT.

A number of adjustments are associated with initial installation and start-up. Adjustments must be conducted by a qualified service technician. Installation and start-up adjustments are the responsibility of the dealer or user. These adjustments include but are not limited to thermostat calibration, door adjustment, and leveling. The Platinum series oven burners are factory-adjusted with fixed air openings and require no field adjustment.

LEVELING



The oven should be leveled before the gas supply is connected. Level the oven from side-to-side and front-to-back with the use of a spirit level. For ovens installed on a mobile stand, it is important that the floor surface be level due to the probability of frequent oven repositioning.

We recommend checking the level of the oven periodically to make certain the floor has not shifted nor the oven moved.

Where automatically operated appliances are vented through a ventilating hood or exhaust system equipped with a damper or with a power means of exhaust, provisions shall be made to allow the equipment to operate only when the damper is open to a position to properly vent the appliance and when the power means of exhaust is in operation. ACCORDANCE WITH NFPA 54 COMMONWEALTH OF MASSACHUSETTS ONLY.

CAUTION



TO PREVENT PERSONAL INJURY, USE CAUTION WHEN MOVING OR LEVELING THIS APPLIANCE.

RESTRAINT REQUIREMENTS —MOBILE EQUIPMENT



WARNING



RISK OF ELECTRIC SHOCK.

Appliance must be secured to building structure.

Any appliance that is not furnished with a power supply cord but includes a set of casters must be provided with a tether. Adequate means must be provided to limit the movement of this appliance without depending on or transmitting stress to the electrical conduit. The following requirements apply:

1. Casters must be a maximum height of 6" (152mm).
2. Two of the casters must be the locking type.
3. Such mobile appliances or appliances on mobile stands must be installed with the use of a flexible connector secured to the building structure.

A mounting connector for a restraining device is located on the lower back flange of the appliance chassis or on an oven stand, approximately 18" (457mm) from the floor. A flexible connector is not supplied or available from the factory.

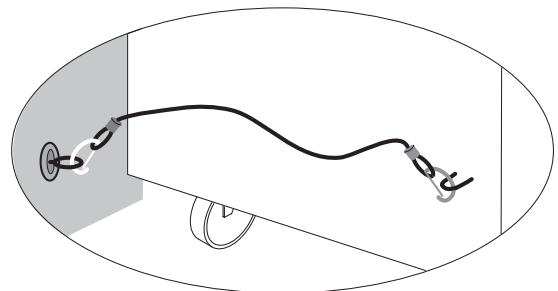

INSTALLATION

ELECTRICAL CONNECTION

⚠ DANGER

ELECTRICAL CONNECTIONS MUST BE MADE BY A QUALIFIED SERVICE TECHNICIAN IN ACCORDANCE WITH APPLICABLE ELECTRICAL CODES.

⚠ DANGER

ENSURE POWER SOURCE MATCHES VOLTAGE STAMPED ON APPLIANCE NAMEPLATE.

The oven must be installed by a qualified electrician. This appliance must be branch circuit protected with proper ampacities, in accordance with the wiring diagram located in this manual or in the electrical compartment of the oven. The oven must be properly grounded in accordance with the National Electrical Code and applicable local codes.

Wire size for the main incoming power to the unit must match the minimum size listed in the specifications applicable to the specific oven model. For supply connections, locate the wire size posted on the label located near the electric terminal block behind the service panel or elsewhere listed in this manual. Before attempting the electrical connection, the rating plate should be checked to ensure that the electrical characteristics of the appliance and the electrical supply characteristics agree.

DANGER

To avoid electrical shock, this appliance MUST be adequately grounded in accordance with local electrical codes or, in the absence of local codes, with the current edition of the National Electrical Code ANSI/NFPA No. 70. In Canada, all electrical connections are to be made in accordance with CSA C22.1, Canadian Electrical Code Part 1 or local codes.

Installation of the wiring must be made in accordance with U.L. 197 Commercial Electric Cooking Appliance Standards, Local and/or National Electrical Code, ANSI /NFPA 70-1990.

Plug the unit into a properly grounded receptacle **ONLY**, positioning the unit so that the plug is easily accessible in case of an emergency. Arcing will occur when connecting or disconnecting the unit unless all controls are in the “off” position.

Service line entry is made through the rear of the oven for connection to the terminal block. Remove the service panel on the right side of the oven for access to the terminal block.

Proper receptacle or outlet configuration or permanent wiring for this unit must be installed by a licensed electrician in accordance with applicable local electrical codes.

The oven is wired at the factory for either single phase or three phase service as indicated on the original purchase order. Input voltage and phase must match the voltage and phase of the oven. Visually check all electrical connections.

ELECTRICAL • ASC-2E					
VOLTAGE	PHASE	CYCLE/HZ	AWG	AMPS	kW
208 (AGCY)	1	60	10	24.0	5.0
240 (AGCY)	1	60	10	20.8	5.0
208 (AGCY)	3	60	12	13.8	5.0
240 (AGCY)	3	60	12	12.0	5.0
NO CORD AND PLUG					

ELECTRICAL • ASC-4E					
VOLTAGE	PHASE	CYCLE/HZ	AWG	AMPS	kW
208 (AGCY)	1	60	6	50.0	10.4
240 (AGCY)	1	60	6	43.3	10.4
208 (AGCY)	3	60	8	28.8	10.4
240 (AGCY)	3	60	8	25.0	10.4
480 (AGCY)	3	60	8	12.5	10.4
220 (AGCY)	1	50	6	40.0	8.7
NO CORD AND PLUG					

Wire diagrams are located in the inside access panel of the unit

INSTALLATION

STACKING & VENTING ASSEMBLY (2-ASC-2E/STK SHOWN)

SCREW SC-2351 QTY2
IN THIS LOCATION ON
BOTTOM UNIT.

REMOVE KNOCKOUT PRIOR
TO STACKING TOGETHER.
BOLT UP AND INTO
TOP UNIT

ADD
1006412
VENT RISER

SCREW SC-26520 QTY 5

REMOVE EXISTING VENT

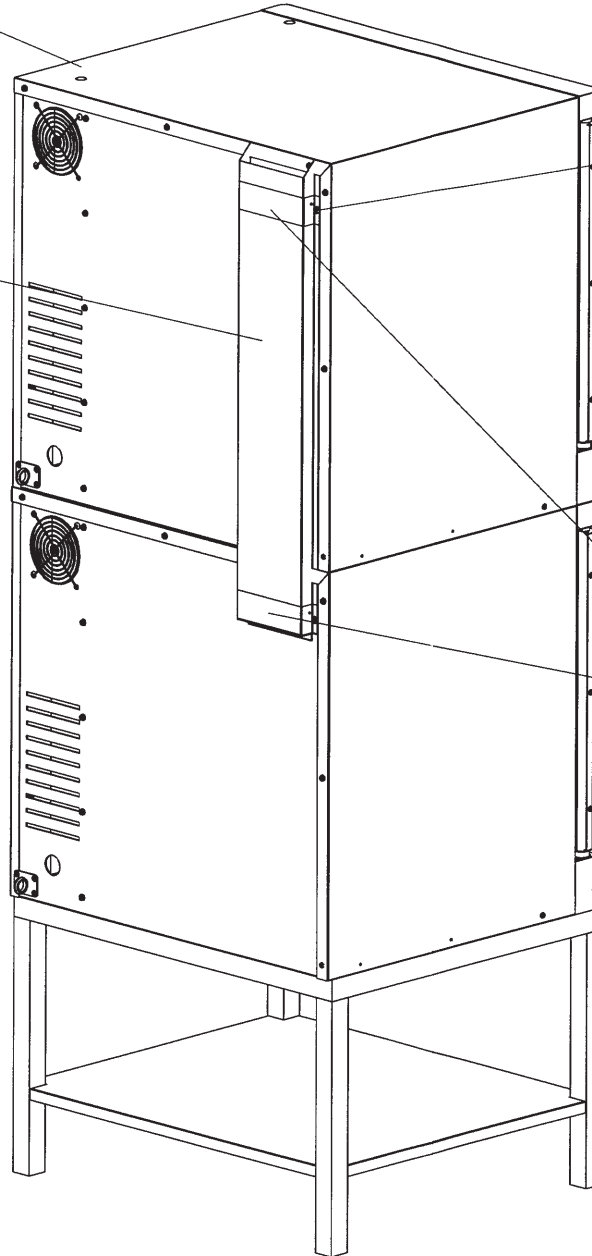

Note: Actual unit may be
different than shown.

CAUTION



TO PREVENT PERSONAL INJURY,
USE CAUTION WHEN MOVING OR
LEVELING THIS APPLIANCE.

Part numbers and drawings are subject to change without notice.

INSTALLATION

STACKING & VENTING ASSEMBLY (2-ASC-4E/STK 208/240V SHOWN)

ITEM	DESCRIPTION	PART NO.	QTY
2	RISER, FLUE ELECTRIC	1004984	1
3	SCREW, #10 SMS .5LG	SC-26520	5

Note: Actual unit may be different than shown.

After legs or casters have been installed on the bottom oven, place the upper oven on top of lower unit. Align.

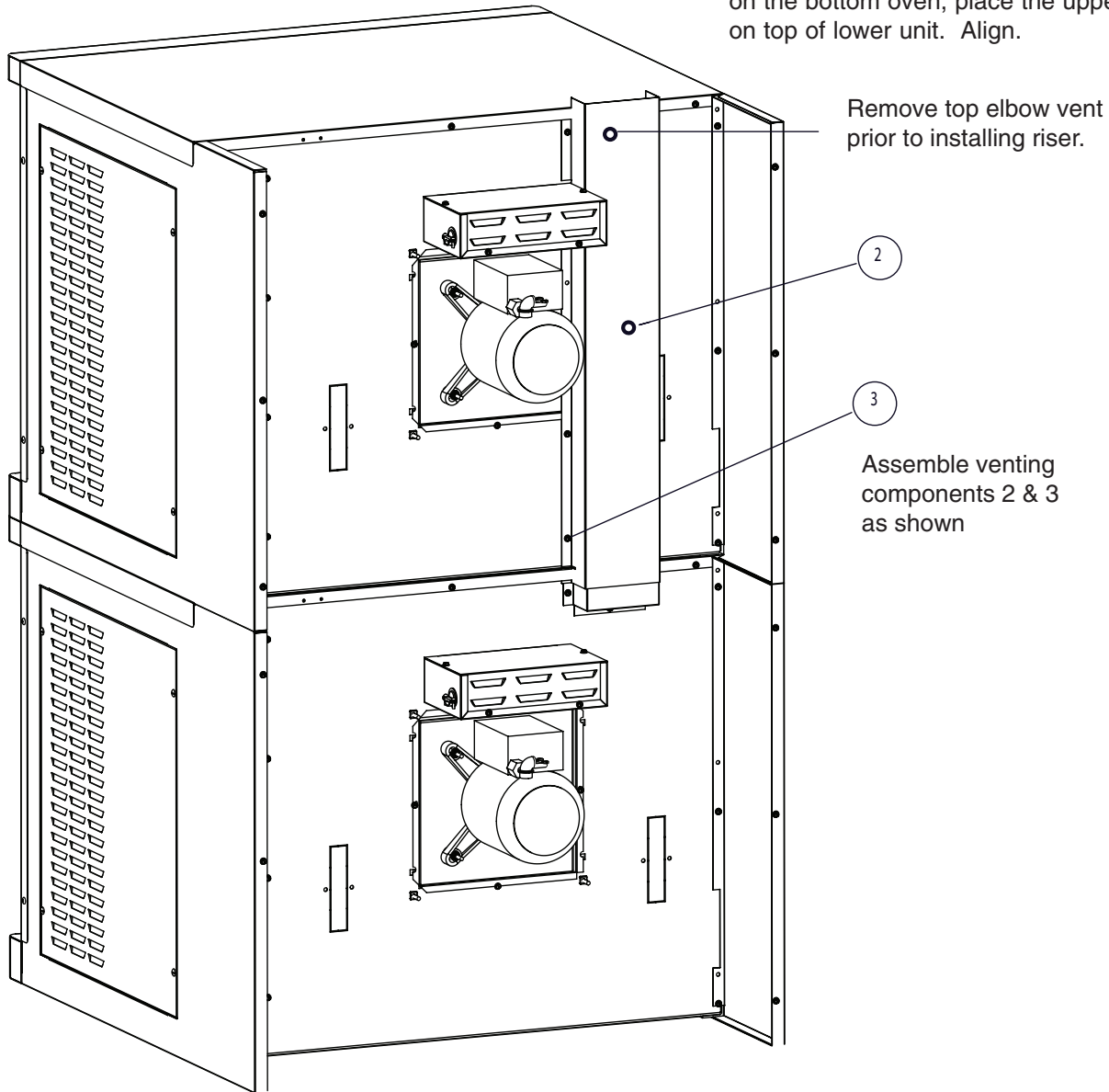

CAUTION



**TO PREVENT PERSONAL INJURY,
USE CAUTION WHEN MOVING OR
LEVELING THIS APPLIANCE.**

Part numbers and drawings are subject to change without notice.

INSTALLATION

OVEN STAND ASSEMBLY

OVEN STAND 5003489 SHOWN

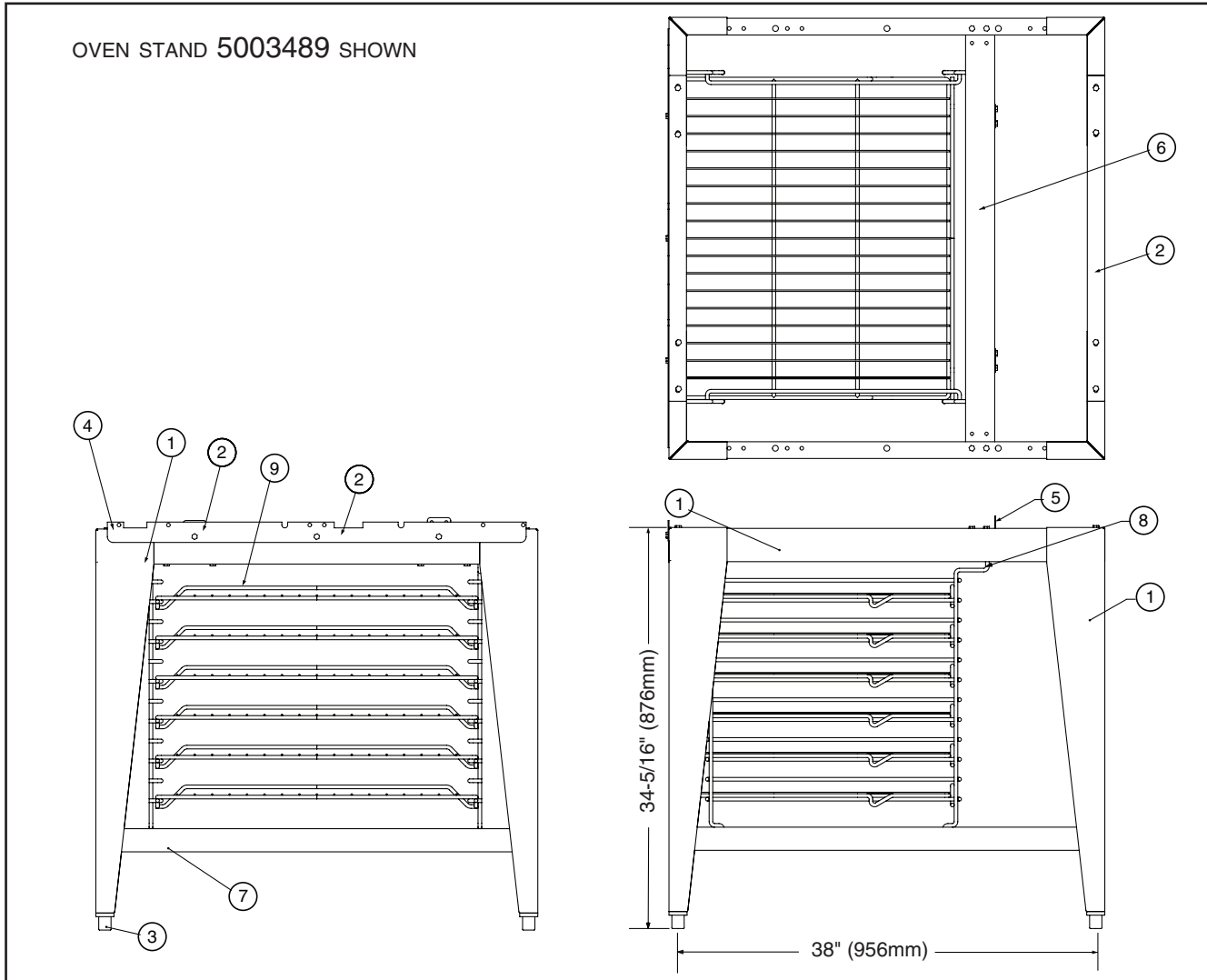

ITEM	DESCRIPTION	PART NO.	QTY
1	LEG SUPPORT ASSEMBLY	5003488	2
2	CHANNEL, SUPPORT	1004459	2
3	LEG	LG-22185	4
	*CASTERS, RIGID	CS-25674	2
	*CASTERS, SWIVEL W/BRAKE	CS-25675	2
4	BRACKET, STAND	1004461	1
5	BRACKET, ATTACHMENT	1004369	2
6	CHANNEL, BACK	1004460	1
7	SHELF, STAND	1004466	1
8	RACK, OVEN SUPPORT	SR-26551	2
9	OVEN RACK	SH-26795	6
10	*SCREWS, 1/4-20 X 1/2 HEX HEAD	SC-22729	27
11	*NUT, 1/4-20 NYLON INSERT, 18-8 S/S	NU-23984	27
12	*LOCK WASHER, 1/4" STAINLESS STEEL	WS-2294	27

*NOT SHOWN

Part numbers and drawings are subject to change without notice.

OPERATING INSTRUCTIONS

USER SAFETY INFORMATION

START-UP OPERATION

CAUTION



METAL PARTS OF THIS EQUIPMENT BECOME EXTREMELY HOT WHEN IN OPERATION. TO AVOID BURNS, ALWAYS USE HAND PROTECTION WHEN OPERATING THIS APPLIANCE.

This appliance is intended for use in commercial establishments by qualified operating personnel where all operators are familiar with the purpose, limitations, and associated hazards of this appliance. Operating instructions and warnings must be read and understood by all operators and users.

BEFORE INITIAL USE:

Interior oven surfaces must be heated to remove surface oils and the accompanying odor produced during the first use of the oven.

1. Wipe all wire shelves, side racks and the full oven interior with a clean, damp cloth.

ASC-2E • PRODUCT\PAN CAPACITY	
27 lb (12 kg) MAXIMUM — 17 qts (15 liters)	
Nine (9): 18" x 13" x 1" half-size sheet pans	
5 chrome plated wire shelves with 2 removable side racks and 9 shelf positions spaced at 1-5/8" (41mm)	

OPTIONS & ACCESSORIES • ASC-2E	
<input type="checkbox"/> CASTER KIT, 6" (152mm)	5013871
LEG KIT, 4" (102mm)	
<input type="checkbox"/> Seismic feet	5004688
LEG KIT	
<input type="checkbox"/> with Bullet feet, 19-1/2" (495mm) HEIGHT	5005169
<input type="checkbox"/> with Seismic feet, 19-1/2" (495mm) HEIGHT	5005168
<input type="checkbox"/> with Casters, 23" (584mm) HEIGHT	5005181
<input type="checkbox"/> SHELF, OVEN RACK	SH-26894
STACKING HARDWARE	
SEE INDIVIDUAL STACKING COMBINATION SPECIFICATION SHEETS	
STAND, SINGLE OVEN	
<input type="checkbox"/> with Bullet feet, 26-1/2" (673mm) HEIGHT	5004672
<input type="checkbox"/> with Seismic feet, 26-1/2" (673mm) HEIGHT	5005172
<input type="checkbox"/> with Casters, 30" (762mm) HEIGHT	5004687

IN THE EVENT OF A POWER FAILURE:

- TURN ALL SWITCHES OFF.
- WAIT UNTIL POWER IS RESTORED BEFORE ATTEMPTING TO OPERATE THE OVEN.

NOTE: *If such an event has occurred, it is strongly recommended that you ensure the food in the oven is safe for consumption according to local health regulations.*

2. Close the oven doors, press the power switch to the ON position, and set the thermostat to 300°F (149°C).
3. Allow the oven to cycle for approximately 2 hours or until no odor is detected.

PREHEATING:

Always preheat a cold oven for a minimum of 20 minutes before cooking product. Follow the operating instructions indicated on the next few pages of this manual.

ASC-4E • PRODUCT\PAN CAPACITY
72 lb (33 kg) maximum • 45 qts (43 liters)
Twelve (12): 18" x 26" x 1" full-size sheet pans
6 chrome plated wire shelves with 2 removable side racks and 12 shelf positions spaced at 1-3/4" (43mm)

OPTIONS & ACCESSORIES • ASC-4E	
<input type="checkbox"/> CASTER SET, 6" (152mm) FOR MOBILE STACK APPLICATIONS	5003790
<input type="checkbox"/> COOLING RACK FOR OVEN STAND	5003791
LEG SET (4)	
<input type="checkbox"/> 6" (152mm) with Bullet Feet	5003794
<input type="checkbox"/> 6" (6152mm) with Seismic Feet	5003795
<input type="checkbox"/> 25" (635mm) with Seismic Feet	5003785
<input type="checkbox"/> PANEL FOR BACK, Stainless Steel	5005876
SHELF, OVEN RACK	
<input type="checkbox"/> INTERCHANGEABLE WITH COOLING RACK	SH-26795
STACKING HARDWARE	
SEE INDIVIDUAL STACKING COMBINATION SPECIFICATION SHEETS	
STAND, STAINLESS STEEL	
<input type="checkbox"/> Mobile, with Cooling Racks & Casters, 38" H (965mm)	5003786
<input type="checkbox"/> Stationary, with Cooling Racks & Bullet Feet	5003489
<input type="checkbox"/> Stationary, with Cooling Racks & Seismic Feet	5003787
34-1/4" (870mm) min. • 35-1/2" (902mm) max. H (FEET ARE ADJUSTABLE)	

OPERATING INSTRUCTIONS

PAN/SHELF POSITIONS FOR ASC-2E:

The oven includes 5 chrome plated wire shelves with two removable side racks and 9 shelf positions spaced at 1-5/8" (41mm).

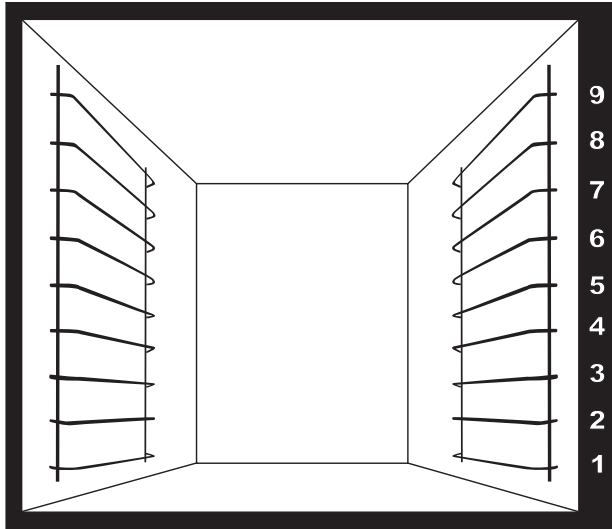

1. POSITION 2, 4, 6, 8 The best arrangement for broiling, baking cookies and for other baked goods under 2-1/2" (65mm) in height. This arrangement can also be used as the maximum capacity for reconstituting frozen entrées.
2. POSITION 1, 4, 7 General baking with the use of sheet pans for products under 3-1/2" (89mm) in height. Products include cakes, pies, muffins, or extended dishes in 12" x 20" x 2-1/2" deep pans (530mm x 325mm x 65mm GN 1/1).
3. POSITION 1, 5 Ideal positions for baking bread, meringue, or extended dishes and roasts in pans not to exceed 5-1/2" (140mm) in height.
4. POSITION 1, 6 Arrangement necessary for roasting whole turkey or roasts up to 7" (178mm) in height.

PAN/SHELF POSITIONS FOR ASC-4E:

The oven includes 6 chrome plated wire shelves with two removable side racks and 12 shelf positions spaced at 1-3/4" (43mm).

1. POSITION 2, 4, 6, 8, 12 The best arrangement for broiling, baking cookies and for other baked goods under 2-1/2" (65mm) in height. This arrangement can also be used as the maximum capacity for reconstituting frozen entrées.
2. POSITION 1, 4, 7, 10 General baking with the use of sheet pans for products under 3-1/2" (89mm) in height. Products include cakes, pies, muffins, or extended dishes in 12" x 20" x 2-1/2" deep pans (530mm x 325mm x 65mm GN 1/1).
3. POSITION 1, 5, 9 Ideal positions for baking bread, meringue, or extended dishes and roasts in pans not to exceed 5-1/2" (140mm) in height.
4. POSITION 1, 6 Arrangement necessary for roasting whole turkey or roasts up to 7" (178mm) in height.

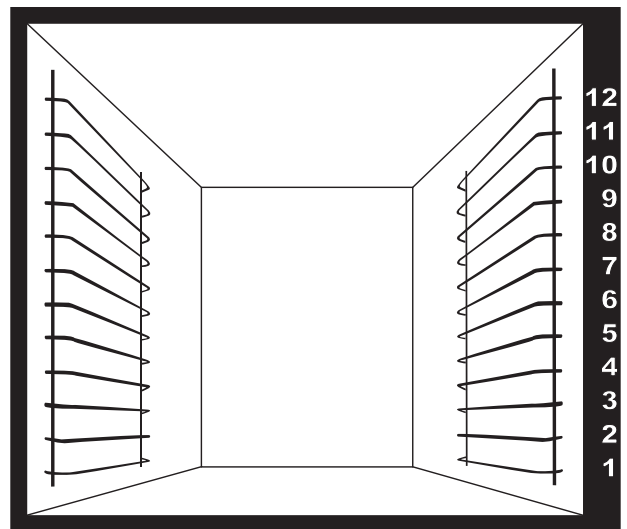

CAUTION



METAL PARTS OF THIS EQUIPMENT BECOME EXTREMELY HOT WHEN IN OPERATION. TO AVOID BURNS, ALWAYS USE HAND PROTECTION WHEN OPERATING THIS APPLIANCE.

OPERATING INSTRUCTIONS

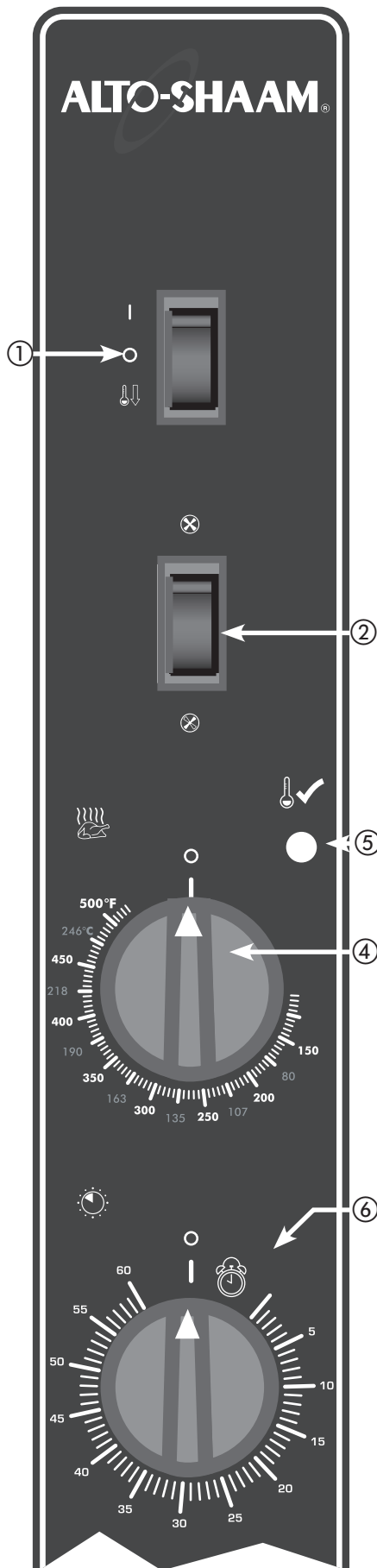

MANUAL CONTROL OPERATION

1. Press POWER SWITCH **1** to the *ON* position.
2. Press FAN SWITCH **2** to *high* or *low* fan speed.
3. Set COOK TEMPERATURE THERMOSTAT **4** to the temperature desired.

When this temperature is reached, LIGHT OFF\OVEN READY indicator light **5** will go out.

ALLOW A MINIMUM OF 20 MINUTES TO PREHEAT A COLD OVEN.

4. Load product into the oven.

For best results, always load the oven from the bottom to the top position and load as quickly as possible to retain maximum oven compartment heat.

5. Set COOK TIMER **6** by rotating the knob clockwise past the time required and then back to the desired time.

The timer will begin to count down. When the timer reaches zero, the oven will produce an audible alert signal that will continue for three minutes or until the timer knob is turned counterclockwise to the *OFF* position.

COOL-DOWN MODE

1. Press POWER SWITCH **1** to the *COOL DOWN* position.
2. Open the oven doors.

SHUT-DOWN PROCEDURE

1. Press POWER SWITCH **1** to the *OFF* position.

CHEF OPERATING TIPS

The Alto-Shaam convection oven will provide the best results and longest possible service with the utilization of the following suggestions and guidelines.

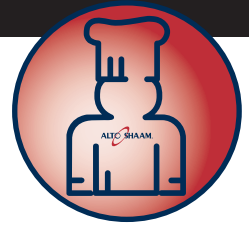

NOTE: Moisture will escape around the doors when baking products with a heavy moisture content such as chicken, potatoes, etc. This is a normal operating condition.

1. Thoroughly preheat the oven for approximately 20 minutes before use.
2. As a general rule, the cooking temperature can be set lower than the temperature used in a conventional oven. Cooking time may also be shorter. It is suggested the first batch of each product prepared be monitored closely to check for variances.
3. Maintain a record of the temperatures, times, and load capacities established for products cooked on a regular basis since they will be the same or similar for succeeding loads.
4. When practical, start cooking the lowest temperature products first and gradually work up to products with a higher cooking temperature.
5. If the cooking temperature setting for the previous product is more than 10°F (5°C to 6°C) higher than the temperature needed for the next load, use the FAN COOL-DOWN feature to decrease the oven temperature before setting the oven to a lower temperature.
6. Work as quickly as possible when loading the oven to prevent heat loss.
7. When the audible signal indicates the time has expired, remove the food product from the oven as quickly as possible to avoid over cooking.
8. Pans should be centered between side racks and each shelf should be loaded evenly to allow proper air circulation within the oven compartment.
9. To assure even cooking when baking, weigh or measure the product in each pan.
10. **ASC-2E:** When cooking five pans of product, start from the bottom of the oven and use side rack positions 1, 3, 5, 7, and 9.
ASC-4E: When cooking six pans of product, start from the bottom of the oven and use side rack positions 2, 4, 6, 8, 10, and 12.
11. Do not overload the oven. Refer to product/pan capacities indicated in this manual.
12. To obtain an evenly baked product, muffin pans should be placed in the oven with the short side of each pan facing the front of the oven.
13. When rethermalizing frozen casseroles, preheat the oven 100°F (38°C) over the suggested temperature to compensate for the introduction of a large quantity of frozen product into the oven compartment. Reset the thermostat to the correct cooking temperature after the oven is loaded.
14. Use a pan extender or two inch (51mm) deep, 18" x 26" pans for batter-type products that weigh more than 8 pounds (3 to 4 kg), i.e.; pineapple upside-down cake.
15. To avoid obstructing airflow that would result in uneven cooking, never place anything directly on the bottom of the oven cavity.

Cooking Guidelines

Food	Temperature		Time (Minutes)	Food	Temperature		Time (Minutes)
	°F	°C			°F	°C	
Cakes, Sheet	325°F	163°C	25	Macaroni & Cheese (frozen, full oven)	350°F	177°C	90
Chicken pieces (30 breasts & thighs, 25 legs & wings)	400°F	204°C	25	Macaroni & Cheese (refrigerated)	350°F	177°C	30
Chicken halves	400°F	204°C	40	Muffins	325°F	163°C	13-15
Beef patties	400°F	204°C	8	Pies, Frozen	325°F	163°C	40
Bacon	350°F	177°C	16	Pizzas, Individual	325°F	163°C	15
Fish, frozen (5 oz.)	350°F	177°C	15	Potatoes, Baked	350°F	177°C	50
Macaroni & Cheese (frozen, 1 pan)	350°F	177°C	50	Sandwiches, Grilled Cheese	400°F	204°C	4-6
				Tater tots	450°F	232°C	10

**AT THE END OF THE DAY,
UTILIZE THE COOL-DOWN MODE
AND OPEN THE OVEN DOORS.**

**Do not place anything directly
on the bottom of the oven cavity.**

CARE AND CLEANING

CLEANING AND PREVENTATIVE MAINTENANCE

PROTECTING STAINLESS STEEL SURFACES



It is important to guard against corrosion in the care of stainless steel surfaces. Harsh, corrosive, or inappropriate chemicals can completely destroy the protective surface layer of stainless steel. Abrasive

pads, steel wool, or metal implements will abrade surfaces causing damage to this protective coating and will eventually result in areas of corrosion. Even water, particularly hard water that contains high to moderate concentrations of chloride, will cause oxidation and pitting that result in rust and corrosion. In addition, many acidic foods spilled and left to remain on metal surfaces are contributing factors that will corrode surfaces.

Proper cleaning agents, materials, and methods are vital to maintaining the appearance and life of this appliance. Spilled foods should be removed and the area wiped as soon as possible but at the very least, a minimum of once a day. Always thoroughly rinse surfaces after using a cleaning agent and wipe standing water as quickly as possible after rinsing.

CLEANING AGENTS

Use non-abrasive cleaning products designed for use on stainless steel surfaces. Cleaning agents must be chloride-free compounds and must not contain quaternary salts. Never use hydrochloric acid (muriatic acid) on stainless steel surfaces. Always use the proper cleaning agent at the manufacturer's recommended strength. Contact your local cleaning supplier for product recommendations.

CLEANING MATERIALS

The cleaning function can usually be accomplished with the proper cleaning agent and a soft, clean cloth. When more aggressive methods must be employed, use a non-abrasive scouring pad on difficult areas and make certain to scrub with the visible grain of surface metal to avoid surface scratches. Never use wire brushes, metal scouring pads, or scrapers to remove food residue.

 CAUTION	
 NO SCRAPERS	TO PROTECT STAINLESS STEEL SURFACES, COMPLETELY AVOID THE USE OF ABRASIVE CLEANING COMPOUNDS, CHLORIDE BASED CLEANERS, OR CLEANERS CONTAINING QUATERNARY SALTS. NEVER USE HYDROCHLORIC ACID (MURIATIC ACID) ON STAINLESS STEEL. NEVER USE WIRE BRUSHES, METAL SCOURING PADS OR SCRAPERS.
 NO WIRE BRUSHES	
 NO STEEL PADS	

CARE AND CLEANING



The oven is fabricated with an easy to clean porcelain enamel interior or an optional stainless steel interior.

NOTE: Always allow the oven to cool before cleaning. If the oven is hot, allow the interior surfaces to become cool to the touch by opening the oven doors and engaging the cool-down function.

DO NOT USE ABRASIVE CLEANING COMPOUNDS.

Completely avoid the use of abrasive cleaning compounds, chloride-based cleaners, or cleaners containing quaternary salts. To protect metal finish on stainless steel, never use hydrochloric acid (muriatic acid).

⚠ DANGER	
	DISCONNECT UNIT FROM POWER SOURCE BEFORE CLEANING OR SERVICING.

DANGER	
	AT NO TIME SHOULD THE INTERIOR OR EXTERIOR BE STEAM CLEANED, HOSED DOWN, OR FLOODED WITH WATER OR LIQUID SOLUTION OF ANY KIND. DO NOT USE WATER JET TO CLEAN.
	SEVERE DAMAGE OR ELECTRICAL HAZARD COULD RESULT.
	WARRANTY BECOMES VOID IF APPLIANCE IS FLOODED

CLEAN THE OVEN ON A DAILY BASIS

1. After the oven has cooled, remove all detachable items such as wire shelves, side racks, and drip pan. Clean these items separately.
2. Remove any food scraps from shelves, shelf supports, and blower fan wheel. Convection baffle openings must be kept clear of food scraps and grease.
3. Wipe the interior metal surfaces of the oven with a paper towel to remove any remaining food debris.
4. Clean interior with a damp cloth or sponge and any good commercial detergent at the recommended strength.
5. For baked-on food deposits, use a non-caustic and non-toxic commercial oven cleaner appropriate for the interior oven surface of your oven. Follow the product manufacturer's instructions carefully for the use of this product. Any commercial oven cleaner must be approved for use on food contact areas. Remove soil with the use of a plastic scouring pad.

6. Wipe door gaskets thoroughly since these areas harbor food debris and grease.
7. Rinse surfaces by wiping with a clean cloth or sponge and clean warm water.
8. Remove excess water with a sponge and wipe dry with a clean cloth or air dry. Leave doors open until interior is completely dry. Replace side racks and shelves.



Always follow appropriate state or local health (hygiene) regulations regarding all applicable cleaning and sanitation requirements for food service equipment.

**AT THE END OF THE DAY,
UTILIZE THE COOL-DOWN MODE
AND OPEN THE OVEN DOORS.**

CARE AND CLEANING

EXTERIOR:

To help maintain the protective film coating on polished stainless steel, clean the exterior of the cabinet with a cleaner recommended for stainless steel surfaces. Spray the cleaning agent on a clean cloth and wipe with the grain of the stainless steel.

Wipe control panel, door vents and door handles, thoroughly since these areas harbor food debris.

Clean exterior glass surfaces with a commercial window cleaner.

DO NOT USE ABRASIVE CLEANING COMPOUNDS.

MOTOR CARE

The convection oven motor contains self-lubricating, sealed ball bearings and is generally maintenance-free. During operation, the interior of the motor is cooled by air flowing into the rear of the motor case. This is a general operating feature when proper clearances have been allowed.

**AT THE END OF THE DAY,
UTILIZE THE COOL-DOWN MODE
AND OPEN THE OVEN DOORS.**

SERVICE

TROUBLESHOOTING GUIDE

TROUBLE	POSSIBLE CAUSE	REMEDY
Oven has no power	<ul style="list-style-type: none"> • Insufficient power supply • Defective power cord or plug • Defective power switch. • Loose electrical connection 	<ul style="list-style-type: none"> • Check power source. • Check and replace if necessary. • Check and replace if necessary. • Check all electrical connections
Cook temperature too high/low	<ul style="list-style-type: none"> • Thermostat out of calibration • Defective thermostat 	<ul style="list-style-type: none"> • Check Calibration using a digital thermometer in the center of the cavity. Calibrate if necessary • Replace thermostat
Cook temperature too low	<ul style="list-style-type: none"> • Defective door gasket • Door not closing properly 	<ul style="list-style-type: none"> • Replace Gasket • Check latches on the top and bottom of door.
Fan not running	<ul style="list-style-type: none"> • Door switch defective or out of adjustment • Motor switch tripped (2E only) • Door not closing properly 	<ul style="list-style-type: none"> • Adjust or replace • Reset, Black button should be pushed in • Check latches on the top and bottom of door.
Fan running but no heat	<ul style="list-style-type: none"> • High limit tripped • Defective element 	<ul style="list-style-type: none"> • Reset high limit and test temperatures • Replace element
Fan runs with door open	<ul style="list-style-type: none"> • Door switch defective or out of adjustment 	<ul style="list-style-type: none"> • Adjust or replace



FULL ASSEMBLY - ASC-2E

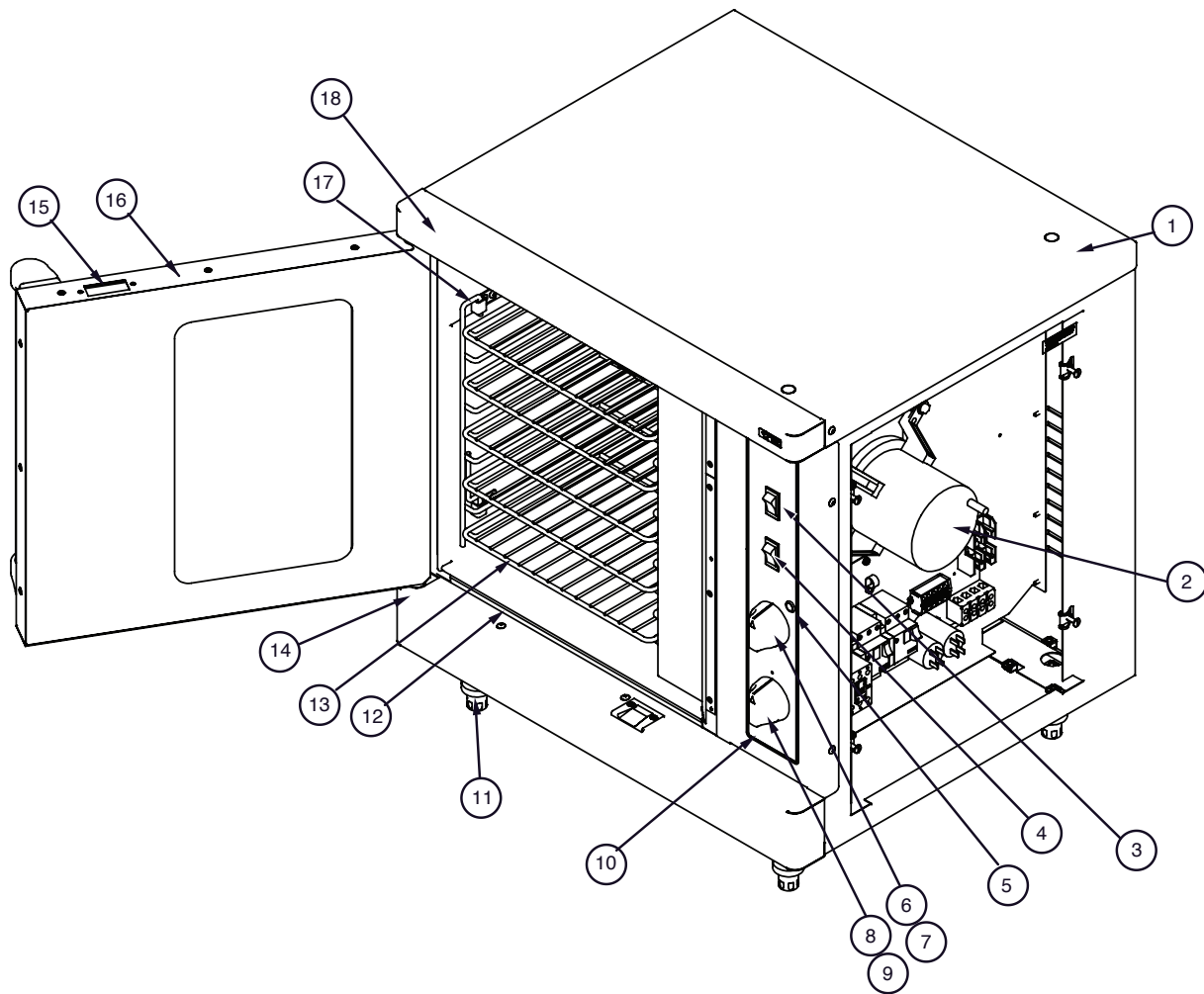

ITEM	DESCRIPTION	PART NO.	QTY	ITEM	DESCRIPTION	PART NO.	QTY
1	PANEL, TOP AND SIDE	1005455	1	11	FEET	SEE PG 10	4
2	MOTOR	MO-34208	1	12	GASKET	TOP/BOTTOM	1005316
3	SWITCH, ON/OFF/COOL DOWN	SW-34112	1			SIDE	1005311
4	SWITCH, FAN HI/LOW	SW-34101	1	13	OVEN RACK		SH-26894
5	INDICATOR LIGHT	LI-3951	1	14	COVER, BOTTOM HINGE		1005458
6	KNOB, THERMOSTAT	KN-34297	1	15	LATCH		LT-26976
7	THERMOSTAT	TT-34092*	1	16	DOOR ASSEMBLY		DR-27848
8	KNOB, TIMER	KN-34858	1	17	SIDE RACK		SR-26893
9	TIMER	TR-34724*	1	18	COVER, TOP HINGE		1005459
10	PANEL OVERLAY	PE-26977	1				

*Not Shown

Part numbers and drawings are subject to change without notice.

SERVICE

CONTROL ASSEMBLY - ASC-2E

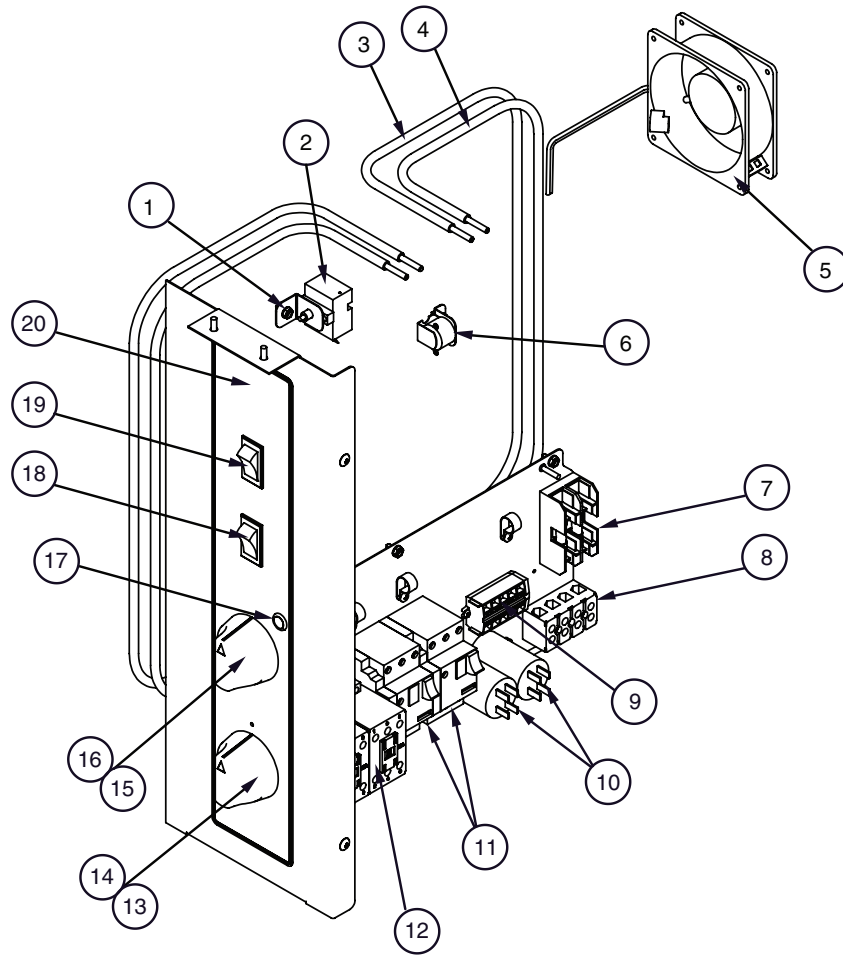

ITEM	DESCRIPTION	PART NO.	QTY	ITEM	DESCRIPTION	PART NO.	QTY
1	HIGH LIMIT BRACKET	1012678	1	11	SWITCH, MOTOR PROTECT	SW-33500	1
2	SAFETY, 340°C	TT-3750	1	12	CONTACTOR	CN-3731	1
3	HEAT ELEMENTS, OUTER	208V EL-34211	1	13	KNOB, TIMER	KN-34858	1
		240V EL-34210	1	14*	TIMER	TR-34724	1
4	HEAT ELEMENTS, INNER	208V EL-34212	1	15	KNOB, THERMOSTAT	KN-34297	1
		240V EL-34209	1	16*	THERMOSTAT	TT-34092	1
5	FAN, BOX	70CFM, 230V, 50-60Hz FA-3568	1	17	INDICATOR LIGHT	LI-3951	1
6	BUZZER	BZ-34113	1	18	SWITCH, FAN HI/LOW	SW-34101	1
7	FUSE HOLDER	FU-3772	1	19	SWITCH, ON/OFF/COOL DOWN	SW-34112	1
8	BLOCK, TERMINAL	BK-3597	1	20	PANEL OVERLAY	PE-26977	1
9	BLOCK, MODULAR	BK-25567	1	21	FUSE, 15 AMP	FU-3775	2
10	10 UF CAPACITOR	CU-34432	2				

*Not Shown

Part numbers and drawings are subject to change without notice.

INTERIOR ASSEMBLY - ASC-2E

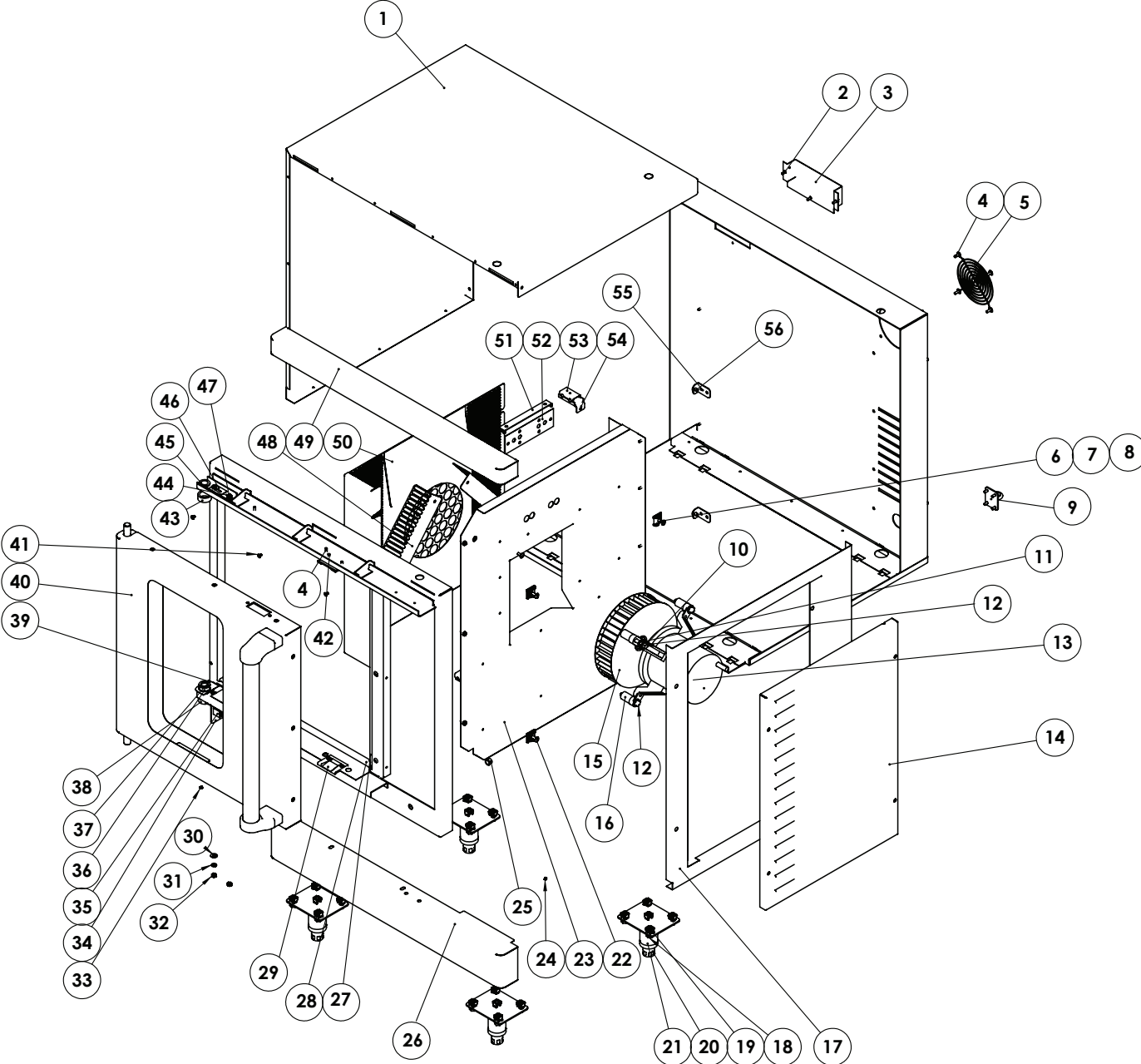

Part numbers and drawings are subject to change without notice.

SERVICE

INTERIOR ASSEMBLY - ASC-2E

ITEM	DESCRIPTION	PART NO.	QTY	ITEM	DESCRIPTION	PART NO.	QTY
1	BODY SIDE, TOP	1005455	1	29	DOOR LATCH ASC-2	LT-26976	2
2	SCREW, #10 X 1/2 SMS HEX HEAD SLOTTED	SC-26520	25	30	WASHER, 1/4", FLAT, 5/8 OD 18-8	WS-22094	4
3	VENT RISER, DOUBLE STACK	1005465	1	31	LOCK WASHER 1/4"	WS-2294	4
4	SCREW, 10-32 X1/2,NF PHIL TRUSS M/S,18-8	SC-2661	19	32	NUT, 1/4-20 NYLON INSERT 18-8	NU-23984	4
5	FAN GUARD	GD-2396	1	33	SCREW, SET #10-32 X .25 LG	SC-27433	1
6	STUD,CT M6 X 27 MM, 1/4 TURN	ST-22193	4	34	BRACKET, DOOR SWITCH	1005488	1
7	SPRINGS, M6 X 48 MM, SAFETY	SD-22194		35	SWITCH, DOOR	SW-34164	1
8	WASHERS, SAFETY, STEEL	WS-22195		36	SPACER, DOOR	SP-26442	1
9	BRACKET, TETHER	BT-26884	1	37	SPACER, DOOR	1005449	1
10	SCREW, 5/16-18 X 2" HEX HEAD	SC-22423	4	38	HINGE, DOOR CAM SWITCH	HG-27334	1
11	WASHER, 5/16" SPLIT LOCK	WS-2867	4	39	COVER, BEARING	1006397	1
12	WASHER, 5/16 FLAT	WS-23725	4	40	DOOR ASSEMBLY	DR-27848	1
13	MOTOR, 1/4HP,1725/1140RPM	MO-34208	1	41	10-32 U/C FHMS, 18-8, PH	SC-25004	4
14	DOOR PANEL, LOUVER, RH	1006602	1	42	SCREW, #10 X 1/2 SMS HEX HEAD SLOTTED	SC-23670	25
15	WHEEL, BLOWER	WH-26895	1	43	SPACER	SP-27997	1
16	SPACER, MOTOR	SP-26975	4	44	HINGE, PLATE TOP UNIVERSAL	1005423	2
17	PANEL, SIDE, RH	1005463	1	45	BUSHING, .63 X .63	BU-26433	2
18	SCREW, 5/16-18 X 5/8 SERR. HEX HD	SC-2351	16	46	PLATE, BUSHING	1006092	1
19	NUT, 5/16-18 CLIP	NU-26836	21	47	SCREW, 1/4-20 FHSC X .75	SC-26587	4
20	FOOT, INSERT ADJUSTMENT	FE-26125	4	48	DIFFUSER, AIR	1006396	2
21	LEG	LG-26123	4	49	COVER, TOP	1005459	1
22	CLIP, HOLDING, M6	CL-22196	4	50	BAFFLE ASSEMBLY	5005074	1
23	COVER, INSULATION	1005461	1	51	BRACKET, THERMOSTAT	1005478	1
24	RIVET, #42 STAINLESS	RI-2097	8	52	COVER, ELEMENT	1005460	1
25	BUSHING, 1/2" HOLE	BU-3006	1	53	RETAINER, ELEMENT	1005477	4
26	COVER, BOTTOM	1005458	1	54	BRACKET, MTG ELEMENT	1005349	4
27	GASKET, OVEN L/R	1005311	2	55	BRACKET, MTG BAFFLE	1005310	2
28	GASKET, OVEN TOP/BOTTOM	1005316	2	56	STUD, SHOULDER, SHORT	ST-2546	3

Part numbers and drawings are subject to change without notice.

FULL ASSEMBLY - ASC-4E

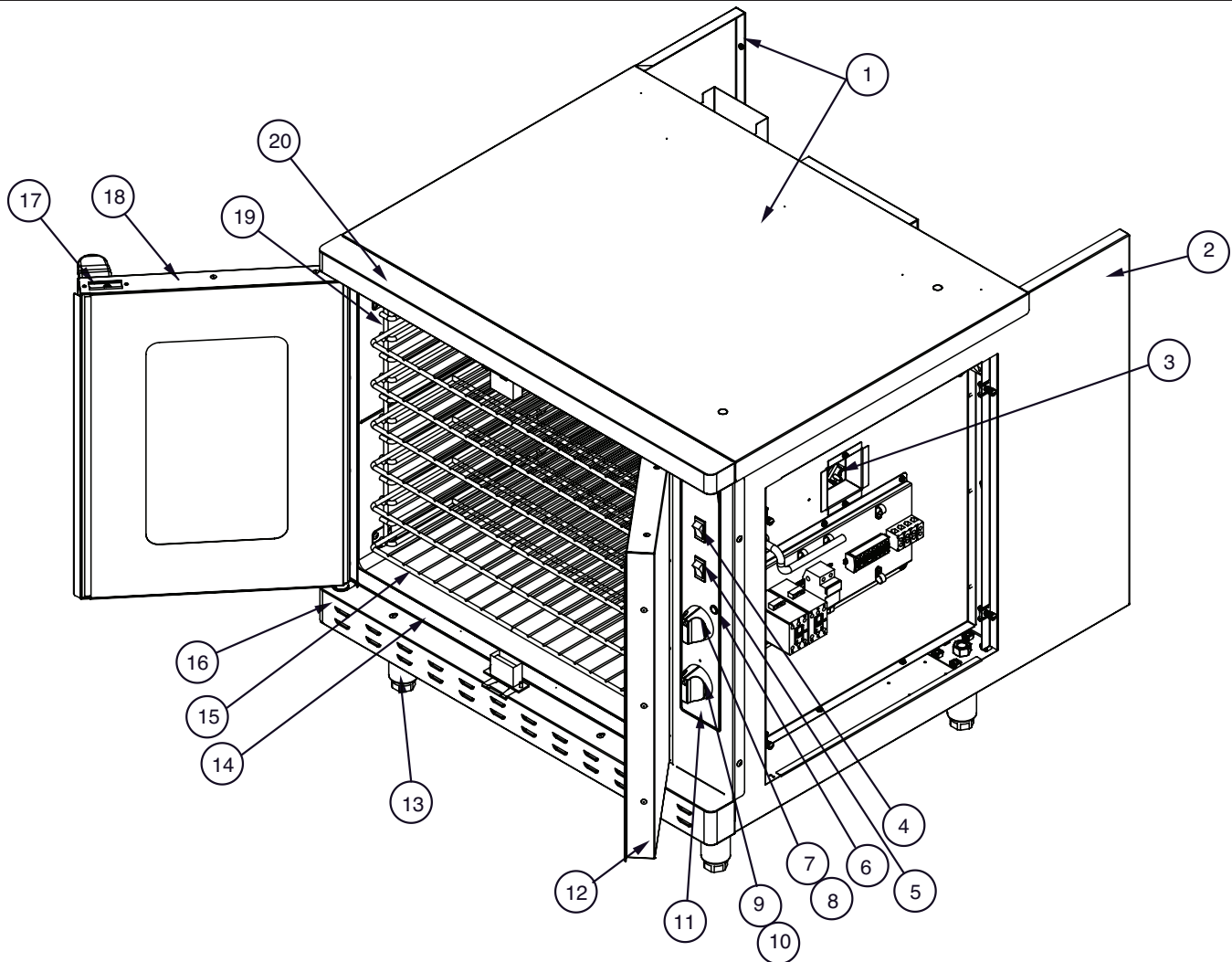

ITEM	DESCRIPTION	PART NO.	QTY	ITEM	DESCRIPTION	PART NO.	QTY
1	PANEL OUTER, TOP AND LH	1006623	1	12	DOOR ASSEMBLY, RH	DR-27849	1
2	PANEL OUTER, RH	1006671	1	13	FEET	SEE PG 10	4
3	HIGH LIMIT	SW-34150	1	14	GASKET	TOP/BOTTOM	1006606
4	SWITCH, ON/OFF COOL-DOWN	SW-34112	1			SIDE	1000605
5	SWITCH, FAN, HI/LO	SW-34101	1	15	OVEN RACK		SH-26795
6	INDICATOR LIGHT	LI-3951	1	16	COVER, BOTTOM HINGE		1006679
7*	THERMOSTAT	TT-34092	1	17	LATCH		LT-26976
8	KNOB, THERMOSTAT	KN-34297	1	18	DOOR ASSEMBLY, LH		DR-27850
9*	TIMER	208-240V TR-34724	1	19	SIDE RACK		SR-26396
		440-480V TR-34174	1	20	COVER, TOP HINGE		1006678
10	KNOB, TIMER	KN-34858	1	21*	PANEL, LOUVERED ACCESS		1006672
11	PANEL OVERLAY	PE-26978	1				

*Not Shown

Part numbers and drawings are subject to change without notice.

SERVICE

CONTROL ASSEMBLY - ASC-4E

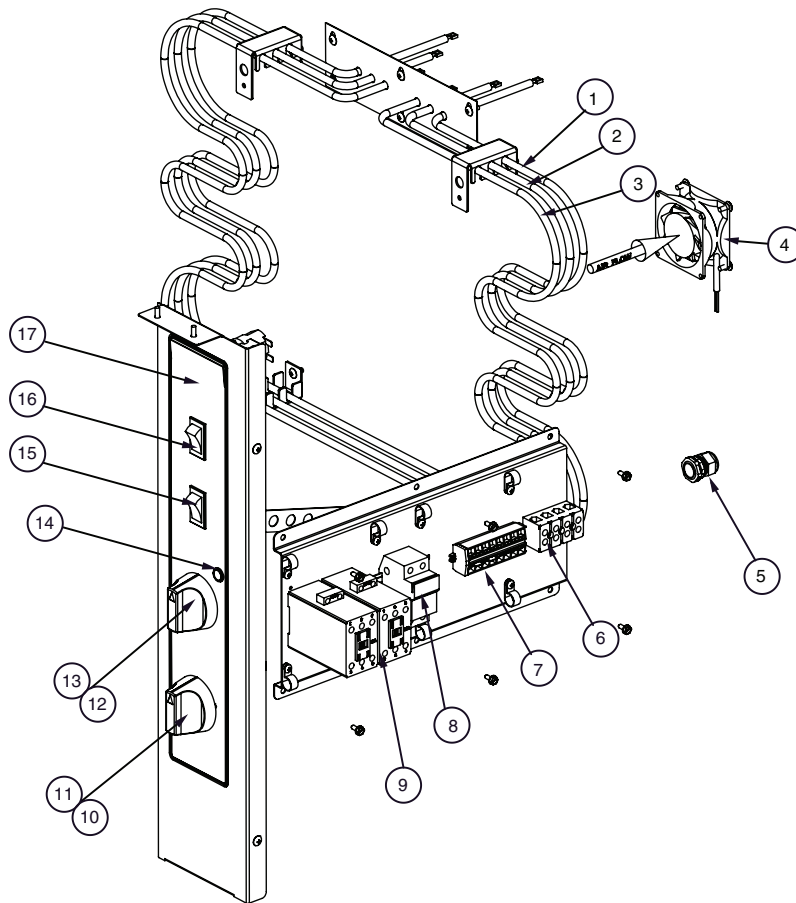

ITEM	DESCRIPTION	PART NO.	QTY	ITEM	DESCRIPTION	PART NO.	QTY		
1	HEAT ELEMENTS, REAR	208V EL-34128	1	8	FUSE HOLDER	FU-34771	1		
		240V EL-34125	1			9	CONTACTOR	CN-3731	1
		480V EL-34345	1					10	KNOB, TIMER
2	HEAT ELEMENTS, MIDDLE	208V EL-34127	1	11*	TIMER	208-240V TR-34724	1		
		240V EL-34146	1			440-480V TR-34174	1		
		480V EL-34346	1	12	KNOB, THERMOSTAT	KN-34297	1		
3	HEAT ELEMENTS, FRONT	208V EL-34126	1			13*	THERMOSTAT	TT-34092	1
		240V EL-34129	1					14	INDICATOR LIGHT
		480V EL-34347	1	15	SWITCH, FAN, HI/LO				
4	FAN, BOX	35CFM, 230V, 50-60Hz	1			16	SWITCH, ON/OFF COOL-DOWN	SW-34112	1
5	BUSHING, STRAIGHT, STRAIN RELIEF	BU-3964	1	17	PANEL OVERLAY			PE-26977	1
6	BLOCK, TERMINAL	BK-3597	1			18*	FUSE, 15 AMP	FU-34772	2
7	BLOCK, MODULAR	BK-34684	1						

*Not Shown

Part numbers and drawings are subject to change without notice.

INTERIOR ASSEMBLY - ASC-4E

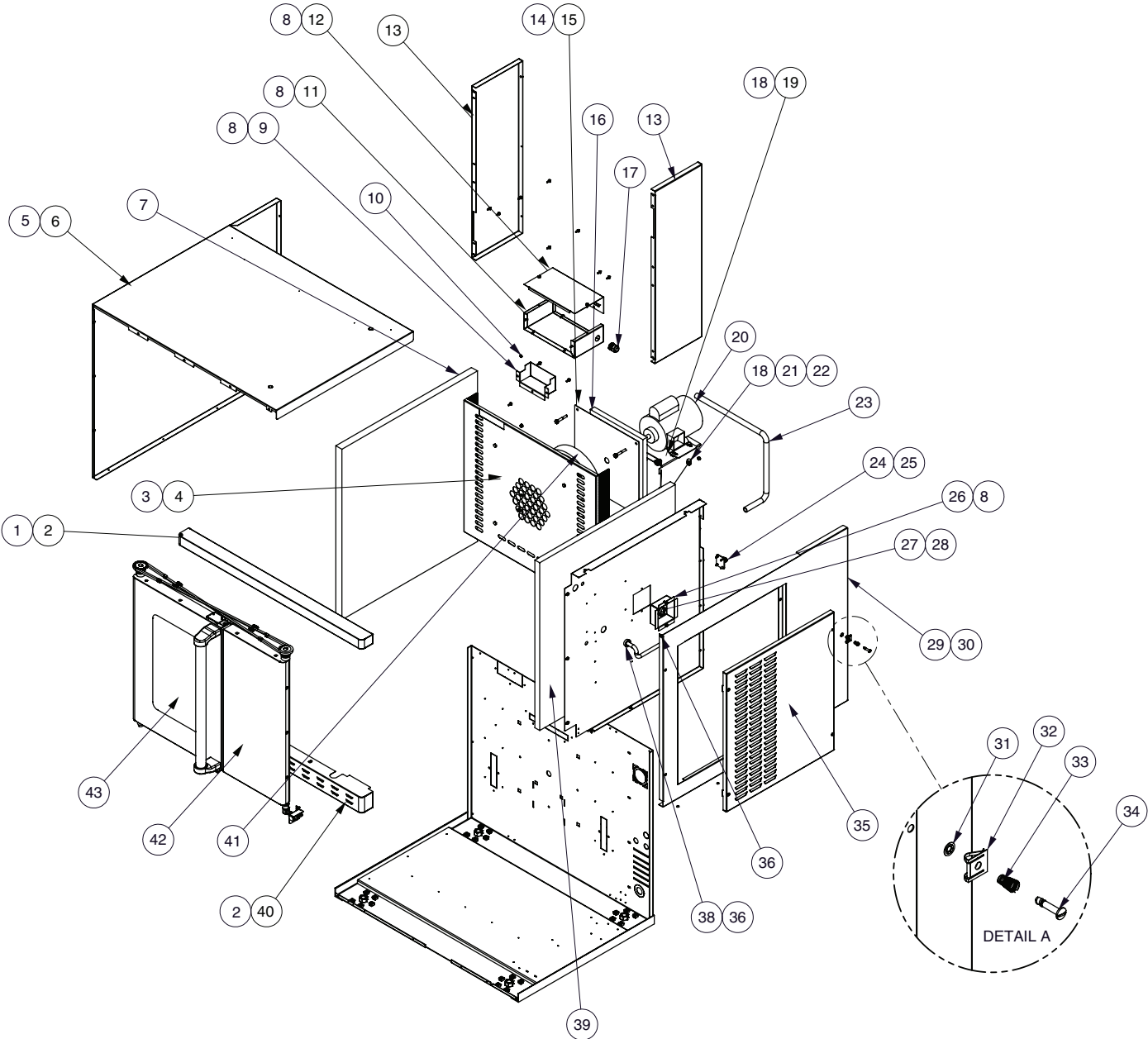

Part numbers and drawings are subject to change without notice.

SERVICE

INTERIOR ASSEMBLY - ASC-4E

ITEM	DESCRIPTION	PART NO.	QTY
1	COVER, TOP HINGE	1006679	1
2	SCREW,10-32 X1/2,NF PHIL TRUSS M/S,18-8	SC-2661	4
3	SCREW, 1/4-20 X 1/2" HEX HEAD	SC-22729	4
4	BAFFLE ASSEMBLY	5005222	1
5	RIVET, BLIND, #44, STAINLESS	RI-2100	7
6	BODY, SIDE / TOP	1006623	1
7	INSULATION, 1-1/2" THICK 28" X 30.5"	IN-27867	1
8	SCREW, #10 X 1/2 SMS HEX HEAD SLOTTED	SC-26520	40
9	MOISTURE VENT COVER	1004599	1
10	NUT, 10-32, NF HEX MS, #18-8	NU-2215	6
11	ELEMENT BOX BOTTOM	1004612	1
12	ELEMENT BOX TOP	1004606	1
13	BRACKET, BACK STIFFENER	1007068	2
14	SCREW, 5/16-18 X 2" HEX HEAD	SC-22423	4
15	MOTOR CAVITY PLATE	1011111	1
16	INSULATION, 1" THICK 10.875" X 10.875"	IN-27866	1
17	BUSHING, STRAIGHT, STRAIN RELIEF	BU-34606	2
18	SCREW, 5/16-18 X 5/8" HEX CAP	SC-2900	6
19	MOTOR MOUNT	1009810	1
20	CONVECTION MOTOR	115V MO-34790	1
	CONVECTION MOTOR ASSEMBLY	125V 5010354*	1
21	WASHER, LOCK, 5/16 DIA.	WS-2867	6
22	NUT, HEX, 5/16-18	NU-2866	4
23	TUBE, FLEXIBLE CONDUIT 3FT	TU-33178	1
24	BRACKET, TETHER	BT-26884	1
25	SCREW, 10-32X1/2, NF PHIL, FLAT	SC-23670	4
26	BOX ASSEMBLY, HIGH LIMIT	5003658	1
27	SWITCH, HIGH LIMIT	SW-34150	1
28	SCREW 10-32 X 1/4" PAN HEAD	SC-26791	8
29	PANEL, RH SIDE	1006671	1
30	RIVET, #42 STAINLESS	RI-2097	6
31	WASHER, SAFETY, STEEL	WS-22195	4
32	CLIP, HOLDING, M6	CL-22196	4
33	SPRING, M6 X 48, SAFTY	SD-22194	4
34	STUD, M6 X 27 MM, 1/4 TURN	ST-22193	4
35	PANEL, ACCESS, LOUVERED	1006672	1
36	RIVET, 5/32 DOME	RI-26827	1
37	TUBING, CONDUIT 3/8" X 30" LONG	TU-22256	1
38	BUSHING, 1" HOLE	BU-33619	1
39	INSULATION 1" THICK 28" X 30"	IN-27866	1
40	COVER, BOTTOM HINGE	1006678	1
41	WHEEL, BLOWER ELECTRIC	WH-26405	1
42	DOOR, RH	DR-27849	1
43	DOOR, LH	DR-27850	1

*Prior to serial number 870689

Part numbers and drawings are subject to change without notice.

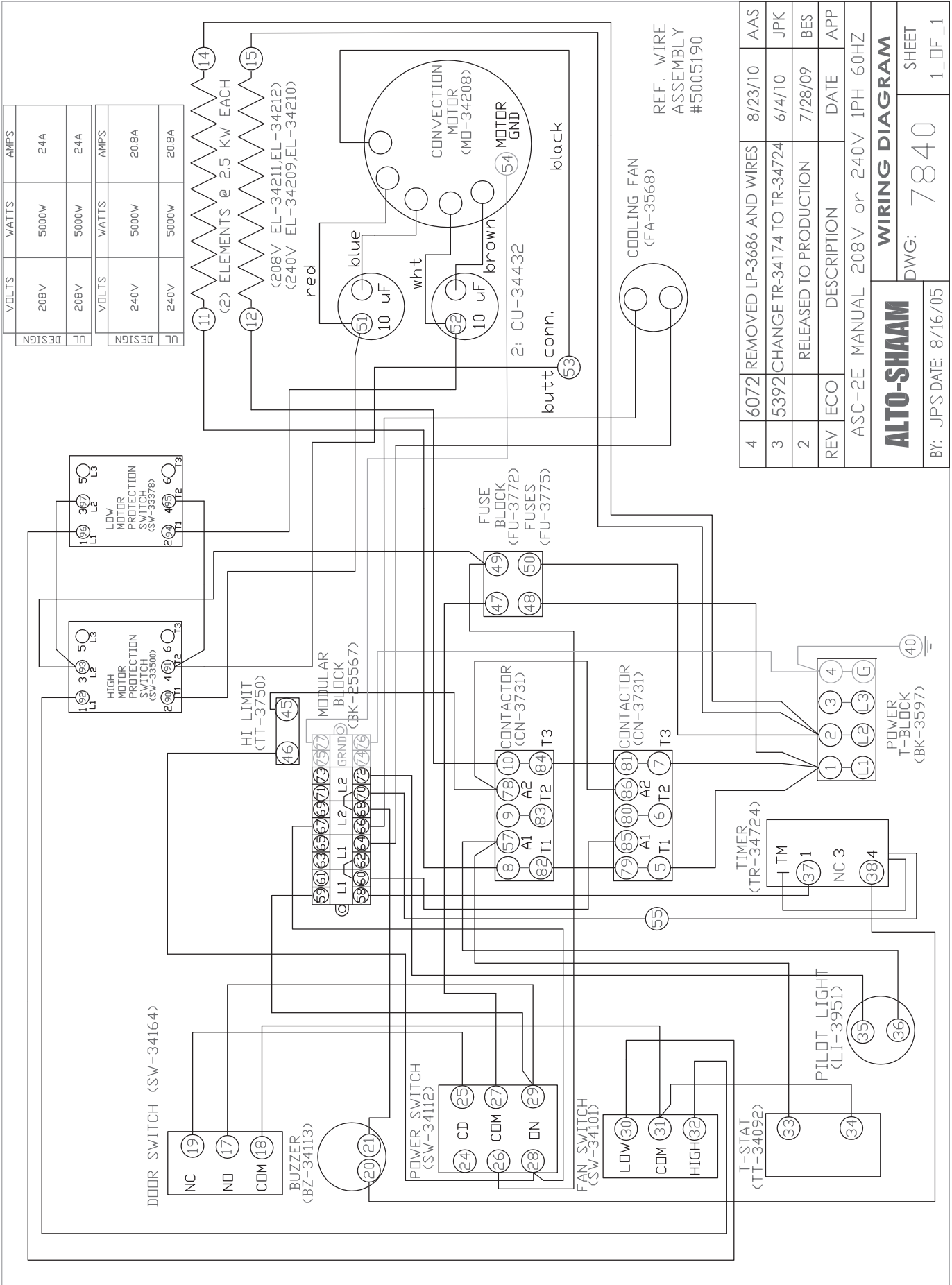

VOLTS	WATTS	AMPS
208V	5000W	24A
208V	5000W	24A

VOLTS	WATTS	AMPS
240V	5000W	20.8A
240V	5000W	20.8A

(2) ELEMENTS @ 2.5 KW EACH
 (208V EL-34211, EL-34212)
 (240V EL-34209, EL-34210)

REF. WIRE ASSEMBLY #5005190

REV	ECO	DESCRIPTION	DATE	APP
4	6072	REMOVED LP-3686 AND WIRES	8/23/10	AAS
3	5392	CHANGE TR-34174 TO TR-34724	6/4/10	JPK
2		RELEASED TO PRODUCTION	7/28/09	BES

ASC-2E MANUAL 208V or 240V 1PH 60HZ		
ALTO-SHAM		
DWG: 7840		SHEET
BY: JPS DATE: 8/16/05		1_OF_1

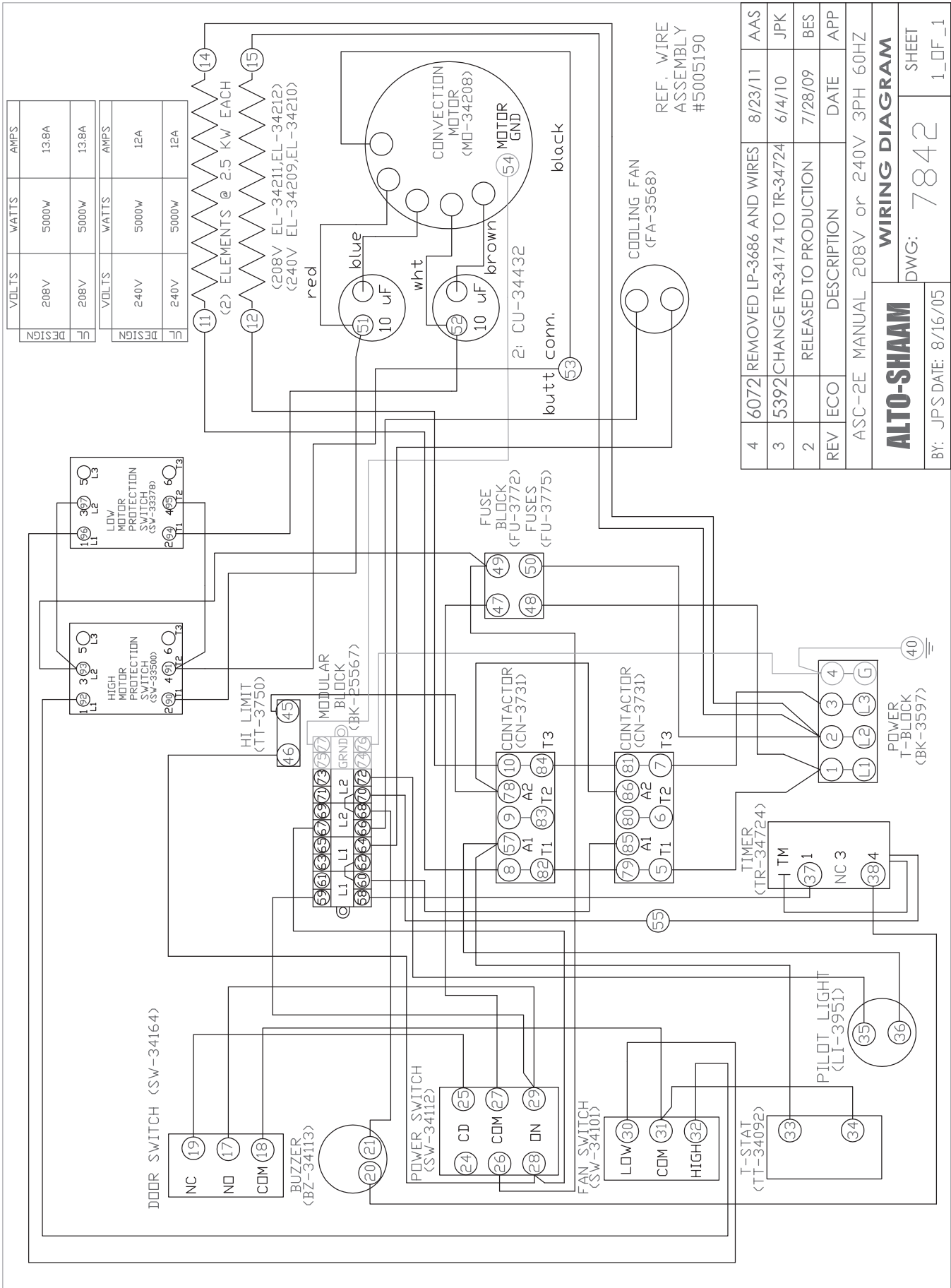

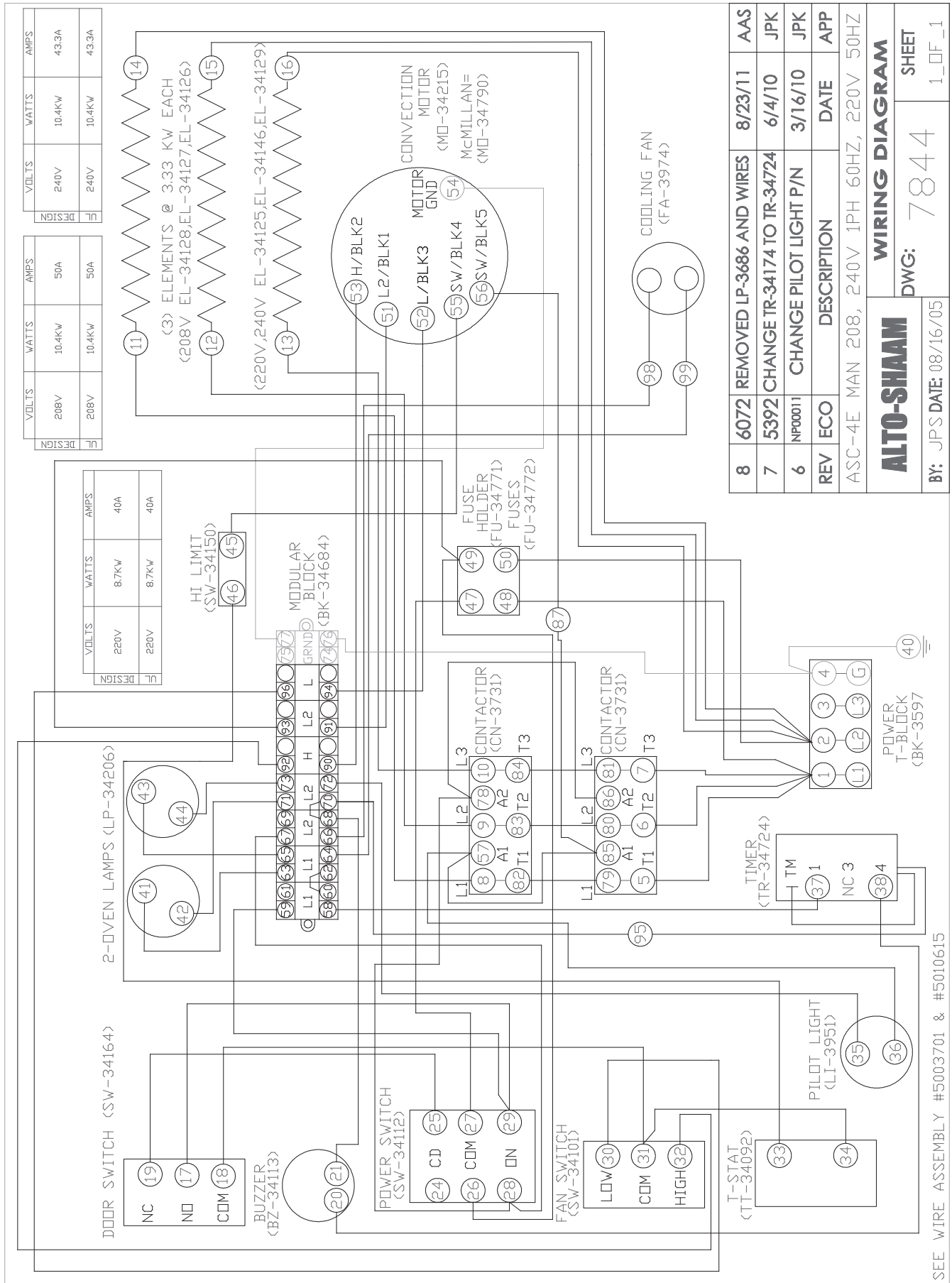

SEE WIRE ASSEMBLY #5003701 & #5010615

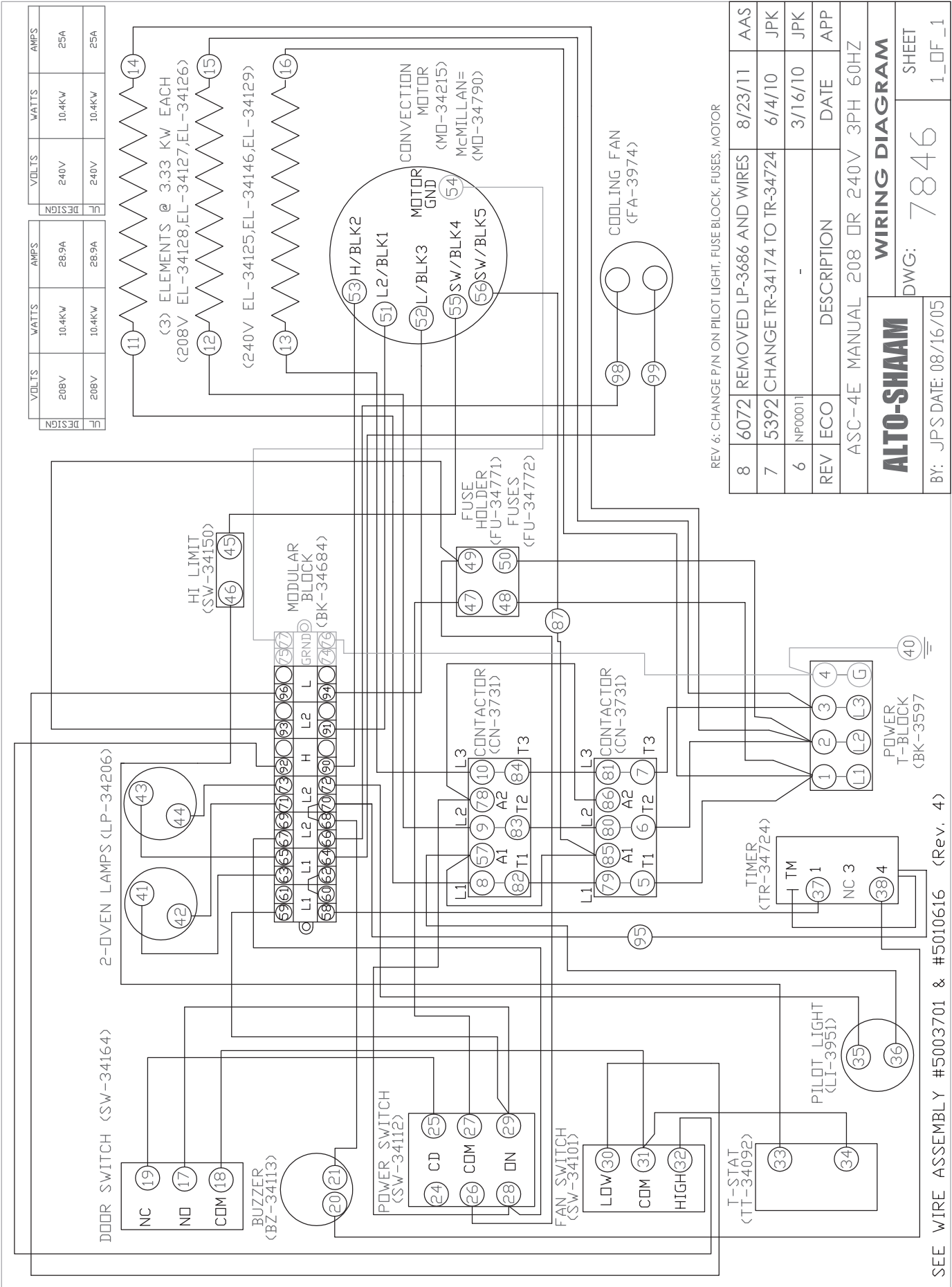

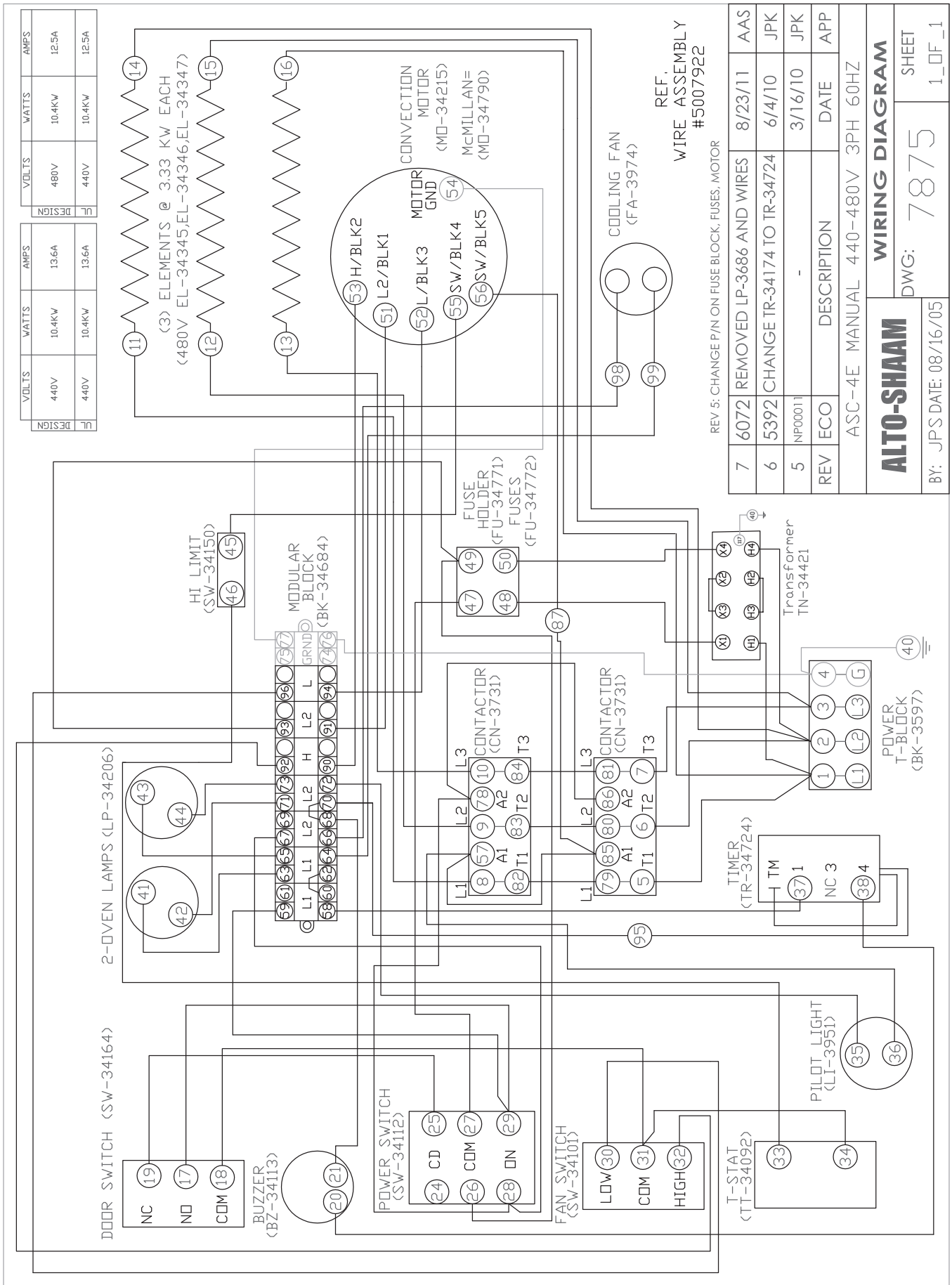

TRANSPORTATION DAMAGE and CLAIMS



All Alto-Shaam equipment is sold F.O.B. shipping point, and when accepted by the carrier, such shipments become the property of the consignee.

Should damage occur in shipment, it is a matter between the carrier and the consignee. In such cases, the carrier is assumed to be responsible for the safe delivery of the merchandise, unless negligence can be established on the part of the shipper.

1. Make an immediate inspection while the equipment is still in the truck or immediately after it is moved to the receiving area. Do not wait until after the material is moved to a storage area.
2. Do not sign a delivery receipt or a freight bill until you have made a proper count and inspection of all merchandise received.
3. Note all damage to packages directly on the carrier's delivery receipt.
4. Make certain the driver signs this receipt. If he refuses to sign, make a notation of this refusal on the receipt.
5. If the driver refuses to allow inspection, write the following on the delivery receipt:
Driver refuses to allow inspection of containers for visible damage.
6. Telephone the carrier's office immediately upon finding damage, and request an inspection. Mail a written confirmation of the time, date, and the person called.
7. Save any packages and packing material for further inspection by the carrier.
8. Promptly file a written claim with the carrier and attach copies of all supporting paperwork.

We will continue our policy of assisting our customers in collecting claims which have been properly filed and actively pursued. We cannot, however, file any damage claims for you, assume the responsibility of any claims, or accept deductions in payment for such claims.

LIMITED WARRANTY

Alto-Shaam, Inc. warrants to the original purchaser only that any original part that is found to be defective in material or workmanship will, at Alto-Shaam's option, subject to provisions hereinafter stated, be replaced with a new or rebuilt part.

The parts warranty period is as follows:

For the refrigeration compressor on Alto-Shaam Quickchillers™, five (5) years from the date of installation.

For the heating element on Halo Heat® cooking and holding ovens, as long as the original purchaser owns the oven. This excludes holding only equipment.

For all other parts, one (1) year from the date of installation or fifteen (15) months from the shipping date, whichever occurs first.

The labor warranty period is one (1) year from the date of installation or fifteen (15) months from the shipping date, whichever occurs first.

Alto-Shaam will bear normal labor charges performed during standard business hours, excluding overtime, holiday rates or any additional fees.

To be valid, a warranty claim must be asserted during the applicable warranty period. This warranty is not transferable.

THIS WARRANTY DOES NOT APPLY TO:

1. Calibration.
2. Replacement of light bulbs, door gaskets, and/or the replacement of glass due to damage of any kind.
3. Equipment damage caused by accident, shipping, improper installation or alteration.
4. Equipment used under conditions of abuse, misuse, carelessness or abnormal conditions, including but not limited to, equipment subjected to harsh or inappropriate chemicals, including but not limited to, compounds containing chloride or quaternary salts, poor water quality, or equipment with missing or altered serial numbers.
5. Damage incurred as a direct result of poor water quality, inadequate maintenance of steam generators and/or surfaces affected by water quality. Water quality and required maintenance of steam generating equipment is the responsibility of the owner/operator.
6. Damage caused by use of any cleaning agent other than Alto-Shaam's Combitherm® Cleaner, including but not limited to damage due to chlorine or other harmful chemicals. **Use of Alto-Shaam's Combitherm® Cleaner on Combitherm® ovens is highly recommended.**
7. Any losses or damage resulting from malfunction, including loss of product, food product, revenue, or consequential or incidental damages of any kind.
8. Equipment modified in any manner from original model, substitution of parts other than factory authorized parts, removal of any parts including legs, or addition of any parts.

This warranty is exclusive and is in lieu of all other warranties, express or implied, including the implied warranties of merchantability and fitness for a particular purpose. In no event shall Alto-Shaam be liable for loss of use, loss of revenue or profit, or loss of product, or for any indirect, special, incidental, or consequential damages. No person except an officer of Alto-Shaam, Inc. is authorized to modify this warranty or to incur on behalf of Alto-Shaam any other obligation or liability in connection with Alto-Shaam equipment.



Effective November 1, 2011

RECORD THE MODEL AND SERIAL NUMBER OF THE APPLIANCE FOR EASY REFERENCE.

ALWAYS REFER TO BOTH MODEL AND SERIAL NUMBER IN ANY CONTACT WITH ALTO-SHAAM REGARDING THIS APPLIANCE.

Model: _____ Date Installed: _____
Voltage: _____ Purchased From: _____
Serial Number: _____

W164 N9221 Water Street • P.O. Box 450 • Menomonee Falls, Wisconsin 53052-0450 • U.S.A.
PHONE: 262.251.3800 • 800.558-8744 USA/CANADA FAX: 262.251.7067 • 800.329.8744 U.S.A. ONLY

www.alto-shaam.com

PRINTED IN U.S.A.