

Alvarion BreezeNET B300

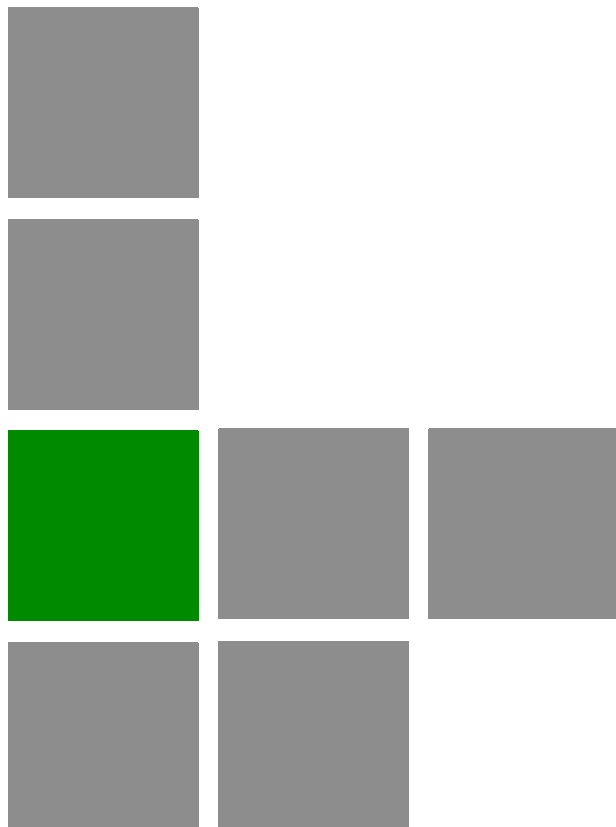

Technical User Manual

Software Version: 1.2
April 2009
P/N 215267

Document History

Changed Item	Description	Date
First revision	Document's first revision	April 2009

Legal Rights

© Copyright 2009 Alvarion Ltd. All rights reserved.

The material contained herein is proprietary, privileged, and confidential and owned by Alvarion or its third party licensors. No disclosure thereof shall be made to third parties without the express written permission of Alvarion Ltd.

Alvarion Ltd. reserves the right to alter the equipment specifications and descriptions in this publication without prior notice. No part of this publication shall be deemed to be part of any contract or warranty unless specifically incorporated by reference into such contract or warranty.

Trade Names

Alvarion[®], BreezeCOM[®], WALKair[®], WALKnet[®], BreezeNET[®], BreezeACCESS[®], BreezeMANAGE[™], BreezeLINK[®], BreezeConfig[™], BreezeMAX[™], AlvariSTAR[™], AlvariCRAFT[™], BreezeLITE[™], MGW[™], eMGW[™], 4Motion[™], and/or other products and/or services referenced here in are either registered trademarks, trademarks or service marks of Alvarion Ltd.

All other names are or may be the trademarks of their respective owners.

Statement of Conditions

The information contained in this manual is subject to change without notice. Alvarion Ltd. shall not be liable for errors contained herein or for incidental or consequential damages in connection with the furnishing, performance, or use of this manual or equipment supplied with it.

Warranties and Disclaimers

All Alvarion Ltd. ("Alvarion") products purchased from Alvarion or through any of Alvarion's authorized resellers are subject to the following warranty and product liability terms and conditions.

Exclusive Warranty

(a) Alvarion warrants that the Product hardware it supplies and the tangible media on which any software is installed, under normal use and conditions, will be free from significant defects in materials and workmanship for a period of fourteen (14) months from the date of shipment of a given Product to Purchaser (the "Warranty Period"). Alvarion will, at its sole option and as Purchaser's sole remedy, repair or replace any defective Product in accordance with Alvarion's standard R&R procedure.

(b) With respect to the Firmware, Alvarion warrants the correct functionality according to the attached documentation, for a period of fourteen (14) month from

invoice date (the "Warranty Period"). During the Warranty Period, Alvarion may release to its Customers firmware updates, which include additional performance improvements and/or bug fixes, upon availability (the "Warranty"). Bug fixes, temporary patches and/or workarounds may be supplied as Firmware updates.

Additional hardware, if required, to install or use Firmware updates must be purchased by the Customer. Alvarion will be obligated to support solely the two (2) most recent Software major releases.

ALVARION SHALL NOT BE LIABLE UNDER THIS WARRANTY IF ITS TESTING AND EXAMINATION DISCLOSE THAT THE ALLEGED DEFECT IN THE PRODUCT DOES NOT EXIST OR WAS CAUSED BY PURCHASER'S OR ANY THIRD PERSON'S MISUSE, NEGLIGENCE, IMPROPER INSTALLATION OR IMPROPER TESTING, UNAUTHORIZED ATTEMPTS TO REPAIR, OR ANY OTHER CAUSE BEYOND THE RANGE OF THE INTENDED USE, OR BY ACCIDENT, FIRE, LIGHTNING OR OTHER HAZARD.

Disclaimer

(a) The Software is sold on an "AS IS" basis. Alvarion, its affiliates or its licensors MAKE NO WARRANTIES, WHATSOEVER, WHETHER EXPRESS OR IMPLIED, WITH RESPECT TO THE SOFTWARE AND THE ACCOMPANYING DOCUMENTATION. ALVARION SPECIFICALLY DISCLAIMS ALL IMPLIED WARRANTIES OF MERCHANTABILITY AND FITNESS FOR A PARTICULAR PURPOSE AND NON-INFRINGEMENT WITH RESPECT TO THE SOFTWARE. UNITS OF PRODUCT (INCLUDING ALL THE SOFTWARE) DELIVERED TO PURCHASER HEREUNDER ARE NOT FAULT-TOLERANT AND ARE NOT DESIGNED, MANUFACTURED OR INTENDED FOR USE OR RESALE IN APPLICATIONS WHERE THE FAILURE, MALFUNCTION OR INACCURACY OF PRODUCTS CARRIES A RISK OF DEATH OR BODILY INJURY OR SEVERE PHYSICAL OR ENVIRONMENTAL DAMAGE ("HIGH RISK ACTIVITIES"). HIGH RISK ACTIVITIES MAY INCLUDE, BUT ARE NOT LIMITED TO, USE AS PART OF ON-LINE CONTROL SYSTEMS IN HAZARDOUS ENVIRONMENTS REQUIRING FAIL-SAFE PERFORMANCE, SUCH AS IN THE OPERATION OF NUCLEAR FACILITIES, AIRCRAFT NAVIGATION OR COMMUNICATION SYSTEMS, AIR TRAFFIC CONTROL, LIFE SUPPORT MACHINES, WEAPONS SYSTEMS OR OTHER APPLICATIONS REPRESENTING A SIMILAR DEGREE OF POTENTIAL HAZARD. ALVARION SPECIFICALLY DISCLAIMS ANY EXPRESS OR IMPLIED WARRANTY OF FITNESS FOR HIGH RISK ACTIVITIES.

(b) PURCHASER'S SOLE REMEDY FOR BREACH OF THE EXPRESS WARRANTIES ABOVE SHALL BE REPLACEMENT OR REFUND OF THE PURCHASE PRICE AS SPECIFIED ABOVE, AT ALVARION'S OPTION. TO THE FULLEST EXTENT ALLOWED BY LAW, THE WARRANTIES AND REMEDIES SET FORTH IN THIS AGREEMENT ARE EXCLUSIVE AND IN LIEU OF ALL OTHER

WARRANTIES OR CONDITIONS, EXPRESS OR IMPLIED, EITHER IN FACT OR BY OPERATION OF LAW, STATUTORY OR OTHERWISE, INCLUDING BUT NOT LIMITED TO WARRANTIES, TERMS OR CONDITIONS OF MERCHANTABILITY, FITNESS FOR A PARTICULAR PURPOSE, SATISFACTORY QUALITY, CORRESPONDENCE WITH DESCRIPTION, NON-INFRINGEMENT, AND ACCURACY OF INFORMATION GENERATED. ALL OF WHICH ARE EXPRESSLY DISCLAIMED. ALVARION' WARRANTIES HEREIN RUN ONLY TO PURCHASER, AND ARE NOT EXTENDED TO ANY THIRD PARTIES. ALVARION NEITHER ASSUMES NOR AUTHORIZES ANY OTHER PERSON TO ASSUME FOR IT ANY OTHER LIABILITY IN CONNECTION WITH THE SALE, INSTALLATION, MAINTENANCE OR USE OF ITS PRODUCTS.

Limitation of Liability

(a) ALVARION SHALL NOT BE LIABLE TO THE PURCHASER OR TO ANY THIRD PARTY, FOR ANY LOSS OF PROFITS, LOSS OF USE, INTERRUPTION OF BUSINESS OR FOR ANY INDIRECT, SPECIAL, INCIDENTAL, PUNITIVE OR CONSEQUENTIAL DAMAGES OF ANY KIND, WHETHER ARISING UNDER BREACH OF CONTRACT, TORT (INCLUDING NEGLIGENCE), STRICT LIABILITY OR OTHERWISE AND WHETHER BASED ON THIS AGREEMENT OR OTHERWISE, EVEN IF ADVISED OF THE POSSIBILITY OF SUCH DAMAGES.

(b) TO THE EXTENT PERMITTED BY APPLICABLE LAW, IN NO EVENT SHALL THE LIABILITY FOR DAMAGES HEREUNDER OF ALVARION OR ITS EMPLOYEES OR AGENTS EXCEED THE PURCHASE PRICE PAID FOR THE PRODUCT BY PURCHASER, NOR SHALL THE AGGREGATE LIABILITY FOR DAMAGES TO ALL PARTIES REGARDING ANY PRODUCT EXCEED THE PURCHASE PRICE PAID FOR THAT PRODUCT BY THAT PARTY (EXCEPT IN THE CASE OF A BREACH OF A PARTY'S CONFIDENTIALITY OBLIGATIONS).

Radio Frequency Interference Statement

The Subscriber Unit equipment has been tested and found to comply with the limits for a class B digital device, pursuant to ETSI EN 301 489-1 rules and Part 15 of the FCC Rules. These limits are designed to provide reasonable protection against harmful interference when the equipment is operated in a residential environment notwithstanding use in commercial, business and industrial environments. This equipment generates, uses, and can radiate radio frequency energy and, if not installed and used in accordance with the instruction manual, may cause harmful interference to radio communications.

FCC Radiation Hazard Warning

To comply with FCC RF exposure requirement, the antenna used for this equipment must be fixed-mounted on outdoor permanent structures with a separation distance of at least 2 meters from all persons.

Disposal of Electronic and Electrical Waste



Disposal of Electronic and Electrical Waste

Pursuant to the WEEE EU Directive electronic and electrical waste must not be disposed of with unsorted waste. Please contact your local recycling authority for disposal of this product.

Important Notice

This user manual is delivered subject to the following conditions and restrictions:

- This manual contains proprietary information belonging to Alvarion Ltd. Such information is supplied solely for the purpose of assisting properly authorized users of the respective Alvarion products.
- No part of its contents may be used for any other purpose, disclosed to any person or firm or reproduced by any means, electronic and mechanical, without the express prior written permission of Alvarion Ltd.
- The text and graphics are for the purpose of illustration and reference only. The specifications on which they are based are subject to change without notice.
- The software described in this document is furnished under a license. The software may be used or copied only in accordance with the terms of that license.
- Information in this document is subject to change without notice. Corporate and individual names and data used in examples herein are fictitious unless otherwise noted.
- Alvarion Ltd. reserves the right to alter the equipment specifications and descriptions in this publication without prior notice. No part of this publication shall be deemed to be part of any contract or warranty unless specifically incorporated by reference into such contract or warranty.
- The information contained herein is merely descriptive in nature, and does not constitute an offer for the sale of the product described herein.
- Any changes or modifications of equipment, including opening of the equipment not expressly approved by Alvarion Ltd. will void equipment warranty and any repair thereafter shall be charged for. It could also void the user's authority to operate the equipment.

About this Manual

This User Manual is a description of Alvarion devices and contains installation and configuration guidelines, recommendations and troubleshooting sections, and supplementary materials. The document is intended to be used by Qualified RF engineers/technicians and IT professionals. Qualified personnel should have skills and experience in the following areas:

- Outdoor/indoor radio equipment installation
- Outdoor wireless networks
- TCP/IP networking protocols
- Safety procedures and instructions for installing antenna equipment
- Professional manage of electrical equipment and accessories

Safety procedures and instructions for working on towers and heights

Contents

Chapter 1 - Getting Started	1
1.1 Scope of Document.....	3
1.2 Abbreviations	4
1.3 Document Marks	5
Chapter 2 - Hardware Description	6
2.1 Power supply units (IDU).....	8
2.1.1 IDU-BS	8
2.2 Outdoor Units (ODU).....	10
2.2.1 BU/RB-B300D-5X	10
2.2.2 BU/RB-B300-5X	11
2.2.3 ODU LED Indicators Description.....	12
2.3 Installation Preparations	13
2.3.1 Required Components and Accessories.....	13
2.3.2 Antenna Placement.....	13
2.3.3 Antenna Poles Usage	15
2.3.4 Poles with Stretching.....	15
2.3.5 Wall Mounted Pole	15
2.3.6 Antenna Poles Requirements	15
2.3.7 Grounding when Using IDU-BS	15
2.3.8 Antenna Alignment.....	16
2.3.9 Precaution Measures	17
2.3.10 Service Cable Soldering Procedure	17
2.3.11 Tools Required at the Installation Site	20
2.4 BU/RB-B300D-5X.....	21
2.4.1 Installation Guidelines	21
2.4.2 Tube Mounting for ODU	23
2.5 BU/RB-B300-5X.....	25
2.5.1 Installation Guidelines	25

2.5.2 Pole Mounting Kit Assembling	27
2.6 Mounting Kits Assembling	28
2.6.1 Pole Mounting Kit MONT-5000-V.Pole-KIT for Vertical Mast.....	28
2.6.2 Pole Mounting Kit MONT-5000-H.Pole-KIT for Horizontal Pole.....	29
2.7 Specifications	31
2.7.1 Radio.....	31
2.7.2 Antenna.....	33
2.7.3 Data Communication.....	33
2.7.4 Configuration Management.....	34
2.7.5 Electrical Characteristics.....	34
2.7.6 Physical and Environmental.....	34
2.7.7 Standards and Regulations.....	35
Chapter 3 - Basic Configuration Instructions	36
3.1 Initial Settings Configuration Procedure	38
3.2 Device Interfaces.....	40
3.3 Command Line Interface (CLI)	41
3.4 Lost Password Recovery.....	42
3.5 Configuration Manipulations.....	45
3.5.1 Printing and Saving Your Configuration	45
3.5.2 Import/Export.....	45
3.5.3 IP Address Formats	45
3.6 Ethernet Interface Configuration	47
3.7 Radio Interface Configuration.....	48
Chapter 4 - Link Configuration	50
4.1 Link Diagnostic Tools	52
4.1.1 Ltest	52
4.1.2 Muffer	55
4.1.3 Load Meter	59
4.1.4 Acquiring Interfaces Statistics	59
4.1.5 RapidView	60

Chapter 5 - Configuration Via Web Interface.....	66
5.1 Overall Functionality Overview.....	68
5.2 Run Requirements	69
5.3 Basic Settings.....	70
5.4 Device Status.....	73
5.5 Maintenance.....	75
5.6 Spectrum Analyzer.....	76
Chapter 6 - Supplementary Information.....	78
6.1 "RJ-45" Service Cable Connector Soldering Scheme	80
6.2 Console Cable Connector Soldering Scheme	81

List of Tables

Table 2-1: ODU LED Indicators Description.....	12
Table 2-2: RJ-45 Connector Soldering Procedure	18
Table 2-3: Radio Specifications.....	31
Table 2-4: Maximum Peak Channel Power Levels	33
Table 2-5: Antenna Specifications	33
Table 2-6: Data Communication Specifications	33
Table 2-7: Configuration Management Specifications.....	34
Table 2-8: Electrical Characteristics Specifications.....	34
Table 2-9: Physical and Environmental Specifications.....	34
Table 2-10: Standards and Regulations Compliance.....	35
Table 4-1: Indicator LEDs	64

List of Figures

Figure 2-1: IDU-BS Top View	8
Figure 2-2: IDU-BS Front Panel	8
Figure 2-3: IDU-BS Rear Panel.....	9
Figure 2-4: Connection scheme for IDU-BS.....	9
Figure 2-5: BU/RB-B300D-5X Front Panel.....	10
Figure 2-6: BU/RB-B300D-5X Top View	11
Figure 2-7: BU/RB-B300-5X Front Panel	11
Figure 2-8: BU/RB-B300-5X Top View.....	12
Figure 2-9: Grounding	16
Figure 2-10: BU/RB-B300D-5X Installation 1	21
Figure 2-11: BU/RB-B300D-5X Installation 2	22
Figure 2-12: Tube Mounting 1	23
Figure 2-13: Tube Mounting 2	24
Figure 2-14: BU/RB-B300-5X Installation 1.....	25
Figure 2-15: BU/RB-B300-5X Installation 2.....	26
Figure 2-16: Pole Mounting Kit Assembling 1	27
Figure 2-17: Pole Mounting Kit Assembling 2	27
Figure 2-18: MONT-5000-V.Pole-KIT 1.....	28
Figure 2-19: MONT-5000-V.Pole-KIT 2.....	29
Figure 2-20: MONT-5000-H.Pole-KIT 1	30
Figure 2-21: MONT-5000-H.Pole-KIT 2	30
Figure 3-1: ERConsole (Step 1).....	42
Figure 3-2: ERConsole (Step 2).....	43
Figure 3-3: ERConsole (Step 3).....	44
Figure 4-1: Ltest	52
Figure 4-2: Ltest Align	54
Figure 4-3: Ltest Bandwidth Meter	54

Figure 4-4: Muffer Review Mode	55
Figure 4-5: Muffer MAC2 Mode.....	56
Figure 4-6: Muffer Statistics Mode	57
Figure 4-7: Load Meter.....	59
Figure 4-8: Netstat	60
Figure 4-9: RapidView Top.....	61
Figure 4-10: RapidView Back.....	62
Figure 4-11: RapidView Indicator Panel.....	62
Figure 5-1: Basic Settings	70
Figure 5-2: Device Status.....	73
Figure 5-3: Maintenance	75
Figure 5-4: Spectrum Analyzer.....	76
Figure 6-1: Service Cable Connector Soldering Scheme.....	80
Figure 6-2: Console Cable Connector Soldering Scheme	81

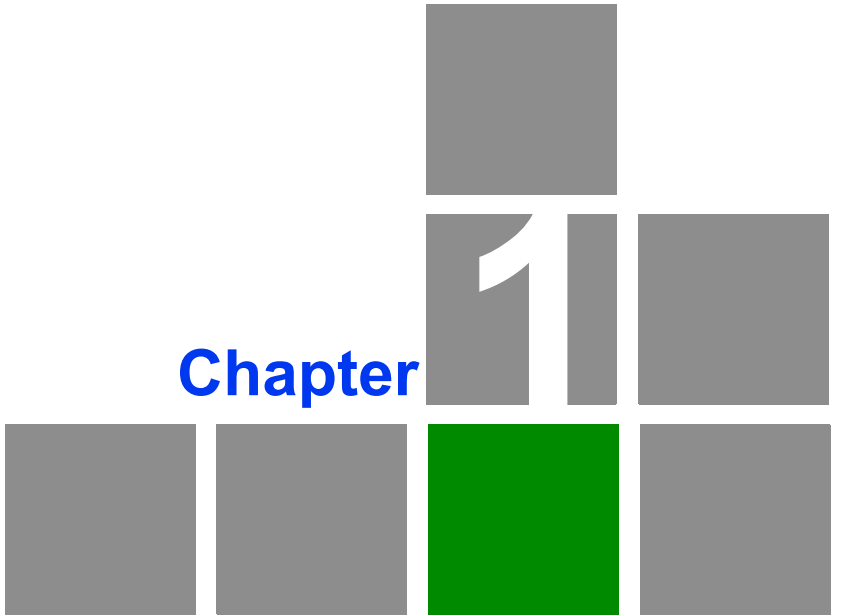
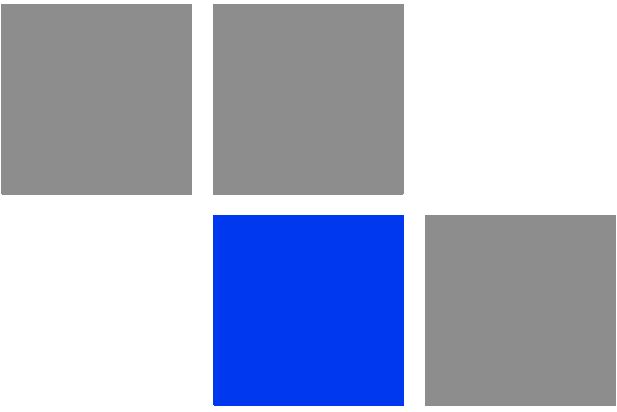

Getting Started

In This Chapter:

- “Scope of Document” on page 3
- “Abbreviations” on page 4
- “Document Marks” on page 5

1.1 Scope of Document

This document consists of the following chapters:

- [“Getting Started” on page 1](#) - This chapter includes the information about this document purpose and structure.
- [“Hardware Description” on page 6](#) - This chapter shows the devices appearance and all plugs and connectors.
- [“Basic Configuration Instructions” on page 36](#) - This chapter includes basic recommendations for primary link configuration, including interfaces configuration and MINT protocol usage. Also there is a description of how to perform basic manipulations with device's configuration including its updating, importing and exporting.
- [“Link Configuration” on page 50](#) - The chapter contains basic recommendations for making preliminary choices and decisions while planning and deploying a wireless network based on the Devices. It also describes a set of tools that can help while improving the link quality and statistics gathering.
- [“Configuration Via Web Interface” on page 66](#) - This chapter describes the device's built-in services, features and tools which were not described in previous parts of the document.
- [“Supplementary Information” on page 78](#) - Contains supplementary information (specifications, connectors soldering scheme).

1.2 Abbreviations

The following abbreviations are used in this document:

- ODU - Outdoor Unit
- IDU - Indoor power supply Unit
- RF cable - Radio Frequency cable to connect ODU and external antenna in case connectorized version of the unit is used
- LOS - Line-of-Sight
- STP cable - Shielded Twisted Pair cable (STP Cat5E) to connect ODU and IDU
- PTP - Point-to-Point topology
- MINT - Microwave Interconnection NeTworks

1.3 Document Marks

CAUTION



All caution warnings are marked with a special warning sign. One should pay a great deal of attention to what is written in the Warning sections.

NOTE



All notes are marked with a special note sign. Notes usually contain useful comments or hints to the described section of the document.

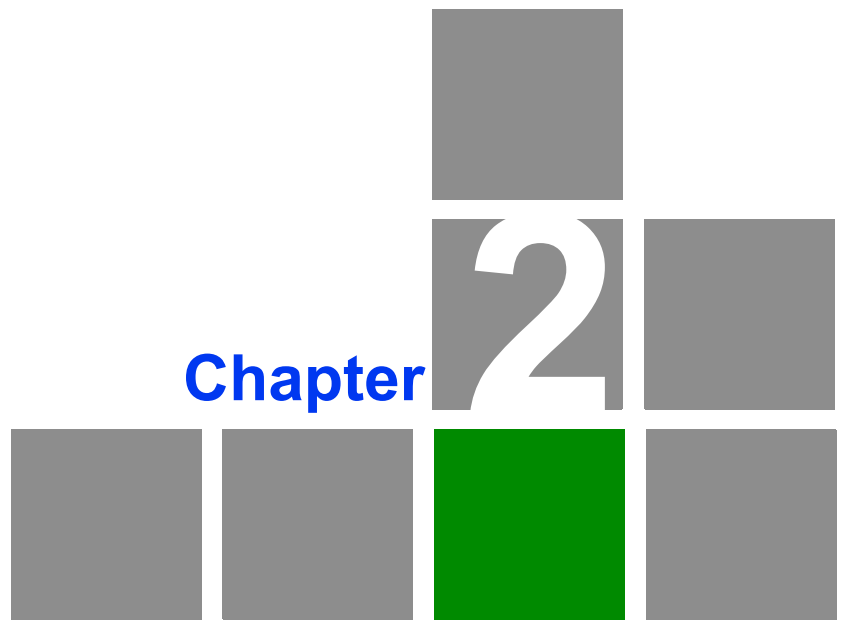
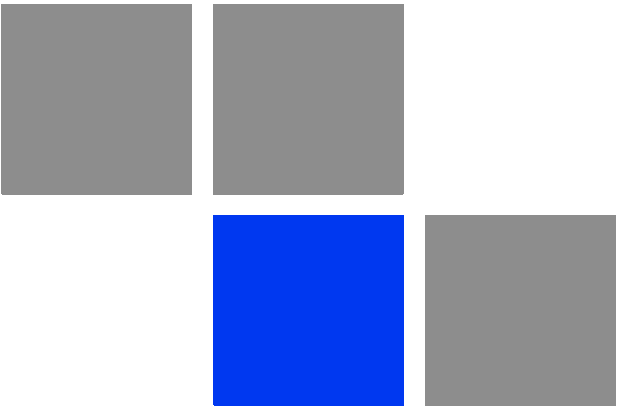

Hardware Description

In This Chapter

- “Power supply units (IDU)” on page 8
- “Outdoor Units (ODU)” on page 10
- “Installation Preparations” on page 13
- “BU/RB-B300D-5X” on page 21
- “BU/RB-B300-5X” on page 25
- “Mounting Kits Assembling” on page 28

2.1 Power supply units (IDU)

2.1.1 IDU-BS

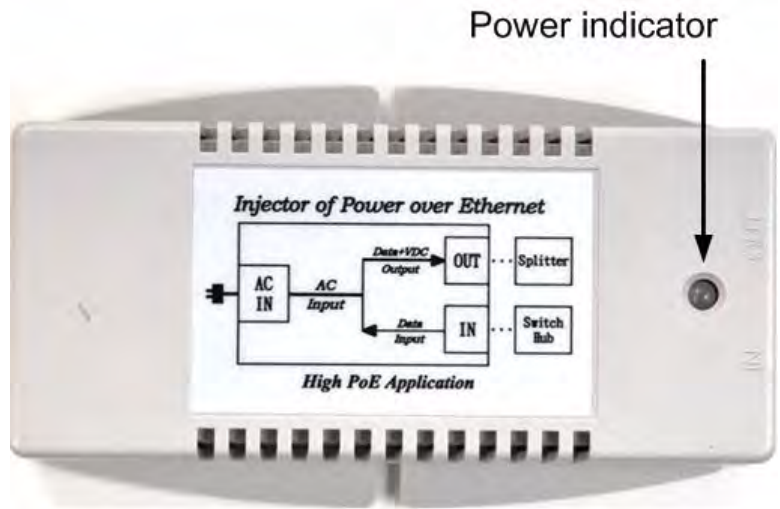

Figure 2-1: IDU-BS Top View

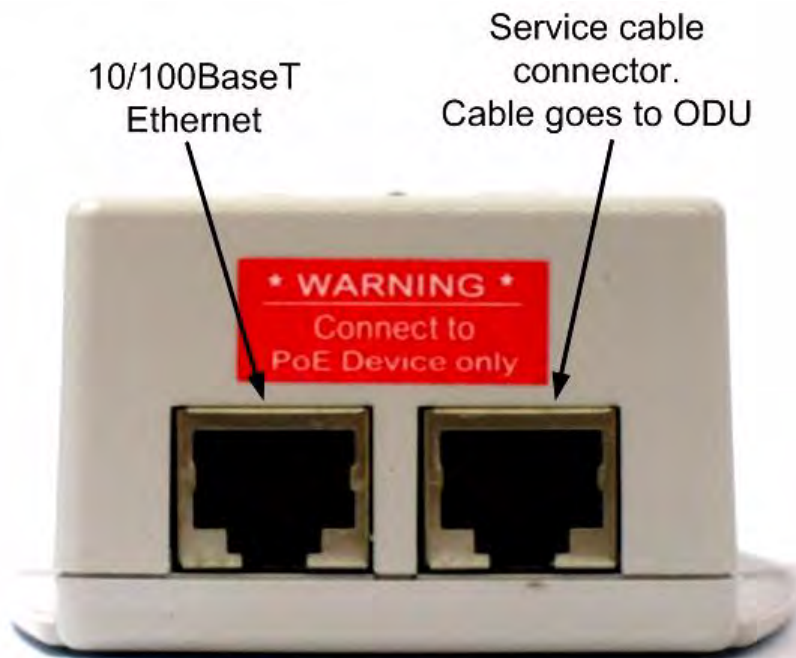

Figure 2-2: IDU-BS Front Panel



Figure 2-3: IDU-BS Rear Panel

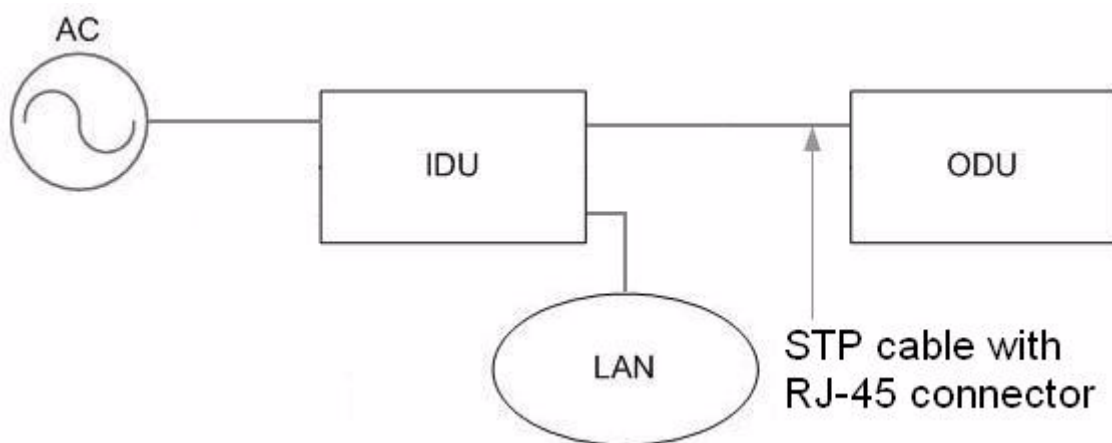

Figure 2-4: Connection scheme for IDU-BS

2.2 Outdoor Units (ODU)

2.2.1 BU/RB-B300D-5X

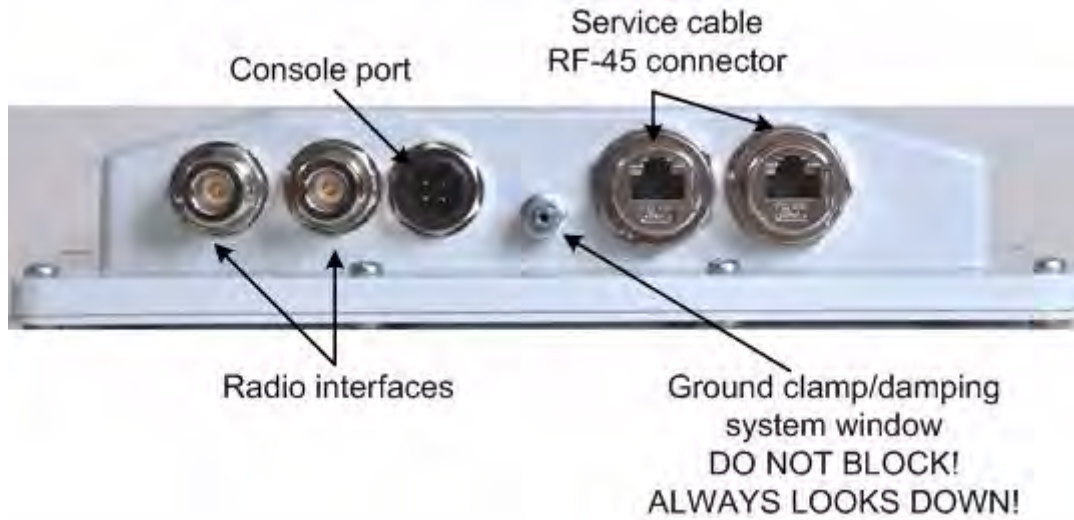

Figure 2-5: BU/RB-B300D-5X Front Panel

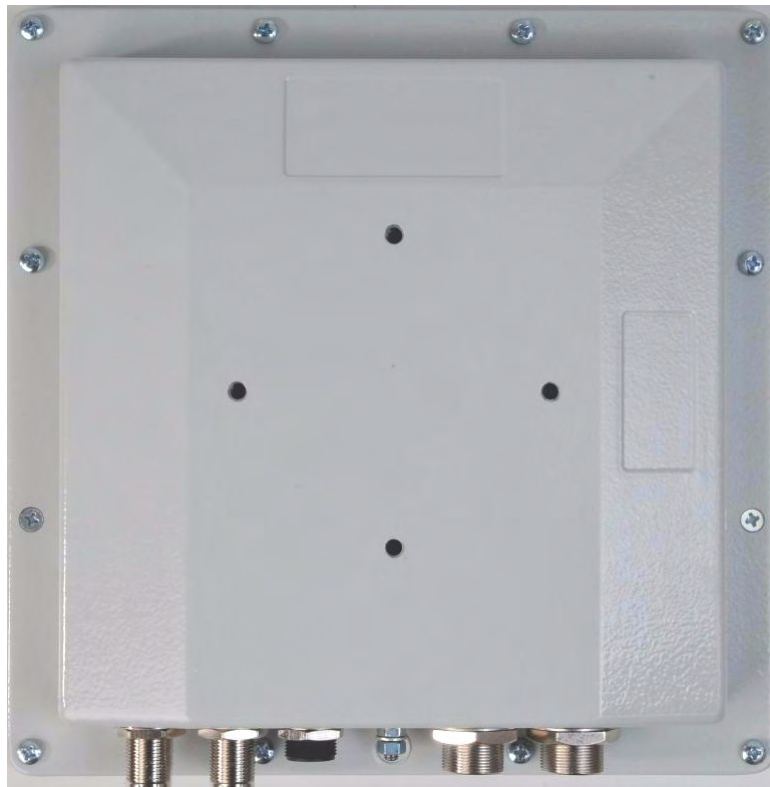

Figure 2-6: BU/RB-B300D-5X Top View

2.2.2 BU/RB-B300-5X

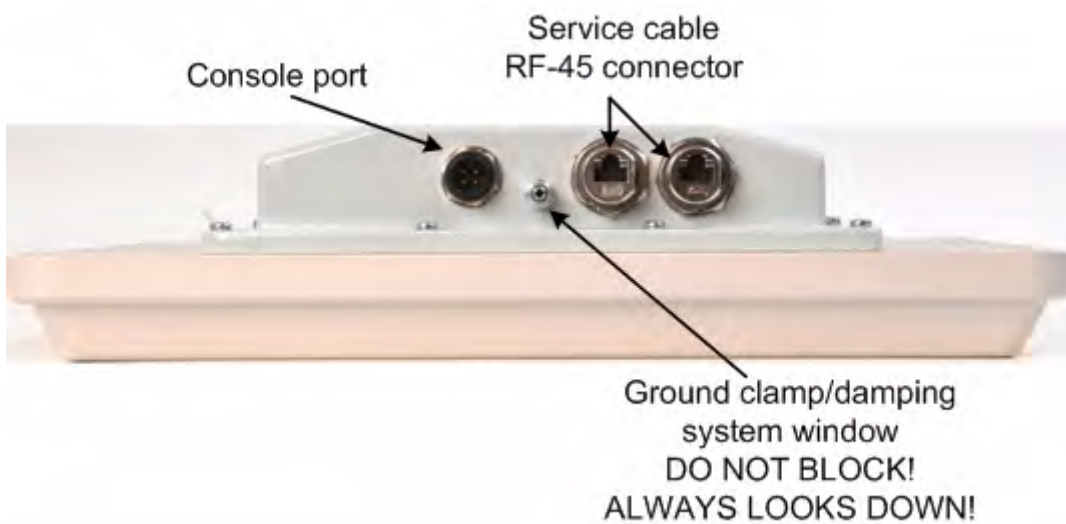

Figure 2-7: BU/RB-B300-5X Front Panel



Figure 2-8: BU/RB-B300-5X Top View

2.2.3 ODU LED Indicators Description

ODU units have two LED indicators (red and green) located in the Console connector. These LEDs are useful in monitoring the device status during the installation procedure. LEDs modes and Device status correspondence is shown in the following table:

Table 2-1: ODU LED Indicators Description

Red Indicator	Green Indicator	Device Status
Off	Off	Device is switched off or in the process of start-up booting
Off	Blinking	Device is booted. No radio connection. Searching for another device to establish radio connection to.
Blinking	On	Radio connection established. The more data is transmitted through the radio channel the more frequently red indicator is blinking.

2.3 Installation Preparations

2.3.1 Required Components and Accessories

Before the installation, please make sure you have all necessary parts and accessories:

- Device
- Antenna
- Low loss antenna cable for the required frequency range
- Antenna pole (if necessary)
- Required grounding system
- Accessories and tools

2.3.2 Antenna Placement

When planning an antenna placement for PTP link, in order to obtain the maximal coverage range and best performance for the Device, one need to consider that LOS requirements must be fulfilled for the path between two antennas. Moreover, it is of vital importance that the certain zone that surrounds the signal propagation path must be free from obstructions. One should understand that the radio beam is not as thin as, for example, laser beam. Radio beam, also called as a 1st Fresnel zone, has a profile of a rugby ball. Its exact form and size depend upon the frequency and the signal propagation path length.

If most of the 1st Fresnel zone is obstructed, a major part of a electromagnetic energy will be lost which leads to a severe signal quality degradation and, as a result, to coverage range decreasing.

Below is an incomplete list of possible obstructions on the signal propagation path:

- Neighboring buildings
- Trees
- Bridges

■ Power lines

To obtain the best results, it is necessary to perform a precise analysis of a signal propagation path zone and possible obstructions that may cover a part of the 1st Fresnel zone (usually the analysis is performed at the highest points of the signal propagation path).

NOTE



While planning, it is strongly recommended to consult high-qualified and experienced technicians

NOTE



Antenna installation must be performed only by a professional installer.

The system must be configured only as point to point. The maximum power at the antenna connector, described in [Table 2-3](#) and [Table 2-4](#), is applicable for both qualified antennas and for each channel bandwidth

General recommendation for antennas placement are the following:

- Install antennas as high as possible over specific level. In case of flat surface - it will be ground level, in case of vegetation and forest - it will be tree heights, in urban environment - it will be the highest building in the observed area (specific level definition).
- Avoid tree and vegetation along with wave propagation path, influence of trees can increase depending on seasons (ice, dew, leaves);
- Proximity of other antennas should be avoided (at least 2 meters);
- Reflecting surfaces should be considered (building with reflective windows, water surfaces or wet grounds);
- When installing antenna over water surface, one should tune height bracket within 1-3 meter range variation, because it can yield signal level variation from minimum to maximum.
- If seasonal changes influence on the signal quality, so then the most probable reasons would be either the connectors are not protected enough from humidity, summer vegetation or ice covered cabling and connectors during winter.

2.3.3 Antenna Poles Usage

Antenna installation is performed on a special facility called antenna pole. The pole is used for strong antenna tightening at the installation site. Poles might have different modifications depending on the installation requirements.

2.3.4 Poles with Stretching

Usually this kind of poles are used when installing antenna on a flat surface and permits one to raise it to a significant height for providing optimal conditions for signal propagation.

2.3.5 Wall Mounted Pole

Usually these kinds of poles are used when there is no need to elevate antenna to the rooftop and there is the possibility to mounting it on a wall. This installation is significantly simpler than that implementation with poles. Mostly it is used for subscriber side deployments.

2.3.6 Antenna Poles Requirements

Ease of antenna mounting and sufficient mechanical durability should provide reliable fastening in conditions of high windy loads. Poles should have round profile for ease of azimuth adjustment. Typical pole diameter is 30 to 50 mm.

2.3.7 Grounding when Using IDU-BS

Antenna should be placed on the mast on the level that is at least 1 meter lower than a mast's top. In this case it is of big probability that the lightning strikes the mast and not the antenna. The mast is to be grounded on the grounding contour according to your local standards. When the lightning strikes the antenna, the current goes through the coaxial cable which grounds ODU clamp with the mast - the mast is grounded via the grounding contour. The direct lightning strike to the STP service cable (ODU-IDU) is partially terminated on the grounded IDU case. Partial termination means that the direct lightning strike will probably destroy an STP cable. The service cable pickups from the electromagnetic impulses are terminated on the IDU case by the winding shield, and further - on the IDU grounding. IDU is grounded via a three-conductor power cord and a plug containing a ground. The data & power wires pickups are terminated via IDU protection scheme (three-conductor power cord and a plug containing a ground).

CAUTION

Antenna pole, tower, ODU and lightning arrester should be connected to the first common grounding contour. Cable thickness should be no less than 10AWG using corrosion-steady connectors. It is highly recommended to entrust grounding contour development to the skilled personnel.

A special attention should be paid if antenna used is not DC-shortened. In this case additional lightning arrester should be used between the antenna and ODU. Suggested grounding diagram is shown on the picture below.

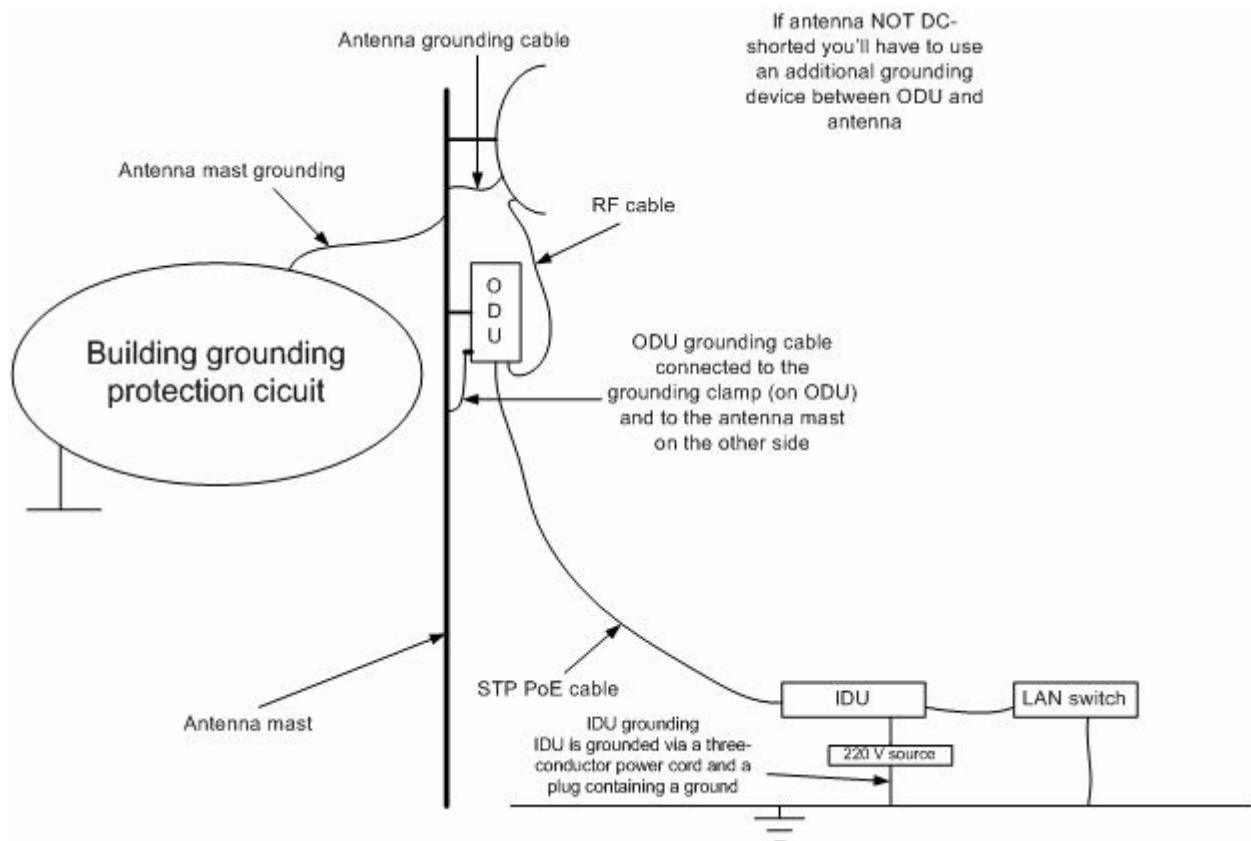

Figure 2-9: Grounding

2.3.8 Antenna Alignment

To obtain maximal system performance antennas must be precisely aligned one towards another according to LOS requirements. General recommendations for antenna alignment are the following:

- Align antennas using optical equipment (binoculars, spyglass) accompanied by mobile phone actions coordination

- Use GPS receiver and area map
- Use build-in Device features. These features allow evaluating current channel/signal quality and perform precise antenna alignment

2.3.9 Precaution Measures

Before you start the installation please read this section very carefully.

Antennas are installed on the roof tops or on the building walls. This work must be accomplished only by personnel having special skills and experience in this area.

Antennas and cables are electric conductors. Incidental electrostatic strikes may occur during the system installation. This can lead to equipment damaging or may hurt the personnel. While installing or changing the elements of the antenna-fider system one should make sure that open metal parts are temporarily grounded.

Do not install the antenna close to the electric power lines. Antenna and antenna pole have to be installed in such a way that while their assembling, disassembling and repairing they did not have any contact with power lines.

Basic precaution measures that must be fulfilled during the installation are the following:

- Do not stay on the roof top in windy or rainy weather, during the thunderstorm or when the working zone is covered with snow or ice
- Do not touch the antennas, antenna poles, cables and lighting arrestors during the thunderstorm
- Antenna placement should not be close to electric or telephone lines. Safe distance is a distance that is a sum of the two antenna poles heights and antenna height

2.3.10 Service Cable Soldering Procedure

The following instruction shows the "RJ-45" (modification 2) connector soldering procedure.

Table 2-2: RJ-45 Connector Soldering Procedure

Illustration	Description
	<p>Step 1. Peel STP service cable and prepare "RJ-45" connector parts.</p> <p>Use RJ-45 connector without grounding here (RJ-45 connector with grounding is used for connecting service cable to IDU).</p>
	<p>Step 2. Stick rubber filler - 5 on the Part 4, previously having removed protective white layer from rubber filler -5.</p> <p>Insert Part 2 inside part 4 up to the stop. Part 2 must be entirely within Part 4.</p>
	<p>Step 3. Put connector parts on the STP service cable as shown.</p> <p>Attach RJ-45 connector without grounding to the STP service cable according to the "RJ-45" soldering scheme and crimp the connector.</p>

Table 2-2: RJ-45 Connector Soldering Procedure

Illustration	Description
	<p>Step 4. Put Part 4 on the attached in the previous step RJ-45 connector.</p>
	<p>Step 5. Screw Part 2 on Part 4. This fixes the "RJ-45" connector on the cable. Check that the connector is properly fixed on the cable.</p>
	<p>Step 6. Assemble the connector to the unit.</p>

Table 2-2: RJ-45 Connector Soldering Procedure

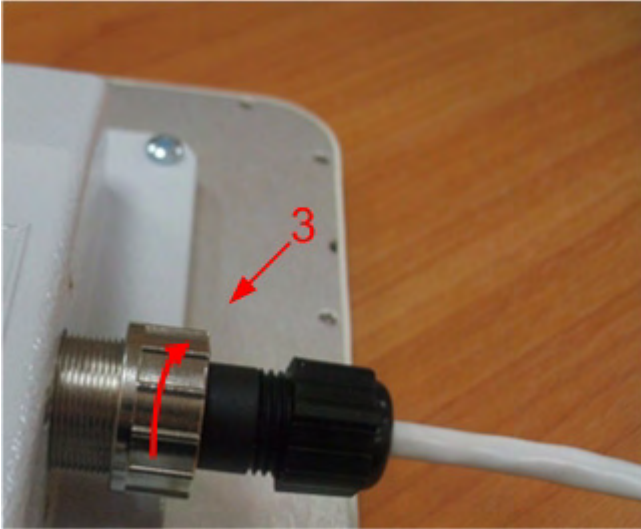
Illustration	Description
	<p>Step 7. Fix the connector by screwing Part 3.</p> <p>Now the connector is hermetically attached to the unit.</p>

2.3.11 Tools Required at the Installation Site

- 1 Screwdrivers set
- 2 Pliers
- 3 Soldering iron 40 W
- 4 Spanners set
- 5 Connectors isolating set
 - » Raw rubber
 - » Thermal shrinkage tube
 - » Scissors
 - » Fan
 - » Mantling gun
- 6 Additional equipment
 - » GPS receiver or area map (with compass and alidade)
 - » Big zoom binoculars

2.4 BU/RB-B300D-5X

2.4.1 Installation Guidelines

- 1 Unpack the equipment
- 2 Check items integrity
- 3 Prepare RF-cables of the required length. The recommended maximal RF cable length is 1 meter.
- 4 Install and isolate the connectors on the RF cables

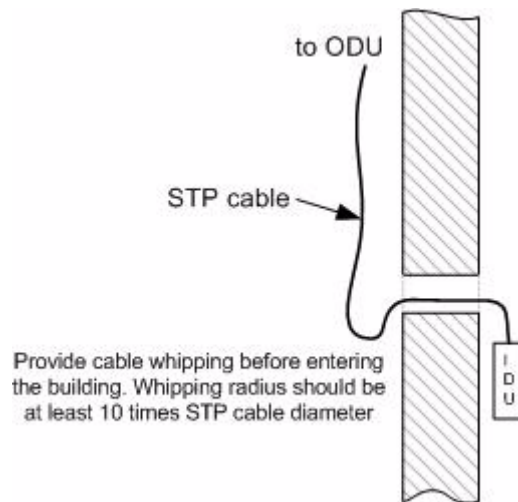

Figure 2-10: BU/RB-B300D-5X Installation 1

- 5 Determine the STP cable length that is used to connect IDU and ODU. The total cable length between LAN (behind IDU) and ODU should not be longer than 100 meters. Service cable connecting IDU and ODU should be STP Cat 5E cable.
- 6 Install (solder) connector for ODU on the STP cable and isolate it
- 7 If it is possible to lay STP cable with a connector on the IDU side, install (solder) connector for IDU on the STP cable and isolate it
- 8 Lay the STP cable "from top to bottom" - from ODU to IDU
- 9 If step 7 is not accomplished, after the STP cable has been laid, install (solder) connector for IDU
- 10 Install ODU on the mounting bracket connectors down and tighten it

- 11 Connect the ODU-IDU cable to the ODU
- 12 Isolate the ODU connector joint place
- 13 Once the antenna and antenna pole are installed they must be grounded via lightning protection grounding contour. Antenna's position must be lower than the highest antenna pole point at least by 2 antenna heights. If antenna is NOT DC-shorted (see antenna technical documentation), the additional lightning arrester must be used which is placed between ODU and antenna and is grounded to the antenna pole grounding contour.

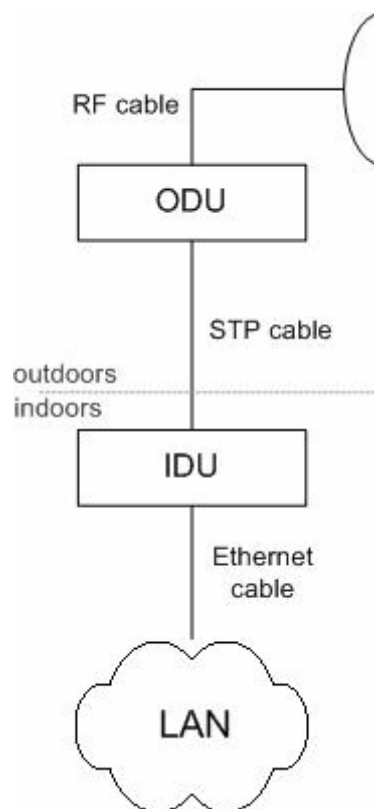

Figure 2-11: BU/RB-B300D-5X Installation 2

- 14 Connect RF cables to the antenna. Twist the connectors tightly
- 15 Connect RF cables to the ODU previously having touched RF cable connectors case with ODU connector case
- 16 Isolate RF connectors from both sides (ODU and antenna)
- 17 Connect the STP cable to IDU previously having touched IDU connector case with STP cable connector case
- 18 Provide grounding for IDU

- 19 Connect Ethernet cable to IDU
- 20 Provide power supply for IDU
- 21 Connect to the Device using Telnet protocol

CAUTION

It is extremely important to install ODU connectors down!



2.4.2 Tube Mounting for ODU



Figure 2-12: Tube Mounting 1



Figure 2-13: Tube Mounting 2

2.5 BU/RB-B300-5X

2.5.1 Installation Guidelines

- 1 Unpack the equipment
- 2 Check items integrity
- 3 Determine the STP cable length that is used to connect IDU and ODU. The total cable length between LAN (behind IDU) and ODU should not be longer than 100 meters.

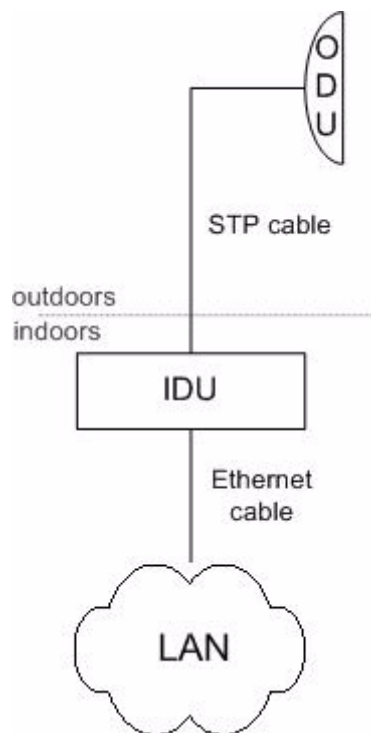

Figure 2-14: BU/RB-B300-5X Installation 1

- 4 Install (solder) connector for ODU on the STP cable and isolate it
- 5 Lay the STP cable "from top to bottom" - from ODU to IDU
- 6 After the STP cable has been laid, use distribution box to switch from STP cable to UTP cable with RJ-45 connectors. Service cable connecting IDU and ODU should be STP Cat 5E cable.
- 7 Install ODU on the mounting bracket according to the direction required for the link. Do not tight it too hard unless the antenna alignment is not complete. Install ODU connectors down.

- 8 Connect the ODU-IDU cable to the ODU
- 9 Isolate the ODU connector joint place
- 10 Once the ODU and antenna pole are installed they must be grounded via lightning protection grounding contour. ODU position must be lower than the highest antenna pole point at least by 2 ODU heights

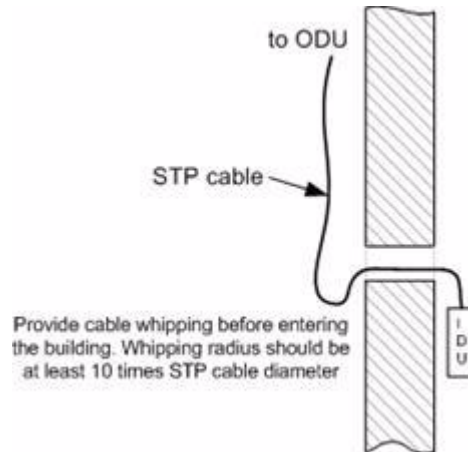

Figure 2-15: BU/RB-B300-5X Installation 2

- 11 Connect the UTP cable to IDU
- 12 Provide grounding for IDU
- 13 Connect Ethernet cable to IDU
- 14 Provide power supply for IDU
- 15 Connect to the Device using Telnet protocol

CAUTION

It is extremely important to install ODU connectors down!



2.5.2 Pole Mounting Kit Assembling



Figure 2-16: Pole Mounting Kit Assembling 1



Figure 2-17: Pole Mounting Kit Assembling 2

2.6 Mounting Kits Assembling

2.6.1 Pole Mounting Kit MONT-5000-V.Pole-KIT for Vertical Mast

CAUTION

Attention! Pole mounting kit MONT-5000-V.Pole-KIT does NOT contain metal straps.

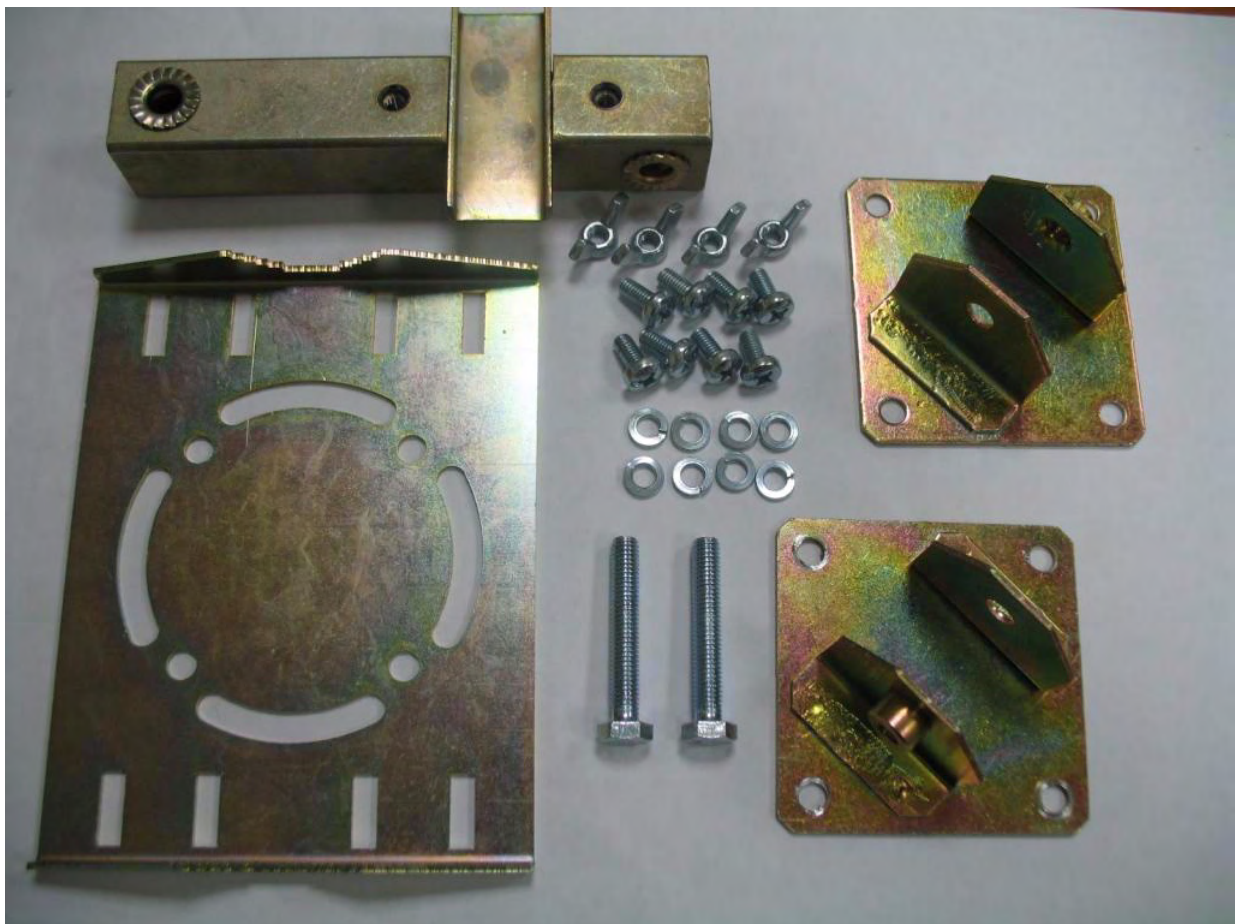

Figure 2-18: MONT-5000-V.Pole-KIT 1



Figure 2-19: MONT-5000-V.Pole-KIT 2

2.6.2 Pole Mounting Kit MONT-5000-H.Pole-KIT for Horizontal Pole

CAUTION



Attention! Pole mounting kit MONT-5000-H.Pole-KIT does NOT contain metal straps.

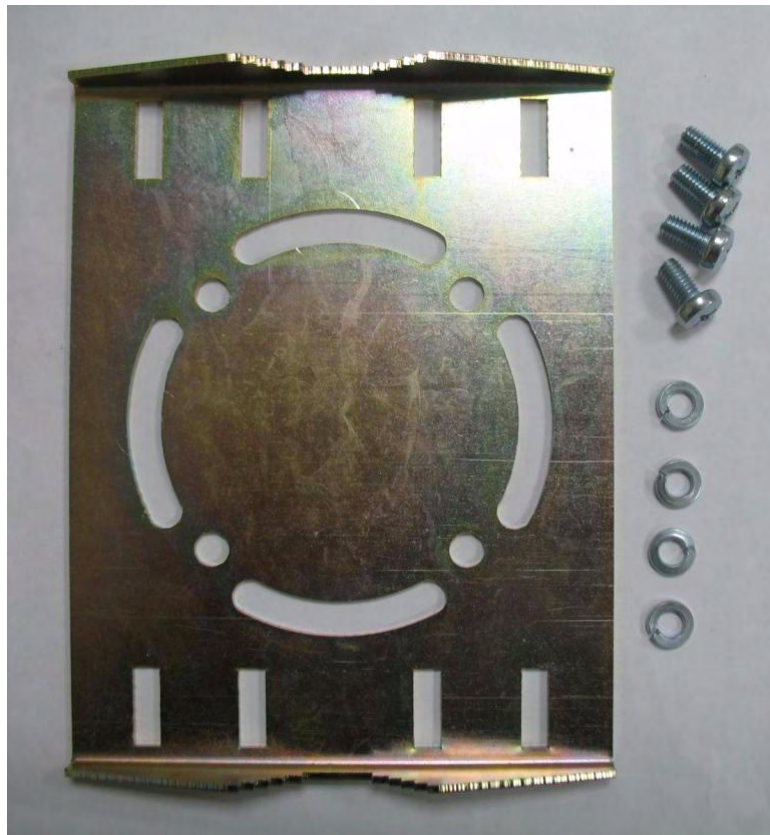

Figure 2-20: MONT-5000-H.Pole-KIT 1



Figure 2-21: MONT-5000-H.Pole-KIT 2

2.7 Specifications

2.7.1 Radio

Table 2-3: Radio Specifications

Item	Description	
Frequency	ETSI (5.470 - 5.725 GHz)	Center frequencies range 5.475 - 5.720 GHz (in 5MHz steps) for 5MHz BW
		Center frequencies range 5.475 - 5.720 GHz (in 5MHz steps) for 10MHz BW
		Center frequencies range 5.480 - 5.700 GHz (in 20MHz steps) for 20MHz BW
		Center frequencies range 5.490 - 5.690 GHz (in 20MHz steps) for 40MHz BW
	ETSI (5.725 - 5.875 GHz)	Center frequencies range 5.730 - 5.870 GHz (in 5MHz steps) for 5MHz BW
		Center frequencies range 5.730 - 5.870 GHz (in 5MHz steps) for 10MHz BW
		Center frequencies range 5.740 - 5.860 GHz (in 20MHz steps) for 20MHz BW
		Center frequencies range 5.750 - 5.850 GHz (in 20MHz steps) for 40MHz BW
	FCC (4.940 - 4.990 GHz)	Center frequencies range 4.945 - 4.985 GHz (in 5MHz steps) for 5MHz BW
		Center frequencies range 4.945 - 4.985 GHz (in 5MHz steps) for 10MHz BW
Center frequencies range 4.960 GHz for 20MHz BW		

Table 2-3: Radio Specifications

Item	Description	
	FCC (5.250 - 5.350 GHz)	Center frequencies range 5.255 - 5.345 GHz (in 5MHz steps) for 5MHz BW
		Center frequencies range 5.255 - 5.345 GHz (in 5MHz steps) for 10MHz BW
		Center frequencies range 5.260 - 5.340 GHz (in 20MHz steps) for 20MHz BW
		Center frequencies range 5.270 - 5.330GHz (in 20MHz steps) for 40MHz BW
	FCC (5.470 - 5.725 GHz)	Center frequencies range 5.475 - 5.720 GHz (in 5MHz steps) for 5MHz BW
		Center frequencies range 5.475 - 5.720 GHz (in 5MHz steps) for 10MHz BW
		Center frequencies range 5.480 - 5.700 GHz (in 20MHz steps) for 20MHz BW
		Center frequencies range 5.490 - 5.690 GHz (in 20MHz steps) for 40MHz BW
	FCC (5.725 - 5.850 GHz)	Center frequencies range 5.730 - 5.845 GHz (in 5MHz steps) for 5MHz BW
		Center frequencies range 5.730 - 5.845 GHz (in 5MHz steps) for 10MHz BW
		Center frequencies range 5.740 - 5.840 GHz (in 20MHz steps) for 20MHz BW
		Center frequencies range 5.750 - 5.830 GHz (in 20MHz steps) for 40MHz BW
	Universal	Center frequencies range 4.915 - 5.945 GHz (in 5MHz steps) for 5MHz BW
Center frequencies range 4.915 - 5.945 GHz (in 5MHz steps) for 10MHz BW		
Center frequencies range 4.920 - 5.940 GHz (in 20MHz steps) for 20MHz BW		
Modulation	OFDM modulation, BPSK, QPSK, QAM16, QAM64	
Radio Type	OFDM TDD	
Channel BW	5 MHz / 10 MHz / 20 MHz	
Maximal Net Throughput	250 Mbps	

Table 2-3: Radio Specifications

Item	Description
Output Power (at antenna port)	Up to 18 dBm (dependant upon regulation)

Table 2-4: Maximum Peak Channel Power Levels

Channel Bandwidth	Max. Total Channel Power (Peak) (dBm)
5 MHz	25.6
10 MHz	24.18
20 MHz	23.58
40 MHz	21.8

2.7.2 Antenna

Table 2-5: Antenna Specifications

Item	Description
External Antenna	ANT, T.S, 4.9-6 GHz, 9°, dual polarized, 23 dBi / ANT, T.S, 4.9-6 GHz, 6°, dual polarized, 28 dBi
Integrated Antenna	ANT, T.S, 4.9-6 GHz, 9°, dual polarized, 23 dBi

2.7.3 Data Communication

Table 2-6: Data Communication Specifications

Item	Description
Standard and Network Compliance	IEEE 802.3 CSMA CD, ARP filter/proxy, MAC/IP filtering, layer 2 switch, 2x Ethernet 10/100BaseT
VLAN Support	802.1q transparent or frame tagging and re-tagging
QoS	QoS enforcer classification and traffic limiting based on: IP ToS/DSCP/802.1p tags, VLAN/IP/MAC address and protocol
Security	Storm/flood protection, password protection, over-the-air payload encryption, IP Firewall

2.7.4 Configuration Management

Table 2-7: Configuration Management Specifications

Item	Description
Management Options	Configure/monitor SNMP traps, WEB interface, CLI (telnet, serial console, remote shell)
Remote Management Access	From wired LAN, wireless link
Allocation of IP Address	DHCP client / server / relay
SW Upgrade	Via FTP / WEB interface
Configuration Upload / Download	Via FTP / WEB interface
SNMP Agents	SNMP V1 / SNMP V3, MIB II, private MIB

2.7.5 Electrical Characteristics

Table 2-8: Electrical Characteristics Specifications

Item	Description
Power Consumption	Up to 20W
Input Power	AC, 100-240 VAC, 50-60 Hz (DC 10.5-32 UDC with OPS-DC add-on module)
Indoor-outdoor Cable	CAT-5 shielded, 90m max
AC Power Indoor Unit	3 pin AC power plug
Connectors	RJ-45

2.7.6 Physical and Environmental

Table 2-9: Physical and Environmental Specifications

Item	Description
Dimensions RB/BU	IDU: 5 x 4 x 2 cm (0.14 kg) / ODU with integrated antenna: 30 x 30 x 8 cm (3.7 kg) / ODU with external antenna 24 x 24 x 5 cm (2.1 kg)
Operating Temperature	ODU: -40°C to 60°C / IDU: 0°C to 40°C
Operating Humidity	ODU: 100% humidity, condensing (exceeds IP65 rating) / IDU: 95% humidity, non-condensing

2.7.7 Standards and Regulations

Table 2-10: Standards and Regulations Compliance

Item	Description
Radio	ETSI EN 301 893 V1.5.1 / ETSI EN 302 502 V1.2.1
EMC	ETSI EN 301 489-1 V1.4.1
Protection and Safety	ETSI EN 60950-1