



**BreezeMAX Series**

**Extreme CPE Manual**

**Extreme CPE  
February 2009  
P/N 149100003100W**

## Document History

| Topic                                | Description | Date Issued   |
|--------------------------------------|-------------|---------------|
| This is the document's first Release |             | February 2009 |

---

## Legal Rights

© Copyright 2008 Alvarion Ltd. All rights reserved.

The material contained herein is proprietary, privileged, and confidential and owned by Alvarion or its third party licensors. No disclosure thereof shall be made to third parties without the express written permission of Alvarion Ltd.

Alvarion Ltd. reserves the right to alter the equipment specifications and descriptions in this publication without prior notice. No part of this publication shall be deemed to be part of any contract or warranty unless specifically incorporated by reference into such contract or warranty.

## Trade Names

Alvarion<sup>®</sup>, BreezeCOM<sup>®</sup>, WALKair<sup>®</sup>, WALKnet<sup>®</sup>, BreezeNET<sup>®</sup>, BreezeACCESS<sup>®</sup>, BreezeMANAGE<sup>™</sup>, BreezeLINK<sup>®</sup>, BreezeConfig<sup>™</sup>, BreezeMAX<sup>™</sup>, AlvariSTAR<sup>™</sup>, AlvariCRAFT<sup>™</sup>, BreezeLITE<sup>™</sup>, MGW<sup>™</sup>, eMGW<sup>™</sup> and/or other products and/or services referenced here in are either registered trademarks, trademarks or service marks of Alvarion Ltd.

All other names are or may be the trademarks of their respective owners.

## Statement of Conditions

The information contained in this manual is subject to change without notice. Alvarion Ltd. shall not be liable for errors contained herein or for incidental or consequential damages in connection with the furnishing, performance, or use of this manual or equipment supplied with it.

## Warranties and Disclaimers

All Alvarion Ltd. ("Alvarion") products purchased from Alvarion or through any of Alvarion's authorized resellers are subject to the following warranty and product liability terms and conditions.

## Exclusive Warranty

(a) Alvarion warrants that the Product hardware it supplies and the tangible media on which any software is installed, under normal use and conditions, will be free from significant defects in materials and workmanship for a period of fourteen (14) months from the date of shipment of a given Product to Purchaser (the "Warranty Period"). Alvarion will, at its sole option and as Purchaser's sole remedy, repair or replace any defective Product in accordance with Alvarion's standard R&R procedure.

(b) With respect to the Firmware, Alvarion warrants the correct functionality according to the attached documentation, for a period of fourteen (14) month from

invoice date (the "Warranty Period"). During the Warranty Period, Alvarion may release to its Customers firmware updates, which include additional performance improvements and/or bug fixes, upon availability (the "Warranty"). Bug fixes, temporary patches and/or workarounds may be supplied as Firmware updates.

Additional hardware, if required, to install or use Firmware updates must be purchased by the Customer. Alvarion will be obligated to support solely the two (2) most recent Software major releases.

ALVARION SHALL NOT BE LIABLE UNDER THIS WARRANTY IF ITS TESTING AND EXAMINATION DISCLOSE THAT THE ALLEGED DEFECT IN THE PRODUCT DOES NOT EXIST OR WAS CAUSED BY PURCHASER'S OR ANY THIRD PERSON'S MISUSE, NEGLIGENCE, IMPROPER INSTALLATION OR IMPROPER TESTING, UNAUTHORIZED ATTEMPTS TO REPAIR, OR ANY OTHER CAUSE BEYOND THE RANGE OF THE INTENDED USE, OR BY ACCIDENT, FIRE, LIGHTNING OR OTHER HAZARD.

## Disclaimer

(a) The Software is sold on an "AS IS" basis. Alvarion, its affiliates or its licensors MAKE NO WARRANTIES, WHATSOEVER, WHETHER EXPRESS OR IMPLIED, WITH RESPECT TO THE SOFTWARE AND THE ACCOMPANYING DOCUMENTATION. ALVARION SPECIFICALLY DISCLAIMS ALL IMPLIED WARRANTIES OF MERCHANTABILITY AND FITNESS FOR A PARTICULAR PURPOSE AND NON-INFRINGEMENT WITH RESPECT TO THE SOFTWARE. UNITS OF PRODUCT (INCLUDING ALL THE SOFTWARE) DELIVERED TO PURCHASER HEREUNDER ARE NOT FAULT-TOLERANT AND ARE NOT DESIGNED, MANUFACTURED OR INTENDED FOR USE OR RESALE IN APPLICATIONS WHERE THE FAILURE, MALFUNCTION OR INACCURACY OF PRODUCTS CARRIES A RISK OF DEATH OR BODILY INJURY OR SEVERE PHYSICAL OR ENVIRONMENTAL DAMAGE ("HIGH RISK ACTIVITIES"). HIGH RISK ACTIVITIES MAY INCLUDE, BUT ARE NOT LIMITED TO, USE AS PART OF ON-LINE CONTROL SYSTEMS IN HAZARDOUS ENVIRONMENTS REQUIRING FAIL-SAFE PERFORMANCE, SUCH AS IN THE OPERATION OF NUCLEAR FACILITIES, AIRCRAFT NAVIGATION OR COMMUNICATION SYSTEMS, AIR TRAFFIC CONTROL, LIFE SUPPORT MACHINES, WEAPONS SYSTEMS OR OTHER APPLICATIONS REPRESENTING A SIMILAR DEGREE OF POTENTIAL HAZARD. ALVARION SPECIFICALLY DISCLAIMS ANY EXPRESS OR IMPLIED WARRANTY OF FITNESS FOR HIGH RISK ACTIVITIES.

(b) PURCHASER'S SOLE REMEDY FOR BREACH OF THE EXPRESS WARRANTIES ABOVE SHALL BE REPLACEMENT OR REFUND OF THE PURCHASE PRICE AS SPECIFIED ABOVE, AT ALVARION'S OPTION. TO THE FULLEST EXTENT ALLOWED BY LAW, THE WARRANTIES AND REMEDIES SET FORTH IN THIS AGREEMENT ARE EXCLUSIVE AND IN LIEU OF ALL OTHER

WARRANTIES OR CONDITIONS, EXPRESS OR IMPLIED, EITHER IN FACT OR BY OPERATION OF LAW, STATUTORY OR OTHERWISE, INCLUDING BUT NOT LIMITED TO WARRANTIES, TERMS OR CONDITIONS OF MERCHANTABILITY, FITNESS FOR A PARTICULAR PURPOSE, SATISFACTORY QUALITY, CORRESPONDENCE WITH DESCRIPTION, NON-INFRINGEMENT, AND ACCURACY OF INFORMATION GENERATED. ALL OF WHICH ARE EXPRESSLY DISCLAIMED. ALVARION' WARRANTIES HEREIN RUN ONLY TO PURCHASER, AND ARE NOT EXTENDED TO ANY THIRD PARTIES. ALVARION NEITHER ASSUMES NOR AUTHORIZES ANY OTHER PERSON TO ASSUME FOR IT ANY OTHER LIABILITY IN CONNECTION WITH THE SALE, INSTALLATION, MAINTENANCE OR USE OF ITS PRODUCTS.

### Limitation of Liability

(a) ALVARION SHALL NOT BE LIABLE TO THE PURCHASER OR TO ANY THIRD PARTY, FOR ANY LOSS OF PROFITS, LOSS OF USE, INTERRUPTION OF BUSINESS OR FOR ANY INDIRECT, SPECIAL, INCIDENTAL, PUNITIVE OR CONSEQUENTIAL DAMAGES OF ANY KIND, WHETHER ARISING UNDER BREACH OF CONTRACT, TORT (INCLUDING NEGLIGENCE), STRICT LIABILITY OR OTHERWISE AND WHETHER BASED ON THIS AGREEMENT OR OTHERWISE, EVEN IF ADVISED OF THE POSSIBILITY OF SUCH DAMAGES.

(b) TO THE EXTENT PERMITTED BY APPLICABLE LAW, IN NO EVENT SHALL THE LIABILITY FOR DAMAGES HEREUNDER OF ALVARION OR ITS EMPLOYEES OR AGENTS EXCEED THE PURCHASE PRICE PAID FOR THE PRODUCT BY PURCHASER, NOR SHALL THE AGGREGATE LIABILITY FOR DAMAGES TO ALL PARTIES REGARDING ANY PRODUCT EXCEED THE PURCHASE PRICE PAID FOR THAT PRODUCT BY THAT PARTY (EXCEPT IN THE CASE OF A BREACH OF A PARTY'S CONFIDENTIALITY OBLIGATIONS).

### Electronic Emission Notices

This equipment has been tested and found to comply with the limits for a Class B digital device, pursuant to Part 15 of the FCC Rules. These limits are designed to provide reasonable protection against harmful interference in a residential installation. This equipment generates, uses and can radiate radio frequency energy and, if not installed and used in accordance with the instructions, may cause harmful interference to radio communications. However, there is no guarantee that interference will not occur in a particular installation. If this equipment does cause harmful interference to radio or television reception, which can be determined by turning the equipment off and on, the user is encouraged to try to correct the interference by one of the following measures:

- -Reorient or relocate the receiving antenna.

- -Increase the separation between the equipment and receiver.
- -Connect the equipment into an outlet on a circuit different from that to which the receiver is connected.
- -Consult the dealer or an experienced radio/TV technician for help.

Operation is subject to the following two conditions:

- 1 This device may not cause harmful interference.
- 2 This device must accept any interference received, including interference that may cause undesired operation.

## Radio Frequency Interference Statement

The Extreme CPE Access Unit has been tested and found to comply with the limits for a class B digital device, pursuant to part 15 of the FCC rules and to EN 301 489-1 rules. These limits are designed to provide reasonable protection against harmful interference when the equipment is operated in a residential environment notwithstanding use in commercial, business and industrial environments. This equipment generates, uses, and can radiate radio frequency energy and, if not installed and used in accordance with the instruction manual, may cause harmful interference to radio communications.

## FCC Radiation Hazard Warning

To comply with FCC RF exposure requirement, the antenna used for this equipment must be fixed-mounted on outdoor permanent structures with a separation distance of at least 62 centimeters (25 inches) from all persons.

## R&TTE Compliance Statement

This equipment complies with the appropriate essential requirements of Article 3 of the R&TTE Directive 1999/5/EC.

This device is intended for use in the following European Community and EFTA countries:

|                   |  |
|-------------------|--|
| Czech<br>Česky    | Accton tímto prohlašuje, že tento Radio LAN je ve shodě se základními požadavky a dalšími příslušnými ustanoveními směrnice 1999/5/ES.                           |
| Estonian<br>Eesti | Käesolevaga kinnitab Accton seadme Radio LAN vastavust direktiivi 1999/5/EÜ põhinõuetele ja nimetatud direktiivist tulenevatele teistele asjakohastele sätetele. |
| English           | Hereby, Accton, declares that this Radio LAN device is in compliance with the essential requirements and other relevant provisions of Directive 1999/5/EC.       |

|                                |   |
|--------------------------------|---|
| Finnish<br><i>Suomi</i>        | Valmistaja Accton vakuuttaa täten että Radio LAN device tyyppinen laite on direktiivin 1999/5/EY oleellisten vaatimusten ja sitä koskevien direktiivin muiden ehtojen mukainen.   |
| Dutch<br><i>Nederlands</i>     | Hierbij verklaart Accton dat het toestel Radio LAN device in overeenstemming is met de essentiële eisen en de andere relevante bepalingen van richtlijn 1999/5/EG<br><br>Bij deze Accton dat deze Radio LAN device voldoet aan de essentiële eisen en aan de overige relevante bepalingen van Richtlijn 1999/5/EC.  |
| French<br><i>Français</i>      | Par la présente Accton déclare que l'appareil Radio LAN device est conforme aux exigences essentielles et aux autres dispositions pertinentes de la directive 1999/5/CE   |
| Swedish<br><i>Svenska</i>      | Härmed intygar Accton att denna Radio LAN device står i överensstämmelse med de väsentliga egenskapskrav och övriga relevanta bestämmelser som framgår av direktiv 1999/5/EG.   |
| Danish<br><i>Dansk</i>         | Undertegnede Accton erklærer herved, at følgende udstyr Radio LAN device overholder de væsentlige krav og øvrige relevante krav i direktiv 1999/5/EF  |
| German<br><i>Deutsch</i>       | Hiermit erklärt Accton, dass sich dieser/diese/dieses Radio LAN device in Übereinstimmung mit den grundlegenden Anforderungen und den anderen relevanten Vorschriften der Richtlinie 1999/5/EG befindet". (BMW)<br><br>Hiermit erklärt Accton die Übereinstimmung des Gerätes Radio LAN device mit den grundlegenden Anforderungen und den anderen relevanten Festlegungen der Richtlinie 1999/5/EG. (Wien) |
| Greek<br><i>ελληνικά</i>       | Με την παρουσία Accton δηλώνει ότι radio LAN device συμμορφώνεται προς τις ουσιαστικές απαιτήσεις και τις λοιπές σχετικές διατάξεις της οδηγίας 1999/5/εκ   |
| Hungarian<br><i>Magyar</i>     | Alulírott, Accton nyilatkozom, hogy a Radio LAN megfelel a vonatkozó alapvető követelményeknek és az 1999/5/EC irányelv egyéb előírásainak.   |
| Italian<br><i>Italiano</i>     | Con la presente Accton dichiara che questo Radio LAN device è conforme ai requisiti essenziali ed alle altre disposizioni pertinenti stabilite dalla direttiva 1999/5/CE.   |
| Latvian<br><i>Latviski</i>     | Ar šo Accton deklarē, ka Radio LAN atbilst Direktīvas 1999/5/EK būtiskajām prasībām un citiem ar to saistītajiem noteikumiem.   |
| Lithuanian<br><i>Lietuvių</i>  | Šiuo [manufacturer name] deklaruojama, kad šis [equipment type] atitinka esminius reikalavimus ir kitas 1999/5/EB Direktyvos nuostatas.   |
| Maltese<br><i>Malti</i>        | Hawnhekk, Accton, jiddikjara li dan Radio LAN jikkonforma mal-ħtiġijiet essenzjali u ma provvedimenti oħrajn relevanti li hemm fid-Dirrettiva 1999/5/EC.  |
| Spanish<br><i>Español</i>      | Por medio de la presente Accton declara que el Radio LAN device cumple con los requisitos esenciales y cualesquiera otras disposiciones aplicables o exigibles de la Directiva 1999/5/CE  |
| Polish<br><i>Polski</i>        | Niniejszym Accton oświadcza, że Radio LAN jest zgodny z zasadniczymi wymogami oraz pozostałymi stosownymi postanowieniami Dyrektywy 1999/5/EC.  |
| Portuguese<br><i>Português</i> | Accton declara que este Radio LAN device está conforme com os requisitos essenciais e outras disposições da Directiva 1999/5/CE.  |

|                               |   |
|-------------------------------|---|
| Slovak<br><i>Slovensky</i>    | Accton týmto vyhlasuje, že Radio LAN spĺňa základné požiadavky a všetky príslušné ustanovenia Smernice 1999/5/ES.           |
| Slovenian<br><i>Slovensko</i> | Accton izjavlja, da je ta Radio LAN v skladu z bistvenimi zahtevami in ostalimi relevantnimi doložiili direktive 1999/5/ES. |

## Caution

To avoid electrical shock, do not perform any servicing unless you are qualified to do so.

## Line Voltage

Before connecting this instrument to the power line, make sure that the voltage of the power source matches the requirements of the instrument. The unit must be connected to an earthed (grounded) outlet to comply with international safety standards.

## Radio

The instrument transmits radio energy during normal operation. To avoid possible harmful exposure to this energy, do not stand or work for extended periods of time in front of its antenna. The long-term characteristics or the possible physiological effects of Radio Frequency Electromagnetic fields have not been yet fully investigated.

## Outdoor Unit and Antenna Installation and Grounding

Ensure that outdoor units, antennas and supporting structures are properly installed to eliminate any physical hazard to either people or property. Make sure that the installation of the outdoor unit, antenna and cables is performed in accordance with all relevant national and local building and safety codes. Even where grounding is not mandatory according to applicable regulation and national codes, it is highly recommended to ensure that the outdoor unit and the antenna mast (when using external antenna) are grounded and suitable lightning protection devices are used so as to provide protection against voltage surges and static charges. In any event, Alvarion is not liable for any injury, damage or regulation violations associated with or caused by installation, grounding or lightning protection.

## Disposal of Electronic and Electrical Waste



### Disposal of Electronic and Electrical Waste

Pursuant to the WEEE EU Directive electronic and electrical waste must not be disposed of with unsorted waste. Please contact your local recycling authority for disposal of this product.



| <b>《电子信息产品污染控制管理办法》<br/>(第39号)<br/>(又名中国RoHS)</b>   |           |           |           |                            |               |                  |
|---|-----------|-----------|-----------|----------------------------|---------------|------------------|
| 产品内含危害物质揭露表   |           |           |           |                            |               |                  |
| 零部件名称   | 危害物质项目    |           |           |                            |               |                  |
|   | 铅<br>(Pb) | 镉<br>(Cd) | 汞<br>(Hg) | 六价铬<br>(Cr <sup>6+</sup> ) | PBB<br>(多溴联苯) | PBDE<br>(多溴二苯乙醚) |
| 含铜线材  | ×         | ○         | ○         | ○                          | ○             | ○                |
| 连接器   | ×         | ○         | ○         | ○                          | ○             | ○                |
| 变压器   | ×         | ○         | ○         | ○                          | ○             | ○                |
| 陶瓷电容  | ×         | ○         | ○         | ○                          | ○             | ○                |
| 高温锡材  | ×         | ○         | ○         | ○                          | ○             | ○                |
| ○：表示此部件使用的所有同类材料中此种有毒或有害物质的含量均低于 SJ/T11363-2006 规定的限制要求。<br>×：表示此部件使用的至少一种同类材料中，此种有毒或有害物质的含量高于 SJ/T11363-2006 规定的限制要求。  |           |           |           |                            |               |                  |
| The above table provides information required under the following Chinese legislation:<br><b>Management methods for Controlling Pollution by Electronic Information Products(No.39)</b><br>(also known as China RoHS) |           |           |           |                            |               |                  |

## Important Notice

This user manual is delivered subject to the following conditions and restrictions:

- This manual contains proprietary information belonging to Alvarion Ltd. Such information is supplied solely for the purpose of assisting properly authorized users of the respective Alvarion products.
- No part of its contents may be used for any other purpose, disclosed to any person or firm or reproduced by any means, electronic and mechanical, without the express prior written permission of Alvarion Ltd.
- The text and graphics are for the purpose of illustration and reference only. The specifications on which they are based are subject to change without notice.
- The software described in this document is furnished under a license. The software may be used or copied only in accordance with the terms of that license.
- Information in this document is subject to change without notice.
- Corporate and individual names and data used in examples herein are fictitious unless otherwise noted.
- Alvarion Ltd. reserves the right to alter the equipment specifications and descriptions in this publication without prior notice. No part of this publication shall be deemed to be part of any contract or warranty unless specifically incorporated by reference into such contract or warranty.
- The information contained herein is merely descriptive in nature, and does not constitute an offer for the sale of the product described herein.
- Any changes or modifications of equipment, including opening of the equipment not expressly approved by Alvarion Ltd. will void equipment warranty and any repair thereafter shall be charged for. It could also void the user's authority to operate the equipment.

Some of the equipment provided by Alvarion and specified in this manual, is manufactured and warranted by third parties. All such equipment must be installed and handled in full compliance with the instructions provided by such manufacturers as attached to this manual or provided thereafter by Alvarion or

the manufacturers. Non-compliance with such instructions may result in serious damage and/or bodily harm and/or void the user's authority to operate the equipment and/or revoke the warranty provided by such manufacturer.





# About This Manual

This manual describes the Extreme CPE and details how to install, operate and manage it.

This manual is intended for technicians responsible for installing, setting and operating the BreezeMAX Extreme CPE system, and for system administrators responsible for managing the system.

This manual contains the following chapters and appendices:

- **Chapter 1 - Product Description** - Describes the Extreme CPE unit and its functionality.
- **Chapter 2 - Installation** - Describes how to install the Extreme CPE and how to connect to subscriber's equipment.
- **Chapter 3 - Initial Configuration** - Describes how to initially configure the Extreme CPE in order to test basic link operation.
- **Chapter 4 - System Settings** - Describes general management functions for the Extreme CPE.
- **Chapter 5 - Unit Control** - Describes management functions for the operation of the Ethernet port, software version and configuration of password.
- **Chapter 6 - Registration** - Describes the manner in which the Extreme CPE can be described to identify itself on a network.
- **Chapter 7 - BS Scanning** - Describes the manner in which the access unit can interoperate with the base station.
- **Chapter 8 - ATPC** - Describes the functions of the adaptive transmission power control (ATPC) algorithm.
- **Chapter 9 - Performance Monitor** - Describes the performance statistics for all aspects of the Ethernet link and WiMAX connection.

- **Chapter 10 - Service** - Describes the configuration of VLANs and DSCP parameters.
- **Chapter 11 - Management** - Describes system management statistics.
- **Chapter 12 - Logout** - Describes logging out of the system.
- **Appendix A - GNU License**
- **Glossary** - Glossary of terms used in the Extreme CPE User Guide.



# Contents

## Chapter 1 - Product Description

|  |          |
|--|----------|
| <b>1.1 Introducing the Extreme CPE range</b> ..... | <b>2</b> |
| 1.1.1 The Extreme CPE range of products .....      | 3        |
| <b>1.2 Specifications</b> .....                    | <b>4</b> |
| 1.2.1 WiMAX Radio .....                            | 4        |
| 1.2.2 VoIP Specifications .....                    | 5        |
| 1.2.3 Configuration and Management .....           | 6        |
| 1.2.4 Mechanical IDU .....                         | 6        |
| 1.2.5 Mechanical ODU .....                         | 6        |
| 1.2.6 Electrical.....                              | 7        |
| 1.2.7 Environmental IDU .....                      | 7        |
| 1.2.8 Environmental ODU .....                      | 7        |
| 1.2.9 Standards Compliance .....                   | 8        |

## Chapter 2 - Hardware Installation

|  |           |
|--|-----------|
| <b>2.1 Installation Requirements</b> ..... | <b>12</b> |
| 2.1.1 Packings List .....                  | 12        |
| <b>2.2 ODU Hardware Description</b> .....  | <b>13</b> |
| 2.2.1 Built-in WiMAX Antenna .....         | 13        |
| 2.2.2 Propriety Ethernet RJ-45 Port .....  | 13        |
| 2.2.3 SAU Port .....                       | 13        |
| 2.2.4 Weatherproof Port Covers .....       | 14        |
| 2.2.5 Ground Screw .....                   | 15        |
| 2.2.6 Pole-Mounting Bracket Kit.....       | 16        |

|  |   |           |
|--|---|-----------|
| 2.2.7                                    | Tilt-Mount Bracket (Optional) .....               | 16        |
| 2.2.8                                    | SAU (Optional) .....                              | 17        |
| <b>2.3</b>                               | <b>IDU Hardware Description .....</b>             | <b>19</b> |
| 2.3.1                                    | 10BASE-T/100BASE-TX LAN Port .....                | 20        |
| 2.3.2                                    | ODU Port.....                                     | 20        |
| 2.3.3                                    | System Status LEDs .....                          | 21        |
| 2.3.4                                    | Power Adapter Socket .....                        | 21        |
| 2.3.5                                    | Backup Battery Charger (Optional) .....           | 21        |
| <b>2.4</b>                               | <b>Installation Steps.....</b>                    | <b>22</b> |
| <b>2.5</b>                               | <b>ODU Installation .....</b>                     | <b>23</b> |
| 2.5.1                                    | ODU Location.....                                 | 23        |
| 2.5.2                                    | Mount the Unit.....                               | 23        |
| <b>2.6</b>                               | <b>IDU Installation .....</b>                     | <b>26</b> |
| 2.6.1                                    | Select a location .....                           | 26        |
| 2.6.2                                    | Installing the unit .....                         | 26        |
| <b>2.7</b>                               | <b>ODU Cable Connection.....</b>                  | <b>28</b> |
| 2.7.1                                    | ODU-IDU Propriety Ethernet Cable Connection ..... | 28        |
| 2.7.2                                    | ODU 10 PIN Ethernet Port .....                    | 30        |
| 2.7.3                                    | Propriety 10 Pin Assignments .....                | 30        |
| <b>2.8</b>                               | <b>IDU Data Port .....</b>                        | <b>36</b> |
| 2.8.1                                    | 10/100BASE-TX Pin Assignments .....               | 36        |
| 2.8.2                                    | Extreme CPE Cables .....                          | 38        |
| <b>2.9</b>                               | <b>ODU Antenna Alignment .....</b>                | <b>40</b> |
| 2.9.1                                    | Align the WiMAX Antenna.....                      | 41        |
| <br>                                     |   |           |
| <b>Chapter 3 - Initial Configuration</b> |   |           |
| <b>3.1</b>                               | <b>Introduction .....</b>                         | <b>44</b> |



---

|  |           |
|--|-----------|
| 3.1.1 Accessing the Web Management Interface ..... | 44        |
| <b>Chapter 4 - System Settings</b>                 |           |
| <b>4.1 Introduction .....</b>                      | <b>48</b> |
| <b>4.2 System Status.....</b>                      | <b>49</b> |
| <b>Chapter 5 - Unit Control</b>                    |           |
| <b>5.1 Introduction .....</b>                      | <b>56</b> |
| <b>5.2 Show Unit Control .....</b>                 | <b>57</b> |
| <b>5.3 Reset.....</b>                              | <b>61</b> |
| <b>5.4 Change Password .....</b>                   | <b>62</b> |
| <b>5.5 Software Version Control .....</b>          | <b>63</b> |
| <b>5.6 Configuration Control .....</b>             | <b>65</b> |
| <b>5.7 TM and PM File Upload Control .....</b>     | <b>67</b> |
| <b>5.8 Ethernet Operation Mode .....</b>           | <b>68</b> |
| <b>Chapter 6 - Registration</b>                    |           |
| <b>6.1 Introduction .....</b>                      | <b>70</b> |
| <b>6.2 Show Registration Parameters .....</b>      | <b>71</b> |
| <b>6.3 Registration Configuration.....</b>         | <b>72</b> |
| <b>Chapter 7 - Base Station Scanning</b>           |           |
| <b>7.1 Introduction .....</b>                      | <b>74</b> |
| <b>7.2 BS Scanning .....</b>                       | <b>75</b> |
| <b>Chapter 8 - Radio Parameters</b>                |           |
| <b>8.1 Introduction .....</b>                      | <b>80</b> |
| <b>8.2 Radio Parameters.....</b>                   | <b>81</b> |
| <b>8.3 Frequency Scanning.....</b>                 | <b>82</b> |
| <b>8.4 Antenna Selection .....</b>                 | <b>85</b> |

[Chapter 9 - ATPC](#)

**9.1 Introduction ..... 88**  
**9.2 ATPC Parameters ..... 89**  
**9.3 ATPC Configuration ..... 90**

[Chapter 10 - Performance Monitor](#)

**10.1 Introduction ..... 94**  
**10.2 Link Quality Counters ..... 95**  
**10.3 Ethernet Counters ..... 97**  
**10.4 Link Historical ..... 99**  
**10.5 Ethernet Historical ..... 101**  
**10.6 Integration Time ..... 104**  
**10.7 Spectrum Analyzer ..... 105**

[Chapter 11 - Service](#)

**11.1 Introduction ..... 108**  
**11.2 Show Service ..... 109**  
**11.3 Service Parameters ..... 110**

[Chapter 12 - Management](#)

**12.1 Introduction ..... 112**  
**12.2 Management Parameters ..... 113**

[Chapter 13 - Logout](#)

**13.1 Logout ..... 116**

[Appendix A - Troubleshooting](#)

[Appendix B - GNU License](#)

**B.1 The GNU General Public License ..... 122**  
    B.1.1 Preamble ..... 123  
    B.1.2 GNU GENERAL PUBLIC LICENSE TERMS AND CONDITIONS FOR COPYING,

DISTRIBUTION AND MODIFICATION 124



---

## Chapter 1 - Product Description

### In This Chapter:

- “Introducing the Extreme CPE range” on page 2
- “The Extreme CPE range of products” on page 3
- “Specifications” on page 4

## 1.1 Introducing the Extreme CPE range

Extreme CPE is a set of outdoor (ODU) units with an indoor component (IDU), that are either 2.3 GHz, 2.5GHz, 3.5 GHz, or 5 GHz, high capacity gateways and WiMAX Wireless Broadband Access subscriber stations, for a home or small office. Which ODU set you use depends on the frequency band of your service provider's WiMAX service. Each system provides network connections that are always on, supporting immediate access to the Internet and other IP services at high data rates. The unit provides a gateway function between a WiMAX service provider and a local Ethernet LAN. The device enables a service provider to deliver last mile broadband wireless access as an alternative to wired DSL or cable modems.

Part of an extended and field-proven product portfolio, Extreme CPE is an integral part of the Extreme family, the latest most technologically advanced wireless solution for broadband deployment. With capacity of up to 20 Mbps download and 7 Mbps upload speed per unit, the Extreme CPE solution enables the delivery of powerful wireless broadband services to the subscriber. Extreme CPE is an out-of-the-box solution with immediate available local stock enabling virtually instant network expansion and simplified deployment. Extreme CPE provides a wireless solution for the subscriber to connect to the internet.

With a range of up to 5 Km and lower equipment and deployment costs, Extreme CPE enables service providers to wirelessly extend their services to customers in areas where the cost of cabling is prohibitive to deployment. Remote residential areas can now benefit from high-speed wireless Internet access, Web browsing and e-mail, and advanced applications such as multi-media services.

The Extreme CPE indoor unit (IDU) is a plug-and-play device that provides PoE power to the ODU and a network interface through an RJ-45 Ethernet switch port, as well as two RJ-11 Voice over IP (VoIP) phone ports for telecommunications.

## 1.1.1 The Extreme CPE range of products

The following table lists the available Extreme CPE models:

**Table 1-1: Extreme CPE Range of Models**

| Frequency Band | Model Number | Description                                |
|----------------|--------------|--|
| 2.3 GHz        |              | ■ 1 RJ-45 data port                        |
|                |              | ■ 1 RJ-45 data port and 2 RJ-11 VoIP ports |
| 2.5 GHz        |              | ■ 1 RJ-45 data port                        |
|                |              | ■ 1 RJ-45 data port and 2 RJ-11 VoIP ports |
| 3.5 GHz        |              | ■ 1 RJ-45 data port                        |
|                |              | ■ 1 RJ-45 data port and 2 RJ-11 VoIP ports |
| 5 GHz          |              | ■ 1 RJ-45 data port                        |
|                |              | ■ 1 RJ-45 data port and 2 RJ-11 VoIP ports |

The Extreme CPE offers a user-friendly web-based management interface for the configuration of all the unit's features. Any PC directly attached to the unit can access the management interface using a web browser, such as Internet Explorer (version 6.0 or above) or Firefox (version 1.5 or above).

The initial configuration steps can be made through the web browser interface using the Setup Wizard. It is recommended to make the initial changes by connecting a PC directly to one of the Extreme's LAN ports.

## 1.2 Specifications

### 1.2.1 WiMAX Radio

**Table 1-2: WiMAX Radio Specifications**

| Item                              | Description  |
|-----------------------------------|--|
| <b>Radio Type</b>                 | IEEE 802.16e WAVE 1 & WAVE 2   |
| <b>Frequency Band Range</b>       | <ul style="list-style-type: none"> <li>■ 2305-2360 MHz, or</li> <li>■ 2496-2690 MHz, or</li> <li>■ 3400-3600 MHz, or</li> <li>■ 4900-5950 MHz</li> </ul>   |
| <b>Antenna Type (ODU)</b>         | ■ Integrated Flat Panel Antenna, 17dBi, 24°AZ x 18°EL.   |
| <b>Channel Bandwidth</b>          | 5.00, 7.00, 8.75, and 10.00 MHz  |
| <b>Maximum Throughput</b>         | 5 Mbps Upload, 20 Mbps download  |
| <b>Radio Technology</b>           | Maximum-Ratio Combining (MRC)  |
| <b>Modulation Technique</b>       | <ul style="list-style-type: none"> <li>■ Scalable OFDMA employing Time-Division Duplex (TDD) mechanism</li> <li>■ PRBS subcarrier randomization</li> <li>■ Contains pilot, preamble, and ranging modulation</li> </ul> |
| <b>FEC Coding Rates</b>           | <ul style="list-style-type: none"> <li>■ Down Link: QPSK, 16 QAM, 64 QAM</li> <li>■ Up Link: QPSK, 16 QAM</li> </ul>   |
| <b>Antenna Gain</b>               | Flat panel antenna: <ul style="list-style-type: none"> <li>■ 2.3 GHz: 13.5 dBi</li> <li>■ 2.5 GHz: 13.5 dBi</li> <li>■ 3.5 GHz: 15 dBi</li> <li>■ 5 GHz: 17 dBi</li> </ul>   |
| <b>TPL (Transmit Power Level)</b> | +24 dBm maximum  |
| <b>Receive Sensitivity</b>        | -94 dBm maximum  |



## 1.2.2 VoIP Specifications

**Table 1-3: VoIP Specifications**

| Item                                | Description   |
|-------------------------------------|---|
| <b>Voice Signalling Protocol</b>    | SIP v2 (RFC 3261)   |
| <b>Voice Codex</b>                  | <ul style="list-style-type: none"> <li>■ G.711 (a-law and u-law)</li> <li>■ G.729ab</li> <li>■ G.722</li> <li>■ G.722.1</li> </ul>  |
| <b>Voice Quality</b>                | <ul style="list-style-type: none"> <li>■ G.726 VAD (Voice Activity Detection)</li> <li>■ G.723 CNG (Comfortable Noise Generation)</li> <li>■ Echo cancellation (G.165/G.168)</li> <li>■ Adaptive jitter buffer, up to 200 milliseconds</li> <li>■ DTMF tone detection and generation</li> <li>■ Configurable Cadence Rings</li> </ul> |
| <b>Call Features</b>                | <ul style="list-style-type: none"> <li>■ Call transfer</li> <li>■ Call waiting/hold/retrieve</li> <li>■ 3-way conference call</li> <li>■ Call blocking</li> <li>■ T.38 fax relay</li> <li>■ Dial plan (E.164 dialing plan)</li> <li>■ Call forwarding: No Answer/Busy/All</li> </ul>  |
| <b>REN (Ring Equivalent Number)</b> | <ul style="list-style-type: none"> <li>■ 3 REN total in system</li> </ul>   |

## 1.2.3 Configuration and Management

**Table 1-4: Configuration and Management**

| Item                                 | Description  |
|--------------------------------------|--|
| <b>Management options</b>            | <ul style="list-style-type: none"> <li>■ Web-based (HTTP/HTTPS)</li> <li>■ SNMP</li> <li>■ TR-069</li> <li>■ TFTP</li> <li>■ Telnet</li> </ul> |
| <b>SNMP agent</b>                    | V1 / V2c, supports 802.11 MIB, RFC-1213 MIB II and private MIB.  |
| <b>Management access</b>             | From Wired LAN, Wireless Link  |
| <b>Management access protection</b>  | Access Password  |
| <b>Encryption</b>                    | WEP 152-bits   |
| <b>Allocation of IP parameters</b>   | Configurable or automatic (DHCP client)  |
| <b>Software upgrade</b>              | HTTP/FTP/TFTP  |
| <b>Configuration Upload/Download</b> | HTTP   |

## 1.2.4 Mechanical IDU

**Table 1-5: Mechanical Specifications**

| Item              | Description                     |
|-------------------|---------------------------------|
| <b>Dimensions</b> | 156mm (L) X 60mm (W) X 33mm (T) |
| <b>Weight</b>     | 0.32kg                          |
| <b>Mounting</b>   | Desktop                         |
| <b>Cabling</b>    | Category 5 cable connection     |

## 1.2.5 Mechanical ODU

**Table 1-6: Mechanical Specifications**

| Item              | Description                       |
|-------------------|-----------------------------------|
| <b>Dimensions</b> | 230mm (H) X 230mm (W) X 63 (T) mm |
| <b>Weight</b>     | 2kg                               |
| <b>Mounting</b>   | Pole-mount                        |
| <b>Cabling</b>    | Category 5 cable connection       |

## 1.2.6 Electrical

The Extreme CPE provides two types of power supply with charger and without charger capability. The charger provides optional battery backup features for areas that have no PSTN service but do need to comply with emergency laws for VoIP service. The backup battery supply is not available in this release.

**Table 1-7: Electrical Specifications**

| Type                   | Details  |
|------------------------|--|
| <b>AC Power Supply</b> | Input: 100-240 VAC, 50-60 Hz, maximum power consumption 0.5A<br>Output: 55 VDC, maximum power consumption 1A |
| <b>MTBF</b>            | <ul style="list-style-type: none"> <li>■ 200,000 hrs</li> <li>■ Bellcore SR332</li> </ul>                    |

## 1.2.7 Environmental IDU

**Table 1-8: Environmental Specifications**

| Item                         | Details                      |
|------------------------------|------------------------------|
| <b>Operating Temperature</b> | -5°C to 45°C                 |
| <b>Storage Temperature</b>   | -40 to 75 °C                 |
| <b>Humidity</b>              | Maximum 95%, non-condensing. |

## 1.2.8 Environmental ODU

**Table 1-9: Environmental Specifications**

| Item                         | Details   |
|------------------------------|---|
| <b>Operating Temperature</b> | -40°C to 55°C   |
| <b>Storage Temperature</b>   | -40 to 70 °C  |
| <b>Humidity</b>              | Maximum 95%, non-condensing.                            |
| <b>Rain</b>                  | IEC 68-2-18 method 2.2                                  |
| <b>Random Vibration</b>      | IEC 68-2-64   |
| <b>Shock</b>                 | IEC-68-2-29   |
| <b>Salt Fog</b>              | IEC-68-2-11   |
| <b>Ice Loading</b>           | 25mm radial ice density 7kN/m3                          |
| <b>Solar Radiation</b>       | IEC-68-2-5, MIL-STD-810D                                |
| <b>Wind Speed</b>            | 160Km/Hr required for antenna stability under operation |

## 1.2.9 Standards Compliance

**Table 1-10: Standards Compliance**

| Type                                    | Standard  |
|---|---|
| <b>EMC</b>                              | <ul style="list-style-type: none"> <li>■ FCC Part 15B Class B</li> <li>■ EN 55022 Class B</li> <li>■ EN 61000-3-2</li> <li>■ EN 61000-3-3</li> <li>■ EN 301 489-1/4</li> </ul>            |
| <b>Safety</b>                           | <ul style="list-style-type: none"> <li>■ UL 60950-1/-22</li> <li>■ IEC/EN 60950-1/-22</li> </ul>  |
| <b>Immunity</b>                         | <ul style="list-style-type: none"> <li>■ EN 61000-4-2/3/4/6/11</li> <li>■ ITU-T K21</li> </ul>  |
| <b>WiMAX Radio Signal Certification</b> | <ul style="list-style-type: none"> <li>■ EN 302 326, EN 302 326-1, EN 302 326-3, EN 301 893, EN 302 502</li> <li>■ FCCp15.407 , p15.247, p.27</li> <li>■ ETSI/EN-301753 V1.1.1</li> </ul> |
| <b>Standards</b>                        | <ul style="list-style-type: none"> <li>■ IEEE 802.16e-2005 WAVE 1 and WAVE 2</li> <li>■ IEEE 802.3-2005 10BASE-T and 100BASE-TX</li> </ul>  |





---

## Chapter 2 - Hardware Installation

### In This Chapter:

- “Installation Requirements” on page 12
- “Packings List” on page 12
- “ODU Hardware Description” on page 13
- “IDU Hardware Description” on page 20
- “Installation Steps” on page 23
- “ODU Installation” on page 24
- “IDU Installation” on page 28
- “ODU Cable Connection” on page 30
- “Propriety 10 Pin Assignments” on page 32
- “IDU Data Port” on page 38
- “ODU Antenna Alignment” on page 42
- “Align the WiMAX Antenna” on page 43

## 2.1 Installation Requirements

This section describes how to install and connect the Extreme CPE WiMAX Residential Gateway.

### 2.1.1 Packings List

The BreezeMAX K2 CPE is split into four separate packages which include the following components:

- BreezeMAX K2 CPE ODU unit with integrated antennas\*
- Extreme CPE IDU unit, comprising of AC power adapter and internal gateway
- ODU pole mount bracket kit
- Propriety 10 PIN RJ-45 Category 5 network cable (90m)
- Software Utilities and User Guide CD

\*For the bandwidth specification of your choice of model see [“The Extreme CPE range of products” on page 3](#)

Optional:

- Backup power supply.
- Tilt mount bracket.
- SAU



## 2.2 ODU Hardware Description

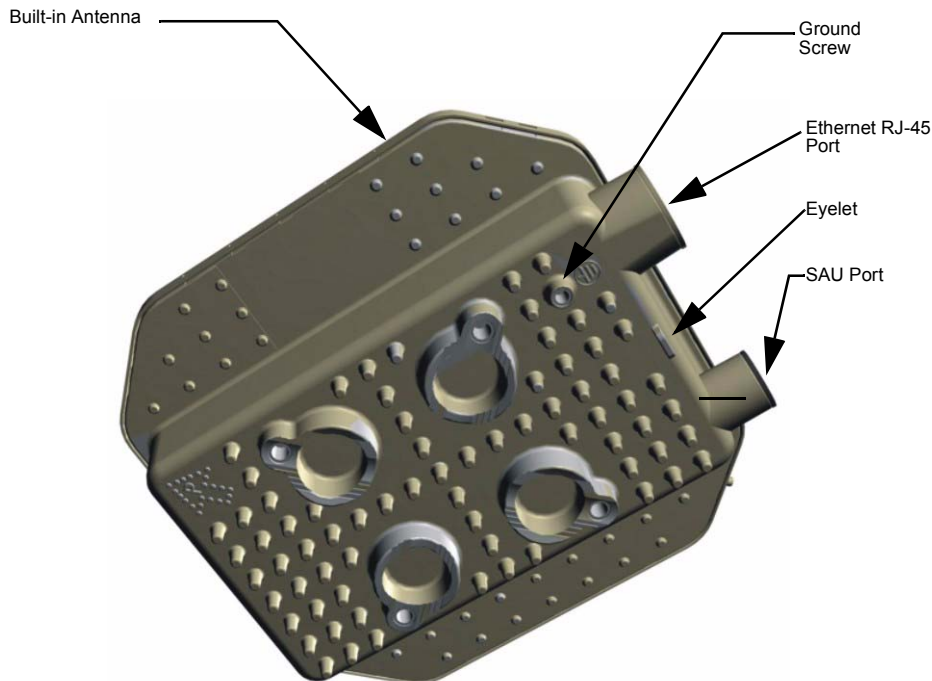

### 2.2.1 Built-in WiMAX Antenna

One high-gain internal antenna is built into the ODU for WiMAX communications. The antenna must be aligned towards the direction of the WiMAX service provider's base station.

### 2.2.2 Propriety Ethernet RJ-45 Port

The ODU has one propriety 10 PIN RJ-45 PoE port that connects to the IDU using Ethernet cable. The Ethernet port connection provides power to the ODU as well as a data link to the IDU.

#### CAUTION



Do not connect a standard RJ-45 Category 5e cable to the ODU port or your unit will not function correctly. Use only the provided propriety 10 PIN Ethernet cable with 10 PIN plug adapters.

### 2.2.3 SAU Port

A Subscriber Unit Alignment Unit (SAU) port is included for connecting an optional SAU device that provides indicator status LEDs for antenna alignment.

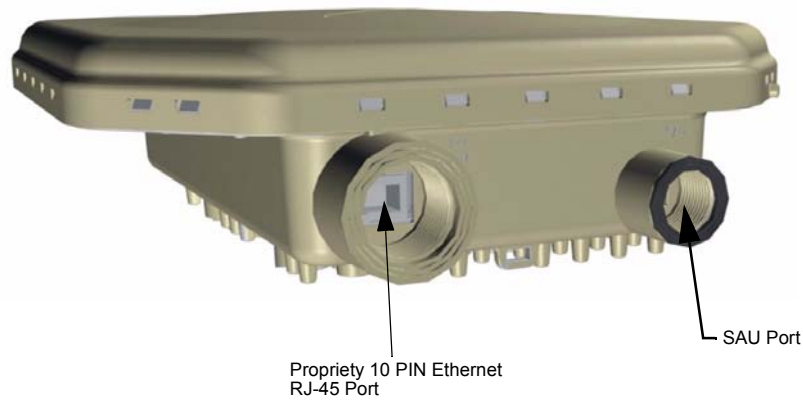

## 2.2.4 Weatherproof Port Covers

The ODU includes rubber weatherproof port covers for the RJ-45 and SAU ports. The RJ-45 port cover allows the Ethernet cable to be fed through and connected to the RJ-45 port. The SAU port cover protects the SAU port when it is not in use and its rubber chord should be threaded through the eyelet on the ODU to prevent loss of the cover when unscrewing and attaching an SAU.

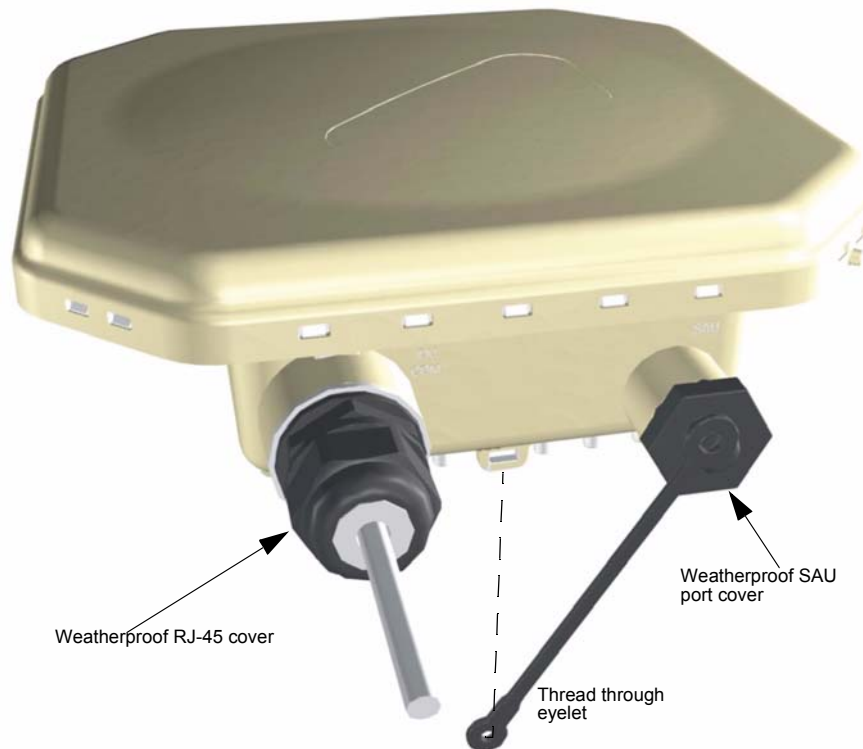

## 2.2.5 Ground Screw

The ODU includes its own built-in lightning protection, it is important that the unit is properly connected to ground. A grounding screw is provided for attaching a ground wire to the unit.



**To ground the unit please follow the guidelines below:**

- Be sure to use #14 AWG category cable to ground the unit.
- The unit can be grounded to the bracket or to the pole, alternatively you can ground the unit straight to earth.
- If grounding to the bracket or the pole make sure that you attach the grounding wire to a non-painted exposed part of either. Subsequently make sure that the pole is grounded to earth.

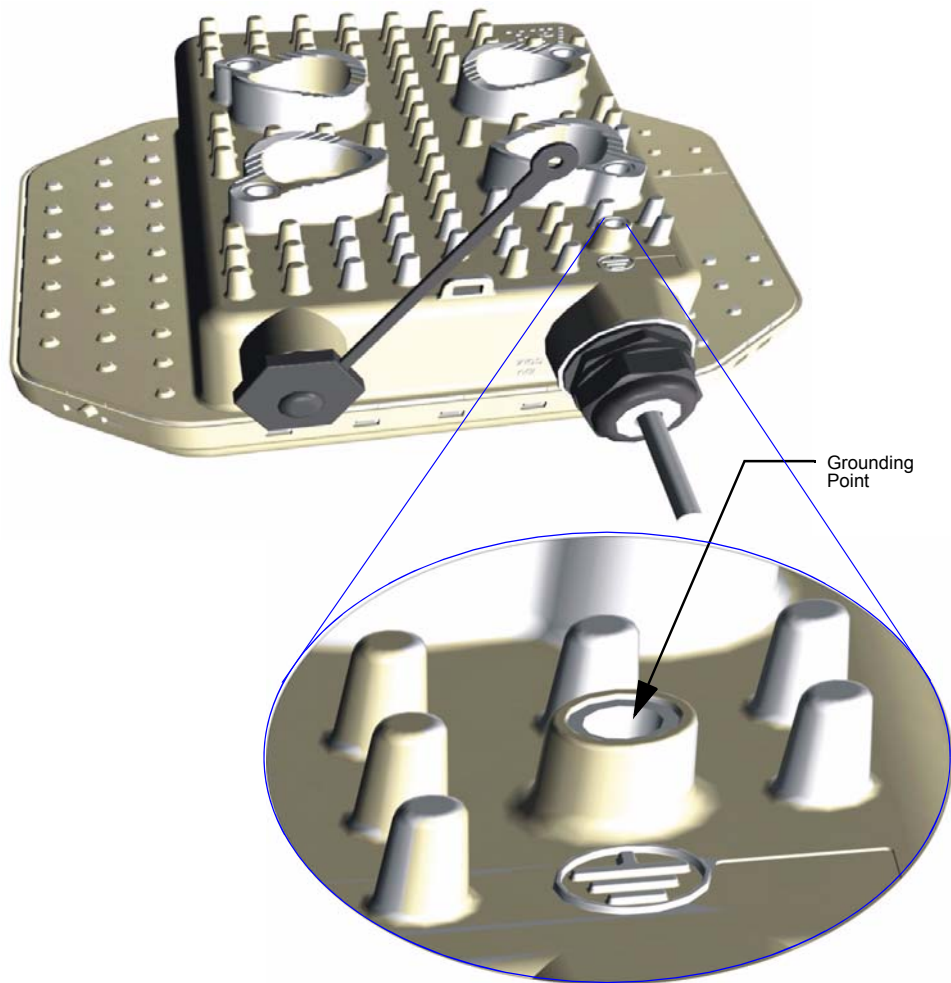

## 2.2.6 Pole-Mounting Bracket Kit

The ODU includes a bracket kit that is used to mount the unit to a pole, radio mast, or part of a tower structure.

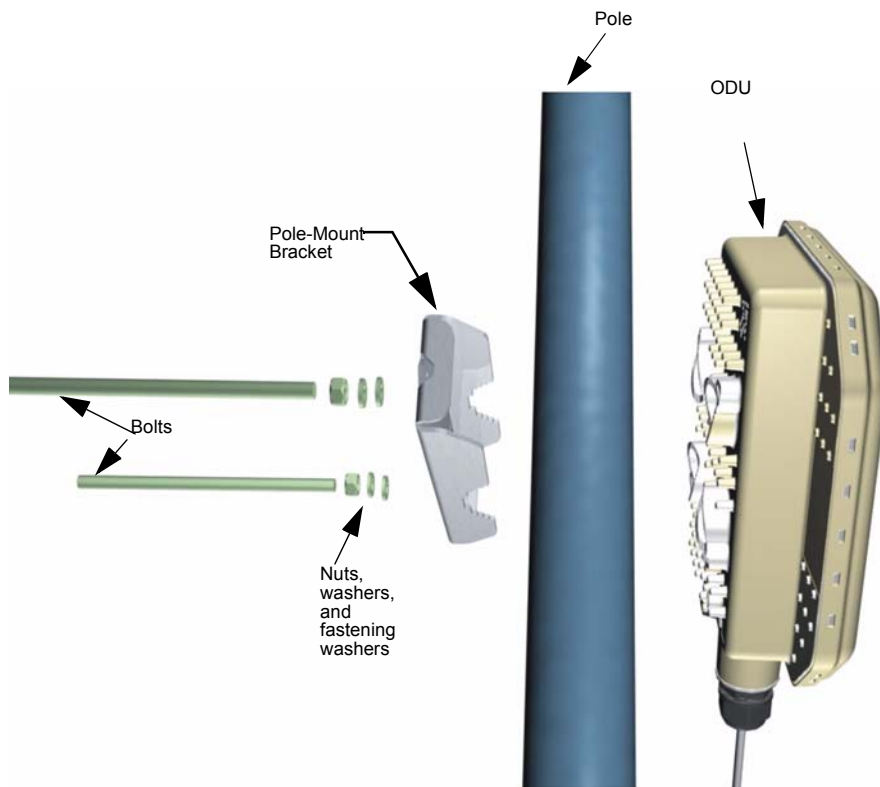

## 2.2.7 Tilt-Mount Bracket (Optional)

The ODU may be mounted to a pole with an optional tilt-mount bracket which provides greater scope and accuracy for adjusting the antenna direction of the ODU to the transmitting Access Unit (base-station).

## 2.2.8 SAU (Optional)

The SAU device can be connected to the ODU during installation to assist with antenna alignment and testing.

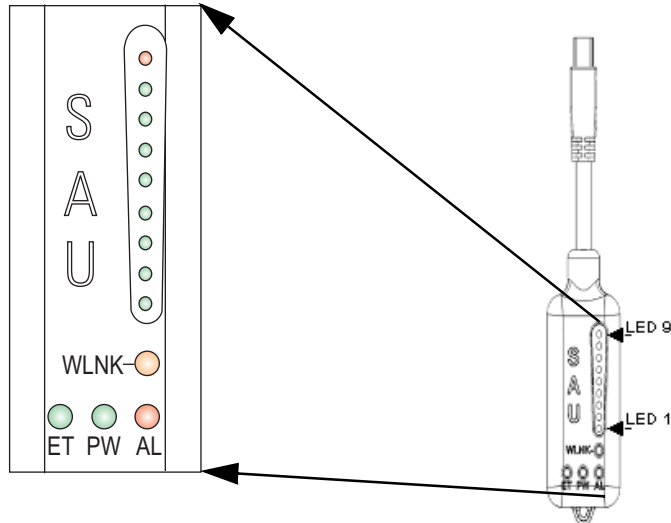

When connected to the ODU, the SAU provides status LED indications as described in the following table:

**Table 2-11: SAU LED Indicators**

| LED           | Status   | Description   |
|---------------|----------|---|
| AL (Alarm)    | Off      | The diagnostic test has passed and the ODU is operating normally.       |
|               | On Red   | An ODU failure has been detected.                                       |
| PW (Power)    | Off      | The ODU is not receiving power or there is an internal 3.3 VDC failure. |
|               | On Green | The SAU is receiving power from the ODU.                                |
| ET (Ethernet) | Off      | There is no valid Ethernet link between the ODU and the IDU.            |
|               | On Green | There is a valid Ethernet link between the ODU and the IDU.             |

Table 2-11: SAU LED Indicators

| LED                             | Status                   | Description  |
|---------------------------------|--------------------------|--|
| WLNK<br>(Wireless link)         | Off                      | The ODU is not connected to a base station.  |
|                                 | On Orange                | The ODU is connected to and receives services from a base station (Network Entry completed). Link quality is indicated by LEDs 1-9, as described below.  |
|                                 | Blinking Orange          | Authentication has failed due to one of the following reasons (indicated by the WiMAX Link LEDs): <ul style="list-style-type: none"> <li>■ If LEDs 7, 8 and 9 are on: Authentication has been rejected by the RADIUS server.</li> <li>■ If LEDs 8 and 9 are on: Authentication has been rejected by the base station (due to a duplicate subscriber unit name in its database).</li> <li>■ If LED 9 is on: Authentication has failed due to a timeout, or there was a re-authentication failure (connection to the RADIUS server was lost or a mismatched shared secret).</li> </ul> |
| 1                               | On Green                 | 5dB $\leq$ SNR < 10dB  |
| 1-2                             | On Green                 | 10dB $\leq$ SNR < 15dB   |
| 1-3                             | On Green                 | 15dB $\leq$ SNR < 20dB   |
| 1-4                             | On Green                 | 20dB $\leq$ SNR < 24dB   |
| 1-5                             | On Green                 | SNR $\geq$ 24dB and RSSI < -75dBm  |
| 1-6                             | On Green                 | SNR $\geq$ 24dB and RSSI $\geq$ -75dBm   |
| 1-7                             | On Green                 | SNR $\geq$ 24dB and RSSI $\geq$ -70dBm   |
| 1-8                             | On Green                 | SNR $\geq$ 24dB and RSSI $\geq$ -60dBm   |
| 1-9                             | 1-8 On Green<br>9 On Red | RSSI $\geq$ -20dBm (saturation)  |
| 1-8 in sequence                 | Cycle On/Off<br>Green    | Indicates a full frequency scan in progress.   |
| 5, 4&6, 3&7, 2&8, 1 in sequence | Cycle On/Off<br>Green    | Selecting a detected base station with the strongest signal, or a short scan.  |

## 2.3 IDU Hardware Description

The Extreme CPE receives power through its network cable connection using power-over-Ethernet technology. A power injector IDU is included in the Extreme CPE package and provides two RJ-45 Ethernet ports, one for connecting to the ODU (Radio), and the other for connecting to a local LAN switch (Ethernet), as well as two RJ-11 phone ports for VoIP communications.

The Radio port is a propriety 10 PIN RJ-45 port that should not be confused with a regular RJ-45 connection. Use only the propriety cable provided in the package contents. To make sure you are using the right cable count the number of pins on the RJ-45 socket, which should number ten.

The Ethernet port uses an MDI (i.e., internal straight-through) pin configuration. You can therefore use straight-through twisted-pair cable to connect this port to most network interconnection devices such as a switch or router that provide MDI-X ports. However, when connecting the Extreme CPE to a workstation or other device that does not have MDI-X ports, you must use a crossover twisted-pair cable.

The following figures show the external components of the IDU:

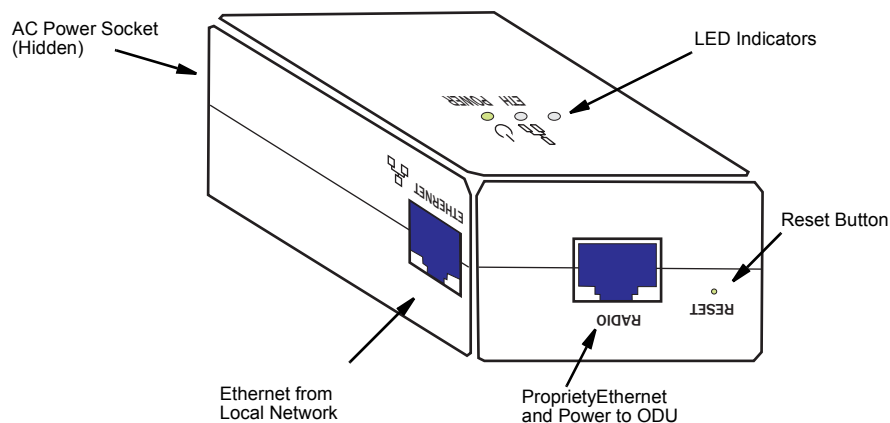

The Extreme CPE does not have a power switch. It is powered on when its Ethernet port is connected to the power injector module, and the power injector module is connected to an AC power source.

The Power LED indicates whether AC power is applied.

The power injector module automatically adjusts to any AC voltage between 100-240 volts at 50 or 60 Hz. No voltage range settings are required.



**WARNING**

The power injector module is designed for indoor use only. Never mount the power injector outside with the Extreme CPE unit.

**CAUTION**

Do not connect a standard RJ-45 Category 5e cable to the ODU port or your unit will not function correctly. Use only the provided propriety 10 PIN Ethernet cable with 10 PIN plug adapters.

**CAUTION**

Due to the DC current the unit draws from its power socket, DO NOT connect a PC to the RJ-45 Data and Power port.

### 2.3.1 10BASE-T/100BASE-TX LAN Port

The IDU provides one 10BASE-T/100BASE-TX RJ-45 data port. This LAN port is standard RJ-45 Ethernet network ports that connect directly to PCs. They can also be connected to an Ethernet switch or hub to support more users.

The port supports automatic MDI/MDI-X operation, so you can use straight-through cables for all network connections to PCs or servers, or to other switches or hubs. Each of these ports support auto-negotiation, so the optimum transmission mode (half or full duplex), and data rate (10 or 100 Mbps) is selected automatically.

### 2.3.2 ODU Port

The IDU includes one propriety 10 pin RJ-45 port that supports a Power-over-Ethernet (PoE) connection to the ODU.

**NOTE**

The Extreme CPE's propriety Ethernet port does not support Power over Ethernet (PoE) based on the IEEE 802.3af standard. Do not try to power the unit by connecting it directly to a network switch that provides IEEE 802.3af PoE. Always connect the unit to the included power injector module.

**CAUTION**

Due to the DC current the unit draws from its power socket, DO NOT connect a PC to the RJ-45 Data and Power port.

### 2.3.3 System Status LEDs

Both the propriety RJ-45 and RJ-45 data ports may be monitored through the LED indicators on the top of the IDU. The LED indicators are described in the following table.

**Table 2-12: System Status LED Indicators**

| LED   | Status         | Description   |
|-------|----------------|---|
| ETH   | On Green       | Ethernet port has a valid link with an attached device. |
|       | Flashing Green | The port is transmitting or receiving data.             |
|       | Off            | Ethernet port has no link with another device.          |
| POWER | On Green       | Power is being supplied to the ODU.                     |
|       | Off            | The power supply is disconnected.                       |

### 2.3.4 Power Adapter Socket

The power socket is located on the rear panel of the IDU. The power socket is for the AC power adapter connection.

The unit is powered on when connected to its AC power adapter, and the power adapter is connected to an AC power source between 100-240 volts at 50-60Hz.

#### CAUTION



Use **ONLY** the power adapter IDU supplied with the Extreme CPE. Otherwise, the product may be damaged.

### 2.3.5 Backup Battery Charger (Optional)

An optional backup battery charger can be used with the AC power adapter to provide redundant power in the event that the AC supply fails.

The backup battery charger holds 10 rechargeable AA-type batteries. The batteries are charged while the AC power adapter is powering the Extreme CPE units. If the AC power fails, the batteries can power the Extreme CPE for up to five hours.

## 2.4 Installation Steps



### CAUTION

Only the Extreme CPE ODU can be installed outdoors.

The BreezeMAX Extreme IDU power supply is an indoor unit and must not be installed outdoors.

ONLY experienced installation professionals who are familiar with local building and safety codes and, wherever applicable, are licensed by the appropriate government regulatory authorities should install outdoor antennas.

Failure to abide may void the BreezeMAX Extreme CPE product warranty and may expose the end user or Service Provider to legal and financial liabilities. Alvarion and its resellers or distributors are not liable for injury, damage or regulation violations associated with the installation of Outdoor antennas.

Before installing the BreezeMAX K2 CPE, verify that you have all the items listed in the package checklist above. If any of the items are missing or damaged, contact your local dealer. Also, be sure you have all the necessary tools and cabling before installing the Extreme CPE.



### Hardware installation of the Extreme CPE involves these steps:

- Mount the ODU on a pole, mast, or tower using the mounting bracket.
- Install the IDU indoors.
- Connect the ODU-IDU Ethernet cable and a grounding wire to the ODU.
- Align the ODU antenna with the base station.

## 2.5 ODU Installation

The ODU includes its own bracket kit for mounting the unit to a 1 to 4 inch diameter steel pole or tube. The pole-mounting bracket allows the unit to be mounted to part of a radio mast or tower structure.



### CAUTION

The planning and installation of the ODU requires professional personnel that are trained in the installation of radio transmitting equipment. The user is responsible for compliance with local regulations concerning items such as building safety codes, use of lightning arrestors, and grounding. Therefore, you must consult a professional contractor knowledgeable in local radio regulations prior to equipment installation.

### 2.5.1 ODU Location

The ODU should be installed outdoors, mounted to a pole using the included mounting bracket.



**When selecting an suitable location for the unit, consider these points:**

- The ODU should be installed where it can provide a direct, or near line of sight with the WiMAX base station. Normally, the higher the unit placement, the better the link quality.
- Make sure there are no other radio antennas within 2 m (6 ft) of the ODU.
- Place the ODU away from power and telephone lines.
- Avoid placing the ODU too close to any metallic, reflective surfaces, such as roof-installed air-conditioning equipment, wire fences, or water pipes.

### 2.5.2 Mount the Unit

The ODU's pole-mounting bracket attaches directly to the ODU using two long threaded bolts. The bracket has V-shaped edges on one side that clamp the unit to a pole. The bracket allows the ODU's built-in antenna to be mounted to a pole in either a vertical or horizontal polarization direction.



**Perform the following steps to mount the unit to a 1 to 4 inch diameter steel pole or tube using the mounting bracket:**

- 1 Attach the two threaded bolts to the back of the ODU using a flat screwdriver. Make sure you use the correct threaded holes for the required polarization.

#### NOTE



Antennas in a wireless link must be mounted in the same polarization direction.

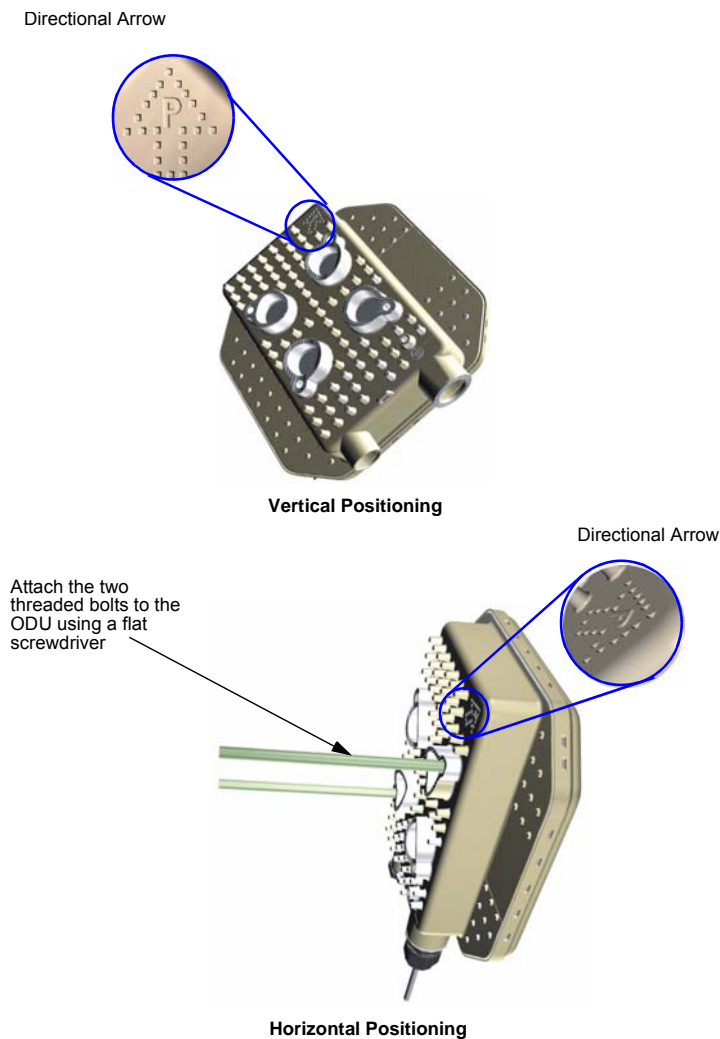

- 2 Place the ODU against one side of the pole and then fit the bracket onto the threaded bolts. The bracket's V-shaped edges should be against the pole.

#### NOTE



Make sure that the ODU connectors always face downward.

- 3 Use the included nuts and washers to secure the ODU to the pole. The securing nuts should be just tight enough to hold the ODU to the pole. (The bracket may need to be rotated around the pole during the antenna alignment process.)

Use the provided nuts and washers to attach the bracket to the bolts

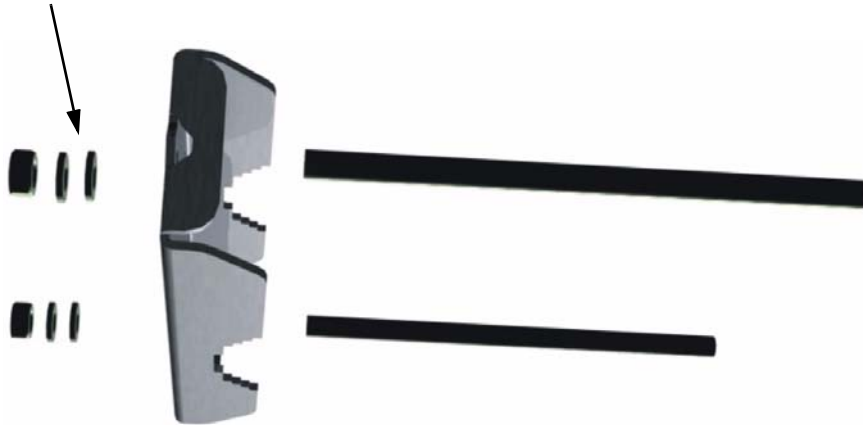

Tighten the nuts to secure the ODU to the pole

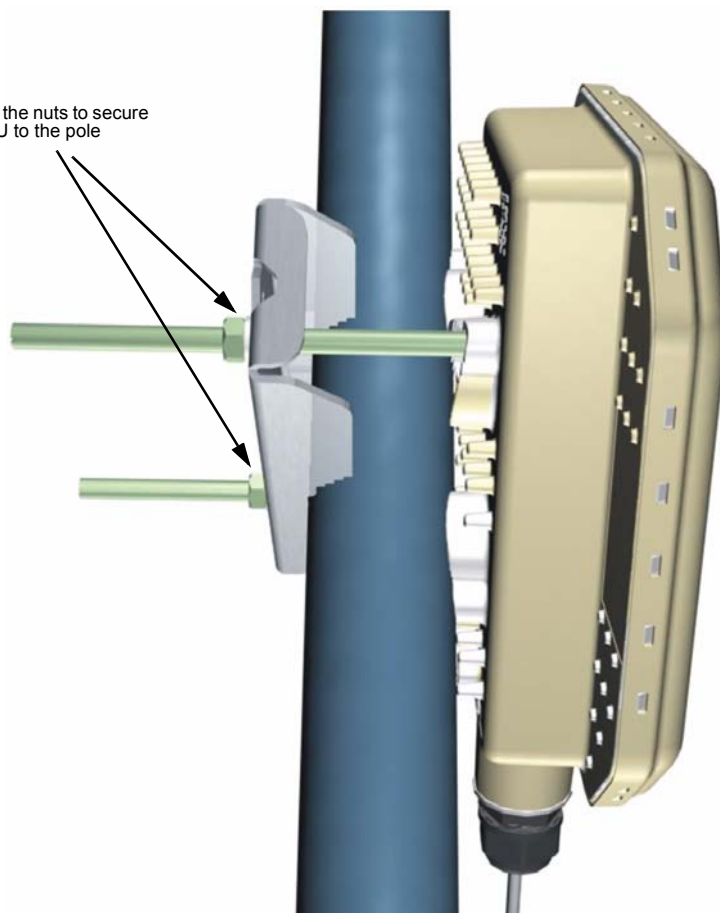



## 2.6 IDU Installation

### 2.6.1 Select a location

The IDU can be installed indoors on any horizontal surface, such as a desktop or shelf. Be sure to select an suitable location for the device. Consider these points:

- Select a cool, dry place, which is out of direct sunlight.
- The device should have adequate space (approximately two inches) on all sides for proper air flow.
- The device must be near an AC power outlet that provides 100 to 240 V, 50 to 60 Hz.
- Be sure to attach the IDU ground wire to a nearby electrical earth point.
- The device should be accessible for network cabling and allow the status LED indicators to be clearly visible.

### 2.6.2 Installing the unit

The IDU is a plug-and-play device, so once it has been connected to your PC and powered up, it is fully operable.



**To connect the Extreme CPE, follow these steps:**

- 1 Power on the IDU by connecting the AC power adapter and plugging it into an AC power source.



#### CAUTION

Use ONLY the IDU power adapter supplied with the Extreme CPE. Otherwise, the CPE may be damaged.



#### CAUTION

Do not install the power injector outdoors. The unit is for indoor installation only.



**CAUTION**

Install lightning protection at the power injector end of the Ethernet cable, use a lightning arrestor immediately before the cable enters the building.

**NOTE**

The Extreme CPE's Ethernet port does not support Power over Ethernet (PoE) based on the IEEE 802.3af standard. Do not try to power the unit by connecting it directly to a network switch that provides IEEE 802.3af PoE. Always connect the unit to the included IDU power injector module.

- 2 Observe the Indicator LEDs. When you power on the IDU, verify that the Power LED turns on and that the other LED indicators start functioning.
- 3 Connect Category 5 or better Ethernet cables from the IDU's LAN ports to the network ports of your PCs. Alternatively, you can connect the LAN ports to an Ethernet switch or other devices. Make sure the length of each cable does not exceed 100 meters (328 ft).

If your PCs are powered on, the RJ-45 LAN port LEDs on the IDU should turn on to indicate valid links.

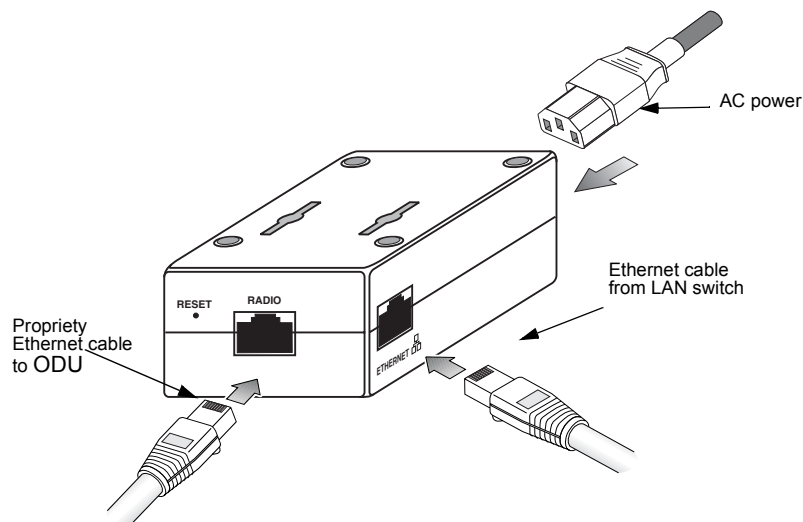

- 4 Use your PC's web browser to access the unit's management interface to make any configuration changes. For more information, see Chapter 3, "Initial Configuration."

**NOTE**

The Extreme CPE will search for a base station upon boot up, however if no base station is found the hardware will automatically reboot every ten minutes.

## 2.7 ODU Cable Connection

The ODU needs to be connected to the IDU using propriety Ethernet cable, and the ODU must be grounded by connecting a grounding wire.

### 2.7.1 ODU-IDU Propriety Ethernet Cable Connection

Use outdoor-rated 10 pin propriety Ethernet cable with RJ-45 connectors on each end. Before connecting the cable, first plan a cable route from the ODU outdoors to the IDU indoors. Consider these points:

- Make sure the cable length does not exceed 90 meters (295 ft).
- Determine a building entry point for the cable.
- Determine if conduits, bracing, or other structures are required for safety or protection of the cable.
- Be sure to ground the outdoor-rated 10 pin propriety Ethernet cable immediately before it enters the building.
- For additional lightning protection, it is recommended to use a lightning arrester immediately before the Ethernet cable enters the building.



**To connect the ODU-IDU Ethernet cable, follow these steps:**

- 1 Remove the rubber sealing cover from the IDU COM port on the ODU.
- 2 Cut the Ethernet cable to the required length and feed it through the port cover. Then use a crimp tool to attach an RJ-45 connector to the Ethernet cable.

Make sure the Ethernet twisted-pair wires are attached to the RJ-45 connector following standard pin assignments.

- 3 Connect the Ethernet cable to the IDU COM RJ-45 connector.
- 4 Screw the port cover back into the unit and tighten it to ensure protection against moisture.

- 5 Seal the IDU COM connector using tar seal or weatherproof tape to protect against rain and moisture.
- 6 Route the Ethernet cable from the ODU to the IDU following your cable plan and connect it to the ODU port on the IDU. The RJ-45 port LED on the IDU should turn on to indicate a valid link.

**NOTE**

Connecting the propriety Ethernet cable to the IDU powers on the ODU.

The sequence of inserting the RJ-45 cable into the ODU and the supplied ODU components are described in the following diagram.



- 7 Insert the sealing cover into the port to ensure protection against moisture.

- 8 Seal the IDU COM connector using tar seal or weatherproof tape to protect against rain and moisture.



## 2.7.2 ODU 10 PIN Ethernet Port

The PoE ports on both the ODU and IDU use a non-standard propriety 10 PIN connection. You must use the cable provided with the unit. Attempting to insert a standard RJ-45 plug into either port simply won't fit and may damage the unit.

The following figure illustrates how the pins on the RJ-45 connector are numbered. Be sure to hold the connectors in the same orientation when attaching the wires to the pins.

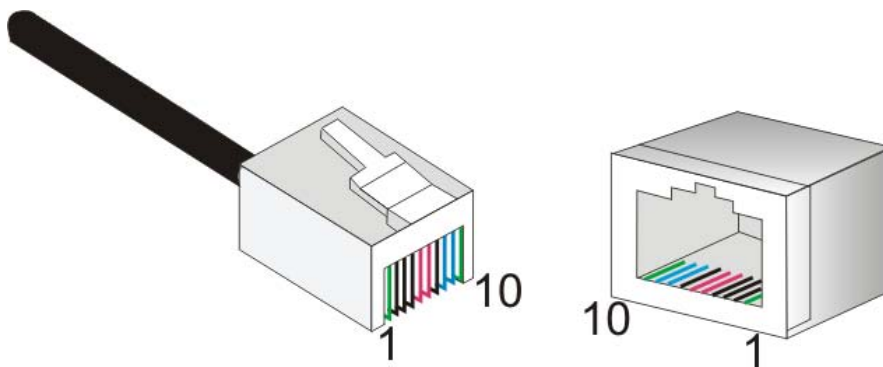

## 2.7.3 Propriety 10 Pin Assignments

The Extreme CPE cable provides pin-to-pin connection on both ends.

The following figure shows the required wire pair connections.

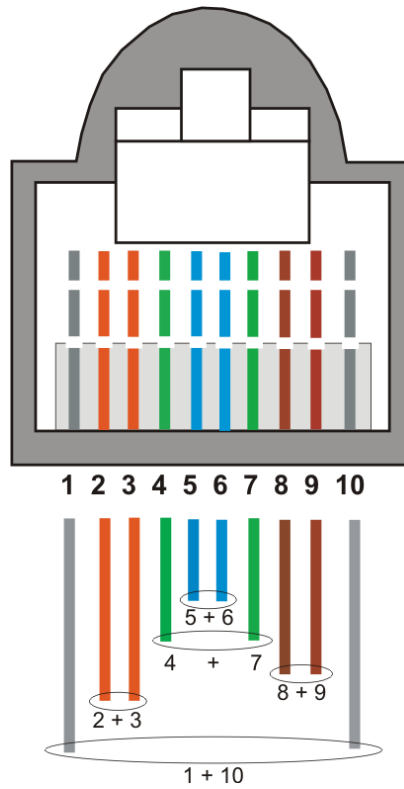

**Table 2-13: Propriety Cable Color Codes**

| Wire color     | Pin |
|----------------|-----|
| Striped Grey   | 1   |
| Orange         | 2   |
| Striped Orange | 3   |
| Green          | 6   |
| Striped Blue   | 4   |
| Blue           | 5   |
| Striped Green  | 7   |
| Brown          | 8   |
| Striped Brown  | 9   |
| Grey           | 10  |

**Table 2-14: Propriety MDI and MDI-X Port Pinouts**

| PIN   | MDI-X Signal Name         | MDI Signal Name           |
|---|---------------------------|---------------------------|
| 1   | FXS Channel B TIP Line    |                           |
| 2   | Receive Data plus (RD+)   | Transmit Data plus (TD+)  |
| 3   | Receive Data minus (RD-)  | Transmit Data minus (TD-) |
| 4   | Transmit Data plus (TD+)  | Receive Data plus (RD+)   |
| 5   | Power over Ethernet (V+)  |                           |
| 6   | Power over Ethernet (V-)  |                           |
| 7   | Transmit Data minus (TD-) | Receive Data minus (RD-)  |
| 8   | FXS Channel A TIP Line    |                           |
| 9   | FXS Channel A RING Line   |                           |
| 10  | FXS Channel B RING Line   |                           |
| <b>Note:</b> The "+" and "-" signs represent the polarity of the wires that make up each wire pair. |                           |                           |

To comply with safety regulations, the shield of the ODU-IDU outdoor-rated Ethernet cable must be connected to protective ground (earth). The grounding point can be either inside the building, or immediately at the entry point to the building, depending on where a protective ground is available.

**CAUTION**

Grounding the ODU-IDU Ethernet cable must be performed by a professional installer in conformance with local safety regulations.

This document proposes one method for grounding the outdoor-rated Category 5E Ethernet cable through its drain wire. The actual connection method employed is left to the professional installer.



To ground the ODU-IDU Ethernet cable, follow these steps:

- 1 Strip back about a one inch (2.4 cm) section of the Ethernet cable jacket to expose the drain wire.

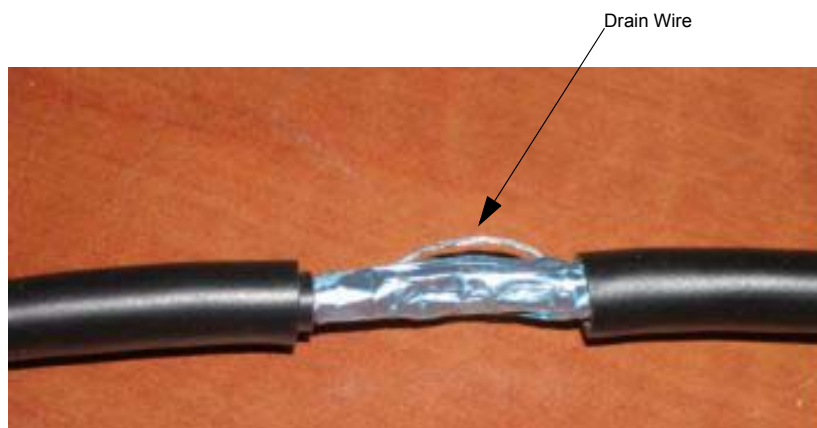

- 2 Attach a grounding cable to the drain wire and then connect it to protective earth.
- 3 Use weatherproof tape to cover and seal the attachment area on the Ethernet cable.

### 2.7.3.1 Ground Wire Connection

When connecting a ground wire to the ODU, use the grounding screw located on the base of the unit. Be sure to use #14 AWG or larger copper core ground wire.

**CAUTION**

Be sure that grounding is available and that it meets local and national electrical codes. Grounding the ODU must be performed by a professional installer.



To connect a grounding wire to the ODU, follow these steps:

- 1 Crimp a ring lug onto the end of the ground wire before connecting it to the unit.
- 2 Place the ground wire lug on the grounding point and firmly tighten the screw.

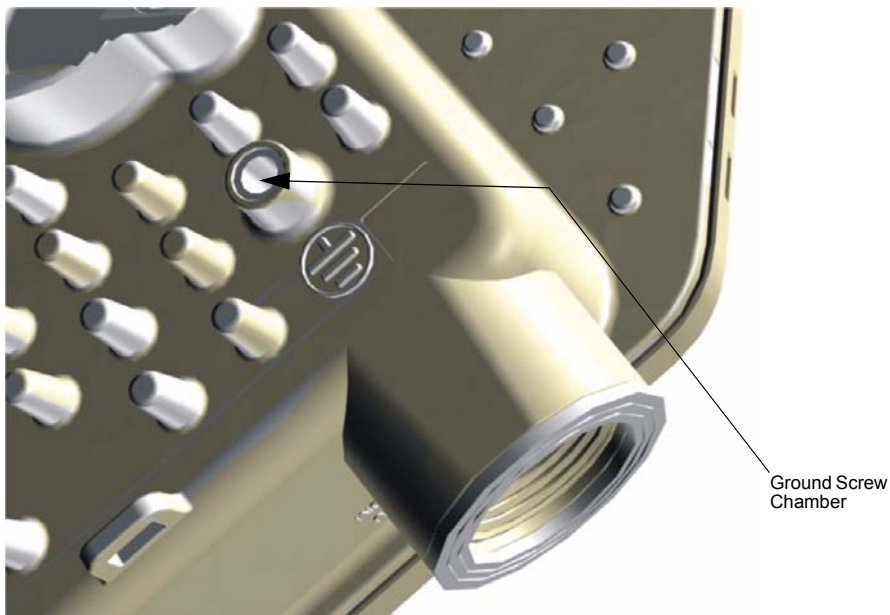

- 3 Connect the other end of the grounding wire to a good ground (earth) connection.

**NOTE**



Use cable strips to secure all cables to the pole.



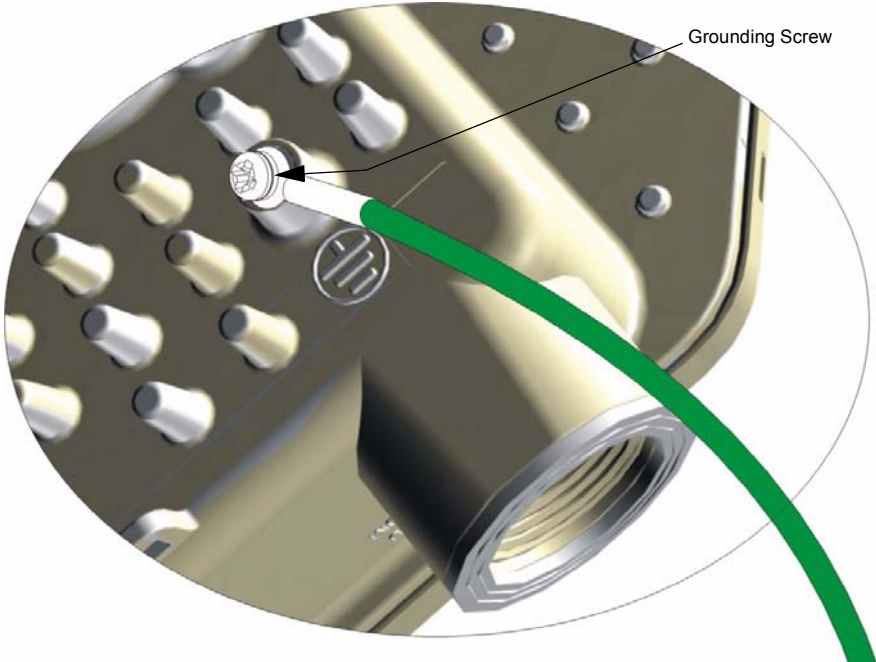

## 2.8 IDU Data Port

For standard category 5e or better, non-proprietary Ethernet cables follow the guidelines below.

### 2.8.0.1 Preparing Ethernet Cables

Use a crimp tool for RJ-45 connectors to prepare the wires. Insert them into the appropriate pins and use the tool to crimp the connector. Make sure to do the following:

- Remove as small a length as possible of the external jacket. Verify that the external jacket is well inside the sealing cover when connected to the unit, to ensure good sealing.
- Pull back the shield drain wire before inserting the cable into the RJ-45 connector, to ensure a good connection with the connector's shield after crimping.
- For 10/100BASE-TX connections, a twisted-pair cable must have two pairs of wires. Each wire pair is identified by two different colors. For example, one wire might be green and the other, green with white stripes. Also, an RJ-45 connector must be attached to both ends of the cable.

#### CAUTION



Each wire pair must be attached to the RJ-45 connectors in a specific orientation. DO NOT plug a phone jack connector into the RJ-45 port. Use only twisted-pair cables with RJ-45 connectors that conform with FCC standards.

The following figure illustrates how the pins on the RJ-45 connector are numbered. Be sure to hold the connectors in the same orientation when attaching the wires to the pins.

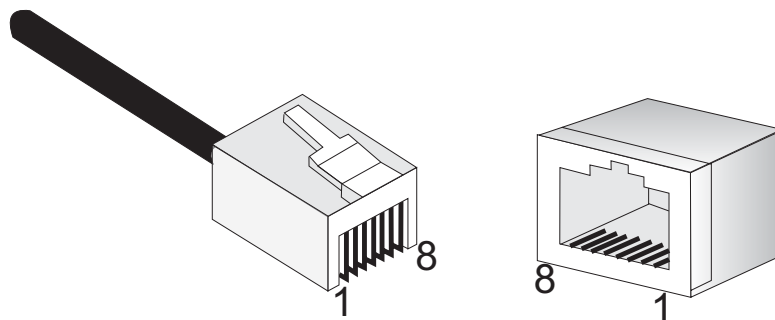

## 2.8.1 10/100BASE-TX Pin Assignments

The Extreme CPE cable provides pin-to-pin connection on both ends.

The following figure shows the required wire pair connections.

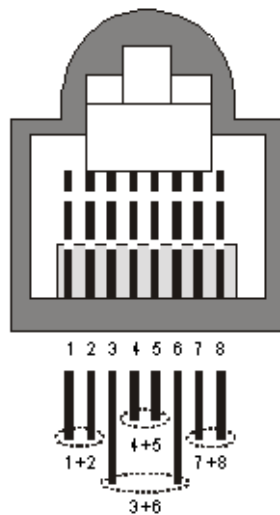

The color codes used in standard cables supplied by Alvarion are as listed in the following table:

**Table 2-15: Cable Color Codes**

| Wire color   | Pin |
|--------------|-----|
| Blue         | 1   |
| Blue/white   | 2   |
| Orange       | 3   |
| Orange/white | 6   |
| Brown        | 4   |
| Brown/white  | 5   |
| Green        | 7   |
| Green/white  | 8   |

**Table 2-16: 10/100BASE-TX MDI and MDI-X Port Pinouts**

| PIN   | MDI-X Signal Name         | MDI Signal Name           |
|---|---------------------------|---------------------------|
| 1   | Receive Data plus (RD+)   | Transmit Data plus (TD+)  |
| 2   | Receive Data minus (RD-)  | Transmit Data minus (TD-) |
| 3   | Transmit Data plus (TD+)  | Receive Data plus (RD+)   |
| 6   | Transmit Data minus (TD-) | Receive Data minus (RD-)  |
| 4,5,7,8   | Not used                  | Not used                  |
| <b>Note:</b> The "+" and "-" signs represent the polarity of the wires that make up each wire pair. |                           |                           |

## 2.8.2 Extreme CPE Cables



**NOTE**

The length of the Ethernet cable connecting the Extreme CPE to the data equipment, should not exceed 100 meters.

Use only Category 5E Ethernet cables from either Alvarion or any of the approved manufacturers, listed in [Table 2-17](#). Consult with Alvarion's specialists on the suitability of other cables.

**Table 2-17: Approved Category 5E Ethernet Cables**

| Manufacturer   | Part Number |
|--|-------------|
| Superior Cables Ltd.<br><a href="http://www.superior-cables.com">www.superior-cables.com</a> | 612098      |

Table 2-17: Approved Category 5E Ethernet Cables

| Manufacturer  | Part Number |
|---|-------------|
| HES Cabling Systems<br><a href="http://www.hescs.com">www.hescs.com</a>   | H5E-00481   |
| Teldor<br><a href="http://www.teldor.com">www.teldor.com</a>  | 8393204101  |
| Southbay Holdings Limited<br>11th Fl., 15, Lane 347, Jong Jeng Rd.<br>Shin Juang City, Taipei County<br>Taiwan, R.O.C.<br>Attn: Eva Lin<br>Tel. 886-2-2832 3339<br>Fax. 886-2-2206 0081<br>E-mail: <a href="mailto:eva@south-bay.com.tw">eva@south-bay.com.tw</a> | TSM2404A0D  |
| GU-Tech., LLC . - A Member of OVIS Group<br>Tel/Fax : 732 918 8221 Mobile: 718 909 4093<br><a href="http://www.OVIS.COM.TW">www.OVIS.COM.TW</a> <a href="http://www.GU-TECH.COM">www.GU-TECH.COM</a>  |             |

In case of missing information in the manufacturer's WEB site (product specifications, ordering issues, etc.), it is highly recommended to contact the manufacturer's sales representative directly.

## 2.9 ODU Antenna Alignment

The ODU will provide the best link quality when its antenna is aligned in the direction of the WiMAX base station. The optional SAU can be connected to the ODU to provide status LED indications and assist with antenna alignment.



**To align the ODU antenna using the SAU, follow these steps:**

- 1 Remove the rubber sealing cover from the SAU port on the ODU.
- 2 Connect the SAU device to the SAU port. The PW (power) LED should turn on to indicate that it is properly connected.
- 3 Point the ODU antenna in the general direction of the base station, then pan the ODU back and forth while watching the link quality LEDs (see [“SAU LED Indicators” on page 18](#)).

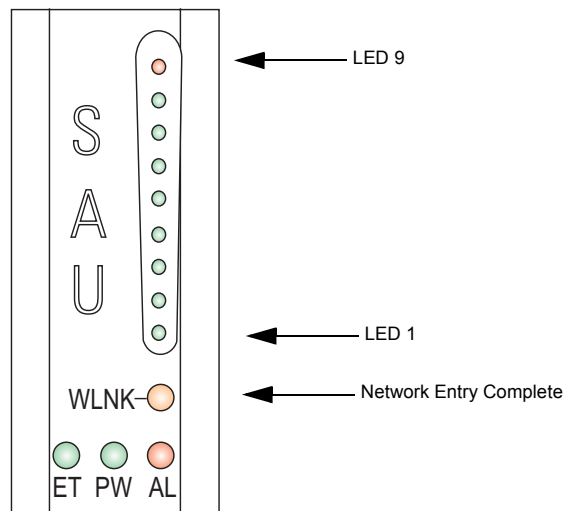

- 4 Find the point where the link quality is best and secure the ODU in that position. Verify that the SAU's WLNK LED is on, indicating that the unit is synchronized with the base station.

### NOTE

If all the SAU link quality LEDs are on, including LED 9 (red), the received signal strength is too high. Move the ODU's position so that only LEDs 1 to 8 are on.



- 5 Remove the SAU connection and replace the rubber sealing cover on the port.

- 6 Seal the SAU connector using tar seal or weatherproof tape to protect against rain and moisture.



### 2.9.1 Align the WiMAX Antenna

After the Extreme CPE unit has been mounted, connected, and its radio is operating, the antenna must be accurately aligned to ensure optimum performance on the wireless link. This alignment process is particularly important for long-range links.

To start the alignment process, you can just point the antenna in the general direction of the Access Unit's (base station) antenna using binoculars or a compass. For accurate alignment, you must monitor the signal strength LEDs as the antenna moves horizontally.

The signal strength LEDs indicate the received radio signal strength for the link. The more LEDs that turn on, the stronger the signal.

When you move the antenna during alignment, the radio signal from the remote antenna can be seen to have a strong central main lobe and smaller side lobes. The object of the alignment process is to set the antenna so that it is receiving the strongest signal from the central main lobe.

To align the antennas in the link, monitor the signal strength LEDs. For details see [Table 2-11](#). Perform the following procedure:

- 1 Pan the ODU horizontally back and forth while checking the LEDs, preferably with an SAU.

- 2 Find the point where the signal is strongest (refer to [Table 2-11](#)) and leave in that position.



**NOTE**

Sometimes there may not be a central lobe peak because vertical alignment is too far off; only two similar peaks for the side lobes are detected.



---

## Chapter 3 - Initial Configuration

### In This Chapter:

- [“Introduction” on page 44](#)
- [“Accessing the Web Management Interface” on page 44](#)

## 3.1 Introduction

The Extreme CPE offers a user-friendly web-based management interface for the configuration of all the unit's features. Any PC directly attached to the unit can access the management interface using a web browser, such as Internet Explorer (version 6.0 or above).

The initial configuration steps can be made through the web-browser interface using the default IP address.

### 3.1.1 Accessing the Web Management Interface

The Extreme CPE has the default IP address of 192.168.254.251 and the subnet mask 255.255.255.0. Be sure to first check if your PC's IP address is set on the same subnet as the Extreme CPE and that the PC's IP address is 192.168.254.250.

#### NOTE



The Extreme CPE does not support DHCP. Your PC must be set to the same subnet as the unit, ie. 192.168.254.x, and be set to the specific IP address 192.168.254.250.

In the web browser's address bar, type the default IP address:  
`http://192.168.254.251.`

The web browser displays the Extreme CPE's login page.

#### NOTE



The Extreme CPE will scan for a base station upon boot up, however if no base station is found the unit will automatically reboot every ten minutes causing a temporary loss of connection to the web interface. To overcome this problem reload the web page.

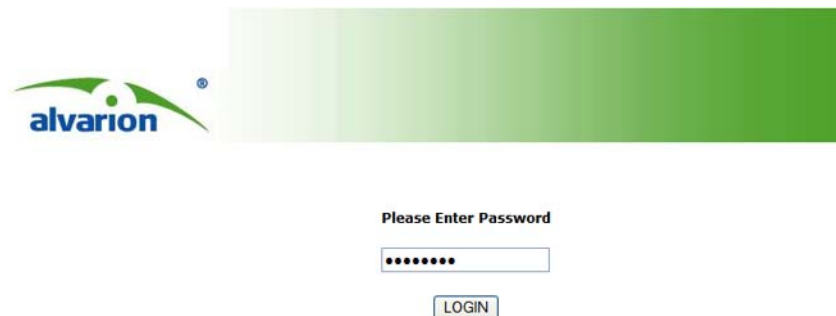

**Figure 3-1: Login Window**

To log in, enter the user password **installer**, and click Login. The homepage displays.

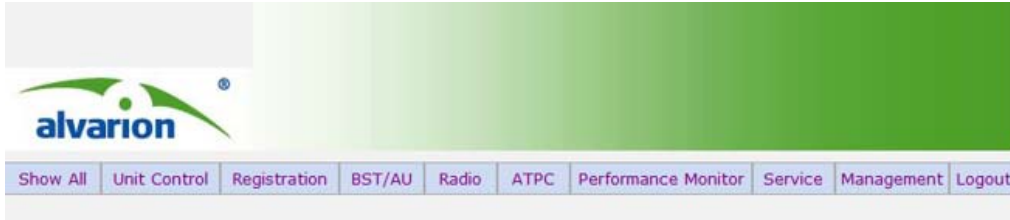

Welcom to Alvarion K2 Configuration page.  
Please use menu bar to configure or get  
infomation from device.

**Figure 3-2: Main Window****NOTE**

It is strongly recommended that you configure your own password. If a password is not configured, the management interface is not protected and anyone who can connects to the Extreme CPE may be able to compromise your network security.



---

## Chapter 4 - System Settings

### In This Chapter:

- “Introduction” on page 48
- “System Status” on page 49

## 4.1 Introduction

The Extreme CPE's System menu allows you to perform general management functions for the unit, including setting the system time, configuring an access password, and upgrading the system software.

Through an easy to use web management interface the Extreme CPE can be configured to be a powerful wireless connection to any telecommunications network.



### NOTE

You can use the web browser interface to access IP addressing only if the Extreme CPE already has an IP address that is reachable through your network.

The default IP address of the Extreme CPE is 192.168.254.251. You should set your PC network card to be on the same subnet, with a network mask of 255.255.255.0 and an IP address of 192.168.254.250. This can be set through the Network Connections menu on your PC.

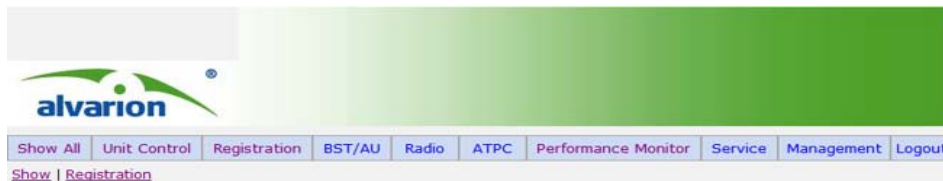

**Figure 4-3: Show Settings Menu**

## 4.2 System Status

The Show All page is a display-only menu of non-configurable parameters for Unit Control, Registration, Base Station Identification (BSID), Radio, Multi rate, Adaptive Transmission Power Control (ATPC) and Service. To configure the parameters associated with each show menu item refer to the sections listed in the main menu.

| Show All parameters, Unit Control       |                                     |
|---|-------------------------------------|
| SU Type                                 | CPE Pro SQ                          |
| CPE Family                              | Sequans                             |
| Serial Number                           | RF_SN                               |
| MAC Address                             | 00:12:0A:66:66:66                   |
| MAC Address Control Number              | 14                                  |
| Radio Band                              | 5.XGHz                              |
| Hardware Version                        | ROA                                 |
| Hardware Configuration                  | ODU201                              |
| RF Version                              | PMC1.7                              |
| SU Interface Type                       | 1D                                  |
| Radio Type                              | 1 Rx , 1 Tx                         |
| Antenna Type                            | V Antenna                           |
| Ethernet Port Auto Negotiation          | Enable                              |
| Ethernet Port Speed & Duplex            | 100 Mbps Full duplex                |
| Operation Mode                          | IPCS                                |
| Unit Status                             | Searching for Base Station          |
| SW Boot Version                         | 0.0.2.0                             |
| Main SW File Name                       | X_AWB_0_0_2_0.app                   |
| Main SW Version                         | 0.0.2.0                             |
| Shadow SW File Name                     | X_AWB_0_0_2_0.app                   |
| Shadow SW Version                       | 0.0.2.0                             |
| Running From                            | Main                                |
| TFTP Server IP address(for SW download) | 192.168.254.250                     |
| SW File Name                            | K2_OD210_Firmware.bz                |
| Configuration File Upload Name          | SU_UPLOAD_CFG                       |
| Configuration File Download Name        | SU_DOWNLOAD_CFG                     |
| List of TM&PM Files gathered            | 00120A666666_01_01_1970_01_16_18_05 |

**Figure 4-4: Show All - Unit Control**

**UNIT CONTROL** – The Show All - Unit Control menu provides information on the default system configuration and radio type.

- **SU Type** – Describes the service unit (SU) type.
- **CPE Family** – Describes the primary chipset of the Extreme CPE.
- **Serial Number** – Describes the serial number of the Extreme CPE unit. This number can be used to determine the identity of the subscriber unit by the base station operator.
- **MAC Address** – Describes the physical layer address of the LAN port. The WAN port MAC address can be determined by adding “1” to the LAN port MAC address.
- **MAC Address Control Number** – Displays the MAC address control number.
- **Radio Band** – Describes the radio band in use. The radio band for the Extreme CPE is 5.x.
- **Hardware version** – Describes the revision of hardware in use.
- **Hardware configuration** – Describes the identity of the current hardware configuration by serial number.
- **RF version** – Describes the radio frequency (RF) or rate of oscillation of the electrical circuit.
- **SU Interface Type** – Describes the number of ports available on the interface. “D” refers to data ports, “V” refers to VoIP ports, with a prefix number in use as a quantifier.
- **Radio Type** – Describes the receive (Rx) and transmit (Tx) capacity of the radio.
- **Antenna Type** – Describes the antenna type employed by the Extreme CPE.
- **Ethernet Port Auto Negotiation** – Describes the Ethernet port auto negotiation enable/disable state.
- **Ethernet Port Speed & Duplex** – Describes the speed and duplex capabilities to which the Ethernet port has been set to.



- **Operation Mode** – Describes the operation mode of the Extreme CPE, either IPCS or ETHCS where IPCS refers to transparent delivery of IPv4 packets and ETHCS refers to transparent delivery of tagged 802.3 packets over Ethernet.
  
- **Unit Status** – Describes the connectivity status of the Extreme CPE to the base station.
  
- **SW Boot Version** – Describes the current software boot version file.
  
- **Main SW File Name** – Describes the name of the current firmware.
  
- **Main SW Version** – Describes the version of the current firmware.
  
- **Shadow SW File Name** – Describes the name of the secondary, or shadow, firmware file.
  
- **Shadow SW Version** – Describes the version of the shadow firmware file.
  
- **Running From** – Describes the firmware file being used by the Extreme CPE as a running configuration. (Options: Main, or Shadow)
  
- **TFTP Server IP address(for SW download)** – Describes the TFTP server IP address that is being used for firmware download.
  
- **SW File Name** – Describes the name of the download firmware file from the TFTP server.
  
- **Configuration File Upload Name** – Describes the name of the uploaded configuration file.
  
- **Configuration File Download Name** – Describes the name of the current configuration file.
  
- **List of TM&PM Files Gathered** – Describes the TM (Traffic Monitoring) and PM (Performance Monitoring) files that the unit has detected.

| License type  |               |           |               |               |               |                |                   |
|---------------|---------------|-----------|---------------|---------------|---------------|----------------|-------------------|
| POTS 1        | POTS 2        | MIR=2Mbps | MIR=6Mbps     | Unlimited MIR | Ethernet CS   | VPN over IP CS | Switching Antenna |
| Not Available | Not Available | Available | Not Available | Not Available | Not Available | Not Available  | Not Available     |

**Figure 4-5: Show All - License Type**

**LICENSE TYPE** – Describes the availability of VoIP ports, operator preset maximum information rates (MIR), Ethernet status, virtual private networks (VPN) status and switching antenna status.

- **POTS1/2** – Describes the availability status of the VoIP plain old telephone service (POTS) ports. ‘Available’ indicates that the specified VoIP port is open for use.
- **MIR=2Mbps** – Describes the operator preset maximum information rate (MIR) state per subscriber at 2Mbps upload/download.
- **MIR=6Mbps** – Describes the operator preset maximum information rate (MIR) state per subscriber at 6Mbps upload/download.
- **Unlimited MIR** – Describes if the operator preset maximum information rate (MIR) is unlimited in upload/download bandwidth, or unavailable to the subscriber.
- **Ethernet CS** – Describes the Ethernet convergence sublayer (CS) status.
- **VPN over IP CS** – Describes the status of the virtual private network (VPN) over internet protocol (IP) convergence sublayer.
- **Switching Antenna** – Describes the status of the switching antenna.

| Show All parameters, Best BS ID |                   |
|---------------------------------|-------------------|
| Configured Best BS ID           | 00.00.00.00.00.00 |
| Current Best BS ID              | 00.00.00.00.00.00 |
| Current Best BS RSSI(dBm)       | 0                 |
| Current Best BS SNR(dB)         | 0                 |
| Current Bandwidth               | 0                 |

**Figure 4-6: Show All - Best BSID**

**BEST BSID** – The Show All - Best BSID page displays information on the base station identity (BSID), as well as signal strength indication, noise ratio and bandwidth of the WiMAX connection.

- **Configured Best BS ID** – Describes the configured base station identity, in the form xx.xx.xx.xx.xx.xx.
- **Current Best BS ID** – Describes the identity of the best base station, in the form xx.xx.xx.xx.xx.xx.
- **Current Best BS RSSI (dBm)** – Describes the receive signal strength indicator of the WiMAX link, in decibels per milliwatt.
- **Current Best BS SNR (dB)** – Describes the signal to noise ratio of the WiMAX link, in decibels.
- **Current Bandwidth** – Describes the bandwidth of the WiMAX link.

Show All parameters, Radio parameters

|                                     |       |
|-------------------------------------|-------|
| Configured Bandwidth                | 10Mhz |
| Configured TX Antenna Selection     | 0     |
| Configured RX Antenna Selection     | 0     |
| Configured Rx Attenuator parameters | 0     |
| Current Bandwidth                   | 0     |
| Current TX Antenna Selection        | 0     |
| Current RX Antenna Selection        | 0     |
| Current Rx Attenuator parameters    | 0     |

Figure 4-7: Show All - Radio Parameters

**RADIO PARAMETERS** – The Show All - Radio Parameters page displays information on the bandwidth and antenna selection of the Extreme CPE.

- **Configured Bandwidth** – Describes the configured bandwidth in megahertz.
- **Configured Tx Antenna Selection** – Describes the configured transmission antenna selection.
- **Configured Rx Antenna Selection** – Describes the configured receive antenna selection.
- **Configured Rx Attenuator Parameters** – Describes the configured receive signal after attenuation.
- **Current Bandwidth** – Describes the current bandwidth of the WiMAX link.

- **Current Tx Antenna Selection** – Describes the current transmission antenna selection.
- **Current Rx Antenna Selection** – Describes the current receive antenna selection.
- **Current Rx Attenuator Parameters** – Describes the current receive attenuator parameters.

Show All parameters, Registration parameters

---

|                     |                        |
|---------------------|------------------------|
| Configure User Name | 001122334456@WiMax.com |
| Actual User Name    | 001122334456@WiMax.com |
| Organization        |                        |
| Address             |                        |
| Country             |                        |
| Authentication      | EAP TTLS               |

**Figure 4-8: Show All - Registration Parameters**

**REGISTRATION PARAMETERS** – The Show All - Registration Parameters page displays information on the authentication parameters required to support provisioning on the unit.

- **Configure User Name** – Describes the configured user name for the unit.
- **Actual User Name** – Describes the current name being used to identify the user of the unit.
- **Organization** – Describes the WiMAX subscriber name.
- **Address** – Describes the contact information for the WiMAX subscriber.
- **Country** – Describes the country of operation.
- **Authentication** – Describes the method of authentication being used to secure the WiMAX connection.

Show All parameters, ATPC

---

|                 |          |
|-----------------|----------|
| Last Tx Rate    | 0.000000 |
| Optimal Rx Rate | 0.000000 |
| ATPC            | Disable  |
| Tx Power        | 0        |

**Figure 4-9: Show All - ATPC**

**ATPC** – The Show All - ATPC (Automatic Transmitter Power Control) page displays information on the transmitted signal.

- **Last Tx Rate** – Describes the last detected transmission rate.
- **Optimal Rx Rate** – Describes the transmission rate best suited to the connection.
- **ATPC** – Describes the level of automatic transmitter power control.
- **Tx Power** – Describes the transmission power level.

Show All parameters, Service Parameters

---

|                    |      |
|--------------------|------|
| Service Line Count | 8    |
| Operation Mode     | IPCS |

**Figure 4-10: Show All - Service Parameters**

**SERVICE PARAMETERS** – The Show All - Service Parameters page displays information on WiMAX service related capabilities.

- **Service Line Count** – Describes the service line count.
- **Operation Mode** – Describes the operation mode of the Extreme CPE.



---

## Chapter 5 - Unit Control

### In This Chapter:

- “Introduction” on page 56
- “Show Unit Control” on page 57
- “Reset” on page 61
- “Change Password” on page 62
- “Software Version Control” on page 63
- “Configuration Control” on page 65
- “TM and PM File Upload Control” on page 67
- “Ethernet Operation Mode” on page 68

## 5.1 Introduction

The Unit Control menu enables resetting the unit, reverting to the default configuration, changing the password, configuring the operation mode of the Ethernet port, and selecting the running software version. It also enables you to download a new software version.

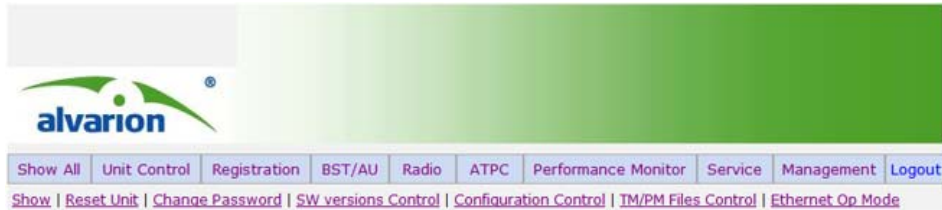

**Figure 5-11: Unit Control Menu**



## 5.2 Show Unit Control

The Show All page displays the show parameters for Unit Control, Registration, Base Station ID (BSID), Radio, Multi rate, ATPC and Service.

Show All parameters,Unit Control

|   |                                     |
|---|-------------------------------------|
| SU Type                                 | CPE Pro SQ                          |
| CPE Family                              | Sequans                             |
| Serial Number                           | RF_SN                               |
| MAC Address                             | 00:12:0A:66:66:66                   |
| MAC Address Control Number              | 14                                  |
| Radio Band                              | 5.XGHz                              |
| Hardware Version                        | R0A                                 |
| Hardware Configuration                  | ODU201                              |
| RF Version                              | PMC1.7                              |
| SU Interface Type                       | 1D                                  |
| Radio Type                              | 1 Rx , 1 Tx                         |
| Antenna Type                            | V Antenna                           |
| Ethernet Port Auto Negotiation          | Enable                              |
| Ethernet Port Speed & Duplex            | 100 Mbps Full duplex                |
| Operation Mode                          | IPCS                                |
| Unit Status                             | Searching for Base Station          |
| SW Boot Version                         | 0.0.2.0                             |
| Main SW File Name                       | X_AWB_0_0_2_0.app                   |
| Main SW Version                         | 0.0.2.0                             |
| Shadow SW File Name                     | X_AWB_0_0_2_0.app                   |
| Shadow SW Version                       | 0.0.2.0                             |
| Running From                            | Main                                |
| TFTP Server IP address(for SW download) | 192.168.254.250                     |
| SW File Name                            | K2_OD210_Firmware.bz                |
| Configuration File Upload Name          | SU_UPLOAD_CFG                       |
| Configuration File Download Name        | SU_DOWNLOAD_CFG                     |
| List of TM&PM Files gathered            | 00120A666666_02_01_1970_01_33_18_06 |

Figure 5-12: Unit Control - Show

**UNIT CONTROL** – The Show All - Unit Control menu provides information on the default system configuration and radio type.

- **SU Type** – Describes the service unit (SU) type.
- **CPE Family** – Describes the primary chipset of the Extreme CPE.

- **Serial Number** – Describes the serial number of the Extreme CPE unit. This number can be used to determine the identity of the subscriber unit by the base station operator.
- **MAC Address** – Describes the physical layer address of the LAN port. The WAN port MAC address can be determined by adding “1” to the LAN port MAC address.
- **MAC Address Control Number** – Displays the MAC address control number.
- **Radio Band** – Describes the radio band in use. The radio band for the Extreme CPE is 5.x.
- **Hardware version** – Describes the revision of hardware in use.
- **Hardware configuration** – Describes the identity of the current hardware configuration by serial number.
- **RF version** – Describes the radio frequency (RF) or rate of oscillation of the electrical circuit.
- **SU Interface Type** – Describes the number of ports available on the interface. “D” refers to data ports, “V” refers to VoIP ports, with a prefix number in use as a quantifier.
- **Radio Type** – Describes the receive (Rx) and transmit (Tx) capacity of the radio.
- **Antenna Type** – Describes the antenna type employed by the Extreme CPE.
- **Ethernet Port Auto Negotiation** – Describes the Ethernet port auto negotiation enable/disable state.
- **Ethernet Port Speed & Duplex** – Describes the speed and duplex capabilities to which the Ethernet port has been set to.
- **Operation Mode** – Describes the operation mode of the Extreme CPE, either IPCS or ETHCS where IPCS refers to transparent delivery of IPv4 packets and ETHCS refers to transparent delivery of tagged 802.3 packets over Ethernet.
- **Unit Status** – Describes the connectivity status of the Extreme CPE to the base station.

- **SW Boot Version** – Describes the current software boot version file.
- **Main SW File Name** – Describes the name of the current firmware.
- **Main SW Version** – Describes the version of the current firmware.
- **Shadow SW File Name** – Describes the name of the secondary, or shadow, firmware file.
- **Shadow SW Version** – Describes the version of the shadow firmware file.
- **Running From** – Describes the firmware file being used by the Extreme CPE as a running configuration. (Options: Main, or Shadow)
- **TFTP Server IP address(for SW download)** – Describes the TFTP server IP address that is being used for firmware download.
- **SW File Name** – Describes the name of the download firmware file from the TFTP server.
- **Configuration File Upload Name** – Describes the name of the uploaded configuration file.
- **Configuration File Download Name** – Describes the name of the current configuration file.
- **List of TM&PM Files Gathered** – Describes the TM (Traffic Monitoring) and PM (Performance Monitoring) files that the unit has detected.

License Type

| POTS 1        | POTS 2        | MIR=2Mbps | MIR=6Mbps     | Unlimited MIR | Ethernet CS   | VPN over IP CS | Switching Antenna |
|---------------|---------------|-----------|---------------|---------------|---------------|----------------|-------------------|
| Not Available | Not Available | Available | Not Available | Not Available | Not Available | Not Available  | Not Available     |

**LICENSE TYPE** – Describes the availability of VoIP ports, operator preset maximum information rates (MIR), Ethernet status, virtual private networks (VPN) status and switching antenna status.

- **POTS1/2** – Describes the availability status of the VoIP plain old telephone service (POTS) ports. ‘Available’ indicates that the specified VoIP port is open for use.
- **MIR=2Mbps** – Describes the operator preset maximum information rate (MIR) state per subscriber at 2Mbps upload/download.
- **MIR=6Mbps** – Describes the operator preset maximum information rate (MIR) state per subscriber at 6Mbps upload/download.
- **Unlimited MIR** – Describes if the operator preset maximum information rate (MIR) is unlimited in upload/download bandwidth, or unavailable to the subscriber.
- **Ethernet CS** – Describes the Ethernet convergence sublayer (CS) status.
- **VPN over IP CS** – Describes the status of the virtual private network (VPN) over internet protocol (IP) convergence sublayer.
- **Switching Antenna** – Describes the status of the switching antenna.

## 5.3 Reset

The Reset page allows you to reset the Extreme CPE for configuration changes to take effect.

### NOTE



Resetting the unit does not restore factory defaults.

### Reset Unit

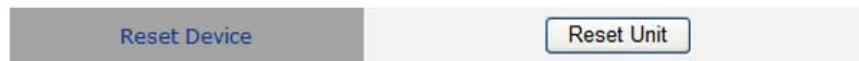

**Figure 5-13: Unit Control - Reset Unit**

**RESET UNIT** – Resetting the unit reboots the device.

- **Reset Unit** – Click 'Reset Unit' to reboot the Extreme CPE.

## 5.4 Change Password

The Change Password page enables you to create a new password for access to the Extreme CPE. It is advisable to change the factory default password upon receipt of your Extreme CPE device.

**Change Password**

---

|                       |                      |
|-----------------------|----------------------|
| Old Password:         | <input type="text"/> |
| New Password:         | <input type="text"/> |
| Confirm New Password: | <input type="text"/> |

**Figure 5-14: Unit Control - Change Password**

**CHANGE PASSWORD** – Allows changing of the current user password for security purposes.

- **Old Password** – Prompts you to enter your current password.
- **New Password** – Prompts you to enter a new password. (Length: 1-20 characters, cannot include the characters '<>?:;,."{}|\|,' and is case sensitive).
- **Confirm New Password** – Prompts you to re-enter the new password.
- **Save New Password** – Clicking 'Save New Password' saves the new password and deletes the old password.
- **Refresh** – Clicking 'Refresh' clears all information boxes.

## 5.5 Software Version Control

The Software Version Control page allows you to download new runtime software for the Extreme CPE, run a backup runtime image (or shadow), reset the device and select the current running configuration file.

**SW Versions Control**

---

|                        |                       |
|------------------------|-----------------------|
| Main SW File Name      | X_AWB_0_0_2_0.app     |
| Main SW Version        | 0.0.2.0               |
| Shadow SW File Name    | X_AWB_0_0_2_0.app     |
| Shadow SW Version      | 0.0.2.0               |
| Running From           | Main                  |
| TFTP Server IP Address | 192 . 168 . 254 . 250 |
| SW File Name           | K2_OD210_Firmware.bz  |

**Figure 5-15: Unit Control - Software Version Control**

**SW VERSIONS CONTROL** – Enables uploading and setting of main and shadow software versions.

- **Main SW File Name** – Describes the file name of the currently loaded software.
- **Main SW Version** – Describes the version of software currently in use.
- **Shadow SW File Name** – Describes the shadow or backup software loaded into memory for failover measures.
- **Shadow SW Version** – Describes the shadow software version.
- **Running From** – Describes if the unit is running Main or Shadow software on bootup.

- **TFTP Server IP Address** – Allows the user to enter the IP address of the TFTP server from which to download code to the unit.
  
- **SW File Name** – Allows the user to enter the file name of the software file to be downloaded to the unit.
  
- **SW Download** – Click ‘SW Download’ to download user specified software to the unit from the TFTP IP address. The image downloaded will overwrite the current shadow image.
  
- **Reset and Run from Shadow** – Click ‘Reset and Run from Shadow’ to reboot the unit and run from the shadow image.
  
- **Set Running Version as Main** – Click ‘Set Running Version as Main’ to make the currently running software configuration the main image.
  
- **Refresh** – Click ‘Refresh’ to reload the current page and parameters associated with it.



## 5.6 Configuration Control

The Configuration Control page allows you to specify an IP address from which to upload or download a running configuration file. It also allows you to restore the factory default TFTP server address.

**Configuration Control**

---

|                                  |   |
|----------------------------------|---|
| Configuration Upload File Name   | <input type="text" value="SU_UPLOAD_CFG"/>  |
| Configuration Download File Name | <input type="text" value="SU_DOWNLOAD_CFG"/>  |
| TFTP Server IP Address           | <input type="text" value="192"/> <input type="text" value="168"/> <input type="text" value="254"/> <input type="text" value="250"/> |
| Chose upload/download            | <input checked="" type="radio"/> Upload <input type="radio"/> Download  |

**Figure 5-16: Unit Control - Configuration Control**

**CONFIGURATION CONTROL** – Use the configuration control page to transfer running configuration files.

- **Configuration Upload File Name** – Allows the user to specify the configuration upload file name for copying to the TFTP server.
- **Configuration Download File Name** – Allows the user to specify the configuration download file name for downloading from the TFTP server.
- **TFTP Server IP Address** – Specifies a TFTP server IP address for upload/download.
- **Chose upload/download** – Selects to either upload to, or download from the specified TFTP server.
- **Action** – Performs the selected upload or download procedure.
- **Refresh** – Reloads the page and the parameters associated with it.
- **Set Factory Defaults** – Resets the factory default configuration file path settings from the TFTP server to the Extreme CPE.



**NOTE**

Selecting this option does not perform a factory reset. It simply makes available the TFTP IP path of the default factory configuration file settings to the unit. Selecting 'Action' will implement the file settings.

## 5.7 TM and PM File Upload Control

The TM (Traffic Monitoring) & PM (Performance Monitoring) File Upload Control page enables the user to define parameters related to uploading the TM & PM files where link quality data is stored, to the TFTP server directory and to initiate the upload operation.

**TM & PM File Upload Control**

---

|                              |                                       |
|------------------------------|---------------------------------------|
| TM & PM files                | 001122334455_01_01_1970_06_46_19_31 ▾ |
| Local TFTP Server IP Address | 192 . 168 . 254 . 250                 |

**Figure 5-17: Unit Control - TM & PM File Upload Control**

**TM & PM FILE UPLOAD CONTROL** – Traffic and performance monitoring allow for a variety of statistical data to be collected about the Extreme CPE and its WiMAX link.

- **TM & PM Files** – Specifies the available TM and PM files from the drop down menu for uploading to the TFTP server.
- **Local TFTP Server IP Address** – Specifies a local TFTP server IP address from which to upload the TM and PM files.
- **Perform Action** – Clicking ‘Perform Action’ initiates the upload procedure.

## 5.8 Ethernet Operation Mode

The Ethernet Op Mode page enables configuration of the Ethernet connection.

**Current Parameters and Status**

---

|                       |   |
|-----------------------|---|
| Auto Negotiation      | Enable  |
| Speed & Duplex        | 100 Mbps Full duplex  |
| Configured Parameters |   |
| Auto Negotiation      | <input checked="" type="radio"/> Disable <input type="radio"/> Enable |
| Speed & Duplex        | 100 Mbps Full duplex ▼  |

**Figure 5-18: Unit Control - Ethernet Op Mode**

**CURRENT PARAMETERS AND STATUS** – Specifies the current Ethernet port settings.

- **Auto Negotiation** – Describes the auto negotiation status of the Ethernet port.
- **Speed & Duplex** – Describes the speed and duplex capabilities set for the Ethernet port.
- **Configured Parameters** –
- **Auto Negotiation** – Select to enable or disable auto-negotiation on the Ethernet port.
- **Speed & Duplex** – If auto-negotiation is disabled, select from the drop down menu the speed and duplex setting for the Ethernet port.
- **Apply** – Click ‘Apply’ to save and apply settings to the port.

---

## Chapter 6 - Registration

### In This Chapter:

- [“Introduction” on page 70](#)
- [“Show Registration Parameters” on page 71](#)
- [“Registration Configuration” on page 72](#)

## 6.1 Introduction

The Registration menu enables the user to enter station information about for the Extreme CPE, such as user name, password, country of operation and organisation. It also enables the user to select the authentication method used to authenticate the Extreme CPE with the base station.

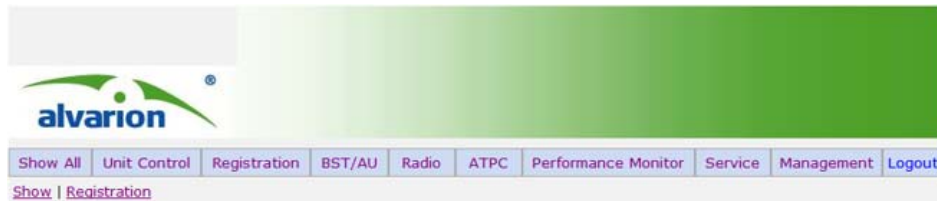

**Figure 6-19: Registration Menu**

## 6.2 Show Registration Parameters

The Show Registration Parameters page displays the show registration parameters such as configured user name and the country of operation of the Extreme CPE.

| Show All parameters, Registration parameters |                        |
|--|------------------------|
| Configure User Name                          | 001122334456@WiMax.com |
| Actual User Name                             | 001122334456@WiMax.com |
| Organization                                 |                        |
| Address                                      |                        |
| Country                                      |                        |
| Authentication                               | EAP TTLS               |

**Figure 6-20: Registration - Show**

**REGISTRATION PARAMETERS** – The Show All - Registration Parameters page displays information on the authentication parameters required to support provisioning on the unit.

- **Configure User Name** – Describes the configured user name for the unit.
- **Actual User Name** – Describes the name being used to identify the actual user of the unit.
- **Organization** – Describes the WiMAX subscriber name.
- **Address** – Describes the contact information for the WiMAX subscriber.
- **Country** – Describes the country of operation.
- **Authentication** – Describes the method of authentication being used to secure the WiMAX connection.

## 6.3 Registration Configuration

The User Registration page allows the user to define registration parameters such as configured user name, password, organisation and the country of operation of the Extreme CPE. It also allows the user to select the authentication method.

**User Registration**

---

|                  |   |
|------------------|---|
| User Name        | <input type="text" value="001122334456@WiMax.c"/>   |
| Password         | <input type="text"/>  |
| Password Confirm | <input type="text"/>  |
| Organization     | <input type="text"/>  |
| Address          | <input type="text"/>  |
| Country          | <input type="text"/>  |
| Authentication   | <input type="radio"/> N/A <input checked="" type="radio"/> EAP TTLS <input type="radio"/> EAP TLS |

**Figure 6-21: Registration - User Registration Configuration**

**USER REGISTRATION** – Allows the user to enter information on the authentication parameters required to support provisioning on the unit.

- **User Name** – Allows the user to enter a user name for the unit, in the form someone@WiMAX.com.
- **Password** – Allows the user to set a password for registration purposes.
- **Password Confirm** – Prompts the user to re-enter the password.
- **Organization** – Enter the WiMAX subscriber name.
- **Address** – Enter the contact information for the WiMAX subscriber.
- **Country** – Enter the country of operation.
- **Authentication** – Allows the user to describe the method of authentication being used to secure the WiMAX connection. (Options: none; EAP TTLS; EAP TLS)



---

## Chapter 7 - Base Station Scanning

### In This Chapter:

- “Introduction” on page 74
- “BS Scanning” on page 75

## 7.1 Introduction

The base station/access unit (BST/AU) page displays base station (BST) and access unit (AU) information for the the base station that the Extreme CPE connects to. It also enables configuration of BST/AU identification, network masks, and WiMAX mobility mode.



**Figure 7-22: BS Scanning Menu**

## 7.2 BS Scanning

The BS AU scanning page allows the user to scan for a nearby base station, specify a frequency, a preferred bandwidth, and frame duration.

The table will display all base stations that match the criteria entered.



### NOTE

The access unit will search for the preferred base station first, but the displayed best base station might not be that which is specified as preferred if the preferred base station is unavailable.

Best BST/AU Parameters and Best BST/AU Table

|                           |                   |
|---------------------------|-------------------|
| Configured Best BS ID     | 00.00.00.00.00.00 |
| Current Best BS ID        | 00.00.00.00.00.00 |
| Current Best BS RSSI(dBm) | 0                 |
| Current Best BS SNR(dB)   | 0                 |
| Current Bandwidth         | 0                 |

Figure 7-23: BST/AU - Best BST/AU

**BEST BS/AU** – The Best BS/AU page displays information on the base station identity (BSID), as well as signal strength indication, noise ratio and bandwidth of the WiMAX connection.

- **Configured Best BS ID** – Describes the configured base station identity, in the form xx.xx.xx.xx.xx.xx.
- **Current Best BS ID** – Describes the identity of the best base station, in the form xx.xx.xx.xx.xx.xx.
- **Current Best BS RSSI (dBm)** – Describes the receive signal strength indicator of the optimal WiMAX link, in decibels per milliwatt.
- **Current Best BS SNR (dB)** – Describes the signal to noise ratio of the optimal WiMAX link, in decibels.
- **Current Bandwidth** – Describes the bandwidth of the optimal WiMAX link.

Selected BST/AU Parameters

|                       |                   |
|-----------------------|-------------------|
| Selected BST/AU ID    | 00.00.00.00.00.00 |
| Selected Rx Frequency | 0                 |
| Rx RSSI(dBm)          | 0                 |
| Rx SNR(dB)            | 0                 |
| Selected BW           | 0                 |

Figure 7-24: BST/AU - Selected BST/AU Parameters

**SELECTED BST/AU PARAMETERS** – The Selected BST/AU Parameters page describes the BSID, frequency, signal strength, noise ratio and identity of the selected base station.

- **Selected BST/AU ID** – Describes the configured base station identity, in the form xx.xx.xx.xx.xx.xx.
- **Frequency** – Describes the selected receive signal frequency.
- **Rx RSSI (dBm)** – Describes the receive signal strength indicator of the WiMAX link, in decibels per milliwatt.
- **Rx SNR (dB)** – Describes the signal to noise ratio of the WiMAX link, in decibels.
- **Selected Bandwidth** – Describes the bandwidth of the WiMAX link.

Best BST/AU Table

| BS ID | Rx Frequency(MHz) | SNR(dB) | Bandwidth |
|-------|-------------------|---------|-----------|
|-------|-------------------|---------|-----------|

Figure 7-25: BST/AU - Best BST/AU Table

**BEST BST/AU TABLE** – The Best BST/AU Table describes the optimal base station identity, frequency, signal to noise ratio and bandwidth of the selected base station.

- **BS ID** – Describes the optimal base station identity (BSID).
- **Rx Frequency (MHz)** – Describes the optimal base station receive frequency for the WiMAX link, in megahertz.
- **SNR(dB)** – Describes the optimal signal to noise ratio of the WiMAX link, in decibels.

- **Bandwidth** – Describes the optimal bandwidth of the WiMAX link.

### BST/AU and Preferred BST/AU Parameters

|                          |   |
|--------------------------|---|
| BST/AU ID                | <input type="text" value="0"/> <input type="text" value="0"/> <input type="text" value="0"/> <input type="text" value="0"/> <input type="text" value="0"/> <input type="text" value="0"/> |
| BST/AU ID Mask           | <input type="text" value="0"/> <input type="text" value="0"/> <input type="text" value="0"/> <input type="text" value="0"/> <input type="text" value="0"/> <input type="text" value="0"/> |
| Preferred BST/AU ID      | <input type="text" value="0"/> <input type="text" value="0"/> <input type="text" value="0"/> <input type="text" value="0"/> <input type="text" value="0"/> <input type="text" value="0"/> |
| Preferred BST/AU ID Mask | <input type="text" value="0"/> <input type="text" value="0"/> <input type="text" value="0"/> <input type="text" value="0"/> <input type="text" value="0"/> <input type="text" value="0"/> |
| Mobility Mode            | <input checked="" type="radio"/> nomadic <input type="radio"/> mobile   |

**Figure 7-26: BST/AU - BST/AU and Preferred BST/AU Parameters**

**BEST BST/AU TABLE** – The BST/AU and Preferred BST/AU Parameters page describes the user configured base station identity, mask, preferred base station identity and mask, as well as the mobility mode.

- **BST/AU ID** – Allows the user to configure the base station identity.
- **BEST/AU ID MASK** – Allows the user to configure the base station mask.
- **Preferred BST/AU ID** – Allows the user to configure the preferred base station identity.
- **Preferred BST/AU ID Mask** – Allows the user to configure the preferred base station mask.
- **Mobility Mode** – Selects the mobility mode of the WiMAX radio. (Options: nomadic and mobile)
- **Apply** – Applies the specified changes.



---

## Chapter 8 - Radio Parameters

### In This Chapter:

- [“Introduction” on page 80](#)
- [“Radio Parameters” on page 81](#)
- [“Frequency Scanning” on page 82](#)
- [“Antenna Selection” on page 86](#)

## 8.1 Introduction

The radio page allows you to configure frequency scanning parameters for the Extreme CPE, view the scanning table and antenna selection.

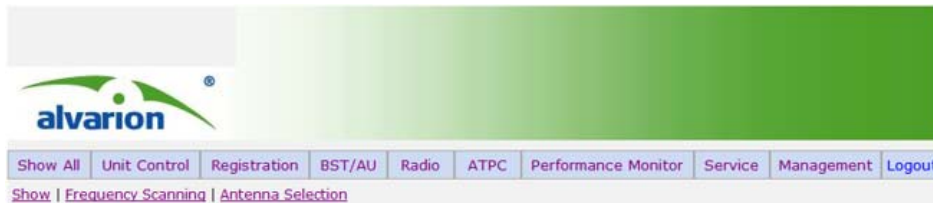

**Figure 8-27: Radio Menu**



## 8.2 Radio Parameters

The Show Radio Parameters page displays the parameters of the radio settings.

Show All parameters, Radio parameters

|                                     |       |
|-------------------------------------|-------|
| Configured Bandwidth                | 10Mhz |
| Configured TX Antenna Selection     | 0     |
| Configured RX Antenna Selection     | 0     |
| Configured Rx Attenuator parameters | 0     |
| Current Bandwidth                   | 0     |
| Current TX Antenna Selection        | 0     |
| Current RX Antenna Selection        | 0     |
| Current Rx Attenuator parameters    | 0     |

**Figure 8-28: Show All - Radio Parameters**

**RADIO PARAMETERS** – The Show All - Radio Parameters page displays information on the bandwidth and antenna selection of the Extreme CPE.

- **Configured Bandwidth** – Describes the configured bandwidth in megahertz.
- **Configured Tx Antenna Selection** – Describes the configured transmission antenna selection.
- **Configured Rx Antenna Selection** – Describes the configured receive antenna selection.
- **Configured Rx Attenuator Parameters** – Describes the configured receive signal after attenuation.
- **Current Bandwidth** – Describes the current bandwidth of the WiMAX link.
- **Current Tx Antenna Selection** – Describes the current transmission antenna selection.
- **Current Rx Antenna Selection** – Describes the current receive antenna selection.
- **Current Rx Attenuator Parameters** – Describes the current receive attenuator parameters.

## 8.3 Frequency Scanning

Frequency Scanning allows the user to enter frequencies with which to scan for nearby base stations.

**Frequency Scanning Parameters**

---

|                                   |   |
|-----------------------------------|---|
| Start Rx Frequency(MHz)           | <input type="text" value="5400"/>   |
| End Rx Frequency(MHz)             | <input type="text" value="5950"/>   |
| Scanning Main Step(KHz)           | <input type="text" value="15"/>   |
| Scanning Intermediate Steps (KHz) | <input checked="" type="checkbox"/> B0 Start freq scan <input type="checkbox"/> B1 125KHz<br><input type="checkbox"/> B2 250KHz <input type="checkbox"/> B3 375KHz<br><input type="checkbox"/> B4 500KHz <input type="checkbox"/> B5 625KHz<br><input type="checkbox"/> B6 750KHz <input type="checkbox"/> B7 1250KHz |
| Bandwidth(MHz)                    | <input type="text" value="10MHz"/> <input type="button" value="v"/>   |
|                                   | <input type="button" value="Apply"/>  |
| Discrete Frequencies              | <input type="text" value="100 Mhz"/> <input type="button" value="v"/> <input type="button" value="Delete select"/>  |
| Delete All Discrete Frequencies   | <input type="button" value="Delete All"/>   |

**Figure 8-29: Radio - Frequency Scanning Parameters**

**FREQUENCY SCANNING PARAMETERS** – The Frequency Scanning Parameters page specifies the frequency, scanning steps and bandwidth for purposes of scanning for nearby base stations.

- **Start Rx Frequency(MHz)** – Specifies the frequency at which to start scanning, in megahertz.
- **End Rx Frequency(MHz)** – Specifies the frequency at which to stop scanning, in megahertz.
- **Scanning Main Step(KHz)** – Specifies the main step in the frequency scanning process using the formula  $F(N) = \text{Start Frequency} + N * \text{Main Step}$ , for  $N = 0, 1, 2, \dots$
- **Scanning Intermediate Steps(KHz)** – Specifies the intermediate step in the scanning process using the formula  $F(N) = \text{Start Frequency} + N * (\text{Main Step})$ ,  $\text{Start Frequency} + N * (\text{Main Step} + \text{Intermediate Step})$ , for  $N = 0, 1, 2, \dots$
- **Bandwidth(MHz)** – Specifies the bandwidth for the scanning process.

- **Apply** – Saves the specified bandwidth.
- **Discrete Frequencies** – Delete a selected discrete frequency.
- **Delete All Discrete Frequencies** – Deletes all discrete frequencies.

**Discrete Scanning Frequencies**

---

|                             |                      |        |
|-----------------------------|----------------------|--------|
| Update Discrete Frequencies | <input type="text"/> | Update |
| Add One Discrete Frequency  | <input type="text"/> | Add    |

**Figure 8-30: Radio - Discrete Scanning**

**DISCRETE SCANNING FREQUENCIES** – Allows the user to enter up to 10 discrete frequencies to scan for a base station with. The frequencies must comply with the supported hardware bands.

- **Update Discrete Frequencies** – Enter up to 10 discrete frequencies, separated by commas. The resolution used is 125KHz.
- **Update** – Adds the frequencies and replaces any previous discrete frequency.
- **Add One Discrete Frequency** – Adds one discrete frequency to the list.

### Scanning Table

Full Scanning table list

| Rx Frequency(MHz) | Bandwidth |
|-------------------|-----------|
| 5400              | 10Mhz     |
| 5415              | 10Mhz     |
| 5430              | 10Mhz     |
| 5445              | 10Mhz     |
| 5460              | 10Mhz     |
| 5475              | 10Mhz     |
| 5490              | 10Mhz     |
| 5505              | 10Mhz     |
| 5520              | 10Mhz     |
| 5535              | 10Mhz     |
| 5550              | 10Mhz     |
| 5565              | 10Mhz     |
| 5580              | 10Mhz     |
| 5595              | 10Mhz     |
| 5610              | 10Mhz     |
| 5625              | 10Mhz     |

**Figure 8-31: Radio - Scanning Table**

**SCANNING TABLE** – The Scanning Table displays all frequencies and bandwidths scanned by the Extreme CPE.

- **Rx Frequency(MHz)** – Describes the receive frequency scanned.
- **Bandwidth** – Describes the receive bandwidth scanned.

Best BS Scanning table list

| BS ID  | Rx Frequency(MHz) | SNR(dB) | Bandwidth |
|--|-------------------|---------|-----------|
| <input type="button" value="Update Scanning Table"/> |                   |         |           |
| <input type="button" value="Clear Best AU Table"/>   |                   |         |           |
| <input type="button" value="Force Full Scanning"/>   |                   |         |           |

**Figure 8-32: Radio - Best BS Scanning Table List**

**SCANNING TABLE** – The Scanning Table displays all frequencies and bandwidths scanned by the Extreme CPE.

- **BS ID** –

- **Rx Frequency(MHz) –**
- **SNR(dB) –**
- **Bandwidth –**
- **Update Scanning Table –**
- **Clear Best AU Table –**
- **Force Full Scanning –**

## 8.4 Antenna Selection

Antenna Selection displays the current antenna deployed by the Extreme CPE.

| Antenna Selection |  |
|-------------------|--|
| Radio Status      | 1Rx / 1Tx Si / ODU not switching antenna |
| Antenna           | No selection                             |

**Figure 8-33: Radio - Antenna Selection**

**ANTENNA SELECTION** – The Antenna Selection page displays information on the antenna in use by the Extreme CPE.

- **Radio Status** – Describes the status of the WiMAX radio.
- **Antenna** – Describes the selection of antenna.

---

## Chapter 9 - ATPC

### In This Chapter:

- “Introduction” on page 88
- “ATPC Parameters” on page 89
- “ATPC Configuration” on page 90

## 9.1 Introduction

The Adaptive Transmission Power Control (ATPC) page displays the WiMAX transmit signal levels and allows configuration of the ATPC algorithm or disabling of the feature.

ATPC provides system designers with the ability to dynamically control the transmission power, and offers a register to specify the transmission power level during runtime. It is desirable to specify the minimum transmission power level that achieves the required communication reliability for the sake of saving power and increasing the system lifetime.

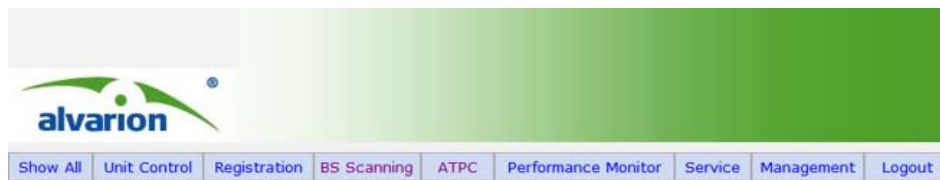

**Figure 9-34: ATPC Menu**



## 9.2 ATPC Parameters

The Show All Parameters, ATPC page displays the transmit and receive data levels.

Show All parameters, ATPC

---

|                 |          |
|-----------------|----------|
| Last Tx Rate    | 0.000000 |
| Optimal Rx Rate | 0.000000 |
| ATPC            | Disable  |
| Tx Power        | -7       |

**Figure 9-35: ATPC - Show Parameters**

**ATPC** – The Show All - ATPC (Automatic Transmitter Power Control) page displays information on the transmitted signal.

- **Last Tx Rate** – Describes the last detected transmission rate.
- **Optimal Rx Rate** – Describes the transmission rate best suited to the connection.
- **ATPC** – Describes the level of automatic transmitter power control.
- **Tx Power** – Describes the transmission power level.

## 9.3 ATPC Configuration

The Multi rate and ATPC Parameters page enables the user to view the transmission (Tx) and reception (Rx) power levels, their optimum levels, radio band, and allows enabling or disabling of the ATPC feature, as well as setting of the the transmission power level.

Once enabled the ATPC feature implements a power control algorithm for the WiMAX network. The result of applying ATPC is that every node knows the proper transmission power level to use for each of its neighbours, and every node maintains good link qualities with its neighbours by dynamically adjusting the transmission power through on-demand feedback packets.

Uniquely, ATPC adopts a feedback-based and pairwise transmission power control. By collecting the link quality history, ATPC builds a model for each neighbor of the node. This model represents an in-situ correlation between transmission power levels and link qualities. With such a model, ATPC tunes the transmission power according to monitored link quality changes. The changes of transmission power level reflect changes in the surrounding environment.

**Multi rate and ATPC Parameters**

---

|                      |   |
|----------------------|---|
| Last Tx Rate         | 0.000000  |
| Optimal Rx Rate      | 0.000000  |
| ATPC                 | Disable   |
| Tx Power             | -7  |
| Current Radio Band   | 5.XGHz  |
| Tx Power Range (dBm) | 21 dBm ~ -26 dBm                                      |
| ATPC:                | Disable <input type="button" value="v"/>              |
| Set Tx Power:        | <input type="text" value="-7"/> dBm(minimum: -26 dBm) |

**Figure 9-36: ATPC - Configuration**

**MULTI RATE / ATPC** – The Multi rate and ATPC Parameters page displays information on the transmitted and received signals, allows enabling of the ATPC algorithm and setting of the transmission power level.

- **Last Tx Rate** – Describes the last transmission power rate.
- **Optimal Rx Rate** – Describes the optimal receive signal strength.

- **ATPC** – Describes the status of the ATPC algorithm.
- **Tx Power** – Describes the mean transmission power rate.
- **Current Radio Band** – Describes the current radio band in GHz.
- **Tx Power Range (dBm)** – Describes the transmission power range in dBm.
- **ATPC** – Allows the user to enable or disable the ATPC algorithm.
- **Set Tx Power** – Allows the user to set the transmission power rate.
- **Apply** – Applies all modified parameters.



---

## Chapter 10 - Performance Monitor

### In This Chapter:

- “Introduction” on page 94
- “Link Quality Counters” on page 95
- “Ethernet Counters” on page 97
- “Link Historical” on page 99
- “Ethernet Historical” on page 101
- “Integration Time” on page 104
- “Spectrum Analyzer” on page 105

## 10.1 Introduction

The Performance Monitor Page displays performance monitoring of link quality, Ethernet counters, link history, Ethernet history, integration times and spectrum analyser for fault management. The Extreme CPE collects data on a regular basis and is able to deliver the data to the Access Control Server NMS (Network Management Station) upon request.



**Figure 10-37: Performance Monitor Menu**

## 10.2 Link Quality Counters

The Link Quality On-Line Display page displays the SNR (signal to noise ratio), RSSI (receive signal strength indication), and Tx/Rx data levels.

|                      |          |
|----------------------|----------|
| DL Median SNR (dB)   | 0        |
| DL Median RSSI (dBm) | -103     |
| Median Rx Rate       | 0.000000 |
| Last Rx Rate         | 0.000000 |
| Maximum Rx Rate      | 0.000000 |
| Minimum Rx Rate      | 0.000000 |
| UL SNR (dB)          | 0        |
| UL RSSI (dBm)        | -103     |
| Median Tx Rate       | 0.000000 |
| Last Tx Rate         | 0.000000 |
| Maximum Tx Rate      | 0.000000 |
| Minimum Tx Rate      | 0.000000 |

**Figure 10-38: Performance Monitor - Link Quality**

**ONLINE LINK QUALITY** – The Link Quality On-Line Display displays information related to the quality of the link between the Extreme CPE and the base station.

- **DL Median SNR (dB)** – Displays the median level of the downlink (DL) Signal-to-Noise (SNR) ratio, measured over a duration of two seconds. The figure will refresh every two seconds.
- **DL Median RSSI (dBm)** – Displays the median level of the downlink Receive Signal Strength Indicator (RSSI), measured over a duration of two seconds. The figure will refresh every two seconds.
- **Median Rx Rate** – Displays the current average data rate of the WiMAX link in Megabits per second, measured over a duration of two seconds. The figure will refresh every two seconds.
- **Last Rx Rate** – Displays the strength of the received signal in Megabits per second, measured over a duration of two seconds. The figure will refresh every two seconds.

- **Maximum Rx Rate** – Displays the upper maximum of the received signal strength detected over a duration of two seconds. The figure will refresh every two seconds.
- **Minimum Rx Rate** – Displays the lowest received signal strength detected over a duration of two seconds. The figure will refresh every two seconds.
- **UL SNR (dB)** – Displays the median uplink (UL) Signal-to-Noise Ratio received by the base station, measured over a duration of two seconds. The figure will refresh every two seconds.
- **UL RSSI (dBm)** – Displays the median uplink Receive Signal Strength Indicator received by the base station, measured over a duration of two seconds. The figure will refresh every two seconds.
- **Median Tx Rate** – Displays the median transmit data rate of the Extreme CPE in Megabits per second, measured over a duration of two seconds. The figure will refresh every two seconds.
- **Last Tx Rate** – Displays the most recent transmit data rate of the Extreme CPE in Megabits per second, measured over the last two seconds. The figure will refresh every two seconds.
- **Maximum Rx Rate** – Displays the maximum receive data rate of the Extreme CPE in Megabits per second, measured over a duration of two seconds. The figure will refresh every two seconds.
- **Minimum Rx Rate** – Displays the minimum receive data rate of the Extreme CPE in Megabits per second, measured over a duration of two seconds. The figure will refresh every two seconds.



## 10.3 Ethernet Counters

The Ethernet On-Line Counters page displays RX and Tx levels for the Ethernet connection.

|                           |              |
|---------------------------|--------------|
| Rx LAN Port Bit Rate      | 5872.000000  |
| Rx LAN Packet Rate        | 5.500000     |
| Tx LAN Port Bit Rate      | 16328.000000 |
| Tx LAN Packet Rate        | 16328.000000 |
| Rx LAN Port Total Bytes   | 1468         |
| Rx LAN Port Total Packets | 11           |
| Tx LAN Port Total Bytes   | 4082         |
| Tx LAN Port Total Packets | 12           |
| Rx WAN Port Bit Rate      | 0.000000     |
| Rx WAN Packet Rate        | 0.000000     |
| Tx WAN Port Bit Rate      | 0.000000     |
| Tx WAN Packet Rate        | 0.000000     |
| Rx WAN Port Total Bytes   | 0            |
| Rx WAN Port Total Packets | 0            |
| Tx WAN Port Total Bytes   | 0            |
| Tx WAN Port Total Packets | 0            |

**Figure 10-39: Performance Monitor - Online Counters**

**ETHERNET ON-LINE COUNTERS** – The Ethernet On-Line Counters page describes the incremental statistical values of the LAN and WAN ports.

- **Rx LAN Port Bit Rate** – Displays the received bit rate of the Ethernet LAN port. The figure will refresh every two seconds.
- **Rx LAN Packet Rate** – Displays the received packet rate of the Ethernet LAN port. The figure will refresh every two seconds.
- **Tx LAN Port Bit Rate** – Displays the transmitted bit rate of the Ethernet LAN port. The figure will refresh every two seconds.
- **Tx LAN Packet Rate** – Displays the transmitted packet rate of the Ethernet LAN port. The figure will refresh every two seconds.
- **Rx LAN Port Total Bytes** – Displays the received byte rate of the Ethernet LAN port. The figure will refresh every two seconds.

- **Rx LAN Port Total Packets** – Displays the total received packets of the Ethernet LAN port. The figure will refresh every two seconds.
- **Tx LAN Port Total Bytes** – Displays the transmitted byte rate of the Ethernet LAN port. The figure will refresh every two seconds.
- **Tx LAN Port Total Packets** – Displays the total number of packets transmitted by the Ethernet LAN port. The figure will refresh every two seconds.
- **Rx WAN Port Bit Rate** – Displays the received bit rate of the WiMAX WAN port. The figure will refresh every two seconds.
- **Rx WAN Packet Rate** – Displays the received packet rate of the WiMAX WAN port. The figure will refresh every two seconds.
- **Tx WAN Port Bit Rate** – Displays the transmitted bit rate of the WiMAX WAN port. The figure will refresh every two seconds.
- **Tx WAN Packet Rate** – Displays the transmitted packet rate of the WiMAX WAN port. The figure will refresh every two seconds.
- **Rx WAN Port Total Bytes** – Displays the total bytes received on the WiMAX WAN port. The figure will refresh every two seconds.
- **Rx WAN Port Total Packets** – Displays the total packets received on the WiMAX WAN port. The figure will refresh every two seconds.
- **Tx WAN Port Total Bytes** – Displays the total bytes transmitted by the WiMAX WAN port. The figure will refresh every two seconds.
- **Tx WAN Port Total Packets** – Displays the total number of packets transmitted by the WiMAX WAN port. The figure will refresh every two seconds.

## 10.4 Link Historical

The Link Quality Historical Counters page allows you to set a start/stop time and date for monitoring WiMAX link quality statistics.

**Link Quality Historical Counters**

---

|                      |                             |
|----------------------|-----------------------------|
| Start time & date:   | 1970 / 01 / 01 00 : 00 : 00 |
| Stop time & date:    | 1970 / 01 / 01 01 : 00 : 00 |
| DL Median SNR (dB)   | 0                           |
| DL Median RSSI (dBm) | -103                        |
| Median Rx Rate       | 0.000000                    |
| Last Rx Rate         | 0.000000                    |
| Maximum Rx Rate      | 0.000000                    |
| Minimum Rx Rate      | 0.000000                    |
| UL SNR (dB)          | 0                           |
| UL RSSI (dBm)        | -103                        |
| Median Tx Rate       | 0.000000                    |
| Last Tx Rate         | 0.000000                    |
| Maximum Tx Rate      | 0.000000                    |
| Minimum Tx Rate      | 0.000000                    |

**Figure 10-40: Performance Monitor - Link Historical**

**LINK QUALITY HISTORICAL COUNTERS** – The Link Quality Historical Counters page allows the user to modify the time over which to monitor the WiMAX link and to display WiMAX receive/transmit link statistics. The user may configure up to 96 Historical Counters, the amalgamation of which will be displayed as averages in the display-only parameters below. Between the dates chosen a frequency of monitoring for information can be set on the Integration Time page.

- **Start Time & Date** – Allows the user to enter the year, month, day, hour, minute and second on which to start monitoring the WiMAX link.
- **Stop time & date** – Allows the user to enter the year, month, day, hour, minute and second on which to stop monitoring the WiMAX link.
- **DL Median SNR (dB)** – Displays the median downlink (DL) Signal-to-Noise Ratio for the selected time period.

- **DL Median RSSI (dBm)** – Displays the downlink Receive Signal Strength Indicator for the selected time period.
- **Median Rx Rate** – Displays the average number of received data packets in Megabits per second for the selected time period.
- **Last Rx Rate** – Displays the last 1 or 15 minutes of received data, depending on the configuration of the Integration Time settings, in Megabits per second for the selected time period.
- **Maximum Rx Rate** – Displays the maximum received data rate in Megabits per second, for the selected time period.
- **Minimum Rx Rate** – Displays the minimum received data rate in Megabits per second, for the selected time period.
- **UL SNR (dB)** – Displays the median level of Signal-to-Noise Ratio received by the base station from the Extreme CPE, for the selected time period.
- **UL RSSI (dBm)** – Displays the median level of Receive Signal Strength Indication that the base station detects from the Extreme CPE, for the selected time period.
- **Median Tx Rate** – Displays the average number of data packets transmitted in Megabits per second, for the selected time period.
- **Last Tx Rate** – Displays the last 1 or 15 minutes of data packets transmitted in Megabits per second. The frequency for this parameter can be set on the Integration Time page.
- **Maximum Tx Rate** – Displays the maximum rate of data transfer for the selected time period.
- **Minimum Tx Rate** – Displays the minimum rate of data transfer for the selected time period.
- **Apply** – Applies the Ethernet Historical Counter setting and saves it.

## 10.5 Ethernet Historical

The Link Quality Historical Counters page allows you to set a start/stop time and date for monitoring Ethernet link quality statistics.

| Ethernet Historical Counters |                             |
|------------------------------|-----------------------------|
| Start time & date:           | 1970 / 01 / 01 00 : 00 : 00 |
| Stop time & date:            | 1970 / 02 / 01 01 : 00 : 00 |
| Rx LAN Port Bit Rate         | 1067.528931                 |
| Rx LAN Packet Rate           | 0.998000                    |
| Tx LAN Port Bit Rate         | 2631.861328                 |
| Tx LAN Packet Rate           | 1.059667                    |
| Rx LAN Port Total Bytes      | 1200970                     |
| Rx LAN Port Total Packets    | 8982                        |
| Tx LAN Port Total Bytes      | 2960844                     |
| Tx LAN Port Total Packets    | 9537                        |
| Rx WAN Port Bit Rate         | 0.000000                    |
| Rx WAN Packet Rate           | 0.000000                    |
| Tx WAN Port Bit Rate         | 0.000000                    |
| Tx WAN Packet Rate           | 0.000000                    |
| Rx WAN Port Total Bytes      | 0                           |
| Rx WAN Port Total Packets    | 0                           |
| Tx WAN Port Total Bytes      | 0                           |
| Tx WAN Port Total Packets    | 0                           |

**Figure 10-41: Performance Monitor - Ethernet Historical**

**ETHERNET HISTORICAL COUNTERS** – The Ethernet Historical Counters page allows the user to modify the time over which to monitor the Ethernet link and to display Ethernet receive/transmit link statistics.

- **Start Time & Date** – Allows the user to enter the year, month, day, hour, minute and second on which to start monitoring the Ethernet link.
- **Stop time & date** – Allows the user to enter the year, month, day, hour, minute and second on which to stop monitoring the Ethernet link.
- **Rx LAN Port Bit Rate** – Displays the received bit rate of the Ethernet LAN port, for the selected time period.

- **Rx LAN Port Packet Rate** – Displays the received packet rate of the Ethernet LAN port, for the selected time period.
- **Tx LAN Port Bit Rate** – Displays the transmitted bit rate of the Ethernet LAN port, for the selected time period.
- **Tx LAN Port Packet Rate** – Displays the transmitted packet rate of the Ethernet LAN port, for the selected time period.
- **Rx LAN Port Total Bytes** – Displays the total bytes received by the Ethernet LAN port, for the selected time period.
- **Rx LAN Port Total Packets** – Displays the total number of packets received by the Ethernet LAN port, for the selected time period.
- **Tx LAN Port Total Bytes** – Displays the total bytes transmitted by the Ethernet LAN port, for the selected time period.
- **Tx LAN Port Total Packets** – Displays the total number of packets transmitted by the Ethernet LAN port, for the selected time period.
- **Rx WAN Port Bit Rate** – Displays the received bit rate of the WiMAX WAN port, for the selected time period.
- **Rx WAN Packet Rate** – Displays the received packet rate of the WiMAX WAN port, for the selected time period.
- **Tx WAN Port Bit Rate** – Displays the transmitted bit rate of the WiMAX WAN port, for the selected time period.
- **Tx WAN Packet Rate** – Displays the transmitted packet rate of the WiMAX WAN port, for the selected time period.
- **Rx WAN Port Total Bytes** – Displays the total number of bytes received by the WiMAX WAN port, for the selected time period.
- **Rx WAN Port Total Packets** – Displays the total number of packets received by the WiMAX WAN port, for the selected time period.
- **Tx WAN Port Total Bytes** – Displays the total number of bytes transmitted by the WiMAX WAN port, for the selected time period.

- **Tx WAN Port Total Packets** – Displays the total number of packets transmitted by the WiMAX WAN port, for the selected time period.

## 10.6 Integration Time

The Integration Time page allows you to set the frequency with which the Extreme CPE will monitor traffic statistics on both the WiMAX link and Ethernet link.



**Figure 10-42: Performance Monitor - Integration Time**

**LINK QUALITY HISTORICAL** – The Link Quality Historical page allows the user to define a time period for monitoring the WiMAX WAN port link.

- **1 Min Counters** – Sets the counter to a duration of one minute.
- **15 Min Counters** – Sets the counter to a duration of fifteen minutes.
- **Apply** – Applies the chosen setting.

**ETHERNET HISTORICAL** – The Ethernet Historical page allows the user to define a time period for monitoring the Ethernet LAN port link.

- **1 Min Counters** – Sets the counter to a duration of one minute.
- **15 Min Counters** – Sets the counter to a duration of fifteen minutes.
- **Apply** – Applies the chosen setting.



## 10.7 Spectrum Analyzer

The Spectrum Analyzer page allows the Extreme CPE to provide off line Spectrum analyzing for walk test / drive test site surveying. The Spectrum analyzer runs an off line frequency scanning from the WEB interface.

A spectrum analysis identifies, classifies, and finds sources of RF interferences that impact the performance of WiMAX networks.

---

### Spectrum Analyzer

---

**Figure 10-43: Performance Monitor - Spectrum Analyzer**



---

## Chapter 11 - Service

### In This Chapter:

- “Introduction” on page 108
- “Show Service” on page 109
- “Service Parameters” on page 110

## 11.1 Introduction

The Service page allows configuration of VLANs and DSCP parameters.

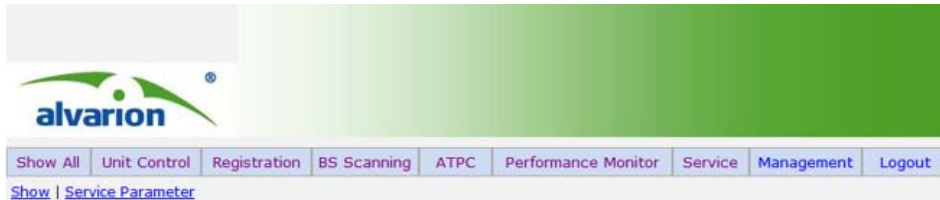

**Figure 11-44: Service Menu**

## 11.2 Show Service

The Show All parameters, Service Parameters page displays the service line count and the operation mode.

**Show All parameters, Service Parameters**

---

|                    |      |
|--------------------|------|
| Service Line Count | 8    |
| Operation Mode     | IPCS |

**Figure 11-45: Service - Show Service Parameters**

## 11.3 Service Parameters

The Ethernet On-Line Counters page displays RX and Tx levels for the Ethernet connection.

**Service Parameters**

---

|                 |  |
|-----------------|--|
| Operation mode  | <input checked="" type="radio"/> IP CS <input type="radio"/> Ethernet CS |
| Service Line ID | 1 ▾  |
| VLAN ID         | <input type="text" value="7"/>   |
| VLAN Priority   | <input type="text" value="0"/>   |
| DSCP Start      | <input type="text" value="0"/>   |
| DSCP Stop       | <input type="text" value="0"/>   |
| DSCP Marking    | <input type="radio"/> Disabled <input checked="" type="radio"/> Enabled  |

|                          | Service ID | VLAN ID Configured | VLAN Priority Configured | DSCP Configured | DSCP Marking |
|--------------------------|------------|--------------------|--------------------------|-----------------|--------------|
| <input type="checkbox"/> | 1          | 7                  | 0                        | 0-0             | Enable       |
| <input type="checkbox"/> | 2          | 6                  | 1                        | 9-10            | Disable      |
| <input type="checkbox"/> | 3          | 6                  | 1                        | 11-12           | Disable      |
| <input type="checkbox"/> | 4          | 8                  | 4                        | 62-62           | Disable      |
| <input type="checkbox"/> | 5          | Untagged           | Untagged                 | 11-11           | Disable      |
| <input type="checkbox"/> | 6          | Untagged           | Untagged                 | 13-14           | Disable      |
| <input type="checkbox"/> | 7          | Untagged           | Untagged                 | 15-16           | Disable      |
| <input type="checkbox"/> | 8          | Untagged           | Untagged                 | 0-0             | Enable       |

**Figure 11-46: Service - Service Parameters**

---

## Chapter 12 - Management

### In This Chapter:

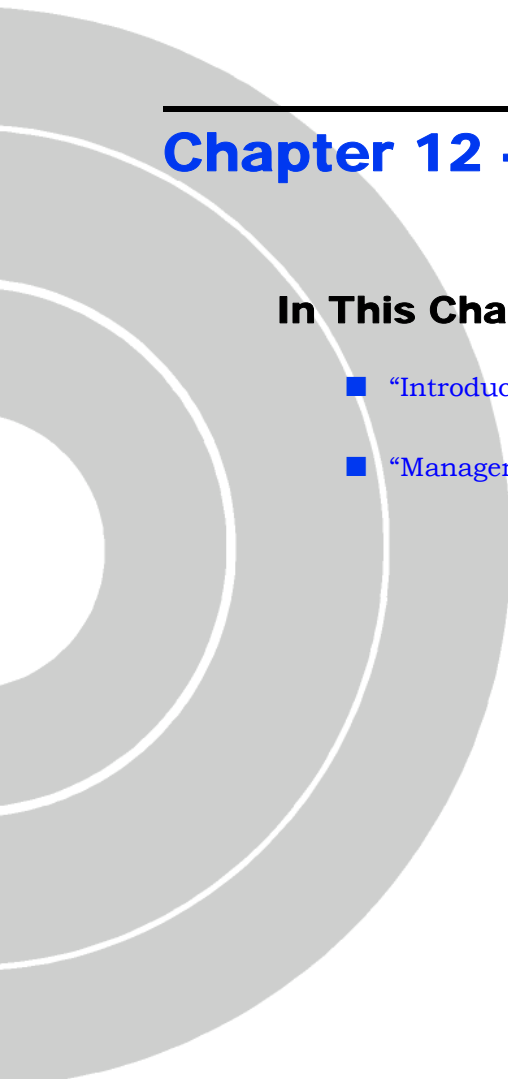
- [“Introduction” on page 112](#)
  - [“Management Parameters” on page 113](#)
- 

## 12.1 Introduction

The Management page displays system management statistics.



**Figure 12-47: Management Menu**



## 12.2 Management Parameters

The Management Parameters page displays non-configurable DSCP and IP related statistics.

|                                       |               |
|---------------------------------------|---------------|
| Factory Defaults DSCP Classifier      | 6             |
| Actual used DSCP Classifier           | 6             |
| Configured DSCP Classifier            | 6             |
| Management IP address                 | 10.11.12.13   |
| eCPE manager IP address               | 12.13.14.15   |
| eCPE manager server connection status | Not Connected |

**Figure 12-48: Management - Management Parameters**



---

## Chapter 13 - Logout

### In This Chapter:

- [“Logout” on page 116](#)
- 

## 13.1 Logout

The Logout page enables you to log out of the web interface and terminate your session. Logging out is preceded by a prompt to log in again.



Figure 13-49: Logout

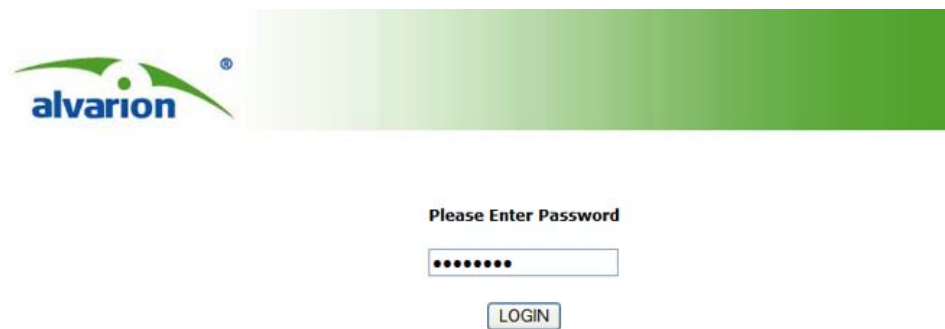

Figure 13-50: Login



# A

---

## Appendix A - Troubleshooting

### In This Chapter:

This appendix provides a lists of things to check in case of problems before contacting local Technical Support.

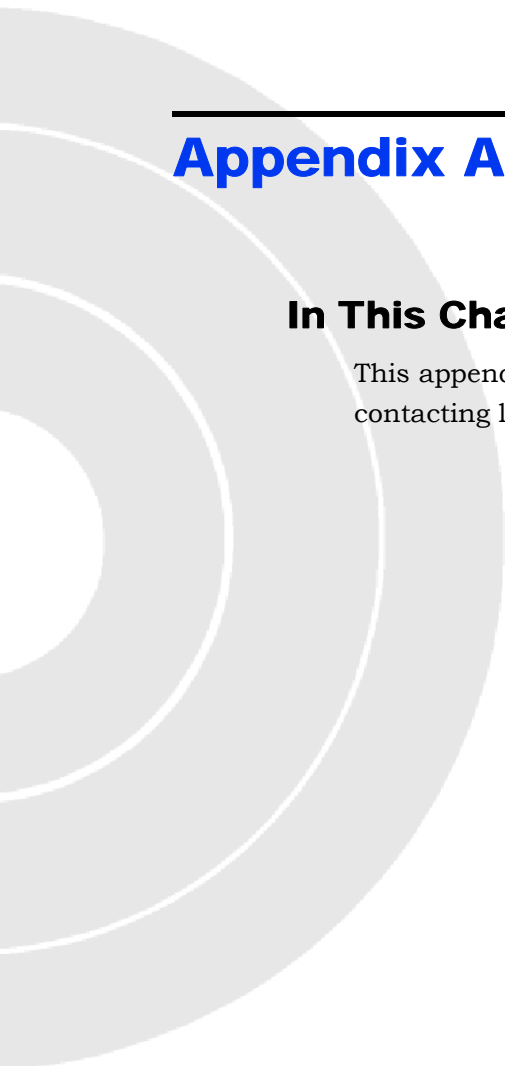

Check the following before you contact local Technical Support.

- 1 If you cannot access the Internet from the PC, check the following:
  - ◇ If you cannot access the Internet, be sure your Windows system is correctly configured for TCP/IP. The IP settings should be set to “obtain an IP address automatically.”
  - ◇ The WAN Type settings for the service provider may not be configured correctly. Use the web interface to check that the WAN settings match those provided by the service provider.
  - ◇ You may be out of the service area of the WiMAX base station. Check with the WiMAX service provider for service coverage information.
  - ◇ If you cannot resolve the problem, check the System Status page of the web interface and contact your WiMAX service provider.
- 2 If the management interface cannot be accessed using a web browser:
  - ◇ Be sure the management station is correctly configured for TCP/IP. The IP settings should be set to “obtain an IP address automatically.”
  - ◇ Try a Ping command from the management station to the unit’s IP address to verify that the entire network path between the two devices is functioning correctly.
  - ◇ Check that the management station has a valid network connection and that the Ethernet port that you are using has not been disabled.
  - ◇ Check the network cabling between the management station and the unit. If the problem is not resolved, try using a different port or a different cable.
- 3 Forgot or Lost the Password
  - ◇ Set the unit to its default configuration by pressing the reset button on the back panel for 5 seconds or more. Then use the default password “admin” to access the management interface.
- 4 If all other recovery measures fail and the unit is still not functioning properly, take either of these steps:
  - ◇ Reset the unit using the web interface, or through a power reset.

**Table A-1: Troubleshooting Chart**

| Ports                 | Description   |
|-----------------------|---|
| ■ POWER LED is Off    | <ul style="list-style-type: none"><li>◇ AC power adapter may be disconnected. Check connections between the unit, the AC power adapter, and the wall outlet.</li><li>◇ The unit has detected a system error. Reboot the unit to try and clear the condition.</li><li>◇ If the condition does not clear, contact your local dealer for assistance.</li></ul>   |
| ■ ETH link LED is Off | <ul style="list-style-type: none"><li>◇ Verify that the unit and attached device are powered on.</li><li>◇ Be sure the cable is plugged into both the unit and corresponding device.</li><li>◇ Verify that the proper cable type is used and its length does not exceed specified limits.</li><li>◇ Check the cable connections for possible defects. Replace the defective cable if necessary.</li></ul> |







# B

---

## Appendix B - GNU License

### In This Chapter:

This appendix provides summary of the terms and conditions of use of the GNU license that applies to the software on the Extreme CPE.

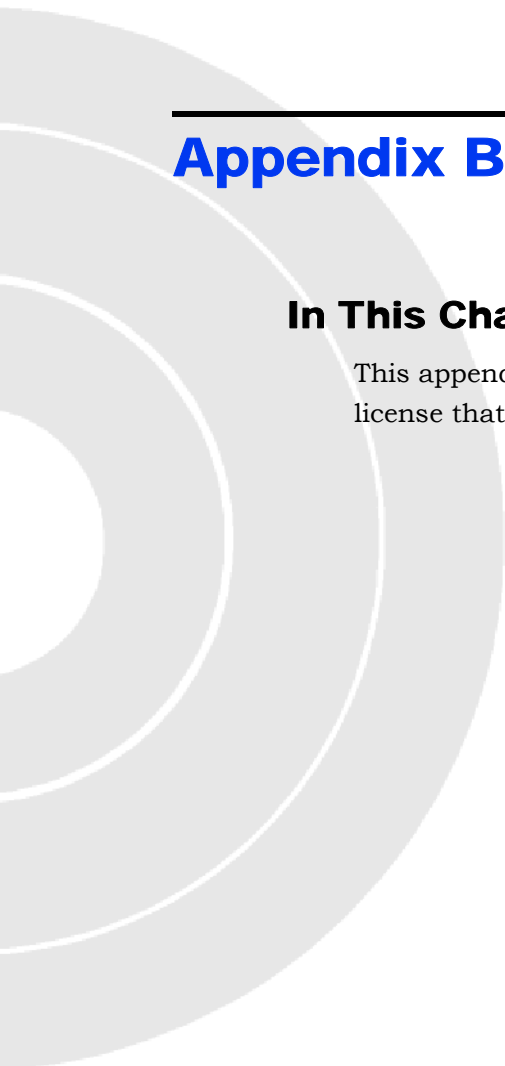

This product includes copyrighted third-party software subject to the terms of the GNU General Public License (GPL), GNU Lesser General Public License (LGPL), or other related free software licences. The GPL code used in this product is distributed WITHOUT ANY WARRANTY and is subject to the copyrights of one or more authors. For details, refer to the section “The GNU General Public License” below, or refer to the applicable licence as included in the source-code archive.

## B.1 The GNU General Public License

GNU GENERAL PUBLIC LICENSE

Version 2, June 1991

Copyright (C) 1989, 1991 Free Software Foundation, Inc.

59 Temple Place, Suite 330, Boston, MA 02111-1307 USA

Everyone is permitted to copy and distribute verbatim copies of this license document, but changing it is not allowed.

## B.1.1 Preamble

The licenses for most software are designed to take away your freedom to share and change it. By contrast, the GNU General Public License is intended to guarantee your freedom to share and change free software--to make sure the software is free for all its users. This General Public License applies to most of the Free Software Foundation's software and to any other program whose authors commit to using it. (Some other Free Software Foundation software is covered by the GNU Library General Public License instead.) You can apply it to your programs, too.

When we speak of free software, we are referring to freedom, not price. Our General Public Licenses are designed to make sure that you have the freedom to distribute copies of free software (and charge for this service if you wish), that you receive source code or can get it if you want it, that you can change the software or use pieces of it in new free programs; and that you know you can do these things.

To protect your rights, we need to make restrictions that forbid anyone to deny you these rights or to ask you to surrender the rights. These restrictions translate to certain responsibilities for you if you distribute copies of the software, or if you modify it.

For example, if you distribute copies of such a program, whether gratis or for a fee, you must give the recipients all the rights that you have. You must make sure that they, too, receive or can get the source code. And you must show them these terms so they know their rights.

We protect your rights with two steps: (1) copyright the software, and (2) offer you this license which gives you legal permission to copy, distribute and/or modify the software.

Also, for each author's protection and ours, we want to make certain that everyone understands that there is no warranty for this free software. If the software is modified by someone else and passed on, we want its recipients to know that what they have is not the original, so that any problems introduced by others will not reflect on the original authors' reputations.

Finally, any free program is threatened constantly by software patents. We wish to avoid the danger that redistributors of a free program will individually obtain patent licenses, in effect making the program proprietary. To prevent this, we have made it clear that any patent must be licensed for everyone's free use or not licensed at all.

The precise terms and conditions for copying, distribution and modification follow.

## B.1.2 GNU GENERAL PUBLIC LICENSE TERMS AND CONDITIONS FOR COPYING, DISTRIBUTION AND MODIFICATION

This License applies to any program or other work which contains a notice placed by the copyright holder saying it may be distributed under the terms of this General Public License. The "Program", below, refers to any such program or work, and a "work based on the Program" means either the Program or any derivative work under copyright law: that is to say, a work containing the Program or a portion of it, either verbatim or with modifications and/or translated into another language. (Hereinafter, translation is included without limitation in the term "modification".) Each licensee is addressed as "you".

Activities other than copying, distribution and modification are not covered by this License; they are outside its scope. The act of running the Program is not restricted, and the output from the Program is covered only if its contents constitute a work based on the Program (independent of having been made by running the Program). Whether that is true depends on what the Program does.

You may copy and distribute verbatim copies of the Program's source code as you receive it, in any medium, provided that you conspicuously and appropriately publish on each copy an appropriate copyright notice and disclaimer of warranty; keep intact all the notices that refer to this License and to the absence of any warranty; and give any other recipients of the Program a copy of this License along with the Program.

You may charge a fee for the physical act of transferring a copy, and you may at your option offer warranty protection in exchange for a fee.

You may modify your copy or copies of the Program or any portion of it, thus forming a work based on the Program, and copy and distribute such modifications or work under the terms of Section 1 above, provided that you also meet all of these conditions:

You must cause the modified files to carry prominent notices stating that you changed the files and the date of any change.

You must cause any work that you distribute or publish, that in whole or in part contains or is derived from the Program or any part thereof, to be licensed as a whole at no charge to all third parties under the terms of this License.

If the modified program normally reads commands interactively when run, you must cause it, when started running for such interactive use in the most ordinary way, to print or display an announcement including an appropriate copyright notice and a notice that there is no warranty (or else, saying that you provide a warranty) and that users may redistribute the program under these conditions, and telling the user how to view a copy of this License. (Exception: if the Program itself is interactive but does not normally print such an announcement, your work based on the Program is not required to print an announcement.)

These requirements apply to the modified work as a whole. If identifiable sections of that work are not derived from the Program, and can be reasonably considered independent and separate works in themselves, then this License, and its terms, do not apply to those sections when you distribute them as separate works. But when you distribute the same sections as part of a whole which is a work based on the Program, the distribution of the whole must be on the terms of this License, whose permissions for other licensees extend to the entire whole, and thus to each and every part regardless of who wrote it.

Thus, it is not the intent of this section to claim rights or contest your rights to work written entirely by you; rather, the intent is to exercise the right to control the distribution of derivative or collective works based on the Program.

In addition, mere aggregation of another work not based on the Program with the Program (or with a work based on the Program) on a volume of a storage or distribution medium does not bring the other work under the scope of this License.

You may copy and distribute the Program (or a work based on it, under Section 2) in object code or executable form under the terms of Sections 1 and 2 above provided that you also do one of the following:

Accompany it with the complete corresponding machine-readable source code, which must be distributed under the terms of Sections 1 and 2 above on a medium customarily used for software interchange; or,

Accompany it with a written offer, valid for at least three years, to give any third party, for a charge no more than your cost of physically performing source distribution, a complete machine-readable copy of the corresponding source code, to be distributed under the terms of Sections 1 and 2 above on a medium customarily used for software interchange; or,

Accompany it with the information you received as to the offer to distribute corresponding source code. (This alternative is allowed only for noncommercial distribution and only if you received the program in object code or executable form with such an offer, in accord with Subsection b above.)

The source code for a work means the preferred form of the work for making modifications to it. For an executable work, complete source code means all the source code for all modules it contains, plus any associated interface definition files, plus the scripts used to control compilation and installation of the executable. However, as a special exception, the source code distributed need not include anything that is normally distributed (in either source or binary form) with the major components (compiler, kernel, and so on) of the operating system on which the executable runs, unless that component itself accompanies the executable.

If distribution of executable or object code is made by offering access to copy from a designated place, then offering equivalent access to copy the source code from the same place counts as distribution of the source code, even though third parties are not compelled to copy the source along with the object code.

You may not copy, modify, sublicense, or distribute the Program except as expressly provided under this License. Any attempt otherwise to copy, modify, sublicense or distribute the Program is void, and will automatically terminate your rights under this License. However, parties who have received copies, or rights, from you under this License will not have their licenses terminated so long as such parties remain in full compliance.

You are not required to accept this License, since you have not signed it. However, nothing else grants you permission to modify or distribute the Program or its derivative works. These actions are prohibited by law if you do not accept this License. Therefore, by modifying or distributing the Program (or any work based on the Program), you indicate your acceptance of this License to do so, and all its terms and conditions for copying, distributing or modifying the Program or works based on it.

Each time you redistribute the Program (or any work based on the Program), the recipient automatically receives a license from the original licensor to copy, distribute or modify the Program subject to these terms and conditions. You may not impose any further restrictions on the recipients' exercise of the rights granted herein. You are not responsible for enforcing compliance by third parties to this License.

If, as a consequence of a court judgment or allegation of patent infringement or for any other reason (not limited to patent issues), conditions are imposed on you (whether by court order, agreement or otherwise) that contradict the conditions of this License, they do not excuse you from the conditions of this License. If you cannot distribute so as to satisfy simultaneously your obligations under this License and any other pertinent obligations, then as a consequence you may not distribute the Program at all. For example, if a patent license would not permit

royalty-free redistribution of the Program by all those who receive copies directly or indirectly through you, then the only way you could satisfy both it and this License would be to refrain entirely from distribution of the Program.

If any portion of this section is held invalid or unenforceable under any particular circumstance, the balance of the section is intended to apply and the section as a whole is intended to apply in other circumstances.

It is not the purpose of this section to induce you to infringe any patents or other property right claims or to contest validity of any such claims; this section has the sole purpose of protecting the integrity of the free software distribution system, which is implemented by public license practices. Many people have made generous contributions to the wide range of software distributed through that system in reliance on consistent application of that system; it is up to the author/donor to decide if he or she is willing to distribute software through any other system and a licensee cannot impose that choice.

This section is intended to make thoroughly clear what is believed to be a consequence of the rest of this License.

If the distribution and/or use of the Program is restricted in certain countries either by patents or by copyrighted interfaces, the original copyright holder who places the Program under this License may add an explicit geographical distribution limitation excluding those countries, so that distribution is permitted only in or among countries not thus excluded. In such case, this License incorporates the limitation as if written in the body of this License.

The Free Software Foundation may publish revised and/or new versions of the General Public License from time to time. Such new versions will be similar in spirit to the present version, but may differ in detail to address new problems or concerns.

Each version is given a distinguishing version number. If the Program specifies a version number of this License which applies to it and "any later version", you have the option of following the terms and conditions either of that version or of any later version published by the Free Software Foundation. If the Program does not specify a version number of this License, you may choose any version ever published by the Free Software Foundation.

If you wish to incorporate parts of the Program into other free programs whose distribution conditions are different, write to the author to ask for permission. For software which is copyrighted by the Free Software Foundation, write to the Free Software Foundation; we sometimes make exceptions for this. Our decision will be guided by the two goals of preserving the free status of all derivatives of our free software and of promoting the sharing and reuse of software generally.

#### NO WARRANTY

BECAUSE THE PROGRAM IS LICENSED FREE OF CHARGE, THERE IS NO WARRANTY FOR THE PROGRAM, TO THE EXTENT PERMITTED BY APPLICABLE LAW. EXCEPT WHEN OTHERWISE STATED IN WRITING THE COPYRIGHT HOLDERS AND/OR OTHER PARTIES PROVIDE THE PROGRAM "AS IS" WITHOUT WARRANTY OF ANY KIND, EITHER EXPRESSED OR IMPLIED, INCLUDING, BUT NOT LIMITED TO, THE IMPLIED WARRANTIES OF MERCHANTABILITY AND FITNESS FOR A PARTICULAR PURPOSE. THE ENTIRE RISK AS TO THE QUALITY AND PERFORMANCE OF THE PROGRAM IS WITH YOU. SHOULD THE PROGRAM PROVE DEFECTIVE, YOU ASSUME THE COST OF ALL NECESSARY SERVICING, REPAIR OR CORRECTION.

IN NO EVENT UNLESS REQUIRED BY APPLICABLE LAW OR AGREED TO IN WRITING WILL ANY COPYRIGHT HOLDER, OR ANY OTHER PARTY WHO MAY MODIFY AND/OR REDISTRIBUTE THE PROGRAM AS PERMITTED ABOVE, BE LIABLE TO YOU FOR DAMAGES, INCLUDING ANY GENERAL, SPECIAL, INCIDENTAL OR CONSEQUENTIAL DAMAGES ARISING OUT OF THE USE OR INABILITY TO USE THE PROGRAM (INCLUDING BUT NOT LIMITED TO LOSS OF DATA OR DATA BEING RENDERED INACCURATE OR LOSSES SUSTAINED BY YOU OR THIRD PARTIES OR A FAILURE OF THE PROGRAM TO OPERATE WITH ANY OTHER PROGRAMS), EVEN IF SUCH HOLDER OR OTHER PARTY HAS BEEN ADVISED OF THE POSSIBILITY OF SUCH DAMAGES.

#### **END OF TERMS AND CONDITIONS**





# Glossary



## **100BASE-TX**

IEEE 802.3u specification for 100 Mbps Fast Ethernet over two pairs of Category 5 or better UTP cable.

## **10BASE-T**

IEEE 802.3 specification for 10 Mbps Ethernet over two pairs of Category 3 or better UTP cable

## **Advanced Encryption Standard (AES)**

An strong encryption algorithm that implements symmetric key cryptography.

## **Authentication**

The process to verify the identity of a client requesting network access. IEEE 802.11 specifies two forms of authentication: open system and shared key.

## **Auto-negotiation**

Signalling method allowing each node to select its optimum operational mode (speed and duplex mode) based on the capabilities of the node to which it is connected.

## **Base Station**

A WIMAX service provider's equipment that is installed at a fixed location to provide network connectivity for subscriber stations within a defined service area.

## **Broadcast Key**

Broadcast keys are sent to stations using 802.1X dynamic keying. Dynamic broadcast key rotation is often used to allow the access point to generate a random group key and periodically update all key-management capable wireless clients.

## **Customer Premise Equipment (CPE)**

Customer Premise Equipment: Communications equipment that resides on the customer's premises.

## **Domain Name System (DNS)**

A system used for translating host names for network nodes into IP addresses.

## **Dynamic Host Control Protocol (DHCP)**

Dynamic Host Configuration Protocol: Provides a framework for passing configuration information to hosts on a TCP/IP network. DHCP is based on the Bootstrap Protocol (BOOTP), adding the capability of automatic allocation of reusable network addresses and additional configuration options.

## **Ethernet**

A popular local area data communications network, which accepts transmission from computers and terminals.

|   |  |
|---|--|
| <b>Encryption</b>                               | Data passing between the SU-A-EZ and clients can use encryption to protect from interception and eavesdropping.  |
| <b>Extended Service Set (ESS)</b>               | Extended Service Set: More than one wireless cell can be configured with the same Service Set Identifier to allow mobile users can roam between different cells with the Extended Service Set.   |
| <b>Extensible Authentication Protocol (EAP)</b> | An authentication protocol used to authenticate network clients. EAP is combined with IEEE 802.1X port authentication and a RADIUS authentication server to provide “mutual authentication” between a client, the access point, and the a RADIUS server  |
| <b>File Transfer Protocol (FTP)</b>             | File Transfer Protocol: A TCP/IP protocol used for file transfer.  |
| <b>Hypertext Transfer Protocol (HTTP)</b>       | Hypertext Transfer Protocol: HTTP is a standard used to transmit and receive all data over the World Wide Web.   |
| <b>IEEE 802.16e</b>                             | A standard that provides mobile broadband wireless access using Scalable Orthogonal Frequency Division Multiple Access (SOFDMA).   |
| <b>Local Area Network (LAN)</b>                 | Local Area Network: A group of interconnected computer and support devices.  |
| <b>MAC</b>                                      | Media Access Control: The lower of the two sub-layers of the data link layer defined by the IEEE. The MAC sub-layer handles access to shared media, such as whether token passing or contention will be used.  |
| <b>MAC Address</b>                              | Standardized data link layer address that is required for every port or device that connects to a LAN. Other devices in the network use these addresses to locate specific ports in the network and to create and update routing tables and data structures. MAC addresses are 6bytes long and are controlled by the IEEE. |
| <b>Network Time Protocol (NTP)</b>              | NTP provides the mechanisms to synchronize time across the network. The time servers operate in a hierarchical-master-slave configuration in order to synchronize local clocks within the subnet and to national time standards via wire or radio.   |

---

|  |  |
|--|--|
| <b>Orthogonal Frequency Division Multiplexing (OFDM)</b> | Orthogonal Frequency Division Multiplexing: OFDM allows multiple users to transmit in an allocated band by dividing the bandwidth into many narrow bandwidth carriers.   |
| <b>Power Over Ethernet (PoE)</b>                         | Power over Ethernet: A specification for providing both power and data to low-power network devices using a single Category 5 Ethernet cable. PoE provides greater flexibility in the locating of Wi <sup>2</sup> s and network devices, and significantly decreased installation costs. |
| <b>RTS Threshold</b>                                     | Transmitters contending for the medium may not be aware of each other. RTS/CTS mechanism can solve this “Hidden Node Problem.” If the packet size is smaller than the preset RTS Threshold size, the RTS/CTS mechanism will NOT be enabled.  |
| <b>Service Set Identifier (SSID)</b>                     | An identifier that is attached to packets sent over the wireless LAN and functions as a password for joining a particular radio cell; i.e., Basic Service Set (BSS).   |
| <b>Session Key</b>                                       | Session keys are unique to each client, and are used to authenticate a client connection, and correlate traffic passing between a specific client and the AU-EZ.   |
| <b>Shared Key</b>  | A shared key can be used to authenticate each client attached to a wireless network. Shared Key authentication must be used along with the 802.11 Wireless Equivalent Privacy algorithm.   |
| <b>Simple Network Management Protocol (SNMP)</b>         | Simple Network Management Protocol: The application protocol in the Internet suite of protocols which offers network management services.  |
| <b>Simple Network Time Protocol (SNTP)</b>               | SNTP allows a device to set its internal clock based on periodic updates from a Network Time Protocol (NTP) server. Updates can be requested from a specific NTP server, or can be received via broadcasts sent by NTP servers.  |
| <b>Subscriber Station</b>                                | A general term for a customer’s WIMAX terminal equipment that provides connectivity with a base station.   |
| <b>Subscriber Unit Alignment Unit (SAU)</b>              | An optional device that provides additional assistance in aligning the ODU antenna.  |
| <b>Trivial File Transfer Protocol (TFTP)</b>             | Trivial File Transfer Protocol: A TCP/IP protocol commonly used for software downloads.  |
| <b>UTP</b>   | Unshielded twisted-pair cable.   |

**Wired Equivalent Privacy  
(WEP)**

Wired Equivalent Privacy: WEP is based on the use of security keys and the popular RC4 encryption algorithm. Wireless devices without a valid WEP key will be excluded from network traffic.

## Numerics

10/100BASE-TX pin assignments, 30, 36

## A

aligning the WiMAX antenna, 41

antenna alignment, WiMAX, 40

## B

BreezeMAX approved cable suppliers, 38

BreezeMAX Pro range, 2

## C

cable connections, ODU, 28

configuration and management, 6

configuration, initial setup, 43

## E

electrical, 7

environment, 7

Ethernet cable, IDU to ODU, 28

## G

GNU, 121

GNU license, 121, 122

## I

IDU hardware description, 19

IDU, 10BASE-T/100BASE-TX LANports, 20

IDU, ODU port, 20

IDU, optional backup battery charger, 21

IDU, power socket, 21

initial setup, 43

installation requirements, 12

installation steps, 22

installation steps, IDU installation, 26

installation steps, IDU location, 26

installation steps, mount the ODU, 23

installation steps, ODU, 23

installation steps, ODU location, 23

## M

MDI, RJ-45 pin configuration, 19

mechanical, 6

## O

ODU, Ethernet port, 13

ODU, ground screw, 15

ODU, hardware description, 13

ODU, optional SAU, 17

ODU, optional tilt-mount bracket, 16

ODU, pole-mounting kit, 16

ODU, SAU port, 13

ODU, weatherproof covers, 14

ODU, WiMAX antenna, 13

## P

packing list, 12

preparing Ethernet cables, 36

PoE, 20, 27

Power over Ethernet *See* PoE

## R

RSSI BNC, 20, 75

## S

specifications, 4

configuration and management, 6

electrical, 7

environmental, 7

mechanical, 6

radio, 4

sensitivity, 5

standards compliance, 8

specifications, VoIP, 5

specifications, WiMAX radio, 4

standards compliance, 8

## T

troubleshooting, 117, 121

**W**

web menu, 48