

# ***BreezeACCESS MMDS***

***Indoor Subscriber Units***

***SU-I-D-MMDS Series***

# **Installation Manual**

July, 2000

Cat. No. 213099

© 1999 by BreezeCOM Ltd. All rights reserved.

No part of this publication may be reproduced in any material form without the written permission of the copyright owner.

## **Trade Names**

BreezeACCESS, BreezeNET, BreezeLINK, BreezeVIEW and WIX are trade names of BreezeCOM Ltd. Other brand and product names are registered trademarks or trademarks of their respective companies.

## **Statement of Conditions**

The information contained in this manual is subject to change without notice. BreezeCOM shall not be liable for errors contained herein or for incidental or consequential damages in connection with the furnishing, performance, or use of this manual or equipment supplied with it.

## **Warranty**

In the following warranty text, “the Company” shall mean:

- BreezeCOM Ltd., for products located outside the USA.
- BreezeCOM Inc., for products located in the USA.

This BreezeACCESS product is warranted against defects in material and workmanship for a period of one year from date of purchase. During this warranty period the Company will, at its option, either repair or replace products that prove to be defective.

For warranty service or repair, the product must be returned to a service facility designated by the Company. Authorization to return products must be obtained prior to shipment. The buyer shall pay all shipping charges to the Company and the Company shall pay shipping charges to return the product to the buyer within the USA.

The Company warrants that the firmware designed by it for use with the unit will execute its programming instructions when properly installed on the unit. The Company does not warrant that the operation of the unit or firmware will be uninterrupted or error-free.

## **Limitation of Warranty**

The foregoing warranty shall not apply to defects resulting from improper or inadequate maintenance by the buyer, buyer supplied interfacing, unauthorized modification or misuse, operation outside of the environmental specifications for the product, or improper site preparation or maintenance. No other warranty is expressed or implied. The company specifically disclaims the implied warranties of merchantability and fitness for any particular purpose.

BreezeCOM shall not be liable to any person for any special or indirect damages, including, but not limited to, loss of profits or revenues, loss of use or damage to any associated equipment, cost of capital, cost of substitute products, facilities or services, downtime costs or claims resulting from any cause whatsoever arising from or in any way connected with the manufacture, sale, handling, service, repair, maintenance or use of the products. In no event shall the company's liability exceed the purchase price denoted on the invoice.

## **Electronic Emission Notice**

This device complies with Part 15 of the FCC rules. Operation is subject to the following two conditions:

1. This device may not cause harmful interference.
2. This device must accept any interference received, including interference that may cause undesired operation.

## **FCC Radio Frequency Interference Statement**

This equipment has been tested and found to comply with the limits for a class A digital device, pursuant to Part 15 of the FCC rules. These limits are designed to provide reasonable protection against harmful interference when the equipment is operated in a commercial environment. This equipment generates, uses, and can radiate radio frequency energy and, if not installed and used in accordance with the instruction manual, may cause harmful interference to radio communications. Operation of this equipment in a residential area is likely to cause harmful interference in which case the user will be required to correct the interference at his own expense.

## **Information to User**

Any changes or modifications of equipment not expressly approved by the manufacturer could void the user's authority to operate the equipment.

## **Safety Considerations**

For the following safety considerations, "Instrument" means the **BreezeACCESS Subscriber or Access** unit components and their cables.

## **Caution**

To avoid shock, do not perform any servicing unless you are qualified to do so.

## **Grounding**

Before connecting the instrument to the power line, verify that a suitable power cord is being used (the protective earth terminal of this instrument must be connected to the protective conductor of the power cord). The mains plug shall only be inserted in a socket outlet provided with a protective earth contact. If an extension cord (power cable) is used make sure it has a protective conductor (grounding).

## **Line Voltage**

Before connecting this instrument to the power line, make sure that the voltage of the power source matches the requirements of the instrument: 100-250 VAC, 50-60 Hz.

## **Radio**

The instrument transmits radio energy during normal operation. To avoid possible harmful exposure to this energy, do not stand or work for extended periods of time in front of its antenna. The long-term characteristics or the possible physiological effects of Radio Frequency Electromagnetic fields have not been yet fully investigated.

## **Antenna Installation and Grounding**

Be sure that the outdoor antennas and the supporting structure are properly installed to eliminate any physical hazard to either people or property. Verify that the antenna mast is grounded so as to provide protection against voltage surges and static charges. Make sure that the installation of the antenna and cable is performed in accordance with all relevant national and local building and safety codes.

# Table of Contents

---

<b>1. INTRODUCTION .....</b>	<b>1</b>
<b>2. BASIC INSTALLATION .....</b>	<b>2</b>
2.1 Packing List .....	2
2.2 Other Required Items .....	2
2.3 Installation Overview .....	3
2.4 Installation Guidelines .....	4
2.4.1 Location of the Unit and Antenna(s) .....	4
2.4.2 Location of the Antenna(s) .....	4
2.4.3 Antenna Diversity .....	5
2.4.4 Antenna Polarization.....	5
2.4.5 Antenna Seal .....	5
2.4.6 Lightning Protection .....	6
2.5 Wall Mounting the Unit .....	7
2.6 Connecting Antenna(s) to the Units.....	8
2.7 Connecting the Unit to the Power Supply and to the CPE.....	9
<b>3. CONFIGURING SYSTEM PARAMETERS.....</b>	<b>10</b>
3.1 Getting Started with the Local Terminal.....	10
3.2 Configuration Parameters .....	12
3.3 Reset Unit.....	14
<b>4. ALIGNING THE ANTENNA .....</b>	<b>15</b>
4.1 Aligning the Antenna Using the LEDs .....	15
4.2 Aligning the Antenna Using the Site Survey Menu.....	16
<b>5. MAXIMUM DATA RATE CONFIGURATION.....</b>	<b>17</b>
<b>6. VERIFYING PROPER OPERATION.....</b>	<b>18</b>

6.1 General .....	18
6.2 Verifying Data Connectivity .....	18
<b>7. SPECIFICATIONS .....</b>	<b>19</b>
7.1 Radio .....	19
7.2 Data Communication .....	19
7.3 Configuration and Management.....	20
7.4 Interfaces .....	20
7.5 Electrical .....	20
7.6 Mechanical .....	20
7.7 Environmental .....	20
APPENDIX A. OPTIONAL RF ACCESSORIES.....	22
APPENDIX B. USING TELNET .....	39

## Table of Figures

---

Figure 2-1. Wall Mounting the Unit .....	7
Figure 2-2. Wall Mounting Plate .....	8
Figure 2-3. Tightening the Cable(s) to the Connector(s) .....	9
Figure 3-1. Main Menu .....	11
Figure 3-2. Basic Configuration Menu .....	13
Table 1. SU-I LEDs .....	18
Figure A-1. TPA 24 Installation .....	23
Figure A-2. LNA 10 Connections Diagram .....	26
Figure A-3. RFS-122 Connection Diagram .....	28
Figure A-4. AL-1 Connection Block Diagram .....	30
Figure A-5. AMP 2440 Functional Block Diagram.....	32
Figure A-6. AMP 2440 Installation and Mounting.....	34
Figure A-7. AMP 2440 Installation Details .....	36





# 1. INTRODUCTION

This manual describes installation guidelines for BreezeACCESS-MMDS SU-I Subscriber Units.

The BreezeACCESS IP Broadband Wireless Local Loop (WLL) system allows access service providers to provide high-speed IP connectivity services to their subscribers. To support IP-based services effectively BreezeACCESS systems employ wireless packet data switching technology.

The BreezeACCESS 2.5 line of products uses Frequency Hopping Spread Spectrum radios that operate in Time Duplex Division (TDD) mode in the 2.500GHz – 2.686GHz frequency range.

The SU-I-D-MMDS line of Subscriber Units comprises compact units that are designed for indoor installation. Antennas can be installed either indoors or outdoors, depending on the specific site conditions. The SU-I-D-MMDS series include the following products:

- SU-I-1D-MMDS: supports a single Ethernet device
- SU-I-8D-MMDS: supports up to eight Ethernet workstations/PCs
- SU-I-BD-MMDS: supports a LAN (a bridge functionality)

---

**Note:** *The information contained in this manual is applicable to BreezeACCESS MMDS units with software release 2.3.*

---

## **2. BASIC INSTALLATION**

### **2.1 Packing List**

The SU-I units are shipped with the following units and accessories. The exact packing list varies depending on system configuration and ordered equipment.

- SU-I unit
- A 5 VDC universal power supply transformer
- Mounting bracket for wall or ceiling installation
- A torque key for antenna connectors

### **2.2 Other Required Items**

The following items must be available for the installation

- Antenna(s)\*and RF cable(s)\*(according to specific installation requirements)\*
- A PC with terminal emulation program
- A monitor cable\* (supplied with each AU)
- An Ethernet cable (straight)
- Installation tools and materials

---

*Items marked with an asterisk (\*) are available from BreezeCOM.*

---

## 2.3 Installation Overview

Standard installation involves the following steps:

1. Verify that all components of the packing list, described in Section 2.1, are intact and verify availability of the required items listed in Section 2.2.
2. Install the unit and antenna(s) in optimal locations as described in Section 2.4.
3. Connect the antenna(s) to the unit as described in Section 2.6.
4. Connect the power supply to the unit as described in Section 2.7.
5. Connect the Ethernet port to the unit as described in Section 2.7.
6. Configure the basic system parameters as described in Section 3.
7. Align the antenna(s) for optimal connectivity and configure the Maximum Data Rate if applicable, as described in Chapters 4 and 5.
8. Check the functionality of the unit as described in Chapter 6.

### **Antennas for Indoor Applications**

For most indoor applications, the best choice is the standard unit equipped with its screw-on 2dBi antennas. The units are small, easy to install and cover a large area.

In some installations, it is required to install the unit and antenna separately. In such instances, use the omni-6 antenna kit (6dbi omni-directional antenna with 3 meter RG-58 cable). In the USA (FCC regulated) and in non-regulated countries, the omni-6 comes with a shorter antenna cable, extending the coverage area.

The Uni-8.5 is also useful in indoor applications. It is very small and easily wall-mounted, but its radiation pattern is limited (75°).

BreezeCOM recommends that, for indoor applications, you use two antennas per unit to utilize the diversity gain of the system.

## **2.4 Installation Guidelines**

This section describes the installation guidelines and the various considerations that must be taken into account when planning the installation.

### **2.4.1 Location of the Unit and Antenna(s)**

- The unit can be placed on a shelf, or can be attached to the ceiling or a wall using a mounting bracket. The unit should be installed as near to the antenna(s) as possible to minimize loss of RF power in the cable(s).
- Keep the units well away from sources of heat, such as radiators, air-conditioners, etc.

### **2.4.2 Location of the Antenna(s)**

- Any physical object in the path between two units can cause signal attenuation. Common obstructions are buildings and trees. If a unit's antenna is installed indoors, the walls and/or windows between the two sites are physical obstructions. If the antenna is positioned outdoors, any buildings or other physical structure such as trees, mountains or other natural geographic features higher than the antenna and situated in the path between the two sites can constitute obstructions.
- Install indoor antennas as close as possible to a window (or wall if a window is not accessible) facing the required direction. Avoid metal obstacles such as metal window frames or metal film anti-glare windows in the transmission path. Install outdoor antennas high enough to avoid any obstacles, which may block the signal.
- Position the antennas clear of metal furniture and away from moving metal objects such as metal fans or doors.
- For best performance, position the antennas clear of radiation sources that emit in the 2.5 - 2.7 GHz frequency band, such as microwave ovens.

### **2.4.3 Antenna Diversity**

In applications where no multipath propagation is expected, a single antenna is sufficient to ensure good performance levels. However, in cases where multipath propagation exists, BreezeCOM recommends that two antennas be used. This takes advantage of space diversity capabilities. By using two antennas per unit, the system can select the best antenna on a per-packet basis (every several milliseconds).

Multipath propagation is to be expected when there are potential reflectors between the Access Unit and Subscriber Units. These reflectors may be buildings or moving objects such as airplanes and motor vehicles. If this is the case, the radio signal does not travel in a straight line, but is reflected or deflected off of the object, creating multiple propagation paths.

When installing a single antenna, modify the transmit diversity option to either antenna 1 or antenna 2, according to the antenna being used.

### **2.4.4 Antenna Polarization**

Antenna polarization must be the same at either end of the link. In most applications, the preferred orientation is vertical polarization. Above-ground propagation of the signal is better when it is polarized vertically. To verify antenna polarization, refer to the assembly instructions supplied with the antenna set. For screw-on and detached omni antennas, make sure that the antennas are extended upward vertically in relation to the floor to achieve vertical polarization.

### **2.4.5 Antenna Seal**

When using outdoor antennas, you must seal the antenna connectors against rain. Otherwise the antennas are not suitable for use in outdoor installations.

### **2.4.6 Lightning Protection**

Lightning protection is designed to protect people, property and equipment by providing a path to ground for the lightning's energy. The lightning arrestor diverts the strike energy to ground through a deliberate and controlled path instead of allowing it to choose a random path. Lightning protection for a

building is more forgiving than protection of electronic devices. A building can withstand up to 100,000 volts, but electronic equipment may be damaged by just a few volts.

Lightning protection entails connecting an antenna discharge unit (also called an arrester) to each cable as close as possible to the point where it enters the building. It also entails proper grounding of the arrestors and of the antenna mast (if the antenna is connected to one).

The lightning arrester should be installed and grounded at the point where the cable enters the building. The arrester is connected to the unit at one end and to the antenna at the other end.

The professional installer you choose must be knowledgeable about lightning protection. The installer must install the lightning protector in a way that maximizes lightning protection. BreezeCOM offers the following high-quality lightning arrester assembly:

BreezeACCESS AL 1 Lightning Arrester - Part No. 872905 5 ft (1.5m), “N” Male to “N” Female.

---

**Note:** *Detached antennas, whether installed indoors or out, should be installed ONLY by experienced antenna installation professionals who are familiar with local building and safety codes and, wherever applicable, are licensed by the appropriate government regulatory authorities.*

*Failure to do so may void the BreezeACCESS Product Warranty and may expose the end user to legal and financial liabilities. BreezeCOM and its resellers or distributors are not liable for injury, damage or violation of government regulations associated with the installation of detached antennas.*

---

## 2.5 Wall Mounting the Unit

Use the supplied brackets for wall mounting to install the unit on a wall or a ceiling.

1. Turn the unit so the rear panel is facing you.
2. Unscrew the two screws located at the antennas end of the unit (the top screws).
3. Align the Unit Mounting Slots (see Figure 2-2) with the slots you have just unscrewed.
4. Using the longer screws supplied with the wall mounts, screw the wall mount to the unit.
5. Align the Convenience Mounting Slots (see Figure 2-2) with the nails, push the wall mount against the wall and let it slide down until it rests on the nails.

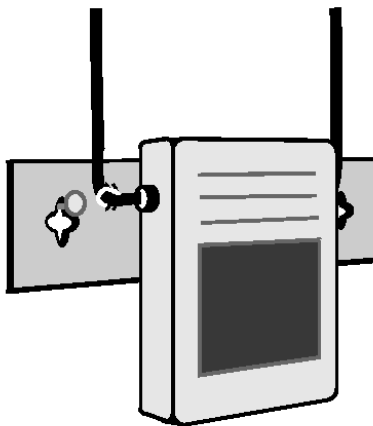

**Figure 2-1. Wall Mounting the Unit**

Special slots have been added to the wall mounts to allow for unobtrusive cable installation. These slots should be used to fasten cables coming out of the unit to the wall mounts, eliminating loose or tangled cable installations.

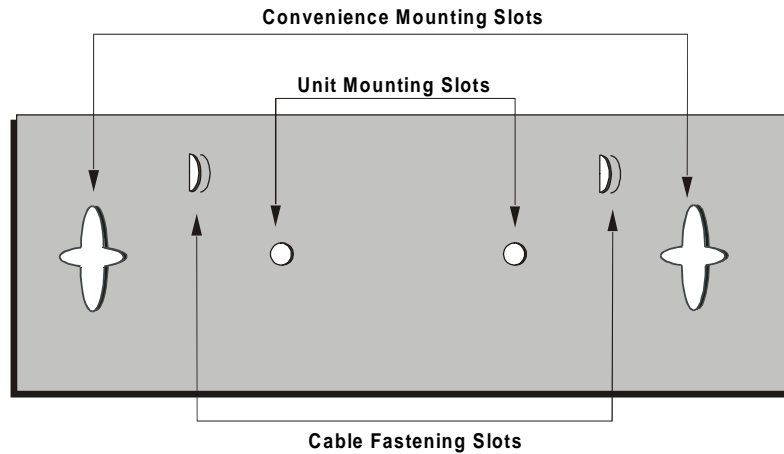

Figure 2-2. Wall Mounting Plate

## 2.6 Connecting Antenna(s) to the Units

For installation convenience, a torque key is included with all BreezeACCESS SU-I units.

---

**WARNING:** *The use of improper tools for tightening antenna connection cables to BreezeACCESS SU-I units may result in damage to the cable connectors.*

---

Use the included torque key to tighten the cable(s) to the connector(s) on the side of the SU-I unit. The key is designed to prevent over tightening of the screws and protects the connectors from damage.

Tighten the cable(s) to the connector(s) using the torque key.



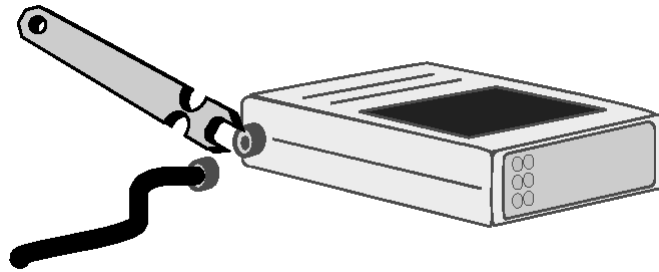

**Figure 2-3. Tightening the Cable(s) to the Connector(s)**

If excessive pressure is applied to tighten the screws, the torque key will break.

---

*Note:* Do not attempt to tighten the screws any further. This may damage the connectors on the BreezeACCESS SU-I unit.

---

## 2.7 Connecting the Unit to the Power Supply and to the CPE

The unit operates on a power input of 5V DC, supplied by the power transformer included with the unit.

1. Plug the output jack of the power transformer into the DC input jack located on the rear panel of the unit.
2. Connect the supplied universal power transformer to a power outlet - 110/220VAC.
3. Use a straight Ethernet 10BaseT cable to connect a PC (SU-I-1D) or a hub (SU-I-8D or SU-I-BD) to the Ethernet port (marked UTP) located on the rear panel of the unit.

## 3. CONFIGURING SYSTEM PARAMETERS

After completing the installation process, as described in the preceding sections of this manual, proceed with configuration of the basic system parameters.

This manual covers the configuration of basic installation parameters. Refer to the Administration Manual for information related to other parameters.

---

*Note:* Optionally, the product can be configured using Telnet over the Ethernet port, after setting IP address. For further information refer to Appendix B.

---

### 3.1 Getting Started with the Local Terminal

1. Connect one end of the Monitor cable to the MON jack on the rear side of the unit. Connect the second end of the cable to the COM port of the terminal. The COM port connector on the Monitor cable is a 9 pin D-type plug.
2. Run a terminal emulation program (e.g., ProComm or Windows HyperTerminal) using the following setup:

<i>Baud rate</i>	9600
<i>Data bits</i>	8
<i>Stop bits</i>	1
<i>Parity</i>	None
<i>Flow Control</i>	Xon/Xoff
<i>Connector</i>	Available Com Port

3. Press **Enter**. The *Select Access Level* menu appears. Select the access level according to your authorized access level. You will be requested to enter your password. After entering the correct password press enter. The main menu appears (refer to Figure 3-1).

```

BreezeACCESS (SU-1D)
Official Release Version - 2.2.6
Release Date: Mon Apr 24 21:52:01 2000
Main Menu
=====
1 - Info Screens
2 - Unit Control
3 - Basic Configuration
4 - Site Survey
5 - Advanced Configuration
BreezeACCESS >>>
    
```

Unit Type

Software Version No.

Unit Name

**Figure 3-1. Main Menu**

The appearance of the displayed *Main Menu* varies in accordance with the access level.

- For users with read only access rights, only the *Info Screens* option is displayed. Users with this access level cannot access the *Unit Control*, *Basic Configuration*, *Site Survey* and *Advanced Configuration* menus.
  - For users with Installer access rights, the first four menu items (*Info Screens*, *Unit Control*, *Basic Configuration* and *Site Survey*) are displayed. Users with this access level cannot access the *Advanced Configuration* menu.
  - For users with Administrator access rights, the full *Main Menu* will be displayed. These users can access all the menu items.
4. Operate the monitor program as follows:
- Type an option number to open/activate the option. You may need to press the Enter key in some cases.

- Press the Esc key to exit a menu or an option.
- You can log-out and exit the monitor program at any time by simultaneously pressing the **Ctrl** and **X** keys.
- Reset the unit after making configuration changes for the new values to take effect.
- You can view the current parameters' configuration by selecting 1 in the Main Menu to Access the Info Screens menu, and then selecting 2 in the Info Screens menu to view the Basic Configuration parameters.

### 3.2 Configuration Parameters

The following system parameters must be configured for each specific installation:

- *ESSID*
- *IP Address*
- *Subnet Mask*
- *Default Gateway Address*
- *Hopping Shift (AU-I only)*
- *Hopping Set (AU-I only)*
- *Transmit Antenna*
- *Maximum Data Rate*

---

**Note:** *You must select Reset Unit in the Unit Control menu for the changes to take effect.*

---

Subscriber Units should be configured after the applicable Access Unit is operational. When configuring Subscriber Units, the first parameter that should be configured is the *ESSID*. Otherwise the unit will not successfully synchronize with the Access Unit and will continuously reset itself, thus interfering with the configuration process.

1. From the *main menu*, type **3** to access the *Basic Configuration* menu.

```

BreezeACCESS (AU-I)
Official Release Version - 2.2.6
Release Date:  Mon Apr 24 21:52:01 2000

Basic Configuration
=====
1 - IP Address
2 - Subnet Mask
3 - Default Gateway Address
4 - ESSID
5 - Maximum Data Rate
6 - Frequency Offset
7 - Hopping Shift
8 - Hopping Sync
9 - Hopping Set
A - Power Level
G - Transmit Antenna
S - Show Basic Configuration
BreezeACCESS >>>

```

**Figure 3-2. Basic Configuration Menu**

2. From the *Basic Configuration* menu, type **4** to access the *ESSID* selection screen. Enter the required ESSID.
3. Type **1** to access the *IP Address* selection screen. Enter the required IP address.
4. Type **2** to access the *Subnet Mask* selection screen. Enter the required subnet mask.
5. Type **3** to access the *Default Gateway Address* selection screen. Enter the required default gateway address.
6. Type **7** to access the *Hopping Shift* selection screen. Enter the required Hopping Shift (AU-I units only).

7. Type **9** to access the *Hopping Set* selection screen. Enter the required hopping set (AU-I units only).
8. Type **G** to access the *Transmit Antenna* selection screen. Enter the required selection (0 - use two antennas, 1 - use antenna #1, 2 - use antenna #2).

### **3.3 Reset Unit**

1. From the *main menu*, type **2** to access the *Unit Control* menu.
2. Type **1** to access the *Reset Unit* menu. Type **1** to reset the unit so that new configuration settings are applied.

---

**Note:** *Should you make any mistakes during configuration or encounter any problems associated with system configuration parameters, you may configure the unit back to the factory defaults, as follows:*

*Type 2 in the Unit Control menu to access the Set Factory Defaults menu. Type in 2 (Set Factory defaults-Full) to load the default values. Reset the unit for the factory defaults values to take effect.*

---

## 4. ALIGNING THE ANTENNA

Omni and low gain antennas do not require alignment due to their wide radiation pattern. High gain antennas have a narrow beamwidth, necessitating an alignment procedure in order to optimize the link.

For Subscriber Units with directional antenna(s), you can either use the LED indicators on the front panel of the unit or view the Received Signal Strength Indication (RSSI) on the monitor. In most installations, alignment using the LEDs is sufficient. The RSSI reading can be used when finer alignment is required.

---

***Note:** Antenna alignment of the Subscriber Unit is possible only after the Access Unit you wish to associate with is operational and the ESSID was properly configured.*

---

### 4.1 Aligning the Antenna Using the LEDs

1. Synchronize the units by aligning the antenna manually to point to the base station until the WLNK indicator LED on the front panel of the unit illuminates.
2. Rotate the antenna left and/or right until you reach the point of signal quality reading on the quality (QLT) LEDs. The higher the number of illuminated LEDs the better is the quality of the link. Make sure that at all times, the front of the antenna faces the general direction of the Access Unit.
3. For proper operation, at least one (L) LED should be illuminated. If this is not possible, improve the link quality by placing the antenna at a higher point or in a different location.
4. After the antenna is optimally aligned, tighten the U-bolts (or metal band) to secure the antenna to the pole.

## 4.2 Aligning the Antenna Using the Site Survey Menu

1. Start the Monitor program as described in Section 3.1.
2. From the *main menu*, type 4 to access the *Site Survey* menu. Type 4 to start the *Continuous RSSI Display*. Each line in the display includes the number of frames that were received since the last measurement (total Rx) and the average RSSI for these frames.
3. Rotate the antenna left and/or right until you reach the point of maximum RSSI reading. Make sure that at all times, the front of the antenna faces the general direction of the Base Station.
4. For proper operation, the RSSI reading should be at least 52 units. When the maximum reading is less than 52 units, try to improve it by placing the antenna at a higher point or in a different location. For best performance it is recommended that the RSSI be higher than 76.
5. Press the **Esc** key to stop the test.
6. Tighten the U-bolts (or metal band) over the antenna to secure it to the pole.



## 5. MAXIMUM DATA RATE CONFIGURATION

1. If the average RSSI reading using the Average RSSI Continuous Display is lower than 76, the default data rate of 3 Mbps is too high and the data rate of the unit should be configured accordingly:
2. From the *main menu*, type **3** to access the *Basic Configuration* menu. Type **5** to access the *Maximum Data Rate* menu.
  - i) Type **3** (3Mbps) if the RSSI reading is higher than 76 units.
  - ii) Type **2** (2Mbps) if the RSSI reading is between 66 to 76 units.
  - iii) Type **1** (1Mbps) if the RSSI reading is lower than 66 units.
3. Reset the unit for the new configuration to become effective.

## 6. VERIFYING PROPER OPERATION

### 6.1 General

After completing the installation as described above, and after connecting the unit to the AC Mains, the system starts operation. To verify correct operation, view the LED panel located on the front panel of the unit. Table 1 lists the various LED states.

**Table 1. SU-I LEDs**

Name	Description	Functionality	
PWR	Power supply	On – After successful power up Off – Power off	
WLNK	Synchronization	Off – No Synchronization On – Synchronization with Access unit	
ETH	Ethernet activity	Blinking – Reception of data from Ethernet LAN Off – No reception of data from Ethernet LAN	
QLT	Quality of received RF signal	H ○ M ○ L ○  H ○ M ○ L ●  H ○ M ● L ●  H ● M ● L ●	very low quality reception or not synchronized with Access Unit, less than -81 dBm  low quality reception (usually enabling 1Mbps traffic) from -81 to -77 dBm  medium quality reception (usually enabling 2 Mbps traffic) from -77 to -65 dBm  high quality reception (usually enabling 3 Mbps traffic) greater than -65 dBm

### 6.2 Verifying Data Connectivity

From the user's PC or from a portable PC connected to the unit, Ping the unit or try to connect it to the Internet.

## 7. SPECIFICATIONS

### 7.1 Radio

Frequency	2.500GHz – 2.686GHz	
Radio Access Method	FH-CDMA or TDMA	
Operation Mode	Time Duplex Division	
Sub-Channel Bandwidth	1 MHz	
Frequency Setting Resolution	1 MHz	
Output Power (at antenna port)	23 dBm typical. Power Control range: 20 dB	
Sensitivity (dBm at antenna port, BER $1E10^{-6}$ )	1Mbps 2Mbps 3Mbps	-83 -76 -67
Data Rate	3Mbps max	
Modulation	Multilevel GFSK	

### 7.2 Data Communication

Standard Compliance	IEEE 802.3 CSMA/CD
---------------------	--------------------

### **7.3 Configuration and Management**

Local Management	Via MON port, Monitor program using terminal emulation
Remote Management	SNMP, Telnet, TFTP
Remote Management Access	From Wired LAN, Wireless Link
SNMP Agents	MIB II, Bridge MIB, Private MIBs
Accounting	RADIUS compatible client
Security	Authentication and filtering
Software upgrade	TFTP download

### **7.4 Interfaces**

RF	2 x SMA jacks
Ethernet	10Base-T (RJ-45)
Monitor	3-pin low profile
Power	DC socket for a power transformer

### **7.5 Electrical**

External power Supply	100-250 VAC, 50-60 Hz, 0.5 A
Input voltage	5VDC

### **7.6 Mechanical**

Without antenna and power supply	13cm x 8.6cm x 3cm
----------------------------------	--------------------

### **7.7 Environmental**

Operating Temperature	0°C to 40°C
Operating Humidity	5%-95% non condensing



## APPENDIX A. OPTIONAL RF ACCESSORIES

This appendix introduces some of the accessories available for specific installations, and describes how to install them.

### A.1 TPA 24 Transmit Power Amplifier (Booster)

The TPA 24 Transmit Power Amplifier is used to amplify the transmit power to a fixed output of 24 dBm (250 mW). The TPA 24 is especially useful when long RF cable runs are required. In addition, the TPA 24 simplifies antenna alignment by enabling the use of wider dispersion transmit antennas. The TPA 24 is internally protected against lightning and voltage surge protection.

The TPA 24 comes in two models:

- The TPA 24 NL receives input power in the range of -10dBm to 0dBm.
- The TPA 24 NH receives an input power of 0dBm to +10dBm.

Both models amplify the input power to a fixed output level of 24dBm (250mW).

The TPA is powered by 12VDC carried from the power inserter by the RF cable.

---

**Note:** *The TPA 24 is not available in the USA due to FCC regulations.*

---

When used in compliance with ETSI regulations, the TPA 24 can be connected to cables and antennas resulting in a total transmitted power of 20dBm (100 mW) EIRP.

### A.1.1 Installing the TPA 24

1. Choose one of the TPA 24 models according to the power level at the input of the booster. In general the NH model is used. For installations with long cables (high attenuation), the NL model should be used.
2. Choose one of the antenna connectors to be used for transmission.
3. Use the terminal to set the unit's transmit diversity option to the selected antenna.

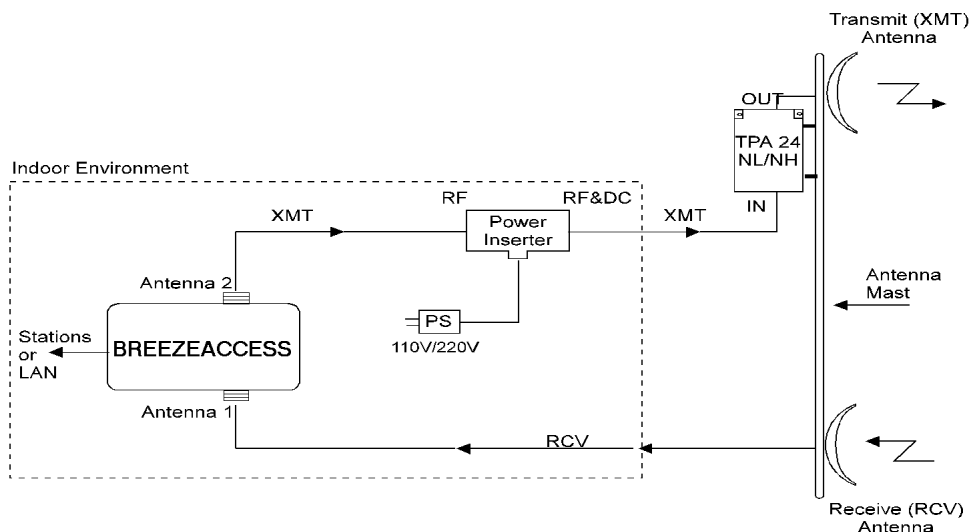

**Figure A-1. TPA 24 Installation**

4. Connect the TPA 24 RF output directly to the transmit antenna.
5. Attach the TPA 24 RF input to the Power Inserter with the RF cable. The Power Inserter must be installed indoors.
6. Connect the RF cable leading from the Power Inserter to the transmit antenna on the BreezeACCESS unit.

7. Plug the power cable leading from the Power Inserter into any available 110/220V outlet. The power supply must be installed indoors.
8. For reception, use a separate antenna connected to the other antenna connector of the BreezeACCESS unit.

---

**Note:** *Installations exceeding regulations set by local authorities expose the installer and the user to potential legal and financial liabilities.*

---

### A.1.2 TPA 24 Transmit Power Amplifier Specifications

Models used with the BreezeACCESS Series	<ul style="list-style-type: none"> <li>• TPA 24 NL</li> <li>• TPA 24 NH</li> </ul>
Input Power	<ul style="list-style-type: none"> <li>• TPA 24 NL: -10dBm - 0dBm (Low input)</li> <li>• TPA 24 NH: 0dBm - +10dBm (High input)</li> </ul>
Output Power	24 dBm (250mW) (fixed output level)
Input Impedance	50W
Output Impedance	50W (DC short)
Operating Temperature	-20° to 50°C
Power Requirements	12V; 420 mA (Power Supply and Power Inserter are supplied with models TPA-24 NL and TPA-24 NH)
Connectors	<ul style="list-style-type: none"> <li>• TPA 24: IN - N-type Male; OUT - N-type Female</li> <li>• Power Inserter: RF - N-type Male; RF&amp;DC - N-type female</li> </ul>
Dimensions	70mm x 150mm x 25mm (2.8"x 6"x 1")
Operating Environment	<ul style="list-style-type: none"> <li>• TPA 24 - For outdoor/indoor use</li> <li>• Power Supply - For indoor use</li> <li>• Power Inserter - For indoor use</li> </ul>

---

**Note:** *All specifications are subject to change without notice.*

---



## **A.2 LNA 10 Low Noise Receive Amplifier**

The LNA 10 is a high-performance, low-noise preamplifier designed to enhance fringe area reception and provide additional gain on the receive antenna. Its exceptionally small size and light weight enables it to be directly mounted on the antenna by means of the female RF IN connector. Power is obtained through an RG-59 coaxial cable connected to the power supply. The LNA 10 is internally protected against lightning and voltage surge protection.

The Power Supply (PS) and Power Inserter are supplied with the LNA 10. The RG-59 coaxial cable with F-type connector is not supplied and must be purchased separately.

### **A.2.1 Installing the LNA 10**

Before installing the LNA 10, the following steps must be taken:

1. Choose one of the antenna connectors to be used for reception. This connector is called the receive antenna of the unit. The other connector is called the transmit antenna of the unit.
2. Use the terminal to set the unit's transmit diversity option to the selected antenna (see Section). This prevents transmission from going through the LNA 10.
3. Connect the LNA 10 RF input directly and as close as possible to the receive antenna.
4. Attach the LNA 10 RF output directly to the RF cable going down to the receive antenna connector on the BreezeACCESS unit.
5. Connect the RG-59 coaxial cable which leads down to the Power Inserter to the Signal and Power out connector on the LNA 10.
6. Connect the Power Inserter to the power supply (both are indoor units).
7. For transmission, use a separate antenna connected to the other antenna connector (transmit antenna) of the BreezeACCESS unit.

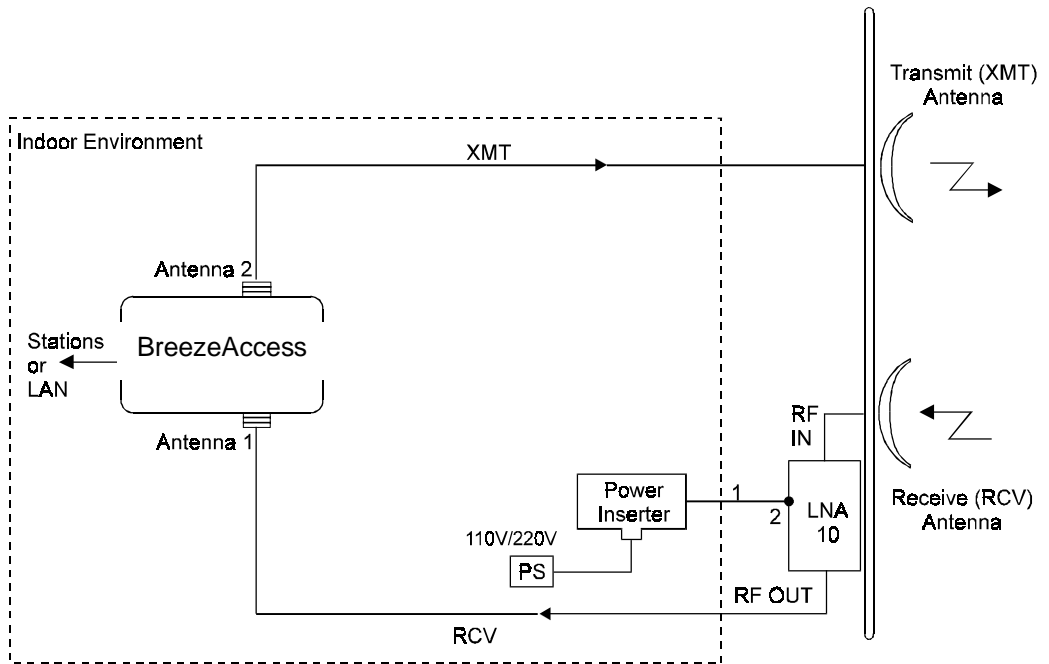

- 1 - RG-59 Coax, F-type Connector
- 2 - OUT (Signal and Power)

Figure A-2. LNA 10 Connections Diagram

## A.2.2 LNA 10 Low Noise Receive Amplifier Specifications

Gain	10dB
Noise Figure	1.5dB Type, 2dB Max.
Response Flatness	$\pm 1.5$ dB
Max. RF Input Level	-15dBm
Input Impedance	50W
Output Impedance	50W
Connectors	<ul style="list-style-type: none"> <li>• LNA-10: RF IN: N-type, female RF OUT: N-type, male Signal and Power IN: not in use Signal and Power OUT: F-type, female</li> <li>• Power Inserter: To CONV - F-type, female To TV - F-type, female</li> </ul>
Power Supply: Required Voltage Required Current	+12V to +28Vdc 20mA
Operating Temperature	-20° C to +50° C
Dimensions	60mm x 35mm x 25mm (2.3"x 1.3"x 1")
Operating Environment	LNA 10 - outdoor/indoor Power Supply - indoor Power inserter - indoor

*Note:* All specifications are subject to change without notice.

## A.3 RFS 122 Radio Frequency Splitter

The RFS 122 Radio Frequency Splitter is used to split the RF signal generated by a transmitter into two signals. These signals are then sent to two different and independent antennas. The RFS 122 enables radio transmission using two directional antennas connected to the same port of the BreezeACCESS unit. Similarly, the splitter is used to combine two receiving antennas to one antenna connector.

Before installing the RFS 122, use the terminal to configure the unit's transmit diversity option to transmit through Antenna 2 only, and connect the RFS 122 to antenna connector 2.

### A.3.1 Installing the RFS 122

The following diagram illustrates RFS-122 installation.

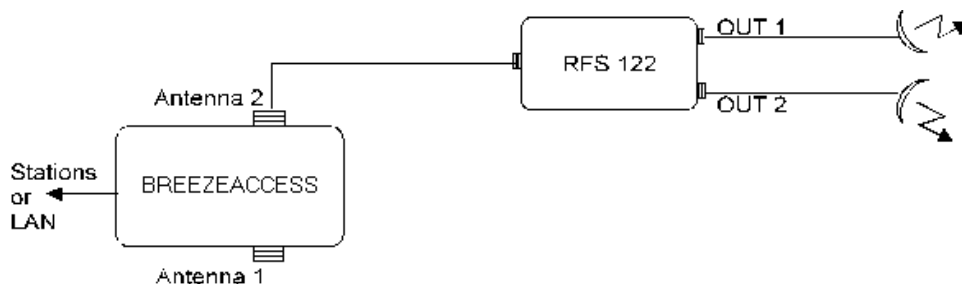

**Figure A-3. RFS-122 Connection Diagram**

### A.3.2 Specifications for RFS 122 Radio Frequency Splitter

Insertion Loss	3.8dB max.
Isolation	19dB min.
Power Rating	10 W max.
Internal Load Dissipation	125 mW max.
Input Impedance	50W
Output Impedance	50W
Connectors	<ul style="list-style-type: none"><li>• SUM: N-type, Male</li><li>• PORTS: N-type, Female (on each port)</li></ul>
Operating Temperature	-20° C to +85° C
Dimensions	51mm x 51mm x 19mm (2" x 2" x 0.75")
Operating Environment	Outdoor/Indoor

## A.4 AL 1 Lightning Arrestor

The AL 1 Lightning Arrestor is used to protect transmitters and receivers from transients originating from lightning or EMP.

The AL 1 is gas tube-based and is not radioactive. The gas discharge tube can sustain several transients if the time period between transients is sufficient to allow the tube to cool down.

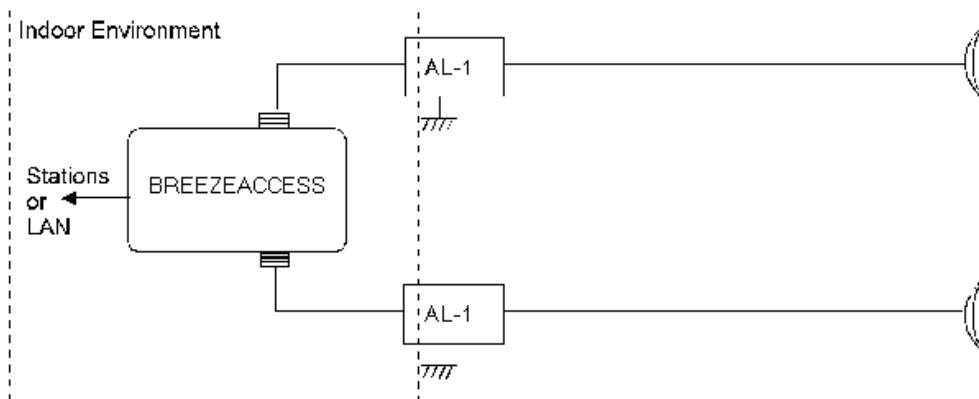

**Figure A-4. AL-1 Connection Block Diagram**

One of the female-type N connectors is mounted directly through a hole in the shelter wall and held in place with a lockwasher and nut.

#### A.4.1 AL 1 Lightning Arrestor Specifications

Turn on voltage	75V
Insertion loss	0.3dB typical
DC path from input to output	existing
Operating Temperature	-55° C to +70° C
Dimensions	67.5mm x 25mm x 25mm (2.7" x 1" x 1")
Connectors	<ul style="list-style-type: none"><li>• Antenna Port: N-type, Female</li><li>• Equipment Port: N-type, Female</li></ul>
Operating Environment	Indoor/Outdoor
Grounding	One of the female-type N connectors is mounted directly through a hole in the shelter wall and held in place with a lockwasher and nut.

---

*Note: All specifications are subject to change without notice.*

---

## A.5 AMP 2440 Bi-Directional Amplifier

The AMP 2440 is a bi-directional amplifier designed for extending the range of BreezeACCESS wireless LAN radios.

The unit operates automatically, therefore there is no need for manual adjustments. The units receive signal gain and also provide transmit power amplification.

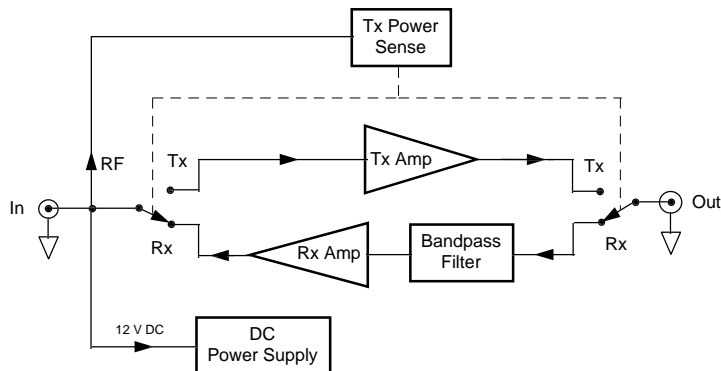

**Figure A-5. AMP 2440 Functional Block Diagram**

The amplifier is installed directly at the antenna's feed point, providing maximum effectiveness of transmit power which compensates for signal loss in the transmitter cable to the antenna. Likewise, the Low Noise Amplifier (LNA) in the AMP 2440 boosts the receive signal right at the antenna prior to experiencing the loss in the transmission cable to the radio. This gain also overcomes the losses in the transmission cable between the amplifier and the radio. In fact, use of the AMP 2440 bi-directional amplifier will actually increase the receiver sensitivity of the radio by 4dB. The ultimate result is the best possible noise figure and maximum receiver sensitivity. System gains of up to 30 dB are typical when amplifiers are used at each end of a link.

The AMP 2440 bi-directional amplifier is completely weatherproof and can be bolted to the antenna mast or tower leg using the U-bolt included. The connectors face down so that gravity will drain all water away from the amplifier enclosure. This will prevent water from settling on the face of the unit. Likewise, since the



LEDs are also facing downward they can be checked for operation from the bottom of the mast.

DC Power to the amplifier is supplied through the transmission cable, using an indoor power supply and DC Injector. The amplifier unit also contains its own integral lightning protection and DC surge protection to ensure years of continuous outdoor operation.

BreezeCOM provides the user with two models of the AMP 2440 bi-directional amplifier:

- AMP 2440-500. Provides 500 mW (+27dBm) maximum output
- AMP 2440-250. Provides 250 mW (+24dBm) maximum output

The transmit gain for **both** models is 12 - 15dB. Full output power of approximately 500 mW is achieved with 30 mW (+15 dBm) input to the amplifier; 8 mW (+9dBm) for the AMP 2440-250 model. The amplifier goes into limiting at this point and higher input power results in only slight increases in the output power. Up to 100 mW of power may be safely applied directly to the amplifier input without any damage on either model.

The AMP 2440 bi-directional amplifier comes with power supplies that have standard 2.1 mm barrel plugs (which are configured as positive (+) tip and negative (-) outer conductor). Although normally supplied with a power supply, any regulated 12 Volt DC 1 amp supply can be used. The power supply can be used with 110 or 240 VAC power.

### A.5.1 Installing the AMP 2440 Bi-Directional Amplifier

The AMP 2440 bi-directional amplifier is designated for installation by professional radio installers. Several key factors unique to the particular installation determine the power level at the input of the amplifier. The most important consideration is the cable loss in the transmission cable between the radio and the pole mounted amp. The installer should understand these and other factors when computing the input power to the amplifier.

The AMP 2440 bi-directional amplifier can be mast mounted using the steel U-bolt included with the unit, as shown in Figure A-7. The AMP 2440 bi-

directional amplifier should be installed with the connectors facing downward. After placing the assembly on the mast, use an open-end wrench to carefully tighten the nuts. Take care not to over-tighten the nuts or you may inadvertently strip the threads.

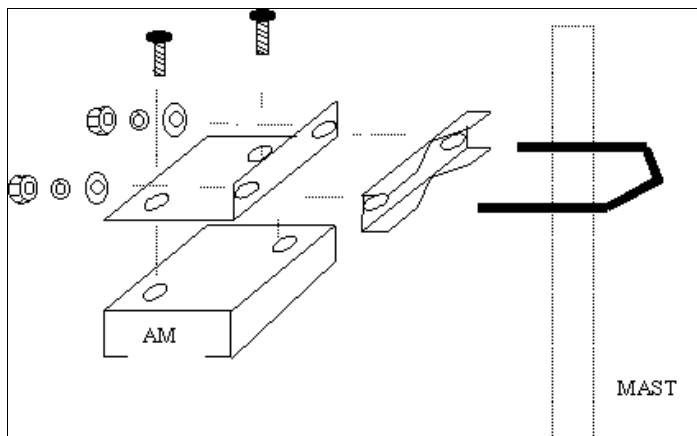

**Figure A-6. AMP 2440 Installation and Mounting**

---

**WARNING!** *It is very important to waterproof the RF connectors on the AMP 2440 bi-directional amplifier.*

---

However, it is recommended that you do not seal the connectors until after all system tests have been performed. Be sure to use the high quality weather resistant vapor wrap included with you amplifier kit to seal all the outside connections.

The DC Power Injector is not in a waterproof enclosure and must be protected from the weather. It can be permanently mounted to a surface using the mounting flanges.

---

**Note:** *When using the 24dB gain dish antenna in the United States, the external filter (P/N: SPF-1) must be installed to comply with FCC emission requirements.*

---

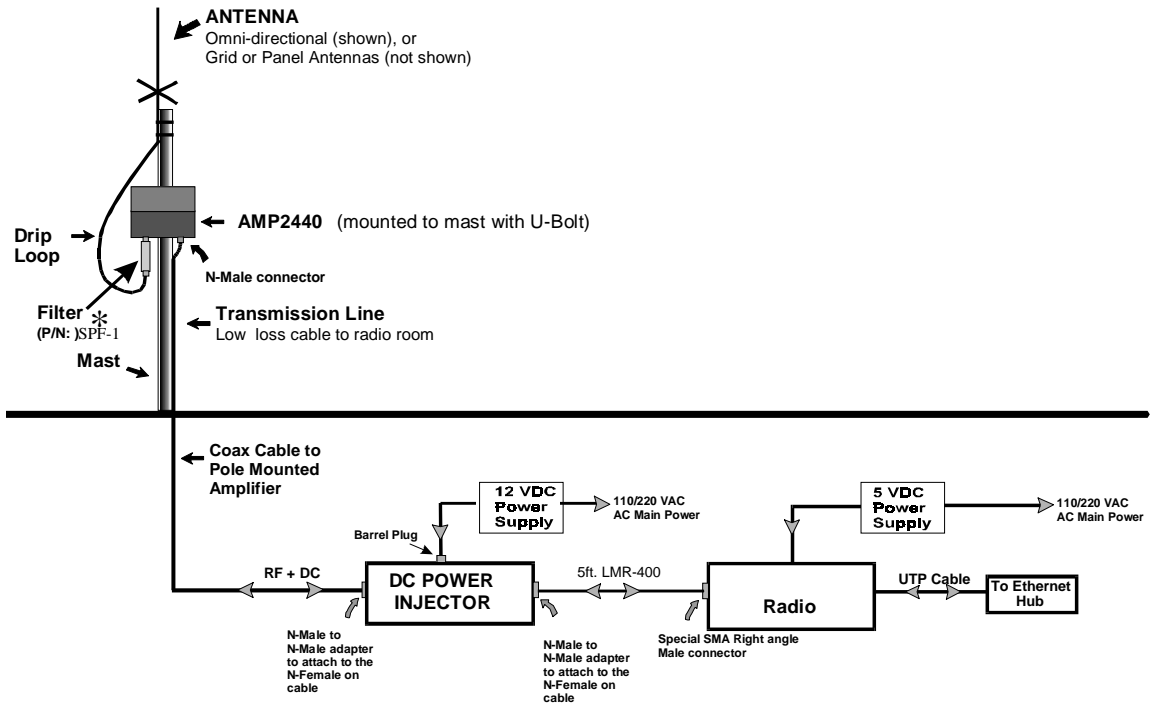

\* Filter is required in the United States when the 24dB grid dish antenna is used in order to comply with FCC emission requirements.

Figure A-7. AMP 2440 Installation Details

## A.5.2 AMP 2440 Bi-Directional Power Amplifier Specifications

<b>General Specifications</b>	
Operating Range	2400-2483 MHz
Operating Mode	Bi-directional, half-duplex. Senses RF carrier from transmitter and automatically switches from receive to transmit mode.
Connectors	N-female
Indicators	TX and RX LEDs on both the amplifier and the DC bias injector
Lightning Protection	Direct DC ground at antenna connector
DC Surge Protection	600 Watt TVS at 12 VDC input from transmission cable
<b>Transmitter Amplifier</b>	
Transmit Gain	Up to 15 dB
Frequency Response	+/-1 dB over operating range
Transmit Output Power	<ul style="list-style-type: none"> <li>• AMP 2440-500 model: 500 mW *</li> <li>• AMP 2440-250 model: 250 mW.</li> </ul>
Transmit Input Power	3 mW minimum, 100mW maximum (+3dBm required to cause TX mode)
<b>Receiver Low Noise Amplifier (LNA)</b>	
Receive Gain	18 dB typical
Frequency Response	+/-1 dB over operating range
Noise Figure	3.5 dB approximately
Third Order Intercept	20 dBm

<b>Mechanical and Environmental</b>	
Operating Temperature	-20°C to +60°C
Power	12VDC @ 650mA or 105-240 VAC from power supply provided with kit
Dimensions	Amplifier: 3.85" x 2.52" x 1.46" DC Power injector: 4.42" x 2.40" x 1.22"
Mounting Bracket for amplifier	Accommodates pole/mast diameters from 3/4" to 3"
Kit Weight	Approx. 1.5 lb. with U-bolts

## APPENDIX B. USING TELNET

Use the following procedure to connect to BreezeACCESS units via a Telnet session.

1. Connect the PC to the Ethernet port of the unit (or the hub to which the unit is connected) using a straight Ethernet cable. If you connect the PC directly to a unit that is normally connected to a hub, use a crossed Ethernet cable. You may also connect the PC to any Ethernet port on the network and communicate with the unit to be managed via the wired or wireless media.
2. Make sure that the IP parameters of the PC are configured to enable connectivity with the unit.
3. Run a Telnet application and use the IP address of the unit to be managed as the Host Name.
4. Set Port to *Telnet* (this is the default).
5. Set Terminal Type to *VT100* (this is the default).
6. Enter the Service Provider password.
7. When the password is recognized, the following message is displayed:

You have entered.
8. Press **Enter**, the Breeze ACCESS Monitor is displayed on the screen.

To exit the Telnet session, choose *Disconnect* from the *Connect* menu. (The session is terminated automatically, after a specific time of inactivity determined by the Log-out Timer).