



# ***BreezeACCESS MMDS***

***Indoor Subscriber Units***

***SU-I/ID-MMDS Series***

# **Installation Manual**

July, 2000

Cat. No. 213099

© 2000 by BreezeCOM Ltd. All rights reserved.

No part of this publication may be reproduced in any material form without the written permission of the copyright owner.

## **Trade Names**

BreezeACCESS, BreezeNET, BreezeLINK, BreezeVIEW and WIX are trade names of BreezeCOM Ltd. Other brand and product names are registered trademarks or trademarks of their respective companies.

## **Statement of Conditions**

The information contained in this manual is subject to change without notice. BreezeCOM shall not be liable for errors contained herein or for incidental or consequential damages in connection with the furnishing, performance, or use of this manual or equipment supplied with it.

## **Warranty**

In the following warranty text, “the Company” shall mean:

- BreezeCOM Ltd., for products located outside the USA.
- BreezeCOM Inc., for products located in the USA.

This BreezeACCESS product is warranted against defects in material and workmanship for a period of one year from date of purchase. During this warranty period the Company will, at its option, either repair or replace products that prove to be defective.

For warranty service or repair, the product must be returned to a service facility designated by the Company. Authorization to return products must be obtained prior to shipment. The buyer shall pay all shipping charges to the Company and the Company shall pay shipping charges to return the product to the buyer within the USA.

The Company warrants that the firmware designed by it for use with the unit will execute its programming instructions when properly installed on the unit. The Company does not warrant that the operation of the unit or firmware will be uninterrupted or error-free.

## **Limitation of Warranty**

The foregoing warranty shall not apply to defects resulting from improper or inadequate maintenance by the buyer, buyer supplied interfacing, unauthorized modification or misuse, operation outside of the environmental specifications for the product, or improper site preparation or maintenance. No other warranty is expressed or implied. The company specifically disclaims the implied warranties of merchantability and fitness for any particular purpose.

BreezeCOM shall not be liable to any person for any special or indirect damages, including, but not limited to, loss of profits or revenues, loss of use or damage to any associated equipment, cost of capital, cost of substitute products, facilities or services, downtime costs or claims resulting from any cause whatsoever arising from or in any way connected with the manufacture, sale, handling, service, repair, maintenance or use of the products. In no event shall the company's liability exceed the purchase price denoted on the invoice.

## **Electronic Emission Notice**

This device complies with Part 15 of the FCC rules. Operation is subject to the following two conditions:

1. This device may not cause harmful interference.
2. This device must accept any interference received, including interference that may cause undesired operation.

## **FCC Radio Frequency Interference Statement**

This equipment has been tested and found to comply with the limits for a class A digital device, pursuant to Part 15 of the FCC rules. These limits are designed to provide reasonable protection against harmful interference when the equipment is operated in a commercial environment. This equipment generates, uses, and can radiate radio frequency energy and, if not installed and used in accordance with the instruction manual, may cause harmful interference to radio communications. Operation of this equipment in a residential area is likely to cause harmful interference in which case the user will be required to correct the interference at his own expense.

## **Information to User**

Any changes or modifications of equipment not expressly approved by the manufacturer could void the user's authority to operate the equipment.

## **Safety Considerations**

For the following safety considerations, "Instrument" means the **BreezeACCESS Subscriber or Access** unit components and their cables.

## **Caution**

To avoid shock, do not perform any servicing unless you are qualified to do so.

To comply with FCC RF exposure requirements in section 1.1307, a minimum separation distance 20cm (8 inches) is required between this antenna and all persons.

## **Grounding**

Before connecting the instrument to the power line, verify that a suitable power cord is being used (the protective earth terminal of this instrument must be connected to the protective conductor of the power cord). The mains plug shall only be inserted in a socket outlet provided with a protective earth contact. If an extension cord (power cable) is used make sure it has a protective conductor (grounding).

## **Line Voltage**

Before connecting this instrument to the power line, make sure that the voltage of the power source matches the requirements of the instrument: 100-250 VAC, 50-60 Hz.

## **Radio**

The instrument transmits radio energy during normal operation. To avoid possible harmful exposure to this energy, do not stand or work for extended periods of time in front of its antenna. The long-term characteristics or the possible physiological effects of Radio Frequency Electromagnetic fields have not been yet fully investigated.

## **Antenna Installation and Grounding**

Be sure that the outdoor antennas and the supporting structure are properly installed to eliminate any physical hazard to either people or property. Verify that the antenna mast is grounded so as to provide protection against voltage surges and static charges. Make sure that the installation of the antenna and cable is performed in accordance with all relevant national and local building and safety codes.

# Table of Contents

---

<b>1. INTRODUCTION .....</b>	<b>1</b>
<b>2. BASIC INSTALLATION .....</b>	<b>2</b>
2.1 Packing List .....	2
2.2 Other Required Items .....	2
2.3 Installation Overview .....	3
2.4 Installation Guidelines .....	3
2.4.1 Location of the Unit and Antenna(s) .....	3
2.4.2 Location of the Antenna(s) .....	4
2.4.3 Antenna Diversity .....	4
2.4.4 Antenna Polarization.....	5
2.4.5 Antenna Seal .....	5
2.4.6 Lightning Protection .....	5
2.5 Wall Mounting the Unit .....	6
2.6 Connecting Antenna(s) to the Units (SU-ID units only).....	8
2.7 Connecting the Unit to the Power Supply and to the CPE.....	9
<b>3. CONFIGURING SYSTEM PARAMETERS .....</b>	<b>10</b>
3.1 Getting Started with the Local Terminal.....	10
3.2 Configuration Parameters .....	12
3.3 Reset Unit.....	14
<b>4. ALIGNING THE ANTENNA .....</b>	<b>15</b>
4.1 Aligning the Antenna Using the LEDs .....	15
4.2 Aligning the Antenna Using the Site Survey Menu.....	16
<b>5. MAXIMUM DATA RATE CONFIGURATION .....</b>	<b>17</b>

<b>6. VERIFYING PROPER OPERATION.....</b>	<b>18</b>
6.1 Verifying Data Connectivity .....	18
<b>7. SPECIFICATIONS .....</b>	<b>19</b>
7.1 Radio .....	19
7.2 Data Communication .....	19
7.3 Configuration and Management .....	20
7.4 Interfaces .....	20
7.5 Electrical .....	20
7.6 Mechanical.....	20
7.7 Environmental.....	20
7.8 Standards Compliance, General.....	21
APPENDIX A. AL 1 Lightning Arrestor.....	22
APPENDIX B. USING TELNET .....	24
APPENDIX C. MMDS CHANNELS AND FREQUENCIES .....	25

## **Table of Figures**

---

Figure 2-1. Wall Mounting the Unit .....	7
Figure 2-2. Wall Mounting Plate .....	7
Figure 2-3. Tightening the Cable(s) to the Connector(s).....	8
Figure 3-1. Main Menu .....	11
Figure 3-2. Basic Configuration Menu .....	13
Figure A-1. AL-1 Connection Block Diagram .....	22





# 1. INTRODUCTION

This manual describes installation guidelines for BreezeACCESS/MMDS SU-I and SU-ID Subscriber Units.

The BreezeACCESS IP Broadband Wireless Local Loop (WLL) system allows access service providers to provide high-speed IP connectivity services to their subscribers. To support IP-based services effectively BreezeACCESS systems employ wireless packet data switching technology.

The BreezeACCESS MMDS line of products uses Frequency Hopping Spread Spectrum radios that operate in Time Duplex Division (TDD) mode in the 2.500GHz – 2.686GHz frequency range.

The SU-I/ID-MMDS line of Subscriber Units comprises compact units that are designed for indoor installation. SU-I units include two 2dBi integrated antennas. SU-ID units have two RF connectors for detached diversity antennas. Detached antennas can be installed either indoors or outdoors, depending on the specific site conditions.

The SU-I/ID-MMDS is available in two frequency bands:

- SU-I/ID-MMDSa products operate in the 2.500 - 2.600 GHz frequency band.
- SU-I/ID-MMDSb products operate in the 2.596 - 2.686 GHz frequency band.

The SU-I/ID-MMDS series includes the following products:

- SU-I/ID-1D-MMDSa/b: supports a single Ethernet device
- SU-I/ID-8D-MMDSa/b: supports up to eight Ethernet workstations/PCs
- SU-I/ID-BD-MMDSa/b: supports a LAN (a bridge functionality)

---

**Note:** *The information contained in this manual is applicable to BreezeACCESS MMDS units with software release 2.5.*

---

## **2. BASIC INSTALLATION**

### **2.1 Packing List**

The SU-I/ID units are shipped with the following units and accessories. The exact packing list varies depending on system configuration and ordered equipment.

- SU-I unit (with two integral antennas) or SU-ID unit (without antennas)
- A 5 VDC universal power supply transformer
- Mounting bracket for wall or ceiling installation
- A torque key for antenna connectors (SU-ID units)

### **2.2 Other Required Items**

The following items must be available for the installation

- Antenna(s)\*and RF cable(s)\*for SU-ID units (according to specific installation requirements)
- A PC with terminal emulation program
- A monitor cable\* (supplied with each AU)
- An Ethernet cable (straight)
- Installation tools and materials

---

*Items marked with an asterisk (\*) are available from BreezeCOM.*

---

## 2.3 Installation Overview

Standard installation involves the following steps:

1. Verify that all components of the packing list, described in Section 2.1, are intact and verify availability of the required items listed in Section 2.2.
2. Install the unit and antenna(s) in optimal locations as described in Section 2.4.
3. Connect the antenna(s) to the unit as described in Section 2.6.(SU-ID units)
4. Connect the power supply to the unit as described in Section 2.7.
5. Connect the Ethernet port to the unit as described in Section 2.7.
6. Configure the basic system parameters as described in Section 3.
7. Align the antenna(s) for optimal connectivity and configure the Maximum Data Rate if applicable, as described in Chapters 4 and 5.
8. Check the functionality of the unit as described in Chapter 6.

## 2.4 Installation Guidelines

This section describes the installation guidelines and the various considerations that must be taken into account when planning the installation.

### 2.4.1 Location of the Unit and Antenna(s)

- The unit can be placed on a shelf, or can be attached to the ceiling or a wall using a mounting bracket. SU-ID units should be installed as near to the antenna(s) as possible to minimize loss of RF power in the cable(s).
- Keep the units well away from sources of heat, such as radiators, air-conditioners, etc.

- For most applications, the most convenient choice is to use SU-I units, equipped with two integral 3dBi omni antennas.

### **2.4.2 Location of the Antenna(s)**

- Any physical object in the path between two units can cause signal attenuation. Common obstructions are buildings and trees. If a unit's antenna is installed indoors, the walls and/or windows between the two sites are physical obstructions. If the antenna is positioned outdoors, any buildings or other physical structure such as trees, mountains or other natural geographic features higher than the antenna and situated in the path between the two sites can constitute obstructions.
- Install indoor antennas as close as possible to a window (or wall if a window is not accessible) facing the required direction. Avoid metal obstacles such as metal window frames or metal film anti-glare windows in the transmission path. Install outdoor antennas high enough to avoid any obstacles, which may block the signal.
- Position the antennas clear of metal furniture and away from moving metal objects such as metal fans or doors.
- For best performance, position the antennas clear of radiation sources that emit in the 2.5 - 2.7 GHz frequency band, such as microwave ovens.

### **2.4.3 Antenna Diversity**

In applications where no multipath propagation is expected, a single antenna is sufficient to ensure good performance levels. However, in cases where multipath propagation exists, BreezeCOM recommends that two antennas be used. This takes advantage of space diversity capabilities. By using two antennas per unit, the system can select the best antenna on a per-packet basis (every several milliseconds).

Multipath propagation is to be expected when there are potential reflectors between the Access Unit and Subscriber Units. These reflectors may be buildings or moving objects such as airplanes and motor vehicles. If this is the case, the radio signal does not travel in a straight line, but is reflected or deflected off of the object, creating multiple propagation paths.

When installing a single antenna, modify the transmit diversity option to either antenna 1 or antenna 2, according to the antenna being used.

#### **2.4.4 Antenna Polarization**

Antenna polarization must be the same at either end of the link. In most applications, the preferred orientation is vertical polarization. Above-ground propagation of the signal is better when it is polarized vertically. To verify antenna polarization, refer to the assembly instructions supplied with the antenna set. For screw-on and detached omni antennas, make sure that the antennas are extended upward vertically in relation to the floor to achieve vertical polarization.

#### **2.4.5 Antenna Seal**

When using outdoor antennas, you must seal the antenna connectors against rain. Otherwise the antennas are not suitable for use in outdoor installations.

#### **2.4.6 Lightning Protection**

Lightning protection is designed to protect people, property and equipment by providing a path to ground for the lightning's energy. The lightning arrester diverts the strike energy to ground through a deliberate and controlled path instead of allowing it to choose a random path. Lightning protection for a building is more forgiving than protection of electronic devices. A building can withstand up to 100,000 volts, but electronic equipment may be damaged by just a few volts.

Lightning protection entails connecting an antenna discharge unit (also called an arrester) to each cable as close as possible to the point where it enters the building. It also entails proper grounding of the arrestors and of the antenna mast (if the antenna is connected to one).

The lightning arrester should be installed and grounded at the point where the cable enters the building. The arrester is connected to the unit at one end and to the antenna at the other end.

The professional installer you choose must be knowledgeable about lightning protection. The installer must install the lightning protector in a way that maximizes lightning protection. BreezeCOM offers the following high-quality lightning arrestor assembly:

BreezeACCESS AL 1 Lightning Arrestor - Part No. 872905 5 ft (1.5m), “N” Male to “N” Female.

---

**Note:** *Detached antennas, whether installed indoors or out, should be installed ONLY by experienced antenna installation professionals who are familiar with local building and safety codes and, wherever applicable, are licensed by the appropriate government regulatory authorities.*

*Failure to do so may void the BreezeACCESS Product Warranty and may expose the end user to legal and financial liabilities. BreezeCOM and its resellers or distributors are not liable for injury, damage or violation of government regulations associated with the installation of detached antennas.*

---

## **2.5 Wall Mounting the Unit**

Use the supplied brackets for wall mounting to install the unit on a wall or a ceiling.

1. Turn the unit so the rear panel is facing you.
2. Unscrew the two screws located at the antennas end of the unit (the top screws).
3. Align the Unit Mounting Slots (see Figure 2-2) with the slots you have just unscrewed.
4. Using the longer screws supplied with the wall mounts, screw the wall mount to the unit.
5. Align the Convenience Mounting Slots (see Figure 2-2) with the nails, push the wall mount against the wall and let it slide down until it rests on the nails.

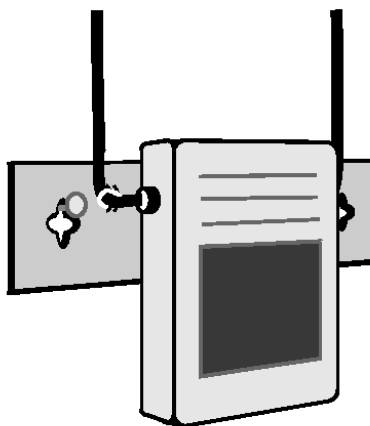

Figure 2-1. Wall Mounting the Unit

Special slots have been added to the wall mounts to allow for unobtrusive cable installation. These slots should be used to fasten cables coming out of the unit to the wall mounts, eliminating loose or tangled cable installations.

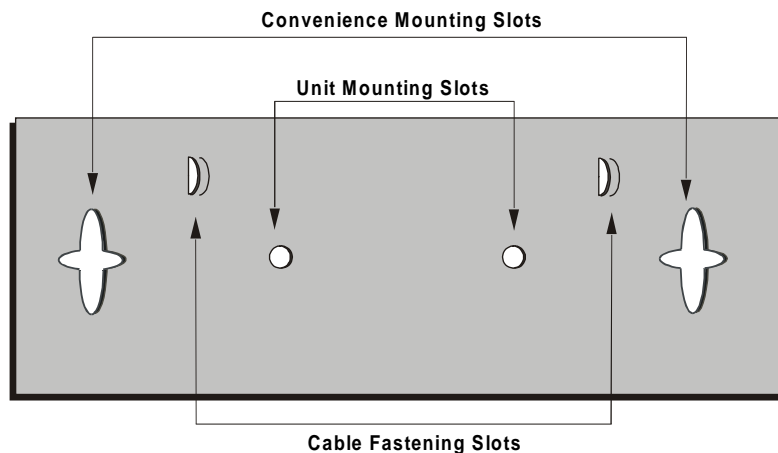

Figure 2-2. Wall Mounting Plate

## 2.6 Connecting Antenna(s) to the Units (SU-ID units only)

For installation convenience, a torque key is included with all BreezeACCESS SU-ID units.

---

**WARNING:** *The use of improper tools for tightening antenna connection cables to BreezeACCESS SU-I units may result in damage to the cable connectors.*

---

Use the included torque key to tighten the cable(s) to the connector(s) on the side of the SU-I unit. The key is designed to prevent over tightening of the screws and protects the connectors from damage.

Tighten the cable(s) to the connector(s) using the torque key.

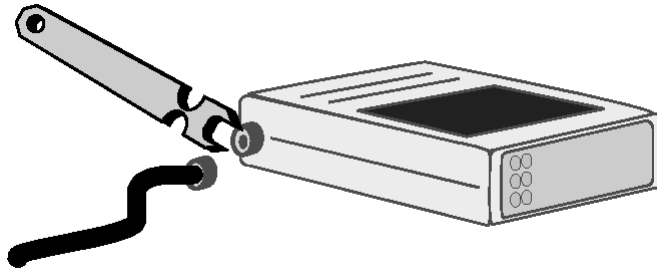

**Figure 2-3. Tightening the Cable(s) to the Connector(s)**

If excessive pressure is applied to tighten the screws, the torque key will break.

---

**Note:** *Do not attempt to tighten the screws any further. This may damage the connectors on the BreezeACCESS SU-ID unit.*

---



## **2.7 Connecting the Unit to the Power Supply and to the CPE**

The unit operates on a power input of 5V DC, supplied by the power transformer included with the unit.

1. Plug the output jack of the power transformer into the DC input jack located on the rear panel of the unit.
2. Connect the supplied universal power transformer to a power outlet - 110/220VAC.
3. Use a straight Ethernet 10BaseT cable to connect a PC (SU-I/ID) or a hub (SU-I/ID-8D or SU-I/ID-BD) to the Ethernet port (marked UTP) located on the rear panel of the unit.

## 3. CONFIGURING SYSTEM PARAMETERS

After completing the installation process, as described in the preceding sections of this manual, proceed with configuration of the basic system parameters.

This manual covers the configuration of basic installation parameters. Refer to the Administration Manual for information related to other parameters.

---

*Note:* Optionally, the product can be configured using Telnet over the Ethernet port, after setting IP address. For further information refer to Appendix B.

---

### 3.1 Getting Started with the Local Terminal

1. Connect one end of the Monitor cable to the MON jack on the rear side of the unit. Connect the second end of the cable to the COM port of the terminal. The COM port connector on the Monitor cable is a 9 pin D-type plug.
2. Run a terminal emulation program (e.g., ProComm or Windows HyperTerminal) using the following setup:

<i>Baud rate</i>	9600
<i>Data bits</i>	8
<i>Stop bits</i>	1
<i>Parity</i>	None
<i>Flow Control</i>	Xon/Xoff
<i>Connector</i>	Available Com Port

3. Press **Enter**. The *Select Access Level* menu appears. Select the access level according to your authorized access level. You will be requested to enter your password. After entering the correct password press enter. The main menu appears (refer to Figure 3-1).

```

BreezeACCESS/SU-I-1D
Official Release Version - 2.5.3
Release Date: Tue Jul 18 21:12:54 2000
Main Menu
=====
1 - Info Screens
2 - Unit Control
3 - Basic Configuration
4 - Site Survey
5 - Advanced Configuration
BreezeACCESS >>>
    
```

Unit Type

Software Version No.

Unit Name

**Figure 3-1. Main Menu**

The appearance of the displayed *Main Menu* varies in accordance with the access level.

- For users with read only access rights, only the *Info Screens* option is displayed. Users with this access level cannot access the *Unit Control*, *Basic Configuration*, *Site Survey* and *Advanced Configuration* menus.
- For users with Installer access rights, the first four menu items (*Info Screens*, *Unit Control*, *Basic Configuration* and *Site Survey*) are displayed. Users with this access level cannot access the *Advanced Configuration* menu.
- For users with Administrator access rights, the full *Main Menu* will be displayed. These users can access all the menu items.

4. Operate the monitor program as follows:
  - Type an option number to open/activate the option. You may need to press the Enter key in some cases.
  - Press the Esc key to exit a menu or an option.
  - You can log-out and exit the monitor program at any time by simultaneously pressing the **Ctrl** and **X** keys.
  - Reset the unit after making configuration changes for the new values to take effect.
  - You can view the current parameters' configuration by selecting 1 in the Main Menu to Access the Info Screens menu, and then selecting 2 in the Info Screens menu to view the Basic Configuration parameters.

## **3.2 Configuration Parameters**

The following system parameters must be configured for each specific installation:

- *ESSID*
- *IP Address*
- *Subnet Mask*
- *Default Gateway Address*
- *Frequency Offset*
- *Hopping Band*
- *Flexible sub-bands Definition (if Flexible Hopping was selected in the Hopping Band menu)*
- *Transmit Antenna*

---

**Note:** You must select *Reset Unit* in the *Unit Control* menu for the changes to take effect.

---

Subscriber Units should be configured after the applicable Access Unit is operational. When configuring Subscriber Units, the first parameter that should be configured is the *ESSID*. Otherwise the unit will not successfully synchronize with the Access Unit and will continuously reset itself, thus interfering with the configuration process.

1. From the *main menu*, type **3** to access the *Basic Configuration* menu.

```

BreezeACCESS/SU-I-1D
Official Release Version - 2.5.3
Release Date: Tue Jul 18 21:12:54 2000

Basic Configuration
=====
1 - IP Address
2 - Subnet Mask
3 - Default Gateway Address
4 - ESSID
5 - Maximum Data Rate
6 - Frequency Offset
H - Hopping Band
F - Flexible sub-bands Definition
G - Transmit Antenna
P - Power Level
S - Show Basic Configuration
BreezeACCESS >>>

```

**Figure 3-2. Basic Configuration Menu**

2. From the *Basic Configuration* menu, type **4** to access the *ESSID* selection screen. Enter the required ESSID.
3. Type **1** to access the *IP Address* selection screen. Enter the required IP address.
4. Type **2** to access the *Subnet Mask* selection screen. Enter the required subnet mask.
5. Type **3** to access the *Default Gateway Address* selection screen. Enter the required default gateway address.
6. Type **6** to access the *Frequency Offset* selection screen. Enter the required *Frequency Offset*

7. Type **H** to access the *Hopping Band* selection screen. Enter the required hopping band.
8. If Flexible Hopping was selected in the Hopping Band selection menu, type **F** to access the Flexible sub-bands Definition menu. Use the Add/Delete sub-bands screens to define the required frequencies. See Appendix C for a list of the standard frequencies as a function of the allocated channel(s).
9. Type **G** to access the *Transmit Antenna* selection screen. Enter the required selection (0 - use two antennas, 1 - use antenna #1, 2 - use antenna #2). For SU-I units with two integral antennas, select 0 - use two antennas.

### **3.3 Reset Unit**

1. From the *main menu*, type **2** to access the *Unit Control* menu.
2. Type **1** to access the *Reset Unit* menu. Type **1** to reset the unit so that new configuration settings are applied.

---

**Note:** *Should you make any mistakes during configuration or encounter any problems associated with system configuration parameters, you may configure the unit back to the factory defaults, as follows:*

*Type 2 in the Unit Control menu to access the Set Factory Defaults menu. Type in 2 (Set Factory defaults-Full) to load the default values. Reset the unit for the factory defaults values to take effect.*

---

## 4. ALIGNING THE ANTENNA

Omni and low gain antennas do not require alignment due to their wide radiation pattern. High gain antennas have a narrow beamwidth, necessitating an alignment procedure in order to optimize the link.

For Subscriber Units with directional antenna(s), you can either use the LED indicators on the front panel of the unit or view the Received Signal Strength Indication (RSSI) on the monitor. In most installations, alignment using the LEDs is sufficient. The RSSI reading can be used when finer alignment is required.

---

***Note:** Antenna alignment of the Subscriber Unit is possible only after the Access Unit you wish to associate with is operational and the ESSID was properly configured.*

---

### 4.1 Aligning the Antenna Using the LEDs

1. Synchronize the units by aligning the antenna manually to point to the base station until the WLNK indicator LED on the front panel of the unit illuminates.
2. Rotate the antenna left and/or right until you reach the point of signal quality reading on the quality (QLT) LEDs. The higher the number of illuminated LEDs the better is the quality of the link. Make sure that at all times, the front of the antenna faces the general direction of the Access Unit.
3. For proper operation, at least one (L) LED should be illuminated. If this is not possible, improve the link quality by placing the antenna at a higher point or in a different location.
4. After the antenna is optimally aligned, tighten the U-bolts (or metal band) to secure the antenna to the pole.

## 4.2 Aligning the Antenna Using the Site Survey Menu

1. Start the Monitor program as described in Section 3.1.
2. From the *main menu*, type 4 to access the *Site Survey* menu. Type 4 to start the *Continuous RSSI Display*. Each line in the display includes the number of frames that were received since the last measurement (total Rx) and the average RSSI for these frames.
3. Rotate the antenna left and/or right until you reach the point of maximum RSSI reading. Make sure that at all times, the front of the antenna faces the general direction of the Base Station.
4. For proper operation, the RSSI reading should be at least 52 units. When the maximum reading is less than 52 units, try to improve it by placing the antenna at a higher point or in a different location. For best performance it is recommended that the RSSI be higher than 76.
5. Press the **Esc** key to stop the test.
6. Tighten the U-bolts (or metal band) over the antenna to secure it to the pole.



## 5. MAXIMUM DATA RATE CONFIGURATION

1. If the average RSSI reading using the Average RSSI Continuous Display is lower than 76, the default data rate of 3 Mbps is too high and the data rate of the unit should be configured accordingly:
2. From the *main menu*, type **3** to access the *Basic Configuration* menu. Type **5** to access the *Maximum Data Rate* menu.
  - i) Type **3** (3Mbps) if the RSSI reading is higher than 76 units.
  - ii) Type **2** (2Mbps) if the RSSI reading is between 66 to 76 units.
  - iii) Type **1** (1Mbps) if the RSSI reading is lower than 66 units.
3. Reset the unit for the new configuration to become effective.

## 6. VERIFYING PROPER OPERATION

After completing the installation, and after connecting the unit to the AC mains, the system starts operation. To verify proper operation, view the LED panel located on the front panel of the unit. Table 6-1 lists the various LED states.

**Table 6-1. SU-I LEDs**

Name	Description	Functionality	
PWR	Power supply	On – After successful power up Off – Power off	
WLNK	Wireless Link Activity	Blinking – Receiving packets from the wireless link Off – no reception of packets from the wireless link	
ETH	Ethernet activity	Blinking – Reception of data from Ethernet LAN Off – No reception of data from Ethernet LAN	
QLT	Quality of received RF signal	H ○ M ○ L ○  H ○ M ○ L ●	Very low quality reception or not synchronized with Access Unit, less than -81 dBm  Low quality reception (usually enabling 1Mbps traffic) from -81 to -77 dBm  Medium quality reception (usually enabling 2 Mbps traffic) from -77 to -65 dBm  High quality reception (usually enabling 3 Mbps traffic) greater than -65 dBm
		H ● M ● L ●	

### 6.1 Verifying Data Connectivity

From the user's PC or from a portable PC connected to the unit, Ping the unit or try to connect it to the Internet.

## 7. SPECIFICATIONS

### 7.1 Radio

Frequency	band A (MMDSa):2.500 – 2.600GHz band B (MMDSb):2.596 – 2.686GHz	
Radio Access Method	FH-CDMA or TDMA	
Operation Mode	Time Duplex Division	
Channel Bandwidth	2 MHz	
Output Power (at antenna port)	19dBm typical.	
Sensitivity (dBm at antenna port, BER 1E10 <sup>-6</sup> )	1Mbps 2Mbps 3Mbps	-89 -82 -73
Data Rate	3Mbps max	
Modulation	Multilevel GFSK	

### 7.2 Data Communication

Standard Compliance	IEEE 802.3 CSMA/CD
---------------------	--------------------

### **7.3 Configuration and Management**

Local Management	Via MON port, Monitor program using terminal emulation
Remote Management	SNMP, Telnet, TFTP
Remote Management Access	From Wired LAN, Wireless Link
SNMP Agents	MIB II, Bridge MIB, Private MIBs
Accounting	RADIUS compatible client
Security	Authentication and filtering
Software upgrade	TFTP download

### **7.4 Interfaces**

RF (Antenna)	2 x SMA jacks
Ethernet	10Base-T (RJ-45)
Monitor	3-pin low profile
Power	DC socket for a power transformer

### **7.5 Electrical**

External power Supply	100-250 VAC, 50-60 Hz, 0.5 A
Input voltage	5VDC

### **7.6 Mechanical**

Without antenna and power supply	13cm x 8.6cm x 3cm
----------------------------------	--------------------

### **7.7 Environmental**

Operating Temperature	0°C to 40°C
Operating Humidity	5%-95% non condensing

## **7.8 Standards Compliance, General**

EMC	FCC part 15, FCC part 21
Safety	UL 1950
Environmental	GR - 63 - CORE (Bellcore)

## APPENDIX A. AL 1 Lightning Arrestor

The AL 1 Lightning Arrestor is used to protect transmitters and receivers from transients originating from lightning or EMP.

The AL 1 is gas tube-based and is not radioactive. The gas discharge tube can sustain several transients if the time period between transients is sufficient to allow the tube to cool down.

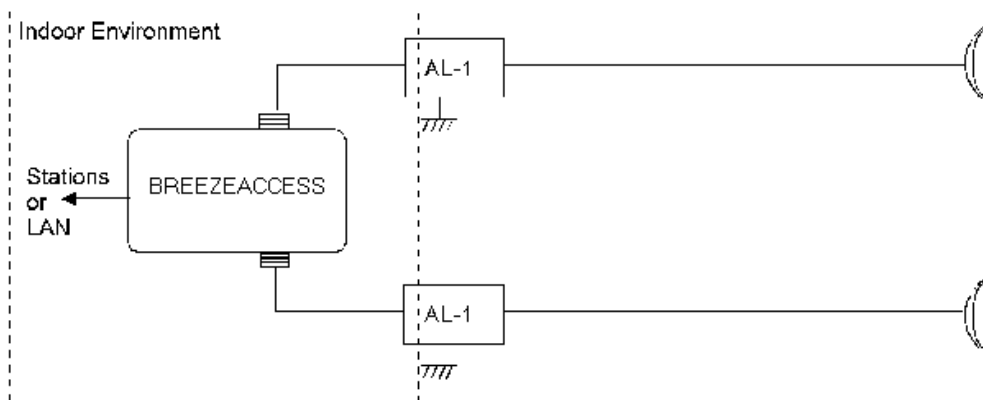

**Figure A-1. AL-1 Connection Block Diagram**

One of the female-type N connectors is mounted directly through a hole in the shelter wall and held in place with a lockwasher and nut.

## AL 1 Lightning Arrestor Specifications

Turn on voltage	75V
Insertion loss	0.3dB typical
DC path from input to output	existing
Operating Temperature	-55° C to +70° C
Dimensions	67.5mm x 25mm x 25mm (2.7" x 1" x 1")
Connectors	<ul style="list-style-type: none"><li>• Antenna Port: N-type, Female</li><li>• Equipment Port: N-type, Female</li></ul>
Operating Environment	Indoor/Outdoor
Grounding	One of the female-type N connectors is mounted directly through a hole in the shelter wall and held in place with a lockwasher and nut.

---

*Note: All specifications are subject to change without notice.*

---

## APPENDIX B. USING TELNET

Use the following procedure to connect to BreezeACCESS units via a Telnet session.

1. Connect the PC to the Ethernet port of the unit (or the hub to which the unit is connected) using a straight Ethernet cable. If you connect the PC directly to a unit that is normally connected to a hub, use a crossed Ethernet cable. You may also connect the PC to any Ethernet port on the network and communicate with the unit to be managed via the wired or wireless media.
2. Make sure that the IP parameters of the PC are configured to enable connectivity with the unit.
3. Run a Telnet application and use the IP address of the unit to be managed as the Host Name.
4. Set Port to *Telnet* (this is the default).
5. Set Terminal Type to *VT100* (this is the default).
6. Enter the Service Provider password.
7. When the password is recognized, the following message is displayed:

You have entered.
8. Press **Enter**, the Breeze ACCESS Monitor is displayed on the screen.

To exit the Telnet session, choose *Disconnect* from the *Connect* menu. (The session is terminated automatically, after a specific time of inactivity determined by the Log-out Timer).



## APPENDIX C. MMDS CHANNELS AND FREQUENCIES

Channel Name	Frequency Band (MHz)	Low Frequency (MHz)		High Frequency (MHz)	
		Actual	Value in Add/Delete Sub-bands menu	Actual	Value in Add/Delete Sub-bands menu
A1	2500 - 2506	2501.5	2501	2504.5	2504
B1	2506 - 2512	2507.5	2507	2510.5	2510
A2	2512 - 2518	2513.5	2513	2516.5	2516
B2	2518 - 2524	2519.5	2519	2522.5	2522
A3	2524 - 2530	2525.5	2525	2528.5	2528
B3	2530 - 2536	2531.5	2531	2534.5	2534
A4	2536 - 2542	2537.5	2537	2540.5	2540
B4	2542 - 2548	2543.5	2543	2546.5	2546
C1	2548 - 2554	2549.5	2549	2552.5	2552
D1	2554 - 2560	2555.5	2555	2558.5	2558
C2	2560 - 2566	2561.5	2561	2564.5	2564
D2	2566 - 2572	2567.5	2567	2570.5	2570
C3	2572 - 2578	2573.5	2573	2576.5	2576
D3	2578 - 2584	2579.5	2579	2582.5	2582
C4	2584 - 2590	2585.5	2585	2588.5	2588

Channel Name	Frequency Band (MHz)	Low Frequency (MHz)		High Frequency (MHz)	
		Actual	Value in Add/Delete Sub-bands menu	Actual	Value in Add/Delete Sub-bands menu
D4	2590 - 2596	2591.5	2591	2594.5	2594
E1	2596 - 2602	2597.5	2597	2600.5	2600
F1	2602 - 2608	2603.5	2603	2606.5	2606
E2	2608 - 2614	2609.5	2609	2612.5	2612
F2	2614 - 2620	2615.5	2615	2618.5	2618
E3	2620 - 2626	2621.5	2621	2624.5	2624
F3	2626 - 2632	2627.5	2627	2630.5	2630
E4	2632 - 2638	2633.5	2633	2636.5	2636
F4	2638 - 2644	2639.5	2639	2642.5	2642
G1	2644 - 2650	2645.5	2645	2648.5	2648
H1	2650 - 2656	2651.5	2651	2654.5	2654
G2	2656 - 2662	2657.5	2657	2660.5	2660
H2	2662 - 2668	2663.5	2663	2666.5	2666
G3	2668 - 2674	2669.5	2669	2672.5	2672
H3	2674 - 2680	2675.5	2675	2678.5	2678
G4	2680 - 2686	2681.5	2681	2684.5	2684