

AMANO®

MJR-8000 Series

Computerized Time Recorder

Programming / User Guide

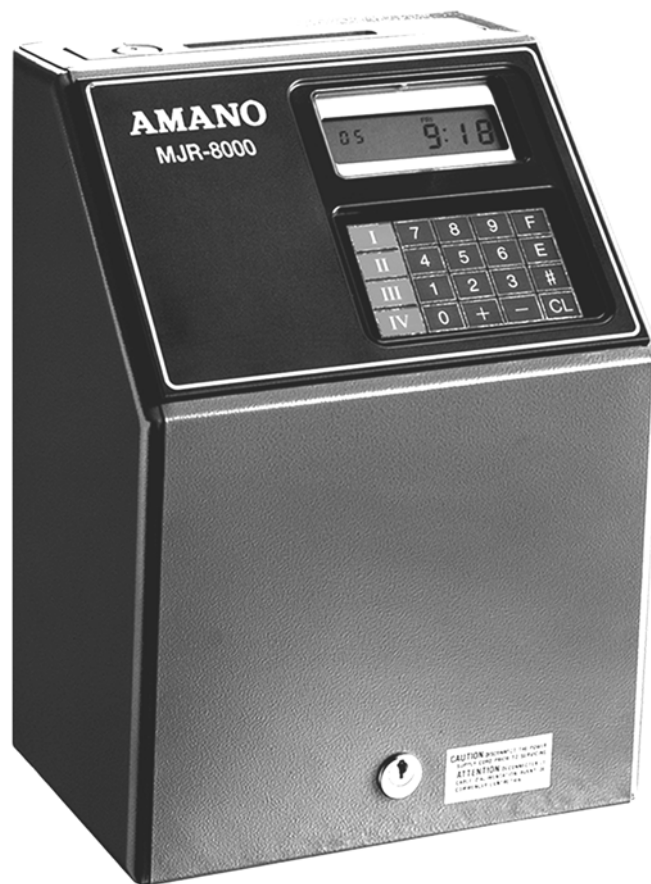

Amano Cincinnati Inc. reserves the right to make equipment changes and improvements that may not be reflected in this document. Portions of this document may have been updated to include the latest hardware or firmware version, if applicable.

We recommend that this document be read in its entirety before any attempt is made to operate the equipment.

Proprietary Notice

This document contains proprietary information and such information may not be reproduced in whole or in part without written permission from:

Amano Cincinnati, Inc.
140 Harrison Avenue
Roseland, NJ, 07068

For more information about Amano's complete line of products, visit our web site at:

<http://www.amano.com>

TABLE OF CONTENTS

1. GENERAL

Introduction	1
Hardware Diagram	2
Specifications	3

2. INSTALLATION

Removing Clock From Box	5
Activating Batteries:	
a) Ni-Cd Battery Backup	6
b) Full Power Reserve Kit (Optional)	7
Signal Kit (Optional)	8
Mounting	13

3. GETTING STARTED

Keypad	15
Display Screen	16
Sample Cards:	
a) Employee Time Card	17
b) Authorization Cards	18
c) Report Card	19
d) Program Check Card	20

4. PROGRAMMING GUIDE

Overview - Entering in Data	P	1
Program Setup Procedure	P	3
Initialization	P	4
Password Setup	P	5
Clock and Calendar Programming Area	P	6
Time Card Number Assignment Configuration Programming Area.....	P	12
General Programming Area	P	13
Signal Programming Area	P	15
Calculation Rules Programming Area	P	18
Program Print Out	P	28

5. USER GUIDE

User Setup Procedures For:		
a) Traditional Assignment Method	U	1
b) Employee Master File Using The Same Card Number	U	2
c) Employee Master File Using New Card Number	U	5
Overview - Instructions for Employee Use	U	9
Department Number File Maintenance	U	10
Employee Master File Maintenance	U	12
Time Card Number Assignment	U	15
Time Card Name Printing	U	18

TABLE OF CONTENTS

5. USER GUIDE (CONTINUED)

Data Correction	U	21
Individual Time Card Summary	U	24
Reports:		
Accumulated Period Hours	U	25
Accumulated Period Dollars	U	26
Yesterday's Hours	U	28
Yesterday's Dollars	U	28
Today's Hours	U	29
Today's Dollars	U	29
Approaching Overtime	U	30
Punched IN	U	31
Punched OUT	U	32
Password Maintenance	U	33

6. MAINTENANCE

Diagnostics:		
a) Memory Test	U	34
b) Printer Test	U	36
c) Sensor Test	U	37
Replacing Ribbon Cartridge	U	38

7. ERROR CODES

MJR-8000 Error Code List / Solution	U	40
---	---	----

8. APPENDIX

ASCII Table Character Translation	U	44
---	---	----

* INTRODUCTION

CONGRATULATIONS! You have just purchased one of the most popular computerized time recorders available today.

The new and improved MJR-8000 offers more features and flexibility to provide you with even more savings and more control over your labor costs.

The MJR-8000 automatically calculates and accumulates hours worked based on your company's payroll policies and separates them into regular and overtime pay categories. It also offers many sophisticated features to simplify payroll preparation such as: Lock Out, Revision, Red Print and Grace Zones; Flexible Rounding Rules; Unpaid and Paid Breaks; Time Card Name Printing; and more!

In addition, easy-to-read management reports are available in hours or dollars giving you more accurate labor information in less time.

ABOUT THIS MANUAL

This manual was designed to provide you with complete instructions on programming and operating the MJR-8000

The installation, setup procedures, and programming are usually performed by your Amano Representative. This information is included for your reference.

The Program Manual contains a chart to easily guide you through initial setup.

The User's Manual also contains a chart to easily guide you through the many features of this clock.

It is recommended that you follow the steps in each chart in the order presented to take full advantage of the many capabilities the MJR-8000 offers.

If you have any questions, please feel free to contact your local AMANO representative for additional assistance.

GENERAL

* HARDWARE DIAGRAM

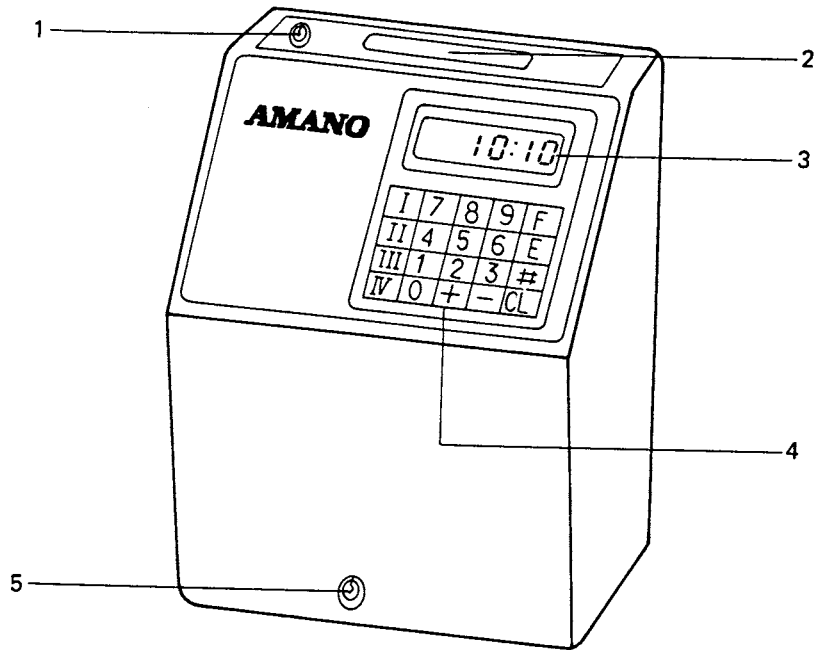

1. Key Switch : a) "NORMAL" mode for IN/OUT punches.
(without key)
b) "FUNCTION" mode for programming and
operations (with key in keyhole and
turned to the right).
2. Card Pocket : Automatically transports time cards and
report cards.
3. Display : Displays date, day of week, time, AM/PM,
program addresses, etc.
4. Keypad : Numeric membrane keypad.
5. Key Switch Lock : Unlock/Lock cover case.

*** SPECIFICATIONS**

Power Supply	:	AC 120V \pm 10%
Ambient Temperature:	:	+14 ^o F - +104 ^o F
Humidity	:	20% - 90% (No condensation)
Power Consumption	:	Normal 25VA, Maximum 75VA
Dimensions	:	13 1/2"H x 9 1/2"W x 8"D
Weight	:	17.25 pounds
Employee Capacity	:	250 employees
Ribbon	:	Two color cartridge
Ni-CD Battery Backup	:	Retains data for up to 72 hours
Mounting	:	Wall or table mount
Full Power Reserve	:	(Optional) 4 hours or 200 punches
Signals	:	(Optional) Rings up to 30 signals

**** This page intentionally left blank ****

* REMOVING CLOCK FROM BOX

1. CONTENTS: 1 MJR-8000
 1 Program / User's Manual
 1 Quick Reference Guide
 2 #700 keys

2. REMOVE PACKING MATERIALS:
 - a) Insert key into keyhole on the front of the cover case and turn to the right to unlock. Remove cover case.
 - b) Remove packing materials on ribbon cartridge.
 - c) Replace cover case and lock.

INSTALLATION

*** ACTIVATING BATTERIES - NI-Cd BATTERY BACKUP**

1. Ni-Cd BATTERY BACKUP:

When connected will enable the clock to store all data for up to 72 hours.

- a) Unlock cover case and remove.
- b) Plug in battery connector (3P, blue and red wires) to CN-2, located inside the frame (lower right) on the main printed circuit board (AMJM-1).
- c) Replace cover case and lock.

* ACTIVATING BATTERIES - FULL POWER RESERVE KIT (OPTIONAL)

1. Check the contents of the full power reserve kit:
 - a) Ni-Cd battery assembly - DC 12V
 - b) printed circuit board
 - c) 2 Self-tapping screws
2. Unplug AC power cord.
3. Unlock and remove cover case from clock.
4. Install the Ni-Cd battery assembly at the front of the main body. Attach the battery mounting plate into (A) and (B) on the left frame of the main body with the self-tapping screws.
5. Install printed circuit board on the right frame of the main body into holes (C) and (D).

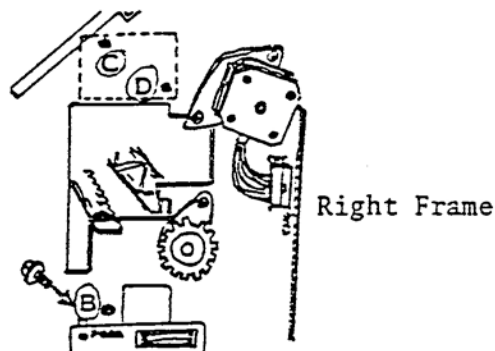
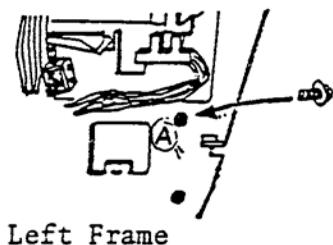

6. Plug in 4P connector from the Ni-Cd battery assembly into CN11 on the printed circuit board.
7. Plug in 3P connector from the printed circuit board into CN5 on the main printed circuit board by passing it under the stepping motor.

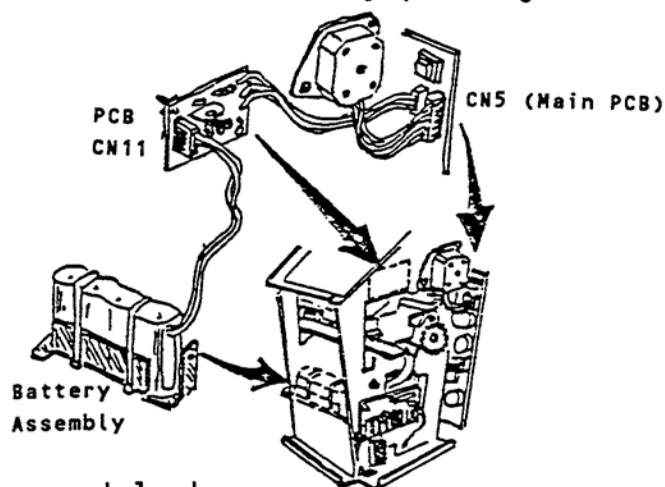

8. Replace cover case and lock.
9. Plug into AC power outlet and charge the battery for 10 hours. You will be able to use the clock immediately while the battery is charging.

INSTALLATION

* SIGNAL KIT (OPTIONAL)

1. Check the contents of the signal kit:
 - a) Signal printed circuit board (Part# IR-632092)
 - b) Locking washer (Part# WIB-4006)
 - c) Self-tapping screw (Part# UTJ-4006)
 - d) Cable holder (Part# EHL-200610)
2. Unplug AC power cord.
3. Unlock and remove cover case from clock.
4. Install signal printed circuit board assembly on the left frame of the main body. Insert printed circuit board support into the holes (A) and (B) of the left frame. (see diagram)
5. Attach the green grounding wire from the terminal block of the signal printed circuit board to hole (C) of the left frame with the locking washer and self-tapping screw. (see diagram)
6. Thread the brown and red twisted wire behind the transformer, over the Ni-Cd battery, through the large hole (on the right side of the frame under the black ribbon cable) and plug in 5P connector into CN6 on main printed circuit board.

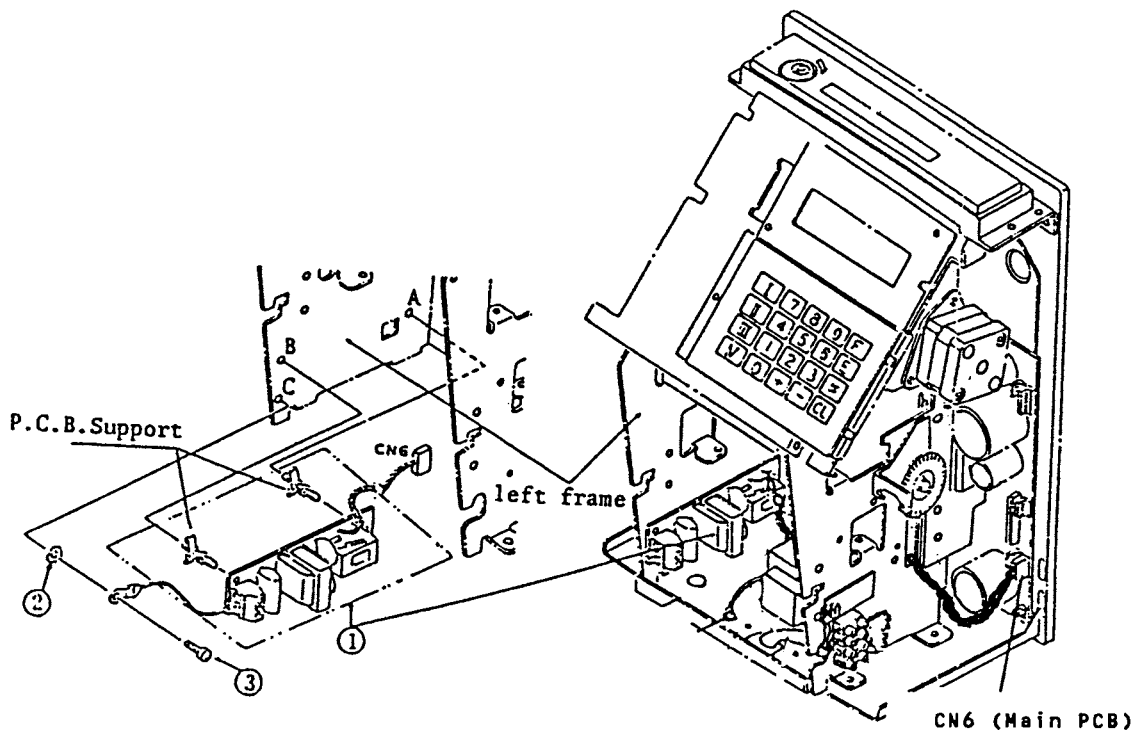

* SIGNAL KIT (OPTIONAL)

7A. For AC 120V Power Supply:

- 1) Connect external signal (bell) wire to the terminal block on the signal PCB and to the AC 120V power supply.
- 2) Connect a jumper wire from the AC 120V power supply to the terminal block on the signal PCB.
- 3) Connect a surge absorber (ESA-100010 - not included) to the terminal block on the signal PCB.

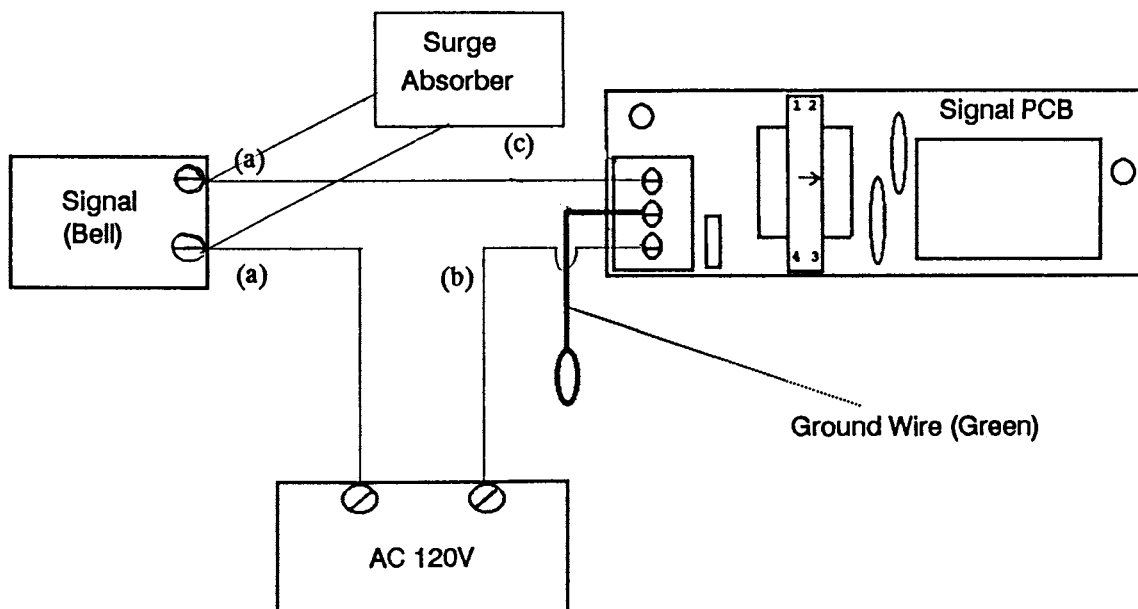

7B. When finished, replace cover case and lock.

7C. Test signal by following the program instructions on page [P 15] of the program manual.

INSTALLATION

* SIGNAL KIT (OPTIONAL)

8A. For DC 24V Power Supply:

- 1) Connect external signal (bell) wire to the terminal block on the signal PCB and to the DC side of the transformer.
- 2) Connect a jumper wire from the DC side of the transformer to the terminal block on the signal PCB.
- 3) Connect two wires from the AC side of the transformer to the AC 120V power supply.
- 4) Connect a surge absorber (ESA-100010 - not included) to the terminal block on the signal PCB.

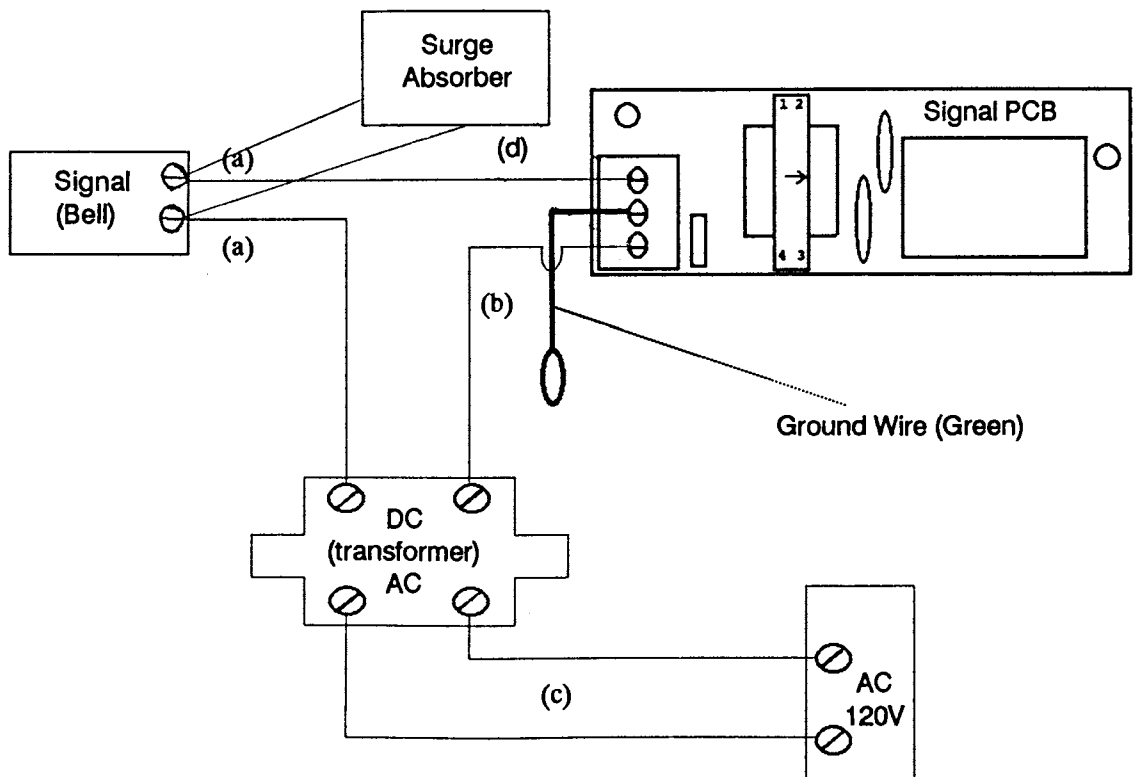

8B. When finished, replace cover case and lock.

8C. Test signal by following the program instructions on page [P 15] of the program manual.

** This page intentionally left blank **

** This page intentionally left blank **

* MOUNTING

<< Avoid direct sunlight and dusty areas when mounting >>

1. WALL MOUNT:

- a) Unlock and remove cover case.
- b) Remove the two screws that affix the back plate to the body and push the back plate down.
- c) Knock out the three holes on the back plate. (There are two on the bottom on either side and one in the middle towards the top).
- d) Drive one wood screw partially into the wall and hang the back plate by the center hole.
- e) After making sure that the back plate is level, firmly secure it to the wall with the remaining screws.
- f) Install the body on the back plate. Fit the hanger lips of the body frame into the grooves of the back plate. Then install the two screws to firmly secure the body onto the back plate.

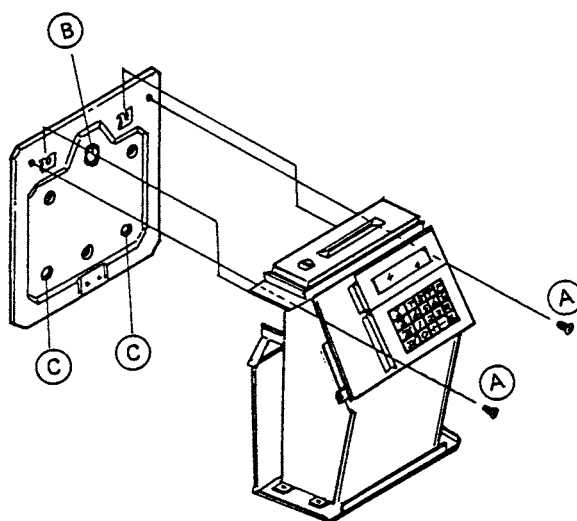

2. TABLE MOUNT:

- a) No installation necessary.

**** This page intentionally left blank ****

* **KEYPAD**

There are 10 numeric keys and 10 additional keys on the membrane keypad.

I	7	8	9	F
II	4	5	6	E
III	1	2	3	#
IV	0	+	-	CL

- [0] - [9] = Numeric keys - Used to access program addresses, input of data and user access codes.
- [#] = Number (Pound) key - Used to advance to next step within an address and for paid break when activated.
- [E] = Enter key - Registers data entered from keypad (temporarily) and advances to next program address.
- [I] = Save key - Saves program data, employee master file data and department data.
- [CL] = Clear key - Clears data incorrectly entered from keypad.
- [F] = Function or 'Find' key - Locate a specific address number by pressing 'F', entering in the address number, followed by 'E'.
- [+], [-] = Plus, Minus keys - Used for adding or subtracting hours when making data corrections.
- [IV] = Roman numeral four key - Used for generating the sensor test after the memory test is completed in maintenance.
- [II], [III] = Not Used

GETTING STARTED

* DISPLAY SCREEN

The display screen will show the current date, day and time when in the "NORMAL" mode.

Example: For April 30, 1991 at 5:28 pm

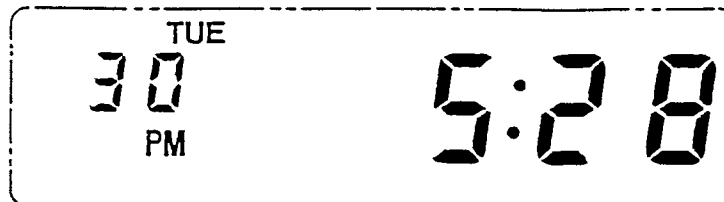

When in the "FUNCTION" mode the display screen may display access code numbers, address and step numbers, program data, etc. based on what has been selected.

Example 1: After pressing '1 0 E', the program address 000 step 1, displays the entered data for the year 1991.

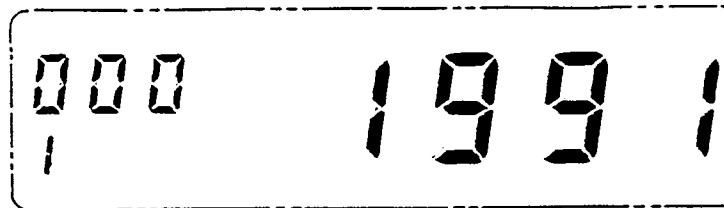

Example 2: After pressing '4 4 E' (for the accumulated period dollars report), '----' is displayed to show that the password was entered.

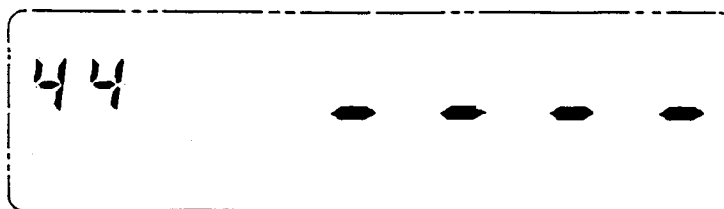

GETTING STARTED

* SAMPLE CARDS -- AUTHORIZATION CARDS

The Revision / Lock Out Authorization Card is used to override programmed revision AND lock out zones.

The Lock Out Authorization Card is used to override programmed lock out zones ONLY.

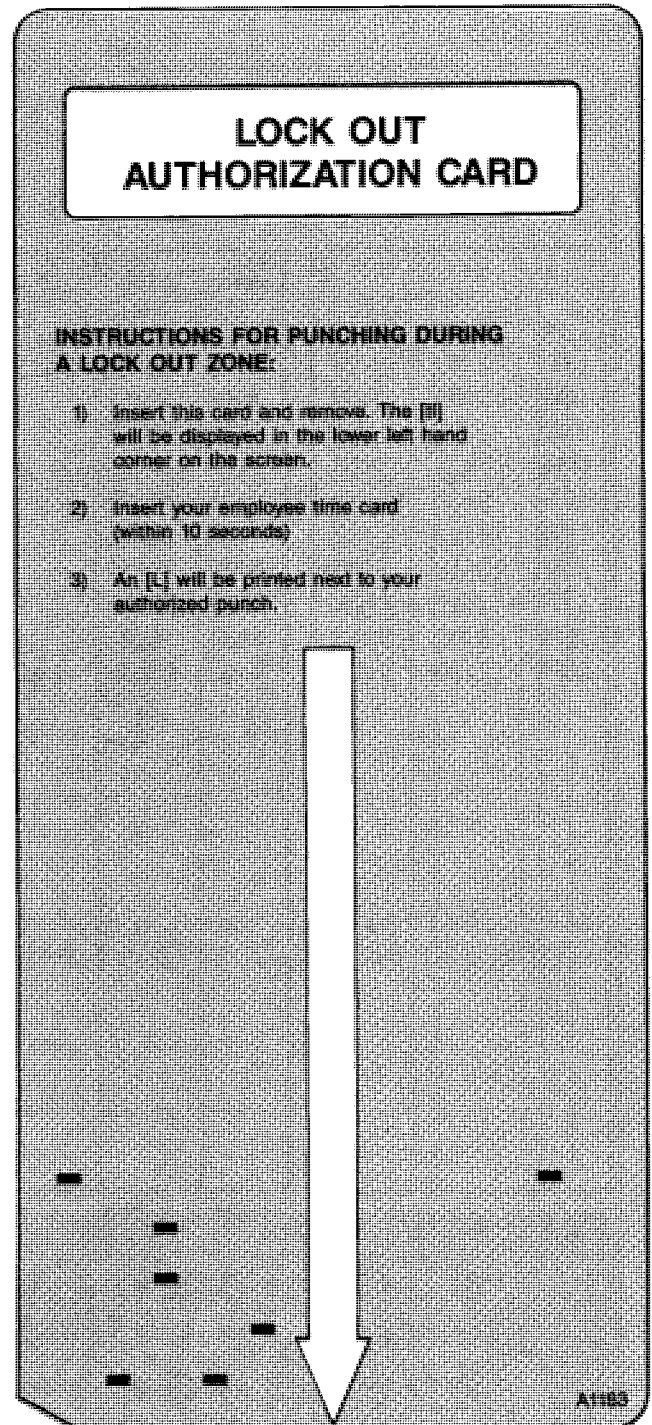
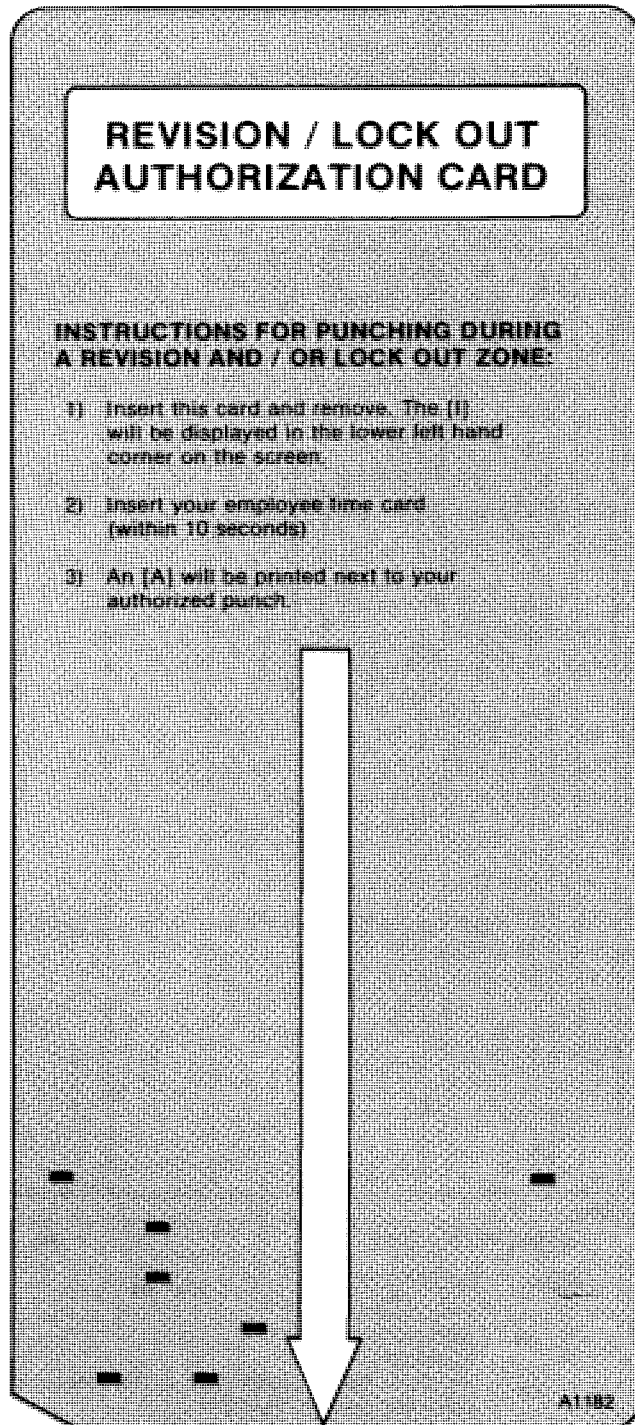

* SAMPLE CARDS -- REPORT CARD

The report card is used for all reports and lists that are generated by using the available User Access Codes.

MJR SERIES REPORT CARD				
ACC.PERIOD HOURS REPORT (CURRENT)				
9/21/91 17:02 PAGE- 0				
TOTAL	REG.	OT-A.	OT-B.	
DEPT. 000300				
* BIANCA, MARY	001	4335566778		
007 26:32	26:00	0:32	0:00	
STEVEN, MIKE	004	0532190887		
010 32:45	32:30	0:15	0:00	
SPENCER, MAGGIE	248	3449328820		
029 34:00	31:00	3:00	0:00	
93:17	89:30	3:47	0:00	
DEPT. 000350				
TAYLOR, ANNA	003	3422177890		
009 30:00	30:00	0:00	0:00	
WILLIAMS, TERRI	007	0000008770		
013 26:30	26:30	0:00	0:00	
GARRET, JANET	008	3214556678		
014 24:30	24:30	0:00	0:00	
* JERREL, ERIC	020	1423644212		
026 17:18	16:45	0:33	0:00	
CRANE, NANCY	249	4988730217		
027 19:30	19:30	0:00	0:00	
117:48	117:15	0:33	0:00	
DEPT. 000400				
SMITH, MARTY	000	1435566667		
006 22:45	22:45	0:00	0:00	

MJR SERIES REPORT CARD				
APPROACHING OT.REPORT HOURS > 30:59				
9/21/91 17:03 PAGE- 0				
NAME	FILE#.	ID #.	HOURS	
DEPT. 000300				
STEVEN, MIKE	004	0532190887	32:45	
SPENCER, MAGGIE	248	3449328820	34:00	
SUB TOTAL			66:45	
DEPT. 000350				
SUB TOTAL			0:00	
DEPT. 000400				
SUB TOTAL			0:00	
DEPT. 000450				
* BECKER, SAM	150	5332819543	41:00	
SUB TOTAL			41:00	
DEPT. 000500				
* STEWART, JANICE	200	4323516349	41:00	
SUB TOTAL			41:00	
DEPT. 000550				
PURCELL, JIM	189	2399183756	40:00	

GETTING STARTED

* SAMPLE CARDS -- PROGRAM CHECK CARD

The program check card is used when performing the program print out. It is recommended to print at least three copies of the program after initial setup and whenever program changes are made. One copy should be stored inside the cover case of the clock, another copy should be given to the Amano Representative and another copy should be attached to this manual.

MJR SERIES PROGRAM CHECK CARD					
PROGRAM VER 1.0 9/21/91 17:16 PAGE- 0					
1	407	1027			
2	0	0	0		
3	1	0	0		
4	101	218	527	704	
8	902	1014	1128	1225	
12	0	0	0	0	
16	0	0	0	0	
20	5				
21		135	730	5	755
23		12345	800	12345	1200
25		12345	1300	12345	1655
27		12345	1700	0	0
29		0	0	0	0
31		0	0	0	0
33		0	0	0	0
35		0	0	0	0
37		0	0	0	0
39		0	0	0	0
41		0	0	0	0
43		0	0	0	0
45		0	0	0	0
47		0	0	0	0
49		0	0	0	0
51	0				
52	1	0	0	0	
100	3	7	0		
101	800	0			
102	4000	0			
103	0				

MJR SERIES PROGRAM CHECK CARD					
PROGRAM VER 1.0 9/21/91 17:17 PAGE- 1					
104	15	150	200		
105	6	7	0		
106	0	100			
107	600	30			
108	1000	30			
109	0	15	5		
110	15	8			
111	15	8			
112	300	1	5		
113	1				
114	1	808	829	2	1130 1159
116	3	1401	1429	2	1645 1659
118	0	0	0	0	0 0
120	1	730	800	2	1700 1730
122	4	800	810	0	0 0
124	0	0	0	0	0 0
126	0	0	0	0	0 0
128	0	0	0	0	0 0
130	0	0	0	0	0 0
132	0	0	0	0	0 0
134	0	0	0	0	0 0
136	0	0	0	0	0 0
138	0	0	0	0	0 0
140	0	0	0	0	0 0
142	0	0	0	0	0 0
144	0	0	0	0	0 0
146	0	0	0	0	0 0
148	0	0	0	0	0 0

MJR-8000 PROGRAM MANUAL 

*** OVERVIEW - ENTERING IN DATA**

1. There are six different programming areas in this section. Each area uses address numbers and step numbers. The step number is the area within an address number where specific data is entered to tell the clock HOW to operate. The address number tells the MJR-8000 WHERE this specific data is to be stored in memory.
2. There are different types of specific data that can be entered in a step number. These types appear in the Program Codes and Descriptions column of each program chart.
 - a) Code Numbers - Enter a code number that corresponds to the given value. (Example: 0 = 1200 where 0 is the code number which is entered into the step number)
 - b) Dates - A year, or a month and date is entered into the step number. (Example: 1991 for the year, 1225 for the month and date)
 - c) Hours - ALL hours must be entered in military hours (0000 - 2359)
 - d) Minutes - ALL minutes must be entered in regular minutes (00 - 60) regardless of how the clock is set up to DISPLAY and PRINT the hours.
EXCEPTION: If the clock is set up to print in hundredth hours then you must enter hundredth hours when making data corrections.
3. Each program area has an address number that will appear in the upper left hand corner of the display with the step number directly beneath it.
 - a) If an address has only 1 step, enter the data followed by the 'E' key to advance to the next address number.

Example: In address 051 you enter in clock number 0. This address contains only 1 step.

Address No.	Step No.	Data	Advance/Save
051	1	0	E

- b) If an address has more than 1 step, enter the data for the first step and press the '#' key to move to the second step within that same address. Enter the data for the second step and then press the '#' key to move to the third step within that same address. Enter the data for the third step and then press the 'E' key to advance to the next address while temporarily saving the data.

PROGRAMMING GUIDE

* OVERVIEW - ENTERING IN DATA

Example: In address 000 you enter in the year (1991), month and date (0430 for April 30th), and the time in military hours (1728 is equivalent to 5:28PM). This address contains 3 steps.

Address No.	Step No.	Data	Advance/Save
000	1	1991	#
000	2	0430	#
000	3	1728	E

*** PROGRAM SETUP PROCEDURE**

This part of the manual contains a chart to guide you through the Program Setup Procedure.

For each step, refer to the page number for detailed instructions on WHAT TO DO.

PROGRAM SETUP CHART			
STEP	WHAT TO DO	USER ACCESS CODE	PAGE
1	Initialize the ENTIRE clock	32 E 64 E	P 4
2	Password Setup	11 E	P 5, U 33
3	Raw Data Collection Programming	14 E	P 6
4	Clock and Calendar Programming	10 E	P 6
5	Time Card Number Assignment Configuration Programming	13 E	P 8
6	General Programming	20 E	P 13
7	Signal Programming (OPTIONAL - Signal Kit must be installed to send signal)	21 E	P 15
8	Calculation Rules Programming	22 E	P 18
9	Program Print-Out	23 E	P 28

PROGRAMMING GUIDE

* INITIALIZATION

Before you begin using the MJR-8000 you need to clear the memory by initializing the clock. This procedure should be performed by your Amano Representative.

1. Plug into AC power outlet. The printer section will move back and forth several times and the display may show an error code 8-80. To reset this error code 8-80 press the 'CL' key on the keypad.
2. Put the key in the key switch located on the top of the clock next to the card pocket.
3. Turn the key to the right to access the "FUNCTION" mode.
4. There are three initialization codes available for clearing the memory in the clock. You can clear ALL the memory (program and employee data), Program Data ONLY, and Employee Data ONLY.
 - a) CLEAR ALL MEMORY: This operation should be performed by your Amano representative before you begin using the clock for the first time.
 - Press '32 E 64 E' followed by the special password number 'XXXX' and then press 'E'.
 - The display screen will go blank.
 - Turn the key to the left to return to "NORMAL" mode.
 - b) CLEAR PROGRAM DATA ONLY: This operation will CLEAR ALL program data. It should be performed only when it is necessary to reprogram the clock without having to clear the employee master files.
 - Press '31 E 99 E' followed by the user password number 'XXXX' and then press 'E'.
 - The display screen will go blank.
 - Turn the key to the left to return to "NORMAL" mode.
 - c) CLEAR EMPLOYEE DATA ONLY: This operation will CLEAR ALL employee master file data. It should be performed only when employee master files need to be reentered without having to clear out the program data.
 - Press '30 E 88 E' followed by the user password number 'XXXX' and then press 'E'.
 - The display screen will go blank.
 - Turn the key to the left to return to "NORMAL" mode.

*** PASSWORD SETUP**

The MJR-8000 provides you with password protection for certain Program and User Access Codes to offer you added security.

After the initialization procedure '32 E 64 E XXXX E' the password is automatically set to '0000'. It is not required for you to change your password unless you require that extra security.

The areas that require a password are:

- Initialization:
 - ALL memory (program and employee data) (32 E 64 E)
 - ALL employee data (30 E 88 E)
 - ALL program data (31E 99 E)
- Time Card Number Assignment Programming Area (13 E)
- Time Card Number Assignment (82 E and 83 E)
- Lists with Pay Rates:
 - Employee Lists (64 E and 65 E)
- Reports with Pay Rates or Dollar Amounts:
 - Individual Time Card Summary with Pay Rates (5 E and 6 E)
 - Accumulated Dollar\$ Reports (44 E, 45 E, 46 E and 47 E)
 - Yesterday's Dollar\$ Report (49 E)
 - Today's Dollar\$ Report (51 E)

IF YOU WISH TO CHANGE THE EXISTING PASSWORD, REFER TO PAGE [U 33] in the MJR-8000 User's Manual for detailed instructions.

PROGRAMMING GUIDE

*** RAW DATA COLLECTION PROGRAMMING AREA**

- To Enter Program Area - Turn The Key and Press **1 4 E**
- Enter the password **X X X X E**

PROGRAM ADDRESS NO.	SAMPLE PROGRAM DATA	PROGRAM CODES AND DESCRIPTIONS
14 1	1 #	Choice to Enable Raw Data Feature: 0 = Disable raw data feature (OFF) 1 = <u>Enable</u> raw data feature (ON)
2	0 #	Clock Control Code: Valid Hole Punch Numbers on Time Card are 0 - 9. [The hole punched in the fourth row (from the bottom) of the time card should match the number set up here for all time cards used for this clock.]
3	0 #	Choice to Print Accumulated Hours: 0 = <u>Do not</u> print accumulated hours 1 = <u>Print</u> accumulated hours
4	1 #	Cost Center Number Entry / Printing: 0 = <u>Do not</u> activate cost center number 1 = <u>Activate and do not</u> print cost center number 2 = <u>Activate and print</u> cost center number
5	1 E	Function Code Entry: 0 = <u>Do not</u> activate function keys (I, II, III, IV) 1 = <u>Activate</u> function keys (I, II, III, IV)

AFTER THE 'E' KEY IS PRESSED THE DISPLAY WILL GO BLANK AND THE DATA WILL BE AUTOMATICALLY SAVED IN MEMORY.

- Turn key back to "NORMAL" mode

*** CLOCK AND CALENDAR PROGRAMMING AREA**

- To Enter Program Area - Turn The Key and Press **1 0 E**

PROGRAM ADDRESS NO.	SAMPLE PROGRAM DATA	PROGRAM CODES AND DESCRIPTIONS
000 1	1 9 9 1 #	Calendar Year (YYYY)
2	4 3 0 #	Month and Date (MMDD)
3	1 7 2 8 E	Hour and Minute (24 hour format - HHMM)

THE DISPLAY WILL GO BLANK AND THE DATA WILL BE AUTOMATICALLY SAVED IN MEMORY.

- Turn key back to "NORMAL" mode

** This page intentionally left blank **

PROGRAMMING GUIDE

* TIME CARD NUMBER ASSIGNMENT CONFIGURATION PROGRAMMING AREA

The MJR-8000 gives you three methods to choose from for employee time card number assignment. The method you choose will determine which features and reports are available.

FILE NUMBERS AND CARD NUMBERS:

Each MJR-8000 has a capacity of 250 employees. This means that there are 250 files numbered from 000 to 249 within the clock to store employee information. This information consists of the employee number, employee name, department number, pay rate and all accumulated hours worked.

Time cards are available in different RANGES of card numbers. Examples of standard boxes of cards are numbered 000-049, 000-099, 000-199, 000-249 and 000-999. Other ranges of card numbers are also available.

When an employee punches IN or OUT, the time clock reads the punched holes on the bottom of the card (the time card number) and then searches for the file number to which the time card number is assigned. The accumulated hours will then get stored into the memory area of that file number.

The assignment type will determine HOW the card numbers will be assigned to the file number.

ASSIGNMENT TYPES:

- 1) Traditional Assignment - (Refer to User Setup Chart on page U1 of the User Manual)

The traditional assignment method allows you to issue time cards to your employees right from the box WITHOUT having to assign the time cards first. Each pay period simply write the employee's name on the time card, place the card in the card rack and you're ready to go.

In this area you will be required to enter the starting and ending range of time card numbers (the same as the numbers on the time card box). File number 000 will correspond to the card number programmed in the STARTING CARD NUMBER field in this area. The ENDING CARD NUMBER is ignored for this type of method. The remaining file numbers will be sequentially assigned until all 250 file numbers are assigned.

- ** NOTES:
- a) Since the employee master file is not being used there are no names, departments or pay rates in the clock which limits the reports that can be generated. The following reports can be generated:
 - * Individual Time Card Summary [Current (3 E) and Previous (4 E) Pay Periods]

*** TIME CARD NUMBER ASSIGNMENT CONFIGURATION PROGRAMMING AREA**

- * Accumulated Period Hours [Current (40 E) and Previous (41 E) Pay Periods]
- * Yesterday's Hours (48 E)
- * Today's Hours (50 E)
- * Approaching Overtime (52 E)
- * Punched IN (53 E)
- * Punched OUT (55 E)

When an attempt is made to generate any other report an error code (2-14) will be displayed.

- b) If a semimonthly or monthly pay period is set up, employees should be issued the same time card number each pay period. The weekly overtime hours will carry-over onto the new time card and ensure correct calculation.
- c) If the clock is initialized after setting up the assignment area 13E, you will have to reprogram 13E to reassign time card numbers to the file numbers.

2) Employee Master File Using The Same Card Numbers - (Refer to User Setup Charts on pages U2 - U4 of the User Manual)

This method gives you the flexibility to utilize ALL of the features of the MJR-8000 without having to worry about assigning time cards every pay period. (Initial set up is required)

In this area you will be required to enter the starting and ending range of time card numbers (the same as the numbers on the time card box). The initial set up requires you to automatically assign time card numbers for ALL employees (User Access Code = 83 E). The STARTING CARD NUMBER entered during 83 E must be within the starting and ending range card numbers programmed in this area.

FOR EXAMPLE:

- * There are 45 employees
- * The box of time cards is numbered 000 - 049 so the starting and ending card number range programmed in this area is 000 - 049.
- * When accessing 83 E to automatically assign time card numbers, the starting card range number entered is 000.
- * The clock will assign the cards as follows:

File Number	=	Card Number
000	=	000
001	=	001
⋮		⋮
045	=	045

(Card numbers 046 - 049 will not be used)
 Card numbers 000 - 045 will be used each pay period and correspond to the file numbers above.

PROGRAMMING GUIDE

* TIME CARD NUMBER ASSIGNMENT CONFIGURATION PROGRAMMING AREA

- ** NOTES:
- Since the employee master file IS USED, you will be required to set up departments and employees before assigning the time cards. (User Access Codes = 72 E and 61 E).
 - When new employees are added during the pay period they will have to be individually assigned. (User Access Codes = 61 E and 84 E)
 - During the time card number assignment (83 E), if the ending card number is reached during sequential incrementing, the next assignment will scroll back to the starting card number.
 - ALL of the features and reports are available by using this method.

3) Employee Master File Using New Card Numbers - (Refer to User Setup Charts on page U5 - U8 in the User Manual)

This method gives you the flexibility to utilize ALL of the features of the MJR-8000. This method allows you to maximize your time card usage. By assigning time card numbers each pay period, you will be able to use each and every time card number without waste.

In this area you will be required to enter the starting and ending range of time card numbers (the same as the numbers on the time card box). In addition to the initial set up, it is required to automatically assign time card numbers EACH pay period for ALL employees (User Access Code = 82 E or 83 E). The STARTING CARD NUMBER entered during 82 E or 83 E must be within the starting and ending range card numbers programmed in this area. If the ending card number is reached during sequential incrementing, the next assignment will scroll back to the starting card number.
FOR EXAMPLE:

- * Card assignment for four consecutive weeks with 75 employees.
- * The box of time cards is 000 - 999 so the starting and ending card range numbers programmed in this area are 000 and 999.
- * When accessing 83 E 88 E (for the current pay period) to automatically assign time card numbers, the starting card range number entered is 000.
- * The clock will assign the cards as follows:

File Number	=	Card Number
000	=	000
001	=	001
⋮		⋮
075	=	075
- * When accessing 83 E 99 E (for the next pay period) to automatically assign time card numbers, the starting card number is 076.

*** TIME CARD NUMBER ASSIGNMENT CONFIGURATION PROGRAMMING AREA**

* The clock will assign the cards as follows:

File Number	=	Card Number
000	=	076
001	=	077
⋮		⋮
075	=	151

* When this week becomes the current pay period, access 83 E 99 E (for the next pay period) to automatically assign time card numbers. The starting card number is 152.

* The clock will assign the cards as follows:

File Number	=	Card Number
000	=	152
001	=	153
⋮		⋮
075	=	226

* When this week becomes the current pay period, access 83 E 99 E (for the next pay period) to automatically assign time card numbers. The starting card number is 227.

* The clock will assign the cards as follows:

File Number	=	Card Number
000	=	227
001	=	228
⋮		⋮
075	=	301

- ** NOTES:
- a) Since the employee master file IS USED, you will be required to set up departments and employees before assigning the time cards. (User Access Codes = 72 E and 61 E).
 - b) When new employees are added during the pay period they will have to be individually assigned. (User Access Codes = 61 E and 84 E)
 - c) During the time card number assignment (83 E), if the ending card number is reached during sequential incrementing, the next assignment will scroll back to the starting card number.
 - d) Duplicate time card numbers should not be used for 3 consecutive pay periods. If time card number 000 is assigned to FILE number 000 for the current pay period, then the time card number 000 should NOT be assigned at all for the next or previous pay period.
 - e) ALL of the features and reports are available.

PROGRAMMING GUIDE

* TIME CARD NUMBER ASSIGNMENT CONFIGURATION PROGRAMMING AREA

- To Enter Program Area - Turn The Key and Press 1 3 E
- Type in your valid password number and press 'E'.

PROGRAM ADDRESS NO.		SAMPLE PROGRAM DATA					PROGRAM CODES AND DESCRIPTIONS
13	1				2	#	Assignment Type: 0 = Traditional Assignment 1 = Employee Master Files with The Same Time Card Numbers 2 = Employee Master Files with New Time Card Numbers
	2		0	0	0	#	Starting Time Card Number Range (Enter a valid 3 digit number, 000 - 999)
	3		2	4	9	E	Ending Time Card Number Range (Enter a valid 3 digit number, 000 - 999)

THE DISPLAY WILL GO BLANK AND THE DATA WILL BE AUTOMATICALLY SAVED IN MEMORY.

- Turn key back to "NORMAL" mode

*** GENERAL PROGRAMMING AREA**

- To Enter Program Area - Turn The Key and Press 2 0 E

PROGRAM ADDRESS NO.	SAMPLE PROGRAM DATA	PROGRAM CODES AND DESCRIPTIONS
001	1	4 0 7 #
		Daylight Saving Time Start Date - Enter the date for the 1ST Sunday in April. (Spring ahead one hour)
---	2	1 0 2 7 E
		Daylight Saving Time End Date - Enter the date for the LAST Sunday in October. (Fall behind one hour)
002	1	<< The clock will automatically skip this address >>
003	1	1 #
		Printing of hours for IN/OUT times AND Clock Display Format: 0 = 0-23 hour format (military hours) 1 = 1-12 for AM, <u>1-12</u> for PM hours
---	2	0 #
		Printing of IN/OUT times & accumulated hours: 0 = Regular minutes for both (:00-:59) 1 = Regular min. for IN/OUT times (:00-:59) 100th of hour for accumulated (.00-.98) 2 = 100th of hour for IN/OUT times (.00-.98) Regular minutes for accumulated (:00-:59) 3 = 100th of hour for both (.00-.98)
---	3	0 E
		Printing of day of the week: 0 = English days (MO, TU, WE, TH, FR, SA, SU) 1 = Day numbers (D1, D2, D3, D4, D5, D6, D7) 2 = French days (LU, MA, ME, JE, VE, SA, DI) 3 = Spanish days (LU, MA, MI, JU, VI, SA, DO)
004	1	1 0 1 E
		Month and Date of Public Holiday 1 (MMDD)
005	1	2 1 8 E
		Month and Date of Public Holiday 2 (MMDD)
006	1	5 2 7 E
		Month and Date of Public Holiday 3 (MMDD)
007	1	7 0 4 E
		Month and Date of Public Holiday 4 (MMDD)
008	1	9 0 2 E
		Month and Date of Public Holiday 5 (MMDD)
009	1	1 0 1 4 E
		Month and Date of Public Holiday 6 (MMDD)
010	1	1 1 2 8 E
		Month and Date of Public Holiday 7 (MMDD)
011	1	1 2 2 5 E
		Month and Date of Public Holiday 8 (MMDD)
012	1	0 E
		Month and Date of Public Holiday 9 (MMDD)

PROGRAMMING GUIDE

* GENERAL PROGRAMMING AREA

PROGRAM ADDRESS NO.	SAMPLE PROGRAM DATA	PROGRAM CODES AND DESCRIPTIONS
013 1		Month and Date of Public Holiday 10 (MMDD)
014 1		Month and Date of Public Holiday 11 (MMDD)
015 1		Month and Date of Public Holiday 12 (MMDD)
016 1		Month and Date of Public Holiday 13 (MMDD)
017 1		Month and Date of Public Holiday 14 (MMDD)
018 1		Month and Date of Public Holiday 15 (MMDD)
019 1		Month and Date of Public Holiday 16 (MMDD)

Holidays worked can be sorted into regular hours or overtime hours by selecting the appropriate pay category code located in the Calculation Programming Area (22E) address 105.

IMPORTANT: UPON COMPLETION OF THE GENERAL PROGRAMMING AREA, BE SURE TO PRESS THE I KEY TO SAVE THE DATA INTO MEMORY.

- Turn key back to "NORMAL" mode

* SIGNAL PROGRAMMING AREA (OPTIONAL)

- To Enter Program Area - Turn The Key and Press 2 1 E

PROGRAM ADDRESS NO.	SAMPLE PROGRAM DATA					PROGRAM CODES AND DESCRIPTIONS
020	1			5	E	Signal duration in seconds (0 - 15)
021	1	1	3	5	#	Day code number: 1 = Monday 2 = Tuesday 3 = Wednesday 4 = Thursday 5 = Friday 6 = Saturday 7 = Sunday 8 = Monday thru Friday 9 = Monday thru Sunday - Enter the number for the day(s) the signal applies. (Example: If Mon, Wed, Fri press 1,3,5) ** When code number is selected the day(s) will appear on the display.
	2	7	3	0	E	Signal time (HHMM)
022	1			5	#	Day code number (1 - 9)
	2	7	5	5	E	Signal time (HHMM)
023	1			8	#	Day code number (1 - 9)
	2	8	0	0	E	Signal time (HHMM)
024	1			8	#	Day code number (1 - 9)
	2	1	2	0	E	Signal time (HHMM)
025	1			8	#	Day code number (1 - 9)
	2	1	3	0	E	Signal time (HHMM)
026	1			8	#	Day code number (1 - 9)
	2	1	6	5	E	Signal time (HHMM)
027	1			8	#	Day code number (1 - 9)
	2	1	7	0	E	Signal time (HHMM)

PROGRAMMING GUIDE

* SIGNAL PROGRAMMING AREA (OPTIONAL)

PROGRAM ADDRESS NO.	SAMPLE PROGRAM DATA				PROGRAM CODES AND DESCRIPTIONS
028	1			0 #	Day code number (1 - 9)
	2			0 E	Signal time (HHMM)
029	1			0 #	Day code number (1 - 9)
	2			0 E	Signal time (HHMM)
030	1			0 #	Day code number (1 - 9)
	2			0 E	Signal time (HHMM)
031	1			0 #	Day code number (1 - 9)
	2			0 E	Signal time (HHMM)
032	1			0 #	Day code number (1 - 9)
	2			0 E	Signal time (HHMM)
033	1			0 #	Day code number (1 - 9)
	2			0 E	Signal time (HHMM)
034	1			0 #	Day code number (1 - 9)
	2			0 E	Signal time (HHMM)
035	1			0 #	Day code number (1 - 9)
	2			0 E	Signal time (HHMM)
036	1			0 #	Day code number (1 - 9)
	2			0 E	Signal time (HHMM)
037	1			0 #	Day code number (1 - 9)
	2			0 E	Signal time (HHMM)
038	1			0 #	Day code number (1 - 9)
	2			0 E	Signal time (HHMM)
039	1			0 #	Day code number (1 - 9)
	2			0 E	Signal time (HHMM)

*** SIGNAL PROGRAMMING AREA (OPTIONAL)**

PROGRAM ADDRESS NO.	SAMPLE PROGRAM DATA				PROGRAM CODES AND DESCRIPTIONS
040	1			0 #	Day code number (1 - 9)
	2			0 E	Signal time (HHMM)
041	1			0 #	Day code number (1 - 9)
	2			0 E	Signal time (HHMM)
042	1			0 #	Day code number (1 - 9)
	2			0 E	Signal time (HHMM)
043	1			0 #	Day code number (1 - 9)
	2			0 E	Signal time (HHMM)
044	1			0 #	Day code number (1 - 9)
	2			0 E	Signal time (HHMM)
045	1			0 #	Day code number (1 - 9)
	2			0 E	Signal time (HHMM)
046	1			0 #	Day code number (1 - 9)
	2			0 E	Signal time (HHMM)
047	1			0 #	Day code number (1 - 9)
	2			0 E	Signal time (HHMM)
048	1			0 #	Day code number (1 - 9)
	2			0 E	Signal time (HHMM)
049	1			0 #	Day code number (1 - 9)
	2			0 E	Signal time (HHMM)
050	1			0 #	Day code number (1 - 9)
	2			0 E	Signal time (HHMM)

IMPORTANT: UPON COMPLETION OF THE SIGNAL PROGRAMMING AREA, BE SURE TO PRESS THE I KEY TO SAVE THE DATA INTO MEMORY.

- Turn key back to "NORMAL" mode

PROGRAMMING GUIDE

* CALCULATION RULES PROGRAMMING AREA

- To Enter Program Area - Turn The Key and Press 2 2 E

PROGRAM ADDRESS NO.	SAMPLE PROGRAM DATA			PROGRAM CODES AND DESCRIPTIONS
100 1			3 #	Pay period code number: 0 = Weekly (Front side of card only) 1 = Weekly - Using both sides of time card (Programmed week is the front side) 2 = Weekly - Using both sides of time card (Programmed week is the back side) 3 = Bi-Weekly (Pay period ends next week) 4 = Bi-Weekly (Pay period ends this week) 5 = Semi-Monthly 6 = Monthly
----- 2			7 #	Pay ending day or date depends on pay period selected in previous address. <u>For Weekly or Bi-Weekly</u> pay period enter pay ending <u>DAY</u> code number: 1 = Monday 2 = Tuesday 3 = Wednesday 4 = Thursday 5 = Friday 6 = Saturday 7 = Sunday - For Weekly press E to move to next address (101). - For Bi-Weekly press # to move to next step (3). <u>For Semi-Monthly</u> pay period: - Enter the earlier of the 2 pay ending dates and press #. (The pay ending date is automatically calculated 15 days from the date that you enter in.) (Ex: If the pay period ends on the 10th and 25th, enter 1 0 #) <u>EXCEPTION:</u> If the pay period ends on the 15th and the end of the month always enter 3 1 #. This ensures proper calculation for shorter months. <u>For Monthly</u> pay period: - Enter the pay ending date and press #. (Ex: If the pay period ends at the end of the month, enter 3 1 #)

* CALCULATION RULES PROGRAMMING AREA

PROGRAM ADDRESS NO.	SAMPLE PROGRAM DATA					PROGRAM CODES AND DESCRIPTIONS
(cont'd) 3				0	E	<p>Overtime calculation period:</p> <p><u>For Bi-Weekly</u> pay period: 0 = Weekly overtime 1 = Bi-Weekly overtime (8/80)</p> <p><u>For Semi-Monthly or Monthly</u> pay periods: -Enter the work week ending day to be used for overtime calculation and press E: 1 = Monday 2 = Tuesday 3 = Wednesday 4 = Thursday 5 = Friday 6 = Saturday 7 = Sunday</p>
101 1		8	0	0	#	<p>Overtime Category A - (Daily Overtime) - Enter the amount of daily hours that must be worked before being sorted to overtime category A.</p>
---	2			0	E	<p>Overtime Category B - (Daily Overtime) - Enter the amount of daily hours that must be worked before being sorted to overtime category B.</p>
102 1		4	0	0	#	<p>Overtime Category A - (Weekly Overtime) - Enter the amount of weekly hours that must be worked before being sorted to overtime category A.</p>
---	2			0	E	<p>Overtime Category B - (Weekly Overtime) - Enter the amount of weekly hours that must be worked before being sorted to overtime category B.</p>
103 1				0	E	<p>Line skip after each IN/OUT pair 0 = Do not skip any lines 1 = Skip 1 line 2 = Skip 2 lines 3 = Skip 3 lines</p>
104 1			1	5	#	<p>Paid break time (Using "#" key before or after punching for break) (00-60 min) - If paid break is not used, enter 0. This will make "#" key inactive.</p>

PROGRAMMING GUIDE

*** CALCULATION RULES PROGRAMMING AREA**

PROGRAM ADDRESS NO.	SAMPLE PROGRAM DATA					PROGRAM CODES AND DESCRIPTIONS
(cont'd) 2		1	5	0	#	Pay rate multiplier for overtime category A. (Valid range is 0000-0255. Decimal point is assumed two places. Used to calculate dollar amounts on reports from pay rates in employee master file)

3		2	0	0	E	Pay rate multiplier for overtime category B. (Valid range is 0000-0255. Decimal point is assumed two places. Used to calculate dollar amounts on reports from pay rates in employee master file)
105						<p>Non-working day codes: 1 = Monday 2 = Tuesday 3 = Wednesday 4 = Thursday 5 = Friday 6 = Saturday 7 = Sunday</p>

1				6	#	First non-working day (Ex: Saturday)

2				7	#	Second non-working day (Ex: Sunday)

3				0	E	<p>Pay category code for hours worked on above non-working days AND public holidays.</p> <p><u>CODE</u> = <u>NON-WORK DAY</u> & <u>HOLIDAY</u> 0 = Overtime A & Overtime B 1 = Overtime A & Overtime A 2 = Overtime B & Overtime B 3 = Regular & Regular 4 = Regular & Overtime A 5 = Regular & Overtime B</p>
106 1				0	#	<p>Day change override code: 0 = Allows employees to work thru day change time up to <u>12 hours and 59 minutes</u> from the last IN punch.</p> <p>1 = Does not allow employees to work thru day change time. (OUT time crossing day change time will be considered a new day.)</p> <p>2 = Allows employees to work thru day change time up to <u>17 hours and 59 minutes</u> from the last IN punch.</p>

* CALCULATION RULES PROGRAMMING AREA

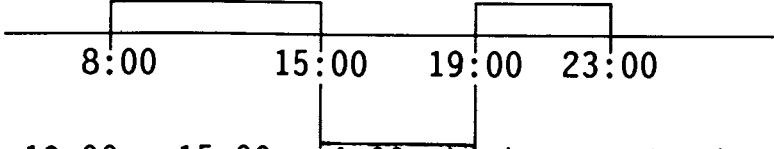
PROGRAM ADDRESS NO.	SAMPLE PROGRAM DATA					PROGRAM CODES AND DESCRIPTIONS
(cont'd) 2		1	0	0	E	Day change time (EX: 1 AM)
107						Automatic break deduction by number of daily hours worked - 1:
1		6	0	0	#	Daily worked hours
2			3	0	E	Amount of break time to be deducted
108						Automatic break deduction by number of daily hours worked - 2:
1	1	0	0	0	#	Daily worked hours
2			3	0	E	Amount of break time to be deducted
109	1			0	#	Day change mode: 0 = At or after midnight 1 = Before midnight
2			1	5	#	Break net rounding: Rounding unit (00-60 minutes)
3				5	E	Rounding forward break point (00-60 min.)
110	1		1	5	#	IN punch rounding: Rounding unit (00-60 minutes)
2				8	E	Rounding forward break point (00-60 min.)
111	1		1	5	#	OUT punch rounding: Rounding unit (00-60 minutes)
2				8	E	Rounding forward break point (00-60 min.)
112	1	3	0	0	#	Minimum off hours for split shift calculation - Enter the minimum off hours to separate calculations for different work shifts. EX1: 7 hrs REG 4 hrs REG  19:00 - 15:00 = 4:00 which exceeds the 3:00 programmed amount. The calculations are separated as if two different shifts were worked.

PROGRAMMING GUIDE

* CALCULATION RULES PROGRAMMING AREA

PROGRAM ADDRESS NO.	SAMPLE PROGRAM DATA					PROGRAM CODES AND DESCRIPTIONS
(cont'd)						EX2: 7 hrs REG + 1 hr REG + 3 hrs OT 8:00 15:00 17:00 23:00 17:00 - 15:00 = 2:00 which is less than 3:00 programmed amount. The calculations will be considered as if one shift was worked.

2				1	#	Lock out if previous day's OUT punch was missed: 0 = No lock out for today's 1st IN punch 1 = Lock out for today's 1st IN punch

3				5	E	Individual lock out (00-60 minutes) - (same as repeat punch protection)

THE FOLLOWING ADDRESSES 113 - 119 ARE FOR RED PRINT OR LOCK OUT ZONES

PROGRAM ADDRESS NO.	SAMPLE PROGRAM DATA					PROGRAM CODES AND DESCRIPTIONS
113	1				1 E	Selection for type of zone: 0 = Lock out zone only 1 = Red print zone only
The following <u>type of punch code numbers</u> apply for addresses 114 - 119: 0 = Not used 1 = 1st IN punch 2 = OUT punch 3 = IN punch (other than 1st IN)						
114	1				1 #	Type of punch code number (0 - 3)

	2		8	0	8 #	Start time of zone (HHMM)

	3		8	2	9 E	End time of zone (HHMM)
115	1				2 #	Type of punch code number (0 - 3)

	2	1	1	3	0 #	Start time of zone (HHMM)

	3	1	1	5	9 E	End time of zone (HHMM)

*** CALCULATION RULES PROGRAMMING AREA**

PROGRAM ADDRESS NO.	SAMPLE PROGRAM DATA					PROGRAM CODES AND DESCRIPTIONS
116	1			3	#	Type of punch code number (0 - 3)
	2	1	4	0	1 #	Start time of zone (HHMM)
	3	1	4	2	9 E	End time of zone (HHMM)
117	1			2	#	Type of punch code number (0 - 3)
	2	1	6	4	5 #	Start time of zone (HHMM)
	3	1	6	5	9 E	End time of zone (HHMM)
118	1			0	#	Type of punch code number (0 - 3)
	2			0	#	Start time of zone (HHMM)
	3			0	E	End time of zone (HHMM)
119	1			0	#	Type of punch code number (0 - 3)
	2			0	#	Start time of zone (HHMM)
	3			0	E	End time of zone (HHMM)

THE FOLLOWING ADDRESSES 120 - 149 ARE FOR REVISION, GRACE AND FIXED BREAK ZONES.

The following type of punch code numbers apply for addresses 120 - 149:

0 = Not used

REVISION ZONES : 1 = 1st IN punch {---->}
 2 = OUT punch {<----}
 3 = IN punch {---->}

GRACE ZONES : 4 = 1st IN punch {<----}
 5 = OUT punch {---->}
 6 = IN punch {<----}

FIXED BREAK ZONE : 7 = Unpaid zone (Cannot be programmed if automatic break deduction is programmed in addresses 107 and/or 108)

PROGRAMMING GUIDE

* CALCULATION RULES PROGRAMMING AREA

PROGRAM ADDRESS NO.		SAMPLE PROGRAM DATA					PROGRAM CODES AND DESCRIPTIONS
120	1				1	#	Type of punch code number (0 - 7)
	2		7	3	0	#	Start time of zone (HHMM)
	3		8	0	0	E	End time of zone (HHMM)
121	1				2	#	Type of punch code number (0 - 7)
	2	1	7	0	0	#	Start time of zone (HHMM)
	3	1	7	3	0	E	End time of zone (HHMM)
122	1				4	#	Type of punch code number (0 - 7)
	2		8	0	0	#	Start time of zone (HHMM)
	3		8	1	0	E	End time of zone (HHMM)
123	1				0	#	Type of punch code number (0 - 7)
	2				0	#	Start time of zone (HHMM)
	3				0	E	End time of zone (HHMM)
124	1				0	#	Type of punch code number (0 - 7)
	2				0	#	Start time of zone (HHMM)
	3				0	E	End time of zone (HHMM)
125	1				0	#	Type of punch code number (0 - 7)
	2				0	#	Start time of zone (HHMM)
	3				0	E	End time of zone (HHMM)
126	1				0	#	Type of punch code number (0 - 7)
	2				0	#	Start time of zone (HHMM)
	3				0	E	End time of zone (HHMM)
127	1				0	#	Type of punch code number (0 - 7)
	2				0	#	Start time of zone (HHMM)
	3				0	E	End time of zone (HHMM)

* CALCULATION RULES PROGRAMMING AREA

PROGRAM ADDRESS NO.	SAMPLE PROGRAM DATA	PROGRAM CODES AND DESCRIPTIONS
128	1	0 # Type of punch code number (0 - 7)
	2	0 # Start time of zone (HHMM)
	3	0 E End time of zone (HHMM)
129	1	0 # Type of punch code number (0 - 7)
	2	0 # Start time of zone (HHMM)
	3	0 E End time of zone (HHMM)
130	1	0 # Type of punch code number (0 - 7)
	2	0 # Start time of zone (HHMM)
	3	0 E End time of zone (HHMM)
131	1	0 # Type of punch code number (0 - 7)
	2	0 # Start time of zone (HHMM)
	3	0 E End time of zone (HHMM)
132	1	0 # Type of punch code number (0 - 7)
	2	0 # Start time of zone (HHMM)
	3	0 E End time of zone (HHMM)
133	1	0 # Type of punch code number (0 - 7)
	2	0 # Start time of zone (HHMM)
	3	0 E End time of zone (HHMM)
134	1	0 # Type of punch code number (0 - 7)
	2	0 # Start time of zone (HHMM)
	3	0 E End time of zone (HHMM)
135	1	0 # Type of punch code number (0 - 7)
	2	0 # Start time of zone (HHMM)
	3	0 E End time of zone (HHMM)

PROGRAMMING GUIDE

* CALCULATION RULES PROGRAMMING AREA

PROGRAM ADDRESS NO.	SAMPLE PROGRAM DATA					PROGRAM CODES AND DESCRIPTIONS
136	1			0	#	Type of punch code number (0 - 7)
	2			0	#	Start time of zone (HHMM)
	3			0	E	End time of zone (HHMM)
137	1			0	#	Type of punch code number (0 - 7)
	2			0	#	Start time of zone (HHMM)
	3			0	E	End time of zone (HHMM)
138	1			0	#	Type of punch code number (0 - 7)
	2			0	#	Start time of zone (HHMM)
	3			0	E	End time of zone (HHMM)
139	1			0	#	Type of punch code number (0 - 7)
	2			0	#	Start time of zone (HHMM)
	3			0	E	End time of zone (HHMM)
140	1			0	#	Type of punch code number (0 - 7)
	2			0	#	Start time of zone (HHMM)
	3			0	E	End time of zone (HHMM)
141	1			0	#	Type of punch code number (0 - 7)
	2			0	#	Start time of zone (HHMM)
	3			0	E	End time of zone (HHMM)
142	1			0	#	Type of punch code number (0 - 7)
	2			0	#	Start time of zone (HHMM)
	3			0	E	End time of zone (HHMM)
143	1			0	#	Type of punch code number (0 - 7)
	2			0	#	Start time of zone (HHMM)
	3			0	E	End time of zone (HHMM)

*** CALCULATION RULES PROGRAMMING AREA**

PROGRAM ADDRESS NO.	SAMPLE PROGRAM DATA					PROGRAM CODES AND DESCRIPTIONS
144	1			0	#	Type of punch code number (0 - 7)
	2			0	#	Start time of zone (HHMM)
	3			0	E	End time of zone (HHMM)
145	1			0	#	Type of punch code number (0 - 7)
	2			0	#	Start time of zone (HHMM)
	3			0	E	End time of zone (HHMM)
146	1			0	#	Type of punch code number (0 - 7)
	2			0	#	Start time of zone (HHMM)
	3			0	E	End time of zone (HHMM)
147	1			0	#	Type of punch code number (0 - 7)
	2			0	#	Start time of zone (HHMM)
	3			0	E	End time of zone (HHMM)
148	1			0	#	Type of punch code number (0 - 7)
	2			0	#	Start time of zone (HHMM)
	3			0	E	End time of zone (HHMM)
149	1			0	#	Type of punch code number (0 - 7)
	2			0	#	Start time of zone (HHMM)
	3			0	E	End time of zone (HHMM)

IMPORTANT: UPON COMPLETION OF THE CALCULATION RULES PROGRAMMING AREA, BE SURE TO PRESS THE I KEY TO SAVE THE DATA INTO MEMORY.

- Turn key back to "NORMAL" mode

PROGRAMMING GUIDE

*** PROGRAM PRINT OUT**

- Turn key to "FUNCTION" mode
- Press

2	3	E
---	---	---
- There are three pages available for printing (P-0, P-1 and P-2). The display will show P-0.

TO PRINT ALL PAGES (P-0, P-1 and P-2):

- Insert a PROGRAM CHECK CARD. When the first page (P-0) is finished printing the card will automatically be ejected. Remove the card and the display will show (P-1). Reinsert the card on the back side to print the second page. When the second page is finished printing the card will automatically be ejected. Remove the card and the display will show (P-2). Insert a new card. When the third page is finished printing the card will automatically be ejected. Remove the card when printing is finished.
- Turn key back to "NORMAL" mode

TO PRINT THE SECOND PAGE ONLY (P-1):

- Press 'E' to advance to P-1 on the display.
- Insert a PROGRAM CHECK CARD. When the second page (P-1) is finished printing the card will automatically be ejected. Remove the card when printing is finished.
- Turn key back to "NORMAL" mode

TO PRINT THE THIRD PAGE ONLY (P-2):

- Press 'E' to advance to P-2 on the display.
- Insert a PROGRAM CHECK CARD. When the third page (P-2) is finished printing the card will automatically be ejected. Remove the card when printing is finished.
- Turn key back to "NORMAL" mode

MJR-8000 USER MANUAL 

*** USER SETUP PROCEDURES FOR TRADITIONAL ASSIGNMENT METHOD**

The following chart guides you through the initial user setup and each subsequent pay period routine for the TRADITIONAL TIME CARD NUMBER ASSIGNMENT METHOD. (Programmed in 13 E -- refer to pages P8-P9, P12).

TRADITIONAL ASSIGNMENT METHOD USER INITIAL SETUP CHART AND PAY PERIOD ROUTINE			
STEP	WHAT TO DO	USER ACCESS CODE	PAGE
1	Remove time cards, write employees' names on cards and place in card rack.	-----	-----
	<p>The follow User Access Codes ARE AVAILABLE:</p> <ul style="list-style-type: none"> * Individual Time Card Summary <ul style="list-style-type: none"> - Current Pay Period - Previous Pay Period * Accumulated Period Hours Report <ul style="list-style-type: none"> - Current Pay Period - Previous Pay Period * Yesterday's Hours Report * Today's Hours Report * Approaching Overtime Report * Punched IN Report * Punched OUT Report * Data Corrections <ul style="list-style-type: none"> - Current Pay Period - Previous Pay Period * Maintenance <ul style="list-style-type: none"> - Memory Test - Printer Test - Sensor Test 	<ul style="list-style-type: none"> 3 E 4 E 40 E 41 E 48 E 50 E 52 E 53 E 55 E 1 E 2 E 90 E 91 E 92 E 	<ul style="list-style-type: none"> U 24 U 24 U 25 U 25 U 28 U 29 U 30 U 31 U 32 U21-U22 U22-U23 U 34 U 36 U 37

USER GUIDE

* USER SETUP PROCEDURES FOR EMPLOYEE MASTER FILE USING THE SAME CARD NUMBER

The following charts guide you through the initial user setup and each subsequent pay period routine for the EMPLOYEE MASTER FILE USING THE SAME CARD NUMBER ASSIGNMENT METHOD. (Programmed in 13 E - Refer to pages P9-P10, P12) For each step, refer to the page number for detailed instructions WHAT TO DO.

EMPLOYEE MASTER FILE USING THE SAME CARD NUMBER ASSIGNMENT METHOD USER INITIAL SETUP CHART

STEP	WHAT TO DO	USER ACCESS CODE	PAGE
1	ADD department file numbers	72 E	U 10
2	PRINT LIST of department file numbers on report card	73 E	U 10
3	ADD employee master files	61 E	U 12
4	PRINT LIST of employee master files on report card - AND / OR - PRINT LIST of employee master files with PAY RATES on report card	62 E 64 E	U 12 U 13
5	CURRENT PAY PERIOD: AUTOMATICALLY ASSIGN DIFFERENT time card numbers to ALL employee master files for the <u>current</u> pay period - AND / OR - NEXT PAY PERIOD: AUTOMATICALLY ASSIGN DIFFERENT time card numbers to ALL employee master files for the <u>next</u> pay period	83 E 88 E 83 E 99 E	U 15 U 16
6	PRINT LIST of assigned time card numbers on report card	85 E	U 17
7	CURRENT PAY PERIOD: PRINT employee name on <u>ONE</u> side of the time card - OR - PRINT employee name on <u>BOTH</u> sides of the time card (continued next page)	80 E 1 E 80 E 2 E	U 18 U18-U19

*** USER SETUP PROCEDURES FOR EMPLOYEE MASTER FILE USING THE SAME CARD NUMBER**

EMPLOYEE MASTER FILE USING THE SAME CARD NUMBER ASSIGNMENT METHOD USER INITIAL SETUP CHART			
STEP	WHAT TO DO	USER ACCESS CODE	PAGE
7	(continued from previous page) - AND / OR - NEXT PAY PERIOD: PRINT employee name on <u>ONE</u> side of the time card - OR - PRINT employee name on <u>BOTH</u> sides of the time card	81 E 1 E 81 E 2 E	U 19 U 20
8	Place ALL employee time cards in the time card racks and you're ready to begin.	-----	-----

EMPLOYEE MASTER FILE USING THE SAME CARD NUMBER ASSIGNMENT METHOD PAY PERIOD ROUTINE			
STEP	WHAT TO DO	USER ACCESS CODE	PAGE
1*	ADD any NEW department file numbers	72 E	U 10
2*	PRINT LIST of department file numbers on report card	73 E	U 10
3*	ADD any NEW employee master files	61 E	U 12
4*	PRINT LIST of employee master files on report card - AND / OR - PRINT LIST of employee master files with PAY RATES on report card (continued next page)	62 E 64 E	U 12 U 13

* These steps are only required if you are adding NEW information for the pay period.

USER GUIDE

* USER SETUP PROCEDURES FOR EMPLOYEE MASTER FILE USING THE SAME CARD NUMBER

EMPLOYEE MASTER FILE USING THE SAME CARD NUMBER ASSIGNMENT METHOD PAY PERIOD ROUTINE			
STEP	WHAT TO DO	USER ACCESS CODE	PAGE
5*	<p>(continued from previous page) For NEWLY added employees: CURRENT PAY PERIOD: ASSIGN SPECIFIC CARD NUMBER to an individual employee for the <u>current</u> pay period.</p> <p style="text-align: center;">- AND / OR -</p> <p>NEXT PAY PERIOD: ASSIGN SPECIFIC CARD NUMBER to an individual employee for the <u>next</u> pay period.</p>	84 E 88 E	U 16
		84 E 99 E	U16-U17
6*	PRINT LIST of assigned time card numbers on report card	85 E	U 17
7	<p>For ALL employees: CURRENT PAY PERIOD: PRINT employee name on <u>ONE</u> side of the time card</p> <p style="text-align: center;">- OR -</p> <p>PRINT employee name on <u>BOTH</u> sides of the time card</p> <p style="text-align: center;">- AND / OR -</p> <p>NEXT PAY PERIOD: PRINT employee name on <u>ONE</u> side of the time card</p> <p style="text-align: center;">- OR -</p> <p>PRINT employee name on <u>BOTH</u> sides of the time card</p>	80 E 1 E	U 18
		80 E 2 E	U18-U19
		81 E 1 E	U 19
		81 E 2 E	U 20
8	Place ALL employee time cards in the time card racks and you're ready to begin.	-----	-----

* These steps are only required if you are adding NEW information for the pay period.

* USER SETUP PROCEDURES FOR EMPLOYEE MASTER FILE USING NEW CARD NUMBER

The following charts guide you through the initial user setup and each subsequent pay period routine for the EMPLOYEE MASTER FILE USING NEW CARD NUMBER ASSIGNMENT METHOD. (Programmed in 13 E -- Refer to pages P10-P12) For each step, refer to the page number for detailed instructions WHAT TO DO.

EMPLOYEE MASTER FILE USING NEW CARD NUMBER ASSIGNMENT METHOD
USER INITIAL SETUP CHART

STEP	WHAT TO DO	USER ACCESS CODE	PAGE
1	ADD department file numbers	72 E	U 10
2	PRINT LIST of department file numbers on report card	73 E	U 10
3	ADD employee master files	61 E	U 12
4	PRINT LIST of employee master files on report card - AND / OR - PRINT LIST of employee master files with PAY RATES on report card	62 E 64 E	U 12 U 13
	5	CURRENT PAY PERIOD: AUTOMATICALLY ASSIGN DIFFERENT time card numbers to ALL employee master files for the <u>current</u> pay period - AND / OR - NEXT PAY PERIOD: AUTOMATICALLY ASSIGN DIFFERENT time card numbers to ALL employee master files for the <u>next</u> pay period	83 E 88 E U 15 83 E 99 E U 16
6	PRINT LIST of assigned time card numbers on report card	85 E	U 17
7	CURRENT PAY PERIOD: PRINT employee name on <u>ONE</u> side of the time card - OR - PRINT employee name on <u>BOTH</u> sides of the time card (continued next page)	80 E 1 E 80 E 2 E	U 18 U18-U19

USER GUIDE

* USER SETUP PROCEDURES FOR EMPLOYEE MASTER FILE USING NEW CARD NUMBER

EMPLOYEE MASTER FILE USING NEW CARD NUMBER ASSIGNMENT METHOD USER INITIAL SETUP CHART			
STEP	WHAT TO DO	USER ACCESS CODE	PAGE
7	(continued from previous page) - AND / OR - NEXT PAY PERIOD: PRINT employee name on <u>ONE</u> side of the time card - OR - PRINT employee name on <u>BOTH</u> sides of the time card	81 E 1 E 81 E 2 E	U 19 U 20
8	Place ALL employee time cards in the time card racks and you're ready to begin.	-----	-----

EMPLOYEE MASTER FILE USING NEW CARD NUMBER ASSIGNMENT METHOD PAY PERIOD ROUTINE			
STEP	WHAT TO DO	USER ACCESS CODE	PAGE
1*	ADD any NEW department file numbers	72 E	U 10
2*	PRINT LIST of department file numbers on report card	73 E	U 10
3*	ADD any NEW employee master files	61 E	U 12
4*	PRINT LIST of employee master files on report card - AND / OR - PRINT LIST of employee master files with PAY RATES on report card (continued next page)	62 E 64 E	U 12 U 13

* These steps are only required if you are adding NEW information for the pay period.

* USER SETUP PROCEDURES FOR EMPLOYEE MASTER FILE USING NEW CARD NUMBER

EMPLOYEE MASTER FILE USING NEW CARD NUMBER ASSIGNMENT METHOD PAY PERIOD ROUTINE			
STEP	WHAT TO DO	USER ACCESS CODE	PAGE
5	<p>(continued from previous page) For ALL employees EVERY pay period: CURRENT PAY PERIOD: AUTOMATICALLY ASSIGN DIFFERENT time card numbers to ALL employee master files for the <u>current</u> pay period</p> <p>- OR -</p> <p>AUTOMATICALLY ASSIGN SAME time card numbers to ALL employee master files for the <u>current</u> pay period</p> <p>- AND / OR -</p> <p>NEXT PAY PERIOD: AUTOMATICALLY ASSIGN DIFFERENT time card numbers to ALL employee master files for the <u>next</u> pay period</p> <p>- OR -</p> <p>AUTOMATICALLY ASSIGN SAME time card numbers to ALL employee master files for the <u>next</u> pay period</p>	<p>83 E 88 E</p> <p>82 E 88 E</p> <p>83 E 99 E</p> <p>82 E 99 E</p>	<p>U 15</p> <p>U 15</p> <p>U 16</p> <p>U 15</p>
6	PRINT LIST of assigned time card numbers on report card	85 E	U 17
7	<p>For ALL employees: CURRENT PAY PERIOD: PRINT employee name on <u>ONE</u> side of the time card</p> <p>- OR -</p> <p>PRINT employee name on <u>BOTH</u> sides of the time card</p> <p>- AND / OR -</p> <p>NEXT PAY PERIOD: PRINT employee name on <u>ONE</u> side of the time card</p> <p>- OR -</p> <p>PRINT employee name on <u>BOTH</u> sides of the time card</p>	<p>80 E 1 E</p> <p>80 E 2 E</p> <p>81 E 1 E</p> <p>81 E 2 E</p>	<p>U 18</p> <p>U18-U19</p> <p>U 19</p> <p>U 20</p>

USER GUIDE

* USER SETUP PROCEDURES FOR EMPLOYEE MASTER FILE USING NEW CARD NUMBER

EMPLOYEE MASTER FILE USING NEW CARD NUMBER ASSIGNMENT METHOD PAY PERIOD ROUTINE			
STEP	WHAT TO DO	USER ACCESS CODE	PAGE
8	Place ALL employee time cards in the time card racks and you're ready to begin.	-----	-----

* These steps are only required if you are adding NEW information for the pay period.

*** OVERVIEW - INSTRUCTIONS FOR EMPLOYEE USE**

- 1) Remove time card from rack.
- 2) Insert time card in the card pocket located at the top of the clock.
- 3) The clock will automatically transport the card inside so the card sensor can read the time card number to process and print the punch.
- 4) When processing and printing is complete, the card will automatically be ejected.
- 5) Remove the time card from the clock and return to the rack.

USER GUIDE

* DEPARTMENT NUMBER FILE MAINTENANCE

The following User Access Codes will allow you to add up to fifty department numbers (per clock), print a list, delete individual department numbers and delete all department numbers.

- 7 2 E** = ADD Department Numbers
- Turn key to "FUNCTION" mode
 - Press '7 2 E'
- FOR EACH DEPARTMENT:
- Type in a valid six digit department number (000001 - 999999)
 - Press 'E'
- TO SORT NUMBERS AND SAVE TO MEMORY:
- Press 'I'
 - Turn key to "NORMAL" mode
-

- 7 3 E** = PRINT A LIST of Department Numbers
- Turn key to "FUNCTION" mode
 - Press '7 3 E'
 - Insert a report card. Remove when finished printing.
 - Turn key to "NORMAL" mode
-

- 7 1 E 7 7 E** = DELETE INDIVIDUAL Department Numbers
- Turn key to "FUNCTION" mode
 - Press '7 1 E 7 7 E'
- FOR EACH DEPARTMENT:
- Type in an existing department number
 - Press 'E'
- TO DELETE, RESORT, AND SAVE:
- Press 'I'
 - Turn key to "NORMAL" mode

*** DEPARTMENT NUMBER FILE MAINTENANCE**

7	0	E	7	7	E
---	---	---	---	---	---

= DELETE ALL Department Numbers

- Turn key to "FUNCTION" mode
- Press '7 0 E 7 7 E'
- The clock will delete the department file AND scroll through all employee file numbers (000-249) changing their department numbers to 000000.
- Turn key to "NORMAL" mode

USER GUIDE

* EMPLOYEE MASTER FILE MAINTENANCE

The following User Access Codes will allow you to add up to 250 employees (per time clock), print lists for all departments or specific departments with or without pay rates, delete individual employee master files and delete all employee master files.

6 1 E

= ADD Employee Master Files

- Turn key to "FUNCTION" mode
- Press '6 1 E'

FOR EACH EMPLOYEE MASTER FILE THERE ARE 5 STEPS:

Step 1 = File Number

- Type in a valid file number (000 - 249)
- Press '#' to advance to step 2

Step 2 = Employee ID#

- Type in up to a 10 digit ID# (0000000000 - 9999999999)
- Press '#' to advance to step 3

Step 3 = Employee Name

- Type in employee name by entering in the ASCII code equivalent for each letter. (refer to appendix).
- Press '#' to advance to step 4

Step 4 = Department Number

- Type in a valid existing department number
- Press '#' to advance to step 5

Step 5 = Pay Rate

- Type in employee's pay rate
- Press 'E'

- Insert a report card to print and verify information OR press 'E' to save.

- Enter next employee or turn key back to 'NORMAL' mode when finished.

6 2 E

PRINT A LIST of Employee Master Files (ALL DEPARTMENTS)

- Turn key to "FUNCTION" mode
- Press '6 2 E'

- Insert a report card. Remove when finished printing.

- Turn key to "NORMAL" mode

* EMPLOYEE MASTER FILE MAINTENANCE

- 6 3 E** = PRINT A LIST of Employee Master Files
(SPECIFIC DEPARTMENTS)
- Turn key to "FUNCTION" mode
 - Press '6 3 E'
 - Type in a valid existing department number
 - Press 'E'
 - Insert a report card. Remove when finished printing.
 - Turn key to "NORMAL" mode

- 6 4 E X X X X E** = PRINT A LIST WITH PAY RATES of Employee
Master Files (ALL DEPARTMENTS)
- Turn key to "FUNCTION" mode
 - Press '6 4 E'
 - Type in the valid password number and press 'E'
 - Insert a report card. Remove when finished printing.
 - Turn key to "NORMAL" mode

- 6 5 E X X X X E** = PRINT A LIST WITH PAY RATES of Employee
Master Files (SPECIFIC DEPARTMENTS)
- Turn key to "FUNCTION" mode
 - Press '6 5 E'
 - Type in the valid password number and press 'E'
 - Type in a valid existing department number
 - Press 'E'
 - Insert a report card. Remove when finished printing.
 - Turn key to "NORMAL" mode

USER GUIDE

* EMPLOYEE MASTER FILE MAINTENANCE

6 0 E 7 7 E = DELETE INDIVIDUAL employee's accumulated hours AND time card number assignment for previous, current and next pay periods.

- Turn key to "FUNCTION" mode
- Press '6 0 E 7 7 E'
- Type the employee master file number you wish to delete.
- Press 'E' to accept entry
- Press 'I' to delete ONLY the accumulated hours AND time card number assignment for previous, current and next pay periods for the selected employee.
- Turn key to "NORMAL" mode

6 0 E 8 8 E = DELETE INDIVIDUAL employee's entire master file (includes file number, employee number, employee name, department number, pay rate, AND accumulated hours AND time card number assignment for previous, current and next pay periods.)

- Turn key to "FUNCTION" mode
- Press '6 0 E 8 8 E'
- Type the employee master file number you wish to delete.
- Press 'E' to accept entry
- Press 'I' to delete entire master file from memory for the selected employee.
- Turn key to "NORMAL" mode

3 0 E 7 7 E X X X X E = DELETE ALL employees' accumulated hours AND time card number assignment for previous, current and next pay periods.

- Turn key to "FUNCTION" mode
- Press '3 0 E 7 7 E'
- Type in the valid password number and press 'E'
- The clock will delete all employee master files
- When display screen goes blank, turn the key to "NORMAL" mode

3 0 E 8 8 E X X X X E = DELETE ALL employee's entire master files (includes file number, employee number, employee name, department number, pay rate, AND accumulated hours AND time card number assignment for previous, current and next pay periods.)

- Turn key to "FUNCTION" mode
- Press '3 0 E 8 8 E'
- Type in the valid password number and press 'E'
- The clock will delete all employee master files
- When display screen goes blank, turn the key to "NORMAL" mode

*** TIME CARD NUMBER ASSIGNMENT**

The following User Access Codes will allow you to automatically assign the same time card number or a different time card number for the current or next pay period, manually assign individual time cards for the current or next pay period and print a list of card numbers.

8 2 E 8 8 E X X X X E =

AUTOMATICALLY ASSIGN SAME CARD NUMBERS to all employee master files for the current pay period

- Turn key to "FUNCTION" mode
- Press '8 2 E 8 8 E'
- Type in the valid password number and press 'E'
- Wait approximately 4 seconds until display screen goes blank
- Turn key to "NORMAL" mode

8 2 E 9 9 E X X X X E =

AUTOMATICALLY ASSIGN SAME CARD NUMBERS to all employee master files for the next pay period

- Turn key to "FUNCTION" mode
- Press '8 2 E 9 9 E'
- Type in the valid password number and press 'E'
- Wait approximately 4 seconds until display screen goes blank
- Turn key to "NORMAL" mode

8 3 E 8 8 E X X X X E =

AUTOMATICALLY ASSIGN DIFFERENT CARD NUMBERS to all employee master files for the current pay period.

- Turn key to "FUNCTION" mode
- Press '8 3 E 8 8 E'
- Type in the valid password number and press 'E'
- Type in the starting time card number and press 'E'. The time card number and file numbers will be displayed as they are being assigned in sequential order.
- When display screen goes blank, turn key to "NORMAL" mode

USER GUIDE

* TIME CARD NUMBER ASSIGNMENT

=

AUTOMATICALLY ASSIGN DIFFERENT CARD NUMBERS to all employee master files for the next pay period.

- Turn key to "FUNCTION" mode
 - Press '8 3 E 9 9 E'
 - Type in the valid password number and press 'E'
 - Type in the starting time card number and press 'E'. The time card number and file numbers will be displayed as they are being assigned in sequential order.
 - Turn key to "NORMAL" mode
-

= ASSIGN SPECIFIC CARD NUMBER to an individual employee for the current pay period.

- Turn key to "FUNCTION" mode
 - Press '8 4 E 8 8 E'
 - Press 'F' and then type in the employee master file number (for the employee you wish to assign the time card number).
 - Press 'E'
 - Insert time card. (The clock will check the memory to see if that time card number is already being used). The time card number will then be saved in memory and the clock will automatically increment to the next file number.
 - Assign next time card number or turn key back to "NORMAL" mode when finished
-

= ASSIGN SPECIFIC CARD NUMBER to an individual employee for the next pay period.

- Turn key to "FUNCTION" mode
- Press '8 4 E 9 9 E'
- Press 'F' and then type in the employee master file number (for the employee you wish to assign the time card number).
- Press 'E'

*** TIME CARD NUMBER ASSIGNMENT**

- Insert time card. (The clock will check the memory to see if that time card number is already being used). The time card number will then be saved in memory and the clock will automatically increment to the next file number.
 - Assign next time card number or turn key back to "NORMAL" mode when finished
-

8	5	E
---	---	---

- = PRINT LIST of assigned time card numbers
- Turn key to "FUNCTION" mode
 - Press '8 5 E'
 - Insert a report card. Remove when finished printing.
 - Turn key to "NORMAL" mode

USER GUIDE

* TIME CARD NAME PRINTING

The following User Access Codes will allow you to print the employee name, pay ending date, ID#, department number, file number and time card number on one or both sides of the time card for the current or next pay period.

8 0 E 1 E

= NAME PRINTING for the current pay period on ONE SIDE of the time card.

- Turn key to "FUNCTION" mode
- Press '8 0 E 1 E'
- Press 'F' and then type in the employee master file number (for the employee you wish to assign the time card number).
- Press 'E'
- The employee master file number will appear in the right hand corner of the display screen and the time card number will appear in the upper left hand corner. Verify that the ACTUAL time card number is the same as the time card number displayed.
- Insert the time card UPSIDE DOWN ON SIDE 1 (When finished printing the card will automatically be ejected.) Remove card.
- The display will automatically advance to the next available file number and card number.
- Insert the next card for the next employee and continue until all name printing is complete.
- When finished name printing for all employees, turn key to "NORMAL" mode.

8 0 E 2 E

= NAME PRINTING for the current pay period on BOTH SIDES of the time card.

- Turn key to "FUNCTION" mode
- Press '8 0 E 2 E'
- Press 'F' and then type in the employee master file number (for the employee you wish to assign the time card number).
- Press 'E'
- The employee master file number will appear in the right hand corner of the display screen and the time card number will appear in the upper left hand corner. Verify that the ACTUAL time card number is the same as the time card number displayed.

* TIME CARD NAME PRINTING

- Insert the time card UPSIDE DOWN ON SIDE 1
(When finished printing the card will automatically be ejected.) Remove card.
- Reinsert the time card UPSIDE DOWN ON SIDE 2
(When finished printing the card will automatically be ejected.) Remove card.
- The display will automatically advance to the next available file number and card number.
- Insert the next card for the next employee and continue until all name printing is complete.
- When finished name printing for all employees, turn key to "NORMAL" mode.

8 1 E 1 E

- = NAME PRINTING for the next pay period on ONE SIDE of the time card.
- Turn key to "FUNCTION" mode
- Press '8 1 E 1 E'
- Press 'F' and then type in the employee master file number (for the employee you wish to assign the time card number).
- Press 'E'
- The employee master file number will appear in the right hand corner of the display screen and the time card number will appear in the upper left hand corner. Verify that the ACTUAL time card number is the same as the time card number displayed.
- Insert the time card UPSIDE DOWN ON SIDE 1
(When finished printing the card will automatically be ejected.) Remove card.
- The display will automatically advance to the next available file number and card number.
- Insert the next card for the next employee and continue until all name printing is complete.
- When finished name printing for all employees, turn key to "NORMAL" mode.

USER GUIDE

* TIME CARD NAME PRINTING

8 1 E 2 E

= NAME PRINTING for the next pay period on BOTH SIDES of the time card.

- Turn key to "FUNCTION" mode
- Press '8 1 E 2 E'
- Press 'F' and then type in the employee master file number (for the employee you wish to assign the time card number).
- Press 'E'
- The employee master file number will appear in the right hand corner of the display screen and the time card number will appear in the upper left hand corner. Verify that the ACTUAL time card number is the same as the time card number displayed.
- Insert the time card UPSIDE DOWN ON SIDE 1 (When finished printing the card will automatically be ejected.) Remove card.
- Reinsert the time card UPSIDE DOWN ON SIDE 2 (When finished printing the card will automatically be ejected.) Remove card.
- The display will automatically advance to the next available file number and card number.
- Insert the next card for the next employee and continue until all name printing is complete.
- When finished name printing for all employees, turn key to "NORMAL" mode.

* DATA CORRECTION

The following User Access Codes will allow you to correct accumulated hours on an employee's time card for the current or previous pay periods. All corrections will be printed in red. If the clock is set up to calculate in regular minutes then the correction data should be entered in regular minutes (:00-:59). If the clock is set up to calculate in hundredths then the correction data should be entered in hundredths of an hour (.00-.98).

1 E

- = INDIVIDUAL DATA CORRECTION for current pay period
- Turn key to "FUNCTION" mode
- Press '1 E'
- Type the employee master file number for the employee you wish to correct.
(refer to the employee list for the employee master file number)
- Press 'E'

THERE ARE 5 PAY CATEGORIES FOR CORRECTION:

(The category number will appear in the upper left hand corner on the display and the amount of hours in that category will also be displayed.)

1 = DAILY NET HOURS - to adjust hours for the current day.

** Hours entered here will automatically be sorted into regular and overtime pay categories (based on the programmed amount of daily hours in address 101) and added to the weekly net hours category.

2 = WEEKLY NET HOURS - to adjust hours for the current week.

** Hours entered here will automatically be sorted into regular and overtime pay categories (based on the programmed amount of weekly hours in address 102).

For bi-weekly 8/40, semi-monthly and monthly pay periods, sorting of the corrected hours will be based on the hours calculated during the last week of the pay period.

USER GUIDE

* DATA CORRECTION

3 = REGULAR HOURS - to adjust hours in the accumulated regular hours pay category ONLY, for the current week.

** Hours entered here will be added directly to the REGULAR hours pay category. No other pay categories will be affected.

4 = OVERTIME A HOURS - to adjust hours in the accumulated overtime A hours pay category ONLY, for the current week.

** Hours entered here will be added directly to the OVERTIME A hours pay category. No other pay categories will be affected.

5 = OVERTIME B HOURS - to adjust hours in the accumulated overtime B hours pay category ONLY, for the current week.

** Hours entered here will be added directly to the OVERTIME B hours pay category. No other pay categories will be affected.

- Type in the amount of hours for the correction
 - Press '+' to add or '-' to subtract
 - Press 'E' to store and advance to next category

 - When finished making corrections for this employee insert their time card (for the current pay period and the corrections will print in red.

 - Enter next employee master file number or turn key back to 'NORMAL' mode when finished.
-

2 E

= INDIVIDUAL DATA CORRECTION for previous pay period

- Turn key to "FUNCTION" mode
 - Press '2 E'

 - Type the employee file number for the employee you wish to make the correction to. (refer to the employee list for the employee master file number)
 - Press 'E'
-

*** DATA CORRECTION**

THERE ARE 4 PAY CATEGORIES FOR CORRECTIONS:

(The category number will appear in the upper left hand corner on the display and the amount of hours in that category will also be displayed.)

1 = WEEKLY NET HOURS - to adjust hours for the previous week.

** Hours entered here will automatically be sorted into regular and overtime pay categories (based on the programmed amount of weekly hours in address 102).

This category will only be available for weekly and bi-weekly 8/80 pay periods.

2 = REGULAR HOURS - to adjust hours in the accumulated regular hours pay category ONLY, for the previous week.

** Hours entered here will be added directly to the REGULAR hours pay category. No other pay categories will be affected.

3 = OVERTIME A HOURS - to adjust hours in the accumulated overtime A hours pay category ONLY, for the previous week.

** Hours entered here will be added directly to the OVERTIME A hours pay category. No other pay categories will be affected.

4 = OVERTIME B HOURS - to adjust hours in the accumulated overtime B hours pay category ONLY, for the previous week.

** Hours entered here will be added directly to the OVERTIME B hours pay category. No other pay categories will be affected.

-
- Type in the amount of hours for the correction
 - Press '+' to add or '-' to subtract
 - Press 'E' to store and advance to next category
 - When finished making corrections for this employee insert their time card (from the previous pay
 - Enter next employee master file number or turn key back to 'NORMAL' mode when finished.

USER GUIDE

* INDIVIDUAL TIME CARD SUMMARY

The following User Access Codes will allow you to print a summary of total, regular and overtime hours worked on the employee's time card for the current or previous pay periods. The same summary can also be printed in dollars. (Hours worked x employee's pay rate.)

3 E = INDIVIDUAL TIME CARD SUMMARY for current pay period.

- Turn key to "FUNCTION" mode
- Press '3 E'
- Insert employee's time card. Remove when finished printing.
- Turn key to "NORMAL" mode

4 E = INDIVIDUAL TIME CARD SUMMARY for previous pay period.

- Turn key to "FUNCTION" mode
- Press '4 E'
- Insert employee's time card. Remove when finished printing.
- Turn key to "NORMAL" mode

5 E X X X X E = INDIVIDUAL TIME CARD SUMMARY WITH DOLLARS for the current pay period.

- Turn key to "FUNCTION" mode
- Press '5 E'
- Type in the valid password number and press 'E'
- Insert employee's time card. Remove when finished printing.
- Turn key to "NORMAL" mode

6 E X X X X E = INDIVIDUAL TIME CARD SUMMARY WITH DOLLARS for the previous pay period.

- Turn key to "FUNCTION" mode
- Press '6 E'
- Type in the valid password number and press 'E'
- Insert employee's time card. Remove when finished printing.
- Turn key to "NORMAL" mode

* REPORTS - ACCUMULATED PERIOD HOURS

The following User Access Codes will allow you to print detail reports that include each employee's accumulated total, regular and overtime hours within a department along with department subtotals and a grand total. Reports can be selected by ALL departments or by specific departments for the current or previous pay periods.

4 0 E = PRINT ACCUMULATED PERIOD HOURS DETAIL REPORT for the current pay period. (ALL DEPARTMENTS)

- Turn key to "FUNCTION" mode
- Press '4 0 E'
- Insert a report card. Remove when finished printing.
- Turn key to "NORMAL" mode

4 1 E = PRINT ACCUMULATED PERIOD HOURS DETAIL REPORT for the previous pay period. (ALL DEPARTMENTS)

- Turn key to "FUNCTION" mode
- Press '4 1 E'
- Insert a report card. Remove when finished printing.
- Turn key to "NORMAL" mode

4 2 E = PRINT ACCUMULATED PERIOD HOURS DETAIL REPORT for the current pay period. (SPECIFIC DEPARTMENTS)

- Turn key to "FUNCTION" mode
- Press '4 2 E'
- Type in a valid existing department number
- Press 'E'
- Insert a report card. Remove when finished printing.
- Turn key to "NORMAL" mode

4 3 E = PRINT ACCUMULATED PERIOD HOURS DETAIL REPORT for the previous pay period. (SPECIFIC DEPARTMENTS)

- Turn key to "FUNCTION" mode
- Press '4 3 E'
- Type in a valid existing department number
- Press 'E'
- Insert a report card. Remove when finished printing.
- Turn key to "NORMAL" mode

USER GUIDE

* REPORTS - ACCUMULATED PERIOD DOLLARS

The following User Access Codes will allow you to print detail reports that include each employee's accumulated total, regular and overtime dollars within a department along with department subtotals and a grand total. Reports can be selected by ALL departments or by specific departments for the current or previous pay periods.

- 4 4 E X X X X E** = PRINT ACCUMULATED PERIOD DOLLARS DETAIL REPORT for the current pay period. (ALL DEPARTMENTS)
- Turn key to "FUNCTION" mode
 - Press '4 4 E'
 - Type in the valid password number and press 'E'
 - Insert a report card. Remove when finished printing.
 - Turn key to "NORMAL" mode

- 4 5 E X X X X E** = PRINT ACCUMULATED PERIOD DOLLARS DETAIL REPORT for the previous pay period. (ALL DEPARTMENTS)
- Turn key to "FUNCTION" mode
 - Press '4 5 E'
 - Type in the valid password number and press 'E'
 - Insert a report card. Remove when finished printing.
 - Turn key to "NORMAL" mode

- 4 6 E X X X X E** = PRINT ACCUMULATED PERIOD DOLLARS DETAIL REPORT for the current pay period. (SPECIFIC DEPARTMENTS)
- Turn key to "FUNCTION" mode
 - Press '4 6 E'
 - Type in the valid password number and press 'E'
 - Type in a valid existing department number
 - Press 'E'
 - Insert a report card. Remove when finished printing.
 - Turn key to "NORMAL" mode

* REPORTS - ACCUMULATED PERIOD DOLLARS

- 4
7
E
X
X
X
X
E = PRIM ACCUMULATED PERIOD DOLLARS DETAIL
 REPCT for the previous pay period.
 (SPECIFIC DEPARTMENTS)
- Turn key to "FUNCTION" mode
 - Prss '4 7 E'
 - Tye in the valid password number and prss 'E'
 - Tye in a valid existing department number
 - Prss 'E'
 - Inert a report card. Remove when fiished printing.
 - Turn key to "NORMAL" mode

USER GUIDE

* REPORTS - YESTERDAY'S HOURS / DOLLARS

The following User Access Codes will allow you to print reports that include yesterday's total, regular and overtime hours worked or dollars sorted by department number.

4 8 E = PRINT YESTERDAY'S HOURS REPORT

- Turn key to "FUNCTION" mode
- Press '4 8 E'
- Insert a report card. Remove when finished printing.
- Turn key to "NORMAL" mode

4 9 E X X X X E = PRINT YESTERDAY'S DOLLARS REPORT

- Turn key to "FUNCTION" mode
- Press '4 9 E'
- Type in the valid password number and press 'E'
- Insert a report card. Remove when finished printing.
- Turn key to "NORMAL" mode

* REPORTS - TODAY'S HOURS / DOLLARS

The following User Access Codes will allow you to print reports that include today's total, regular and overtime hours worked or dollars sorted by department number.

- 5 0 E** = PRINT TODAY'S HOURS REPORT
- Turn key to "FUNCTION" mode
 - Press '5 0 E'
 - Insert a report card. Remove when finished printing.
 - Turn key to "NORMAL" mode

- 5 1 E X X X X E** = PRINT TODAY'S DOLLARS REPORT
- Turn key to "FUNCTION" mode
 - Press '5 1 E'
 - Type in the valid password number and press 'E'
 - Insert a report card. Remove when finished printing.
 - Turn key to "NORMAL" mode

USER GUIDE

* REPORTS - APPROACHING OVERTIME

The following User Access Codes will allow you to print an approaching overtime report by specifying a minimum amount of hours employees have worked before appearing on the report.

5 **2** **E** = PRINT APPROACHING OVERTIME REPORT

- Turn key to "FUNCTION" mode
- Press '5 2 E'
- Type in the amount of weekly worked hours limit for the pay period. (All employees that have worked greater than that amount will print out on report.)
- Press 'E'
- Insert a report card. Remove when finished printing.
- Turn key to "NORMAL" mode

*** REPORTS - PUNCHED IN**

The following User Access Codes will allow you to print a punched in report that will include all employee's currently punched in on the clock and the time that they punched in.

5 3 E = PRINT PUNCHED IN REPORT (ALL DEPARTMENTS)

- Turn key to "FUNCTION" mode
- Press '5 3 E'
- Insert a report card. Remove when finished printing.
- Turn key to "NORMAL" mode

5 4 E = PRINT PUNCHED IN REPORT (SPECIFIC DEPARTMENTS)

- Turn key to "FUNCTION" mode
- Press '5 4 E'
- Type in a valid existing department number
- Press 'E'
- Insert a report card. Remove when finished printing.
- Turn key to "NORMAL" mode

USER GUIDE

* REPORTS - PUNCHED OUT

The following User Access Codes will allow you to print a punched out report that will include all employee's currently punched out on the clock and the time that they punched out.

- 5 5 E** = PRINT PUNCHED OUT REPORT (ALL DEPARTMENTS)
- Turn key to "FUNCTION" mode
 - Press '5 5 E'
 - Insert a report card. Remove when finished printing.
 - Turn key to "NORMAL" mode
-

- 5 6 E** = PRINT PUNCHED OUT REPORT (SPECIFIC DEPARTMENTS)
- Turn key to "FUNCTION" mode
 - Press '5 6 E'
 - Type in a valid existing department number
 - Press 'E'
 - Insert a report card. Remove when finished printing.
 - Turn key to "NORMAL" mode

*** PASSWORD MAINTENANCE**

The following User Access Code will allow you to change your existing password.

1 1 E = Password Maintenance

- Turn key to "FUNCTION" Mode
- Press '1 1 E'
- Type in the valid existing password number
- Press 'E'
- Type in the new password number (up to 4 digits)
- Press '#'
- Retype in the new password number to confirm
- Press 'E'
- Turn key to "NORMAL" mode

MAINTENANCE

* DIAGNOSTICS - MEMORY TEST

9 0 E = MEMORY TEST for ALL areas of memory on the main printed circuit board, keypad and display screen.

- Turn the key to "FUNCTION" mode
- Press '9 0 E'

* The clock will begin checking area 0:

This is a RAM work area where all calculations take place.

The display screen will start scrolling backwards from 100 down to 0 on the left while displaying 0 on the right.

* The clock will then begin checking area 1:

This is the RAM BANK0 where all of the programming data, department numbers, and part of the employee master files and accumulated hours are stored.

The display screen will start scrolling backwards from 100 down to 0 on the left while displaying 1 on the right.

* The clock will then begin checking area 2:

This is the RAM BANK1 where part of the employee master files and accumulated hours are stored.

The display screen will start scrolling backwards from 100 down to 0 on the left while displaying 2 on the right.

* The clock will then begin checking area 3:

This is the RAM BANK2 where part of the employee master files and accumulated hours are stored.

The display screen will start scrolling backwards from 100 down to 0 on the left while displaying 3 on the right.

** IF ANY PROBLEMS ARE DETECTED THE DISPLAY WILL STOP ON THE NUMBER WHERE THE PROBLEM LIES. CALL YOUR AMANO REPRESENTATIVE IMMEDIATELY FOR PROPER SERVICE.

* DIAGNOSTICS - MEMORY TEST

- * When the memory test is completed, the clock will test the employee master file numbers:

The display screen will start scrolling backwards from 249 down to 000 on the upper left hand corner.

When finished scrolling every available item on the display screen will be turned on for approximately 4 seconds.

- When the display goes blank, test the keypad by pressing each key in the order presented:

'F' key displays ' F '
 'E' key displays ' E '
 '#' key displays ' d '
 'CL' key displays ' C '

'9' key displays ' 9 '
 '6' key displays ' 6 '
 '3' key displays ' 3 '
 '-' key displays ' b '
 '8' key displays ' 8 '
 '5' key displays ' 5 '
 '2' key displays ' 2 '
 '+' key displays ' A '

'7' key displays ' 7 '
 '4' key displays ' 4 '
 '1' key displays ' 1 '
 '0' key displays ' 0 '

'I' key displays ' L '
 'II' key displays two half sized lines.
 'III' key displays the bottom half of a zero.
 'IV' key displays ' P '

- After the 'IV' key is pressed the display will go blank and then the card symbol will appear on the bottom.
- Insert a report card to print the sensor test. (Refer to page U 37 to compare results)
- Turn the key back to "NORMAL" mode

MAINTENANCE

* DIAGNOSTICS - PRINTER TEST

9 1 E = PRINTER TEST for dot matrix printer and ribbon cartridge.

- Turn the key to "FUNCTION" mode
- Press '9 1 E'

- Insert report card. The clock will print in black on one line and then in red on the line beneath it making sure that all available characters print on every print position on the card. The card will automatically continue to eject and be pulled back into card transport until the entire card is full. You may remove the card at anytime.

- Turn the key back to "NORMAL" mode

* **DIAGNOSTICS SENSOR TEST**

9 2 E = SENSOR TEST for home sensor, timing sensor, and card sensor and card reader.

-Turn the key to "FUNCTION" mode
 -Press '9 2 E'

-Insert a report card. The sensor levels will be printed and the card will automatically eject.

Remove the card and compare to the normal sensor levels:

H T C	Y X 0 1 2 3 4 5 6 7 8 9
7 7 5	4 4 4 4 4 4 4 4 4 4 4 4

H = Home Sensor: assures that the print head starts at the left most position.

T = Timing Sensor: assures that the punch is printed in the proper position on the time card.

C = Card Sensor: senses when a card is inserted into the clock.

Y-9 = Card Reader: Reads the holes on the bottom of the time card to identify employee punching in or out.

If your printout looks different, you should call your Amano Representative to clean or replace the sensor(s).

- Turn the key back to "NORMAL" mode

MAINTENANCE

* REPLACING RIBBON CARTRIDGE

When the printing on the time card becomes too light replace the ribbon cartridge:

1. Insert the key into the keyhole on the front of the cover case and turn to the right to unlock. Remove the cover case.
2. Remove the white thumb screw (1) located below the keypad panel.
3. Lift up the keypad panel (2). Rotate the black gear (3) located on the right hand side of the frame, until the ribbon cartridge moves to the right side slightly.
4. To remove the ribbon cartridge, raise the end up and lift it out.
5. Place the new cartridge in the cartridge casing in a slanted position and make sure the protrusions on both ends snap into position.
6. Slowly lower the front portion of the cartridge while turning the knob on the cartridge. Ensure that the ribbon is in the ribbon guide.
7. To check for proper printing, run a printer test by placing the key in the keyhole next to the card pocket. Turn the key to the right into "FUNCTION" mode. Press '9 1 E' and insert a report card.
8. Once printing has been verified, turn the key back to "NORMAL" mode and remove from the keyhole.
9. Replace cover case and lock.

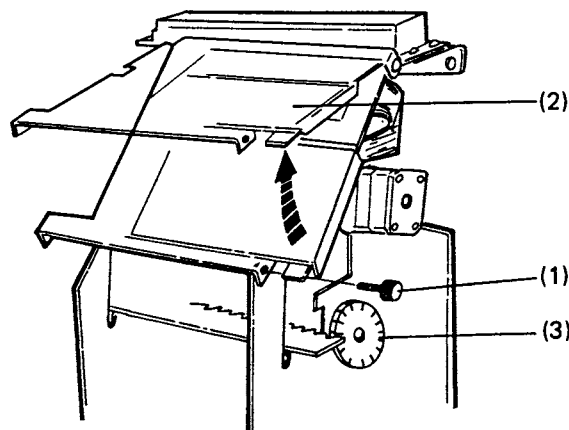

**** This page intentionally left blank ****

*** MJR-8000 ERROR CODE LIST / SOLUTION**

ERROR CODE	REASON	SOLUTION
0 - 01	Inserted time card facing the wrong side.	Reinsert time card facing the correct side.
0 - 08	<ol style="list-style-type: none"> 1) Time card number has already been assigned. 2) Inserted wrong time card for printing of correction hours. 	<ol style="list-style-type: none"> 1) Insert an unassigned time card. 2) Insert correct time card.
0 - 12	Inserted time card during lock out period.	Override lock out by using lock out release card, if authorized.
1 - 20	<ol style="list-style-type: none"> 1) Employee master file number does not exist. 2) Invalid user access code 3) Approaching overtime limit for report is out of range. 	<ol style="list-style-type: none"> 1) Enter correct employee master file number. 2) Enter correct user access code. 3) Enter a valid limit 00:00 - 60:00.
1 - 22	Incorrect card inserted during card assignment, name printing or card assignment.	Insert correct time card.
1 - 30	Improper time card. (Too Short)	Reissue proper size, properly coded, time card.

ERROR CODES

* MJR-8000 ERROR CODE LIST / SOLUTION

ERROR CODE	REASON	SOLUTION
1 - 31	Improper time card. (Too Long)	Reissue proper size, properly coded, time card.
2 - 01	Incorrect password.	Enter correct password.
2 - 10	Department buffer full.	Cannot enter any more department numbers. A maximum of 50 departments can be stored in memory.
2 - 11	Department number already exists.	Enter a different department number.
2 - 12	Department number doesn't exist.	Enter an existing department number.
2 - 13	Department and/or file number is out of valid range.	Enter a valid dept. number (000001-999999) or enter a valid employee file number (000-249).

* MJR-8000 ERROR CODE LIST / SOLUTION

ERROR CODE	REASON	SOLUTION
<div style="border: 1px solid black; padding: 5px; width: fit-content; margin: auto;"> 2 - 14 </div>	Access Code entered is not available for the traditional time card number assignment method.	Input an available Access Code. Refer to pages P8 and P9.
<div style="border: 1px solid black; padding: 5px; width: fit-content; margin: auto;"> 8 - 80 x </div>	Incorrect data programmed.	Clear program memory of applicable area and reprogram.
<div style="border: 1px solid black; padding: 5px; width: fit-content; margin: auto;"> 8 - 85 x </div>	Individual data file reading error.	Turn key switch to "FUNCTION" mode. Press CL key to clear. Re-enter data as needed
<div style="border: 1px solid black; padding: 5px; width: fit-content; margin: auto;"> 8 - 88 x </div>	CPU (memory) defect.	Turn key switch to "FUNCTION" mode. Press CL key to clear.
<div style="border: 1px solid black; padding: 5px; width: fit-content; margin: auto;"> 9 - 50 x </div>	Inserted time card for printing earlier than previously printed time.	Press CL key. Make sure the clock is set to the current date and time.
<div style="border: 1px solid black; padding: 5px; width: fit-content; margin: auto;"> 9 - 60 x </div>	Temporary defect of software caused by noise or surge from outside power source.	Resets automatically in 3 seconds after error display.

ERROR CODES

* MJR-8000 ERROR CODE LIST / SOLUTION

ERROR CODE	REASON	SOLUTION
9 - 61 x	Temporary defect of CPU caused by noise or surge from outside power source.	Resets automatically in 3 seconds after error display.
9 - 70 x	Hardware problem. (printer timing impulse, sensor, motor, etc.)	Clear entry by CL key and clean sensors.
9 - 90 x	Card reading failure.	Press CL key and call service.
9 - 91 x	Card sensor level defect.	Press CL key and call service.

*** ASCII TABLE CHARACTER TRANSLATION**UPPER CASE LETTERS

<u>CHARACTER</u>	<u>CODE</u>
A	65
B	66
C	67
D	68
E	69
F	70
G	71
H	72
I	73
J	74
K	75
L	76
M	77
N	78
O	79
P	80
Q	81
R	82
S	83
T	84
U	85
V	86
W	87
X	88
Y	89
Z	90

OTHER CHARACTERS:

<u>CHARACTER</u>	<u>CODE</u>
Comma (,)	44
Space	32
Period (.)	46
Apostrophe (')	39

NOTES

NOTES

AMANO®

*Corporate Headquarters
140 Harrison Avenue, Roseland, NJ 07068-1239
(800) 526-2559*

www.amano.com