

# AMANO®

## PIX-55

Atomic Time Clock

Operation Manual



## Proprietary Notice

This document contains proprietary information and such information may not be reproduced in whole or part without the written permission from Amano Cincinnati, Inc. 140 Harrison Ave., Roseland, New Jersey 07068.

Amano Cincinnati, Inc. reserves the right to make equipment changes and improvements, which may not be reflected in this document. Portions of this document may have been updated to include the latest hardware or firmware version, if applicable. We recommend that this document be read in its entirety before any attempt is made to operate the equipment.

### *Thank You....*

For purchasing another fine product from  
Amano Cincinnati, Inc.



**Important!** Do not return this clock to the retailer. If you have any questions or need assistance, please call us toll free at 1-800-253-9836

Need Ribbons, Keys and Accessories?  
Visit  
[www.amano.com/time](http://www.amano.com/time)  
Or call 1-800-253-9836

## Warranty Notice

Any claim for warranty, express or implied, due to the clock's failure to properly receive the radio signal because of interference, whatever the source of this interference may be, are hereby expressly excluded.

For more information about the WWVB radio signal, actual signal coverage in North America visit NIST's website at: <http://tf.nist.gov/stations/radioclocks.htm>

For actual signal coverage in North America visit:  
[www.boulder.nist.gov/timefreq/stations/wwvbcovrage.htm](http://www.boulder.nist.gov/timefreq/stations/wwvbcovrage.htm)

## Specifications

### Power Requirements

**For Clock Input:** 16.5 VDC, 60Hz, 0.6A (Max.)

**For AC Adapter:** 100 VAC  $\pm$  10%, 50/60Hz

120 VAC  $\pm$  10%, 60Hz

230 VAC  $\pm$  10%, 50/60Hz

**Battery:** Lithium Battery for Memory Backup in case of power failure (factory installed).

**Ambient Temperature:** -10°C to 45°C (14°F to 113°F)

**Ambient Humidity:** 10% to 90% (non-condensing)

**Dimensions:** 6-11/16"(170 mm) Wide X 6- 7/16"(163 mm) High X 6-5/8"(168 mm) Deep.

**Weight:** Approximately 3.6 lbs. (1.63 kg)

**Environment:** Indoor use only; dust-free environment. Keep out of direct sunlight.

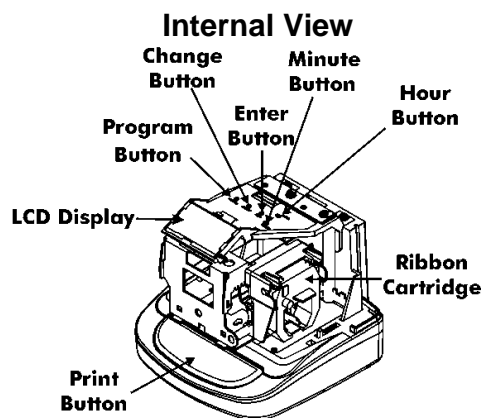
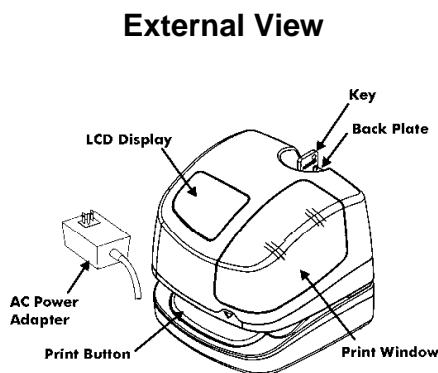

- The **PROGRAM** button is used to enter and exit the Program Mode.
- The **CHANGE** button is used to change the information on the display.
- The **ENTER** button is used to accept the information shown on the display and save it in memory.
- The **HOUR** button advances the hour in the display by increments of 1.
- The **MINUTE** button advances the minutes in the display by increments of 1.

## Display View

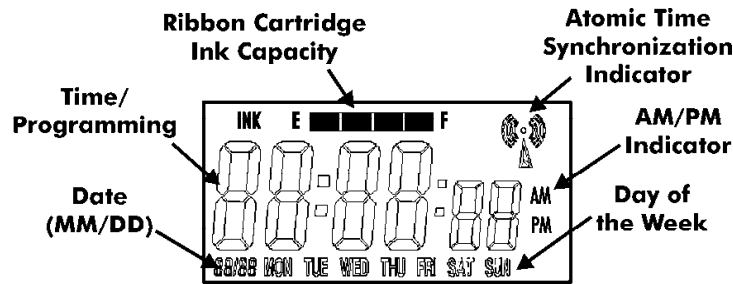

The LCD Display contains an Ink Capacity gauge. This gauge indicates the amount of ink remaining in the ribbon cartridge using four bar segments, from E (Empty) to F (Full).

The PIX-55 calculates the ink capacity of the ribbon cartridge from the number of imprints made. As the ink capacity decreases, the bars in the gauge will disappear. When the ribbon capacity drops below 25%, the “E”, “F” and “INK” characters will blink until the ribbon is replaced and the ink counter is reset.

## Removing the Cover and Packing Material

1. Insert the key provided and turn clockwise to unlock the cover.
2. Lift the cover to remove.
3. Remove the spacer between the Ribbon Cartridge and the Printer Carriage.

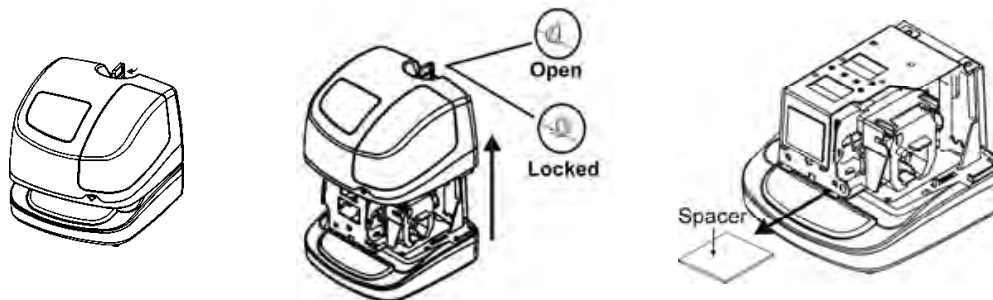

## Making a Test Print

1. Make sure the PIX-55 is plugged in.
2. Insert a piece of paper or time card into the PIX-55. The clock will automatically print YEAR, MONTH, DATE and TIME with AM or PM.

'09MAR 23 4:47PM

3. If the imprint is satisfactory, the PIX-55 is ready for use.

## Setting the Time (If Displayed Time is Incorrect or In Different Time Zone)

1. Unlock and remove the cover.
2. Press the **HOURL** advance button until the correct hour appears.
3. Press the **MINUTE** advance button until the correct minute appears.



**Note** – You must follow this procedure if you are installing the PIX-55 in a different Time Zone from where it is currently programmed.

## Setting the Month and Date

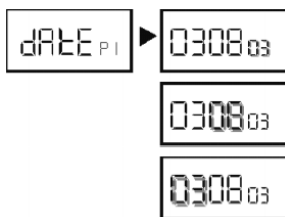

1. Press the **PROGRAM** button until **DATE P1** appears, then release. Next press the **ENTER** button.
2. Press the **CHANGE** button until the correct year appears, then press the **ENTER** button.
3. Press the **CHANGE** button until the correct date appears, then press the **ENTER** button.
4. Press the **CHANGE** button until the correct month appears, then press the **ENTER** button.
5. The display should now be flashing the correct month, date and year. Press the **ENTER** button to save.
6. Press the **PROGRAM** button to exit.

## Changing the Print Style

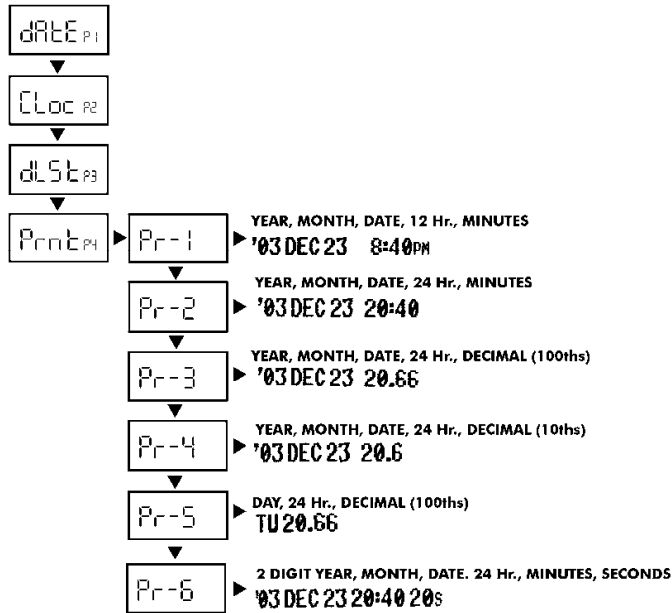

1. Press the **PROGRAM** button until **DATE P1** appears.
2. Press the **CHANGE** button until **Prnt P4** flashes in the display. Press the **ENTER** button.
3. The display will flash the current setting. Press the **CHANGE** button until the desired print style code appears (see diagram).
4. When the display flashes the correct setting, press the **ENTER** button and press the **PROGRAM** button to exit.

## Changing the Print Direction

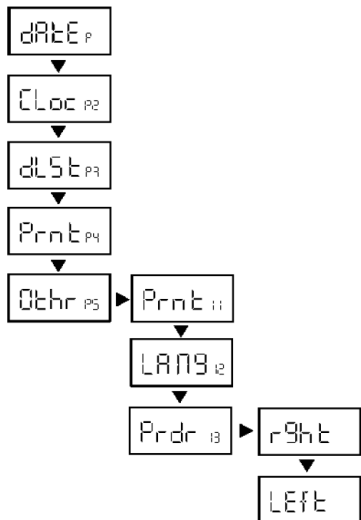

1. Press the **PROGRAM** button until **DATE P1** appears.
2. Press the **CHANGE** button until **Othr P5** flashes in the display. Press the **ENTER** button.
3. Press the **CHANGE** button until **Prdr I3** flashes in the display. Press the **ENTER** button.
4. Press the **CHANGE** button until the desired print direction **rght** (Right Side) or **LEft** (Left Side) flashes in the display, then press the **ENTER** button.
5. Press the **PROGRAM** button to exit.

## Enabling or Disabling Daylight Saving Time



**Note** – when this setting is set to **ON**, the clock's time will automatically change for DST. When this setting is set to **OFF**, the clock's time will not change for DST.

(To program the dates for the begin and end DST, refer to the Other Options Menu sections, below.)

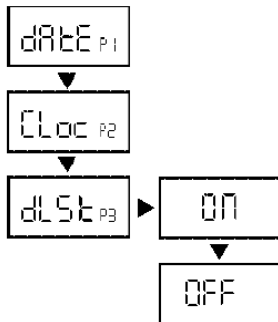

1. Press the **PROGRAM** button for two seconds, then press the **CHANGE** button until **dLSt P3** flashes in the display.
2. Press the **ENTER** button.
3. Press the **CHANGE** button to alternate between ON and OFF.
4. When the display flashes the correct setting, press the **ENTER** button.
5. When the display flashes **dLSt P3**, press the **PROGRAM** button to exit the Program Mode.

## Changing the Begin Date for DST: Other Options Menu



**Note** – the government standard for DST is subject to change. Your clock is factory set for correct DST based upon when it was manufactured, but any revision to DST begin or end dates may require updating the system-set DST calendar.

The steps below change the begin date for DST. Updating the begin date for DST needs to be done just one time, since the clock's rolling calendar function will auto-calculate the begin date for each year thereafter. To change the *end* date for DST, refer to the next section.



1. Press the **PROGRAM** button for two seconds, then the **CHANGE** button until **01 hr P5** flashes in the display.
2. Press the **ENTER** button.
3. Press the **CHANGE** button until **bdL 16** (begin Daylight Saving Time Date) flashes in the display.
4. Press the **ENTER** button.
5. The display shows the current month, date and year for the beginning of DST (year 2009 shown). The year flashes, indicating the year is the first part of the DST Begin Date that can be adjusted.
6. Press the **CHANGE** button until the year shows the correct year for the beginning year for the DST modification.
7. Press **ENTER**. The date flashes.

8. Press the **CHANGE** button until the date shows the correct date for the beginning date for the DST modification.
9. Press **ENTER**. The month flashes.
10. Press the **CHANGE** button until the month shows the correct month for the beginning month for the DST modification.
11. Press **ENTER**.
12. When the display flashes the correct selection, press the **ENTER** button, then the **PROGRAM** button, to save changes and exit the DST function.

## Changing the End Date for DST: Other Options Menu



**Note** – the government standard for DST is subject to change. Your clock is factory set for correct DST based upon when it was manufactured, but any revision to DST begin or end dates may require updating the system-set DST calendar.

The steps below change the end date for DST. Updating the end date for DST needs to be done just one time, since the clock's rolling calendar function will auto-calculate the end date for each year thereafter. To change the *begin* date for DST, refer to the previous section.



1. Press the **PROGRAM** button for two seconds, then the **CHANGE** button until **01 hr P5** flashes in the display.
2. Press the **ENTER** button.
3. Press the **CHANGE** button until **EdLt 11** (end Daylight Saving Time Date) flashes in the display.
4. Press the **ENTER** button.
5. The display shows the current month, date and year for the end of DST (year 2009 shown). The year flashes, indicating the year is the first part of the DST End Date that can be adjusted.
6. Press the **CHANGE** button until the year shows the correct year for the beginning year for the DST modification.
7. Press **ENTER**. The date flashes.
8. Press the **CHANGE** button until the date shows the correct date for the beginning date for the DST modification.
9. Press **ENTER**. The month flashes.
10. Press the **CHANGE** button until the month shows the correct month for the beginning month for the DST modification.
11. Press **ENTER**.
12. When the display flashes the correct selection, press the **ENTER** button, then the **PROGRAM** button, to save changes and exit the DST function.



## Enabling or Disabling Auto Print

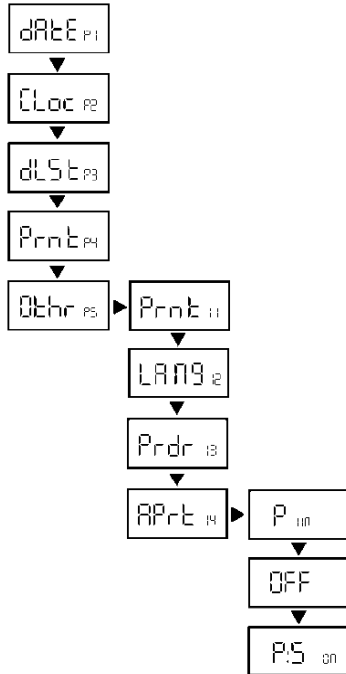

1. Press the **PROGRAM** button until dAtE P1 appears.
2. Press the **CHANGE** button until Othr P5 flashes in the display. Press the **ENTER** button.
3. Press the **CHANGE** button until APrt P4 flashes in the display. Press the **ENTER** button.
4. Press the **CHANGE** button until the desired code appears on the display, then press the Enter button. The Auto Print codes are as follows:

Code	Mode	Description
P on	Auto Print	Will automatically print a single print when media is inserted.
OFF	Manual Print	Requires you to use the <b>PRINT</b> button when printing.
P:5 on	DO NOT USE	

5. Press the **PROGRAM** button to exit.

## Wall Mounting

Placement considerations:

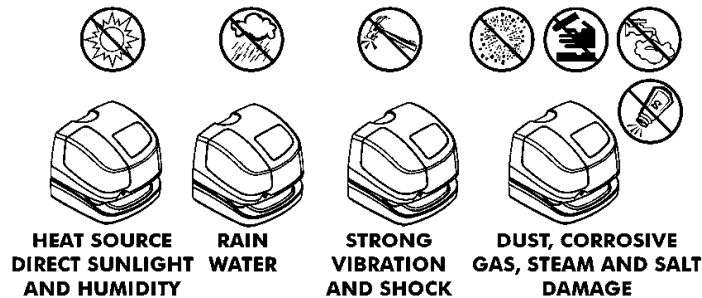

1. Remove the Cover and then remove the Back Plate by pressing the tab on the bottom of the clock as shown in the right-hand figure.

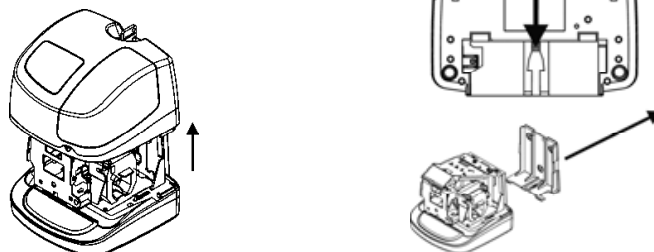

2. Using the Back Plate as a template, mark the lower mounting hole on the wall.
3. Mount the plate using a #10 wood screw (or equivalent) in the center mounting hole.
4. Level the Back Plate and mark the location of the two upper mounting holes. Secure to the wall using #10 wood screws (or equivalent).
5. Feed the cable of AC Power Adapter through one of the holes in the Back Plate.

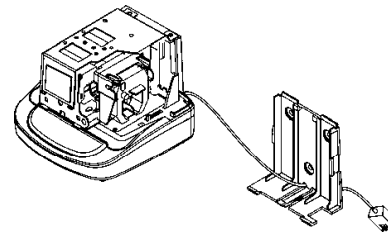
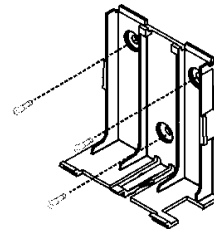

6. Align the clock with the two upper tabs on the back plate. Tilt the back of the clock upwards to fully insert the back plate tabs into the clock. Be careful not to pinch the power cord with the bracket.
7. Once the tabs are inserted, tilt the clock back down and push it against the wall. The tabs will snap into place.
8. Replace the cover and lock it in place using the supplied key.

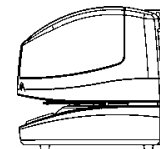
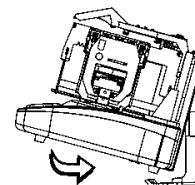
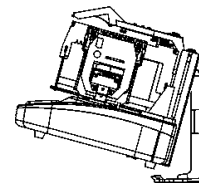

## Atomic Clock Feature

The Amano atomic clock receives time signals on long wave radio (60 kHz) from the National Institute of Standards and Technology (NIST) radio station WWVB, located in Fort Collins, Colorado, which is coupled with the atomic cesium clock in Boulder. The PIX-55 receives the WWVB time signal via its built-in antenna system. Your clock will try to find the signal on a daily basis.



The Atomic Time Synchronization Indicator in the LCD Display indicates the status of the signal. When you first receive the clock, it may be necessary to adjust the hour and minute. If your PIX-55 is located in an area that cannot receive the Atomic time signal, DO NOT be concerned, since the PIX-55 is able to accurately keep the time using its quartz mechanism (plus or minus three seconds per week).

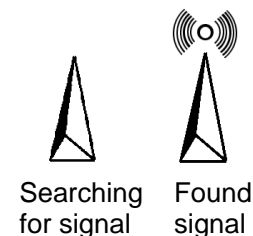

Please visit to <http://tf.nist.gov/stations/radioclocks.htm> for more information about how radio-controlled clocks work, where they work, and what to do when they don't work.

## Disabling or Enabling the Atomic Clock

By default, the Atomic Clock function is enabled. If you wish to disable the atomic clock synchronization, or if you wish to re-enable synchronization, please do the following:

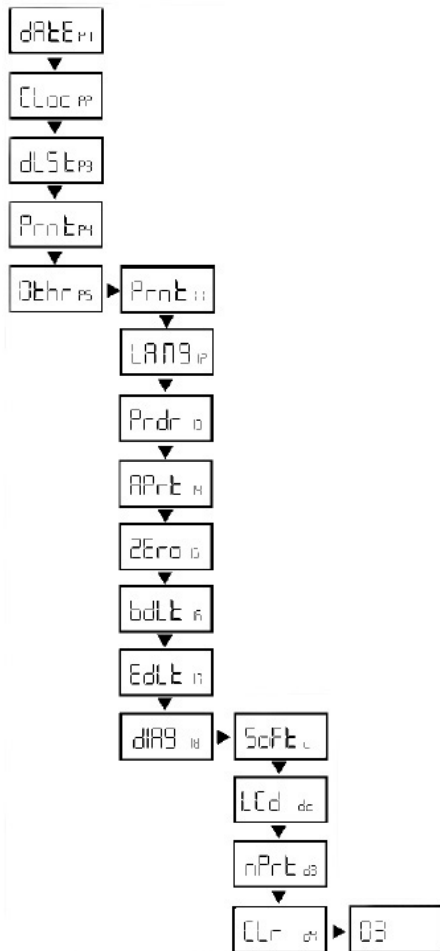

1. Press the **PROGRAM** button until **DATE P1** appears.
2. Press the **CHANGE** button until **00hr P5** flashes in the display. Press the **ENTER** button.
3. Press the **CHANGE** button until **diag P8** flashes in the display. Press the **ENTER** button.
4. Press the **CHANGE** button until **CLR d4** flashes in the display. Press the **ENTER** button.
5. Press the **CHANGE** button until the last digit of the code is the number 3 (to disable atomic clock) or the number 4 (to enable atomic clock).
6. Press **ENTER** to accept the entry. The display will move to the first digit of the code (0). Press **ENTER** to accept it. When the display flashes the correct code (03) for disable or (04) for enable, press **ENTER**.
7. Press the **PROGRAM** button to exit.

## Ribbon Cartridge Replacement

**Step 1.** Insert the clock key (required to unlock the cover), turn clockwise, lift up the cover (see figure), and remove for ribbon access. Locate the ribbon cradle.

**Note:** You **MUST** have the key to remove the cover for ribbon replacement.

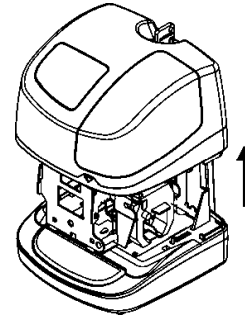

The Amano PIX-55 clock pictured to the right, shows a typical layout with the ribbon cartridge installed in the cradle.

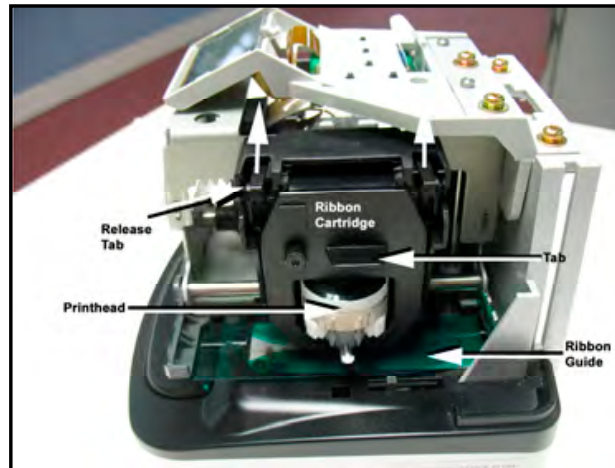

**Step 2.** Pull the two release tabs ("B") upward, and hold with index and middle fingers (see figure).

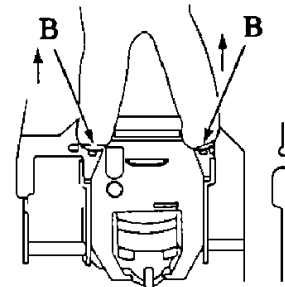

**Step 3.** While holding the release tabs in an upward position, grasp the tab on the ribbon cassette, and pull the ribbon cassette out of the cradle (see figure).

**Note:** If the print mechanism is down (a piece of paper could not be inserted), press the **RESET** button to move the carriage up. This will make the ribbon installation easier.

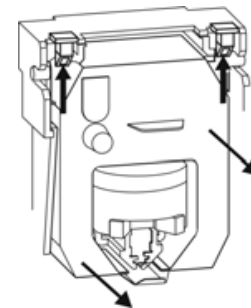

**Step 4.** Insert a new ribbon and be sure to mount it between the ribbon guide and the printer head as illustrated (see figure and arrows).

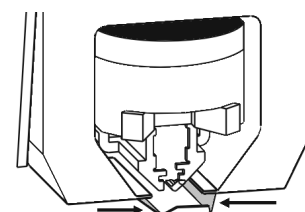

**Step 5.** Turn the knob on the cassette clockwise one turn to take up any slack in the ribbon (see figure).

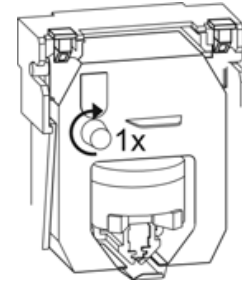

**Step 6.** Reset the INK indicator **E**  **F** by pressing the **CHANGE** and **ENTER** buttons at the same time.

**Step 7.** Stamp a card to check the printing quality and confirm that you have installed the ribbon properly.

**Step 8.** Replace the cover (locks automatically).



The PIX-55 ribbon cartridge in Black ink is:  
Amano Part No. **CE-315151** **Order now!**

The PIX-55 ribbon cartridge in Red ink is:  
Amano Part No. **YK-629671** **Order now!**

The PIX-55 ribbon cartridge in Green ink is:  
Amano Part No. **YK-629771** **Order now!**

These ribbon cartridges are normally good for approximately 6000 stamps, but they are supplied in sealed plastic bags to provide an average shelf life of 2 plus years.

The Amano Part number for a set of PIX-55 keys is **AJR-201150**



**Note** – A key is required to unlock the top cover which allows you access to the ribbon cartridge for replacement and/or the programming buttons.

When ordering parts and/or accessories, be sure to include your PIX-55 model number.

## Error Messages

In the event of an error, a message will appear in the display. The possible error messages are listed in the following table along with their probable causes and solutions.



**Note** – An error message can be possibly cleared by pressing the “**Reset**” button. The Reset button is located on the bottom right back corner of clock. It is a small button inside the hole (see figure). You **DO NOT** have to remove the back plate to press the Reset button. There is a cutout that allows access to it even if the clock is still mounted on the wall. However, you will have to remove the top cover to access the programming buttons should you have to reprogram the clock due to an error. To remove the cover, insert the key provided (Amano Part # AJR-201150), turn clockwise and lift to remove.

For error messages Pr<sub>1</sub> E1 through Pr<sub>1</sub> E<sub>r</sub>, unplug the clock before checking to see that the carriage is not stuck or jammed. Also, check to see that the ribbon cables are in good condition. After clearing any jams, plug the clock back in. Contact us at 1-800-253-9836 if you need assistance.

The dL<sub>1</sub> error message signifies that an attempt was made to get into the Program mode during the Daylight Saving changeover one-hour lockout. Wait one hour and you will be able to program the clock.

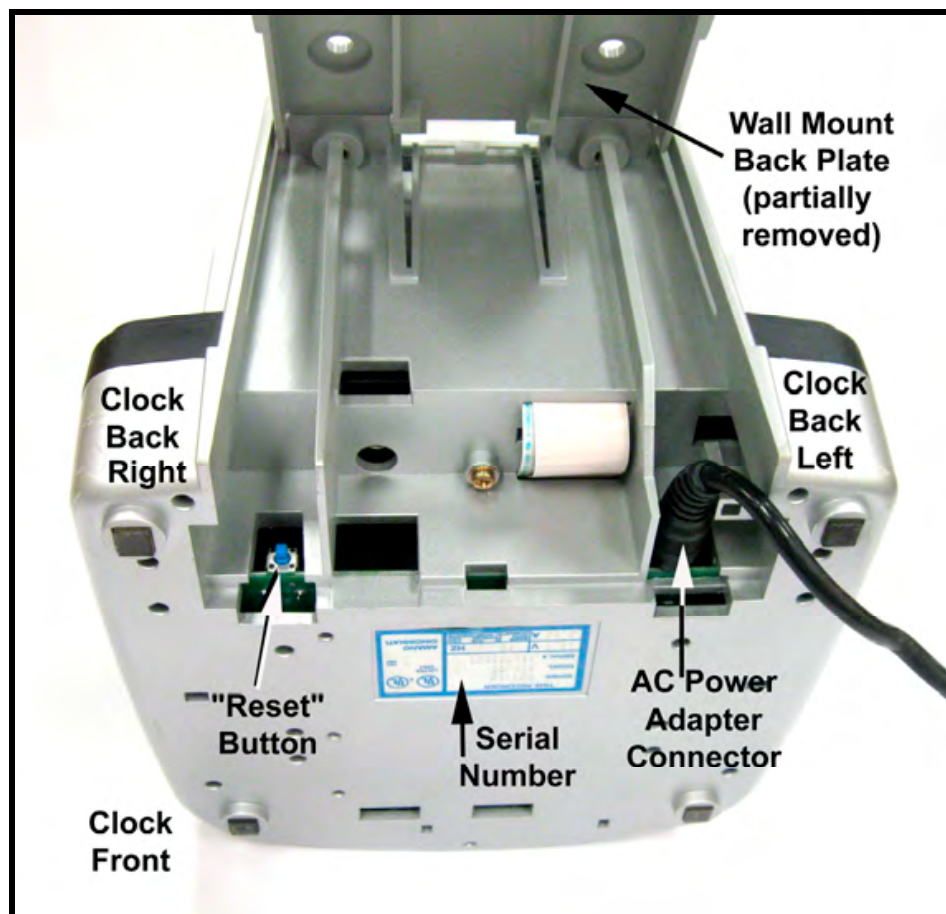

Figure: PIX-55 Bottom View

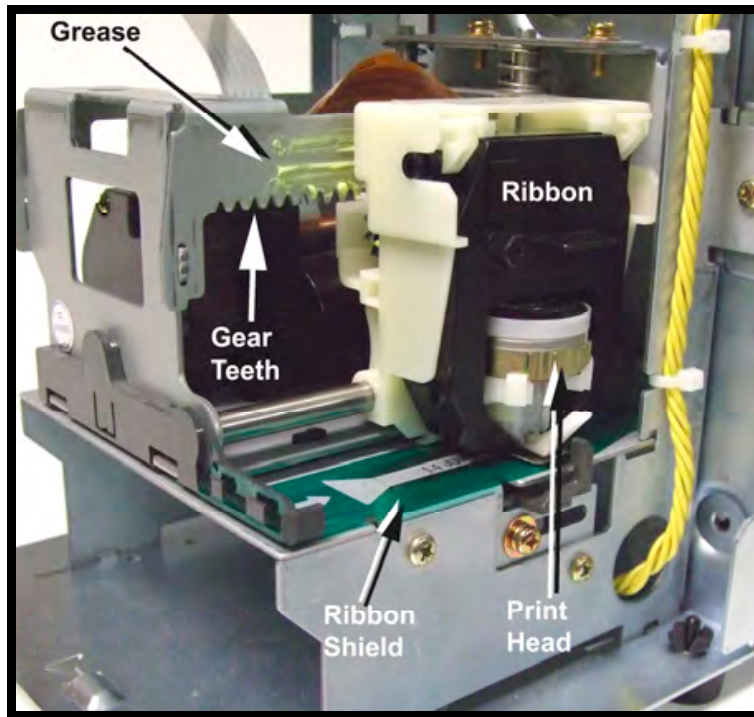

Table: Error Messages

Error Message	Cause	Solution
E1 Prt	General Print Error.	Unlock cover and remove. Press the <b>Reset</b> button (see <i>above figure</i> ). If the error clears, try to stamp a card. If the unit stamps without having the error message come up again replace the cover and lock. The configuration is still programmed in the clock.
E2 Prt	Home Sensor Motor, Carriage Stuck.	Unlock cover and remove. Set PIX-55 on side with the ribbon side up. Press the <b>Reset</b> button to reset the printer carriage and blow air into the printer platen to remove or dislodge jammed objects (i.e., staples).
E3 Prt	Timing Sensor, Carriage Stuck.	Unlock cover and remove. Set PIX-55 on side with the ribbon side up. Press the <b>Reset</b> button to reset the printer carriage and blow air into the printer platen to remove or dislodge jammed objects. If the error reoccurs, check the wires and cables to verify all are connected properly.
E3 Prt / E4 Prt	Home Sensor, Carriage Stuck.	Unlock cover and remove. Press the <b>Reset</b> button to reset the printer carriage and the time should reappear on the display. Try to stamp a card again so you can hear the machine attempting to stamp. If you hear that the assembly sounds sluggish or drags, Amano recommends that the frame be re-lubricated with either silicone or white lithium grease. See the following figure for location. (DO NOT use WD-40 as it will damage the plastic components).



**Note** – Print errors can be caused by the absence of grease on the printing carriage mechanism. If this occurs, the carriage mechanism may not slide smoothly. This movement restriction may cause the printer to display a print error and stop working. If this occurs, apply white silicone grease to the horizontal metal plate that the carriage mechanism slides against (see the following figure).



*Figure: Ribbon Carriage Grease*

Should you need further assistance in clearing an error message:

1. Visit our website at: <http://www.amano.com/time> or
2. Call us at: **1 (800) 253-9836**
  - Monday – Friday 8:00am – 5:00pm (EST)

## Clearing the Memory on the PIX-55 – “Prt er” Error Message

Before you begin, press the reset button on the bottom of the unit. The reset button is located in the back right corner on the bottom of the clock. (Inside an opening). The time must be visible on the display to be able to program the unit.

1. Press the **PROGRAM** button down for 2 seconds, then release. Your display will read “**dAtE P1**”
2. Press the **CHANGE** button 4 (four) times. Your display will read “**Othr P5**”
3. Press the **ENTER** button once. Your display will read “**Prtt 11**”
4. Press the **CHANGE** button 7 (seven) times. Your display will read “**dIA9 18**”
5. Press the **ENTER** button once. Your display will read “**SoFt d1**”
6. Press the **CHANGE** button 3 (three) times. Your display will read “**CLr d4**”



7. Press the **ENTER** button once. Your display will read “00”. The zero on the right should be flashing.
8. Press the **CHANGE** button 2 (two) times. The display will read “02”.
9. Press the **ENTER** button once. The left zero should now be flashing.
10. Press the **CHANGE** button 3 (three) times. The display will read “32”.
11. Press the **ENTER** button 2 (two) times. The display will now read “dIA9 18”
12. Press the **PROGRAM** button once to exit from programming.

The programmable memory in your PIX-55 has now been reset to the factory default. Please insert a piece of media to conduct a test print. If the error message does not come back, you can now reprogram your unit to the current date and time. However, if the error message returns, please call 800-253-9836 for additional assistance.

## Cleaning

Do not use any chemical solvents or oils to clean or lubricate your PIX-55. This will damage your clock. To clean the inside of your clock, simply blow it out with air.

## Resetting Clock After Extended Loss of Power

If there has been a power interruption of duration sufficient to drain the internal lithium battery, the date setting, the clock setting and the Daylight Saving Time setting will each need to be reset.

## NOTES



# AMANO®

*Corporate Headquarters*  
140 Harrison Avenue, Roseland, NJ 07068-1239  
(800) 526-2559

[www.amano.com/time](http://www.amano.com/time)