WS-12 Wireless 8 Channel Professional Weather Station with Temperature Spectrum Color Changing Backlight User Manual



Table of Contents

1	Introduction.....	2
2	Warnings	2
3	Quick Start Guide.....	3
4	Getting Started	3
4.1	Parts List.....	3
4.2	Recommend Tools	5
4.3	Anemometer Assembly Sensor Set Up.....	5
4.4	Rain Gauge Assembly Set Up	6
4.5	Thermo-Hygrometer Sensor Set Up.....	8
4.6	Display Console	10
4.6.1	Display Console Layout.....	10
4.6.2	Display Console Set Up	11
4.6.3	Sensor Operation Verification	13
5	Weather Station Installation	14
5.1	Pre-Installation Checkout	14
5.2	Site Survey	14
5.3	Best Practices for Wireless Communication	14
6	Final Sensor Installation.....	15
6.1	Anemometer Installation	15
6.2	Rain Gauge Installation	17
6.3	Thermo-Hygrometer Installation.....	19
7	Console Operation.....	19
7.1	Quick Display Mode	19
7.2	Set (Program) Mode	20
7.3	Restore Factory Default.....	23
7.4	Channel Selection.....	23
7.5	Sensor Search Mode.....	23
7.6	History Graph Mode.....	23
7.7	Reset Min/Max record.....	24
7.8	Snooze Mode.....	24
7.9	Backlight Mode	24

7.10	Adjustment or Calibration	25
7.10.1	Temperature Calibration.....	26
7.10.2	Humidity Calibration	26
7.10.3	Wind Speed, Rainfall and Barometric Pressure Calibration	26
8	Alarm Mode.....	28
8.1	Alarm Operation.....	28
8.2	Viewing the High and Low Alarms	29
8.3	Setting the Alarms	29
8.4	Alarm and Command Key Beeper ON/OFF Mode	30
9	Other Console Features	30
9.1	Feels Like Temperature	30
9.2	Moon Phase	32
9.3	Personalizing Color Ranges	32
9.4	Low Battery Icon.....	32
10	Glossary of Terms.....	33
11	Specifications	33
11.1	Wireless Specifications	33
11.2	Measurement Specifications	34
11.3	Power Consumption	34
12	Troubleshooting Guide.....	34
13	Maintenance	36
14	Accessories	36
15	Liability Disclaimer	36
16	FCC Statement	37
17	Warranty Information.....	38

1 Introduction

Thank you for your purchase of the WS-12 Wireless 8 Channel Professional Weather Station with Temperature Spectrum Color Changing Backlight. The following user guide provides step by step instructions for installation, operation and troubleshooting. To download the latest manual and additional troubleshooting tips, please visit:

<http://ambientweather.wikispaces.com/ws12>

2 Warnings

 **Warning:** Any metal object may attract a lightning strike, including your weather station mounting pole. Never install the weather station in a storm.

 **Warning:** Installing your weather station in a high location may result in injury or death. Perform as much of the initial check out and operation.



3 Quick Start Guide





Step	Description	Section
1	Assemble and power up the sensors	4.1- 4.5
2	Power up the display console and synchronize with wind sensor, rain sensor and thermo-hygrometer sensor(s)	4.6
3	Mount the sensors	6
4	Set date and time on console	7.2
5	Calibrate the relative or sea-level pressure (barometer)	7.10.3

4 Getting Started

The WS-12 weather station consists of a display console (receiver), a sensor array with thermo-hygrometer, rain gauge, wind sensor, and mounting hardware.

4.1 Parts List

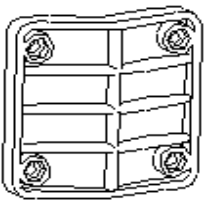
QTY	Item	Image
1	Display Console Frame Dimensions (LxHxW):7.7X1.3X5.4 in LCD Dimensions (LxW): 5.1 x 4.3 in	
1	Thermo-hygrometer transmitter (FT007TH) Dimensions (LxHxW): 4.5 x 2.0 x 0.75in	
1	Rain Gauge (WS-12-RG) Dimensions: 8 1/4" x 7 3/4" x 5" (5" diameter)	

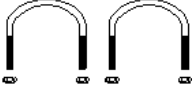
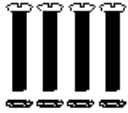
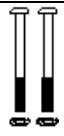
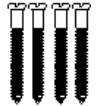
QTY	Item	Image
1	Anemometer (WS-12-WV) Dimensions: 3 ¼ x 6 x 8 ½”	
1	Anemometer Mounting Bracket (with pole insert) Dimensions: 3 x 4 x 1 ½”	
1	Anemometer Mounting Bracket Back Plate (pole mount) Dimensions: 3 x 3 x 1 ”	
1	Anemometer Pole Dimensions: 12 x 1½ x 1”	
2	Pole mounting U-bolt / nuts (M5)	
4	Pole mounting nuts (M5) / bolts (Ø5)	
2	Pole mounting nuts (M3) / bolts (Ø3)	
4	Tapping screws	



QTY	Item	Image
1	Manual	
1	Power Adapter	

Figure 1

4.2 Recommend Tools

- Precision screwdriver (for small Phillips screws)
- Compass or GPS (for wind direction calibration)
- Adjustable Wrench
- Hammer and nail for hanging remote thermo-hygrometer transmitter.

4.3 Anemometer Assembly Sensor Set Up

The anemometer assembly consists of the wind cups, wind vane, solar panel, bubble level, sensor mounting bracket and mounting foot.

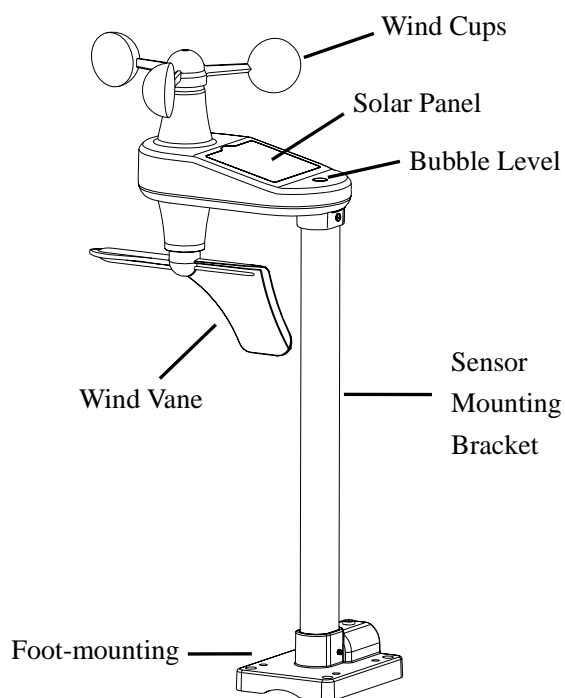

Figure 2

Locate the battery door on the anemometer transmitter, push and open the battery compartment, as shown in

Figure 3.

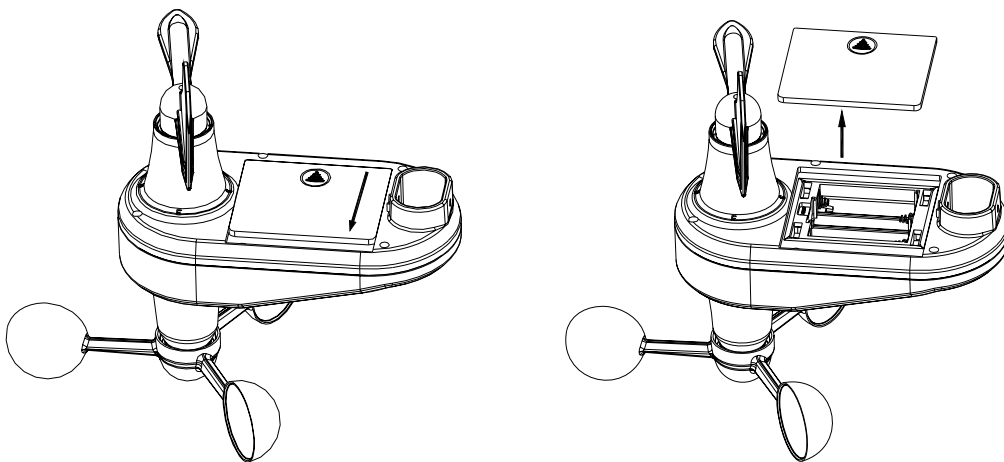



Figure 3

Insert four batteries into the battery compartment, then press the reset button, as shown in Figure 4.

 **Note:** Use high quality alkaline batteries, which have an operational temperature range of -4 to 140 °F. Use Energizer e2 Lithium batteries for low temperature installation, which have an operational temperature range of -40 to 140 °F. Do not use rechargeable batteries. They have a lower operating voltage and discharge faster than non-rechargeable batteries, and will result in short transmission ranges.

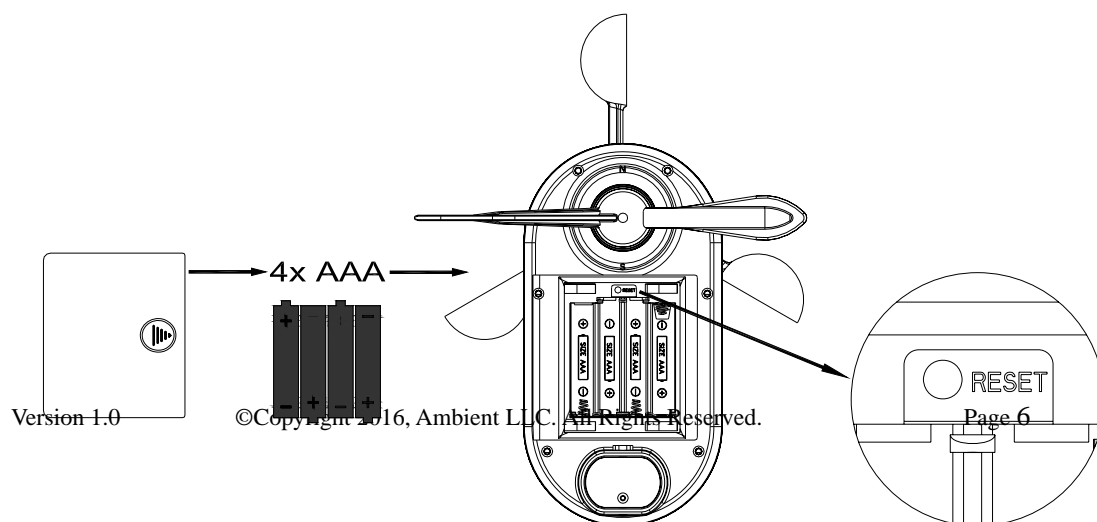

Figure 4

4.4 Rain Gauge Assembly Set Up

The rain gauge consists of the rain gauge funnel, base, and drawer filter, as shown in Figure 5.

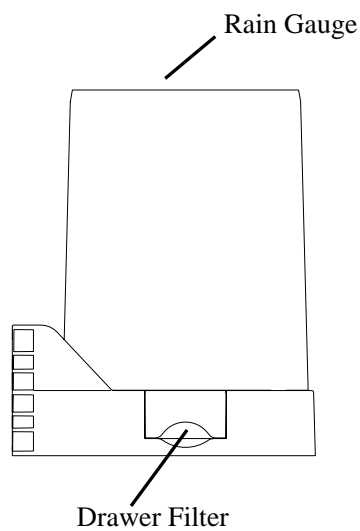

Figure 5

Rotate and detach the rain gauge funnel, as shown in Figure 6.

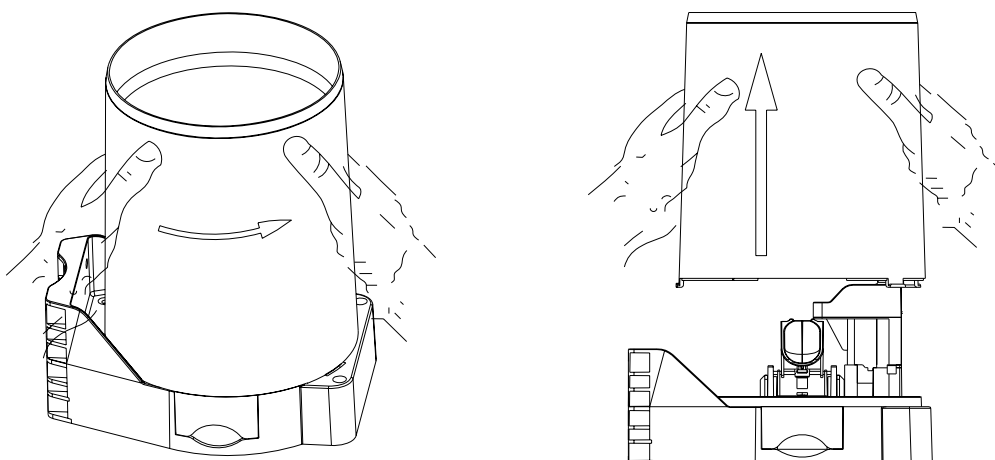
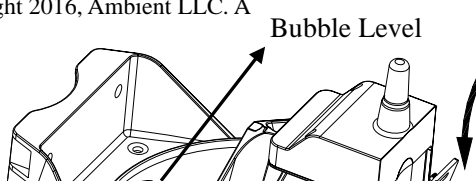

Figure 6

Locate the battery door on the rain gauge transmitter, pull out the battery compartment, as shown



in

Figure 7.

Figure 7

4.5 Thermo-Hygrometer Sensor Set Up

Remove the battery door on the back of the sensor by removing the set screw, as shown in Figure 8.

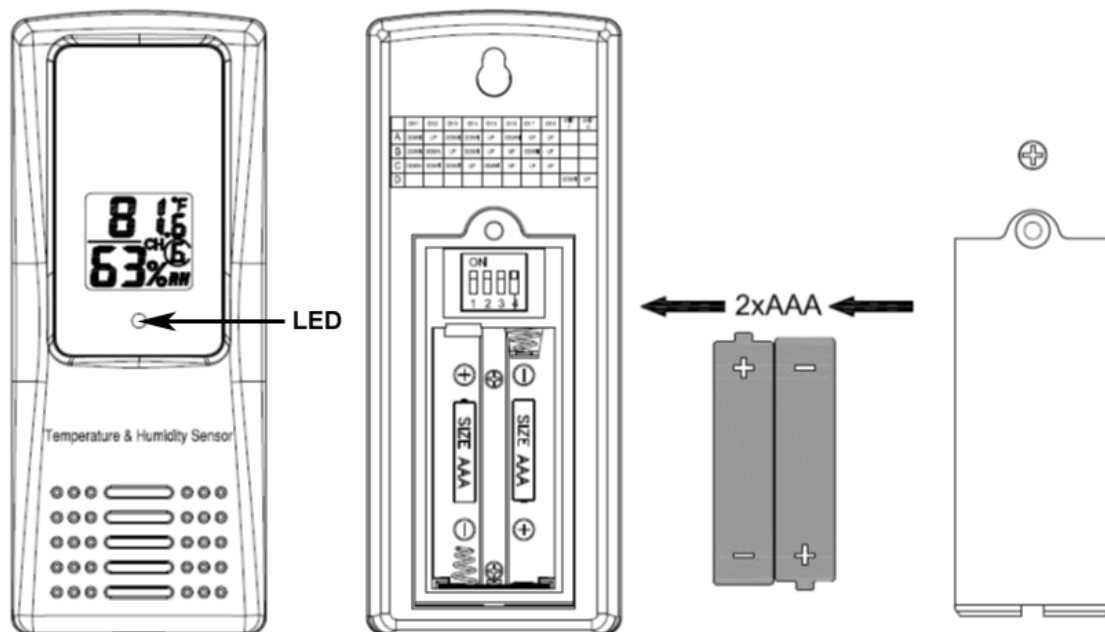

Figure 8

- BEFORE** inserting the batteries, locate the dip switches on the inside cover of the lid of the transmitter.

Figure 9 displays all four switches in the OFF position (factory default setting).

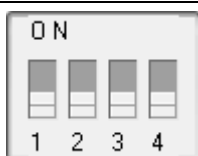

Figure 9

Channel Number: The WS-12 supports up to eight transmitters. To set each channel number (the default is Channel 1), change Dip Switches 1, 2 and 3, as referenced in Table 1.

Temperature Units of Measure: To change the transmitter display units of measure (°F vs. °C), change Dip Switch 4, as referenced in Table 1.

DIP SWITCH				FUNCTION
1	2	3	4	
DOWN	DOWN	DOWN	---	Channel 1
DOWN	DOWN	UP	---	Channel 2
DOWN	UP	DOWN	---	Channel 3
DOWN	UP	UP	---	Channel 4
UP	DOWN	DOWN	---	Channel 5
UP	DOWN	UP	---	Channel 6
UP	UP	DOWN	---	Channel 7
UP	UP	UP	---	Channel 8
---	---	---	DOWN	°F
---	---	---	UP	°C

Table 1

2. Insert two AAA batteries.
3. After inserting the batteries, the remote sensor LED indicator will light for 4 seconds, and then flash once per 60 seconds thereafter. Each time it flashes, the sensor is transmitting data.
4. Verify the correct channel number (CH) and temperature units of measure (°F vs. °C) are on the display, as shown in Figure 10.

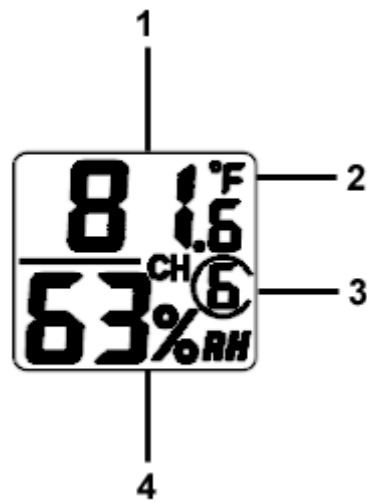

Figure 10

- (1) temperature
- (2) temperature units (°F vs. °C)
- (3) channel number
- (4) relative humidity

5. Close the battery door. Make sure the gasket (around the battery compartment) is properly seated in its trace prior to closing the door. Tighten the set screw.

4.6 Display Console

4.6.1 Display Console Layout

The display console layout is shown in Figure 11.

 Note: The following illustration shows the full segment LCD display for description purposes only and will not appear like this during normal operation.

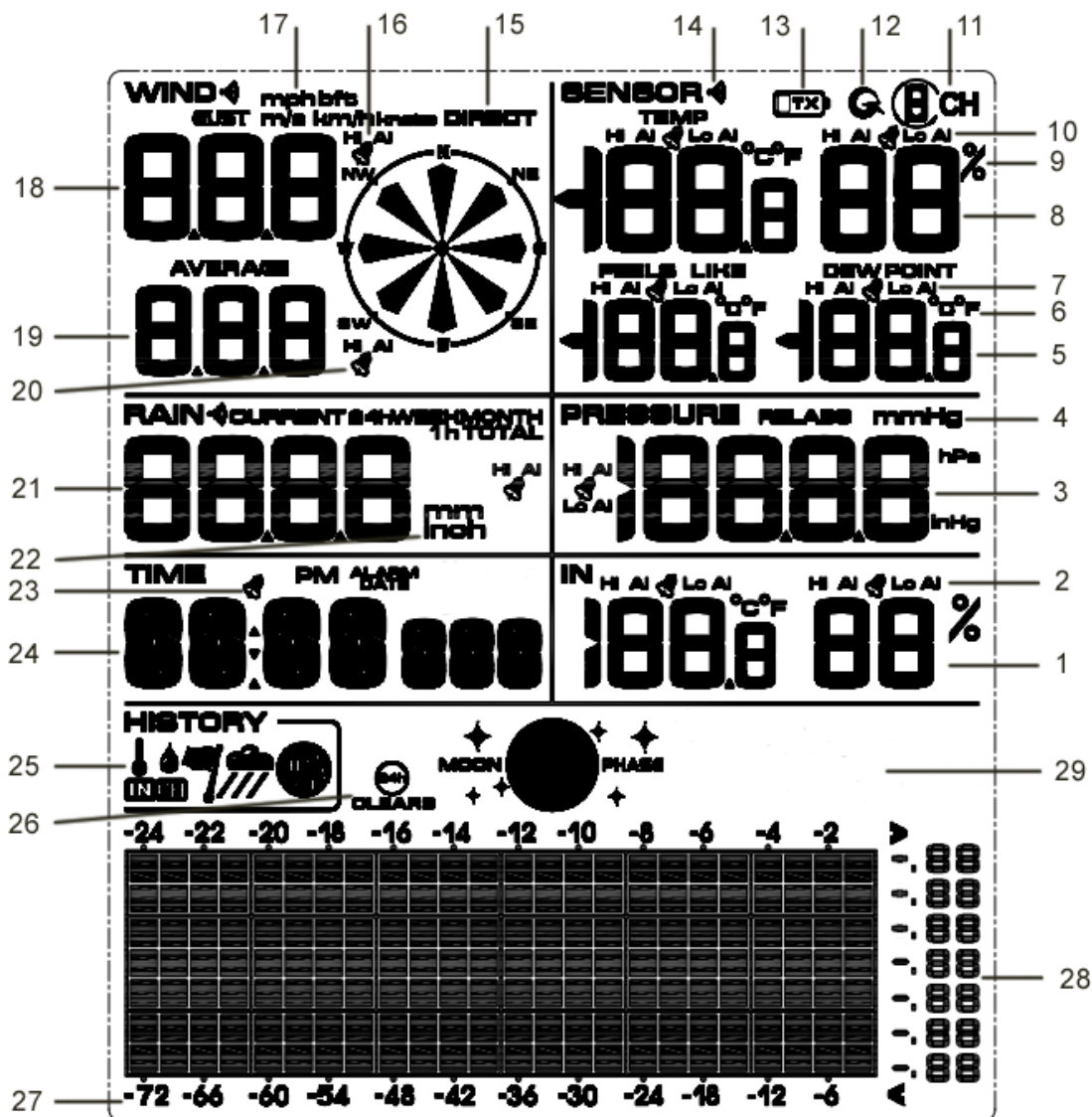



Figure 11

- | | |
|---|--|
| <ul style="list-style-type: none"> 1. Indoor temperature and humidity display 2. Indoor temperature and humidity HI/LO alarm icon 3. Pressure (REL and ABS) display 4. Pressure units of measure 5. Feels like and dew point display 6. Temperature units (°F or °C) 7. Feels like and dew point HI/Lo alarm icon 8. Outdoor temperature and humidity display 9. Humidity units of measure (%) 10. Outdoor temperature and humidity HI/LO alarm icon 11. Channel 1-8 indicator 12. Scroll mode indicator 13. Low power indicator 14. Signal search icon | <ul style="list-style-type: none"> 15. Wind direction 16. Wind gust HI alarm icon 17. Wind speed units of measure 18. Wind gust display 19. Wind speed average display 20. Wind speed average HI alarm icon 21. Rainfall display (1h, 24h, week, month, total) 22. Rainfall units of measure 23. Time alarm icon 24. Time and date 25. Temperature, humidity, wind speed, rainfall and pressure history display icon 26. Min/Max reset for 24h 27. Time format of history graph (24h or 72h) 28. Temperature, humidity, wind speed, rainfall and pressure variation in past 24h or 72h 29. Moon phase |
|---|--|

4.6.2 Display Console Set Up

 **Note:** Power up the rain gauge, anemometer and thermos-hygrometer sensors first before powering up the console. If you power up the console first, you will need to resynchronize the sensors.

Make certain the weather station sensors are at least 10' away from the console and within 100' of the console. If the weather station is too close or too far away, it may not receive a proper signal. If you have more than one thermo-hygrometer transmitter, make sure they are all powered up and transmitting on different channels.

1. Remove the battery door on the back of the console, as shown in Figure 12.
2. Insert four AA batteries in the back of the display console. The display will beep once and all of the LCD segments will light up for a few seconds to verify all segments are operating properly. The console will cycle through a spectrum of colors.

 **Note:** The character contrast is best viewed from a slightly elevated angle.

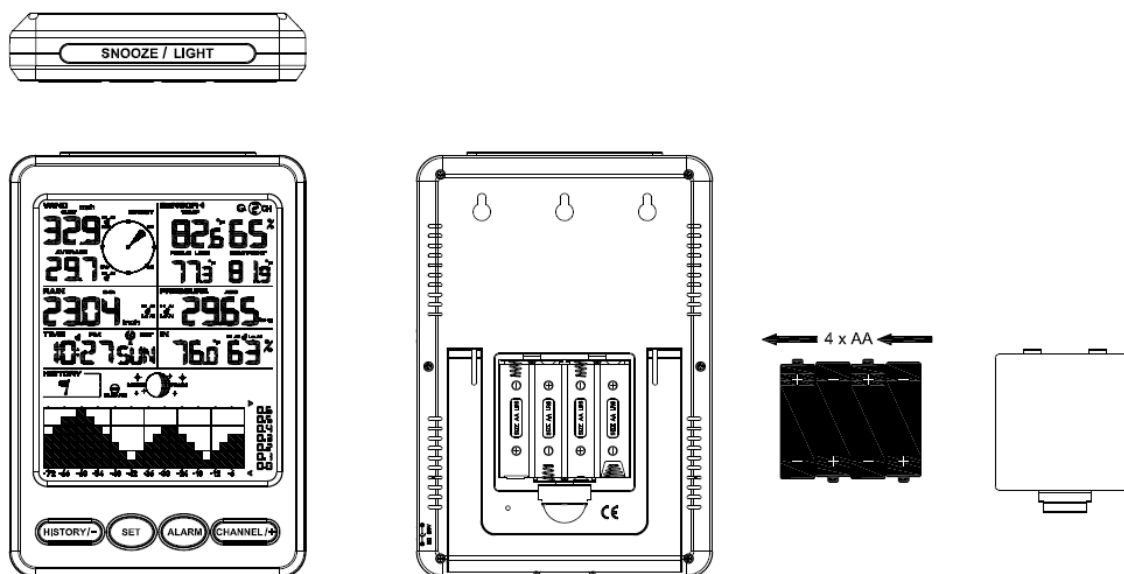

Figure 12

3. Replace the battery door, and fold out the desk stand and place the console in the upright position.

The console will instantly display indoor temperature, humidity, pressure, moon phase and time. The wind speed, wind gust, wind direction, rain, outdoor temperature and humidity will update on the display within a few minutes. Do not Press any menu buttons until the outside transmitter reports in, otherwise the outdoor sensor search mode will be terminated. When the outdoor transmitter data has been received, the console will automatically switch to the normal mode from which all further settings can be performed.

While in the search mode, the remote search icon  will be constantly displayed.

If you have more than one thermo-hygrometer sensor (up to eight thermo-hygrometer sensors are supported), the display will automatically toggle between sensors until all sensors have reported in.

If it does not update, please reference the troubleshooting guide in Section 12.

 **Note:** The power adapter is intended to be correctly oriented in a vertical or floor mounted position. The prongs are not designed to hold the plug in place if it is plugged into a ceiling, under-the-table or cabinet outlet.

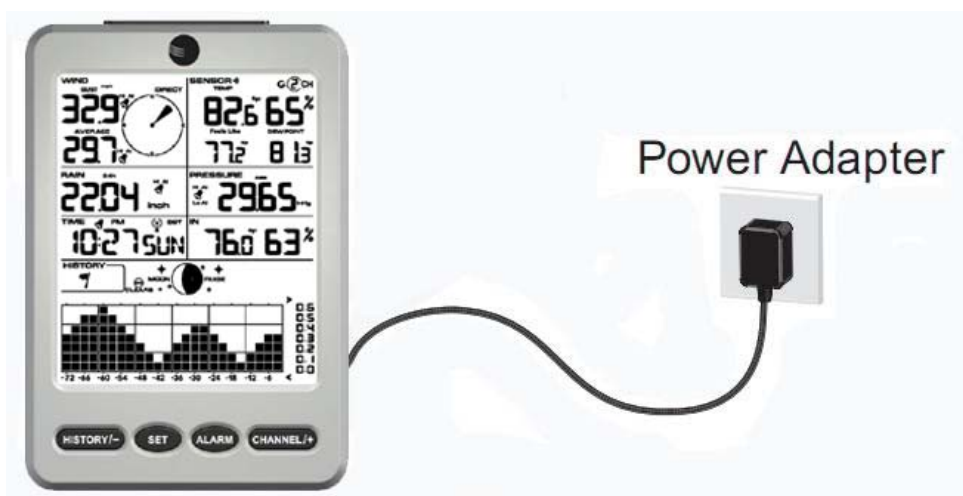



Figure 13

 **Note:** If the power adapter is plugged in, **AC ON** will display in the time area for three seconds when powered up. Conversely, if the power adapter is not plugged in, **AC OFF** will be displayed.

4.6.3 Sensor Operation Verification

The following steps verify proper operation of the sensors prior to installing the sensor array.

- Verify proper operation of the rain gauge. Tip the sensor array back and forth several times. You should hear a “clicking” sound within the rain gauge. Verify the rain reading on the display console is not reading 0.00. Each “click” represents 0.01 inches of rainfall.
- Verify proper operating of the wind speed. Rotate the wind cups manually or with a constant speed fan. Verify the wind speed is not reading 0.0.
- Verify proper operation of the indoor and outdoor temperature. Verify the indoor and outdoor temperature match closely with the console and sensor array in the same location (about 10’ apart). The worst case sensor accuracy should be within 4°F worst case (the accuracy is $\pm 2^\circ\text{F}$). Allow about 30 minutes for both sensors to stabilize.
- Verify proper operation of the indoor and outdoor humidity. Verify the indoor and outdoor humidity match closely with the console and sensor array in the same location (about 10’ apart). The worst case sensor accuracy should be within 10% (the accuracy is $\pm 5\%$). Allow about 30 minutes for both sensors to stabilize.

5 Weather Station Installation

5.1 Pre-Installation Checkout

Before installing your weather station in the permanent location, we recommend operating the weather station for one week in a temporary location with easy access. This will allow you to check out all of the functions, insure proper operation, and familiarize you with the weather station and calibration procedures. This will also allow you to test the wireless range of the weather station.

5.2 Site Survey

Perform a site survey before installing the weather station. Consider the following:

1. You must clean the rain gauge every few months and change the rechargeable batteries every 2-3 years. Provide easy access to the rain gauge.
2. Avoid radiant heat transfer from buildings and structures. In general, install the thermos-hygrometer in a shaded area on the north side of a structure.
3. Avoid wind obstructions. The rule of thumb is to install the anemometer at least four times the distance of the height of the tallest obstruction. For example, if the building is 20' tall, and the mounting pole is 6' tall, install $4 \times (20 - 6) = 56'$ away.
4. Wireless Range. The radio communication between receiver and transmitter in an open field can reach a distance of up to 300 feet, providing there are no interfering obstacles such as buildings, trees, vehicles, high voltage lines. Wireless signals will not penetrate metal buildings. Under most conditions, the maximum wireless range is 100'.
5. Radio interference such as PCs, radios or TV sets can, in the worst case, entirely cut off radio communication. Please take this into consideration when choosing console or mounting locations. Make sure your display console is at least five feet away from any electronic device to avoid interference.
6. Visit Ambient Weather Mounting Solutions for assistance and ideas for mounting your weather station:
<http://www.ambientweather.com/amwemoso.html>

5.3 Best Practices for Wireless Communication

Wireless communication is susceptible to interference, distance, walls and metal barriers. We recommend the following best practices for trouble free wireless communication.

1. **Electro-Magnetic Interference (EMI).** Keep the console several feet away from computer monitors and TVs.
2. **Radio Frequency Interference (RFI).** If you have other 433 MHz devices and communication is intermittent, try turning off these other devices for troubleshooting purposes. You may need to relocate the transmitters or receivers to avoid intermittent communication.
3. **Line of Sight Rating.** This device is rated at 300feet line of sight (no interference, barriers or walls) but typically you will get 100feet maximum under most real-world installations, which include passing through barriers or walls.
4. **Metal Barriers.** Radio frequency will not pass through metal barriers such as aluminum siding. If you have metal siding, align the remote and console through a window to get a clear line of sight. The following is a table of reception loss vs. the transmission medium. Each “wall” orobstruction decreases the transmission range by the factor shown below.

Medium	RF Signal Strength Reduction
Glass (untreated)	5-15%
Plastics	10-15%
Wood	10-40%
Brick	10-40%
Concrete	40-80%
Metal	90-100%

6 Final Sensor Installation

6.1 Anemometer Installation

Prior to installation, you will need to calibrate the wind direction. There is a “S” indicator on the wind vane that indicates South, as shown in Figure . Align this “S” marker in the direction of South.

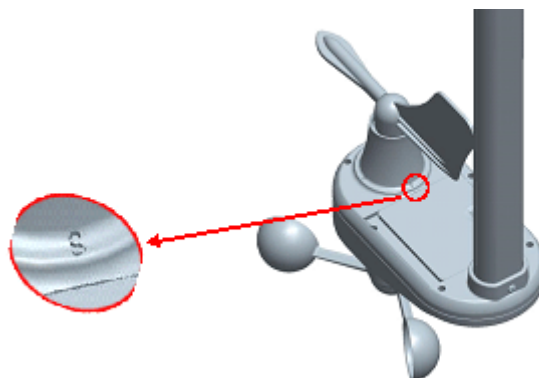

Figure 14

Fasten the wind transmitter to mounting pole brackets with foot-mounting, two $\text{\O}3$ bolts and M3

nuts, as shown in Figure 13.

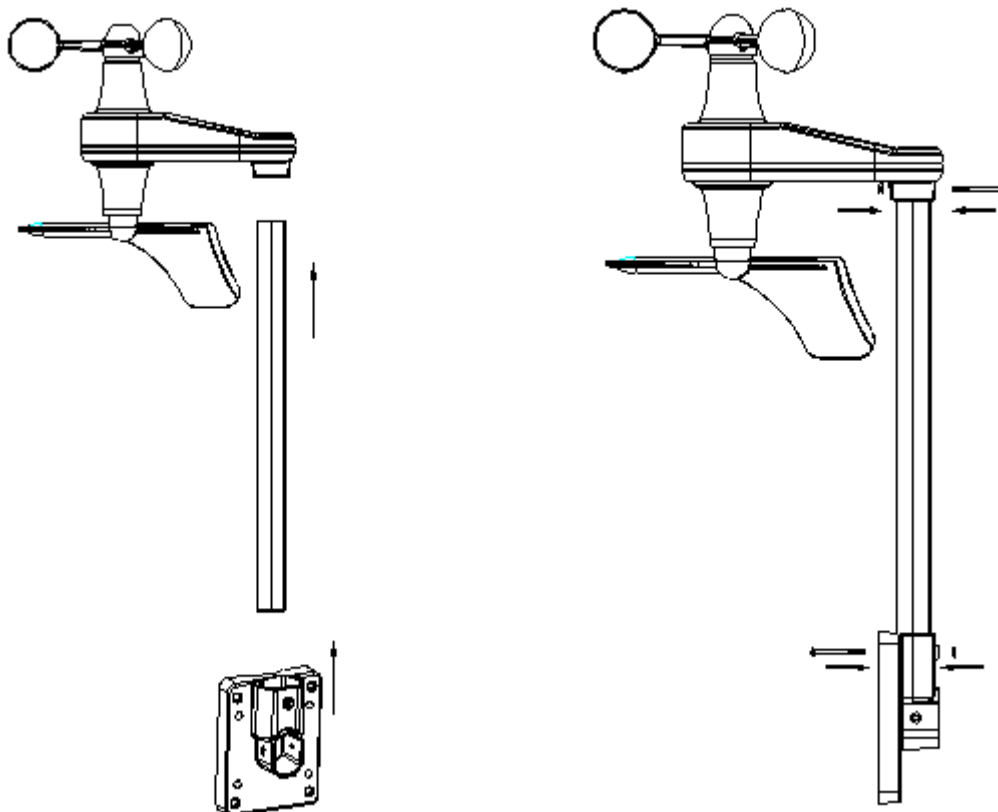

Figure 13

Tighten the included mounting pole to your mounting pole (purchased separately) with the four $\text{\O}5$

Bolts and M5 Nuts assembly, or fix on the wall with four tapping screws, as shown in Figure 14.

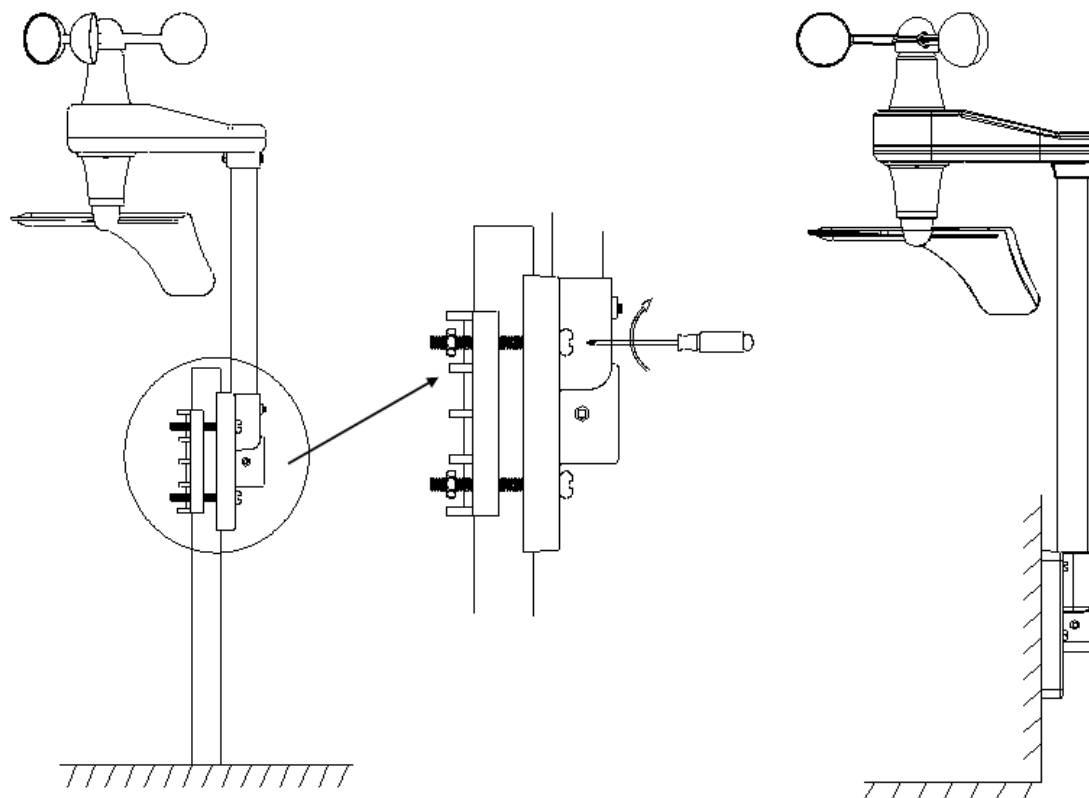

Figure 14

6.2 Rain Gauge Installation

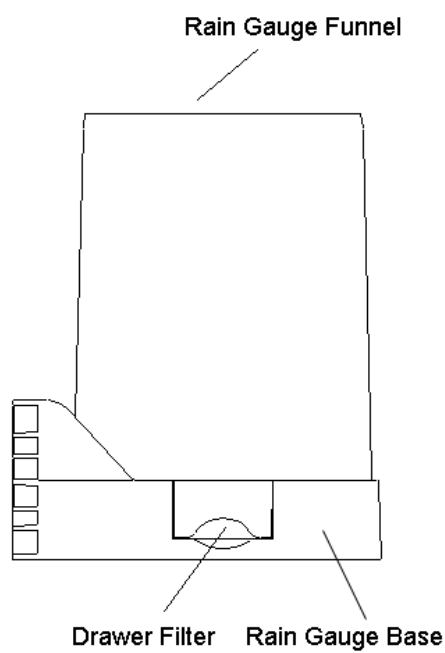

Figure 15

Remove the rain gauge funnel from the base prior to installation by rotating the counter clockwise until the tabs on the base and the funnel align, then pulling upwards.

Fasten the rain gauge to the mounting pole, as shown in Figure 16.

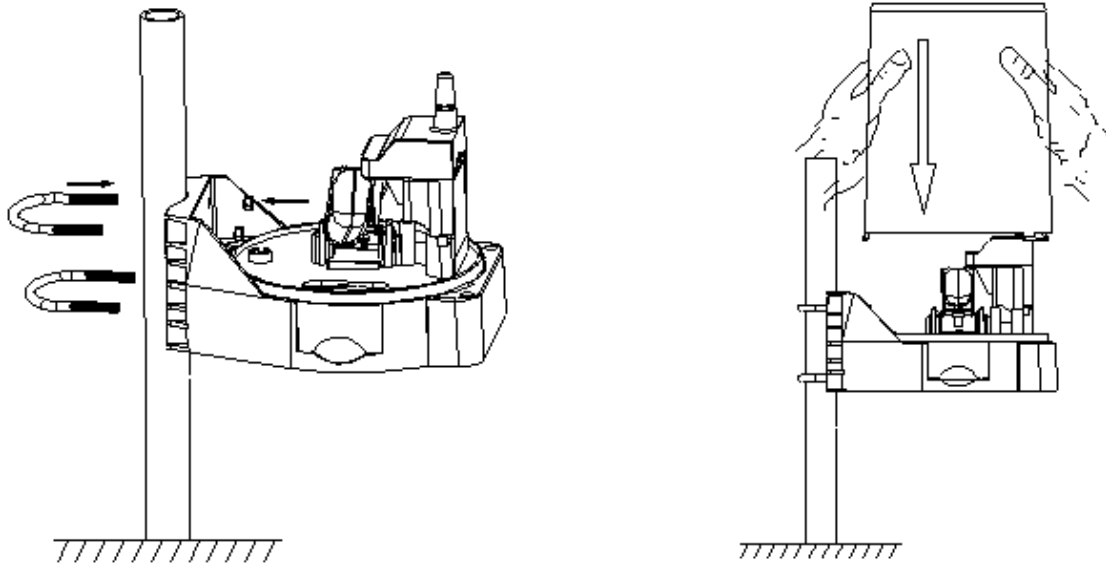

Figure 16

Tighten the rain gauge to your mounting pole or bracket with two U-bolts and four M5 nuts , or fix on a horizontal surface with the four tapping screws, as shown in Figure 17.

Reattach the funnel by aligning the tabs on the funnel and base, and rotate clockwise.

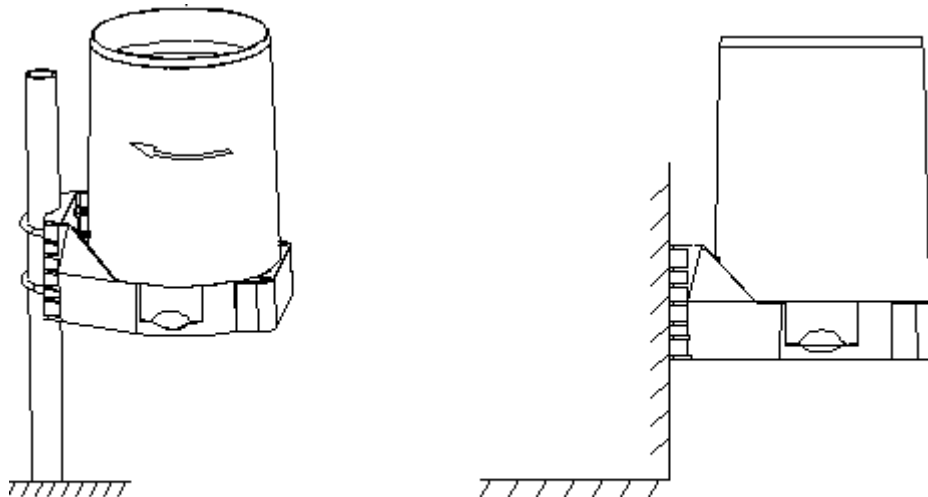

Figure 17

6.3 Thermo-Hygrometer Installation

It is recommended you mount the remote sensor outside in a shaded area. A north facing wall is preferred because it is in the shade most of the day. Direct sunlight and radiant heat sources will result in inaccurate temperature readings. Although the sensor is water resistant, it is best to mount in a well protected area, such as under an eave. Use a screw or nail (not included) to affix the remote sensor to the wall, as shown in Figure 0.

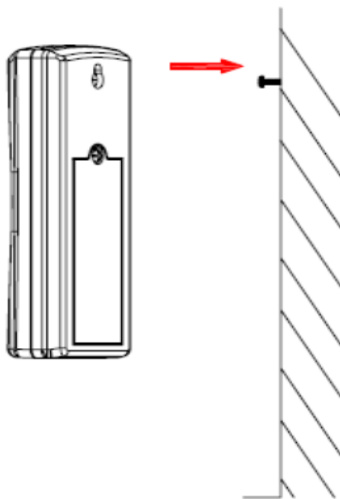



Figure 20

7 Console Operation

 Note: The console has five operational keys: **HISTORY/-** key, **SET** key, **ALARM** key, **CHANNEL/+** and **SNOOZE/LIGHT** key.

7.1 Quick Display Mode

 **Note:** To exit the Quick Display Mode at any time, press the **SNOOZE/LIGHT** button on the top of the display console.

While in Normal Mode, press (do not hold) the **SET** key to enter the Quick Display Mode as follows:

- once for time, time/week and date,
- twice for rainfall.
- three times for pressure.
- four times for 72h or 24h graph record

1. **Time, Time/Week and Date.** Press the **CHANNEL/+** or **HISTORY/-** key to toggle between time, time/week and date.

2. **Rainfall.** Press the **CHANNEL/+** or **HISTORY/-** key to toggle between 1h, 24h, week, month and total.
3. **Absolute Pressure and Relative Pressure** Press the **CHANNEL/+** or **HISTORY/-** key to toggle between absolute pressure and relative pressure.
4. **72h or 24h Graph Record.** Press the **CHANNEL/+** or **HISTORY/-** key to toggle between the last -72 hours or -24 hours record time. Each bar represents the corresponding data and time for wind speed, rainfall, pressure, temperature or humidity.(default is -72 hours)

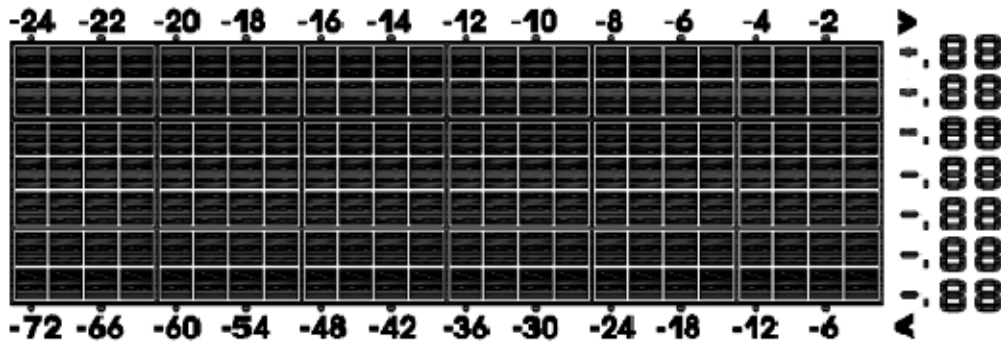





Figure 21

 **Note:** The graph displays hours on the horizontal or x-axis (the most recent data to the right of the graph). For example, 0h is the current data and -12 is 12 hours ago. The vertical axis or y-axis auto-scales, displays the deviation from the current value (the most recent data will always display 0). For example, when temperature is displayed, if the bar displays 0.4, this represents 0.4 degrees higher than the current value.

7.2 Set (Program) Mode

While in Normal Mode, **press and hold** the **SET** key for at least three seconds to enter the Set Mode. The first setting will begin flashing. You can press the **SET** key again to skip any step, as defined below.

 **Note:** In the Set mode, press the [+] key or [-] key to change or scroll the value. Hold the [+] key or [-] key for three seconds to increase/decrease rapidly.

 **Note:** To exit the Set mode at any time, press the **SNOOZE/LIGHT** button on the top of the display console.

1. **12/24 Hour Format (default: 12h):** Press the **SET** key again to adjust the 12/24 hour format setting (FMT). Press the [+] key or [-] key to change between 12 hour and 24 hour format.
2. **Change Hour.** Press the **SET** key again to set the hour. Press the [+] key or [-] key to adjust the hour up or down. Note the PM icon is present during afternoon hours.
3. **Change Minute.** Press the **SET** key again to set the minute. Press the [+] key or [-] key to adjust the minute up or down.
4. **Date Format (default: MM-DD):** Press the **SET** key again to enter the day/month format

-
- mode. Press the [+] key to switch between MM-DD-YY, DD-MM-YY.
5. **Change Month.** Press the **SET** key again to set the calendar month. Press the [+] key or [-] key to adjust the calendar month.
 6. **Change Day.** Press the **SET** key again to set the calendar day. Press the [+] key or [-] key to adjust the calendar day.
 7. **Change Year.** Press the **SET** key again to set the calendar year. Press the [+] key or [-] key to adjust the calendar year.
 8. **Max/Min Clearing (default: ON).** Press the **SET** key again to set the max/min clearing mode (CLR). The Max/Min can be programmed to clear daily (at midnight) or manually. Press the [+] key or [-] key to switch between “Clears 24h” and Clears Manually.
 9. **Temperature Units of Measure (default: °F):** Press the **SET** key again to change the temperature units of measure (the **UNITSET** icon will be displayed). Press the [+] key or [-] key to switch between °F and °C units of measure.
 10. **Wind Speed Units of Measure (default: mph).** Press the **SET** key again to change the wind speed units of measure. Press the [+] key or [-] key to toggle the wind speed units between m/s, km/h, mph, knots or bft.
 11. **Rainfall Units of Measure (default: inch).** Press the **SET** key again to change the Rainfall units of measure. Press [+] key or [-] key to toggle the rainfall units between mm and inch.
 12. **Barometric Pressure Display Units (default: inHg).** Press the **SET** key again to change the pressure units of measure. Press the [+] key or [-] key to toggle the pressure units between mmhg, inHg or hPa.
 13. **Backlight Color Setting (default: Outdoors).** Press the **SET** key again to set the backlight color defined parameter (the **LED** icon will be displayed). Press [+] key or [-] key to toggle between **IN** (uses the indoor temperature to automatically display backlight color), **OUT** (uses the channel 1 temperature to automatically display backlight color) or **USE** (manually set your own backlight color to one of 11 choices).

The following section is based on the OUT, IN or USE setting selected.

13.1 **OUT** Backlight Color Setting (reference Figure 18).

13.2 **Outdoor Backlight Color Low (OUT default: 10):** Press the **SET** key again to change the lower range of the color changing backlight spectrum (the **LOWER** icon will be displayed). Press the [+] key or [-] key to adjust the low temperature limit.

13.3 **Indoor Backlight Color High (default: 100):** Press the **SET** key again to change the upper range of the color changing backlight spectrum (the **UPPER** icon will be displayed).

13.4 **IN** Backlight Color Setting (reference Figure 18).











13.5 **Indoor Backlight Color Low (IN default: 58):** Press the **SET** key again to change the lower range of the color changing backlight spectrum (the **LOWER** icon will be displayed). Press the [+] key or [-] key to adjust the low temperature limit.

13.6 **Indoor Backlight Color High (default: 85):** Press the **SET** key again to change the upper range of the color changing backlight spectrum (the **UPPER** icon will be displayed).

13.7 **USE** Backlight Color Setting (reference Figure 18).

13.8 **Backlight Color (USE)**: Press the **SET** key again to manually select the backlight color (the **COLOR** icon will be displayed). Press [+] key or [-] key to choose among 11 different colors.

The following table provides 11 different backlight colors for reference:

No.	Color (USE)	Colors	OUT Temp (°F)	IN Temp (°F)	Comments (Manually set maximum and minimum values)
0	Cold Purple		<10	<58	LOW
1	Fuchsia		10-20	58-61	Color Increment = (HI-LOW)/9
2	Purple		20-30	61-64	
3	Blue		30-40	64-67	
4	Aqua		40-50	67-70	
5	Dark Green		50-60	70-73	
6	Light Green		60-70	73-76	
7	Yellow		70-80	76-79	
8	Orange		80-90	79-82	
9	Red		90-100	82-85	
10	Red Hot		>100	>85	HI

 Note: This manual is not printed in color. To view the actual color chart, visit:
<http://site.ambientweatherstore.com/Manuals/WS-12.pdf>
to view the actual color.

 Note: Reference Section 9.3 to modify the color changes to best suit your comfort level and location.

Figure 18

14. **Backlight Contrast**: Press the **SET** key again to change the backlight brightness (the **BRIGHT** icon will be displayed). Press the [+] key or [-] key to adjust the backlight contrast from 1 (dim) to 8 (bright).

7.3 Restore Factory Default

To restore the console to factory default, press the **HISTORY/-** key while installing the batteries at the same time. Wait 3 seconds after installing the batteries to let go of the **HISTORY/-** key.

7.4 Channel Selection

Press the **CHANNEL/+** button to switch the display between remote sensors 1 through 8, and scroll mode . In scroll mode, all of the indoor and detected outdoor sensors will be displayed in five second intervals.

7.5 Sensor Search Mode

If a sensor loses communication, dashes (--.) will be displayed. If a specific channel is lost, press the **CH/+** button to display that channel prior to entering the search mode.

To reacquire the lost signal, press and hold the **CH/+** button for 3 seconds to enter the sensor search mode.

The icon **REG** will appear. You can synchronize one or all of individual sensors. Press the [+] or [-] key to toggle between the following sensors:

- **CH.** Synchronizes Channel 1-8 Sensors (dependent on which channel is displayed before entering the Sensor Search Mode*).
- **WIND.** Synchronizes Wind Sensor
- **RAIN.** Synchronizes Rain Sensor.
- **ALL.** Synchronizes All Sensors.
- **NOT.** Do nothing and exit the Sensor Search Mode.

After selecting one of the above options, press the **SET** key to relying, and the display will return to normal mode. **Do not press any buttons** until the synchronization is complete. The remote search icon  will display constantly for 3 minutes until the signal is reacquired.

7.6 History Graph Mode

The historical graph on the display changed to display the measured parameters.

In normal mode, press the **HISTORY/-** key to toggle between:

- the wind speed graph (the **WIND** icon is displayed)
- the rainfall graph (the **RAIN** icon is displayed)
- the barometer graph (the **BAROREL** icon is displayed)
- indoor temperature graph (the **TEMP-IN** icon is displayed)

- indoor humidity graph (the **HUMI-IN** icon is displayed)
- outdoor temperature graph (the **TEMPOUT** icon is displayed)
- outdoor humidity graph (the **HUMIOUT** icon is displayed)

 Note: The outdoor humidity and temperature graph will display the history graph of the current channel displayed.

7.7 Reset Min/Max record

 Note: If you own more than one thermo-hygrometer sensor, the minimum and maximum value of all channels will be cleared in the reset mode.

In normal mode, press (do not hold) the **ALARM** key, and the **MAX** icon will be displayed. Press the **HISTORY/-** key to view rainfall (1h, 24h, week or month) and pressure (ABS or REL) max value.

Next, press the **SET** key for three seconds to clear the rainfall, wind speed, wind gust, pressure, temperature and humidity maximum values. The maximum values will now display the current values.

Press the **ALARM** key again (do not hold), and the **MIN** icon will be displayed. Press the **HISTORY/-** key to view pressure (ABS or REL) min value.

Next, press the **SET** key for three seconds to clear the pressure, temperature and humidity minimum values. The minimum values will now display the current values.

Press the **SNOOZE/LIGHT** key to exit the min/max checking and cleaning mode, return to normal display mode.

7.8 Snooze Mode

If the alarm sounds, and you wish to silence the alarm, press the **SNOOZE/LIGHT** key, the backlight will turn on. The alarm icon will continue to flash and the alarm will silence for five minute. Press any key (**HISTORY/+**, **SET**, **ALARM**, **CHANNEL/+**) to permanently exit the **Snooze** mode.

7.9 Backlight Mode

IF the LED is off, press the **LIGHT** button once. The backlight will turn on for five seconds, and if no operation is performed for three seconds, the backlight will turn off.

Press and hold the **LIGHT** key for two seconds, and the backlight will turn on permanently, and

display **LED ON** icon will be displayed for three seconds in the time field.

IF the LED is on, press and hold the **LIGHT** button once, and the LED will turn off.

 **Note:** To dim the backlight display, press the **SNOOZE/LIGHT** button (on the top of the console) to toggle the backlight contrast level between 1 (the lowest setting) and the current setting (1-8).

 **Note:** To easily adjust the backlight when the backlight is on, press the **SNOOZE/LIGHT** button twice in quick succession to enter the **Backlight Contrast** Mode. **BRIGHT 8** will be displayed. Press **[+]** key or **[-]** key to adjust contrast value from 1 to 8, and press the **SET** key to exit.

 **Note:** If plugged into AC power, the time area will display **AC ON** and the backlight will remain on. It is not recommended leaving the backlight on for a long period of time when operating on batteries only, or the batteries will run down quickly.

7.10 Adjustment or Calibration

 **Note:** The calibrated value can only be adjusted on the console. The remote sensor(s) always displays the un-calibrated or measured value.

 **Note:** The measured humidity range is between 10 and 99%. Humidity cannot be accurately measured outside of this range. Thus, the humidity cannot be calibrated below 10% or above 99%.

The purpose of calibration is to fine tune or correct for any sensor error associated with the devices margin of error. The measurement can be adjusted from the console to calibrate to a known source.

Calibration is only useful if you have a known calibrated source you can compare it against, and is optional. This section discusses practices, procedures and sources for sensor calibration to reduce manufacturing and degradation errors. Do not compare your readings obtained from sources such as the internet, radio, television or newspapers. They are in a different location and typically update once per hour.

The purpose of your weather station is to measure conditions of your surroundings, which vary significantly from location to location.

The WS-12 supports up to eight remote sensors. Each of the eight sensors can be calibrated.

If you own more than one remote sensor, press the **CHANNEL/+** button first to display the specific channel you wish to calibrate.

7.10.1 Temperature Calibration

In normal mode, press and hold the **SET** and **CHANNEL/+** keys at the same time for five seconds to enter the temperature calibration mode. The indoor temperature will begin flashing.

Press the [+] or [-] key to increase or decrease the temperature reading (in increments of 0.1). Press and hold the [+] or [-] key for three seconds to increase or decrease rapidly.

Press the **ALARM** key to reset current value.

Press the **SET** key switch to next channel (1through 8). To exit the calibration mode at any time, press the **SNOOZE/LIGHT** button on the top of the display console. If no operation is performed, the calibration mode will timeout in 30 seconds.

7.10.2 Humidity Calibration

In normal mode, press and hold the **SET** and **HISTORY/-** keys at the same time for five seconds to enter the humidity calibration mode. The indoor humidity will begin flashing.

Press the [+] or [-] key to increase or decrease the humidity reading (in increments of 1%). Press and hold the [+] or [-] key for three seconds to increase or decrease rapidly.

Press the **ALARM** key to reset current value.

Press the **SET** key switch to next channel (1through 8). To exit the calibration mode at any time, press the **SNOOZE/LIGHT** button on the top of the display console. If no operation is performed, the calibration mode will timeout in 30 seconds.

 **Note:** Humidity is a difficult parameter to measure accurately and drifts over time. The calibration feature allows you to zero out this error. To calibrate humidity, you will need an accurate source, such as a sling psychrometer or Humidipaks One Step Calibration kit.

7.10.3 Wind Speed, Rainfall and Barometric Pressure Calibration

In normal mode, press and hold the **SET** and **ALARM** keys at the same time for five seconds to enter the wind speed, rainfall and pressure calibration mode. The wind speed will begin flashing.

Press the [+] or [-] key to increase or decrease the wind speed reading. Press and hold the [+] or [-] key for three seconds to increase or decrease rapidly.

Press the **ALARM** key to reset current value.

Press the **SET** key switch to rainfall, absolute pressure and relative pressure. To exit the calibration mode at any time, press the **SNOOZE/LIGHT** button on the top of the display console.

If no operation is performed, the calibration mode will timeout in 30 seconds.

1. Wind Speed (Gust) Calibration. After entering the Calibration Mode, the Wind Speed Calibration gain will begin flashing (the default is 1.0). Press the [+] or [-] button to adjust the wind speed calibration factor from 0.75 to 1.25, where:

$$\text{Calibrated Wind Speed} = \text{Calibration factor} \times \text{Measured Wind Speed}$$

 **Note:** The wind gust is also affected by the wind speed calibration factor.

 **Discussion:** Wind speed and wind gust are adversely affected by installation constraints. The rule of thumb is to install the weather station four times the distance of the height of the tallest obstruction (for example, a 6 m house would require an installation 24 m away).

In many instances, due to trees and other obstructions, this is not possible. The wind speed calibration allows you to correct for these obstructions.

In addition to installation challenges, wind speed bearings (any moving part) wears over time. To correct for wear, the correction value can be increased until the wind cups must be replaced.

Without a calibrated source, wind speed is a difficult parameter to measure. We recommend using a calibrated wind meter and constant, high speed fan.

2. Rainfall Calibration (1 Hour, 24 Hour, Daily, Monthly, Total). Press the SET key again and the Rain Calibration value will begin flashing (the default is 1.0). Press the [+] or [-] button to adjust the rain calibration factor from 0.75 to 1.25, where:

$$\text{Calibrated Rain} = \text{Calibration factor} \times \text{Measured Rain}$$

 **Discussion:** The rain collector is calibrated at the factory based on the funnel diameter. The bucket tips every 0.01” of rain (referred to as resolution). The accumulated rainfall can be compared to a sight glass rain gauge with an aperture of at least 4”.

 **Note:** that debris and insects can collect inside the tipping mechanism (they make a good spiders nest). Carefully remove the funnel and inspect the tipping mechanism for debris prior to calibration.

3. Absolute Pressure and Relative Pressure Calibration. Press the SET key again to enter the absolute pressure and relative pressure calibration mode. Press the [+] or [-] key to increase or decrease the pressure reading (in increments of 0.01inHg)

 **Note:** The display console displays two different pressures: absolute (measured) and relative (corrected to sea-level).

To compare pressure conditions from one location to another, meteorologists correct pressure to sea-level conditions. Because the air pressure decreases as you rise in altitude, the sea-level corrected pressure (the pressure your location would be at if located at sea-level) is generally higher than your measured pressure.

Thus, your absolute pressure may read 28.62 inHg (969 mb) at an altitude of 1000 feet (305 m), but the relative pressure is 30.00 inHg (1016 mb).

The standard sea-level pressure is 29.92 in Hg (1013.2hpa). This is the average sea-level pressure around the world. Relative pressure measurements greater than 29.92 inHg (1013.2hpa) are considered high pressure and relative pressure measurements less than 29.92 inHg are considered low pressure.

To determine the relative pressure for your location, locate an official reporting station near you (the internet is the best source for real time barometer conditions, such as Weather.com or Wunderground.com), and set your weather station to match the official reporting station.

8 Alarm Mode

The WS-12 includes the following alarms:

- Time
- Indoor Temperature
- Indoor Humidity
- Channel 1 Temperature
- Channel 1 Humidity
- Channel 1 Feels Like Temperature
- Channel 1 Dew Point
- Wind Speed
- Wind Gust
- Hourly Rainfall
- 24 Hour Rainfall
- Absolute Pressure
- Relative Pressure

Channels 2-8 alarms are not supported.

8.1 Alarm Operation

When an alarm condition is exceeded, the alarm icon will flash  (visual) and the alarm beeper will sound (audible). To silence the beeper, press any key. The alarm beeper can be permanently silenced by referencing Section 8.4.

8.2 Viewing the High and Low Alarms

To view the current alarm settings, press and hold the **ALARM** key for three seconds to enter the alarm mode. The HI alarms will be displayed along with the alarm clock time.

Press the **ALARM** key to view the LOW alarms along with the alarm clock time. Press the **SET** key to view rainfall (1h and 24h) high alarm and pressure (ABS and REL) high/low alarm.

Press the **SNOOZE/LIGHT** key at any time to return to the normal mode

8.3 Setting the Alarms

Press and hold the **ALARM** key for three seconds to enter the alarm mode.

Next, press and hold the **SET** key for three seconds. The first alarm parameter will begin flashing (alarm hour).

To save the alarm setting and proceed to the next alarm parameter, press (do not hold) the **SET** key.

To adjust the alarm parameter, press the [+] or [-] key to increase or decrease the alarm settings, or press and hold the [+] or [-] key for three seconds to increase or decrease the alarm settings rapidly.

Press the **ALARM** key to turn on (the alarm icon will appear ) and off the alarm.

Press the **SNOOZE/LIGHT** key twice at any time to return to the normal mode. After 30 seconds of inactivity, the alarm mode will time out and return to normal mode.

The following is a list of the individual alarm parameters that are set (in order):

1. Alarm hour
2. Alarm minute
3. Rainfall (1h) high alarm
4. Rainfall (24h) high alarm
5. Wind Gust high alarm
6. Wind speed high alarm
7. Outdoor (channel 1) temperature high alarm
8. Outdoor (channel 1) temperature low alarm
9. Outdoor(channel 1) humidity high alarm
10. Outdoor(channel 1) humidity low alarm
11. Outdoor (channel 1) feels like high alarm
12. Outdoor (channel 1) feels like low alarm
13. Outdoor (channel 1) dew point high alarm

-
14. Outdoor (channel 1) dew point low alarm
 15. Absolute pressure high alarm
 16. Absolute pressure low alarm
 17. Relative pressure high alarm
 18. Relative pressure low alarm
 19. Indoor temperature high alarm
 20. Indoor temperature low alarm
 21. Indoor humidity high alarm
 22. Indoor humidity low alarm

 **Note:** To prevent repetitive temperature alarming, there is a 0.9 °F tolerance band. For example, if you set the high alarm to 80.0 °F and silence the alarm, the alarm icon will continue to flash until the temperature falls below 79.1°F, at which point, the alarm will reset and must increase above 80.0 °F to activate again.

 **Note:** To prevent repetitive alarming of humidity, there is a 4% tolerance band. For example, if you set the high alarm to 60% and silence the alarm, the alarm icon will continue to flash until the humidity falls below 56%, at which point, the alarm will reset and must increase above 60% to activate again.

8.4 Alarm and Command Key Beeper ON/OFF Mode

The beeper can be silenced for both alarms and key strokes.

In normal mode, press and hold the **HISTORY/-** key for three seconds to toggle the beeper on or off (depending on the current setting).

The **BUZZON** (beeper on) or **BUZZOFF** (beeper off) icon will appear in the time area for three seconds. Press and hold the **HISTORY/-** key again for three seconds to toggle the **BUZZON** or **BUZZOFF** command.

9 Other Console Features

The following section describes additional features.

9.1 Feels Like Temperature

Feels like temperature is a combination of Heat Index and Wind Chill.

At temperatures less than 40°F, the wind chill is displayed, as shown in the National Weather Service Wind Chill Table below:

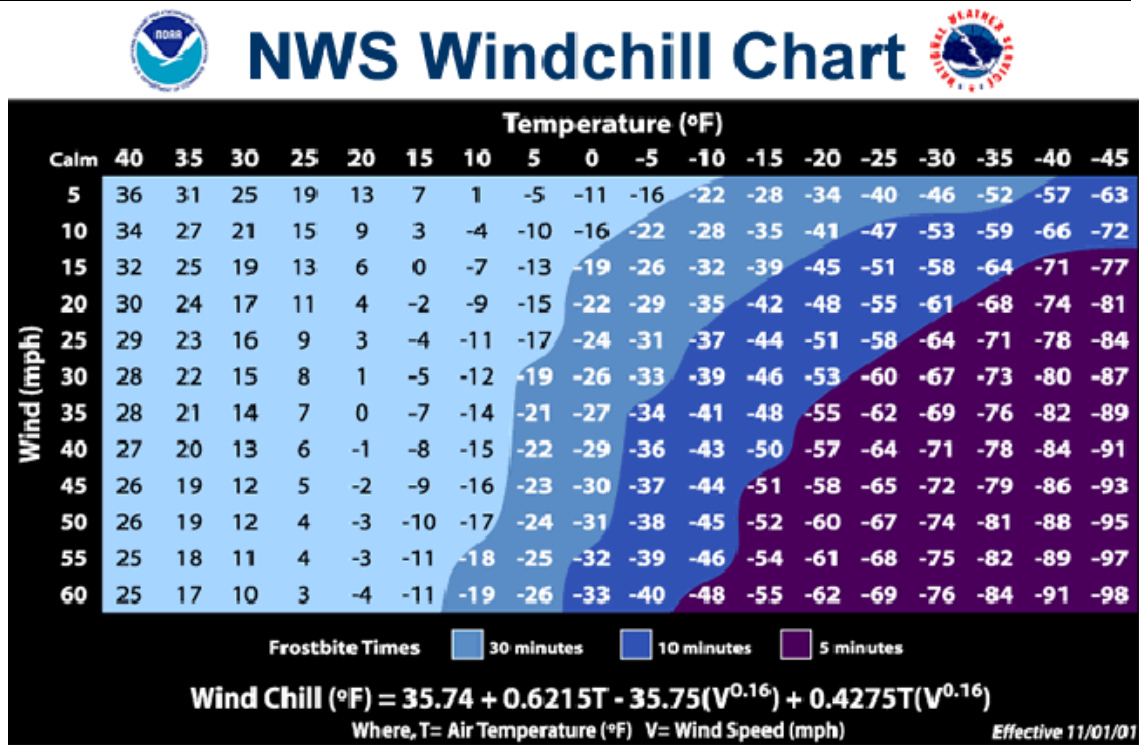

Figure 19

At temperatures greater than 80°F, the heat index is displayed, as shown in the National Weather Service Heat Index Table below:

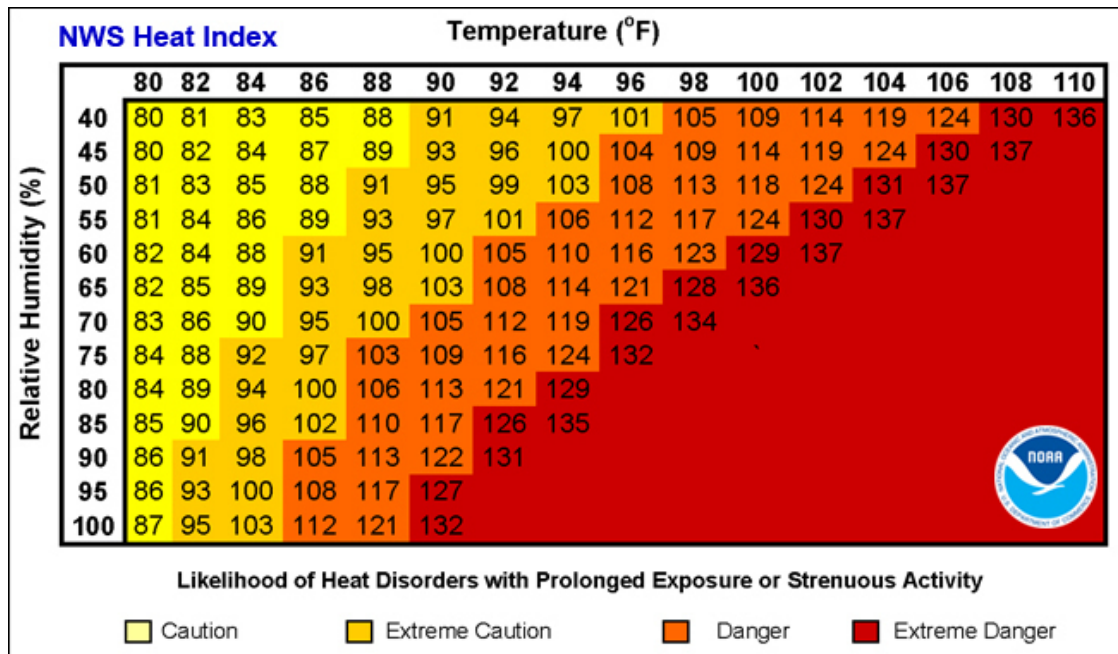

Figure 20

When the temperature is between 40°F and 80°F, the Channel 1 temperature is displayed (Feels Like temperature is the same as Channel 1 temperature).

9.2 Moon Phase

The following moon phases are displayed based on the calendar date.

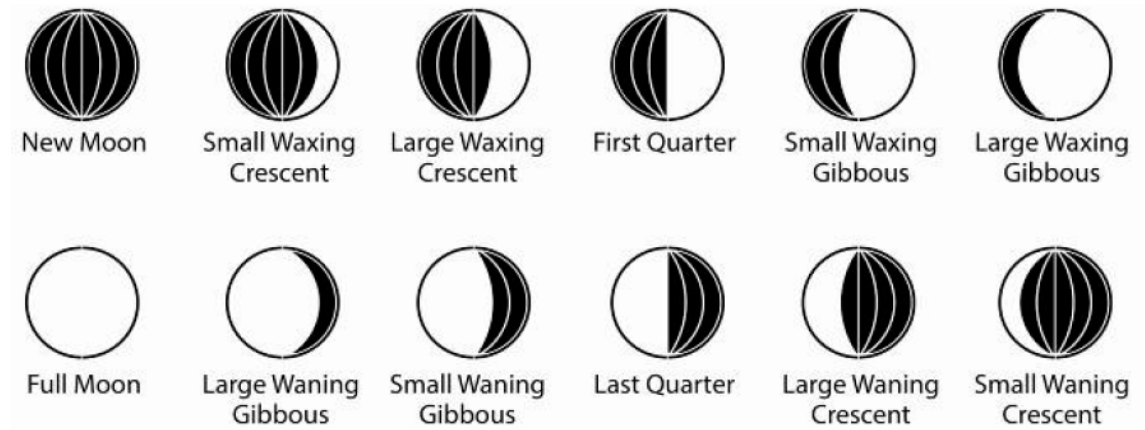

Figure 21

9.3 Personalizing Color Ranges

You can customize your background color ranges to suit your location, or personal preferences.

For example, if you live in Alaska, your definition of hot and cold may be very different if you live in Arizona.

Likewise, if you track your indoor comfort level, your comfort range may be very different than someone else.

Example 1: I live in Arizona, and the temperature ranges from 20 °F to 110 °F.

Color Increment = $(HI-LOW)/9 = (110 - 20)/9 = 10$ °F.

Example 2: I live in Alaska, and the temperature ranges from -20°F to 70°F.

Color Increments = $(HI-LOW)/11 = (70 - (-20))/9 = 10$ °F.

9.4 Low Battery Icon

A low battery indicator icon is shown in the display window for each sensor. When the low battery icon appears (the battery voltage is lower than 2.4V), replace the batteries in the sensor with fresh batteries. Be sure to never mix old and new batteries, and never mix battery types such as alkaline and lithium together.

10 Glossary of Terms

Term	Definition
Accuracy	Accuracy is defined as the ability of a measurement to match the actual value of the quantity being measured.
Hygrometer	A hygrometer is a device that measures relative humidity. Relative humidity is a term used to describe the amount or percentage of water vapor that exists in air.
Range	Range is defined as the amount or extent a value can be measured.
Resolution	Resolution is defined as the number of significant digits (decimal places) to which a value is being reliably measured.
Wind Vane	A wind vane is a device that measures the direction of the wind. The wind vane is usually combined with the anemometer. Wind direction is the direction from which the wind is blowing.
Absolute Barometric Pressure	Relative barometric pressure, corrected to sea-level. To compare pressure conditions from one location to another, meteorologists correct pressure to sea-level conditions. Because the air pressure decreases as you rise in altitude, the sea-level corrected pressure (the pressure your location would be at if located at sea-level) is generally higher than your measured pressure.
Relative Barometric Pressure	Measured barometric pressure relative to your location or ambient conditions.
HectoPascals (hPa)	Pressure units in SI (international system) units of measurement. Same as millibars (1 hPa = 1 mbar)
Inches of Mercury (inHg)	Pressure in Imperial units of measure. 1 inch of mercury = 33.86 millibars

11 Specifications

11.1 Wireless Specifications

- Line of sight wireless transmission (in open air): 300 feet, 100 feet under most conditions
- Frequency: 433.92 MHz
- Update Rate: 60 seconds for rain sensor and thermo-hygrometer sensor, 16 seconds for wind sensor.

11.2 Measurement Specifications

The following table provides specifications for the measured parameters.



Measurement	Range	Accuracy	Resolution
Indoor Temperature	32 to 140 °F	± 1 °F	0.1 °F
Outdoor Temperature	-40 to 140 °F	± 1 °F	0.1 °F
Indoor Humidity	10 to 99 %	± 5% (only guaranteed between 20 to 90%)	1 %
Outdoor Humidity	10 to 99%	± 5% (only guaranteed between 20 to 90%)	1 %
Rain	0 to 396in	<0.6in: ±0.04in, 0.6in to 396in: ±7%	<39.4in (0.012in) >39.4in (0.04in)
Wind Direction	0 - 360 °	45° (8 point compass)	45° (8 point compass)
Wind Speed	0 to 112mph	4.5 mph ~22.4mph: ± 6.7mph, 22.4mph ~112mph: ± 10% (whichever is greater)	0.1mph
Barometric Pressure:	8.85 to 32.50 inHg	± 0.08 inHg	0.01 inHg

11.3 Power Consumption

- Base station (display console) : 4 x AA 1.5V Alkaline or Lithium batteries (not included)
- Adaptor: 6V~ 500mA
- Thermo-hygro Sensor : 2 x AAA alkaline batteries or Lithium batteries (not included)
- Rain sensor: 4 x AAA alkaline batteries or Lithium batteries (not included)
- Wind sensor: 4 x AAA alkaline batteries or Lithium batteries (not included)
- Battery life: Minimum 12 months for base station with excellent reception. Intermittent reception and multiple sensors may reduce the battery life.

Minimum 12 months for sensors (use lithium batteries in cold weather climates less than -4 °F)

12 Troubleshooting Guide

Problem	Solution
Wireless remote (thermo-hygrometer) not reporting in to console. There are dashes (---) on the display console.	If any of the sensor communication is lost, dashes (---) will be displayed on the screen. To reacquire the signal, press and hold the CHANNEL/+ button for 3 seconds, and the remote search icon  will be constantly displayed. Once the signal is reacquired, the remote search icon  will turn off, and the current values

Problem	Solution
	<p>will be displayed.</p> <p>The maximum line of sight communication range is 300 feet and 100 feet under most conditions. Move the sensor assembly closer to the display console.</p> <p>If the sensor assembly is too close (less than 5'), move the sensor assembly away from the display console.</p> <p>Make sure the remote sensor LCD display is working and the transmitter light is flashing once per 60 seconds.</p> <p>Install a fresh set of batteries in the remote thermo-hygrometer. For cold weather environments, install lithium batteries.</p> <p>Make sure the remote sensors are not transmitting through solid metal (acts as an RF shield), or earth barrier (down a hill).</p> <p>Move the display console around electrical noise generating devices, such as computers, TVs and other wireless transmitters or receivers.</p> <p>Move the remote sensor to a higher location. Move the remote sensor to a closer location.</p>
<p>Temperature sensor reads too high in the day time.</p>	<p>Make sure the thermo-hygrometer is mounted in a shaded area. The pre preferred location is a north facing wall because it is in the shade most of the day.</p> <p>Consider the following radiation shield if this is not possible: http://www.ambientweather.com/amwesrpatean.html</p>
<p>Indoor and Outdoor Temperature do not agree</p>	<p>Allow up to one hour for the sensors to stabilize due to signal filtering. The indoor and outdoor temperature sensors should agree within 2 °F (the sensor accuracy is ± 1 °F).</p> <p>Use the calibration feature to match the indoor and outdoor temperature to a known source.</p>
<p>Indoor and Outdoor Humidity do not agree</p>	<p>Allow up to one hour for the sensors to stabilize due to signal filtering. The indoor and outdoor humidity sensors should agree within 10 % (the sensor accuracy is ± 5 %).</p>

Problem	Solution
	Use the calibration feature to match the indoor and outdoor humidity to a known source.
Display console contrast is weak	Replace console batteries with a fresh set of batteries.
Outdoor color does not change as expected.	Make sure the outdoor sensor is assigned to Channel 1.

13 Maintenance

- Clean the rain gauge once every 3 months. Pull out the Rain Gauge Filter drawer, as shown in Figure 15.
- Replace the wind, rain and thermo-hygrometer transmitter batteries once every 1-2 years
- Clean the anemometer solar panel once every 3 months.

14 Accessories

The following software and hardware accessories are available for this weather station at www.AmbientWeather.com.

Accessory	Description
Energizer AAA Lithium Battery (2-pack) - Batteries for Long Life and Cold Climates	AAA lithium batteries for cold weather climates.
Energizer AA Lithium Battery (2-pack) - Batteries for Long Life and Cold Climates	AA lithium batteries for cold weather climates.
Ambient Weather SRS100LX Temperature and Humidity Solar Radiation Shield	Solar Radiation Shield improves temperature accuracy for hot weather climates. Install over thermo-hygrometer.
Ambient Weather Humidity Calibration Kits	One step calibration kits for digital hygrometers use salt slurry formula to accurately calibrate the indoor and outdoor hygrometers.

15 Liability Disclaimer

Please help in the preservation of the environment and return used batteries to an authorized depot. The electrical and electronic wastes contain hazardous substances. Disposal of electronic waste in wild country and/or in unauthorized grounds strongly damages the environment.

Reading the “User manual” is highly recommended. The manufacturer and supplier cannot accept any responsibility for any incorrect readings and any consequences that occur should an inaccurate reading take place.

This product is designed for use in the home only as indication of weather conditions. This product is not to be used for medical purposes or for public information.

The specifications of this product may change without prior notice.

This product is not a toy. Keep out of the reach of children.

No part of this manual may be reproduced without written authorization of the manufacturer.

Ambient, LLC WILL NOT ASSUME LIABILITY FOR INCIDENTAL, CONSEQUENTIAL, PUNITIVE, OR OTHER SIMILAR DAMAGES ASSOCIATED WITH THE OPERATION OR MALFUNCTION OF THIS PRODUCT.

16 FCC Statement

Statement according to FCC part 15.19:

This device complies with part 15 of the FCC rules. Operation is subject to the following two conditions:

1. This device may not cause harmful interference.
2. This device must accept any interference received, including interference that may cause undesired operation.

Statement according to FCC part 15.21:

Modifications not expressly approved by this company could void the user's authority to operate the equipment.

Statement according to FCC part 15.105:

NOTE: This equipment has been tested and found to comply with the limits for a Class B digital device, pursuant to Part 15 of the FCC Rules. These limits are designed to provide reasonable protection against harmful interference in a residential installation. This equipment generates, uses and can radiate radio frequency energy and, if not installed and used in accordance with the instructions, may cause harmful interference to radio communications.

However, there is no guarantee that interference will not occur in a particular installation. If this equipment does cause harmful interference to radio or television reception, which can be determined by turning the equipment off and on, the user is encouraged to try to correct the interference by one or more of the following measures:

- Reorient or relocate the receiving antenna.
- Increase the separation between the equipment and receiver.
- Connect the equipment into an outlet on a circuit different from that to which the receiver is connected.
- Consult the dealer or an experienced radio/TV technician for help.

17 Warranty Information

Ambient, LLC provides a 1-year limited warranty on this product against manufacturing defects in materials and workmanship.

This limited warranty begins on the original date of purchase, is valid only on products purchased and only to the original purchaser of this product. To receive warranty service, the purchaser must contact Ambient, LLC for problem determination and service procedures.

Warranty service can only be performed by a Ambient, LLC. The original dated bill of sale must be presented upon request as proof of purchase to Ambient, LLC.

Your Ambient, LLC warranty covers all defects in material and workmanship with the following specified exceptions: (1) damage caused by accident, unreasonable use or neglect (lack of reasonable and necessary maintenance); (2) damage resulting from failure to follow instructions contained in your owner's manual; (3) damage resulting from the performance of repairs or alterations by someone other than an authorized Ambient, LLC authorized service center; (4) units used for other than home use (5) applications and uses that this product was not intended (6) the products inability to receive a signal due to any source of interference or metal obstructions and (7) extreme acts of nature, such as lightning strikes or floods.

This warranty covers only actual defects within the product itself, and does not cover the cost of installation or removal from a fixed installation, normal set-up or adjustments, claims based on misrepresentation by the seller or performance variations resulting from installation-related circumstances.

