

Walkie Talkie

Model: ATR-22

THANK YOU!

We are grateful for your choice of our transceiver. We believe that this easy-to-use transceiver will provide dependable and cost-effective communications for you.

Our professional two-way radios incorporate the latest in advanced technology and craft. So you will be pleased with the quality and features of our products. Please read this manual carefully to ensure you know how to properly operate the radio before use.

PRECAUTIONS

1. Refer service to qualified technicians only.
2. Do not disassemble or modify the transceiver for any reason.
3. Do not expose the transceiver under direct sunlight long time or to extremely hot condition.
4. Do not place the transceiver on the unstable surface.
5. Keep the transceiver out of dust, moisture, and water.
6. Do not operate the transceiver or charge the battery pack under explosive conditions.

SAFETY:

It is important that the operator is aware of and understands hazards common to the operation of any transceiver.

WARNING

Please Turn the Transceiver Power off in the Following Locations:

- * In explosive atmospheres (flammable gas, dust particles, metallic powders, grain powders, etc.).
- * While taking on fuel or while parking at gasoline services stations.
- * Near explosives or blasting sites.
- * In medical institutions or aircrafts.

UNPACKING AND CHECKING EQUIPMENTS

Carefully unpack the transceiver. We recommend that you identify the items listed in the following table before discarding the packing material.

If any items are missing or have been damaged during shipment, please contact the dealers immediately.

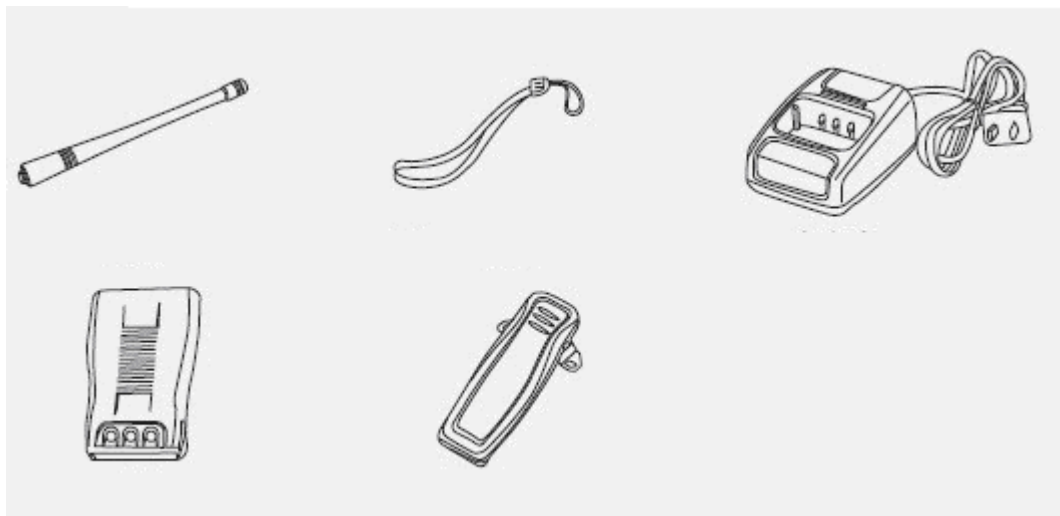

SUPPLIED ACCESSORIES

Item Name	Quantity
-----------	----------

Antenna	
---------	--

Handstrap	
-----------	--

Charger	
---------	--

Battery	
---------	--

Belt Clip	
-----------	--

User's Manual	
---------------	--

CHARGING THE LI-ION BATTERY PACK

Please charge the new battery pack before using it.

The new or stored (more than two months) battery pack, which can not reach its full capacity for the first charging. After 2 or 3 times charging and discharging, it can reach full charge.

Just see the following instructions:

1. Plug the adapter into an electric socket.
2. Insert the transceiver or battery into the drop-in charging tray.
3. Ensure that the battery's contacts connect with the drop-in charging tray properly, while the charging is taking place, the light will glow red.
4. After 3 hours charging, the LED indicator will light green which means the full charge. Now remove the battery or the transceiver from the drop-in charging tray.

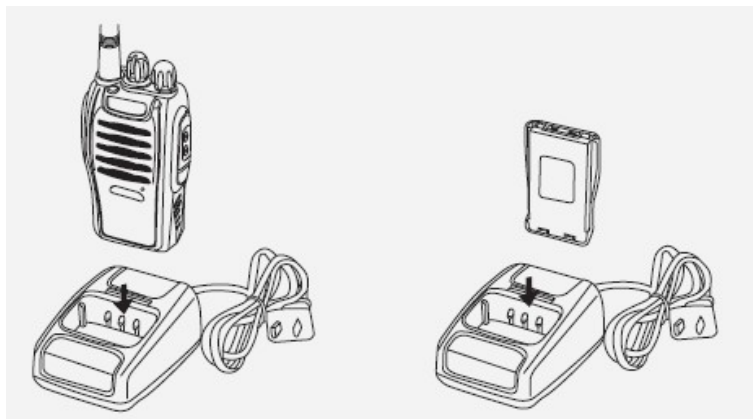

NOTE: Do not recharge the battery pack if it is fully charged. Doing so may cause the life of the battery pack to shorten or the battery pack may be damaged.

INSTALLING/REMOVING THE BATTERY PACK

The usage time of JL-11 Battery Pack is about 8 hours, which is based upon 5% transmit/5% receive/90% standby (standard duty cycle). See following images:

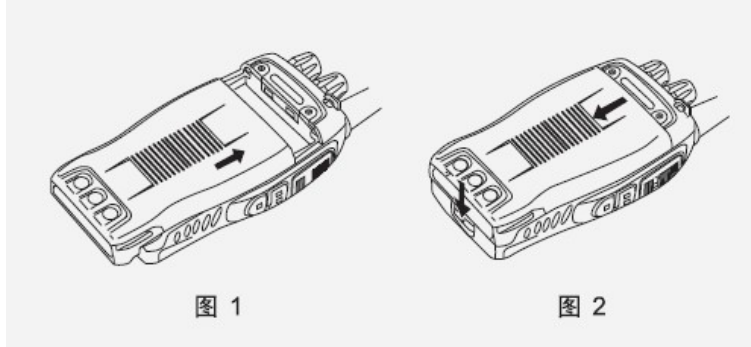

CAUTION:

1. Do not short-circuit the terminals of the battery or throw the battery into the fire.
2. Do not disassemble the battery pack yourself.

INSTALLING THE ANTENNA

Screw the antenna into the connector on the top of the transceiver by holding the antenna at its base and turning it clockwise until secure.



NOTE:

The antenna is neither a handle, a key ring retainer, nor a speaker, microphone attachment point. Using the antenna in these ways may damage the antenna and degrade your transceiver's performance.

INSTALLING THE BELT CLIP

If necessary, install the belt clip into the location on the back of the battery. (See Figure)

NOTE:

If the belt clip is not installed, its mounting location may get hot during continuous transmission or under heated environment.

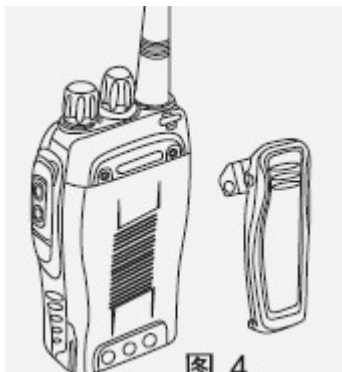

INSTALLING THE (OPTIONAL) SPEAKER/MICROPHONE

Insert the speaker/microphone plugs into the speaker/microphone jacks of the transceiver.

NOTE: The transceiver is not fully water resistant when using speaker/microphone.

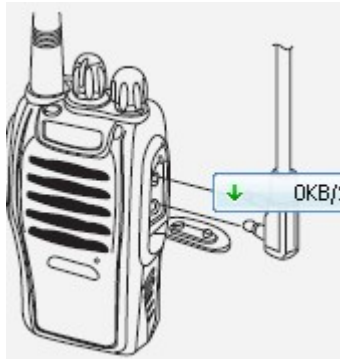

GETTING ACQUAINTED

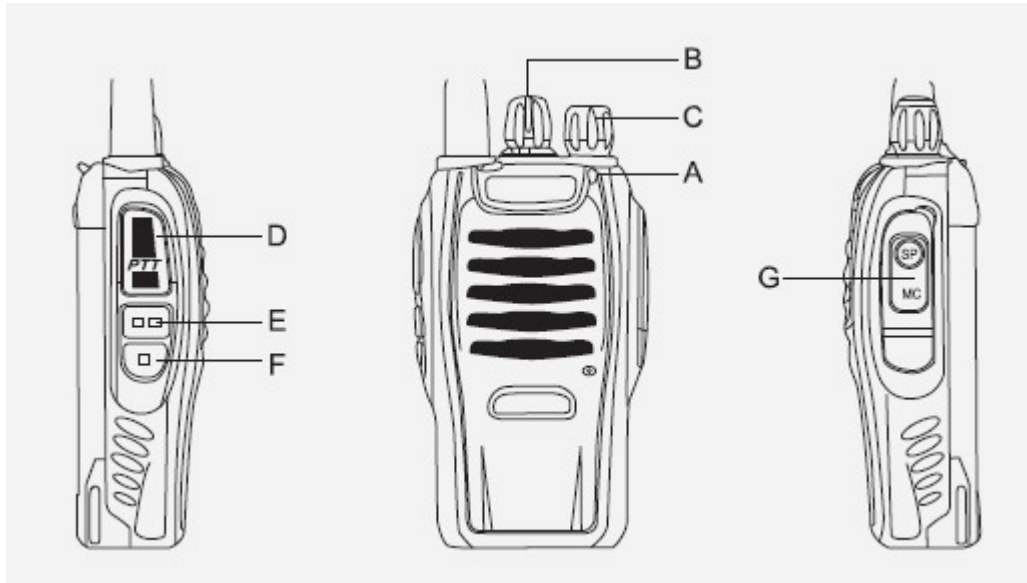

A. Led Indicator-- The LED indicator lights continuously red when transmitting. And lights green when in reception condition.

B. Channel Switch—Rotate it to select the channel. No.16 channel is scanning channel.

C. POWER SWITCH/VOLUME CONTROL

Turn clockwise to switch ON the transceiver.

Turn counterclockwise fully to switch OFF the transceiver. Rotate to adjust the volume.

D. PTT (PUSH-TO-TALK) BUTTON

Press this button, then speak into the microphone to call a station.

Release to receive a call.

E. MONITOR BUTTON

Press and hold (Squelch OFF) to hear the background noise; Release to return to normal operation.

F. FUNCTION KEY—Just press to activate the torch function.

G. SPEAKER/MICROPHONE JACKS

OPERATION

SWITCHING POWER ON/OFF

Turn the power switch/volume control clockwise. You will hear a beep and speech, indicating the transceiver is ON.

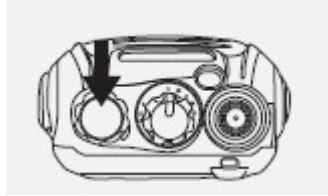

ADJUSTING THE VOLUME

Hold Monitor button down to listen to audio level while rotating the Power switch/Volume control. Rotate clockwise to increase and counterclockwise to decrease volume.



SELECTING THE CHANNEL

Turn the channel switch to select your desired channel. NO.16 is Scanning Channel.

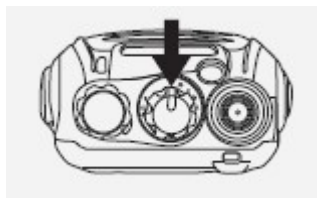

TRANSMITTING

1.To transmit, press and hold [PTT] and speak into the microphone in your normal tone of voice.

The LED indicator lights continuously red when transmitting.

To maximize sound clarity at the receiving station, hold the transceiver 2 to 3 inches from mouth and talk in normal tone of voice.

2.Release [PTT] to receive.

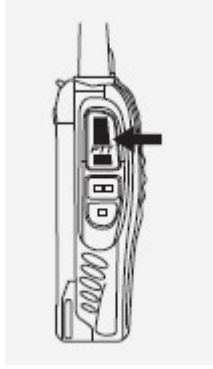

ADDITIONAL FUNCTIONS:

SQUELCH LEVEL

The purpose of Squelch is to mute the speaker when no signals are present (Squelch OFF). With the squelch level correctly set, you will hear sound only while actually receiving signals (Squelch ON). The squelch level can be adjusted via program software.

TIME-OUT TIMER (TOT)

The purpose of the Time-out Timer is to prevent any caller from using a channel for an extended period of time which will cause thermal damage. The built-in Time-out Timer limits each transmission time to a certain time. The transmission time extends the certain time you set, an alert tone will sound.

SCAN

Scan is a useful function for hands-off monitoring of your favorite frequencies. When transceiver is set as SCAN via software, turn the channel selector to channel 16, the transceiver will automatically detect the activities of scanning channel from 1 to 15 (Different channel can be set) .

- 1.The transceiver stops scanning at the frequency (or memory channel) where a signal is detected. It then continues or stops scanning.
- 2.If there are less than 2 channels, it can not scan.
- 3.On channel 16, press PTT and MONI key, it will turn on the SCAN, or turn off the SCAN.
- 4.If the FM radio function is activated, it can not scan.

VOICE PROMPT

- 1.Voice Prompt ON/OFF can be set via software.
2. On channel 10, press PTT and MONI key, then switch on the transceiver, Voice Prompt can be cancelled or activated.
- 3.On channel 15, press PTT and MONI key, then switch on the transceiver to choose different voice prompt languages.

VOX(Voice Operated Transmission)

VOX eliminates the necessity of manually switching to the transmission Mode each time you want to transmit. The transceiver automatically switches to Transmission Mode when the VOX circuitry senses that you

have begun speaking into the microphone.

When you operate the VOX function, you must use an optional headset with microphone.

1. When operating the VOX function, be sure to set the VOX Gain level which allows the transceiver to recognize the sound levels.

2. If the microphone is too sensitive, the transceiver will begin transmitting when there is noise in the background.

3. If it is not sensitive enough, it will not pick up your voice when you begin speaking. Be sure to adjust the VOX Gain level to an appropriate sensitivity to allow smooth transmission.

On channel 1-5, press and hold the MONI and PTT, then switch on the transceiver, thus to activate the VOX functions ON/OFF.

EMERGENCY ALARM

On channel 11, press and hold the PTT and MONI, then switch the transceiver on, thus to activate the emergency alarm function ON/OFF.

Also it can be set with program software. If the function is OFF, the other transceiver receives the signal, it is not able to alarm.

Battery Saver

The battery saver function will decrease the amount of power used when a signal is not being received and no operations are being performed (no keys are being pressed, and no switches are being turned).

While the channel is not busy and no operation is performed for more than 10 seconds, Battery Saver turns ON.

When a signal is received or an operation is performed, Battery Saver turns OFF.

BATTERY LOW ALERT

Battery Low Alert reminds you of recharging.

When the battery power is very low, an alert tone will sound and the LED indicator will blink red. Please recharge or replace the battery pack.

MONITOR

When you are receiving and no signals present, the squelch function can mute the speaker, so you can not hear the background noise. If you want to switch the squelch function OFF, press and hold [MONI] button. It is very helpful when you want to adjust the volume level and receive the weak signals.

BUSY CHANNEL LOCK-OUT (BCL)

Busy Channel Lock-out function can be turned ON/OFF with program software on every channel.

When activated, BCL prevents you from interfering with other parties who may be using the same channel that you selected. Pressing the **PTT** switch while the channel is in use will cause your transceiver to emit an alert tone and transmission will be inhibited (you cannot transmit). Release the **PTT** switch to stop the tone and return to receive mode.

CTCSS/DCS

CTCSS (Continuous Tone Coded Squelch System)/ (Digital Coded Squelch)

You may sometimes want to hear calls from only specific persons or groups. In this case, use the selective call which allows you to ignore unwanted calls from other persons who are using the same frequency.

CTCSS or DCS is a sub-audible tone and is selectable from among the 39 or 83 tone frequency listed.

Note

CTCSS and DCS do not cause your conversation to be private and scrambled. It only relieves you from listening to unwanted conversations.

SPECIFICATIONS:

Frequency Range:406.1-470MHz

RF Rated Power: $\leq 5W$

Channel Spacing: 12.5kHz and 6.25kHz

Channel Capacity:16s

Operated Voltage: 3.7V

Dimensions:115mm×60mm×33mm

Weight: 180g

NOTE

All specifications are subject to change without notice.

TROUBLESHOOTING GUIDE

No Power

·Check battery installation and/or replace batteries.

Voltage Capacity Quickly Go Out.

The battery life is over, replace new one.

Couldn't I communicate with other group members.

First, please verify that the channel frequency and the CTCSS you are using are the same as those of your group members. If the channel frequency and the CTCSS are the same, please verify that your group members are within the radio coverage

Hear the voice from other groups.

Please change your CTCSS for the channel. At the same time, you also need to the CTCSS for all the radios in your group. If you don't like this, you may apply another channel frequency.

Why can I hear the voices clearly from other group, sometimes, my voice is intermittent.

Please check whether the MIC is blocked by something. If so, Please return the radio to your authorized dealer for maintenance. Sometimes, your frequency is same as the frequency of other groups.

Can't turn on the radio and even it is turned on, it often shuts off automatically.

Please check the battery contacts on the radio. If it is broken or twisted, please return the radio to your authorized dealer for maintenance

WARRANTY CARD

Model:

Serial NO.:

Dealer:

User name:

Address:

Purchase Date:

Tel. NO.:

Fax NO.:

Zip Code:

Warranty Remarks:

1. The consumer keeps the warranty card as the proof for repairing.
2. The card is of validity with the stamp and date.
3. The card mustn't be altered. Please confirm that the card NO. and the machine NO. must be same, or else it is not valid.
4. The accessories, such as charger, battery, earphone, antenna, and program cable are not covered. Amcrest will repair or replace any defective parts during one year limited warranty period.
5. The consumer can send the machine to the purchase site or our maintenance sites for repairing.

SAFETY TRAINING INFORMATION



Your Amcrest radio generates RF electromagnetic energy during transmit mode. This radio is designed for and classified as “Occupational Use Only”, meaning it must be used only during the course of employment by individuals aware of the hazards, Warning and the ways to minimize such hazards. This radio is not intended for use by the “General Population” in an uncontrolled environment.

This radio has been tested and complies with the FCC RF exposure limits for “Occupational Use Only.” In addition, your Quansheng radio complies with the following Standards and Guidelines with regard to RF energy and electromagnetic energy levels and evaluation of such levels for exposure to humans:

KDB 865664 D01 SAR Measurement 100 MHz to 6 GHz v01r04, Evaluating Compliance with FCC Guidelines for Human Exposure to Radio Frequency Electromagnetic Fields.

- American National Standards Institute (C95.1–1992), IEEE Standard for Safety Levels with Respect to Human Exposure to Radio Frequency Electromagnetic Fields, 3 kHz to 300 GHz.

- American National Standards Institute (C95.3–1992), IEEE Recommended Practice for the Measurement of Potential y Hazardous Electromagnetic Fields— RF and Microwave.

To ensure that your exposure to RF electromagnetic energy is within the FCC allowable limits for occupational use, always adhere to the following

CAUTION guidelines:



- **DO NOT** operate the radio without a proper antenna attached, as this may damage the radio and may also cause you to exceed FCC

RF exposure limits. A proper antenna is the antenna supplied with

this radio by the manufacturer or an antenna specifically authorized by the manufacturer for use with this radio.

- **DO NOT** transmit for more than 50% of total radio use time (“50% duty cycle”). Transmitting more than 50% of the time can cause FCC RF exposure compliance requirements to be exceeded. The radio is transmitting when the “TX indicator” lights red. You can cause the radio to transmit by pressing the “PTT” switch.

- **ALWAYS** use BAOFENG authorized accessories (antennas, batteries, belt clips, speaker/mics, etc). Use of unauthorized accessories can cause the FCC RF exposure compliance requirements to be exceeded. Body-worn operations are restricted to belt-clips, holsters or similar accessories that have no metallic component in the assembly and that provide at least 1.5 cm separation between the device, including its antenna, and the user's body. To provide the recipients of your transmission the best sound quality, hold the antenna at least 5 cm (2 inches) from mouth, and slightly off to one side. The information listed above provides the user with the information needed to make him or her aware of RF exposure, and what to do to assure that this radio operates within the FCC RF exposure limits of this radio.

Electromagnetic Interference/Compatibility

During transmissions, your Amcrest radio generates RF energy that can possibly cause interference with other devices or systems. To avoid such interference, turn off the radio in areas where signs are posted to do so. **DO NOT** operate the transmitter in areas that are sensitive to electromagnetic radiation such as hospitals, aircraft, and blasting sites.

This device complies with Part 90 of the FCC rules. Operation is subject to the following two conditions: (1) This device may not cause harmful interference, and (2) this device must accept any interference received, including interference that may cause undesired operation.

Changes or modifications not expressly approved by the party responsible for compliance could void the user's authority to operate the equipment.