

**HD-SDI TX**  
**WIRELESS MODULE –**  
**FALCON TX**  
**AMN35254**  
**USER GUIDE 1.0**



---

# Important Notice

---

AMIMON Ltd. reserves the right to make corrections, modifications, enhancements, improvements, and other changes to its products and services at any time and to discontinue any product or service without notice. Customers should obtain the latest relevant information before placing orders and should verify that such information is current and complete. All products are sold subject to AMIMON's terms and conditions of sale supplied at the time of order acknowledgment.

AMIMON warrants performance of its hardware products to the specifications applicable at the time of sale in accordance with AMIMON's standard warranty. Testing and other quality control techniques are used to the extent AMIMON deems necessary to support this warranty. Except where mandated by government requirements, testing of all parameters of each product is not necessarily performed.

AMIMON assumes no liability for applications assistance or customer product design. Customers are responsible for their products and applications using AMIMON components. To minimize the risks associated with customer products and applications, customers should provide adequate design and operating safeguards.

AMIMON does not warrant or represent that any license, either express or implied, is granted under any AMIMON patent right, copyright, mask work right, or other AMIMON intellectual property right relating to any combination, machine, or process in which AMIMON products or services are used. Information published by AMIMON regarding third-party products or services does not constitute a license from AMIMON to use such products or services or a warranty or endorsement thereof. Use of such information may require a license from a third party under the patents or other intellectual property of the third party, or a license from AMIMON under the patents or other intellectual property of AMIMON.

Reproduction of information in AMIMON data books or data sheets is permissible only if reproduction is without alteration and is accompanied by all associated warranties, conditions, limitations, and notices. Reproduction of this information with alteration is an unfair and deceptive business practice. AMIMON is not responsible or liable for such altered documentation.

Resale of AMIMON products or services with statements different from or beyond the parameters stated by AMIMON for that product or service voids all express and any implied warranties for the associated AMIMON product or service and is an unfair and deceptive business practice. AMIMON is not responsible or liable for any such statements.

All company and brand products and service names are trademarks or registered trademarks of their respective holders.

## Contact Us

### US Office

2350 Mission College Blvd.  
Suite 500  
Santa Clara, CA 95054  
Tel: +1 650 641 7178

### Israeli Headquarters

2 Maskit St.  
Building D, 2nd Floor  
P.O.Box 12618  
Herzlia 46733, Israel  
Tel: +972-9-962-9222  
Fax: +972-9-956-5467  
contact@amimon.com

### Japan Office

FS Building 9F.  
1-14-9 Higashi-Gotanda Shinagawa-ku  
Tokyo 141-0022,  
Japan  
TEL +81-3-3444-4305  
contact.japan@amimon.com

---

# Revision History

---

Version	Date	Description
1.0	17 Feb 2013	Initial Release

Preliminary

# Table of Contents

<b>Important Notice .....</b>	<b>2</b>
<b>Revision History .....</b>	<b>3</b>
<b>Table of Contents .....</b>	<b>4</b>
<b>List of Figures.....</b>	<b>6</b>
<b>List of Tables .....</b>	<b>6</b>
<b>Chapter 1 7</b>	
<b>Introduction .....</b>	<b>7</b>
<b>Chapter 2 8</b>	
<b>Overview 8</b>	
<b>2.1 AMN35254 WHDI Source (TX): .....</b>	<b>8</b>
2.1.1 AMN35254 - General Guidelines (Tx).....	9
2.1.2 LEDs .....	11
2.1.3 On/Off switch.....	11
2.1.4 External On/Off switch connector .....	11
2.1.5 Boot button .....	11
2.1.6 Reset button.....	11
2.1.7 Input Voltage connector .....	11
2.1.8 Knob - Frequency selection commands .....	12
2.1.9 IR blaster.....	13
2.1.10 Audio AUX.....	13
2.1.11 USB.....	13
2.1.12 External On/Off switch connector .....	14
2.1.13 I2C connector.....	14
<b>2.2 Antennas .....</b>	<b>14</b>
<b>2.3 Block diagram of the TX AMN35254 .....</b>	<b>14</b>

**Chapter 3 16**

**FCC Caution ..... 16**

Preliminary

---

# List of Figures

---

Figure 1 - Tx AMN35254.....9  
Figure 2: TX - AMN35254 BLOCK DIAGRAM .....15

---

# List of Tables

---

Table 1: *Technical Specifications* .....7  
Table 2: *Transmitter Specifications* .....7  
Table 3 - Frequency selection commands.....12

Preliminary

## Introduction

The **AMN35254 / AMN36254** are respectively wireless A/V transmitter /receiver boards, which works at the 5GHz unlicensed band.

They are based on AMIMON's WHDI Professional chipset that consist of the AMN2220\_A4W / AMN2120\_A4W baseband receiver/transmitter and the MAXIM 2851/2850 ICs, presents the ultimate solution for HD-SDI system into a wireless one. The perfect HD/SD video, audio quality, the high robustness and the invisible latency of the wireless system are unmatched by any other wireless technology and presents a true alternative to cable. The WHDI system transmits **uncompressed** video and audio streams wirelessly and thus simplifies and eliminates system issues, such as: lip-sync, large buffers and other burdens like retransmissions or error propagation.

### System Technical Specifications:

<b>Video Resolution:</b>	1080p/50, 1080p/60, 1080/59.94i, 1080/50i, 1080/29.97p, 1080/23.98p, , 720/59.94p, 720/50p, 525i/59.94, 625i/50, 1080/24p, 1080/24PsF, 1080/23.98PsF,1080/25PsF
<b>Frequencies:</b>	Non-DFS Frequencies: 5.15 ~ 5.25 GHz 5.725~5.825 GHz DFS Frequencies: 5.25 ~ 5.35 GHz 5.47 ~ 5.725 GHz
<b>Video Interface:</b>	SDI with automatic detection (SD,HD and 3G) over 75 Ohm BNC.
<b>Environment:</b>	Operational - 0:40° C, 10%~90% humidity Storage - 0:55° C, 10%~90% humidity
<b>Range:</b>	Up to 50m line of sight.
<b>Audio:</b>	Over SDI

Table 1: *Technical Specifications*

### Transmitter Specifications:

Transmitter AMN35254	
<b>Video Interface:</b>	SDI pass through (Option to connect external connector board)
<b>Frequency Control:</b>	Analog knob with 4 manual fix (non DFS) frequencies and one for automatic frequency selection mode (included DFS).
<b>Antenna:</b>	3 transmitting+ 1 transmitting /Receiving
<b>Voltage:</b>	7-17 V
<b>Size:</b>	(L)130mm x (W)106mm x (H) 16mm
<b>User Control:</b>	3 LEDs indicating Power, Video lock and Network lock USB connector for software update Hidden button for registration Reset button

Table 2: *Transmitter Specifications*

---

## Chapter 2

# Overview

---

### 2.1 AMN35254 WHDI Source (TX):

The **AMN35254** WHDI Source is designed to modulate and transmit downstream video and audio content over the wireless medium and receive a control channel over the wireless upstream. The modulation uses a 40 MHz bandwidth and is carried over the 5GHz unlicensed band. Fig 2 shows a block diagram of the **AMN35254**. The HD-SDI input is connected to the Gennum SDI 2971A which converts the SDI signal to A/V digital bus that is connected to the AMN2120 baseband transmitter. It has a MIMO design of four wireless output channels and one input channel. The internal microcontroller (STM32103) is responsible for control and management.

The ST STM32F103 application microcontroller controls the SDI chip and the baseband AMN2120 chip using SPI standard bus. The application microcontroller provides USB device interface through a mini USB connector.



### 2.1.1 AMN35254 - General Guidelines (Tx)

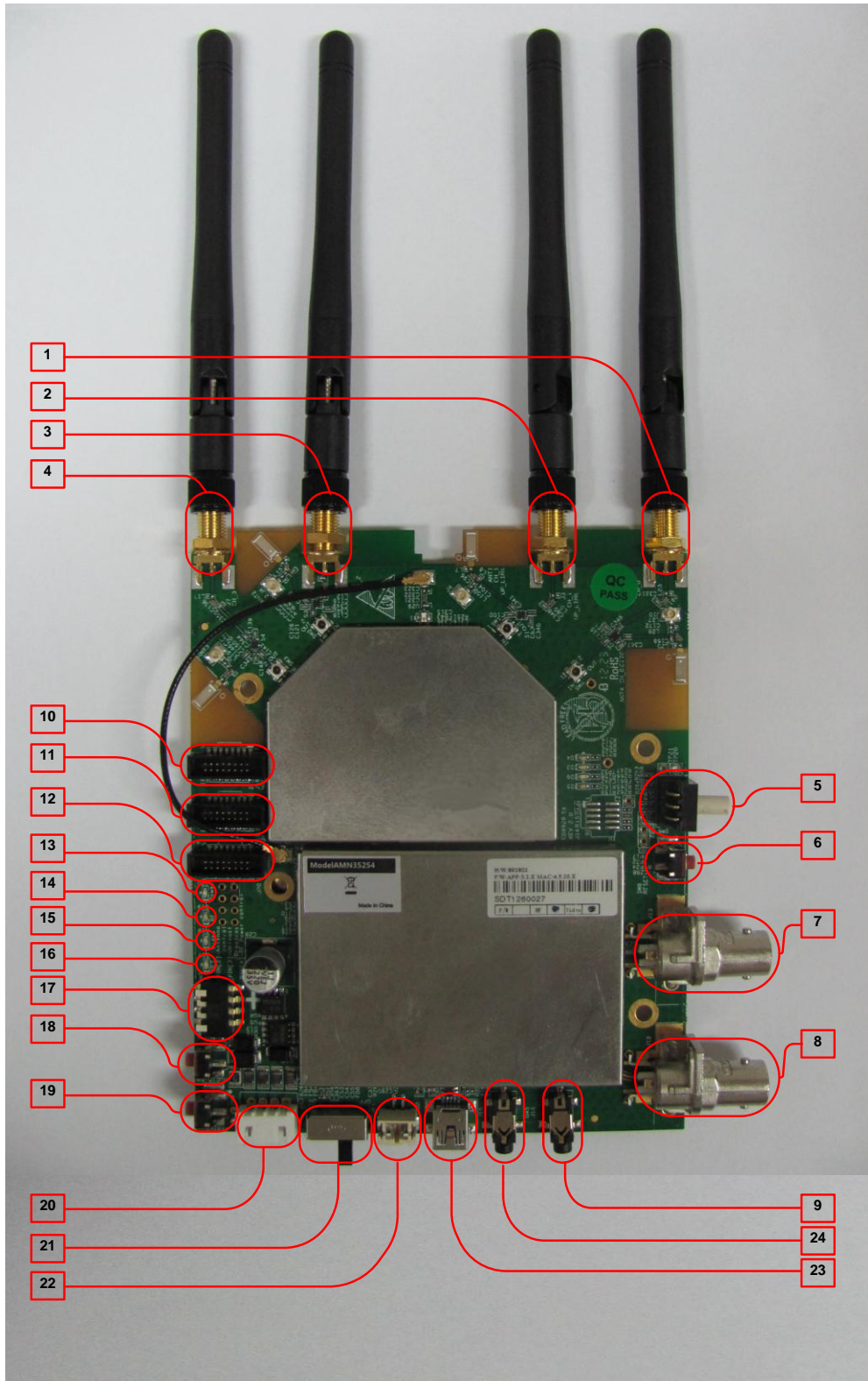

Figure 1 - Tx

AMN35254



Description of all connectors and their functionality including USB, Pass through, power conn pin out debug connectors,

### 2.1.1.1

01- Down link antenna CH#0	16- LED #1
02- Down link /UP link antenna CH#1	17- DIP Switch
03- Down link antenna CH#2	18- TBD
04- Down link antenna CH#3	19- Boot button & Registration
05- KNOB Switch	20- Input Voltage connector 7-17v
06- Reset Button	21- ON/OFF Switch
07- HD-SDI Output	22- External On/Off switch connector
08- HD-SDI Input	23- USB connector
09- External Audio	24- IR output connector
10- MAC DEBUG Port	
11- APP DEBUG Port	
12- Interface connector	
13- LED #4	
14- LED #3	
15- LED #2	

### 2.1.1.2 Knob Switch Frequency selection

- 0- Auto
- 1- 5190 MHz
- 2- 5230 MHz
- 3- 5755 MHz
- 4- 5795 MHz
- 5- 5755 MHz
- 6- 5795 MHz
- 7- Auto
- 8- Auto
- 9- Auto



## 2.1.2 LEDs

- 1- D20 - Power - on/off
- 2- D19 - Video Lock (SDI locked) - on/off
- 3- D18 - Network (link to Rx) - on/off
- 4- D17 - (TBD)

## 2.1.3 On/Off switch

System has a main switch that turns on and off.

The system is active when the switch is near J1(voltage input connector)

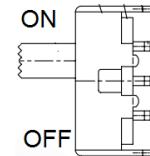

## 2.1.4 External On/Off switch connector

This connector is used for external On/Off switch. Pin 1 is VDD, Pin 2 is Power Enable.

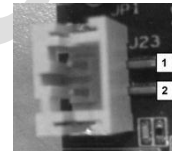

## 2.1.5 Boot button

Boot mode is a technical mode. In order to operate this mode you should hold "Boot button" for 5 seconds, when the system wakes up (press on the "Boot button" and then press on the "Reset button").

## 2.1.6 Reset button

The "Reset button" clears the dynamic memory and reboots the system.

## 2.1.7 Input Voltage connector

Input voltage connector contains 4 pins,

- 1- +BAT.
- 2- Power supply.
- 3- GND.
- 4- GND.

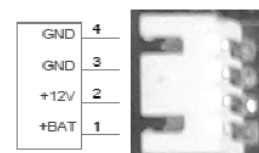

### 2.1.8 Knob - Frequency selection commands

The user will be able to select between fixed, non-DFS, frequencies, and automatic mode that will include all frequencies as specified in the table below. Using knob the user will determine on which fixed frequency system will work 1-4, or alternatively system in automatic mode – 5-9, system will hop between different available frequencies. (DFS channels cannot be used as fixed frequencies since system must hop automatically if radar is detected).

Table 3 - Frequency selection commands

40MHz Bandwidth Frequency [MHz]	US	Europe
	SW Command	SW Command
5190	1	1
5230	2	2
5270	Only in Auto mode	Only in Auto mode
5310	Only in Auto mode	Only in Auto mode
5510	Only in Auto mode	Only in Auto mode
5550	Only in Auto mode	Only in Auto mode
5590	X	Only in Auto mode
5630	X	Only in Auto mode
5670	Only in Auto mode	Only in Auto mode
5755	3	X
5795	4	X
Automatic	5-9	5-9

### 2.1.9 IR blaster

AMN35254 support PWM interface to IR blaster via audio 2.5mm jack, for mechanical dimensions of the audio jack follow the datasheet <http://www.cui.com/pdffiles/SJ-2523-SMT.pdf>, Silk number: J15.

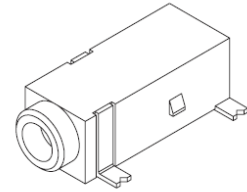

### 2.1.10 Audio AUX

The External audio connected via 2.5mm jack, for mechanical dimensions of the audio jack follow the datasheet <http://www.cui.com/pdffiles/SJ-2523-SMT.pdf>, Silk number: J16.

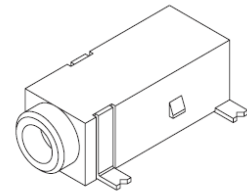

### 2.1.11 USB

There is a USB connector on board that is connected to the application uC.

This will be used for software upgrade through WHDI monitor.

USB type: USB mini-B connector, Silk number J18.

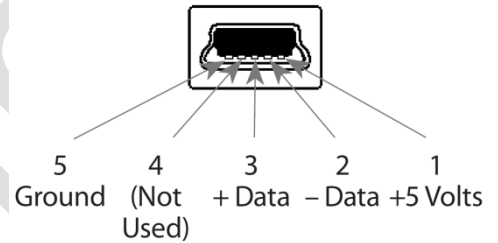

Preliminary

### 2.1.12 External On/Off switch connector

This connector is used for external On/Off switch, Pin 1 is VDD, Pin 2 is Power Enable.

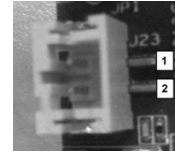

### 2.1.13 I2C connector

I2C Host interface connector is used for transferring I2C protocol message between the host chip (Micro Controller STM32F103) and the slave component.  
Pin-1: 3.3v, Pin-2: SCL Pin-3: SDA Pin-4: GND

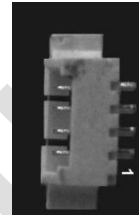

## 2.2 Antennas

This module is authorized to use only with the RP-SMA external antennas with 5dBi gain or less.

## 2.3 Block diagram of the TX AMN35254

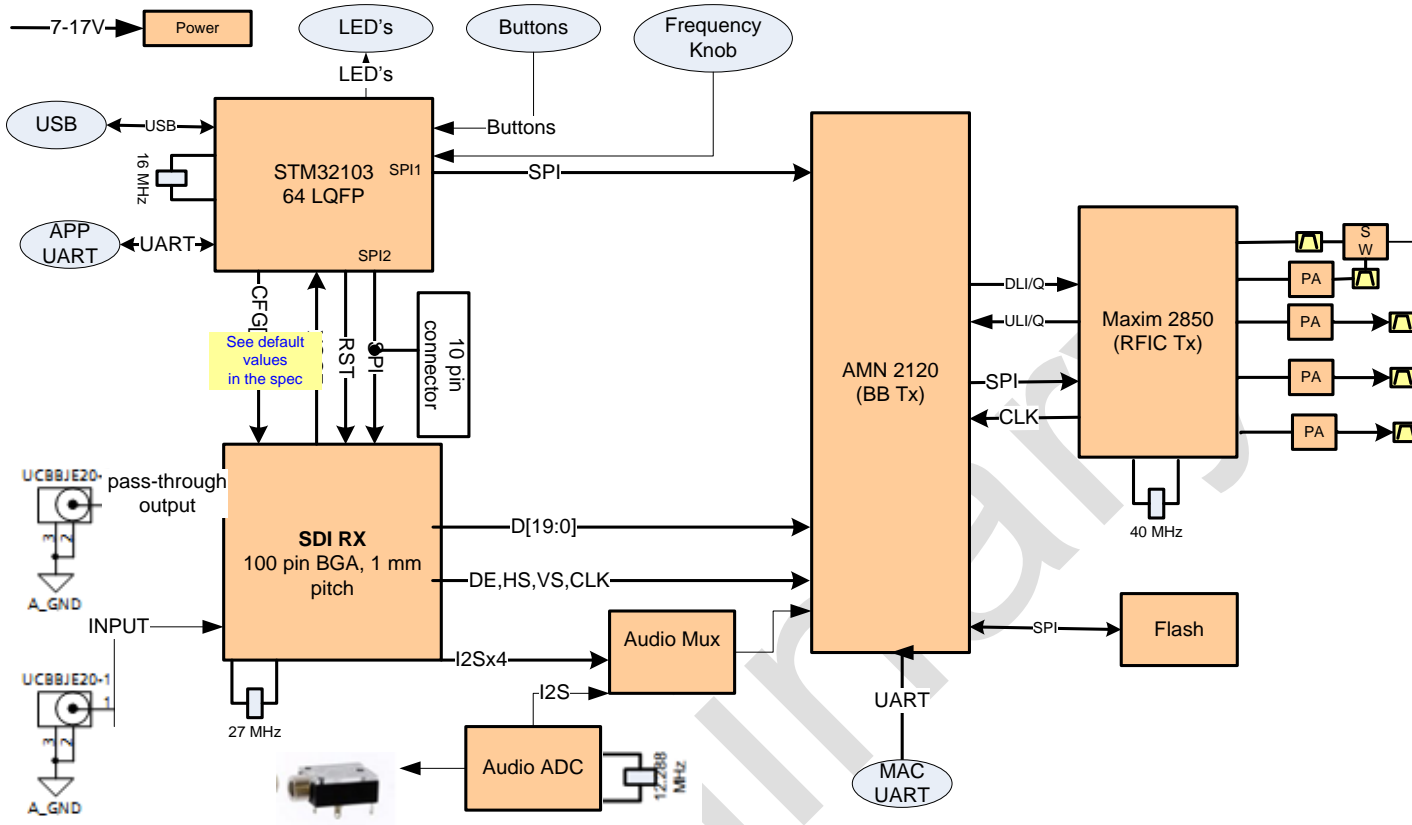

Figure 2: Tx - AMN35254 BLOCK DIAGRAM

## Chapter 3

# FCC Caution

Any changes or modifications not expressly approved by the responsible party could void the user's authority to operate this equipment.

**Notice:**

This module in its final integration requires the end-product to continue to comply with DFS requirements. A class II permissive change may be required for operation not already described in the FCC Grant filing.

**OEM Labeling Requirements**

Notice: The OEM of final integrator must ensure that FCC labeling requirements are met.

For a host using this module, if (1) the module's FCC ID is not visible when installed in the host, or (2) if the host is marketed so that end users do not have straightforward commonly used methods for access to remove the module so that the FCC ID of the module is visible; then an additional permanent label referring to the enclosed module should be used, with the following contents:

Company Name

MODEL:

Contains Model: AMN35254, FCC ID:VQSAMN35254

This device complies with Part 15 of the FCC Rules. Operation is subject to the following two conditions:

- (1) This device may not cause harmful interferences, and
- (2) This device must accept any interference received, including interference that may cause undesired operation.

The host OEM user manual must also contain clear instructions on how end users can find and/or access the module and the FCC ID.

The applicable usage is to be used as a wireless device, connected to the back of a professional camera and transmitting live video, coming from BNC connectors

**NOTE:**

This equipment has been tested and found to comply with the limits for a Class B digital device, pursuant to part 15 of the FCC Rules. These limits are designed to provide reasonable protection against harmful interference in a residential installation. This equipment generates, uses and can radiate radio frequency energy and, if not in-stalled and used in accordance with the instructions, may cause harmful interference to radio communications. However, there is no guarantee that interference will not occur in a particular installation.

**FCC Radiation Exposure Statement**

This equipment complies with FCC RF radiation exposure limits set forth for an uncontrolled environment.

This transmitter must not be co-located or operating in conjunction with any other antenna or transmitter.

This equipment complies with Part 15 of the FCC Rules. Operation is subject to the following two conditions:

- (1) This device may not cause harmful interference, and
- (2) This device must accept any interference received, including interference that may cause undesired operation.

The antenna used for transmission must be installed to provide a separation distance of at least 20cm from all persons and must not be co-located or operating in conjunction with any other antenna or transmitter.





Preliminary