



AmpWave™ 11Mbps Central Site Installation

Figure 4 shows a block schematic of the installation procedure for the Central Site Ampwave™ Installation.

Your Kit should include the following equipment:

- A. AMP 1124BTS – Base Station (1) is provided with a 120vac to 12V D.C. to D.C. converter ADC-12AP-120 (2). The BTS is mounted into standard 19” Rack using the BTS mounting sockets on the front of the unit (3). Connect the RJ45 ethernet cable (4) to the Ethernet socket at the back of the AMP11240BTS (Access Point) and the other end to your hub via the cross over cable. Connect the DC/DC converter to a 120vac socket and the other to the AMP1124BTS after the test of the installation is complete.
- B. 2-foot length of Stress Relief Cable (5) is connected to the reverse SMA connector of the AMP11240BTS. This stress relief provides stress relief between the large LMR400 Cables with N Connectors. In between the stress relief cable and the 100’ large LMR400 cable the DC Injector (7) is connected. The DC Injector is directional and is clearly marked as to the orientation for mounting the unit. An N type, male to male adapter (6) is required to be connected between the stress relief cable and the D.C. Injector.
- C. The D.C. Injector is used to supply +12V to the tower top Amplifier, AMP2425-27S. A 120vac to 12v converter ADC-12-AMP-120 (8) is supplied with the kit. Connect the line cord (9) of the converter to a 120vac socket. Connect the other end to the D.C. Injector after the installation is complete.
- D. LMR400 – this cable (10) is supplied with the kit and has two N-type male connectors at each end.
- E. The Bi-directional Amplifier, AMP2425-27 (11) is supplied with the kit and has 2 mounting brackets which connect the amplifier to the Mast – See Figure 2 for the installation directions of the Amplifier in detail. The Amplifier is directional and is clearly marked as to the orientation for mounting the unit.
- F. A short 6” length of LMR400 cable (12) is used to connect to the Lightning Arrester (13). The lightning Arrester must be suitable grounded.
- G. Finally the 10 dBi Omni Antenna (15), or optional antennas is connected to the lightning arrester with a N- type male to male adapter cable (14) which is provided with the kit. The optional antennas are:
 - a. AOM5
 - b. AOM8

- c. INET-OMNI-10
- d. INET-ANT-15
- e. APN-7

The mounting instructions for the 10 dBi OMNI, AOM10 are detailed as illustrated in Section B.

Mounting Instructions for the remainder of the AMPDNET™ antennas are provided with the antennas.

Figure 4

The Central Site Kit

1. AMP11240BTS – Base Station
2. ADC-12AP-120 – 120vac to 12v D.C. to D.C. Converter
3. Mounting Sockets
4. RJ45 Ethernet Cable
5. Stress Relief Cable
6. N- type Male-to-Male Adapter
7. DC Injector
8. ADC-12AMP-120 - 120vac Converter
9. Line Cord
10. LMR400
11. AMP2425-27S
12. LMR400 Cable
13. Lightning Arrestor
14. N-type Male-to-Male Adapter Cable
15. Antenna

The FCC warning relate to all Antennas used. Please refer to instructions in your kit.

WARNING: The AMPDNET™ Antenna should be installed only by an experienced antenna installer familiar with local building and safety codes and, wherever necessary, licensed by appropriate government regulatory bodies. Failure not to do so, may void the Product Warrantee, as well as expose the end user to legal and financial liabilities. Amplidyne, Inc., it's agents, resellers, or distributors, are not liable of injury, damage or violation of government regulations associated with the installation of the antenna.

The installer is responsible for ensuring that the public is not exposed to radio energy levels in excess of the FCC guidelines. Those guidelines imply that no human may conceivably be found within one foot of the front of the antenna. If such a situation is likely to occur, the installer is responsible for placing the appropriate caution signs to warn the public. Amplidyne, Inc., it's agents, resellers, or distributors are not liable for exposure to excessive RF energy levels due to improper antenna installation.

The Maximum Permissible Exposure guidelines are 1 foot (30cm) for the AMPDNET™ unit, as based on the National Council on Radiation Protection and Measurement (NCRP). If the antenna is in an accessible area, an appropriate warning sign must be installed in the appropriate place by the installer.

WARNING: Using an antenna or cable other than those supplied or recommended for use with the AMPDNET™ units, whether installer indoors or outdoors, could cause degradation of the system and could void your authority to operate this equipment. In addition, the use of unauthorized antennas or external amplifiers violates Federal Law and FCC's regulations. This may void the Product Warranty, as well as expose the end user to legal and financial liabilities.

WARNING: The AMPDNET™ Antenna emits high radio frequency energy levels. In order to comply with FCC RF Exposure requirements the antenna must be installed in a manner that will provide a minimum separation distance of 1 foot, (30 cm) between the antenna and all persons.

Example of Omni Directional

The Omni directional antenna available for use with the AMPDNET™ Central Site equipment is intended for external mounting and should be used when full 360-degree coverage is desired. When this antenna is mounted on a mast, it must be located as high as possible in order to avoid any other object located beside it. The OMNI antenna has a very narrow vertical beam width. Both the height and distance separation between the 2 sites must be taken into consideration when selecting the antenna in order to maximize the coverage area.

Following are the steps required to install the antenna for the AMPDNET™ System.

To install the Omni Antenna:

1. Mount the antenna using the enclosed brackets, following the instructions included with the antenna and cable kit that you purchased.

WARNING: AMPDNET™ Antenna should be installed only by experienced antenna installers familiar with local building and safety codes, and wherever necessary, licensed by appropriate government regulatory bodies. Failure to do so may void the Product Warrantee as well as expose the end user to legal and financial liabilities. Amplidyne, Inc., it's agents, resellers, or distributors, are not liable for injury, damage or violation of government regulations associated with the installation of the antenna.

POWER COMPLIANCE

The system, if required by regulation, performs transmits power adjustment based on the installed antenna and cable. The antenna filter unit, if required, goes between the tension release cable and the antenna cable and is used to limit the AMPDNET™ emissions to comply with you country's requirements.

Make sure that you enter the correct antenna and cable parameters in the antenna configuration software so that it complies with your country's requirements. In addition, do not attempt to dispense with the use of the filter in conjunction with the AMPDNET™ units. Incorrect antenna parameters and/or dispensing with the use of the filter may cause the system to malfunction and invalidate your warranty.

LIGHTNING PROTECTION

It is highly recommended that you connect the shield/enclosure of the antenna and/or cable to a ground before the entrance to the building. This will provide some lightning arrestor. Such devices protect the AMPDNET™ Central Site, as well as the life of any person in contact with the wireless access unit if the antenna is struck by lightning.

The optional AMPDNET™ lightning arrestor has the same connector arrangement as the antenna cable segment (male/male). As a result, it can be installed between any two-cable segments (the antenna and the tension release cable are also considered cables for this purpose). However, the best location for the arrestor is just before the cable's entrance to the building. In either case, the arrestor must be mounted outside the building. The arrestor that comes in the Central site Kit is self-resetting, meaning that maintenance is not needed, even following a lightning strike. Follow the installation instructions provided for the arrestor and ensure that the grounding solution is in accordance with these instructions.

Warning: A lightning arrestor should be installed on any antenna mounted outdoors. Failure to do so may void the product. Amplidyne, Inc., it's agents, resellers, or distributors, are not liable for injury or damage caused by lightning striking the antenna.

SECTION B

Installing Instructions

Rev. 1

Omnidirectional Antennas

Mounting:

For optimal performance these antennas must be mounted on top of the antenna supporting structure (tower, pole, etc.) above all other objects (lightning rod, obstruction lights, other antenna, etc.). In areas where severe lightning can be a problem, a thin lightning rod can be mounted several wave lengths away from the antenna. If the antenna is mounted on the side of the tower or above the top of the tower but in the vicinity of other antennas or a lightning rod, then this will result in a “scalped” azimuth pattern with nulls or a slightly offset pattern.

Some antenna models have a very narrow beamwidth and must be mounted carefully. The antennas must be mounted in a true vertical (plumb) position in order to assure omnidirectional coverage in the horizontal (azimuth) plane. In a point-to-multipoint system where a high gain antenna is installed on top of a high mountain, the system designer should make sure that the signal does not merely “pass over” the close-in subscribers situated in the valley below.

The antennas are mounted to a customer supplied support mast having an outside diameter of 1.75 to 4.0 inches (45 to 102 mm) using the clamps supplied with the antenna.

Lightning Protection:

The antenna is a DC ground for lightning protection. The mounting clamps “ground” the antenna to the support mast. The support mast must in turn, be grounded using practices supplied/approved by the customer.

Weatherproofing:

All connections between the antenna connector and the transmission line must be weatherproofed. This can be done using the procedure outlined in application No.2.

Drainage:

Since the radome on the antenna is not pressurized, there is a drain hole in the connector base plate. This drain must be kept open so that any moisture accumulating inside the radome will be able to drain properly.

**NOTE: THESE MODELS CANNOT BE MOUNTED IN THE INVERTED POSITION.
ANTENNAS MUST BE MOUNTED WITHIN 1 DEGREE VERTICAL.**

MOUNTING DIAGRAM
Rev. 1

NOTE: a) Clamps supplied will mount to a 1.75"-4" pipe.

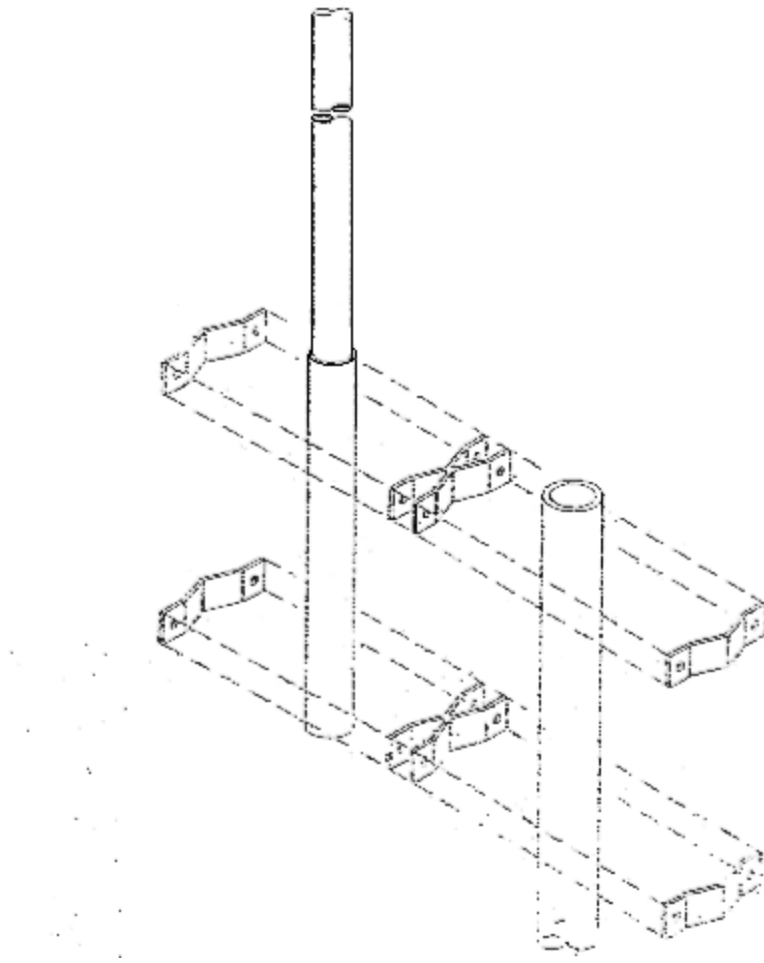

MOUNTING DIAGRAM (TOP VIEW)

NOTE: a.) Clamps supplied will mount to a 1.75" – 4" O.D. Pipe.

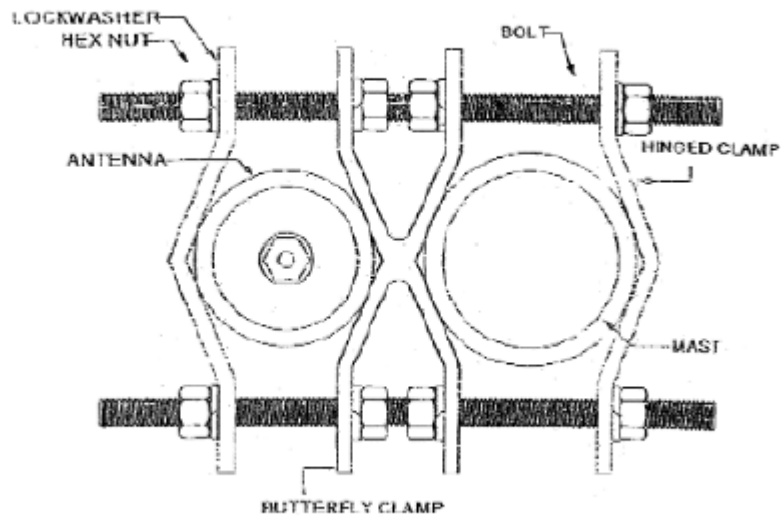

Most antenna problems are caused by coaxial cable connections that loosen due to vibration, allowing moisture to penetrate the connector interface. We recommend that all out door cable connections be weatherproofed using a procedure similar to the one described below. To facilitate the task the sealant tape is supplied with each antenna shipped, (the customer is responsible for providing the electrical tape).

Step 1.

Beginning as shown in Figure 1 by overlapping half-width, wrap sealant tape over entire connection.

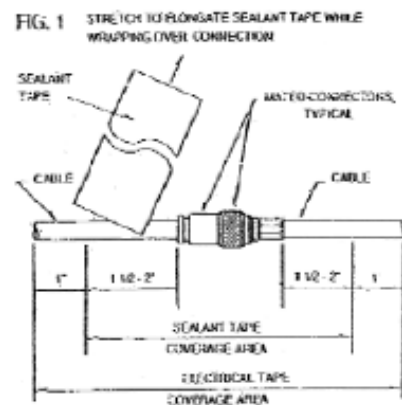

Step 2.

Firmly press on the sealant tape.
Sealing it to the connection, itself and the cable jackets, as shown in Figure 2.

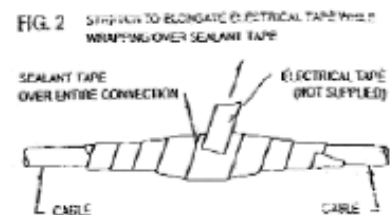

STEP 3.

While overlapping half-width, wrap electrical tape (not supplied) over the entire sealant tape connection. While stretching tape, begin at one end of formed sealant tape and work towards other end approximately one inch beyond end of sealant tape. Insure tight electrical tape coverage over cable jacket. Without breaking electrical tape, reverse direction and wrap to other end, again extending approximately one-inch beyond end sealant tape. Again insure tight coverage onto cable jacket. Reverse direction again and wrap electrical tape to center of connection and cut.

FIGURE 3
ELECTRICAL TAPE WRAPPED TIGHTLY AGAINST
CABLE JACKET, TYPICAL BOTH ENDS

