

Amp Wave™

Amp D Link™ Outdoor Central Site Installation

Figure 1 shows a block schematic of the installation procedure for the AmpDLink™ central site.

Your kit should include the following equipment:

- A. AMP 2024 AP – Access Point {1} is provided with a 120vac to 12v D.C. to D.C. converter ADC-12AP-120. {2}. The Access Point is mounted to a wall or plywood panel using the 2 mounting sockets on the back of the unit.

A 3 foot RJ 45 Cable {3} is provided with the unit as well as a 6" length of "Cross Over" cable. {4} Connect the RJ 45 ethernet cable to the ethernet socket at the back of the AMP 2024 AP (Access point) and the other end to your hub via the cross over cable.

Connect the DC/DC converter to a 120vac socket and the other to the AMP2024AP after the test of the installation is complete.

- B. 2-foot length of Stress Relief Cable {5} is connected to the reverse SMA connector of the AMP 2024AP. This stress relief provides stress relief between the large LMR 400 cables with N connectors. In between the stress relief cable and the 100' large LMR 400 cable the DC injector {7} is connected. The DC injector is directional and is clearly marked as to the orientation for mounting the unit. An N type, male-to-male adapter, {6} is required to be connected between the stress relief cable and the D.C. injector.
- C. The D.C. injector is used to supply +12v to the tower top amplifier AMP2425-27. A 120vac to 12v converter ADC-12-AMP-120 {8} is supplied with the kit. Connect the line cord {9} of the converter to a 120vac socket. Connect the other end to the D.C. injector after the installation is complete.
- D. LMR 400 - this cable {10} is supplied with the kit and has two N type male connectors at each end.
- E. The Bi directional Amplifier AMP 2425-27 {11} is supplied with the kit and has 2 mounting brackets which connect the amplifier to the MAST- See Figure 2 for the installation directions of the Amplifier in detail. The Amplifier is directional and is clearly marked as to the orientation for mounting the unit.
- F. A short 6" length of LMR 400 cable {12} is used to connect to
- G. Lightning arrestor {13}, The lightning arrestor must be suitably grounded.
- H. Finally the 10dBi OMNI antenna {15} is connected to the lightning arrestor with a N type male to male adapter cable {14} provided with the kit.

The mounting instructions for the 10dBi OMNI are detailed as illustrated in Section B below.

The Amp D Lan™ Kit

- (1) Access Point AMP 2024 AP
- (2) DC Converter _____
- (3) RJ45 Cable
- (4) Cross over cable
- (5) stress relief cable
- (6) DC Injector
- (7) N-Type Male-to-Male adapter
- (8) DC Converter
- (9) AC Line cord
- (10) 100 foot LMR-400 cable
- (11) AMP2425-27 Bi directional amplifier
- (12) 6 inch LMR-400 Cable
- (13) Lightning surge arrestor
- (14) N-Type Male-to-Male adapter
- (15) 10 dB OMNI Antenna

Antenna Notes

Omni Directional Antennas

The Omni directional antenna available for use with the AmpDNet™ central site equipment is intended for external mounting and should be used when full 360 degree coverage is desired. When this antenna is mounted on a mast, it must be located as high as possible in order to avoid any other object located beside it. The OMNI antenna has a very narrow vertical beam width.

Both the height and distance separation between the 2 sites must be taken into consideration when selecting the antenna in order to maximize the coverage area.

The installer is responsible for ensuring that the public is not exposed to radio energy levels in excess of the FCC guidelines. Those guidelines imply that no human may conceivably be found within one foot of the front of the antenna. If such a situation is likely to occur, the installer is responsible for placing the appropriate caution signs to warn the public. Amplidyne, Inc., its agents, resellers, or distributors, are not liable for exposure to excessive RF energy levels due to improper antenna installation.

The Maximum Permissible Exposure guidelines are 1 foot (30 cm) for the AmpDNet™ unit, as based on the National Council on Radiation Protection and Measurement (NCRP). If the antenna is in an accessible area, an appropriate warning sign must be installed in the appropriate place.

Warning: Using an antenna or cable other than those supplied or recommended for use with the AMPDNet™ units, whether installed indoors or outdoors, could cause degradation of the system and could void your authority to operate this equipment. In

addition, the use of unauthorized antennas or external amplifiers violates Federal law and FCC's regulations. This may void the Product Warranty, as well as expose the end user to legal and financial liabilities.

Warning: The AmpDNet™ antenna emits high radio frequency energy levels. In situations where unauthorized persons may approach within 1 ft (30 cm) of the front of the antenna, an appropriate warning sign should be placed near the AmpDNet™ antennas.

Antenna Installation Procedure

Following are the steps required to install the antenna for the AmpDNet™ System.

To install the Omni antenna:

1. Mount the antenna using the enclosed brackets, following the instructions included with the antenna and cable kit that you purchased.

WARNING: The AmpDNet™ antenna should be installed only by experienced antenna installers familiar with local building and safety codes and, wherever necessary, licensed by appropriate government regulatory bodies. Failure to do so may void the Product Warrantee as well as expose the end user to legal and financial liabilities. Amplidyne, Inc., its agents, resellers, or distributors, are not liable for injury, damage or violation of government regulations associated with the installation of the antenna.

Power Compliance

The system, if required by regulation, performs transmits power adjustment based on the installed antenna and cable. The antenna filter unit, if required, goes between the tension release cable and the antenna cable and is used to limit the AmpDNet™ emissions to comply with your country's requirements.

Make sure that you enter the correct antenna and cable parameters in the antenna configuration software so that it complies with your country's requirements. In addition, do not attempt to dispense with the use of the filter in conjunction with the AmpDNet™ units. Incorrect antenna parameters and/or dispensing with the use of the filter may cause the system to malfunction and invalidate your warranty.

WARNING: Willfully entering incorrect values in the antenna parameters software and/or avoiding the use of an antenna filter violate unlicensed band radio frequency regulations. This may void the Product Warranty, as well as expose the end user to legal and financial liabilities.

Lightning Protection

It is highly recommended that you connect the shield/enclosure of the antenna and/or cable to a ground before the entrance to the building. This will provide some lightning arresstor. Such Devices protect the AmpDNet™ AMP2024AP, as well as the life of any person in contact with the wireless access unit if the antenna is struck by lightning.

The optional AmpDNet lightning arresstor has the same connector arrangement as the antenna cable segment (male/male). As a result, it can be installed between any two-cable segments (the antenna and the tension release cable are also considered cables for this purpose). However, the best location for the arresstor is just before the cable's entrance to the building. In either case, the arresstor must be mounted outside the building.

The arresstor that you can purchase with the AMP2024AP is self-resetting, meaning that maintenance is not needed, even following a lightning strike. Follow the installation instructions provided for the arresstor and ensure that the grounding solution is in accordance with these instructions.

Warning: A lightning arresstor should be installed on any antenna mounted outdoors. Failure to do so may void the product. Amplidyne, Inc., its agents, resellers, or distributors, are not liable for injury or damage caused by lightning striking the antenna.

Installation Instructions

Rev. 1

Omnidirectional Antennas

Mounting:

For optimal performance these antennas must be mounted on top of the antenna supporting structure (tower, pole, etc.) above all other objects (lightning rod, obstruction lights, other antennas, etc.) In areas where severe lightning can be a problem, a thin lightning rod can be mounted several wave lengths away from the antenna. If the antenna is mounted on the side of the tower or above the top of the tower but in the vicinity of other antennas or a lightning rod, then this will result in a "scalped" azimuth pattern with nulls or a slightly offset pattern.

Some antenna models have a very narrow beamwidth and must be mounted carefully. The antennas must be mounted in a true vertical (plumb) position in order to assure omnidirectional coverage in the horizontal (azimuth) plane. In a point-to-multipoint system where a high gain antenna is installed on top of a high mountain, the system designer should make sure that the signal does not merely "pass over" the close-in subscribers situated in the valley below.

The antennas are mounted to a customer supplied support mast having an outside diameter of 1.75 to 4.0 inches (45 to 102 mm) using the clamps supplied with the antenna.

Lightning Protection:

The antenna is at DC ground for lightning protection. The mounting clamps "ground" the antenna to the support mast. The support mast must in turn be grounded using practices supplied/approved by the customer.

Weatherproofing:

All connections between the antenna connector and the transmission line must be weatherproofed. This can be done using the procedure outlined in application No. 2.

Drainage:

Since the radome on the antenna is not pressurized, there is a drain hole in the connector base plate. This drain must be kept open so that any moisture accumulating inside the radome will be able to drain properly.

**NOTE: THESE MODELS CANNOT BE MOUNTED IN THE INVERTED POSITION.
ANTENNAS MUST BE MOUNTED WITHIN 1 DEGREE OF VERTICAL.**

MOUNTING DIAGRAM

Rev. 1

NOTE: a) Clamps supplied will mount to a 1.75" - 4" pipe.

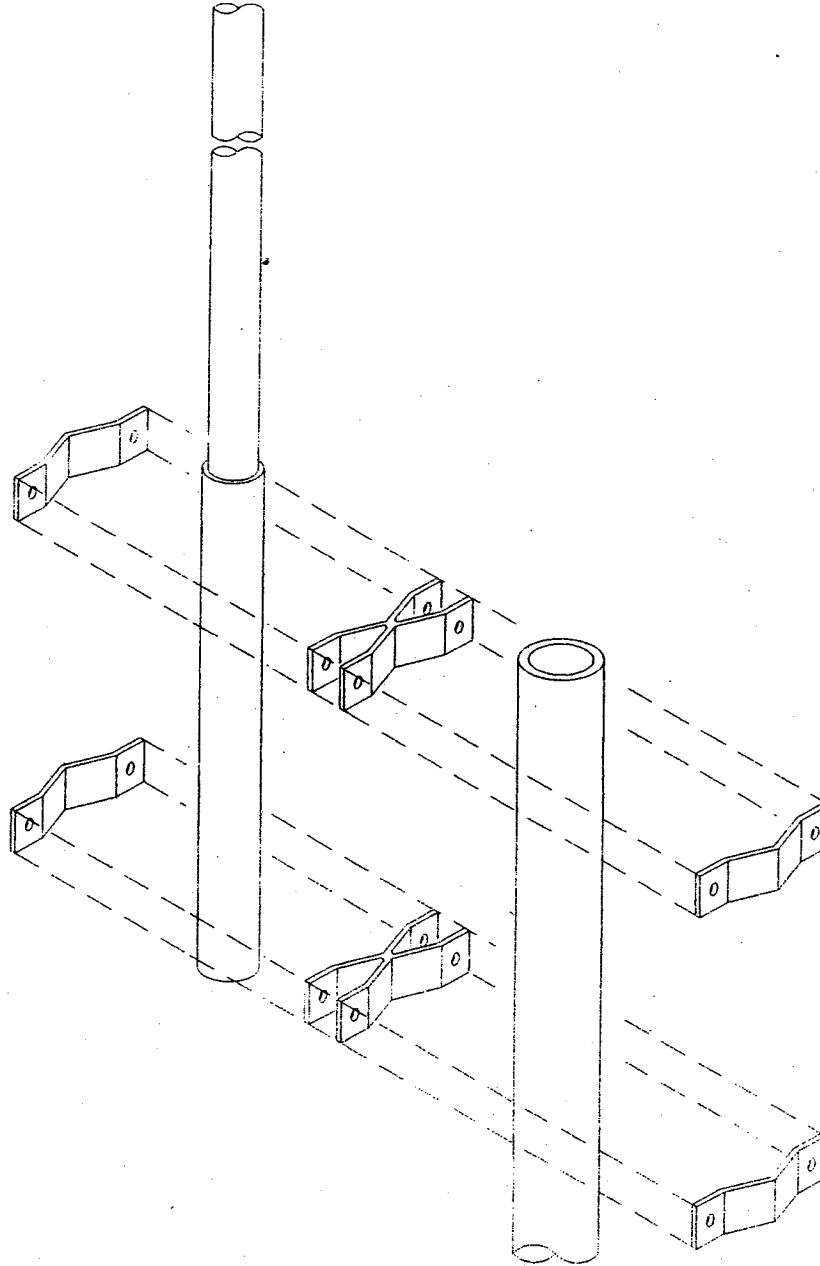

MOUNTING DIAGRAM (TOP VIEW)

NOTE: a) Clamps supplied will mount to a 1.75" - 4" o.d. pipe.

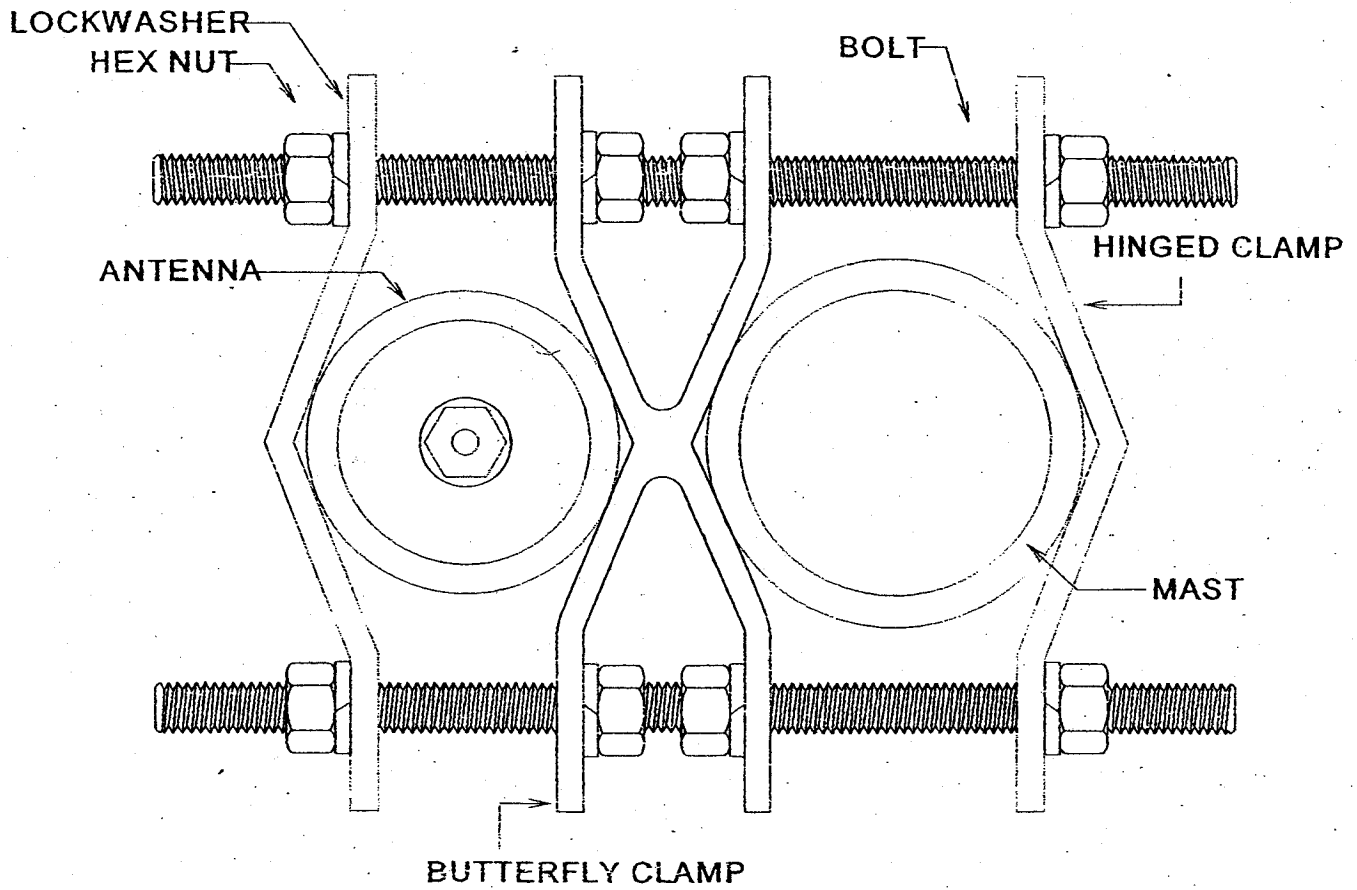

Most antenna problems are caused by coaxial cable connections that loosen due to vibration, allowing moisture to penetrate the connector interface. We recommend that all outdoor cable connections be weatherproofed using a procedure similar to the one described below. To facilitate the task, the sealant tape is supplied with each antenna shipped (the customer is responsible for providing the electrical tape).

FIG. 1 STRETCH TO ELONGATE SEALANT TAPE WHILE WRAPPING OVER CONNECTION

Step 1.

Beginning as shown in Fig. 1, by overlapping half-width, wrap sealant tape over entire connection.

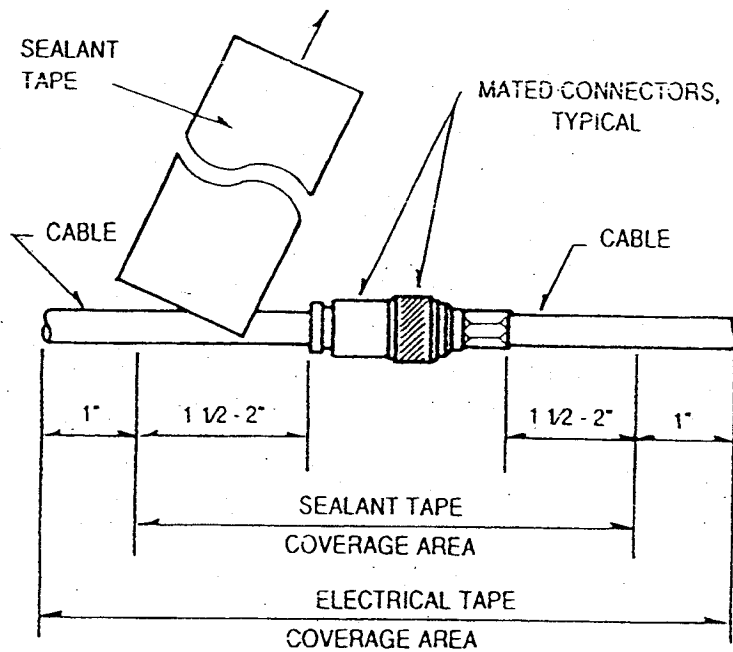

Step 2.

Gently press on the sealant tape, forming it to the connection, itself and the cable jackets, as shown in Fig. 2

FIG. 2 STRETCH TO ELONGATE ELECTRICAL TAPE WHILE WRAPPING OVER SEALANT TAPE

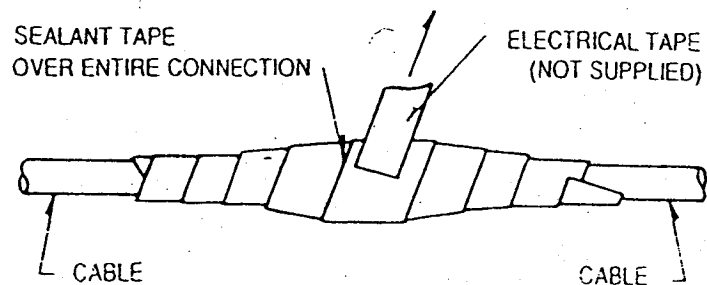

Step 3.

By overlapping half-width, wrap electrical tape (not supplied) over the entire sealant tape connection.

While stretching tape, begin at centre of formed sealant tape and wrap towards one end approximately one inch beyond end of sealant tape. Insure tight electrical tape coverage onto cable jacket. Without breaking electrical tape, reverse direction and wrap to other end, again extending approximately one-inch beyond end of sealant tape. Again insure tight coverage onto cable jacket. Reverse direction again and wrap electrical tape to centre of connection and stop.

FIG. 3 ELECTRICAL TAPE WRAPPED TIGHTLY AGAINST CABLE JACKET, TYPICAL BOTH ENDS.

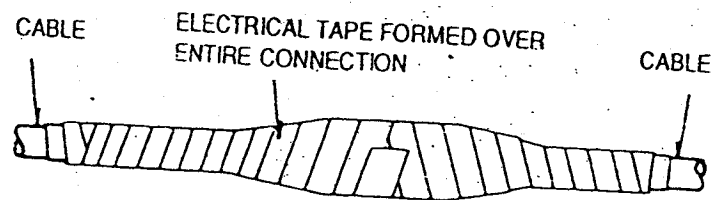

Recommended reading:
"How to Weatherproof Coaxial Connectors", by John Midkiff,
Mobile Radio Technology Magazine,
April 1990 Issue

Parameter	Symbol	Conditions	Min	Type	Max	Units
Specified Frequency Range	F		2300	TYP	2500	MHz
Antenna Gain	G	APG 15 APG 19 APG24		15 19 24		dBi
Input Return Loss	S ₁₁	50 ohm system		-14	-12	dB
Cross Polarization Rejection	CP			< -19		dB

Absolute Maximum Ratings

Characteristic	Symbol	Value	Units
Power Level	P _{max}	40	dBm
Operating Temperature	T	-45 to +70	°C

Mechanical Specifications

Antenna Reflector: Wire welded construction



Top View

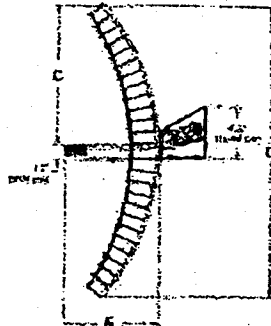

Side View

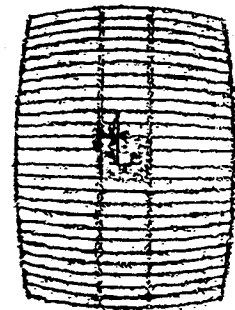

Rear View

	A		B		C		D		E	
	in.	cm.	in.	cm.	in.	cm.	in.	cm.	in.	cm.
APG15	11.5	29.21	6.5	16.51	6.4	16.26	14.0	35.56	7.2	18.29
APG19	16.7	42.42	9.4	23.88	11.2	28.45	23.6	59.95	9.4	23.87
APG24	28.0	71.12	11.4	28.96	16.4	41.66	34.0	86.36	16.0	40.64

Approximate Installed Weight including PMPF-1

APG-15	2.6 lbs (1.18 kg)
APG-19	3.9 lbs (1.77kg)
APG-24	8.2 lbs (3.72 kg)

AMPD Lan™ Amplifier AMP 2425-27S

Mounting Instructions for The Amplifier AMP 2425-27S

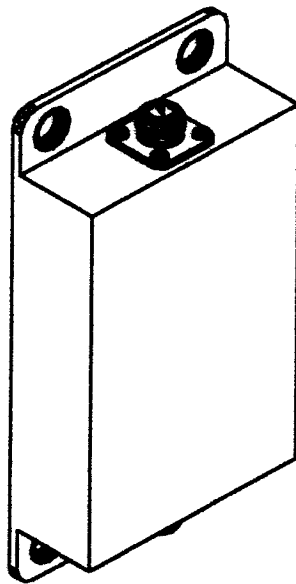
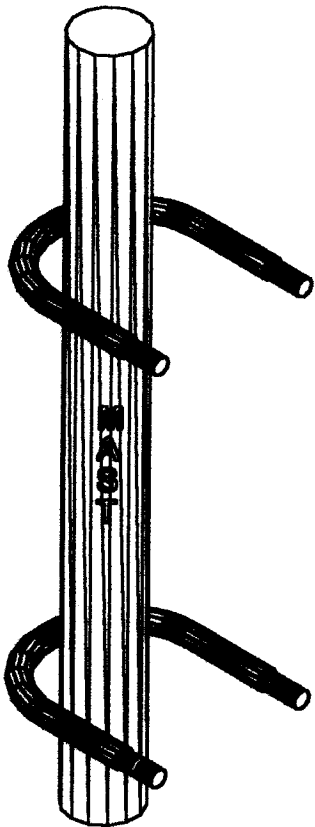

The amplifier is supplied with 2 stainless steel U bolts for mounting on to the mast. Do not use excessive force to tighten the bolts, which may cause problems on the RF connector on the amplifier. The amplifier is supplied with protection caps on the RF connectors and these must be kept until final installation to exclude moisture from the connectors. All connections should be weather sealed as per instructions under the installation manual.

MOUNTING INSTRUCTION