

AMPY 5252 Meter

Meter user manual

Version 1.1

AMPY
Metering

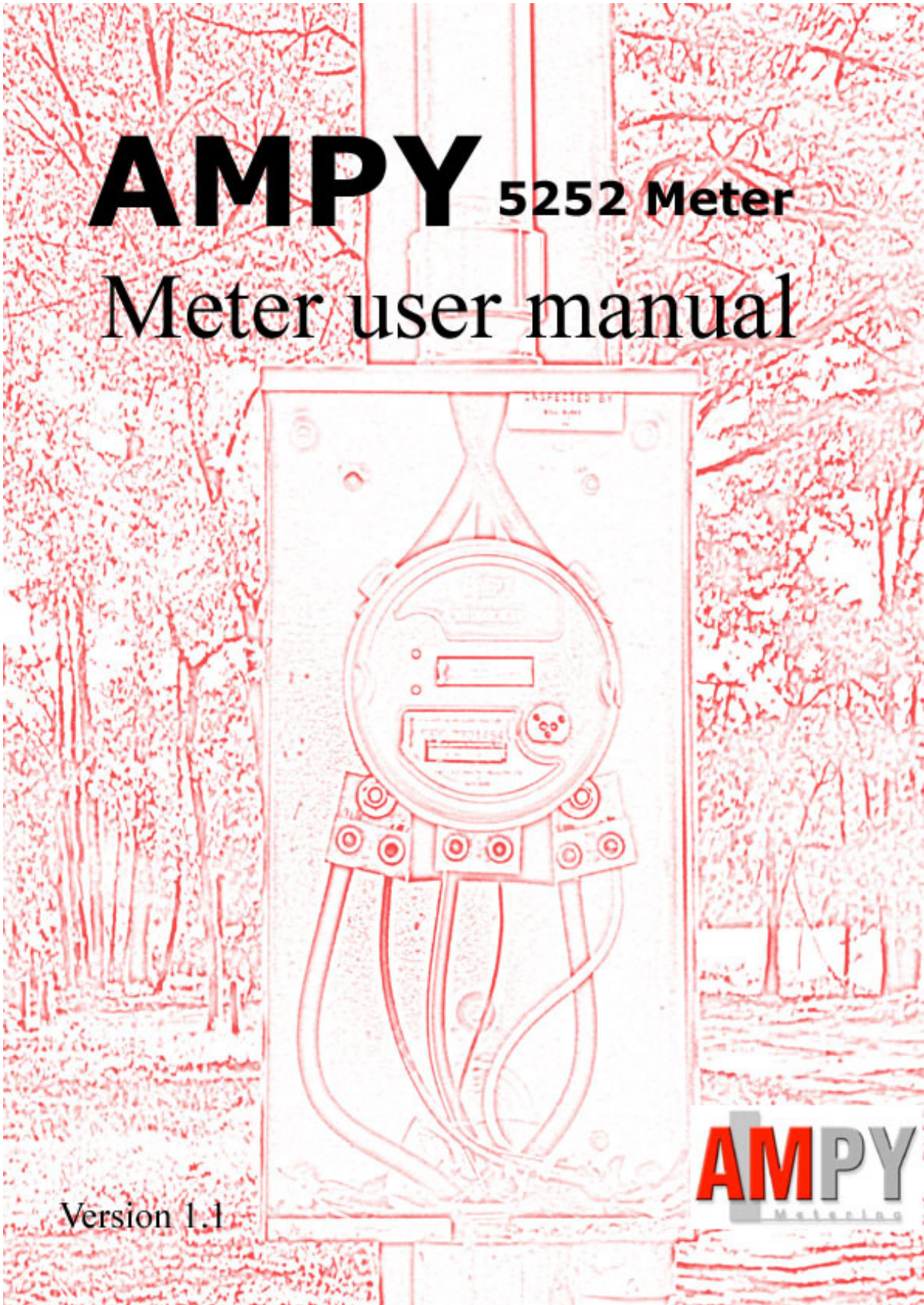

5252 Meter Functionality User Manual
Ampy Metering Ltd
Version 5252 1.1

© Copyright Ampy Metering Ltd, 1 Lysander Drive Northfields Industrial Estate Market Deeping Peterborough PE6 8FB

The information contained in this document is the property of the authors. It may not be copied, stored on an information retrieval system or communicated by electronic mail or other means without the express permission of the authors.

Table of Contents

TABLE OF CONTENTS	III		
AMPY 5252 METER FUNCTIONS	1		
METER OVERVIEW	2		
APPROVAL STANDARDS	2		
ELECTRICAL PARAMETERS	2		
PERFORMANCE REQUIREMENTS	3		
METROLOGY OUTPUT LED	3		
SUPPLY LOSS REPORTING (LAST GASP)	3		
OPTICAL PORT	4		
METER DISPLAYS	5		
DISPLAYED INFORMATION	6		
OPERATION ICONS	6		
ENERGY AND INFORMATION DISPLAYS	7		
TIME AND DATE DISPLAYS	8		
TAMPER DISPLAYS	8		
PREPAY DISPLAYS	9		
WARNING AND ENGINEERING DISPLAYS	10		
DISPLAY CYCLING	11		
EXTENDED DISPLAY	11		
LCD BOTTOM-NUMBER INDICATIONS USED BY PLC COMMUNICATIONS	12		
LCD ICON INDICATORS	13		
RATES AND TARIFFS	14		
TIME OF USE RATE SWITCHING AND POWER BAND TARIFFS	15		
TARIFF RATE PLAN/ DEMAND RESPONSE INDICATION ASSIGNMENT	16		
BLOCK TARIFF POWER SWITCH			
THRESHOLD VALUES	18		
TARIFF PLAN	19		
DEMAND RESPONSE INDICATION ASSIGNMENT	20		
METER OPERATION	21		
REAL TIME CLOCK	22		
DAYLIGHT SAVING	22		
PREPAYMENT OPERATION GENERAL HOLIDAYS	22		
SEASONAL NON DISCONNECT	23		
FRIENDLY NON-DISCONNECT	23		
TARIFF STORAGE	23		
FIXED CHARGES	23		
ACCOUNTANCY CONFIGURATION	24		
CREDIT TRANSACTIONS	24		
		CREDIT INFORMATION LOG	24
		DEMAND RESPONSE	24
		REMOTE DISCONNECT/RECONNECT	26
		SAFETY RECONNECTION	26
		METER TEST MODE (METROLOGY TESTING)	26
		FIELD TEST MODE	26
		PROFILING	27
		MAXIMUM DEMAND	27
		ENERGY REGISTRATION	27
		TAMPER DETECTION	27
		POWER OUTAGE REPORTING	28
		SPECIAL CONTACTOR OPERATION	28
		DATA LOGGING	28
		EMERGENCY TIME LOG	29
		SELF DISCONNECTS LOGGING	29
		DECOMMISSION / RE-COMMISSION DATA	29
		METER REGISTERS	31
		CREDIT/DEBT REGISTER	32
		MAXIMUM CREDIT REGISTER	32
		ACCOUNTANCY CONFIGURATION	32
		DECIMAL POINT CONFIGURATION	32
		MAXIMUM DEMAND PERIOD	32
		ACTIVE RATE	32
		KWH REGISTERS	32
		\$ PER UNIT FOR RATES 1 TO 4	32
		USAGE YESTERDAY	32
		\$ USAGE PER HOUR	33
		KW USAGE PER HOUR	33
		\$ USAGE TODAY	33
		\$ USAGE THIS MONTH	33
		\$ USAGE LAST MONTH	33
		ACTIVE FIXED CHARGE 1 AND 2	33
		FUTURE FIXED CHARGE 1 AND 2	33
		FUTURE FIXED CHARGE 1 AND 2	
		ACTIVATION DATES	33
		SEASONAL NON DISCONNECT START AND END DATE/TIME	33
		OPERATION MODE	33
		POWER FAIL COUNT	34
		WAKE UP REGISTER	34
		CREDIT TRANSFER REGISTER	34
		CREDIT HISTORY	34
		CREDIT INFORMATION (TRANSFER) LOG	34
		FRIENDLY DEBT REGISTER	34
		ENERGY REGISTRATION MODES	35

VOLTAGE REPORTING	36
COMMUNICATION	37
PERIODIC - DAILY READS	38
PERIODIC - MONTHLY READS	38
PERIODIC - TIME UPDATE	38
PERIODIC - LOAD PROFILE COLLECTION	38
INSTANTANEOUS - POWER OUTAGE REPORTING	39
INSTANTANEOUS - READ REQUEST	39
INSTANTANEOUS - DISCONNECT/RECONNECT REQUEST	39
INSTANTANEOUS – PREPAY TRANSACTION	39
INSTANTANEOUS REQUEST – CONFIG UPDATE	39
GLOBAL BROADCAST – DEMAND RESPONSE	40
DEFINITIONS	41

AMPY 5252 Meter functions

Functions of the 5252 Meter

C O N T E N T S

- Meter Overview
 - Approval Standards
 - Operational Requirements
 - Electrical Parameters
 - Performance Requirements
 - Metrology Output LED
 - Supply Loss Reporting
 - Optical Port
-

Meter Overview

This manual covers the Type 5252 Meter Radio based Tokenless prepay system for the North American market. The meter includes a 2 way radio component. This will allow the meter to provide Tokenless prepay, Demand response and remote disconnect when operating as a standard post paid meter.

The meter is a single phase and network meter measuring active energy across four time of use rates, is fitted with a disconnect switch for the disconnection of supply, radio module for communicating with a base station and PLC modem for communicating with the in-home unit. The in-home unit provides the customer usage information, demand response signaling and the ability to close the meters contactor after a reconnection command.

Approval Standards

Description	Document Number
Accuracy Tests and Internal influences	ANSI C.12.1
Electrical Safety Requirements of Equipment for Laboratory Use (Meter, US)	UL6101B-1
Electrical Safety of Measuring & Test Equipment, part1: General Requirements (Meter, CA)	CSA C2.22 No.1010-1
Code of Federal regulation, Title 47 Telecommunication Part 15 – Radio Frequency Devices	FCC Part 15 Carrier Current Devices & Digital Devices
Industry Canada interference causing Equipment Standard-Digital Apparatus & Carrier Current Devices	ICES-003 & ICES-006



The meter described in this guide emits radio frequency energy. Calculations show that at a distance of 20cm, the power density is below the FCC limits for RF radiation exposure.

This device complies with part 15 of the FCC Rules. Operation is subject to the following two conditions: (1) This device may not cause harmful interference, and (2) this device must accept any interference received, including interference that may cause undesired operation.

This device is specifically designed to be used under section 15.247 and 15.249 of the FCC rules and regulations. Any unauthorized modification or changes to this device may void the user's authority to operate this device

Electrical Parameters

The meter operates on a single phase, three wire circuit with a reference voltage of 120/240V, 60Hz. Meter Form 2S

The meter will also operate on a three wire network connection (two phases of a three phase four wire system) with a reference voltage of 120/208V, 60Hz. Meter Form 12S.

The meter when powered up will be fully operational with mains voltages above 176V.

The meter will power fail and shut down below 166V.

The reference frequency is 60Hz

The meter has a test amps rating of 30 Amps

The meter has a maximum rated current of 200A

Performance Requirements

The meter has been designed to have a minimum product life of 15 years.

Energy measurement accuracy is approved to class 200 (Cl 200).

The meter is approved to ANSI C12 and relevant UL (CSA) safety standards.

The operating temperature range: -30°C to $+70^{\circ}\text{C}$

The storage temperature range: -40°C to $+80^{\circ}\text{C}$

While on supply the meter's time is kept to within \pm 5minutes of local time at all times.

Metrology output LED

To indicate energy usage the meter optical port is fitted with an infrared LED. The LED flashes according to the energy recorded.

When registering energy the LED flashes at a rate of 1 pulse per Wh of energy recorded (1000 pulses kWh, 1 Kh).

The metrology LED will be permanently on when creep lock is active.

To give a visual indication of energy registration, an indicator flashing at the same rate as the metrology LED is shown on the display.

Supply Loss Reporting (Last Gasp)

If a voltage interruption of approx. 2 mains cycles in duration is detected, the meter will trigger a Power loss report to radio module.

The radio module will transmit to the Central System once an available transmission slot is detected.

If supply is restored following the interruption but before the message is sent, the meter will cancel the message to the Radio module. This will prevent messages being sent where the supply loss was of very short duration.

Optical Port

The Meter is fitted with an optical data port which meets the ANSI standard C12.18 Section 4.8 “Layer1 – Physical”. The optical probe is used for programming and data collection.

C O N T E N T S

- Displayed Information
 - Operational Icons
 - Energy and Information Displays
 - Time and Date Displays
 - Tamper Displays
 - Pre-Pay Displays
 - Warning and Emergency Displays
 - Display Cycling
 - Extended Display
 - LCD Bottom Numbers indication
 - LCD Icon Indicators
-

Meter Displays

Meter Display Information

Displayed Information

The meter has a cycling display which is configurable by the utilities. The meter display uses a set of 4 starburst characters, 7 seven-segment characters and specific icons to show operation and status of meter.

The display scroll rate is configurable in seconds by the Central System software.

The following diagram shows an example of the Meter display showing all functionality.

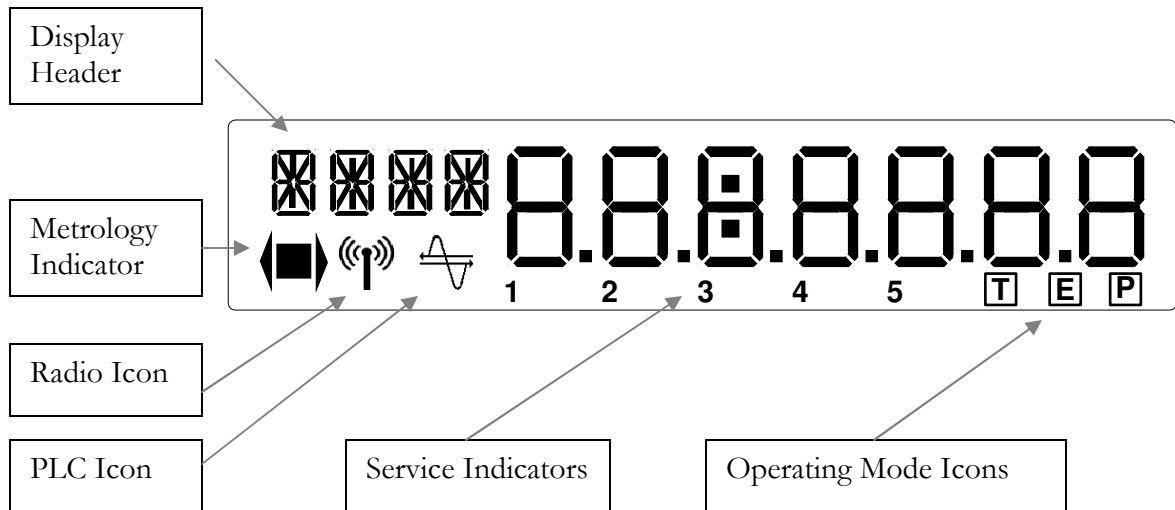



Operation Icons

 **Power Registration Icon** - Centre rectangle/square is shown if the contactor is closed when the meter is in either credit or prepayment mode.

The Centre rectangle/square will flash each time a Wh of energy has been consumed at same rate as metrology LED. The side triangles represent energy direction. NOTE: Initially only forward (RH) indicator will be used, reverse triangle is for future use.

 **Radio Reception Icon** - Radio icon will be shown when the meter is able to correctly hear and decode messages from a base station.

 **PLC Icon** - PLC icon will be shown when the meter is able to correctly hear and decode messages from a CIU.

 **Tamper Detection** - Icon is shown if meter detects tamper event. Icon is reset following a reset command from the system or optical port.

 **Prepayment Mode** - Icon is shown if meter is configured to prepayment mode

E **Emergency Code / Wake-up Indicator** - Symbol is shown if the meter has accepted a valid emergency e-code or is in a 10-minute wake-up period following a wake-up message from the CIU under battery power. During a wake up period the symbol will be flashed.

Energy and Information Displays

The Energy registers of the meter show 5 whole numbers with the option of 0, 1 or 2 decimal places unless configured to 3 decimal places of testing purposes via the optical port. The register will roll over to zero after 99999.99.

Rate registers are shown as -

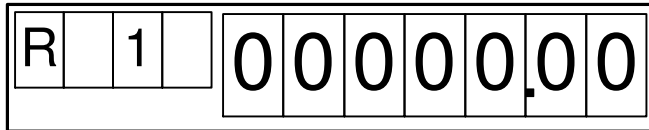

Total energy register – The total energy register displays the sum of rate 1 to 4 energy registers. The register will roll over to zero after 99999.99.

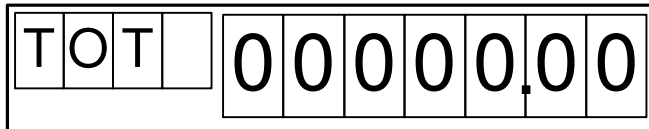

Active rate – The active rate will be shown by flashing the rate enunciator (configurable) on the active energy register.

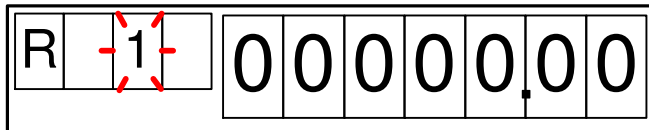

Received Energy – The meter will record any received (export/reverse) energy to a specific register.

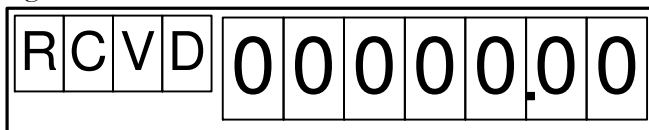

Maximum Demand – The MD registers hold the highest demand value recorded over the configured demand period operating over a specific TOU period. The meter will be able to display four MD registers numbered MD 1 to 4. The MD register will be shown to 2 decimal places.

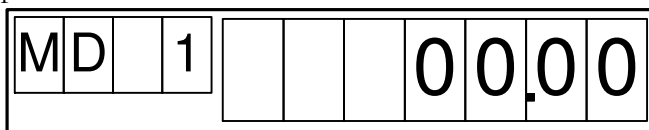

Instantaneous Power – An indication instantaneous of power consumed in kW

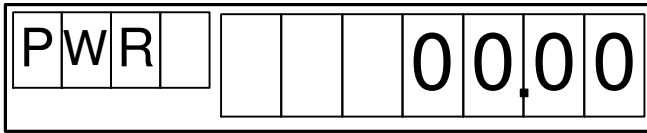

Display test – All segments including all icons to be shown

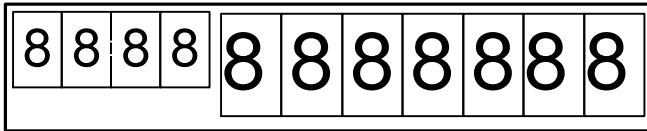

Tariff Plan Indication – The meter will display a 4-character rate plan ID to identify the rate plan configured into the meter. The ID will be sent from the CS to accompany the tariff plan configuration. The ID is displayed in the 4-starburst display characters.

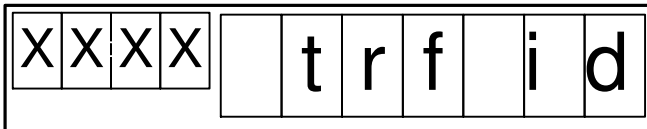

Time and Date Displays

The Time in the meter is shown as:

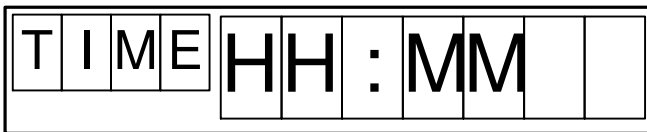

Standard Date format is displayed as:

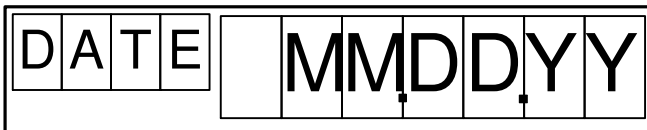

The optional ISO standard format (Canada) is displayed as:



Tamper Displays

Tamper Count Display shows- number of time meter has detected a tamper attempt

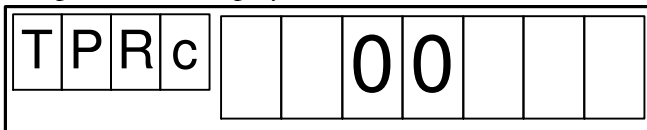

Tamper Time Display shows– last time the meter detected a tamper attempt

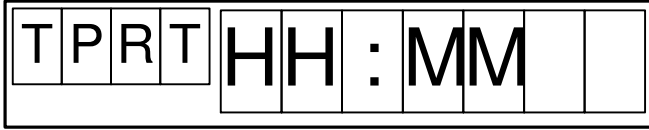

Tamper Date Display shows – Last date the meter detected a tamper attempt. This will change to YY.MM.DD if display is configured to ISO (Canada) standard format.



Prepay Displays

The Credit level Display shows – remaining credit

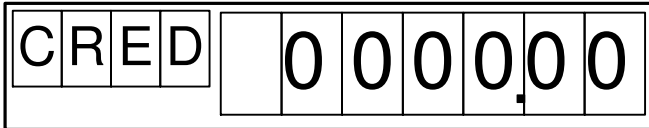

Last Payment value Display shows – Value of last payment made to meter

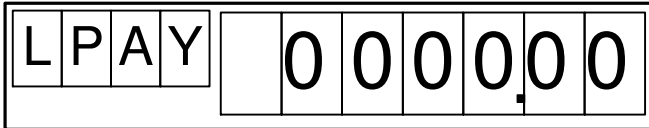

Last credit date Display shows - Last date when a value of credit was transferred
 If configured to ISO Standard Format (Canada) the date will be displayed as YY.MM.DD



Credit transaction identifier Display shows – ID of last top-up transaction

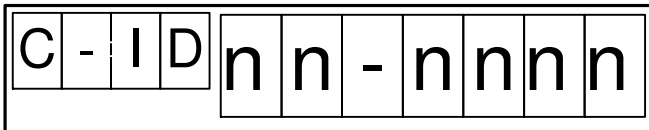

Warning and Engineering Displays

Low Voltage Warning Display shows – Warning message shown if supply voltage is below preset voltage limit.

L	O	W	U	O	L	t	A	G	E
---	---	---	---	---	---	---	---	---	---

Power Fail message Display shows – Mains supply has failed.

P	W	R	F	A	I	L
---	---	---	---	---	---	---

PLC Node Display shows - Address used to identify data packets sent by the Payment Unit

N	O	D	E	0	0	0	0	0	0
---	---	---	---	---	---	---	---	---	---

Program Download Active

P	R	O	G	A	C	T	I	V	E
---	---	---	---	---	---	---	---	---	---

Verifying downloaded program

P	R	O	G	V	E	r
---	---	---	---	---	---	---

Error detected in downloaded program

P	R	O	G	E	r	r	o	r
---	---	---	---	---	---	---	---	---

Reprogramming the flash-EEPROM

P	R	O	G	F	L	A	S	H
---	---	---	---	---	---	---	---	---

Verifying reprogrammed flash-EPROM

P	R	O	G	V		F	L	A	S	H
---	---	---	---	---	--	---	---	---	---	---

Reprogramming completed successfully

P	R	O	G		d	O	n	E		
---	---	---	---	--	---	---	---	---	--	--

Reprogramming failed

P	R	O	G		F	A	I	L		
---	---	---	---	--	---	---	---	---	--	--

 Note: Please note that all energy registers can be configured to show one, two or no decimal places.

Display Cycling

The meter shall be capable of displaying a configurable display sequence. The display sequence can be made up from any of the available meter displays (except engineering displays for Ampy use) in any order.

The display sequence is advanced automatically with the time delay between advances configurable between 1 and 60 seconds. Display end is not to be shown at the end of the sequence.

Extended Display

Any of the above displays can be configured into the extended display usually to provide extra information that may be useful for a field technician during diagnostic activities. For example, diagnostic displays relating to PLC information would normally only be viewed through the extended display facility.

The extended display is activated through an operation provided by the AMPY Field Unit Software. The extended display activates for 60 seconds, and then the meter will revert back to the normal display cycle. Each display will scroll at the configured display scroll rate. Display scroll rate is configured through the Central System.

LCD Bottom-Number Indications used by PLC Communications

The table below shows the flashing numbers that may be displayed in the meter (possible permutations) that may be viewed and their description.

Condition	Indication				Explanation
Config Fail	1	2	3	4	PLC hardware failing to configure correctly
Ping Response			3	4	Valid response received to “ping” test packet just sent
Valid Packet			3		Good (enhanced) packet received from associated CIUnit (on own address)
Valid Packet		2	3		Good (old format) packet received from associated CIUnit (on own address)
Wrong Addr		2			Packet seen for other destination address on wire; other normal traffic
Time Out	1				All of packet did not arrive within expected interval; could be due to a noise burst or to poor signal level
Corrupt Packet	1	2			Complete packet received for own address but corrupted by noise or collision on wire (bad frame check)
Bad Packet	1			4	Complete packet received for own address but containing inconsistent control information (CIUnit problem?)
Duplicate Addr		2		4	Another meter has the same PLC address and customer number
Internal Error	1	2		4	Possible software error detected in meter

Indication “5” (steady) — radio out-station in relay mode

Indication “5” (alternating) — IR optical interface signed-on

LCD Icon Indicators

The table below shows details for the Power Registration Icon Indicators that may be displayed in the meter (possible permutations) that may be viewed and their description.

Power Registration Icon indicators	
Action	Description
Indication BLOCK	Contactors closed (blink-off every 1Wh)
Indication RIGHT-ARROW	Importing energy (forward power)
Indication LEFT-ARROW	Exporting energy (reverse power)
Indication LA—BLK—RA (alternating)	Contactors drive failure, “safe-mode”

The table below shows details for the Radio Reception Icon Indicators that may be displayed in the meter (possible permutations) that may be viewed and their description.

Radio Reception Icon Indicators	
Action	Description
Indication RADIO (steady)	Radio out-station attached to a base-station
Indication RADIO (blink-off)	Radio interface activity
Indication RADIO (alternating)	Radio out-station unlocked or hunting

The table below shows details for the PLC Icon Indicators that may be displayed in the meter (possible permutations) that may be viewed and their description.

PLC Icon Indicators	
Action	Description
Indication PLC (steady)	PLC interface configured & enabled
Indication PLC (blink-off)	PLC interface activity
Indication PLC (alternating)	Trying to configure PLC interface

The table below shows details for the Tamper, emergency and Pre-Payment Icon Indicators that may be displayed in the meter (possible permutations) that may be viewed and their description.

T E and P Icon indicators	
Action	Description
Indication SQUARE-T	Tamper detected
Indication SQUARE-E (steady)	Emergency connection active
Indication SQUARE-E (alternating)	Wake-up connection active
Indication SQUARE-P	Prepay mode active
Indication T→E→P (repeating)	Metrology test mode active

C O N T E N T S

- Time of use
Rate Switching
and Power
bands
 - Tariff Rate Plan
Demand
Response
Indicator
 - Block Tariff
Power Switch
Threshold
Values
 - Tariff Plan
 - Demand
Response
Indication
Assignment
-

Rates and Tariffs

Rates and Tariffs applicable to the meter

Time of use Rate Switching and Power Band Tariffs

Time of use kWh rate recording operates according to a time switching matrix. The energy recorded at a particular rate may be charged at a fixed price throughout the effective time of the tariff or at a variable price according to the amount of power consumed.

TIME SWITCHING

The meter is capable of holding a total of 15 time switches. Each time switch consists of:

1. Switch start time in hours and minutes
2. Rate number the meter is to switch to (1 to 4)
3. Day of the week in which the switch should operate (Mon - Sun)

Time Switch	Start Time	Rate	Enabled switching days						
			Mon	Tue	Wed	Thru	Fri	Sat	Sun
1	HH:MM								
2	:								
3	:								
4	:								
5	:								
6	:								
7	:								
8	:								
9	:								
10	:								
11	:								
12	:								
13	:								
14	:								
15	:								

The meter uses the RTC time (with any DST alterations) to switch between the configured TOU rates. A configured time switch will only operate on the configured days of the week. On reaching the start time of the a time switch the meter will show the defined rate as the active rate and record and consumed energy into the appropriate rate register

The meter will hold a second set of future time switches as described as above. The second set of switches will be assigned a future activation date, upon reaching this date the meter will overwrite the active switches with the second set. This will allow seasonal rate switching in the meter.

Example: If a three rate tariff was required with rate 1 active 00:00 to 07:00 and rate2 active for the rest of the day on weekdays with rate 3 active on weekend, as shown below:



To operate this tariff the following time switches would be required in the rate-switching plan:

Time Switch	Start Time	Rate	Enabled switching days						
			Mon	Tue	Wed	Thru	Fri	Sat	Sun
1	00:00	1	✓	✓	✓	✓	✓		
2	07:00	2	✓	✓	✓	✓	✓		
3	00:00	3						✓	✓

Tariff Rate Plan/ Demand Response Indication Assignment

Billing Period

The meter can calculate several features over a configurable billing period. The billing period consists of a configured start date and duration specified as either a number of days or calendar months.

The Billing Period duration is defined in the range of: 1 to 115 days; or 1-12 calendar months.

The Billing Period has a start date defined as DDMM. The day range is between 1st and 28th day. The month range is 1-12, January to December. No year is applied.

The Billing Period end date is calculated as the start date plus the number of days or calendar months of the Billing Period. Where a monthly period is applied the meter will use the day specified in the start date as the start day of the next period following the specified number of month's duration. The Billing Period ends at 24:00 on the Billing Period end date. At the end of a Billing Period the next Billing Period shall start automatically.

Features using the Billing Period for calculation and logging of data include:

- Block Tariff (start day)
- Data logging
- Monthly reads

Example 1

If a billing period were specified as 1 calendar month in duration starting on the 5th June the billing period would operate as follows:

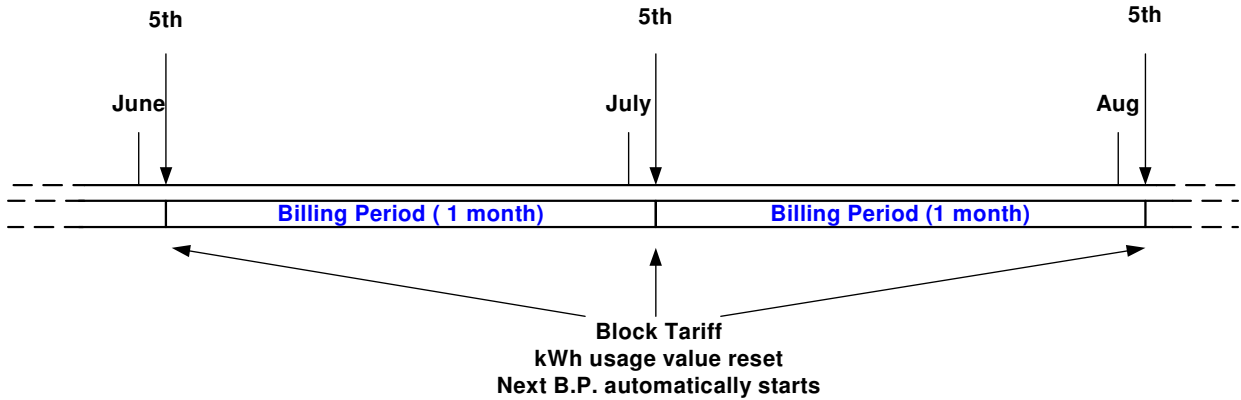

On the 5th of each month the Block tariff's billing period usage value is reset. As a result the block tariff resets and uses block 1 price until the first power switch threshold is reached.

Example 2

If a billing period is specified as 28-day duration starting on the 5th June the billing period would operate as follows:

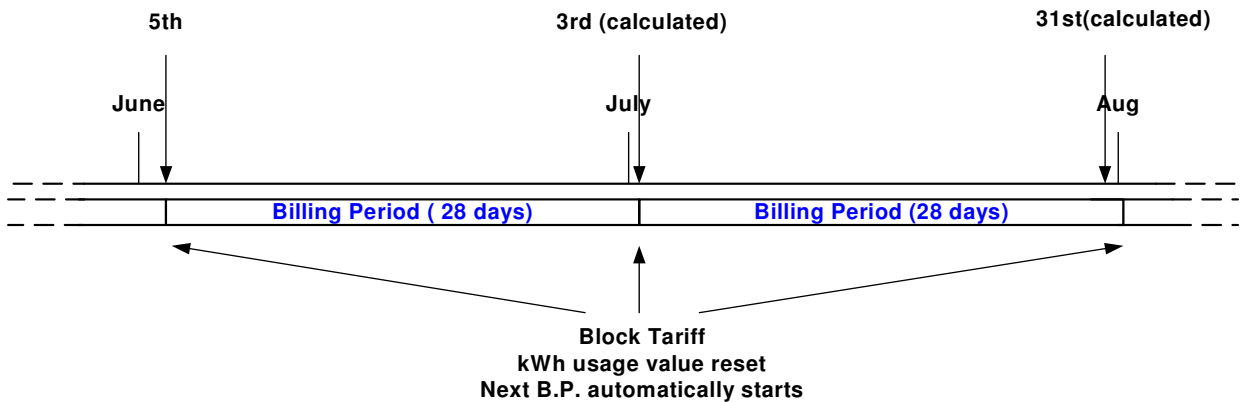

The billing period is calculated 28 days from the start date. After each 28-day period the Block tariff's billing period usage value is reset. As a result the block tariff resets and uses block 1 price until the first power switch threshold is reached.

Block Tariff Power Switch Threshold Values

The meter is capable of operating a Block tariff where the price of electricity is changed according to the usage from the start of the Billing Period.

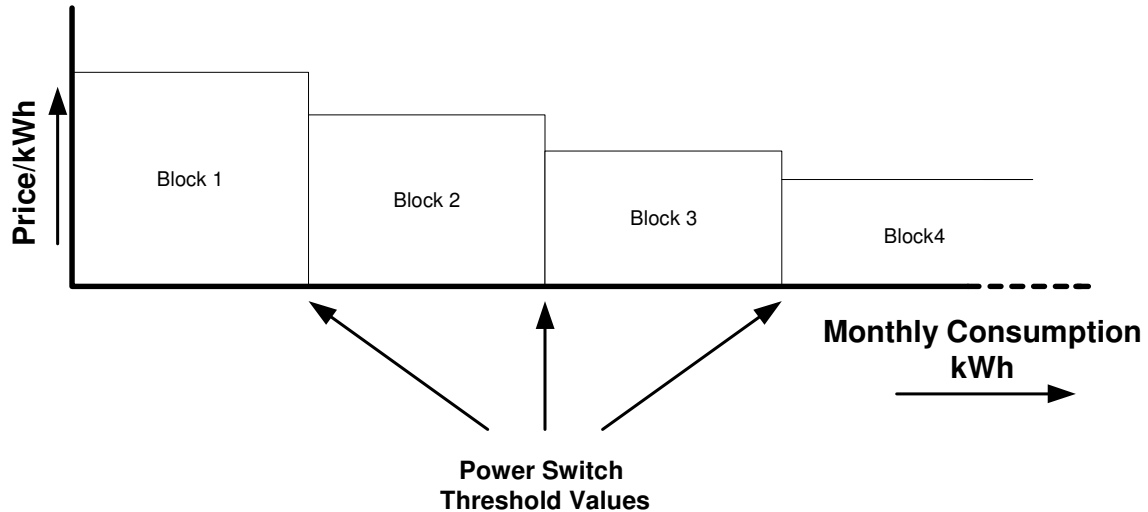

The meter has the ability to hold three Power switch threshold values; these values represent the value in kWh between blocks. The block tariff begins at the start of a billing period. The meter stores \$/kWh tariff values for each block shown above (see tariff matrix).

From the start of a billing period the total number of kWh's or kWh's consumed at current TOU rate, are recorded. When the recorded value reaches a threshold value, the \$/KWH tariff will be changed according to the price defined for the next block.

Block four has no limit. When reaching block four the meter will continue to charge at the block four rate until a new billing period is reached. If a threshold value is not entered then the previous block will remain operative.

Tariff Plan

The rate at which the meter will charge can be automatically changed according to the amount of power consumed over a fixed period. When using the power step tariff a set of \$ per kWh prices are entered against consumption bands, the price altering once the power consumed reached that kWh threshold value. The tariff prices applied by the meter can be compiled from: TOU tariff, Block tariff or a combination of both

The tariff will consist of a matrix of up to 16 prices as shown diagrammatically:

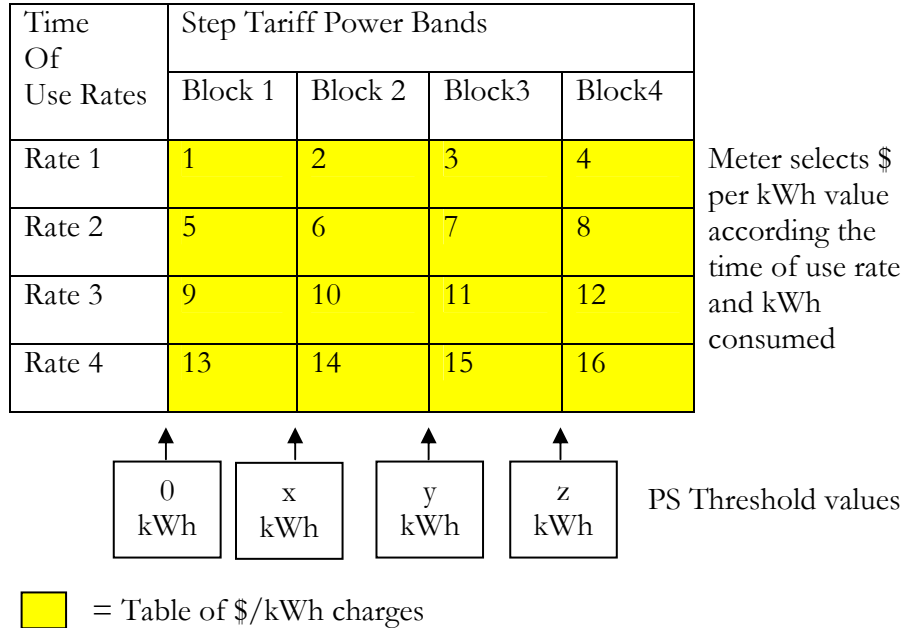

The \$/kWh price has the range of 0-9999.99999

Block Tariff - Example

If a block tariff is configured, the meter will charge according to the usage during the month. Initially the meter will charge the Block 1 \$/kWh rate until the threshold x kWh's is reached. Upon reaching this threshold, the Block 2 \$/kWh rate is applied and so on. A block tariff will use prices 1, 2, 3 and 4 only.

Example - TOU Tariff

When operating a TOU tariff, the meter will adjust pricing according to the Time Switching scheme set into the meter. If the meter is configured to switch to Rate 1 the meter will charge for energy at price set against Rate1 in the matrix. A TOU only tariff will use prices 1, 5, 9 and 13 only

Combination tariff - Example

A Block and TOU tariff may be combined. As the meter switches rates according to the Time switching plan the \$/kWh charge dynamically changes according the Block tariff the meter has switched to. A combination tariff can use any of the 16 pricing slots.

Demand Response tariffs will operate as TOU only. A Demand Response command will dynamically change the rate switching with energy recording and pricing switched to a particular rate. A combination tariff could not be reconciled.

Demand Response Indication Assignment

In order to operate the DR indicators on the CIU a particular rate will be assigned a DR indicator type in the Tariff Plan.

Enable DR Indicator			Time Of Use Rates	Step Tariff Power Bands			
Green	Amber	Red		Block 1	Block 2	Block3	Block4
			Rate 1	1	2	3	4
✓			Rate 2	5	6	7	8
	✓		Rate 3	9	10	11	12
		✓	Rate 4	13	14	15	16

When the meter is switched to a particular rate the Enabled Demand Response indicator will be lit on the CIU. This will operate whether the meter is in a normal Time switching plan or whether the rate has dynamically changed according to a Demand Response command.

Example

Rate 1 is not configured, Rate 2 is assigned Green, Rate 3 Amber, and Rate 4 is assigned Red.

C O N T E N T S

- Daylight Saving
 - Meter Test
Mode
 - Special
Contactor
Operation
 - Fixed Charges
 - Accountancy
Configuration
 - Credit
Transactions
 - Credit
Information
Log
 - Data logging
 - Emergency
Time Log
 - Self
Disconnects
Logging
 - Decommission
Data
 - Date / Time
 - Holidays
-

Meter Operation

Operational functionality for the 5252 Meter

Real Time Clock

The meter is fitted with a real time clock. The clock remains accurate by receiving time and date updates by the Central System.

During periods of power failure an internal battery maintains the time and date. In battery backed mode the accuracy is maintained to within \pm {tba} minutes per year (at nominal temperature)

The time display is shown in 24-hour mode. In standard operation the date is shown as MMDDYY. Optionally the date may be displayed in an ISO standard format YYYY-MM-DD (Canada)

The calendar used in the meter operates a standard Gregorian calendar and automatically corrects for leap years.

The clock is configurable to operate all year without DST alteration or to switch automatically for DST during the summer months.

Daylight Saving

Daylight saving is a programmable option. If enabled, the start and end values are programmed: Month, Week (1, 2, 3, 4 or last), day, activation time (hours/minutes). The time adjustment can be configured e.g. +/- 1hour.

When day light saving is activated the current maximum demand will be reset. The profile log will indicate daylight saving by an indicator placed against the data.

Examples of setting day light saving

Month = 4: Week = 1: Day = Thursday activates on the 1st Thursday in April

Month = 4: Week = 2: Day = Friday activates on the 2nd Friday in April

Prepayment operation general

General prepayment operation is the same as the present 5211-meter with exception that credit is transferred from the Central System rather than from the present smart card. When credit is transferred to the meter which takes it out of debt and into credit, the contactor will not close until the meter receives a wake up message from the CIU. For safety, this assumes the customer is home. A \$/kWh charge will be deducted each time a kWh is recorded in the active rate register.

Holidays

The meter can be programmed with up to 15 configurable Holiday Dates for the purpose of 'friendly no disconnect periods' and for the support of holiday kWh charges.

The tariff that the Holiday Dates will operate in can be defined from the available rate tariffs 1 -4 if configured. If only one tariff exists then the Holiday Dates are set to operate using the default tariff. As the holiday dates may vary from year to year, the utility will have to update the dates via the AMS / smart card.

Seasonal Non Disconnect

Seasonal Non Disconnect will operate between a configurable start and end date/time. The period of time between the dates means the meter will not disconnect even if credit has expired. The time configuration ensures the meter connects/disconnects at a friendly time.

If the meter was disconnected before the start date the meter will remain disconnected.

If prepaid energy reaches zero during the no-disconnect period the credit register will continue to record energy usage as a debt. If the meter’s credit balance is negative at the end date/time the meter will automatically disconnect.

Friendly Non-disconnect

The meter offers a facility to prevent disconnection of the contactor when prepaid credit falls below zero. Each day type (Mon to Sun) will be programmed with a start and end time for the friendly zone. Friendly zones may differ on each day.

If prepaid credit reaches zero during a friendly period the contactor will open when the end time of the zone is reached

The ‘friendly’ periods can be set either by the factory or configured by the Field Unit Software or via the AMPY Management System /Central System

Possible configuration options for Friendly Non-Disconnect Settings

Weekday	Start Time	End Time	Friendly All Day	Not Configured
Monday	HH:MM	HH:MM		
Tuesday	HH:MM	HH:MM		
Wednesday	HH:MM	HH:MM		
Thursday	HH:MM	HH:MM		
Friday	HH:MM	HH:MM		
Saturday	HH:MM	HH:MM		
Sunday	HH:MM	HH:MM		

Tariff Storage

The meter stores two sets of tariff data active and future. The future tariff (if available) will come into force on its activation date (see data logging).

Fixed Charges

The meter can store two sets of fixed charges data for active and future. The future charge will come into force on its activation date. Future dates may be used to implement summer and winter seasons.

Fixed Charges are collected every 1/100th of a week. This ensures the maximum amount the credit register decrements in reasonably sized amounts. The meter has 2 registers that can be set independently to recovery fixed charges.

Fixed charges can be configured to collect charges whilst the meter is disconnected.

Configuration example:

Field Name	Type	Active Date
SC1 Fixed Fee Total	Active	None
SC1 Fixed Fee Total	Future	June 30 2002
SC2 Budget Billing	Active	None
SC2 Budget Billing	Future	June 15 2002

The Fixed Charges registers have a range 0000.00 – \$9999.999

Accountancy Configuration

The maximum credit value will be \$9999.99 and minimum \$0.01

The maximum kWh rate will be \$9999.99999 and minimum \$0.00000

Credit Transactions

The meter will hold the last 100 credit transaction ID's in a rolling buffer, the last 5 credit transaction ID's are always returned on the smart card. The Management System knows the credit transaction IDs assigned to each card.

Credit Information Log

The meter will hold a rolling record of last 16 transactions that been seen in the meter, and will store information for the credit value, credit Id, Status and time stamp for each record. An entry pointer flag denotes the last recorded transaction.

Demand Response

The meter is able to offer variable pricing to the customer using the TOU rates, which can be switched outside of the preset rate plan by a command from the Central System.

The meter will respond by overriding the normal rate-switching plan and switching to a defined rate between a start and end time and date.

The Demand Response command is defined as:

	Date	Time
Start	MM.DD.YY	HH:MM
End	MM.DD.YY	HH:MM
Switch to Rate	1 to 4	

The meter has the ability to store 2 demand response commands as described above.

Upon reaching the start time of the command the meter will switch to the defined rate and record any energy consumed after the start date into the defined rate register.

Upon reaching the end time of the command the meter will revert back to the normal rate-switching plan

While the meter is in a Demand Response period, prepay customers will be charged at the defined \$/kWh rate. The CIU will reflect the change in rate and tariff by updating 'Rate x charge is \$x.xx' display to the defined \$/kWh rate.

Example:

The following scenario shows the rate switching of the meter when a Demand Response command is received. The example shows the start of the January 2006 for 4 days.

The meter is configured to run a TOU Rate switching plan as follows:

Time Switch	Start Time	Rate	Enabled switching days						
			Mon	Tue	Wed	Thru	Fri	Sat	Sun
1	00:00	1	✓	✓	✓	✓	✓	✓	✓
2	07:00	2	✓	✓	✓	✓	✓	✓	✓

A Demand Response command is sent to the meter with the following parameters –

	Date	Time
Start	01.02.06	12:00
End	01.02.06	18:00
Switch to Rate	4	

The Demand Response command would have the rate switching effect on the meter:

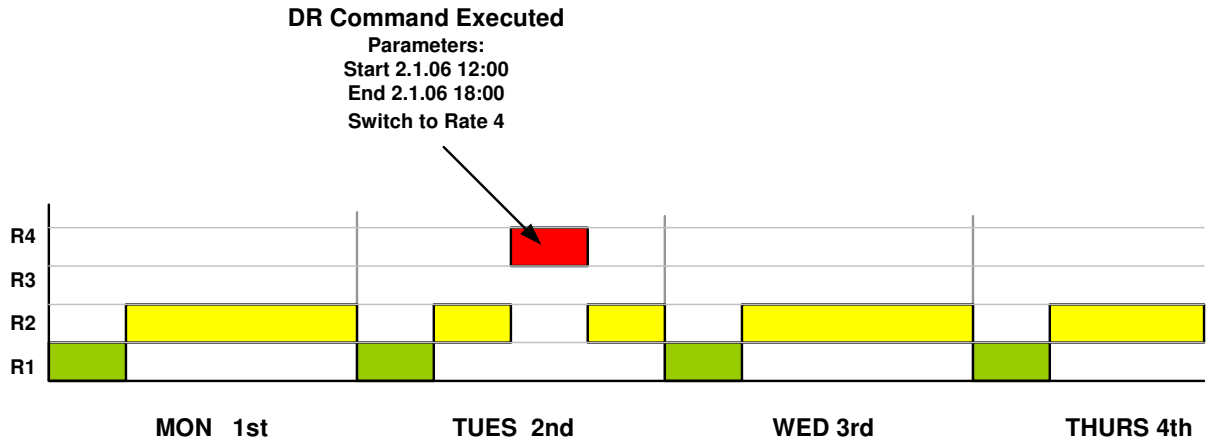

On Tuesday 2nd the normal rate switching plan would be suspended. The Demand Response command would override the normal TOU plan. Any energy consumed between 12:00 and 18:00 would be recorded in the R4 register. Prepay customers will be charged at the appropriate \$/kWh rate with the CIU showing the \$/kWh rate. The CIU will indicate Demand Response LED's according to TOU rate applied.

Remote Disconnect/Reconnect

When operating in credit mode the meter may be issued a command via the Central System to open the meters contactor. Upon receipt of such command the contactor will open and remain open, the metrology indicator on the display will not be shown. The command may be accompanied by an ad-hoc read request in the case of changes in tenancy.

Reconnection of supply will be made following a command from the Central System. A 'System Initiated Closure' command will close the contactor upon receipt of the request without any further customer action. This assumes the utility knows the customer is present at the installation or that the installation is safe for reconnection.

In some cases reconnection of supply will be offered to the customer following a command from the Central System. A 'Customer Initiated Closure' command will offer the customer the ability to close the contactor using the CIU unit. In this case, when a wake up message is sent from the CIU the meter will use this as a signal to restore supply. This mode will allow the utility to send a reconnect command without knowing whether the customer is present; the customer effectively reconnects his own supply. Following a 'Customer Initiated Closure' command the CIU will be instructed to display a supply-reconnected message

Safety Reconnection

The meter will ensure that the customer does not have a secondary supply connected (own generator etc.) when reconnecting supply.

The meter is fitted with a detection circuit connected across the customer load side of the contactor to check for voltage present at the time of switch closure.

If the meter receives either a 'system' or 'customer initiated' closure the meter will check the voltage on the customer supply side of the open contactor, prior to closure. If voltage is not considered present the meter will close the contactor (provided customer has chosen to close contactor in case of customer initiated closure).

If the detection circuit detects the presence of external supply voltage the contactor will not close and the closure command will be returned with an error.

Meter Test Mode (Metrology Testing)

The meter can be programmed into a test mode to allow accuracy tests to be performed. All accountancy will be frozen and a separate test mode register used to accumulate power throughout the test.

The test mode register will always be zero when switched into test mode. When the meter is disconnected and re-powered or reprogrammed out of test mode the accountancy will restart.

Field Test Mode

This operation can also be used in the field using an option called Field Test Mode. This allows a field operative to remove a customer meter from the wall, perform a metrology test, and then replace it back on the wall. The Meter will revert to normal operation after two Power-ups or after a 60 minutes safety period (the contactor will revert back to its original state prior to the operation).

Profiling

The meter will record a profile of 15-minute interval kWh readings. Hourly or half hourly profiles are obtained by summation of profiles in the Central System. Up to 50 days of the most recent profiles will be stored within the meter, if the profiles are not down loaded within 50 days the oldest reading will be over written with the most recent. Each profile consists of the advance Wh's since the previous 15 minutes profile.

During power fail the missing kWh readings will be padded to maintain a sequential log. If the meter is disconnected for more than three days, the whole log will be cleared. When day light saving is activated the profile log will indicate daylight saving by an indicator placed against the data.

Maximum Demand

Active power is integrated over a configurable period of 1,2,3,4,5,6,10,12,15,20,30 or 60 minutes. The maximum demand value is calculated at the end of each period, the highest demand value is stored complete with time stamp information.

Demand periods will be synchronized to the hour. For example, if the interval is 15 minutes, the starting times are 10:00, 10:15, 10:30 etc.

The meter will record maximum demand values into one of 4 MD registers (MD1 to 4). Each MD register will be active according to the configured TOU rates i.e. if TOU rate 2 is active MD 2 register will be active.

At the end of each day (00:00) the meter will record the four MD registers into a rolling log. The rolling log will contain the last 3 days of MD recordings. On storage of a new set of recordings the earliest set will be pushed out. At the same time the meter will reset the running MD registers 1-4.

Energy Registration

An infrared LED is mounted on the front of the meter, pulsing at a rate proportional to the measured load. The pulse value is identified on the meters fascia. The pulse can be used for checking the meter calibration and will illuminate continually to indicate no load (Anti Creep), with further information presented on the cycling display.

Tamper Detection

The meter is fitted with a tilt detection switch to detect removal of the meter from its base. Any triggering of the tamper switch is reported via status collection from the meter.

Visually the tamper flag will be shown on the display.

Optionally the meter may be configured to open the main contactor.

Resetting of the tamper flag/supply reconnection can be achieved by system command or using the meter optical port.

Optionally the tamper detection feature can be disabled

Power Outage Reporting

The meter holds a rolling log containing the last 5 reported outages. Each log entry will consist of a time and date stamp of the outage plus the reconnection time and date stamp.

The log will be held as follows:

Occurrence	Supply ON Date /Time	Supply OFF Date/Time
1		
2		
3		
4		
5		

Special Contactor Operation

A mode is available to test the meter in environments where there is insufficient supply to fire the contactor. This mode can be used to test meters using RFL5800 and UTEC 620 test machines.

The meter can be configured not to reaffirm the contactor position during testing by special command.

The meter will revert back to its previous state after two power ups or after one hour has elapsed.

A pre-condition with this operation is that the contactor is already closed.

 **Note:** Once the contactor has been changed the meter will not attempt to operate the contactor for 60 seconds following the power-up. Whilst in this mode the contactor will not be periodically reinforced.

Data Logging

At the end of each month and on the tariff activation date the meter will store the 4 kWh rate registers, tariff identifier and date. The meter will store a rolling 6 months of kWh usage data for the 4 kWh rates in a rolling buffer. The oldest month's data will be overwritten with the most recent month's data. The tariff update registers will be overwritten on the next tariff update.

 **NOTE:** The average daily kWh for any month can be calculated by dividing the monthly consumption by the number of days in the month (performed by the AMPY Management System).

Each credit transaction is logged for accounting purposes.

Emergency Time Log

The meter will hold the last five values for when an emergency code has been received by the meter. The meter will store whether the emergency code entered was either a 24 hour E-Code or a 7 day E-code. An entry pointer flag denotes the last recorded emergency time.

To calculate the number of days recorded in the log number of minutes should be divided by the number of minutes in a day (1440) and roundup the value to the nearest day.

NOTE: This will allow the FUS to enter an e-code other than 1 and 7 days

The log will record the following details depending on the minutes entered:

Emergency Minutes	Record In Log (days)
1440	1
4320	3
10080	7

Self Disconnects Logging

The meter will hold the last five disconnect and reconnection date pairs. The disconnect time and date will be recorded when the contactors opens. The reconnection time and date will be recorded when the contactor closes.

Example

Log Entry	Disconnect Date	Reconnect Date	Description
1	1-1-2006 10:34:34	20-1-2006 09:00:02	Complete entry
2	28-2-2006 03:23:23	1-1-1970 00:00:00	Part entry: No reconnect date
.....	1-1-1970 00:00:00	1-1-1970 00:00:00	No date logged
5	1-1-1970 00:00:00	1-1-1970 00:00:00	No date logged

Decommission / Re-commission Data

The meter is able to cope with changes in tenancy to the installed property by a Decommission Command.

A decommission command can be configured in advance; the Central System will accompany a decommission command with an activation date and time for when the process should occur. The meter will only perform the operation at the configured date and time.

A decommission command will have the following configurable parameters, including:

- Reset or overwrite Credit register, configurable from 0 to maximum top-up value (if in prepay mode)
- Clear credit transaction log
- Option to open meters contactor

The decommission command will trigger a Snapshot of readings. Registers to be read and sent to the CS will include:

- All kWh registers
- Maximum Demand registers
- Value of Credit register prior to Decommission (if in prepay mode)
- Snapshot will be time and date stamped

Re-commissioning will follow a Decommission. The Central System will send any new tariff settings including new tariff plans, TOU switch settings and a Contactor closure command (If required). At Re-commission the meter will also be sent a new Credit Register value (if not set by the decommission command). All re-commission commands will have an activation date.

CONTENTS

- Credit/debit Register
 - Maximum Credit Register
 - Accountancy Configuration
 - Decimal Point Configuration
 - Maximum Demand period
 - Active Register
 - kWh Register
 - \$ Per Unit for Rates 1 – 4
 - Usage yesterday
 - \$ Usage Per Hour
 - KW Usage Per Hour
 - \$Usage Today/Month/Last Mont
 - Active Fixed Charge 1 and 2
 - Future Fixed Charge 1 and 2/Activation Date
 - Seasonal non Disconnect Start and End Date/Time
 - Operation Mode
 - Power Fail Count
 - Wake up Register
 - Credit Transfer Register
 - Credit History
 - Credit Information Log
 - Friendly Debt Register
 - Energy registration Modes
 - Voltage Reporting
-

Chapter**5**

Meter Registers

Meter Registers for the 5252 Meter

Credit/Debt Register

The Credit/Debt register is settable in the range \$-9999.99 to +\$9999.99. All electricity consumptions are collected from this register as well as ancillary charges such as fixed charges and debt collection. At reaching the maximum credit, configurable via smart card, card will not be accepted.

This register can be reset to zero using the AMPY Field Unit Software.

Maximum Credit Register

The maximum credit register is settable in the range \$-9999.99 to +\$9999.99.

Accountancy Configuration

The maximum credit value for the meter is \$9999.99 with a minimum value of \$0.01

The maximum kWh rate for the meter is \$9999.99999 with a minimum value of \$0.00000

Decimal Point Configuration

The decimal point configuration is applicable to the following registers:

Total kWh

Rx Registers (x= rate 1 to 4)

Configurable options 0, 1 or 2dp.

Maximum Demand Period

This registers configures the sampling period for logging the maximum demand.

Configurable options 1,2,3,4,5,6,10,12,15,20,30 or 60 minutes.

Active Rate

This register indicates the current active chargeable rate for kWh units.

kWh Registers

The Total kWh register and kWh registers for time of use rates 1 to 4 can be read. Each register has a field size of 00000.01 to 9999999.99 kWh.

The four kWh rate registers and total kWh register can be reset to zero using the AMPY Field Unit software.

\$ Per Unit for Rates 1 TO 4

The rate per kWh unit for each of the four TOU rates, are settable in the range of \$0.00000 to \$9999.99999.

Usage Yesterday

The usage yesterday stores the previous days consumption in \$ values. This is calculated on all charges normally applied within a 24 hour period and is settable in the range \$0.01 to \$9999.99.

\$ Usage per Hour

The usage register stores information, in real time, on consumption in \$ values. This is calculated on all charges normally applied within the last hour and is displayed from \$0.01 to \$9999.99. The register is calculated on a three second average.

KW Usage per Hour

The kW usage per hour register stores information, in real time, on the consumption in kW per hour. The register is calculated on a three second average.

\$ Usage Today

This register stores the actual \$ cost for the current day and includes all normal charges. The register is updated whenever the main credit register is adjusted and is displayed from \$0.01 to \$9999.99

\$ Usage This Month

This register stores the actual \$ cost for the current month and includes all normal charges. The register is updated whenever the main credit register is adjusted and is displayed from \$0.01 to \$9999.99.

\$ Usage Last Month

This register stores the actual \$ cost for the previous month and is displayed from \$0.01 to \$9999.99.

Active Fixed Charge 1 and 2

The two registers store the active values for the charge 1 and 2. Charges are collected every 1/100th of a week. The registers have a range 0000.00 – \$9999.999.

Future Fixed Charge 1 and 2

The two registers store the future values for the charge 1 and 2. The registers have a range 0000.00 – \$9999.999.

Future Fixed Charge 1 and 2 Activation Dates

The two registers store the dates in seconds from 1/1/1970 that the future fixed charges will be applied to active fixed charges registers.

Seasonal Non Disconnect Start and End Date/Time

The two registers stores the date and time the meter will not disconnect/disconnect.

Operation Mode

The operation mode stores the meter configuration. The meter has two operation modes, pre-payment or credit.

Power Fail Count

This register stores the total number of power fails occurrences. The register has a range of 0 to 255.

Wake Up Register

This register stores the number of wake up messages sent to the meter, details are recorded in a rolling record for 10 entries and a counter will register up to '255 wake up' attempts. This information can be retrieved using the AMPY Field Unit Software.

Credit Transfer Register

This register contains details for the last 10 transactions that have been seen by the meter, detailing time and date record, credit value /ID, and status.

Credit History

The meter holds the last 100 and the last 5 credit transactions in a rolling buffer. The log records the Credit ID information

Credit Information (Transfer) Log

The meter holds a rolling record of last 16 transactions that been seen in the meter, and logs the following information for the credit value: Date/Time, Credit ID, Value and Status
An entry pointer flag denotes the last recorded transaction.

Friendly Debt Register

The friendly debt register ensures that wake up messages can not be used to invoke a configured friendly period when the accumulated debt in the meter is greater than the friendly debt level.

This principle is also used when a credit amount is added which is not greater than the limit set in the friendly debt register, or if a wake up is invoked using both buttons of the Customer Information Unit. This information can be retrieved using the AMPY Field Unit Software.

 **NOTE:** If the friendly debt register is greater than the accumulated debt in the meter, and an E-Code is successfully accepted by the meter, then the contactor will remain closed during the entered emergency period.

Possible scenario explanations:

Example 1

Friendly Debt Value is configured to \$- 5.00

Customer balance (accumulated debt) \$- 3.00

Customer presses both buttons on the CIU within 10 minutes of a friendly period start time, or during a friendly period. The meter will remain connected for the duration of the friendly period.

Example 2

Friendly Debt Value is configured to \$- 5.00

Customer balance (accumulated debt) \$- 6.00

Customer presses both buttons on the CIU within 10 minutes of a friendly period start time, or during a friendly period. The customer can have up to 5 wake up attempts per day, but after the 10 minute period the meter will disconnect. The meter will not connect for the duration of the friendly period.

Energy Registration Modes

The meter has the ability to register energy in one of three different modes, Cumulative, Detent or Net. In addition the meter will record all Received energy into a separate register. When configured to operate in one of the modes listed, the meter will accumulate energy into the Active Rate and Total Registers (Delivered energy registers) as follows:

Cumulative (Sum) kWh

When operating in Cumulative mode, any Received energy (Export/Reverse energy) recorded by the meter is added to the Active Rate register and ultimately to the Total Energy Register. In this mode, should the meter be removed and refitted upside down, the utility is protected against energy theft.

Example

If 5 kWh were recorded forward (Delivered) through the meter then 2 kWh reverse (Received) through the meter the energy registers would read:

Active Rate Register	7 kWh
Reverse (Received) register	2 kWh

Detent (Delivered) kWh

In Detent mode, Received energy recorded by the meter has no effect on the Active Rate register of the meter. The meter acts as if it is fitted with a reverse stop.

Example

If 5 kWh were recorded forward (Delivered) through the meter then 2 kWh reverse (Received) through the meter the energy registers would read:

Active Rate Register	5 kWh
Reverse (Received) register	2 kWh

Net kWh

With Net registration, Received energy recorded by the meter is subtracted from the active rate register and ultimately the Total Energy registers.

Example

If 5 kWh were recorded forward (Delivered) through the meter then 2 kWh reverse (Received) through the meter the energy registers would read:

Active Rate Register	3 kWh
----------------------	-------

Reverse (Received) register 2 kWh

Delivered (Export/Reverse) register

Any received energy is separately recorded in the Received Energy register. This register will record the total received energy. The display layout is shown in the display section.

It should be noted that the meter will not operate in Net mode when selected for prepay operation.

Voltage Reporting

The meter measures and records the voltage present at the meter for reporting purposes. The meter records the maximum and minimum voltage measured over a 1-day period. The meter holds a rolling log of the last 3 days max/min voltages. The instantaneous voltage present at the meter is also available by performing an ad hoc enquiry to the meter.

C O N T E N T S

- Periodic Daily Reads
- Periodic Monthly Reads
- Periodic Time Update
- Periodic Load Profile Collection
- Instantaneous Power Outage Reporting
- Instantaneous Read Request
- Instantaneous Disconnect /Reconnect Request
- Instantaneous Prepay Transaction
- Instantaneous Request – Config Update
- Global Broadcast – Demand Response

Communication

Communication Properties for the 5252 Meter

Periodic - Daily Reads

The system will schedule a daily read from the meter.
Each daily read will consist of:

- Rate 1 kWh register
- Rate 2 kWh register
- Rate 3 kWh register
- Rate 4 kWh register
- Prepayment Credit level
- Last 5 Credit ID's received
- Status Information (includes tamper detection).

Daily register and credit level reading will be transmitted as a snap shot taken at 00:00

Periodic - Monthly Reads

A read of additional information is collected once per month. The read is scheduled by the Central System and read from the meter between the 1st through to the 28th of the month

- Maximum Demand registers
- kWh Registers (In cases of monthly reads only or failed daily read)
- Self-Disconnect Log (Date/Time contactor opened/closed not balance <0 and >0)
- Emergency time Log
- Credit Log

The Maximum demand registers sent are those previously stored at the end of the billing period.

Periodic - Time Update

Time is updated by the Central System using a global broadcast

Time held by the meter must be kept accurate and within limits stated in performance requirements

Periodic - Load Profile collection

Load profiles will be collected from the meter by the CS. Collection will be part of a scheduled task. Where Load profiling information is not required then the profile information is not collected by the system.

Each individual profile will be transmitted as the advance in kWh's since the previous profile. The set of profiles will be transmitted in a way that will allow time and date stamping of each individual profile.

Instantaneous - Power Outage reporting

When the meter detects a loss of supply that is of sufficient length to be considered a power outage (see electrical parameters) a message is reported to the CS system before the meter and OS module's stored power is depleted.

The outage message will consist of a the meters serial number and a message identifier {tba}

Instantaneous - Read request

A priority request will be sent by the CS to the meter at any time to return the following:

- Rate 1 kWh register
- Rate 2 kWh register
- Rate 3 kWh register
- Rate 4 kWh register
- Prepayment Credit level
- Last 5 Credit transaction details received { # of ID to be agreed }
- Status Information, including tamper detection

Instantaneous - Disconnect/Reconnect request

When operating in a credit mode a request Disconnect Message sent from the CS will instruct the meter to open its contactor.

Two types of closure commands will determine how the contactor is re-closed:

- A 'System Initiated Closure' command will instruct the meter to close the contactor directly
- A 'Customer Initiated Closure' command will allow the customer to reconnect power using the connected CIU.

Instantaneous – Prepay Transaction

When operating in prepay mode the CS will send a Prepay transaction to top up the credit in the meter. A prepay transaction will comprise of payment value and a transaction identifier.

Instantaneous Request – Config Update

Meter shall be able to be reconfigured by a message sent from the CS. Reconfigurable items shall include

- Current/Future Tariff Rate Plan (including time switches)
- Current/Future Fixed Fees
- Operating mode Credit/Prepay
- Resetting of tamper flags
- Friendly Non-Disconnect Hours
- Seasonal Non-Disconnect
- CIU configuration Data (including Display lists)
- Meter configuration Data (including Display lists, DST etc.)
- Holiday dates

Global Broadcast – Demand Response

To allow variable pricing to the customer the CS will send a global demand response message all meters. The message will consist of a start time and date, end time and date and the rate to which the meter will switch. Although the message is a global broadcast, the message will be acknowledged by the meter so that the CS can ensure all meters have received the broadcast.

Definitions

ANSI	American National Standards Institute
DR	Demand Response
CIU	Customer Information Unit
kWh	Kilo Watt-hours
LCD	Liquid Crystal Display
LED	Light Emitting Diode
CS	Communications System
RTC	Real Time Clock
mS	Milli-second
GMT	Greenwich Mean Time – equals UTC (Universal Time Coordinated)
AMS	Ampy Management System