

For more detailed installation, configuration, programming, file transfer, and operating instructions, refer to the *NI-700 and NI-900 NetLinX Integrated Controllers Instruction Manual*, available on-line at www.amx.com.

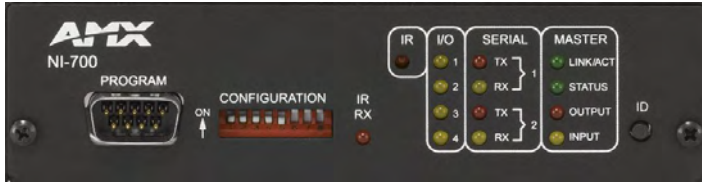

FIG. 1 NI-700 NetLinX Integrated Controller (front view)

Overview

The NI-700 (FG2105-70) is geared to meet the specific control and automation needs of a single room environment, where both price and functionality are the driving requirement. This product is configured to control a limited number of video players, projectors, lighting, thermostats, and other electronic equipment. The NI-700 provides support for one IR/Serial Output port, two RS-232/RS-422/RS-485 ports, four Digital Input/Output ports, and one IR RX port.

ATTENTION!

Verify you are using the latest version of NetLinX Studio (available for download from www.amx.com).

| NI-700 Specifications | |
|--------------------------------|---|
| Dimensions (HWD): | <ul style="list-style-type: none"> 1.58" x 5.54" x 5.12" (4.01 cm x 14.10 cm x 13.00 cm) 1 rack unit high |
| Power Requirement: | <ul style="list-style-type: none"> 280 mA @ 12 VDC Power requirements are usage dependant |
| Memory: | <ul style="list-style-type: none"> 64 MB SDRAM (not upgradeable) 32 MB Flash chip (not upgradeable) 512 Kb of Non-volatile SRAM |
| Microprocessor: | <ul style="list-style-type: none"> 304 MIPS |
| Weight: | <ul style="list-style-type: none"> 1.30 lbs (0.59 kg) |
| Enclosure: | <ul style="list-style-type: none"> Metal with black matte finish |
| Certifications: | <ul style="list-style-type: none"> FCC Part 15 Class B, CE, and IEC 60950 |
| Front Panel Components: | <ul style="list-style-type: none"> Program Port: RS-232 DB9 connector (male) can be connected to a DB9 port on a PC. This port can be used with both Serial and NetLinX commands. Configuration DIP Switch: Sets the communication parameters for the Program port. IR RX LED: Red LED lights when IR data is being received via the rear IR RX port. IR LED: Red LED lights during the transmission of IR or Serial data via the rear IR port. I/O LEDs: Four yellow LEDs light when the rear I/O channels 1 - 4 are active. LED indicator for each I/O port reflects the state of that particular port. Serial LEDs: Two sets of red and yellow LEDs light when the rear DB9 Ports (1 & 2) transmit or receive RS-232, 422, or 485 data. These LEDs do not reflect changes in either the RTS or CTS when hardware handshaking is used. LINK/ACT: Green LED lights when the Ethernet cable is connected and an active link is established. This LED also blinks when receiving Ethernet data packets. Status: Green LED lights when the Controller is programmed and communicating properly. Output: Red LED lights when the Controller transmits data, sets channels On and Off, sends data strings, etc. Input: Yellow LED lights when the Controller receives data from button pushes, strings, commands, channel levels, etc. ID Pushbutton: Sets the NetLinX ID (Device only) assignment for the device. |
| Rear Panel Connectors: | <ul style="list-style-type: none"> RS-232/422/485 (Ports 1 & 2): Two RS-232/422/485 control ports use DB9 (male) connectors with XON/XOFF (transmit On/transmit Off), CTS/RTS (clear to send/ready to send), and 300 - 115,200 baud. IR RX (Port 5): 4-pin 3.5 mm mini-Phoenix port is used to connect one or more (8 maximum) IRX-SM+ swivel mount or IRX-DM+ Decora mount IR receivers. <i>The IR RX port functions using AMX IR codes (38 KHz and 455 KHz) and works ONLY with AMX IR Receivers such as the IRX-DM+ and IRX-SM+.</i> Digital I/O (Port 4): 4-channel binary I/O port for contact closure with each input being capable of voltage sensing. Input format is software selectable with interactive power sensing for IR ports. |

NI-700 Specifications (Cont.)

| | |
|---------------------------------------|---|
| Rear Panel Connectors (Cont.): | <ul style="list-style-type: none"> IR/Serial (Port 3): 4-pin 3.5 mm mini-Phoenix port is capable of supporting high-frequency carriers of up to 1.142 MHz with the output being capable of three electrical formats: IR, Serial, Data. <i>IR ports support data mode (at limited baud rates and wiring distances).</i> AXlink LED: Green LED indicates the state of the AXlink port. AXlink Port: 4-pin 3.5 mm mini-Phoenix (male) connector provides data and power to external control devices. Ethernet Port: RJ-45 port for 10/100 Mbps communication. LEDs show communication activity, connection status, speeds, and mode information: <ul style="list-style-type: none"> SPD (speed) - Yellow LED lights On when the connection speed is 100 Mbps and turns Off when the speed is 10 Mbps. L/A (link/activity) - Green LED lights On when the Ethernet cables are connected and terminated correctly, and blinks when receiving Ethernet data packets. Power Port: 2-pin 3.5 mm mini-Phoenix (male) connector |
| Operating Environment: | <ul style="list-style-type: none"> Operating Temperature: 0° C (32° F) to 50° C (122° F) Operating Humidity: 20% - 85% RH |
| Included Accessories: | <ul style="list-style-type: none"> 2-pin 3.5 mm mini-Phoenix female PWR connector (41-5025) 4-pin 3.5 mm mini-Phoenix female connector (41-5047) 6-pin 3.5 mm mini-Phoenix female I/O connector (41-5063) CC-NIRC IR Emitter |
| Other AMX Equipment: | <ul style="list-style-type: none"> AC-RK Accessory Rack Kit (FG515) CC-NIRC IR cables (FG10-000-11) CC-NSER IR/Serial cables (FG10-007-10) IRX-DM+ IR Sensor (FG458-10 and FG458-11) IRX-SM+ IR Sensor (FG455-01) PMB Pole Mount Bracket (FG531) STS, Serial To Screw Terminal (FG959) Surface Mount Bracket Accessory (FG525) |

Port Assignment and Functionality

NI-700 Port Assignments

| Port | ICSP Port # |
|----------------|-------------|
| Serial Port #1 | 1 |
| Serial Port #2 | 2 |
| IR/Serial Port | 3 |
| I/O Port | 4 |
| IR RX Port | 5 |

Ethernet Ports used by the NI Controller

Ethernet Port Usage

| Port type | Description | Standard Port # |
|------------------------|--|-----------------|
| FTP | The on-board Master has a built-in FTP server. | 21/20 (TCP) |
| SSH | The SSH port functions using the same interface as Telnet but over a secure shell where it uses SSL as a mechanism to configure and diagnose a NetLinX system. Note: SSH version 2 is only supported. | 22 (TCP) |
| Telnet | The NetLinX Telnet server provides a mechanism to configure and diagnose a NetLinX system. | 23 (TCP) |
| HTTP | The Master has a built-in web server that complies with the HTTP 1.0 specification and supports all of the required features of HTTP v1.1. This port is used for unsecure HTTP Internet communication between the web browser's UI and the target Master. | 80 (TCP) |
| HTTPS/SSL | This port is used by a web browser to securely communicate between the web server UI and the target Master. | 443 (TCP) |
| ICSP | Peer-to-peer protocol used for both Master-to-Master and Master-to-device communications. | 1319 (UDP/TCP) |
| Integration! Solutions | This feature on the Master uses, by default, port 10500 for the XML based communication protocol. This port is connected to by the client web browser's JVM when integration! Solutions control pages are retrieved from the on-board Master's web server. | 10500 (TCP) |

Note: While the NI-700 is capable of receiving 8 and 9 bit characters, it cannot receive 7 bit, 1 stop bit data from a serial device (ex: 9600,N,7,1).

Connections and Wiring

FIG. 2 shows the layout of the connectors and components located on the rear of the NI-700 NetLinX Integrated Controller.

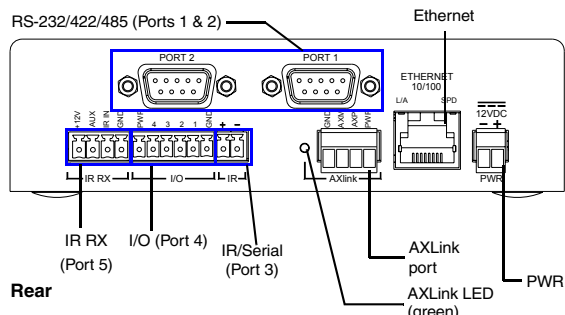

FIG. 2 NI-700 rear connectors and components

Wiring a Power Connection

Use a 12 VDC-compliant power supply to provide power to the NI-700 through the rear 2-pin 3.5 mm mini-Phoenix connector (FIG. 2). Use the previous power requirements information to determine the power draw.

The incoming PWR and GND cable from the power supply must be connected to their corresponding locations within the PWR connector. Refer to the *NetLinX Integrated Controllers* Instruction Manual for more detailed wiring connection information.

RS-232/422/485 Wiring Connector Information

FIG. 3 shows the pinout and wiring specification information for the rear RS-232/RS-422/RS-485 (DB9) Device Ports. These ports support most standard RS-232 communication protocols for data transmission (NI-700 uses Ports 1 & 2).

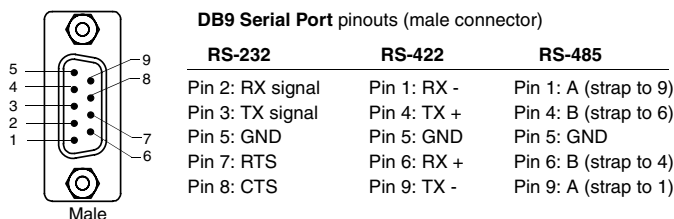

FIG. 3 RS-232/422/485 DB9 (male) connector pinouts

WARNING: When wiring the 422/485 connections, do **NOT** use pre-made 9-wire cable or connect the wire in the cable to any connection that will not be used by the DB9 serial port. Only use wiring that connects the needed pins.

Ethernet 10/100 Base-T Connector

A standard CAT5 Ethernet cable provides 10/100 network connectivity between the Integrated Controller and the network (FIG. 4).

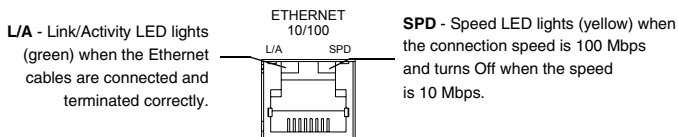

FIG. 4 Layout of Ethernet LEDs

Note: On *NetLinX Masters* (such as those aboard the NI-700), from within the *Telnet* or *Terminal* applications; you can send the **SET ETHERNET MODE** command to assign the speed of your Ethernet connection.

Sample NI-700 command:

```
SET ETHERNET MODE AUTO
```

The NI-700 only allows you to set the Ethernet mode to AUTO negotiate the Ethernet connection speed. Using any of the other connection modes (10 Half/Full or 100 Half/Full) results in an error message.

Program Port Baud Rate Settings

The Configuration DIP switch is located on the front panel. Use this DIP switch to set the baud rate for the Program Port, according to the settings shown in the following table. Make sure the baud rate you set matches the baud rate on your PC's NetLinX COM Settings before programming the unit.

By default, the baud rate is set to 38,400 (bps).

Note: DIP switch 1 activates/deactivates the Program Run Disable Mode. DIP Switches 2,3, and 4 must remain OFF at all times.

| Baud Rate Settings | | | | |
|----------------------|------------|------------|------------|------------|
| Baud Rate | Position 5 | Position 6 | Position 7 | Position 8 |
| 9600 bps | OFF | ON | OFF | ON |
| 38,400 bps (default) | OFF | ON | ON | ON |
| 57,600 bps | ON | OFF | OFF | OFF |
| 115,200 bps | ON | ON | ON | ON |

Setting the Configuration (Program Port) DIP Switch

1. Disconnect the power supply from the rear 2-pin PWR (green) connector.
2. Set DIP switch positions according to the information listed in the previous Baud Rate Settings table.
3. Reapply power to the unit.

Preparing the NI-700 for Serial Communication

1. Launch NetLinX Studio 2.x (default location is **Start > Programs > AMX Control Disc > NetLinX Studio 2 > NetLinX Studio 2**).
2. Select **Settings > Master Communication Settings**, from the Main menu, to open the *Master Communication Settings* dialog box.
3. Click the **Communications Settings** button to open the *Communications Settings* dialog.
4. Click the **NetLinX Master** radio button (from the Platform Selection section) to indicate you are working with a NetLinX Master.
5. Click the **Serial** radio button (from the Transport Connection Option section) to indicate you are connecting to the Master via a COM port.
6. Click the **Edit Settings** button (on the *Communications Settings* dialog) to open the *Serial Settings* dialog and set the COM port parameters (used to communicate to the NetLinX Master).
7. Click the **OK** button three times to return to the main application.
8. Right-click the entry in the **Online Tree** tab and select **Refresh System**.
9. Assign a System Value by using **Diagnostics > Device Addressing** from the Main menu.
10. Enable the **Change System** selection by clicking on it and then enter the current and new System values.
11. Click the **Change Device/System Number** button and when finished click **Done**.
12. Select **Tools > Reboot the Master Controller** to access the *Reboot the Master* dialog, then click **Reboot** to restart the Master and incorporate any changes.
13. Once the dialog replies with "Reboot of system complete", click **Done** and then click the **OnLine Tree** tab in the Workspace window to view the devices on the System. *The default System value is one.*
14. Right-click on the *Empty Device Tree/System* entry and select **Refresh System** to re-populate the list.

Configuring the NI-700 for Ethernet Communication

Before continuing, complete the COM port steps above.

1. Connect an Ethernet cable to the unit's rear Ethernet connector.
2. Select **Diagnostics > Network Address** from the Main menu and enter the System, Device (*0 for a Master*), and Host Name information.
3. To configure the Address:
 - Use a DHCP Address by selecting the **Use DHCP** radio button, then click the **GET IP** button (*to obtain a DHCP Address from the DHCP Server*), click the **SET IP Information** button (*to retain the new address*), and then finish the process by clicking the **Reboot Master > OK** buttons.
 - Use a Static IP Address by selecting the **Specify IP Address** radio button, enter the IP parameters into the available fields, then click the **SET IP Information** button (*to retain the pre-reserved IP Address to the Master*), and then click the **Reboot Master > OK** buttons to finish the process.
4. Repeat steps 1 - 5 from the previous section but rather than selecting the **Serial** option, choose **TCP/IP** and edit the settings to match the IP Address you are using (whether Static or IP).
5. Click on the **Authentication Required** radio box (*if the Master is secured*) and press the **User Name and Password** button to enter a valid username and password being used by the secured Master.
6. Click the **OK** button three times to return to the main application.