

2015/16

A&D

A&D Weighing

PRICE LIST

Prices effective from April 2015

All A&D Products are available through your local A&D Authorised Dealer



Weighing & Measurement Equipment

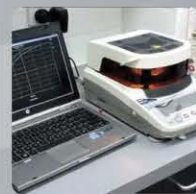

A&D Weighing's product range includes industrial scales, platform and counting scales, warehouse scales, automatic checkweighers, load cells, weight displays and indicators, scientific laboratory balances, viscometers, moisture analysers, dynamic weighing systems and weight capture software. With a long local history, A&D's weighing instruments are a common sight in Australian factories, warehouses and laboratories. Local manufacturing, combined with our global experience should make A&D your first choice in measurement instrumentation and process control know-how.

Warranty

The period of warranty is indicated for each product of this catalogue: 5 years (in case of products with SHS sensor), 3 years, or 1 year. For options and accessories, the warranty is 1 year whatever the product.



SHS sensor: Speed, Precision, and Robustness



A&D developed this new sensor named Super-Hybrid-Sensor. SHS is a hybrid body that combines the fulcrum and beam used in an electromagnetic force motor type sensor and a Roberval body built as one single block. This innovative approach (patent pending) enables precision with faster response time, and robustness.

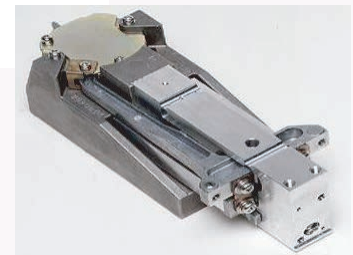

Signs and Symbols



"NMI-type approval" for balances and scales that are legal for trade. Series bearing this sign have some or all of their models that are approved for trade.



Calibration with built-in motor-driven weight



Shows weight in % in relation to a reference weight



Compares weighing results to limits



Summing of weighing results



Calibration with external weight



Counting function: Shows number of pieces based on their unit weight



Automatic recalculations and adjustment of unit weights during counting



Animal weighing: Weighing of unstable or moving objects



Underhook for suspended weighing (for magnetic, hot, contaminated materials, or density determination)



Complies with GLP guidelines (Good Laboratory Practice)



Data memory



Calendar and clock functions



Beeper function



Possibility to disable some of the keys



Rechargeable batteries



Works with normal batteries



Liquid-crystal display



Liquid-crystal display with backlight



Vacuum fluorescent display

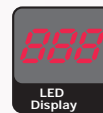

Red LED display



LAN Ethernet interface



USB interface enabling the transfer of weighing results directly into your apps. No need to install any specific software.

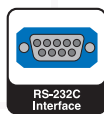

Serial interface to PC, printer and other peripherals



WinCT software - data acquisition - remote control - generating graphs - data directly into your chosen applications



IP54-level protection against water and dust



IP65-level protection against water and dust



IP68-level protection against water and dust



Highest protection against water and dust (suitable for cleaning with pressure jets and hot water)



Meets sanitary guidelines established by NSF



Enables free editing of serial output format or printout format

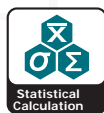

Statistical functions



Auto switch between precision range and standard range. You can tare and still enjoy the full precision range

Table of Contents

LABORATORY & ANALYTICAL BALANCES

HR-A / HR-AZ Series	3
BM Series	4
GH / GR Series	5
FX-i / FX-iWP Series	6
FZ-i / FZ-iWP Series	7
GX / GF Series	8
GX-K / GF-K Series	9
GP Series	10

COMPACT BALANCES

HT-120 / HT Series	11
EJ Series	12
EW-i Series	13
EK-i Series	14
EK-L Series	15
SJ-HS Series	16
SJ-WP Series	17
SK-WP Series	18
HL-WP / HJ-150	19

INDUSTRIAL, HEAVY DUTY & WAREHOUSE SCALES

EM Series	20
FG Series	21
HV-G Series	22
HW-G / HV-WP Series	23
SE Series	24
SC Series	25
SW Series	26
FS-Ki Series	27
Baseworks	28
AD-300 / AD-600 Series / SD-200	29
ELP-1200 Pallet Scale	30
A&D 3000 Pallet Scale	31
ELP-3000 Pallet Scale	32
Weighbeams / OHT Scales	33

INDICATORS

AD4401 / AD4402 / AD4404	34
AD4405 / AD4406 / AD4407	35
AD4328 / AD4329 / FSi-D / SW-D	36

INDICATORS

37 AD4408 / AD4410 / AD4532B

37 AD-4541-V/I Signal Conditioners

COUNTING & RETAIL BENCH SCALES

38 SF-KA / SF-KB / SG Series

39 HC-i Series

40 FC-i / FC-Si Series

41 AP-30i Postal Scale

EZI-CHECK CHECKWEIGHERS & METAL DETECTORS

42 Intelligent Checkweigher 2kg

43 Intelligent Checkweigher 6kg

44 EZI-Check Metal Detector

45 Carton Rollers / Dolphin CW

PROCESS CONTROL BOXES

46 Basic, Standard, Intelligent & Custom

PERIPHERALS & LOADCELLS

47 Loadcells

48 AD8121 / AD8920 / AD1683

49 AD1688 / AD8527 / AD1687

TESTING & ANALYTICAL INSTRUMENTS

50 Pipette Testers / Density Kits

51 Moisture Analysers

52 Viscometers

53 MPA Electronic Pipettes

54 AD-4212B System

55 AD-4212C System

56 MC Series

HEALTH, PROFESSIONAL & PERSONAL SCALES

57 Chair Scales / Personal Scales

DEALER SECTION & PRODUCT SUPPORT

58 Verification & Trade Approvals

59 Calibrating & Wiring

60 Additional Product Information / NMI

62 Freight Charges & Breeze Break Info

63 Selection Guide

Table of Contents

HR-A / HR-AZ Series

Compact Analytical Balances



HR-A model

Large removable breeze break with rotary sliding doors



SMART Range 251 models

HR-A: External Calibration
HR-AZ: Internal Calibration

- (HR-AZ) Internal Calibration
- (HR-A) External Calibration
- (HR-AZ) Date & Time
- Counting Function
- VFD Display
- Comparator Function
- GLP Compliant
- SHS Super Hybrid Sensor
- Buzzer
- Underhook
- RS-232C Interface
- Statistical Calculation
- Percentage Function
- Software

Options

- Rechargeable Battery
- LAN-Ethernet Interface
- Quick USB

- **Smart range 251 models 60g x 0.1mg**
- Easy data capture with free WINCT software
- Strong protection against dust & water
- Shock absorber function
- Auto Power ON/OFF function
- B5 size footprint for use in narrow space
- Reverse Backlit LCD Display for easy to read weighing results
- SCF - Statistical calculation function
- Fast compact SHS Sensor, response time of about 2 seconds
- LAN – Ethernet interface with WinCT-Plus Software (optional)
- Easily removable large breeze break

Specifications	HR-250A	HR-251A	HR-250AZ	HR-251AZ
Price (ex GST)	\$1,865	\$1,695	\$2,085	\$1,920
Part Number	06032900	06032802	06032800	06032901
Calibration	External	External	Internal & External	Internal & External
Capacity	252g	62g / 252g ^{iv}	252g	62g / 252g ^{iv}
Resolution	0.1mg	0.1mg / 1mg	0.1mg	0.1mg / 1mg
Dimensions	198 (W) x 294 (D) x 315 (H) mm			
Pan Size	Ø 90mm			
Serial Cable	DB9 Female to DB9 Female (03000007)			
Power Supply	AC Adaptor TB-S139 included			

* iv Smart range function: The minimum weighing value will switch to 1 mg automatically when the display value exceeds 62 g but returns to 0.1 mg by pressing RE-ZERO (tare)

Accessories	Part Number	Price (ex GST)
HR-A OP-02 USB Interface with Cable	06054001	\$195
HR-A OP-08 Ethernet Interface & WinCT Plus	06054002	\$965
HR-A OP-09 Built in Rechargeable Battery	06054003	\$630
AD-1654 Density Determination Kit	06036350	\$1075



BM Series

Micro*, Semi-Micro & Premium Analytical Balances

**Microgram BM models are only available via qualified & trained A&D BM Micro Partners*



Options



Neutralizing chamber

Separator plate (removable)

Weighing Chamber



The green LED is lit when ionizer is on

In built fanless ionizer

To block drafts, A&D adopted a double-ring structure around the weighing pan and two vertical shields under the separation plate. This offers more space and easier operation. The removable separator plate enables the user to have one large chamber if needed.



Optional
AD-1672 Breeze Break
AD-1670 Anti-vibration Table

● Simple data capture with free WINCT software

- Easy, fanless elimination of static electricity using a built-in ionizer & antistatic breeze break
- Large weighing chamber for improved usability
- Built-in temperature, humidity, and atmospheric pressure sensors
- Sensitivity drift (10 °C to 30 °C, when self calibration is not used) ± 2 ppm / °C
- Interlockable slide doors allowing efficient operation with both hands
- Calibration: Automatically triggered based on temperature variation or by operator
- Can store up to 200 sets of weighing data (100 sets with date & time)
- AD-1688 as standard accessory: dedicated USB key to record weighing data as well as environmental parameters into MS Excel readable files
- 12 weighing units : g, mg, oz, ozt, ct, mom, dwt, GN, tael, tola, pcs (counting), %.
- Optional pipette accuracy testing kit
- Output interfaces: RS-232C (standard), Quick USB (standard), Ethernet (optional)

Specifications	BM-20	BM-22	BM-252	BM-200	BM-300	BM-500
Price (ex GST)	\$18,850	\$17,500	\$10,810	\$8,645	\$9,080	\$9,730
Part Number	06035000	06035400	06035300	06035500	06035600	06035700
Calibration	Internal & External	Internal & External	Internal & External	Internal & External	Internal & External	Internal & External
Capacity	22g	5.1g / 22g	250g	220g	320g	520g
Resolution	0.001mg	0.001mg / 0.01mg	0.01mg	0.1mg	0.1mg	0.1mg
Dimensions	259 (W) x 466 (D) x 326 (H) mm				259 (W) x 466 (D) x 326 (H) mm	
Pan Size	Ø 25mm (50 and 95mm for filter pans)		Ø 90mm	Ø 90mm	Ø 90mm	Ø 90mm
Serial Cable	DB9 Female to DB9 Female (03000007)					
Power Supply	AC Adaptor TB-S139 included					

Accessories	Part Number	Price (ex GST)
OP-08 Ethernet interface with WinCT-Plus software	06035002	\$1,185
OP-14 Pipette accuracy testing kit	06035001	\$2,755
AD-1670 Anti-vibration table	06035200	\$2,045
AD-1672 Table-top breeze break	06035100	\$2,150
AD-1653 Density determination kit	06036300	\$1,075

GH & GR Series

Analytical Semi-Micro Balances



Large weigh chamber



● **Easy data capture with free software**

- Wide weighing range for 0.01mg resolution: 101g for GH-252 and 42g for GR-202
- One-Touch automatic calibration with just one push of a button
- Automatic calibration when the balance detects ambient temperature changes
- Standard RS232C interface for PCs, printers or other peripherals
- Antistatic glass (GH only)
- GLP, GMP and ISO compliant
- WinCT Communications software
- Data memory function (GH only)
- ID number for GLP output
- Auto Power Off function

Network Capability
With Option 08 (GH and GR Series) or Ethernet Adapter AD-8526

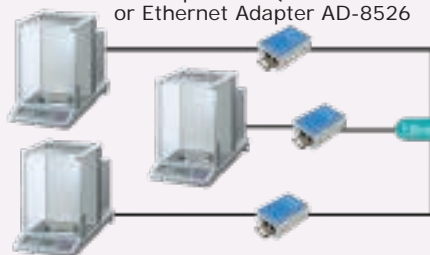

WinCT-Plus software for centralised management of a network of balances



Options GH

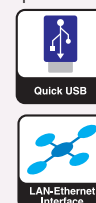

Specifications	GH-252	GR-200	GR-202	GR-300
Price (ex GST)	\$6,485	\$3,455	\$5,835	\$5,405
Part Number	06034900	06034100	06034200	06034300
Calibration	Internal & External	Internal & External	Internal & External	Internal & External
Capacity	250g / 101g	210g	210g / 42g	310g
Resolution	0.1mg / 0.01mg	0.1mg	0.1mg / 0.01mg	0.1mg
Dimensions	217(W) x 442(D) x 316(H)		249(W) x 330(D) x 328(H)	
Pan Size	Ø 90mm		Ø 85mm	
Serial Cable	DB9 Female to DB9 Female (GH) / D25 Female to DB9 Female (GR)			
Power Supply	AC Adaptor TB-S139 included			

Accessories	Part Number	Price (ex GST)
GH OP-02 Quick USB interface (GH)	06034001	\$195
GH OP-08 Ethernet interface (GH)	06034002	\$965
AD-1653 Density Determination Kit	06036300	\$1075
AD-1682 Rechargeable Portable Power Supply (external)	06087210	POA



FXi / FXiWP Series

Precision Balances

- (FX-i-WP)
- External Calibration
- SHS Super Hybrid Sensor
- Percentage Function
- Software
- Comparator Function
- Buzzer
- Animal Weighing
- Counting Function
- GLP Compliant
- RS-232C Interface
- Underhook
- VFD Display



FX-3000i

“There are TWO types of Lab staff... Those who HAVE SPILLED STUFF on their laboratory balance, and those that will!”



FX-300i-WP with standard breeze break

large breeze break option

● Free data capture software

- IP65 Water / Dust Proof (WP)
- Shock absorber function
- Auto Power ON/OFF function
- B5 size footprint for use in narrow space
- VFD Display for easy to read weighing results
- SCF - Statistical calculation function
- Fast compact SHS Sensor, response time only 1 second
- Quick USB or LAN interface (optional)

Options

- Rechargeable Battery
- LAN-Ethernet Interface
- Quick USB

Specifications	FX-300i●	FX-500i●	FX-3000i●	FX-5000i	FX-300iWP●	FX-3000iWP●
Price (ex GST)	\$1,065	\$1,225	\$1,335	\$1,390	\$1,830	\$1,835
Part Number	06054020	06054120	06054050	06054150	06055020	06055050
Calibration	External	External	External	External	External	External
Capacity	320g	520g	3200g	5200g	320g	3200g
Resolution	0.001g	0.001g	0.01g	0.01g	0.001g	0.01g
Dimensions	193(W) x 263(D) x 86(H) mm					
Pan Size	Ø 130mm		Ø 150mm		Ø 130mm	Ø 150mm
Serial Cable	DB9 Male to DB9 Female (03000007 not waterproof)					
Power Supply	AC Adaptor TB-S139 (included)					

● These balances have breeze breaks included

NMI Versions also require trade verification - fees apply

Accessories	Part Number	Price (ex GST)
Optional Square Pan fits 3000/5000 models (approved by NMI) 180mm x 180mm	06054009-E	\$195
FX-i OP-02 USB Interface with cable	06054001	\$195
FX-i OP-08 Ethernet Interface with WinCT Plus	06054002	\$965
FX-i OP-09 Built in Rechargeable Battery	06054003	\$635
FX-i OP-10 Standard Small Breeze Break	06054004	\$200
FX-i OP-11 Large Breeze Break	06054005	\$295
FX-i-WP Standard Small Breeze Break	06054006	\$200
FX-i-WP Large Breeze Break	06054007	\$200
FX-i Plastic Protection Cover (box of 5)	AX-FXI-31	\$65
AD-1654 Density Determination Kit	06036350	\$1,075

FZi / FZiWP Series

Precision Balances



FZ model with standard small breeze break



Firmly Sealed Pan Support with protective membrane (-WP IP65 models)



Large Breeze Break (option)



Square pan (option)

Trade Approval
NMI #6/4C/269



(FZ-i-WP)



● Free data capture software

- NMI trade approved model
- IP65 Water / Dust Proof (WP)
- Built-in internal calibration at the touch of a button
- Auto Power ON/OFF function
- B5 size footprint for use in narrow space
- VFD Display for easy to read weighing results
- SCF - Statistical calculation function
- Standard RS-232C
- Fast compact SHS Sensor, response time only 1 second
- Quick USB or LAN interface (optional)

Options



Specifications	FZ-300i •	FZ-500i •	FZ-3000i •	FZ-5000i •	FZ-300iWP •	FZ-3000iWP •
Price (ex GST)	\$1,285	\$1,445	\$1,660	\$1,765	\$2,155	\$2,155
Part Number	06056010	06056110	06056020	06056120	06056030	06056040
Price with NMI kit	\$1,395	N/A	\$1,770	N/A	\$2,265	\$2,265
Part Number	06056010TA	N/A	06056020TA	N/A	06056030TA	06056040TA
Calibration	Internal & External	Internal & External	Internal & External	Internal & External	Internal & External	Internal & External
Capacity	320g	520g	3200g	5200g	320g	3200g
Resolution	0.001g	0.001g	0.01g	0.01g	0.001g	0.01g
Dimensions	193(W) x 263(D) x 86(H) mm					
Pan Size	Ø 130mm		Ø 150mm		Ø 130mm	Ø 150mm
Serial Cable	DB9 Male to DB9 Female (03000007 not waterproof)					
Power Supply	AC Adaptor TB-S139 (included)					

● These balances have breeze breaks included

NMI Versions also require trade verification - fees apply

Accessories	Part Number	Price (ex GST)
Optional Square Pan fits 3000/5000 models (approved by NMI) 180mm x 180mm	06054009-E	\$195
FZ-i OP-02 USB Interface with cable	06054001	\$195
FZ-i OP-08 Ethernet Interface with WinCT Plus	06054002	\$965
FZ-i OP-09 Built in Rechargeable Battery	06054003	\$635
FZ-i OP-10 Standard Small Breeze Break	06054004	\$200
FZ-i OP-11 Large Breeze Break	06054005	\$295
FZ-i-WP Standard Small Breeze Break	06054006	\$200
FZ-i-WP Large Breeze Break	06054007	\$200
FZ-i Plastic protection cover (box of 5)	AX-FX1-31	\$65
AD-1654 Density Determination Kit	06036350	\$1,075



GX / GF Series

Precision Balances



Trade Approval
NMI #6/4C/219



(GX)



(GF)

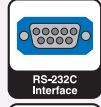
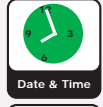

GX-400
(with optional Glass Breeze Break)

GX-600
(with Standard Breeze Break)

GX-6100

Options



● Easy data capture with free WinCT software

- Fast - response time just ONE second!
- Automatic internal calibration (GX): simply push one button
- External manual calibration (GF)
- Percentage Counting and Comparator function
- ACAI Automatic counting accuracy improvement
- Data memory function
- GLP, GMP and ISO compliance



Quick reference card

Specifications	GX-200	GX-400	GX-600	GX-800	GX-1000	GX-2000	GX-4000	GX-6100	GX-8000
Price (ex GST)	\$2,050	\$2,155	\$3,235	\$3,780	\$4,265	\$2,045	\$2,155	\$3,240	\$1,885
Part Number	06052007	06052006	06052005	06052008	06052009	06052004	06052000	06052002	06052001
Price with NMI kit	\$2,160	\$2,265	\$3,345	N/A	N/A	\$2,155	\$2,265	\$3,350	\$1,995
Part Number	06052007TA	06052006TA	06052005TA	N/A	N/A	06052004TA	06052000TA	06052002TA	06052001TA
Calibration	Internal calibration with internal mass								
Capacity	210g	410g	610g	810g	1000g	2100g	4100g	6100g	8100g
Resolution	0.001g	0.001g	0.001g	0.001g	0.001g	0.01g	0.01g	0.01g	0.1g
Dimensions	210 (W) x 317(D) x 86(H) mm								
Pan Size	128mm x 128mm				165mm x 165mm				
Serial cable	DB25 Male to DB9 Female (03000001)								
Power Supply	AC Adaptor TB-S139 (included)								

NMI Versions also require trade verification - fees apply
 ex Japan

Specifications	GF-300	GF-400	GF-1200	GF-3000	GF-4000	GF-6100	GF-6000
Price (ex GST)	\$1,835	\$1,940	\$1,725	\$1,835	\$1,945	\$2,935	\$1,510
Part Number	06052200	06052300	06052600	06052800	06052400	06052901	06052900
Price with NMI kit	\$1,945	\$2,050	\$1,735	\$1,945	\$2,055	\$3,045	\$1,620
Part Number	06052200TA	06052300TA	06052600TA	06052800TA	06052400TA	06052901TA	06052900TA
Calibration	External manual calibration						
Capacity	310g	410g	1210g	3100g	4100g	6100g	6100g
Resolution	0.001g	0.001g	0.01g	0.01g	0.01g	0.01g	0.1g
Dimensions	210 (W) x 317(D) x 86(H) mm						
Pan Size	128mm x 128mm			165mm x 165mm			
Serial Cable	DB25 Male to DB9 Female (03000001)						
Power Supply	AC Adaptor TB-S139 (included)						

NMI Versions also require trade verification - fees apply
 ex Japan

GX/GF Accessories on next page

GX-K / GF-K Series

Industrial Precision Balances



Rugged Construction



Water protected
Dust protected

Trade Approval
NMI #6/4C/219



(GX-K)



(GX-K
GF-K)

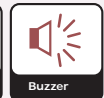
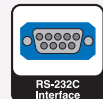

● Free data capture software

- IP65 – Water and dust proof
- Fast response time with Super Hybrid Sensor (SHS) – only 1.5 seconds
- One touch Automatic calibration with motor-driven internal calibration mass (GX-K)
- Standard RS-232C Interface
- GLP, GMP and ISO compliant
- Automatic self calibration when the ambient temperature changes (GX-K)
- Underhook weighing (for thermal /magnetic samples, or density measurement)
- Display auto power off function

Specifications	GX-8K	GX-8K2	GX-10K	GX-20K	GX-30K	GF-8K	GF-10K	GF-12K	GF-30K
Price (ex GST)	\$4,325	\$3,295	\$4,510	\$4,295	\$5,075	\$4,105	\$4,315	\$3,965	\$4,755
Part Number	06062100	06062900	06062800	06062500	06062700	06062000	06062300	06062200	06062600
Price with NMI kit	\$4,435	N/A	\$4,620	\$4,405	\$5,185	N/A	N/A	N/A	N/A
Part Number	06062100TA	N/A	06062800TA	06062500TA	06062700TA	N/A	N/A	N/A	N/A
Calibration	Internal	Internal	Internal	Internal	Internal	External	External	External	External
Capacity	8.1kg	8.1kg / 2.1kg	10.1kg	21kg	31kg	8.1kg	10.1kg	12kg	31kg
Resolution	0.01g	0.1g / 0.01g	0.01g	0.1g	0.1g	0.01g	0.01g	0.1g	0.1g
Dimensions	300(W) x 355(D) x 111(H) mm								
Pan Size	270mm x 210mm								
Power Supply	AC Adaptor TB-S139 (included)								

NMI Versions also require trade verification - fees apply
● ex Japan

Accessories	Part Number	Price (ex GST)
GFX/K OP-04 Comparator output and buzzer	06052504	\$495
GFX/K OP-06 Analog/current loop output	06052505	\$1,575
GFX OP-10 Glass breeze break (200g to 600g)	06052503	\$600
GFX OP-11 Glass breeze break (2000g to 8000g)	06052502	\$600
GFX OP-12 Animal weighing pan	06052501	\$375
GFX OP-13 Density determination kit	06052500	\$1,025
GFX Plastic Cover (200/300/400/600g) (pack of 5)	AX-073003691-S	\$105
GFX Plastic Cover (1200g to 8000g) (pack of 5)	AX-073003692-S	\$105
Protective Cover for GX/F-K (pack of 5)	AX-073007197-S	\$105



GP Series

Industrial Precision Balances

NMI Trade Approval
NMI #6/4C/220

SHS Super Hybrid Sensor

Underhook

Internal Calibration

Comparator Function

Counting Function

VFD Display

Percentage Function

Accumulation Function

SmartRange

IP65

GLP Compliant

Animal Weighing

RS-232C Interface

Software

- Easy data capture with free WINCT software
- Australia's #1 Geo-test balance!
- Swing arm design or separate display design
- IP65 protected
- Easy calibration with internal calibration mass
- SHS response speed of only 1.5 seconds
- GLP, GMP and ISO compliant
- Large Vacuum Fluorescent Display
- Data memory function
- Counting function with ACAI (Automatic Counting Accuracy Improvement)
 - Smart range function (GP-32K/102K)
 - Comparator function
 - Underhook weighing for thermal and magnetic samples as well as for density calculation

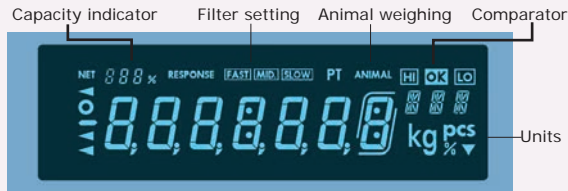

Option

Buzzer

Specifications	GP-12KA	GP-20KA	GP-30KA	GP-32KA	GP-30KS	GP-32KS
Price (ex GST)	\$4,645	\$5,295	\$5,835	\$4,970	\$5,835	\$5,185
Part Number	06072001	06072002	06072004	06072008	06072010	06072011
Price with NMI kit	\$4,755	\$5,405	\$5,945	\$5,080	\$5,945	\$5,295
Part Number	06072001TA	06072002TA	06072004TA	06072008TA	06072010TA	06072011TA
Calibration	Internal & External	Internal & External	Internal & External	Internal & External	Internal & External	Internal & External
Capacity	12kg	21kg	31kg	6kg/31kg	31kg	6kg/31kg
Resolution	0.1g	0.1g	0.1g	0.1g / 1g	0.1g	0.1g / 1g
Dimensions	372(W) x 615(D) x 130(H) mm					
Pan Size	384mm x 344mm			386mm x 346mm		
Serial Cable	DB25 Male to DB9 Female (03000001)					
Power Supply	AC Adaptor TB-301 (included)					

Specifications	GP-40KA	GP-61KA	GP-60KS	GP-61KS	GP-100KA	GP-102KA
Price (ex GST)	\$6,485	\$7,565	\$6,370	\$7,565	\$9,680	\$8,595
Part Number	06072005	06072009	06072012	06072013	06072006	06072007
Price with NMI kit	N/A	N/A	\$6,480	N/A	\$9,790	\$8,705
Part Number	N/A	N/A	06072012TA	N/A	06072006TA	06072007TA
Calibration	Internal & External	Internal & External	Internal & External	Internal & External	Internal & External	Internal & External
Capacity	41kg	61kg	61kg	61kg	101kg	61kg/101kg
Resolution	0.5g	0.1g	1g	0.1g	1g	1g / 10g
Dimensions	373(W) x 615(D) x 130(H) mm					
Pan Size	384mm x 344mm		386mm x 346mm			
Serial Cable	DB25 Male to DB9 Female (03000001)					
Power Supply	AC Adaptor TB-301 (included)					

NMI Versions also require trade verification - fees apply
 ● ex Japan

Accessories	Part Number	Price (ex GST)
GP OP-04 Comparator Output/RS232C	06072104	\$490
GP OP-06 Analog / Current Loop Output ●	06052505	\$1,575
GP OP-20 Underhook (for GP12K/20K/32K/30K/40K)	06072120	\$410
GP OP-21 Underhook (for GP60K/100K/100KS/102K)	06072121	\$410
Plastic Cover for GP Display (Pack of 5)	10-73004753-5S	\$105

● ex Japan

HT Series

Precision Compact Balances



HT-120 model

HT Compact scale

BEST VALUE

NEW MODELS

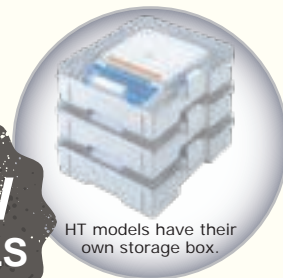

HT models have their own storage box.



Stainless Steel Pan Option



- HT-120 has hygienic and chemically resistant stainless steel (SUS304) weighing pan and protector plate
- HT-120 has resolution of 0.01 g with excellent repeatability of 0.01 g (σ)
- Large LCD display (15 mm character height) with clear white backlight
- Three colour bars to sort / colour code scales easily (except HT-120)
- Stackable carrying case for easy storage
- Security slot in the rear of the scale to accommodate an anti-theft lock
- HT-120 units: g, oz, ct, mom, ozt, grain, tola, tael, and Newton
- HT units: g, oz, ozt, tola, tael
- Auto-power off function to avoid wasting battery power
- Power supplied from 4 AA batteries
- Battery indicator that tells you the remaining battery level
- Tare function that offsets the weight of a container with just one key press
- Optional AC adapter available



Stackable carry cases

Specifications	HT-120	HT-300	HT-500	HT-3000	HT-5000
Price (ex GST)	\$180	\$105	\$135	\$105	\$135
Part Number	06315000	06311000	06312000	06313000	06314000
Calibration	External	External	External	External	External
Capacity	120g	310g	510g	3100g	5100g
Resolution	0.01g	0.1g	0.1g	1g	1g
Dimensions	160(W) x 175(D) x 70(H)	195(W) x 136(D) x 44(H) mm			
Pan Size	Ø 70mm	132mm x 130mm			
Power Supply	AC Adaptor TB-S200 (not included) or 4 x AA batteries (included)				

Accessories	Part Number	Price (ex GST)
Stainless Steel Pan Option for standard HT Series	06311010	\$45
Optional AC Adaptor	ECTB-S200	\$70



EJ Series

Compact Scales



EJ-1500



EJ-303 MODEL



Options



- Counting, % weighing, comparator
- Calculates density automatically (option EJ-13)
- Hygienic and rustproof stainless steel pan
- Stackable body to save storage space
- Easy PC connection with optional RS232 cable and **FREE SOFTWARE**
- Supports multiple weighing units



EJ-13 Density kit



EJ-11 Breeze break



EJ-12



Stackable body for easy storage and saving space

Specifications	EJ-210	EJ-410	EJ-123	EJ-303	EJ-610	EJ-1500	EJ-4100	EJ-6100
Price (ex GST)	\$480	\$640	\$610	\$750	\$750	\$480	\$640	\$750
Part Number	06044010	06044030	06044123	06044303	06044040	06044050	06044080	06044090
Calibration	External	External	External	External	External	External	External	External
Capacity	210g	410g	120g	303g	610g	1500g	4100g	6100g
Resolution	0.01g	0.01g	0.001g	0.001g	0.01g	0.1g	0.1g	0.1g
Dimensions	190(W) x 208(D) x 59(H) mm					190(W) x 208(D) x 59(H) mm		190(W)x211(D)x126(H)
Pan Size	Ø110mm					127mm x 140mm		
Serial Cable	DB9 Female to DB9 Female (03000007)							
Power Supply	4 x AA size batteries (not included) or AC Adaptor TB-S200 (included)							

Accessories	Part Number	Price (ex GST)
EJ OP-02 Quick USB Interface	06044001	\$155
EJ OP-03 RS-232C Interface	06044002	\$110
EJ OP-07 Underhook for EJ-4100/6100	06044003	\$85
EJ OP-08 Underhook for EJ-1500/2000	06044004	\$85
EJ OP-11 Tilting Breeze Break (included with EJ-123/303)	06044005	\$115
EJ OP-12 Carry Case for EJ Series (not suited to EJ-123/303)	06044006	\$160
EJ OP-13 Density Determination Kit	06044007	\$160

EW-i Series

Value Compact Balances



Trade Approval
NMI #6/4C/219



EW-1500i Balance

- **Free WINCT software available**
 - Advanced, triple range balances
 - Capacities to 12kg
 - Large back lit LCD display with wide viewing angle
 - Standard RS232C data interface
 - Overload protected to take hard use
 - 9 built in weighing units plus counting and percentage software
 - Standard comparator function with LO/GO/HI indication
 - Full digital calibration with user definable calibration mass
 - Conforms with GLP standards
 - Stainless steel weighing pan
- Optional rechargeable battery pack
- Optional under hook weighing for 12kg model

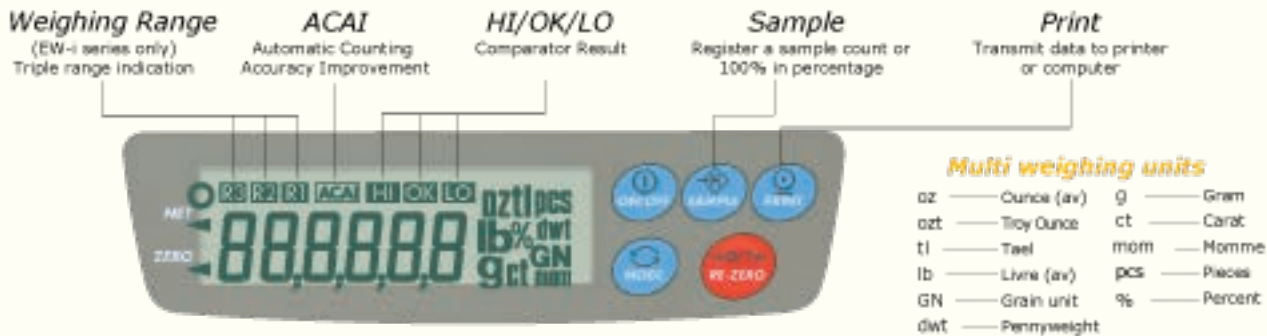

Specifications	EW-150i			EW-1500i			EW-12Ki		
Price (ex GST)	\$535			\$535			\$535		
Part Number	06043700			06043800			06043900		
Capacity	30g	60g	150g	300g	600g	1500g	3000g	6000g	12Kg
Resolution	0.01g	0.02g	0.05g	0.1g	0.2g	0.5g	1g	2g	5g
Price with NMI kit	\$645			\$645			\$645		
Part Number	06043700TA			06043800TA			06043900TA		
Capacity	60g	150g		300g	600g	1500g	3000g	6000g	12Kg
Resolution	0.02g	0.05g		0.1g	0.2g	0.5g	1g	2g	5g
Dimensions	190(W) x 218(D) x 55(H) mm			190(W) x 218(D) x 53(H) mm					
Pan Size	Ø 110mm			133 mm x 170 mm					
Serial Cable	DB25 male to DB9 Female (03000001)								
Power Supply	AC Adapter TB-S200 (included) or rechargeable battery pack (not included)								

*NMI Versions also require trade verification - fees apply

Accessories	Part Number	Price (ex GST)
EKWi OP-04 Comp/Relay Output	06043001	\$315
EKWi OP-07 Underhook for 6000g/12kg models only	06041004	\$210
EKWi OP-09 Rechargeable battery pack (Ni-MH)	06043003	\$315
Protective Cover for EKWi (pack of 5)	AX-3005824-5S	\$75



EK-i Series

Industrial Compact Balances



Trade Approval
NMI #6/4C/243

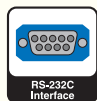

Options



Trade Approved & Great Value!

● **Free downloadable WinCT software available**

- NMI approved (most models)
- Standard RS-232C interface
- Large LCD display with backlight
- GLP compliance
- Overload protection
- Standard comparator function
- Optional rechargeable battery pack



EK Battery Pack Option

- 9 Weighing units plus count and percentage mode
- Counting function with automatic counting accuracy improvement (ACAI)



EK-i Balance

Specifications	EK-410i	EK-610i	EK-3000i	EK-4100i	EK-6100i	EK-6000i	EK-12Ki
Price (ex GST)	\$795	\$965	\$750	\$795	\$965	\$795	\$965
Part Number	06042101	06042201	06043400	06042301	06042401	06043500	06043600
Capacity	400g	600g	3000g	4000g	6000g	6000g	12kg
Resolution	0.01g	0.01g	0.1g	0.1g	0.1g	1g	1g
Price with NMI kit	\$905	\$1075	N/A	\$905	\$1075	N/A	N/A
Part Number	06042101TA	06042201TA	N/A	06042301TA	06042401TA	N/A	N/A
Capacity	400g	600g	N/A	4000g	6000g	N/A	N/A
Resolution	0.1g	0.1g	N/A	1g	1g	N/A	N/A
Calibration	External	External	External	External	External	External	External
Dimensions	190(W) x 218(D) x 55(H)						
Pan Size	Ø 110mm		133mm x 170mm				
Serial Cable	DB25 Male to DB9 Female (03000001)						
Power Supply	AC Adaptor TB-S200 (included) or rechargeable battery pack (not included)						

NMI Versions also require trade verification - fees apply

Accessories	Part Number	Price (ex GST)
EKWi OP-04 Comp/Relay Output	06043001	\$315
EKWi OP-07 Underhook for 6000g/12kg models only	06041004	\$210
EKWi OP-09 Rechargeable battery pack (Ni-MH)	06043003	\$315
Protective Cover for EKWi (pack of 5)	AX-3005824-5S	\$75

EK-L Series

Compact Industrial Scales



Available in 2015

● **Free downloadable WinCT software available**

- Large weighing pan for efficient measurement of bulky products
- Stainless steel SUS430 weighing pan cover
- Multiple weighing units: g, kg, oz, lb, ozt
- Percentage Counting and Comparator function
- ACAI Automatic counting accuracy improvement
- RS-232C interface as standard
- GLP, GMP and ISO compliance

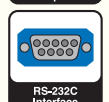

Options



Specifications	EK-15KL	EK-30KL	
Price (ex GST)	\$995	\$995	
Part Number	06045100	06045200	
Calibration	External	External	
Capacity	15kg	3kg	30kg
Resolution	0.1g	0.1g	1g
Dimensions	315(W) x 339 (D) x 130(H) mm		
Pan Size	300mm x 210 mm		
Serial Cable	DB9 Male to DB9 Female (03000007)		
Power Supply	AC Adaptor TB-S200 (included) or rechargeable battery (not included)		

Accessories	Part Number	Price (ex GST)
Rechargeable Battery option	Please Inquire	\$POA

NEW 2015 PRODUCT! Please talk to your Account Manager for more information



SJ-HS Series

Compact Bench Scales



Trade Approval
NMI #6/4C/255



- Stainless steel weighing pan
- Fast stability time - less than 1 second
- Multiple weighing units – g, lb, oz and lb-oz
- Level bubble and adjustable feet for precise levelling
- Battery or AC adapter operation
- Designed to last:
 - Feet do not fall at the end of the thread
 - 4 well protected points of support under the pan

NON TRADE MODELS

Specifications	SJ-1000HS	SJ-2000HS	SJ-5000HS	SJ-12KHS	SJ-5001HS	SJ-20KHS	SJ-30KHS
Price (ex GST)	\$265	\$265	\$265	\$265	\$290	\$290	\$290
Part Number	06303040	06304050	06304060	06304070	06304080	06305000	06305010
Calibration	External	External	External	External	External	External	External
Capacity	1000g	2000g	5000g	12kg	5000g	20kg	30kg
Resolution	0.5g	1g	2g	5g	1g	10g	20g
Dimensions	265(W) x 250(D) x 106(H) mm						
Pan Size	230mm x 190mm						
Serial Cable	n/a						
Power Supply	AC Adaptor TB-S200 (included) or 4 x D size batteries (not included)						

TRADE APPROVED MODELS

Specifications	SJ-1000HS	SJ-2000HS	SJ-5000HS	SJ-12KHS
Price with NMI kit	\$290	\$290	\$290	\$290
Part Number	06303000TA	06303010TA	06303020TA	06303030TA
Calibration	External	External	External	External
Capacity	1000g	2000g	5000g	10kg / 12kg
Resolution	1g	2g	5g	10g / 20g
Dimensions	265(W) x 250(D) x 106(H) mm			
Pan Size	230mm x 190mm			
Power Supply	AC Adaptor TB-S200 (included) or 4 x D size batteries (not included)			



4 x D size batteries

NMI Versions also require trade verification - fees apply

SJ-WP Series

Waterproof Packing Scales



Trade Approval
NMI #6/4C/288

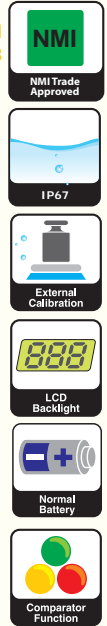

SJ-WP improves packing efficiency compared to standard scales

A Scale you can SOAK!



- 5000hrs of continuous operation on 6D cell batteries
- Fast stabilisation (just 0.5 seconds!)
- Stainless weighing pan
- Submersible IP67 protection
- Large & Clear LCD Display (26mm)
- Multiple selectable weighing units: g, lb, oz, ozt, tael etc.
- Touch sensitive capacitive keys
- Auto power off function
- Bright and multicoloured LED comparator lamps

Specifications	SJ-3000WP	SJ-6000WP	SJ-15KWP	SJ-30KWP
Price (ex. GST)	\$485	\$485	\$485	\$485
Part Number	06305200	06305300	06305400	06305500
Product Description	External	External	External	External
Capacity	3000g	6000g	15kg	30kg
Resolution	0.5g	1g	2g	5g
NMI Resolutions	1.5kg x 0.5g 3kg x 1g	3kg x 1g 6kg x 2g	6kg x 6g 15kg x 5g	15kg x 5g 30kg x 10g
Dimensions	236(W) x 260(D) x 148(H) mm			
Pan Size	232mm x 192mm			
Serial Cable	n/a			
Power Supply	6 x D size batteries			



SK-WP Series

Stainless Steel Bench Scales



Trade Approval
NMI #6/4C/216



Easy to wash after use!



● **NMI Trade Approved except for SK-5001WP**

- Dust and water proof (IP65)
- Stainless steel body and Weighing Pan
- Large & Clear LCD Display (25mm)
- 1/2000 Resolution (SK-5001WP: 1/5000)
- Net Weight / Stability Indication
- Portable (6 x D Type Batteries not included)
- Long battery life: Approx. 1200 hours with alkaline cells at 20°C



Specifications	SK-1000WP	SK-2000WP	SK-5000WP	SK-5001WP	SK-10KWP	SK-20KWP
Price (ex GST)	\$590	\$590	\$590	\$590	\$590	\$590
Part Number	06400100	06400200	06400300	06400600	06400400	06400500
Capacity	1000g	2000g	5000g	5000g	10000g	20000g
Resolution	0.5g	1g	2g	1g	5g	10g
Dimensions	266(W) x 280(D) x 156(H) mm					
Pan Size	232mm x 192mm					
Power Supply	AC Adaptor TB-S200 (included) or 6 x D size batteries (not included)					

*NMI Versions also require trade verification - fees apply

HL-WP Series

Professional Catering Scales



- Washable body made of stainless steel and protected to IP-65
- Only HL-3000LWP comes with larger flat pan
- Portable - powered by 6 x AA size batteries (not included)
- Clear Liquid Crystal Display (LCD)

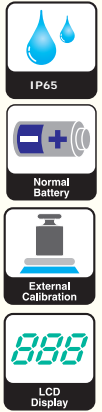

Specifications	HL-300WP	HL-1000WP	HL-3000WP	HL-3000LWP
Price (ex GST)	\$460	\$460	\$460	\$485
Part Number	06410100	06410200	06410300	06410400
Capacity	300g	1000g	3000g	3000g
Resolution	0.1g	0.5g	1g	1g
Dimensions	170(W) x 220(D) x 63(H) mm			174(W) x 220(D) x 63(H) mm
Pan Size	128mm x 128mm			174 x 137mm
Power Supply	6 x AA size batteries (not included) or AC Adaptor TB-S200 (not included)			

HJ-150 Series

Mini Pocket Scales



- Compact design & Light Weight
- Selectable Weighing Unit
- Tare Function
- Calibration Mass Included



Specifications	HJ-150
Price (ex GST)	\$80
Part Number	06310700
Capacity	150g
Resolution	0.1g
Dimensions	66(W) x 98(D) x 20(H) mm
Pan Size	60mm x 64mm
Power Supply	2 x AAA size batteries included



EM Series

Value Parcel Scales

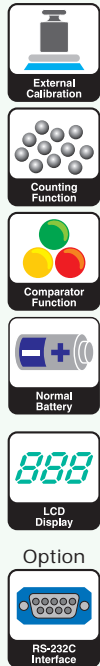

Optional desk bracket and Optional Tilting Indicator Bracket for a wider viewing angle!

Extra discounts for BULK orders!

- **Three selectable resolutions - Fine, Super-fine, Standard (Default is FINE)**
- High Resolution Mode Selectable: 5g Accuracy on EM-30KAM, 10g Accuracy on EM-60KAL, 20g Accuracy on EM-150KAL
- Clearly Visible Display with White Backlight
- Battery Powered (Battery can be charged while the scale is in use)
- Portable Lightweight Body
- Auto Power Off (scale switches off automatically after a period of inactivity)
- Rotating Indicator (to improve viewing display from the back or side)
- Three Platform Sizes (300x 350 mm, 400 x 500 mm and 500 x 600mm)
- Convenient Counting Function (able to count the number of objects with the same weight, based on a predetermined unit weight)

Specifications	EM-30KAM	EM-60KAL	EM-150KAL	EM-300KAX
Price (ex GST)	\$325	\$380	\$380	\$755
Part Number	06500300	06500200	06500100	06500400
Calibration	External	External	External	External
Capacity	30kg	60kg	150kg	300kg
Adjustable Resolution	2g / 5g / 10g	5g / 10g / 20g	10g / 20g / 50g	20g / 50g / 100g
Dimensions	300(W)x560(D)x450(H)	400(W) x 500(D) x 750(H)		500(W)x710(D)x870(H)
Pan Size	300mm x 350mm	400mm x 500mm		500mm x 600mm
Serial Cable	DIN male to DB9 Female (03000002)			
Power Supply	AC Adaptor TB-S200 and internal rechargeable battery (included)			

Accessories	Part Number	Price (ex GST)
EM OP-03 RS232 Interface	06500011	\$55
EM OP-12 Tilting Indicator Bracket	06500012	\$55
EM OP-14 Desktop stand	06500013	\$55
EM OP-17 5m Loadcell extension cable	06500014	\$55
Rechargeable battery	1EBGFP620	\$30

FG Series Platform Scales



Floor Platform &
Bench Mount models!



FG-60KBM

Trade Approval
NMI #6/9C/289



Options

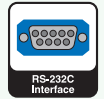

- **NMI Trade Approved except for Hi-Res 31K model**
- AC Adapter or battery operated (4 x C type dry-cell batteries)
- Three selectable weighing resolutions
- Display column and Tilt display pod (FG-KA only)
- Optional RS-232C and Comparator Output (FG-23/FG24)
- Counting function
- Comparator function
- Filtering function
- Full digital calibration
- External Calibration

Specifications	FG-30KAM	FG-30KBM	FG-60KAM	FG-60KBM	FG-150KAM
Price (ex GST)	\$795	\$795	\$795	\$795	\$795
Part Number	03175700	03175750	03175710	03175760	03175720
Calibration	External	External	External	External	External
Capacity	30kg	30kg	60kg	60kg	150kg
Resolution NMI Approved	0.01kg	0.01kg	0.02kg	0.02kg	0.05g
Adjustable Resolution	2g/5g/10g	2g/5g/10g	5g/10g/20g	5g/10g/20g	10g/20g/50g
Dimensions	KAM: 300(W) x 624(D) x 781(H); KBM: 380(W) x 464(D) x 118(H) mm				
Pan Size	330mm x 380mm				
Serial Cable	DIN Male to DB9 Female (03000002)				
Power Supply	AC Adaptor TB-S200 (included) or 4 X C size batteries (not included)				

*NMI Versions also require trade verification - fees apply

Specifications	FG-31KAM	FG-31KBM	FG-60KAL	FG-150KAL	FG-150KBM
Price (ex GST)	\$915	\$915	\$840	\$840	\$795
Part Number	03175790	03175780	03175730	03175740	03175770
Calibration	External	External	External	External	External
Capacity	30kg	30kg	60kg	150kg	150kg
Resolution NMI Approved	non NMI approved models		0.02kg	0.05kg	0.05g
Adjustable Resolution	1g		5g/10g/20g	10g/20g/50g	10g/20g/50g
Dimensions	KAM: 300(W)x624(D)x781(H); KBM: 380(W)x464(D)x118(H); KAL: 390(W)x771(D)x781(H) mm				
Pan Size	330mm x 380mm		390mm x 530mm		330mm x 380mm
Serial Cable	DIN Male to DB9 Female (03000002)				
Power Supply	AC Adaptor TB-S200 (included) or 4 X C size batteries (not included)				

*NMI Versions also require trade verification - fees apply

Accessories	Part Number	Price (ex GST)
FG-23 RS232 Interface option	06145101	\$215
FG-RS232 Interface & Comparator option	06145102	\$245



HV-G Series

Platform Scales

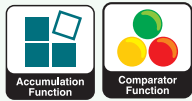
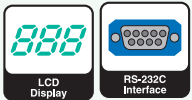

VFD
Display
VFD display
Easy to use in dark areas!



LCD
Display
LCD display



Integrated Printer Option
(Matrix; VFD models only)

- Triple range scales
- High resolution can be changed automatically for 3 capacity levels
- NMI trade approved scale
- Large and clear Displays available as LCD and VFD Display
- M+ function for totalising weighing data
- Programmable setpoints for simple batching
- Optional internal matrix printer (only for VFD Model)
- Standard RS-232C interface
- Counting & percentage function

Specifications	HV-15KGL	HV-60KGL	HV-200KGL	HV-15KGV	HV-60KGV	HV-200KGV
Price (ex GST)	\$1,055	\$1,165	\$1,275	\$1,165	\$1,275	\$1,380
Part Number	03150200	03150300	03150500	03151200	03151300	03151500
Calibration	External			External		
Capacity	15kg/6kg/3kg	60kg/30kg/15kg	220kg/150kg/60kg	15kg/6kg/3kg	60kg/30kg/15kg	220kg/150kg/60kg
Resolution	5g/2g/1g	20g/10g/5g	100g/50g/20g	5g/2g/1g	20g/10g/5g	100g/50g/20g
Dimensions	275(W)x474(D)x368(H)	330(W)x621(D)x771(H)	390(W)x712(D)x773(H)	275(W)x474(D)x368(H)	330(W)x621(D)x771(H)	390(W)x712(D)x773(H)
Pan Size	250mm x 250mm	330mm x 424mm	390mm x 530mm	250mm x 250mm	330mm x 424mm	390mm x 530mm
Serial Cable	DIN Male to DB9 Female (03000002)					
Power Supply	AC Adaptor TB-S200 (included) or 6 x D size batteries (not included)			AC Mains		

*NMI Versions also require trade verification - fees apply

Accessories	Part Number	Price (ex GST)
HV/HW-KG OP-03 RS232C with comparator o/p & buzzer	03141603D	\$430
HV/HW-KG OP-04 RS422/485 with comparator o/p	03141604D	\$430
HV/HW-KG OP-06 Internal printer for HVW-GV only	03141605D	\$755
HV/HW-KG OP-06 Paper rolls	AX-PP-156	\$30
HV/HW-KG Levelling leg	07-3007273	\$30
HV/HW-KG Vinyl cover HVW-G	14-3003217A	\$40

HW-G Series Platform Scales



VFD display
Easy to use
in dark areas!



LCD display

(Base)



Accumulation
Function



Counting
Function



VFD Display



Percentage
Function



LCD
Display

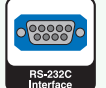

RS-232C
Interface



External
Calibration



Comparator
Function

Option



Buzzer

Specifications	HW-10KGL	HW-60KGL	HW-100KGL	HW-200KGL	HW-10KGV	HW-60KGV	HW-100KGV	HW-200KGV
Price (ex GST)	\$1,055	\$1,165	\$1,275	\$1,275	\$1,165	\$1,275	\$1,380	\$1,380
Part Number	03160100	03160300	03160400	03160500	03161100	03161300	03161400	03161500
Calibration	External				External			
Capacity	10kg	60kg	100kg	220kg	10kg	60kg	100kg	220kg
Resolution	1g	5g	10g	20g	1g	5g	10g	20g
Dimensions	275(W)x474(D)x368(H)	330(W)x621(D)x771(H)	390(W)x712(D)x773(H)		275(W)x474(D)x368(H)	330(W)x621(D)x771(H)	390(W)x712(D)x773(H)	
Pan Size	250mm x 250mm	330mm x 424mm	390mm x 530mm		250mm x 250mm	330mm x 424mm	390mm x 530mm	
Serial Cable	DIN Male to DB9 Female (03000002)							
Power Supply	AC Adaptor TB-S200 (Included) or 6 x D size batteries (not included)				AC Mains			

Accessories	Part Number	Price (ex GST)
HV/HW-KG OP-03 RS232C with comparator o/p & buzzer	03141603D	\$430
HV/HW-KG OP-04 RS422/485 with comparator o/p	03141604D	\$430
HV/HW-KG OP-06 Internal printer for HVW-GV only	03141605D	\$755
HV/HW-KG OP-06 Paper rolls	AX-PP-156	\$30
HV/HW-KG Levelling leg	07-3007273	\$30
HV/HW-KG Vinyl cover HVW-G	14-3003217A	\$40



HV-WP Series Waterproof Platform Scales



- IP65 Protection
- Triple weighing ranges (HV-WP)
- Simple batch function
- Large and clear VFD display
- Adjustable display angle
- Painted Aluminium base

Trade Approval
NMI #6/9C/268



IP65



External
Calibration



Comparator
Function



Counting
Function



Percentage
Function



Accumulation
Function



VFD Display

Options

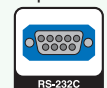

RS-232C
Interface

Specifications	HV-60KGV WP	HV-200KGV WP
Price (ex GST)	\$1,640	\$1,850
Part Number	03150300	03150500
Capacity	60kg/30kg/15kg	220kg/150kg/60kg
Resolution	20g/10g/5g	100g/50g/20g
Dimensions	330(W)x615(D)x786(H)	390(W)x700(D)x786(H)
Pan Size	330mm x 424mm	390mm x 530mm
Serial Cable	DIN Male to DB9 Female (03000002)	
Power Supply	AC Mains	
Accessories	Part Number	Price (ex GST)
OP-03 RS232C with relay output buzzer	03141603D	\$430



SE Series

IP68 Washdown Platform Scales



Trade Approval
NMI #6/4C/276



Painted steel frame and column



SE-60KAL

**Excellent
Resistance
to Hostile
Environments!**

Options

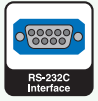

- Water/Dust proof for less than a dry area scale!
- Washdown IP68 construction for easy cleaning
- High speed stabilization of 1 second
- Battery operated (Approx. 5000 hours or 2500 hours if RS-232 is used)
- Supersized LCD of 39 mm character height
- Corrosion-resistant load cell (Aluminium anodized and coated with epoxy resin with protective silicon over wiring)
- Comparator function, Counting function, Automatic power off

Specifications	SE-30KAM	SE-60KAM	SE-150KAM	SE-60KAL	SE-150KAL
Price (ex GST)	\$860	\$860	\$860	\$860	\$860
Part Number	06160900	06161000	06160100	06160300	06160200
Calibration	External	External	External	External	External
Capacity	30kg	60kg	150kg	60kg	150kg
Resolution NMI Approved	10g	20g	50g	20g	50g
Adjustable Resolution	5g/10g	10g/20g	20g/50g	10g/20g	20g/50g
Dimensions	300(W) x 543(D) x 717(H) mm			390(W) x 688(D) x 717(H) mm	
Pan Size	300mm x 380mm			390mm x 530mm	
Serial Cable	Wire connection for terminal to DB9 Female (03000004)				
Power Supply	6 X D size batteries (included)				

*NMI Versions also require trade verification - fees apply

Accessories	Part Number	Price (ex GST)
SCSE OP-02 Quick USB Interface	06160401	\$215
SCSE OP-03 RS-232C + Comparator relay output	06160402	\$320

SC Series

IP68 Washdown Platform Scales



Stainless steel frame and column



Trade Approval
NMI #6/4C/276



Options

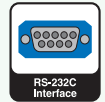

● NMI Trade Approved

- Water/Dust proof for less than a dry area scale!
- Washdown construction for easy cleaning
- High speed stabilization of 1 second
- Battery operated (Approx. 5000 hours or 2500 hours if RS-232 is used)
- IP68 dust and water-proof: Submersible! (1m under water for 24 hours!)
- Supersized LCD of 39 mm character height
- Corrosion-resistant load cell
- Comparator function, Counting function, Automatic power off

Specifications	SC-30KAM	SC-60KAM	SC-150KAM	SC-60KAL	SC-150KAL
Price (ex GST)	\$1,620	\$1,620	\$1,620	\$1,725	\$1,725
Part Number	06160800	06160400	06160500	06160600	06160700
Calibration	External	External	External	External	External
Capacity	30kg	60kg	150kg	60kg	150kg
Resolution NMI Approved	10g	20g	50g	20g	50g
Adjustable Resolution	5g/10g	10g/20g	20g/50g	10g/20g	20g/50g
Dimensions	300(W) x 543(D) x 717(H) mm			390(W) x 688(D) x 717(H) mm	
Pan Size	300mm x 380mm			390mm x 530mm	
Serial Cable	Wire connection for terminal to DB9 Female (03000004)				
Power Supply	6 X D size batteries (included)				

*NMI Versions also require trade verification - fees apply

Accessories	Part Number	Price (ex GST)
SCSE OP-02 Quick USB Interface	06160401	\$215
SCSE OP-03 RS-232C + Comparator relay output	06160402	\$320



SW Series

Super Washdown Scales



Trade Approval
NMI #6/4C/274



Options

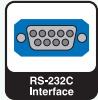

SW Bracket Option



5-level comparator with red / yellow / green lamps

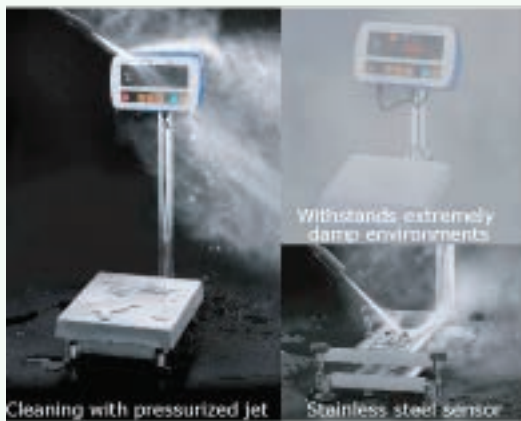

Cleaning with pressurized jet

Withstands extremely damp environments
Stainless steel sensor

NMI TRADE APPROVED
IP69K Stainless steel
Check weighing applications
Food applications
Ergonomic design

- Ultimate protection against the effects of condensation as well as water
- Stainless steel weighing pan, frame and load cell
- Rugged and adjustable (0°, 30°, 60° or 90°) indicator bracket
- Touch sensitive capacitive keys to prevent damage from sharp objects
- Auto-tare function to facilitate consecutive check weighing
- Counting mode function
- Bright, multicolored LED display with 5-step comparator lamps
- Auto power off function
- Three sizes of base units, which are also available separately
- Pole stand attachable to either the short or long side of the platform
- The display unit available separately as an IP69K indicator for high pressure washdown

Specifications	SW-6KS	SW-15KS	SW-15KBM	SW-30KBM	SW-60KAM	SW-150KAM	SW-60KAL	SW-150KAL
Price (ex GST)	\$2,160	\$2,160	\$2,700	\$2,700	\$2,700	\$2,700	\$3,240	\$3,240
Part Number	06161100	06161800	06161200	06161300	06161400	06161500	06161600	06161700
Calibration	External	External	External	External	External	External	External	External
Capacity	6kg	15kg	15kg	30kg	60kg	150kg	60kg	150kg
Resolution NMI Approved	2g	5g	5g	10g	20g	50g	20g	50g
Adjustable Resolution	0.5g/1g/2g	1g/2g/5g	1g/2g/5g	2g/5g/10g	5g/10g/20g	10g/20g/50g	5g/10g/20g	10g/20g/50g
Dimensions	250(W)x480(D)x354(H)			300(W)x601(D)x723(H) mm			390(W)x751(D)x723(H)	
Pan Size	250mm x 250mm		300mm x 380mm			390mm x 530mm		
Serial Cable	Wire connection for terminal to DB9 Female (03000004)							
Power Supply	AC Mains (included) or rechargeable batteries (included)							

*NMI Versions also require trade verification - fees apply

Accessories	Part Number	Price (ex GST)
SW OP-03 RS-232C serial interface	06162001	\$375
SW OP-04 RS422/485 interface	06162002	\$375
SW OP-11 Bench/Wall bracket	06162004	\$215
Rechargeable Battery	ECEB-6V-YUASA	\$40

FS-Ki Series

Checkweighing IP65 Scales



**Ultra fast weighing response
Just 0.5 seconds!**

Trade Approval
NMI #6/4C/250

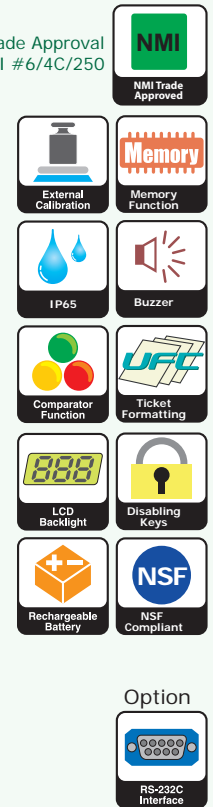

- Auto tare function
- Analog sweep display - 3 modes
- Memory for 99 products
- Large LCD display with backlight
- Rechargeable battery pack
- Numeric keypad for easy programming
- IP65 Dust and Waterproof
- Large comparator lights & Buzzer
- Comparator function with LO, HI or OK

Specifications	FS-6Ki	FS-15Ki	FS-15Ki-L	FS-30Ki
Price (ex GST)	\$1,565	\$1,565	\$1,780	\$1,780
Part Number	03078000	03078010	03078030	03078020
Calibration	External	External	External	External
Capacity	6kg	15kg	15kg	30kg
Resolution NMI Approved	0.002kg	0.005kg	0.005kg	0.01kg
Adjustable Resolution	0.5g/1g/2g	1g/2g/5g	1g/2g/5g	2g/5g/10g
Dimensions	250(W)x414(D)x496(H)mm		380(W)x464(D)x496(H)mm	
Pan Size	250mm x 250mm		380mm x 300mm	
Serial Cable	DIN Male to DB9 Female (03000002)			
Power Supply	AC Mains (included) or rechargeable battery (included)			

*NMI Versions also require trade verification - fees apply

Accessories	Part Number	Price (ex GST)
FS OP-03i RS232 + Relay Output	03078001	\$265
FS OP-04i RS422/485 + Relay Output	03078002	\$320
Rechargeable Battery	ECEB-6V	\$20
Protective Plastic Cover (pack of 5)	AX-FXI-31	\$105



Baseworks

HV-WP Base, SB Base, SC Base, SW Base



Trade Approval
NMI #6/9C/250A

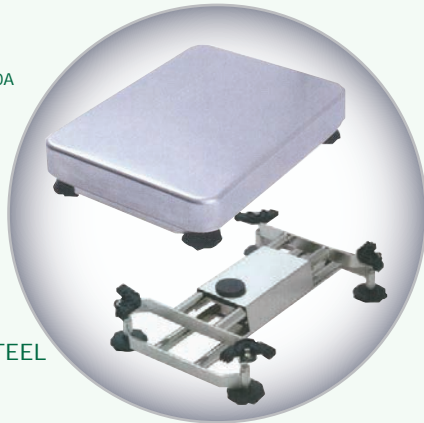

HV-WP IP65
STAINLESS STEEL

- Stainless steel one piece pan with round corners
- Aluminium single point waterproofed loadcell
- Built to withstand the rigours of industrial usage
- Can be used with any of A&D's digital indicators

Specifications	HV-30KB2WP	HV-60KB1WP	HV-150KB1WP
Price (ex GST)	\$1,080	\$1,080	\$1,080
Part Number	03122500	03122700	03122900
Capacity	30kg	60kg	150kg
Pan Size	326mm x 420mm	390mm x 530mm	390mm x 530mm

*NMI Versions also require trade verification - fees apply



Trade Approval
NMI #6/9C/291

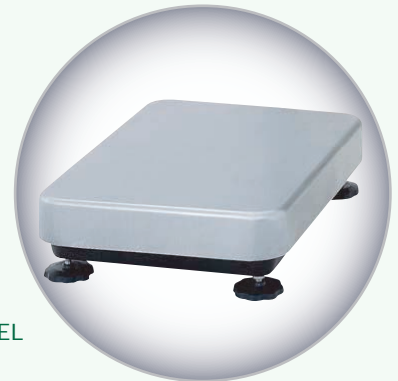

SB IP65
PAINTED MILD STEEL

- Can be connected to any of the A&D digital indicators
- Trade approved by NMI Australia
- Stainless steel pan
- Enclosed Aluminium loadcell for IP-65 protection
- Built to withstand the rigours of industrial usage

Specifications	SB-15K10-D	SB-60K11-D	SB-100K12-D	SB-200K12-D
Price (ex GST)	\$535	\$590	\$645	\$645
Part Number	03132203D	03132303D	03132403D	03132503D
Capacity	15kg	60kg	100kg	220kg
Pan Size	250mm x 250mm	330mm x 424mm	390mm x 530mm	

*NMI Versions also require trade verification - fees apply



Trade Approval
NMI #6/4C/276

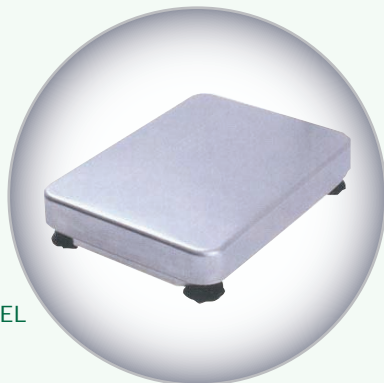

SC IP68
STAINLESS STEEL

- Stainless Steel baseworks with IP-68 rating
- Can be used with any of A&D's digital indicators
- Epoxy coated Aluminium loadcell
- Built to withstand the rigours of industrial usage

Specifications	SC-30BM	SC-60BL	SC-150BL
Price (ex GST)	\$750	\$855	\$965
Part Number	06160850	06160650	06160750
Capacity	30kg	60kg	150kg
Pan Size	300mm x 380mm	390mm x 530mm	390mm x 530mm

*NMI Versions also require trade verification - fees apply



Trade Approval
NMI #6/4C/274

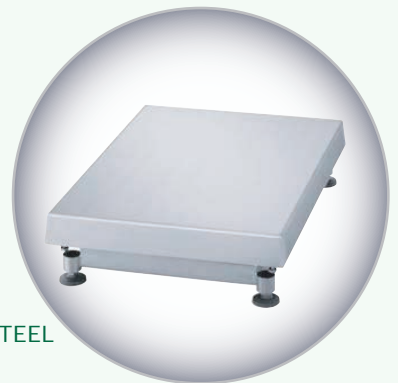

SW IP69K
STAINLESS STEEL

- Premium resistance to hostile environments
- Can be connected to any of the A&D digital indicators
- Trade approved by NMI Australia
- Built to withstand the rigours of industrial usage
- Stainless Steel loadcell

Specifications	SW-60KBM	SW-150KBM	SW-60KBL	SW-150KBL
Price (ex GST)	\$1,620	\$1,620	\$2,160	\$2,160
Part Number	06162200	06162300	06162400	06162500
Capacity	60kg	150kg	60kg	150kg
Pan Size	300mm x 380mm		390mm x 530mm	

*NMI Versions also require trade verification - fees apply

AD-300 & AD-600 Series

Accurate Platform Scales

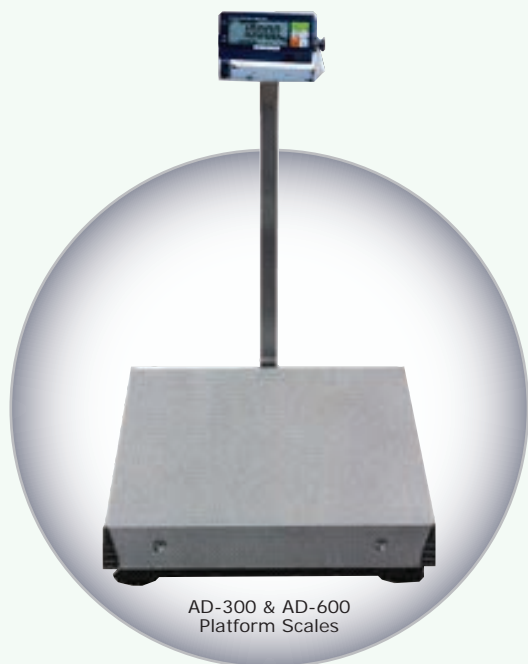

AD-300 & AD-600
Platform Scales

Trade Approval
NMI #6/9C/250A
(AD300KA4 only)



Option



- Large capacity stainless steel platform
- Low profile design allows for easy access

Specifications	AD-300KA4	AD-600KA4
Price (ex GST)	\$2,915	\$2,915
Part Number	03113600	03113500
Calibration	External	External
Capacity	300kg	600kg
Resolution	0.1kg	0.1kg
Pan Size	600mm x 700mm	600mm x 700mm
Product NMI	Trade Approved	Not Approved

*NMI Versions also require trade verification - fees apply

SD-200

Warehouse Trolley Scales



- High Weighing capacity (200kg maximum)
- Fully Portable and easy to maneuver
- Sturdy construction and high stability
- Battery operated indicator

Specifications	SD-200
Price (ex GST)	\$1,725
Part Number	06163000
Capacity	200kg
Resolution	0.5kg
Dimensions	900(W) x 600(D) x 900(H) mm
Platform Size	900mm x 600mm
Power Supply	6 x C size batteries included



ELP-1200 Series

Low Profile Pallet Scales for Dry Areas



Trade Approval
NMI #6/9C/220B

Indicator



Option



Supplied uncalibrated



ELP-1200
1200kg Weighing in dry areas

- Full SUS430 Stainless Steel Loadcells
- Low profile design allows for easy access
- Loadcell cable 5m
- Painted steel platform ideal for dry areas

Specifications	ELP-1200 Base Only
Price (ex GST)	\$1,080
Part Number	03010105 BASE ONLY (PAINTED)
Price (ex GST)	N/A
Part Number	N/A
Capacity	1200kg x 0.5kg
Construction	Mild Steel
Material Finish	Painted
Platform Dims	1200mm x 1200mm
Platform Fixing	Welded to base frame
Weight of scale	Approx. 95kg
Load cells	4 x ADALC1-T1 SB
Application Area	Lighter Capacity in Dry Areas
Application	Not suitable for pit mount
Base Height	100mm to 120mm
Corner Adjustment	Side mounted junction box

*NMI Versions also require trade verification - fees apply
Pallet Scales can be set to 600kg x 0.2kg but this option is NOT NMI Approved

Accessories	Part Number	Price (exGST)
ELP-1200 & AD4406 (Trade Approved) Combo	03010105 & 06138600	\$1,510
Levelling leg (old style) Dia = 35mm	MC07019.000	\$45
Levelling leg (swivel style) Dia = 58mm	MC07032.000	\$45
OP-12 Stainless steel wall bracket	03176100	\$50
Cast loadcell 7 pin plug for indicator (has holes)	EAJM-NJC207-PF	\$60
Cast loadcell 7 pin socket for basework (has pins)	EAJM-NJC207-RM	\$60

*NMI Versions also require trade verification - fees apply

A&D 3000 Series

Low Profile Pallet Scales

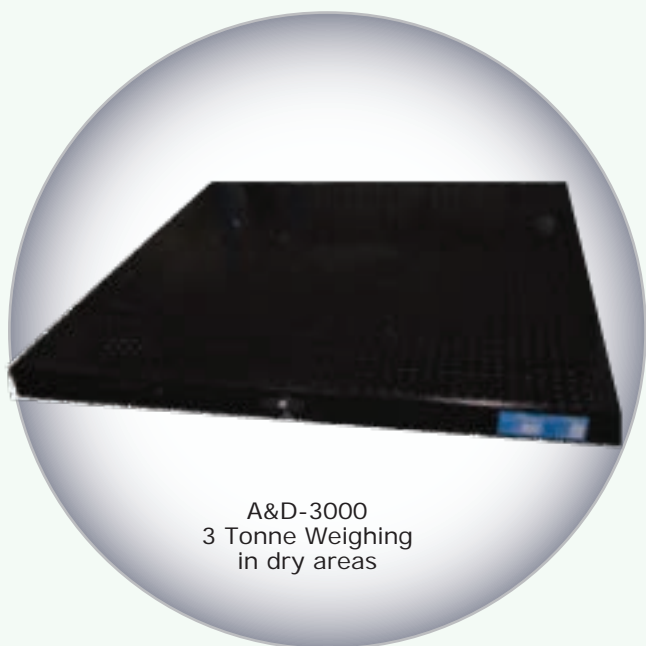

A&D-3000
3 Tonne Weighing
in dry areas

Trade Approval
NMI #6/9C/220B



Supplied uncalibrated

- Approved for Trade Use
- Low profile design allows for easy access
- High Strength in Dry Areas
- Loadcell cable 5m



AD-4406 Indicator
(bracket is not included as standard)

Indicator



Option



Specifications	A&D-3000 Base Only
Price (ex GST)	\$1,510
Part Number	03010102
Capacity	3000kg x 1kg or 1500kg x 0.5kg
Construction	Mild Steel
Material Finish	Painted
Platform Dims	1200mm x 1200mm
Platform Fixing	Welded to base frame
Weight of scale	Approx. 110kg
Load cells	4 x LCM13-T001 SUS430
Application Area	High Strength in Dry Areas
Application	Suitable for pit mount
Base Height	140mm to 155mm
Corner Adjustment	In-line cable summing unit

*NMI Versions also require trade verification - fees apply
Pallet Scales can be set to 600kg x 0.2kg but this option is NOT NMI Approved

Accessories	Part Number	Price (ex GST)
A&D-3000 & AD4406 (Trade Approved) Combo	03010102 & 06138600	\$1,945
Levelling leg (old style) Dia = 35mm	MC07019.000	\$45
Levelling leg (swivel style) Dia = 58mm	MC07032.000	\$45
A&D3000 summing unit 5m cable (no plate)	EMKO-11910	\$125
OP-12 Stainless steel wall bracket	03176100	\$50
In ground mounting kit	03010202	\$100
In ground pit surround 1200mm x 1200mm	03011200	\$430
Cast loadcell 7 pin plug for indicator (has holes)	EAJM-NJC207-PF	\$60
Cast loadcell 7 pin socket for basework (has pins)	EAJM-NJC207-RM	\$60

*NMI Versions also require trade verification - fees apply



ELP Series

Low Profile Pallet Scales for Wet & Dry Areas

Pallet Scales



Trade Approval
NMI #6/9C/220B



Indicators



(AD-4407)



Option

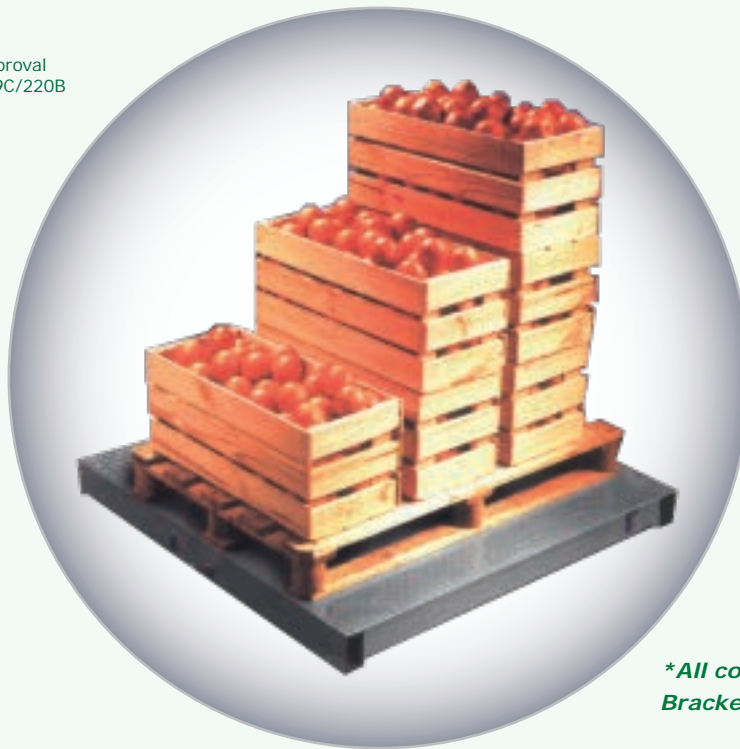

Base & Indicator Combo*
AD-4407 or AD-4406

**All combinations supplied uncalibrated
Bracket not included on AD-4406*

- Painted steel platform ideal for dry areas
- Low profile design allows for easy access
- Suitable for use with all A&D indicators
- Full SUS430 Stainless Steel Loadcells
- Low profile design allows for easy access
- Suitable for use with all A&D indicators
- Loadcell cable 5m

Specifications

ELP-3000 Base Only

Price (ex GST)	\$6,485
Part Number	03010203 BASE ONLY (SUS430 Stainless Steel)
Price (ex GST)	\$2,590
Part Number	03010201 BASE ONLY (GALVANISED)
Capacity	3000kg x 1kg or 1500 x 0.5kg
Construction	Mild Steel
Material Finish	Galvanised
Platform Dims	1200mm x 1200mm
Platform Fixing	Screwed to base frame
Weight of scale	Approx. 115kg
Load cells	4 x LCM13-T001 SUS430
Platform Dims	Hostile Wet Areas
Application	Suitable for pit mount
Base Height	140mm to 155mm
Corner Adjustment	In-line cable summing unit

*NMI Versions also require trade verification - fees apply
Pallet Scales can be set to 600kg x 0.2kg but this option is NOT NMI Approved

Accessories	Part Number	Price (exGST)
ELP-3000 & AD4406 (Trade Approved, Galvanised) Combo	03010201 & 06138600	\$3,025
ELP-3000 & AD4407 (Trade Approved, Galvanised) Combo	03010201 & 06138700	\$3,240
Levelling leg (old style) Dia = 35mm	MC07019.000	\$45
Levelling leg (swivel style) Dia = 58mm	MC07032.000	\$45
ELP3000 summing unit 5m cable with cover plate	EMKO-11909	\$125
OP-12 Stainless Steel wall bracket for AD-4406	03176100	\$50
In ground mounting kit	03010202	\$100
In ground pit surround 1200mm x 1200mm	03011200	\$430
Cast loadcell 7 pin plug for indicator (has holes)	EAJM-NJC207-PF	\$60
Cast loadcell 7 pin socket for basework (has pins)	EAJM-NJC207-RM	\$60

*NMI Versions also require trade verification - fees apply

Weighbeams

Quality Stainless Steel Construction



Weighbeams

Trade Approval
NMI #6/9C/220B



(AD-4407)



Weighbeam AD4406
Combo

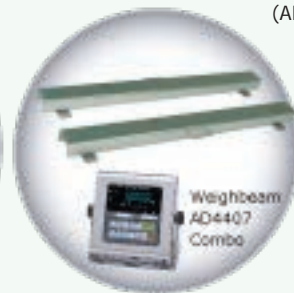

Weighbeam
AD4407
Combo

- Quality 304 grade stainless steel construction
- Highly portable with carry handle
- Beams formed from 5mm thickness material for greater strength
- Will interface with A&D indicators
- 1200mm (l) x 100mm (w) x 80mm (h)
- Capacity: 2000kg per set of 2 beams
- Connection cable 5m from beams to indicator
- AD4406 has battery or AC operation, AD4407 has AC only
- Should be fixed width between beams for trade approval status

Specifications	Weighbeams only
Price (ex GST)	\$2,695
Part Number	03181000
Capacity	2000kg
Dimensions	1200(L) x 100(W) x 80(H) mm

*NMI Versions also require trade verification - fees apply

Accessories	Part Number	Price (ex GST)
A&D Weighbeam & AD4406 indicator combo	03181000 & 06138600	\$2,975
A&D Weighbeam & AD4407 indicator combo	03181000 & 06138700	\$3,495

Ask us if you require alternative capacities!



OHT combinations are supplied uncalibrated

OHT Series

Overhead Track Scales



Trade Approval
NMI #6/18/17B



- Quality galvanised finish
- Also available as 300kg x 0.1kg (Trade Approved)
- Waterproof track scale suitable for wet environments
- Choice of indicators to suit various applications
- Choice of optional bracket lengths
- Weigh rail thickness: 12mm
- Can ONLY be Trade Verified AFTER installation
- Centre and End load compensation feature for accurate weighing

Specifications	OHT 300mm	OHT 600mm	OHT 1200mm
Price (ex GST)	\$2,895	\$2,895	\$2,895
Part Number	03020101	03020102	03020103
Capacity	600kg	600kg	600kg
Resolution	0.2kg	0.2kg	0.2kg
Weigh rail	300mm	600mm	1200mm

*NMI Versions also require trade verification - fees apply

IMPORTANT NOTE: OHT pre-despatch set up cost is \$140.00

Accessories	Part Number	Price (ex GST)
OHT 300/600/1200mm rail & AD4407 combo	03020101/2/3 & 06138700	\$3,495
OHT OP-01 125mm brackets (pair)	03022001	\$345
OHT OP-02 250mm brackets (pair)	03022002	\$345



AD-4401 / AD-4402 / AD-4404

AD Batching Indicators



- High performance weighing / batching indicator
- High speed A/D convertor - 100 per second, High display resolution up to 1 in 16000
- High Internal A/D resolution of up to 1,000,000 counts
- Monitor & Control weighing & Batching using displayed or internal counts
- Fuzzy logic or standard Automatic Free Fall Compensation for consistent results
- Automatic weight or count accumulation



Specifications	AD-4401
Price (ex GST)	\$1,835
Part Number	06138300
Power	AC Mains
Dimensions	144(W) x 197(D) x 72(H) mm

*NMI Versions also require trade verification - fees apply



AD-4401 INDICATOR

Accessories	Part Number	Price (ex GST)
OP-01 BCD output	06138301	\$460
OP-03 RS422/RS485 interface	06138303	\$460
OP-04 RS232C + current loop serial	06138304	\$460
OP-07 analog output	06138307	\$590



- Multi function from batch weighing to field bus networking applications
- Main display has 7-digit VFD with 18mm high characters
- Sub display has 108 x 5mm high characters to show values and comments
- Pre-programmed with multiple sequences and functions for filling machines and simple mixing
- Stores 100 data for raw materials and 100 data for recipes



Specifications	AD-4402
Price (ex GST)	\$2,915
Part Number	06138400
Power	AC Mains
Dimensions	192(W) x 135(D) x 96(H) mm

*NMI Versions also require trade verification - fees apply



AD-4402 INDICATOR

Accessories	Part Number	Price (ex GST)
OP-01 Parallel BCD Output	06138401	\$710
OP-02 Relay Output	06138402	\$710
OP-03 RS422/RS485 interface	06138403	\$710
OP-04 RS232C + current loop serial	06138404	\$710
OP-05 Parallel I/O	06138405	\$710
OP-07 Analogue Output	06138407	\$810
OP-20 CC-Link Interface	06138420	\$1,220
OP-21 DeviceNet Interface	06138421	\$1,725
OP-22 PROFIBUS interface	06138422	\$2,160



- High performance advanced checkweighing indicator
- Up to 100 sets of target (OK weight), Hi, Lo and tare can be stored by code number
- Twin displays show weight and operational details
- Sealed keys keep out dust in industrial environments IP65 grade
- User programmable check-weighing modes to meet many specific requirements



Specifications	AD-4404
Price (ex GST)	\$2,915
Part Number	06139200
Power	AC Mains
Dimensions	192(W) x 135(D) x 96(H) mm

*NMI Versions also require trade verification - fees apply



AD-4404 INDICATOR

Accessories	Part Number	Price (ex GST)
OP-21 DeviceNet Interface	06139221	\$1,725

Other AD-4404 Options: See AD-4402 Options

AD-4405 / AD-4406 / AD-4407

AD Indicators



- Ten keys for preset tare and units weighing setting etc
- Accumulative data can be stored into memory automatically or manually
- Comparator Function Upper/Lower, HiHi/Hi/OK/Lo/Lolo & comparison
- Optional Dot Matrix Printer
- 2 weighing ranges selectable

Specifications	AD-4405
Price (ex GST)	\$1,100
Part Number	06138500
Power	AC Mains
Dimensions	275(W) x 159(D) x 111(H) mm

*NMI Versions also require trade verification - fees apply



AD-4405 INDICATOR

NMI #S451



Accessories	Part Number	Price (ex GST)
OP-03 RS422/RS485 interface*	06138503	\$395
OP-05 RS232C + relay output*	06138505	\$395
OP-06 Dot Matrix Printer	06138506	\$745
OP-07 4-20mA Analog output	06138507	\$395

*Only one of these can be installed/fitted

- Alkaline C type battery: battery life 180 hours (LC 350ohms x 1); battery life 70 hours (LC 350ohms x 4)
- Accumulative data can be stored into memory automatically or manually
- Automatic batching and customer programming capability
- F1, F2 selectable function keys
- Optional stand/bracket available

Specifications	AD-4406
Price (ex GST)	\$535
Part Number	06138600
Power	TB-200 (included) C size battery (not included)
Dimensions	192(W) x 87(D) x 96(H) mm

*NMI Versions also require trade verification - fees apply



AD-4406 INDICATOR

NMI #S503

IN PANEL



Accessories	Part Number	Price (ex GST)
OP-03 RS422/RS485*	06138603	\$430
OP-04 programmable RS232C*	06138604	\$160
OP-05 RS232 & relay output*	06138605	\$430
OP-07 4-20mA analog output*	06138607	\$535
OP-12 stainless steel bracket (wall/desk)	03176100	\$50

*Only one of these can be installed/fitted

- Ideal for dust and waterproof weighing applications with IP65 grading
- Bracket comes as standard
- NMI Trade approved scale
- Automatic batching and customer programming capability
- Counting function

Specifications	AD-4407
Price (ex GST)	\$970
Part Number	06138700
Power	AC Mains
Dimensions	199(W) x 80(D) x 206(H) mm

*NMI Versions also require trade verification - fees apply



AD-4407 INDICATOR

NMI #S503



Accessories	Part Number	Price (ex GST)
OP-03 RS422/RS485*	06138703	\$485
OP-05 RS232 & relay output*	06138705	\$485
OP-07 4-20mA analog output*	06138707	\$710

*Only one of these can be installed/fitted



AD-4328 / AD-4329

Basic Weighing Indicators

- NMI #5387
- IP65
- IN PANEL (AD4328)
- RS-232C Interface (AD4329)
- LED Display
- Accumulation Function
- Comparator Function
- Counting Function

- The AD-4328 satisfies all the basic weighing requirements for platform, packer, hopper scales
- The AD-4329 has triple range for scales with multiple weighing intervals
- The AD-4329 comes with RS-232 relay output as standard
- Check weighing mode (3 levels) to compare weighing data
- Set point comparison for batching applications
- Accumulated data can be manually or automatically stored in the memory

Specifications	AD-4328	AD-4329
Price (ex GST)	\$970	\$860
Part Number	06138100	06139100
Power	TB-200	AC Mains
Dimensions	170(W) x 145(D) x 130(H)mm	192(W) x 165(D) x 96(H) mm

*NMI Versions also require trade verification - fees apply

Accessories	Part Number	Price (ex GST)
AD-4328 OP-01 BCD output	06138001	\$375
AD-4328 Comparator output	06138002	\$375
AD-4328 OP-05 RS422C/485 interface	06138003	\$375
AD-4328 OP-07 RS232C + current loop	06138004	\$375
AD-4329 Comparator relay output	06139002	\$375

AD-4328



AD-4329



FSi-D / SW-D

Waterproof Indicator with Rapid Stabilisation

- IP65
- RS-232C Interface
- VFD Display
- Accumulation Function
- Comparator Function
- Counting Function

The FS-D, which comes with a desktop/wall-mount stand and a connector plug, can even be used with platforms scales other than A&D's. The eight preset capacities range from 6 kg (15 lb) to 1,500 kg (3,500 lb) and the three resolutions from 1/3,000 to 1/12,000 (or 1/15,000) (NB: only one of each can be selected at a time).

Specifications	FSi-D DISPLAY
Price (ex GST)	\$1,295
Part Number	06132500
Power	AC Mains Rechargeable battery (included)
Bracket	Included
Dimensions	250(W) x 130(D) x 150(H) mm



FSi-D IP65 INDICATOR

Accessories	Part Number	Price (ex GST)
OP-03 RS232 & relay output	03078001	\$265
OP-04 RS422 / 485 + relay output	03078002	\$320
Rechargeable battery	ECEB-6V	\$20

- IP69K
- RS-232C Interface
- LED Display
- Accumulation Function
- Comparator Function
- Counting Function

The SW display unit (SW-D) is as an IP69K indicator with touch sensitive capacitive keys to ensure permanent waterproofing in damp/wet environments. The SW indicator has 5 step comparator lights and can also be used with platform scales other than A&D's.

Specifications	SW-D DISPLAY
Price (ex GST)	\$1,295
Part Number	06132500
Power	AC Mains Rechargeable battery (included)
Bracket	Not Included
Dimensions	255(W) x 134(D) x 178(H) mm



SW-D IP69K INDICATOR

Accessories	Part Number	Price (ex GST)
OP-03 RS232C serial interface	06162001	\$375
OP-04 RS422 / 485 interface	06162002	\$375
OP-11 Bench/Wall bracket	06162004	\$215
Rechargeable battery	ECEB-6V-YUASA	\$40

AD-4408 / AD4410 / AD-4532B / AD4430B

AD Process Indicators



- High performance digital filtering that eliminates strong vibration (especially AD-4410)
- Various types of field network (fieldbus) modules can be installed (AD-4408)
- Compact, lightweight body makes it ideal for mounting into a control panel
- Dust and waterproof display (when mounted into a panel)
- Highly tolerant against electromagnetic noise

Specifications	AD-4408A*	AD-4410*
Price (ex GST)	\$1,945	\$1,945
Part Number	06148000	06134500
Power	AC Mains	AC Mains
Dimensions	144(W) x 135(D) x 72(H) mm	144(W) x 110(D) x 72(H) mm

*Anybus option available: check brochure for details

AD-4408



- IN PANEL
- IP65
- AD4410
- RS-232C Interface
- AD4410
- Comparator Function
- LED Display

AD-4410



- High Speed Weighing- 2000 updates per second
- Wide Variety of Standard Data I/O- Analog Amplifier Voltage Output (+/-10v), D/A Analog Voltage Output (+/-10v), Comparator Output and a Modbus RTU I/O
- 5 Level Comparator- Multi level settings for a multi level test procedure
- Displayed Upper and Lower Setting-Immediate recall of test parameters
- 4 Different Hold Functions-Select from Peak, Bottom, Sample, Bipolar Hold

Specifications	AD-4532B
Price (ex GST)	\$1,620
Part Number	06230700
Power	AC Mains
Dimensions	96(W) x 168(D) x 96(H) mm

AD-4532B INDICATOR



- IN PANEL
- IP65
- LED Display
- Accumulation Function
- Comparator Function
- Counting Function

Accessories	Part Number	Price (ex GST)
OP-01 BCD Output (40 pin FCN connector)	06230504	\$320
OP-04 RS232C (D-Sub 9 pin)	06230505	\$320
OP-07 D/A Analog Volt/Current Output (+/-10V)	06230503	\$430
OP-08 Ethernet interface (RJ-45)	06230506	\$755

- DIN rail mounted type ideal for insertion into control board
- Powerful vibration-cancelling function (High Performance Digital Filter)
- High speed sampling (1000 times per second) - High accuracy
- BCD input/output a standard feature (up to 1000 times/sec high speed output)
- Equipped with powerful noise suppression circuit
- Accurate linear correction function using high-order equations

Specifications	AD-4430B
Price (ex GST)	\$970
Part Number	06149000
Power	AC Mains
Dimensions	36(W) x 110(D) x 101(H) mm

AD-4430B DIN RAIL INDICATOR



- LED Display
- Comparator Function

AD-4541-V/I

Ultra Slim Analog Signal Conditioner



- Ultra-slim, lightweight and easy-to-install
- Calibration can be performed with the ZERO / SPAN volume controls or the CAL switch
- Wide-range zero adjustment ($\pm 1.6\text{mV/V}$) / span adjustment (0.4~3.2mV/V) for use with various bridge type sensors
- No crimping terminal is necessary because a spring clamp terminal block is used for easy wiring.

Specifications	AD-4541-I	AD-4541-V
Price (ex GST)	\$535	\$535
Part Number	06134200	06134300
Output	4mA to 20mA	-2V to +2V
Power	AC Mains	
Dimensions	45(W) x 122(D) x 24(H) mm	

AD-4541-V/I SIGNAL CONDITIONERS





SF-KA / SF-KB Series

30 Slot Look-up Retail Scales



Trade Approval
NMI #6/4D/291



- **Trade Approved by NMI Australia**
- Dual range operation for maximum accuracy
- SFB Series has a Tower, LC Display and dry batteries or mains power
- SFA Series has a Tower, VF Display and mains only power
- Stainless steel pan is ideal for easy cleaning
- Choice of Display & Power source
- 30 slot Price Look Up memory



Specifications	SF-6KA	SF-15KA	SF-30KA	SF-6KB	SF-15KB	SF-30KB
Price (ex GST)	\$710	\$710	\$710	\$600	\$600	\$600
Part Number	06307000	06307500	06307100	06307200	06307600	06307900
Calibration	External	External	External	External	External	External
Capacity	3kg / 6kg	6kg / 15kg	15kg / 30kg	3kg / 6kg	6kg / 15kg	15kg / 30kg
Resolution	1g / 2g	2g / 5g	5g / 10g	1g / 2g	2g / 5g	5g / 10g
Display	Vacuum fluorescent display for poorly lit areas			Liquid crystal display		
Dimensions	465(W) x 425(D) x 460(H) mm			465(W) x 425(D) x 460(H) mm		
Pan Size	300mm x 280mm			300mm x 280mm		
Power Supply	AC Adaptor TB-S200 (included)			AC TB-S200 (included) or 6 x D batteries (not included)		



SG Series

12 Slot Look-up Retail Scales



Trade Approval
NMI #6/4D/291



- **Trade Approved by NMI Australia**
- Dual range operation for maximum accuracy
- Stainless steel pan is ideal for easy cleaning
- SG model easily sits on table/bench top
- 12 slot Price Look Up memory



Specifications	SG-6KA	SG-15KA	SG-30KA
Price (ex GST)	\$600	\$600	\$600
Part Number	06308100	06308200	06308300
Capacity	3kg / 6kg	6kg / 15kg	15kg / 30kg
Resolution	1g / 2g	2g / 5g	5g / 10g
Calibration	External		
Display	Liquid crystal display		
Dimensions	330(W) x 425(D) x 108(H) mm		
Pan Size	300mm x 280mm		
Power Supply	AC Adaptor TB-S200 or 6 x D size batteries		

HC-i Series Precision Counting Scales



Detachable display



Internal rechargeable battery pack



Optional traffic light



Simple operation and easy to read display

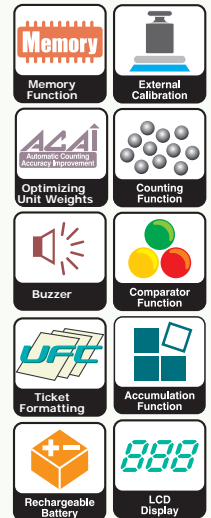

Options

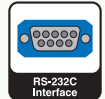

- 3 methods to initialize unit weights: sample, memory, and keyboard input
- Large memory for 99 products incl. Tare, Unit weight and Comparator limits
- Navigation system with LEDs indicating active keys for easy and faster operation
- Automatic counting accuracy improvement (ACAI)
- Comparator with HI (exceeding), OK, and LO (insufficient) results
- Accumulation function totals piece count into memory
- High internal resolution 1/600 000 or 1/750 000 & Ability to count small objects down to 0.005g
- Beeping function with frequency variation as you approach your preset target
- UFC: easy formatting of your RS-232C outputs and labels for printers

Specifications	HC-3Ki	HC-6Ki	HC-15Ki	HC-30Ki
Price (ex GST)	\$485	\$485	\$485	\$485
Part Number	06012600	06012700	06012800	06012900
Calibration	External	External	External	External
Capacity	3kg	6kg	15kg	30kg
Resolution	0.5g	1g	2g	5g
Min Piece Weight (fine)	0.005g	0.01g	0.02g	0.05g
Dimensions	315(W) x 331(D) x 126(H) mm			
Pan Size	300mm x 210mm			
Serial Cable	DB25 Male to DB9 Female (03000001)			
Power Supply	AC Adaptor TB-S200 or rechargeable battery included			

Accessories	Part Number	Price (ex GST)
HCi OP-03 RS232C Serial Data Interface	06012003	\$180
HCi OP-04 RS232C + Relay Output	06012004	\$235
HCi OP-08 Extension Cable (2m)	06012008	\$105
Rechargeable Battery Option	ECEB-6V	\$20



FC-i / FC-Si Series

High Performance Counting Scales

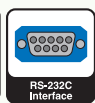

Simple operation and easy to read Vacuum Fluorescent Display



FC-5000i

Options



- High internal resolution: 1/10 000 000(FC-Si) and 1/1 000 000(FC-i)
- Up to 3 RS-232C ports
- FC-Si models come with SHS sensor
- 4 methods to initialize the unit weight: sample, memory, keyboard input, and bar code reading
- Automatic counting accuracy improvement (ACAI)
- Comparator with HI (exceeding), OK, and LO (insufficient) results
- Accumulation function totals piece count into memory
- Remote platform option offers bulk counting
- Large memory for up to 500 IDs (ID, unit weight, tare, comparator limit)
- Navigation system with LEDs indicating active keys for faster operation



FC-Si with optional traffic light and optional comparator relay interface

Specifications	FC-500Si ■	FC-5000Si ■	FC-5000i	FC-10Ki	FC-20Ki	FC-50Ki
Price (ex GST)	\$2,700	\$2,700	\$2,270	\$2,270	\$2,270	\$2,270
Part Number	06020100	06020200	06020400	06020500	06020600	06020700
Calibration	External	External	External	External	External	External
Capacity	500g	5kg	5kg	10kg	20kg	50kg
Resolution	0.02g	0.2g	0.5g	1g	2g	5g
Min Piece Weight (fine)	0.00005g	0.0005g	0.005g	0.01g	0.02g	0.05g
Dimensions	330(W) x 462(D) x 106(H)mm		330(W) x 462(D) x 117(H) mm			
Pan Size	128x128mm	165x165mm	300mm x 280mm			
Serial Cable	DB9 Male to DB9 Female (03000007)					
Power Supply	AC Adaptor TB-S139 (included)					

● ex Japan

Accessories	Part Number	Price (ex GST)
FCi OP-01 Barcode Reader	06020105	\$535
FCi OP-03 Dual Channel RS232C	06020101	\$600
FCi OP-04 RS232C & Comp/Relay Output	06020102	\$600
FCi OP-05 Remote Scale Connector	06020103	\$430
FCi OP-02 NiMH Battery Pack (10 hours)	06020104	\$860
Serial Cable - DB9 Female to DB9 Female	03000007	\$60

AP-30i

Postal Counter Scales



Trade Approval
NMI #6/4C/210

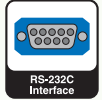

Dual displays on both ends.
The operator and customer can
easily see the weight measurements

2000g x 1g
30kg x 10g



Australia Post Preferred
Interfaces directly with the
Australia Post EPOS System



- Designed for and used by Australian & New Zealand Post Offices
- Maximum accuracy when weighing letters and parcels
- Dual range operation with dual Liquid Crystal Displays (LCD) for the operator and customer
- Triple data outlets: Weight transfer to up to 2 EPOS stations and 1 remote display
- *Fully trade approved by NMI Australia & Australia Post*
- When the weight is stable the data is automatically sent to the EPOS station
- Low profile and small footprint means minimal bench space taken
- Stainless steel weighing pan
- AC Mains or battery power

Specifications	AP-30i POSTAL SCALE
Price (ex GST)	\$1,840
Part Number	03079911
Product Description	Postal Scale with dual range automatic switching
Capacity	2000g / 30kg
Resolution	1g / 10g
Dimensions	325(W) x 483 (D) x 94(H) mm
Pan Size	300 mm x 280 mm
Serial Cable	N/A
Power Supply	AC Adaptor TB-S200 (included) or battery (not included)

AD-4961-2KD

EZI-CHECK™ Intelligent Checkweighers

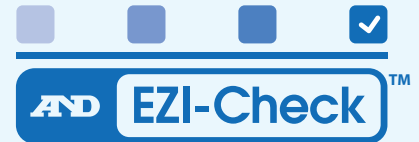

- Full colour touch screen LCD
- Up to 320 packs per minute
- Up to 1000 product IDs with images
 - Save data/graphs direct to USB memory sticks
 - A&D's original, automatic adjustment function enables easy product parameter settings or adjustments
 - High speed, Digital Signal Processing (DSP)
 - Dual range model. The checkweigher's weighing range and resolution can be selected from 500g x 0.01g or 2000g x 0.1g
 - Meets the requirements of hygienic food processing
 - Stainless steel frame construction meets IP65 requirements
 - Easy switch to another production batch with minimal downtime
 - "Flat pack" ease of transport and setup
 - Full interaction via MODBUS ethernet comms



Specifications	AD-4961-500D	AD-4961-2KD
Capacity	500g	2000g
Resolution	0.01g	0.1g
Repeatability 3σ	±0.08g	±0.18g
Max weighing speed	320 pieces / min	
Max belt speed	15-120m/min Urethane belt	
Belt Size	200(W) x 350(L) mm	
Max. product dimensions	200mm (W), 30-300mm (L)	
Display	7inch colour LCD Touch Panel	
Recorded items	1000 items (10 groups x 100 items)	
Sealed USB port (IP-65)	USB 2.0 (memory & upload)	
Serial interface	RS232C or RS485 available	
Ethernet	10 Base-T/100Base-T Auto-MDIX	
Modbus	Modbus RTU & TCP available	
Dimensions	660(W) x 700(L) x 710-860(H) mm	
Water/Dust resistance	IP65 Stainless Steel	
Power Supply	AC 100-240V With Emergency Function	

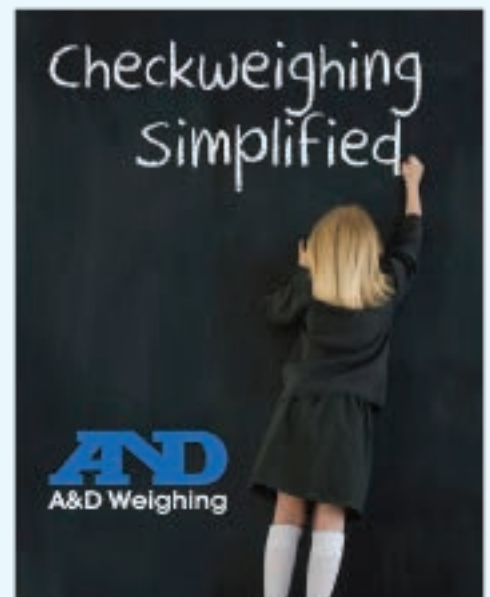

Model	Part Number	Price (ex GST)
EZI-Check INTELLIGENT In Line Checkweigher	03055000	POA
EZI-Check Drop Conveyor module	03055020	POA
EZI-Check Flipper/Diverter module	03055010	POA
EZI-Check Air Blast module	03055030	POA
EZI-Check Op-20 Leg extension feet set	03055082	POA
EZI-Check Op-01 Display column stand	03055070	POA
EZI-Check Op-02 Tower Lights	06138877	POA
EZI-Check Op-11 Breeze Break	03055074	POA
EZI-Check PLUS Data Capture and Reporting Software		POA
WinCT Plus Multi Scale Data Capture & Import Utility (LAN/Serial)		POA



AD-4961-6K

EZI-CHECK™ Intelligent Checkweighers



6kg Capacity Checkweigher with optional stand display and push rejector

- The AD-4961-6K weighing capacity is 6000g x 0.5g
- Full colour 7 inch panel touch screen LCD display
- Save data/graphs direct to USB memory sticks
- High speed, Digital Signal Processing (DSP)
- Meets the requirements of hygienic food processing
- Stainless steel frame construction meets IP65 requirements
- Up to 145 packs per minute
 - Up to 1000 product IDs with images
 - “Flat pack” ease of transport and setup
- Easy switch to another production batch with minimal downtime
- Full interaction via MODBUS ethernet comms

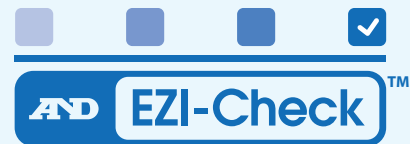

Bringing Innovation to Inspection!

Specifications	AD-4961-6K
Capacity	6000g
Resolution	0.5g
Repeatability 3σ	±1.5g
Max weighing speed	145 pieces / min
Max belt speed	15-120m/min Urethane belt
Belt Size	300(W) x 500(L) mm
Max. product dimensions	300mm (W), 80-450mm (L)
Display	7inch colour LCD Touch Panel
Recorded items	1000 items (10 groups x 100 items)
Sealed USB port (IP-65)	USB 2.0 (memory & upload)
Serial interface	RS232C or RS485 available
Ethernet	10 Base-T/100Base-T Auto-MDIX
Modbus	Modbus RTU & TCP available
CW Dimensions	736(W) x 1005(L) x 720-870(H) mm
Push Rejector Dims	945(W) x 502(L) x 850(H) mm
Water/Dust resistance	IP65 Stainless Steel
Power Supply	AC 100-240V with Emergency Function



Model	Part Number	Price (ex GST)
EZI-Check INTELLIGENT 6kg Capacity Checkweigher	03055800	POA
EZI-Check Push Rejector module	03055900	POA
EZI-Check Op-20 Leg extension feet set	03055082	POA
EZI-Check Op-01 Display column stand	03055070	POA
EZI-Check Op-02 Tower Lights	06138877	POA
EZI-Check Op-11 Breeze Break		POA

AD-4971

EZI-CHECK™ Intelligent Metal Detectors

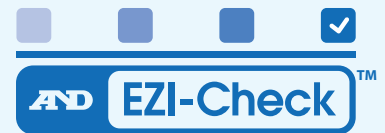

EZI-Check Metal Detector comes in three apertures: 100mm, 170mm & 250mm

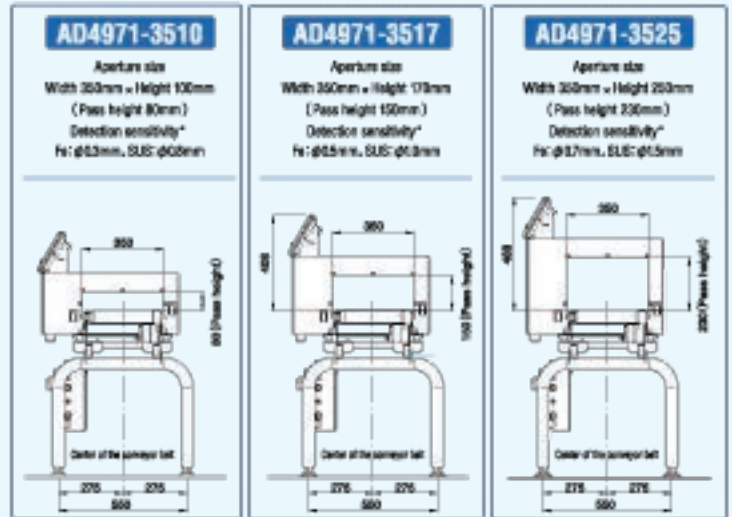

* Detection sensitivity will change depending on product and environmental conditions. Please prepare a φ6-7mm power cable.

Specifications	AD-4971
Max belt speed	10-60m/min Urethane belt
Belt Size	250(W) x 800(L) mm
Display	7inch colour LCD Touch Panel
Aperture width	350mm
Aperture height	100mm / 170mm / 250mm
Aperture pass height	80mm / 150mm / 230mm
Ethernet	10 Base-T/100Base-T Auto-MDIX
Modbus	Modbus RTU & TCP available
Dims (100mm)	625(W) x 800(L) x 1050~1200(H) mm
Dims (170mm)	625(W) x 800(L) x 1118~1268(H) mm
Dims (250mm)	625(W) x 800(L) x 1198~1348(H) mm
Water/Dust resistance	IP65 Stainless Steel
Power Supply	AC 100-240V With Emergency Function

Operations such as stopping and starting inspection, collecting data and changing product can all be set from an external device.

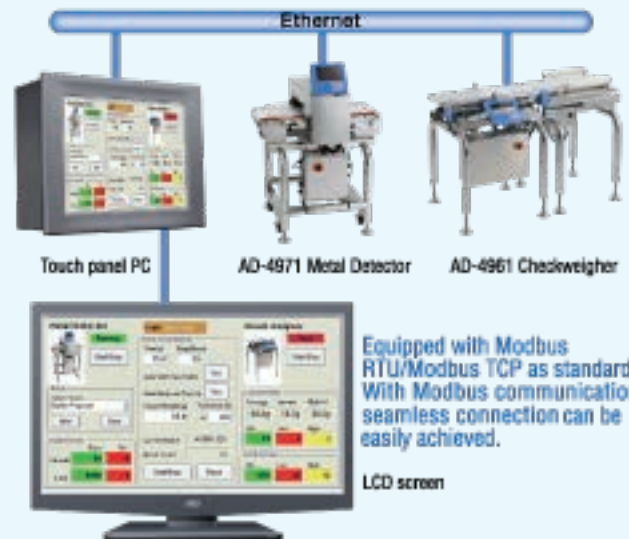

Equipped with Modbus RTU/Modbus TCP as standard. With Modbus communication seamless connection can be easily achieved.

LCD screen

Model	Part Number	Price (ex GST)
EZI-Check In Line Metal Detector 350mm x 100mm aperture	03055500	POA
EZI-Check In Line Metal Detector 350mm x 170mm aperture	03055700	POA
EZI-Check In Line Metal Detector 350mm x 250mm aperture	03055600	POA
Dual reject bin module suits 170mm/250mm MD	03055013	POA
Single reject bin module suits 170mm/250mm MD	03055012	POA
EZI-Check Op-06 drop rejector conveyor	03055020	POA
EZI-Check Op-02 flipper rejector conveyor	03055010	POA
Metal Detector test samples (Fe, non-Fe, SUS304, SUS316)	VARIOUS	POA

EZI-CHECK™

Dynamic and Gravity Rollers

Bringing Innovation
to Inspection!

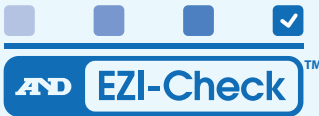

AUSSIE
MADE

NEW
PRODUCT



Specifications	Dynamic Roller (AUTO)	Gravity Roller (BASIC)
Price (ex GST)	\$9,950	\$4,950
Part Number	03051085	03051080
Weighing Capacity	30kg / 60kg / 150kg	30kg / 60kg / 150kg
Resolution	0.01kg / 0.02kg / 0.05kg	0.01kg / 0.02kg / 0.05kg
Conveyor	Powered rollers with PLC control	Heavy duty steel gravity rollers
Dimensions	600 (W) x 450 (D) x 900 (H) mm	
Indicator	Water & dust proof FS-i indicator	
HI / GO / LO	Built in traffic lights	
PC Interface	Wired or wireless options available	

The EZI-Check Auto Dynamic Roller & Basic Gravity Roller scales are freestanding, roller weighing systems that can be incorporated into new or existing production lines allowing precise checking of cartons for missing or damaged products, providing peace of mind.

Dolphin Checkweighers

Customised Dolphin Checkweighing Solutions



AUSSIE
MADE



- Fully customised solutions
- Medium Speed - Maximum 100p/m
- Compact Stainless Steel Design
- Easy Cleaning and maintenance
- Customisable operator display
- Designed to meet the requirement of HACCP
- Weight classification up to 5 Zones and Alarm
- Designed and Manufactured in Australia

	Part Number	Price (ex GST)
A&D Dolphin 4404 Intelligent Checkweigher	03051010	POA
Option 01 - 3 zone colour traffic lamps	03051050	POA
Option 02 - Various reject options	VARIOUS	POA
Multiweigher WIMS Dynamic Weighing Data Suite	06086001	POA
Multiweigher WIMS Sampling Station Data Suite	06086002	POA
AD-4406 Control Cabinet (Trade Approved)	06138430	\$2,395



Process Control Boxes

Basic, Standard, Intelligent

BASIC start/stop control box



Works with any indicator or scale with comparator options

A&D Basic Control Box provides easy installation and termination to customer's equipment.

Uses output device of indicator option.

Can be ordered with 12Vdc or 24Vdc output.

Specifications	BASIC START/STOP
Price (ex GST)	\$445
Part Number	03052000
Output	12 or 24V DC

STANDARD start/stop/jog control box



Works with any indicator or scale with comparator options

A&D Standard Control Box provides easy installation and termination to customer's equipment.

Uses high capacity relays and can be ordered with 12Vdc, 24Vdc or 240Vac output.

Specifications	STANDARD START/STOP/JOG
Price (ex GST)	\$590
Part Number	03052010
Output	12/24V DC OR 240V AC

INTELLIGENT start/stop/jog PLC control box



Works with any indicator or scale with comparator options

A&D Intelligent Control Box includes a PLC which is programmed to customer's requirements.

Specifications	INTELLIGENT START/STOP/JOG
Price (ex GST)	\$825
Part Number	03052020
Output	PLC

CUSTOM consoles/cabinets



Suitable for all A&D

indicators, but ideally suited to the AD-4406, AD-4402 & AD-4404. Fully customised and adaptable to control a wide range of Industry requirements like: Mixing, Batching, Blending, Filling & Emptying, Process Control

Specifications	CUSTOM CONTROL DEVICES
Price (ex GST)	\$POA
Part Number	03053000
Output	PLC

Load Cells



Models	Part Number	Price (ex GST)
ADALC1-T1 1000kg shear beam loadcell (replacement for JAC1000) NMI S536	05070464	\$320
LC-1205-K05-K020 20kg tension/compression loadcell	05025600	\$430
LC-1205-K05-K050 50kg tension/compression loadcell	05025700	\$430
LC-1205-K05-K100 100kg tension/compression loadcell	05025100	\$430
LC-1205-K05-K200 200kg tension/compression loadcell	05025800	\$430
LC-1205-K05-K500 500kg tension/compression loadcell	05025200	\$430
LC-1205-K05-T001 1Tonne tension/compression loadcell	05025300	\$535
LC-1205-K05-T002 2Tonne tension/compression loadcell	05025400	\$645
LC-1205-K05-T005 5Tonne tension/compression loadcell	05025500	\$645
LC-4102-K10 10kg single point loadcell with connector	05120400	\$485
LC-4102-K15 15kg single point loadcell with connector	05120300	\$485
LC-4102-K30 30kg single point loadcell with connector NMI S484	05120200	\$520
LC-4102-K60 60kg single point loadcell with connector	05120100	\$485
LC-4102-K150 150kg single point loadcell with connector	05120500	\$485
LC-4102-K030WP 30kg waterproof loadcell with connector	05120201	\$535
LC-4103-K60 60kg single point loadcell with connector	05110300	\$535
LC-4103-K100 100kg single point loadcell with connector	05110200	\$435
LC-4103-K150 150kg single point loadcell with connector	05110100	\$535
LC-4103-K300 300kg single point loadcell with connector	05110400	\$435
LC-4103-K60WP 60kg waterproof loadcell with connector	05110301	\$570
LC-4103-K100WP 100kg waterproof loadcell with connector	05110201	\$570
LC-4103-K150WP 150kg waterproof loadcell with connector	05110101	\$570
LC-4204-K300 300kg single point loadcell with connector	05015100	\$755
LC-4204-K600 600kg single point loadcell with connector	05015200	\$755
LCB03-K003-M 3kg aluminium single point loadcell without connector	05074000	\$245
LCB03-K006-M 6kg aluminium single point loadcell without connector	05074100	\$245
LCB03-K010-M 10kg aluminium single point loadcell without connector	05074200	\$245
LCB03-K015-M 15kg aluminium single point loadcell without connector	05074300	\$245
LCB03-K020-M 20kg aluminium single point loadcell without connector	05074400	\$245
LCB03-K025-M 25kg aluminium single point loadcell without connector	05074500	\$245
LCB03-K030-M 30kg aluminium single point loadcell without connector	05074600	\$245
LCB03-K035-M 35kg aluminium single point loadcell without connector	05074700	\$245
LCB03-K060-M 60kg aluminium single point loadcell without connector	05074800	\$245
LCB05-K030 30kg stainless steel single point without connector	05075100	\$1,405
LCB05-K060 60kg stainless steel single point without connector	05075200	\$1,405
LCB05-K150 150kg stainless steel single point without connector	05075300	\$1,405
LCC11 T030 weighbridge loadcell (incl. mild steel mounts) NMI S410	05014700	\$1,295
LCC11 T010 weighbridge loadcell (incl. mild steel mounts) NMI S410	05014705	\$1,295
LCC12 T030 tank cell & restraint system (fully cast stainless mounts) NMI S287	05014900	\$4,325
LC5217 T025 shear beam (NMI approved for replacement S287 only) NMI S287	05014600	\$2,160
LCM13-K100 100kg stainless shear beams without connector NMI S446	05073200	\$645
LCM13-K200 200kg stainless shear beams without connector NMI S446	05073300	\$645
LCM13-K300 300kg stainless shear beams without connector NMI S446	05073400	\$645
LCM13-K500 500kg stainless shear beams without connector NMI S446	05072700	\$430
LCM13-T001 1000kg stainless shear beams without connector NMI S446	05072800	\$430
LCM13-T002 2000kg stainless shear beams without connector NMI S446	05072900	\$645
LCM13-T003 3000kg stainless shear beams without connector NMI S446	05073000	\$645
LCM13-T005 5000kg stainless shear beams without connector NMI S446	05073100	\$810
LCZAP1413 Weighing module kit - K100 - T001 (loadcell not included)	05073600	\$755
LCZAP1414 Weighing module kit - T002 - T003 (loadcell not included)	05073700	\$1,295
LCZAP1415 Weighing module kit - T005 (loadcell not included)	05073800	\$2,050
Junction Box stainless steel (incl. 4 input summing PCB)	05070120	\$135
Junction Box stainless steel (incl. 6 input summing PCB)	05070130	\$150
Junction Box stainless steel (incl. 8 input summing PCB)	05070140	\$205

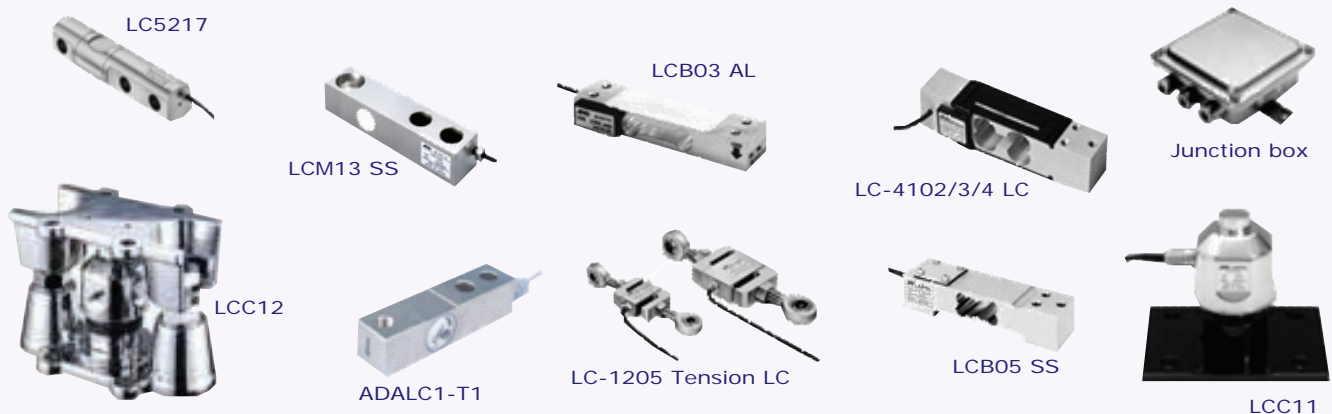



Peripherals

AD-8121 / AD-8920 / AD-1683 / A&D-X Stream

AD-8121 STATISTICAL PRINTER



- Dot-Matrix mechanism, statistic function
- Portable and light weight
- Matrix printer with superior readability
- Buffer memory of up to 30 sets of data
- 24 hour clock, calendar (date / time)

Specifications	AD-8121 STATISTICAL PRINTER	
Price (ex GST)	\$970	
Part Number	06090800	
Dimensions	180(W) x 160(D) x 80.5(H) mm	
Power supply	TB-S200 or 4 x AA size batteries	

Accessories	Part Number	Price (ex GST)
Statistical Printer Paper (each)	MAWP-PP-143	\$11.50
Current loop cable	06090801	\$105
Printer Ribbon	MAET-ECR-05	\$40



SENA BLUETOOTH ADAPTOR

- Sena Bluetooth Adaptors transmits from serial output (for devices with serial comms only) Parani SD-1000

Specifications	SD-1000 SENA BLUETOOTH	
Price (ex GST)	\$300 (EACH)	
Part Number	06087502	

AD-1683 STATIC ELIMINATOR



- The AD-1683 generates positive and negative ions to eliminate static electricity, which is often the cause of inaccurate weighing.
- Ideal for treating your glassware, petri dishes, samples,...
- Can be easily and safely installed because it requires no high-voltage wiring
- Compact and lightweight.
- Little or no reverse charge is induced by irradiated ions because of its excellent ion polarity balance

Specifications	AD-1683 STATIC ELIMINATOR	
Price (ex GST)	\$1,725	
Part Number	06087300	
Dimensions	112(W) x 92(D) x 40(H) mm	
Power supply	TB-S200 (included)	

A&D-X STREAM WIRELESS KIT



The A&D X-Stream 2.4GHz radio modem provides high performance in all industrial and commercial environments. The data transmission range indoor/urban is up to 180 Meters and Outdoor Line of sight of 5Km.

Frequency: 2.4000 - 2.4835 MHz

Spreading Spectrum: Frequency hopping, direct FM

Network Topology:

- Point to point
- Point to Multipoint
- Multi-drop transparent

Channel Capacity: 7 hop sequences share 25 frequencies

Serial Data Interface: Switch selectable RS232/RS422/RS485

I/O Data Rates: Software selectable 1200-57.6K baud

Specifications	A&D-X STREAM WIRELESS KIT	
Price (ex GST)	\$1,975 (PAIR)	
Part Number	06080700	

Peripherals

AD-1688 / AD-8527 / AD-1687 / AD-1691



AD-1688 WEIGHING DATA LOGGER



Save, Store & Retrieve - EASY!



- Dual Interface to import data from an A&D balance to a PC
- No battery. It receives power directly from the balance or PC
- Large memory: up to 5,000 weighing data sets can be stored
- Internal clock and interval mode

Specifications	AD-1688 WEIGHING DATA LOGGER
Price (ex GST)	\$265
Part Number	09022000

AD-8527 QUICK USB ADAPTOR



AD-8527 does 2 things:

- Transmits weighing data directly via the RS-232C port of an A&D balance or scale to the USB port of a PC
- Makes the data available at application level



- Easy to use - no software or driver installation required
- Eliminates operator errors
- Note: EJ balances requires USB to USB cable

Specifications	AD-8527 QUICK USB ADAPTOR
Price (ex GST)	\$265
Part Number	09023000

Accessories	Part Number	Price (ex GST)
Serial to USB conversion cable	03000006	\$85

AD-1687 WEIGHING ENVIRONMENT LOGGER



- Simultaneous and chronological recording of environmental and weighing data.
- Four kinds of environmental data can be added to your records:
 - Temperature (°C / °F),
 - Humidity (%),
 - Barometric pressure (hPa),
 - Vibration (mG)
- Large memory capacity of 10,000 data sets
- Graphic and numeric display of information
- Connects to balance by RS-232C and to PC by USB
- Time stamping of data

Specifications	AD-1687 WEIGHING ENVIRONMENT LOGGER
Price (ex GST)	\$755
Part Number	06037000

AD-1691 WEIGHING ENVIRONMENT ANALYSER

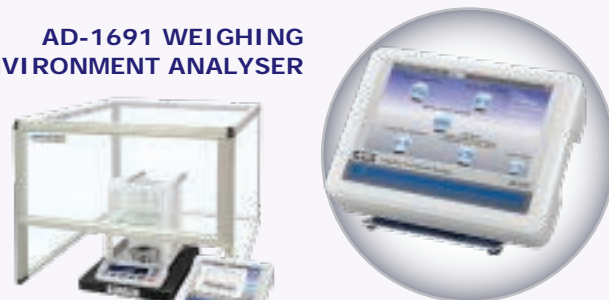

- Easy operation by following step-by-step guidance on a color touch-panel screen
- Daily balance check to confirm that the balance meets proper conditions for use
- Quick glossary for periodic check items
- Documentation of daily/periodic check / calibration results
- Assessment of measurement environment using AND-MEET*1 with the BM series
- Remote balance display and control
- Date and time setting
- Adjustable LCD brightness
- Three kinds of RS-232C cables as standard

Specifications	AD-1691 WEIGHING ENVIRONMENT ANALYSER
Price (ex GST)	\$POA
Part Number	06037100

Testing Products

Pipettes Accuracy Testers



AD-4212B-PT
Pipette is not included



Carry Case

AD-4212A-PT

FX-300i-PT

AD-1690 Leak Tester

- **Save \$\$\$ in unnecessary external Pipette Testing!**
- Very short stabilization times thus increasing the productivity of your pipette calibration activities.
- Compliance with ISO8655 or any other specifications based on the "gravimetric method"
- Standard liquid thermometer and evaporation trap to ensure as precise measurements as possible
- Includes a calibration weight and tweezers for the balance
- Accuracy Testers - Evaporation Trap & Win CT Software included
- AD-1690 Leak tester - Quick 5 seconds test will determine damaged pipettes

Specifications	AD-4212B-PT	AD-4212A-PT	FX-300i-PT
Price (ex GST)	\$11,890	\$9,725	\$4,320
Part Number	06090300	06090301	06090302
Product Description	Pipette Tester	Pipette Tester	Pipette Tester
Capacity	110g / 31g / 5.1g	110g	320g
Resolution	0.1mg / 0.01mg / 1µg	0.1mg	1mg
Compliance	ISO8655 or other specification based on "gravimetric method"		
Power Supply	AC Adaptor TB-S139 included		

Accessories	Part Number	Price (ex GST)
AD-1690 Pipette Leak Tester	06090303	\$2,485
OP-01 Tube Set (AD-1690)	06090304	\$320
OP-02 Filter Set (AD-1690)	06090305	\$320

AD-1653 / AD-1654

Density Determination Kit

The density determination kits (when combined with an analytical or precision balance) allows the density or specific gravity of a solid or liquid to be measured easily and accurately based on Archimedes' Principle.

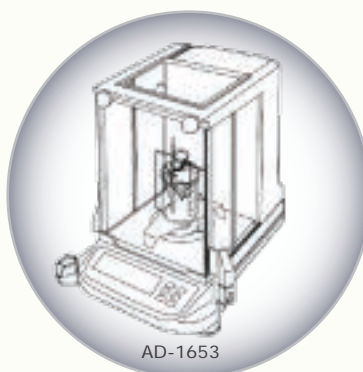

AD-1653

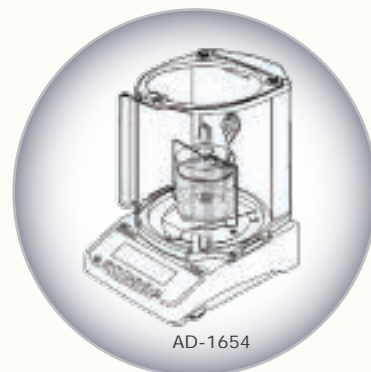

AD-1654

Specifications	AD-1653 DENSITY KIT	AD-1654 DENSITY KIT
Price (ex GST)	\$1,075	\$1,075
Part Number	06036300	06036350
Applicable balances	BM Series / GH Series / GR Series	HR-AZ / HR-A Series / FZ-i Series / FX-i Series

Moisture Analysers

Fast and Uniform Heating

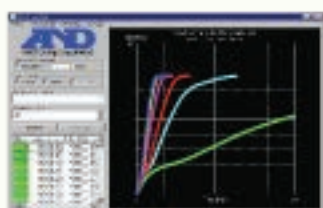

Premium
PRODUCT



- **With PC Connectivity and free Windows graphing software on some models**
- Fast & uniform heating with halogen lamp and innovative SRA technology
- Sample size up to 70g with SHS (Super Hybrid Sensor) and high repeatability
- Can measure moisture content of up to 0.001% resolution
- Standard WinCT-Moisture software for real-time graph displaying on PC (MS & MX only)
- Up to 20 suitable measurement conditions can be stored and recalled, saving time and minimising errors
- Five programmable modes: Standard, Automatic, Quick, Timer & Manual modes
- Selectable heating modes: Standard, Quick, Step & Ramp modes (ML has Quick & Standard modes only)
- Long life halogen lamp is in protective chamber for easy cleaning and lamps can be easily replaced

Specifications	MS-70	MX-50	MF-50	ML-50
Price (ex GST)	\$7,565	\$4,165	\$3,535	\$2,260
Part Number	06036950	06036900	06036400	06036450
Product Description	400W straight halogen lamp heating system with SRA filter and SHS weighing technology			
Moisture Content Display	0.001%/0.01%/0.1%	0.01%/0.1%	0.05%/0.1%/1%	0.1%/1%
Moisture Content Accuracy (Std.D)	0.05%	0.10%	0.20%	0.5%
Moisture Content Accuracy (Std.D)	0.01%	0.02%	0.05%	0.1%
Memory Programs	20 sets		10 sets	5 sets
Data Memory Function	100		50	30
Heating Mode (400W max)	Standard/Quick/Step/Ramp			Standard/Quick
Measurement Programs	Standard Mode / Automatic Mode / Quick Mode / Timer Mode / Manual Mode			
Serial Cable	DB25 Male to DB9 Female (03000001)			
Power Supply	AC Mains			

Accessories	Part Number	Price (ex GST)
MS/MX/MF/ML Halogen lamp (240v 400W)	MAAX-34-240V	\$160
MS/MX/MF/ML Reusable trays (100 pieces)	MAAX-31PANMXMF	\$285
MS/MX Temperature calibration meter	MAAX-43CALMX	\$1,075
MS/MX/MF/ML Plastic display cover (Pack of 2)	MAAX-38COVERMXMF	\$105
MS/MX/MF/ML 15.66% test sample (30g x 12pcs)	MAAX-33TESTMXMF	\$385
MS/MX/MF/ML 15.66% test sample (each)	MAAX-33TESTMXMF-S	\$35



Vibro Viscometers

Unique SV Viscosity Technology

Unique SV Viscosity Technology!



2ml sample measurements (SV-1A)



SV-10/100

● **With FREE PC Connectivity and Windows graphing software**

- Wide measurement range: 0.3 – 10 000mPa-s for SV-10, and 1 000 – 100 000mPa-s for SV-100
- Measure very low viscosities (down to 1/3 of water viscosity!), Temperature measurement from 0 to 160°C
- Fast measurements: 1st result within 15 seconds, and refresh in real time
- Possible continuous measurements in order to characterize changes of state
- High precision with a repeatability of ±1% of displayed value
- Small size sample: cups of 35ml, 13ml, 10ml, and even tubes of 2ml (with SV-1A)
- Possibility to do measurements directly into your containers: beakers, product packages...
- Low mechanical and thermal impact: Preservation of sample characteristics and its texture
- Measurements possible on foaming samples, on foam itself, on flowing or agitated samples
- Simple operation: no configuration - just push on the start button, easy to clean
- Calibration (judgement and even adjustment) of viscosity possible by the user: 1 or 2 points
- Simplified and automated calibration (including adjustment) with pure water (SV-10)

Specifications	SV-1A	SV-10A	SV-10	SV-100
Price (ex GST)	\$10,810	\$10,810	\$8,645	\$8,645
Part Number	06090101	06090102	06090100	06090200
Product Description	0.8-1000 cP / 0.8-1000mPa/s	0.3-1000 cP / 0.3-1000mPa/s	0.3-10,000 cP / 0.3-10,000mPa/s	1-100Pa/s
Measurement range	0.3~1000mPa.s	0.3~10000mPa.s	0.3~1000mPa.s	1000~100000mPa.s
Measurement units	mPa.s, Pa.s, cP, P	mPa.s, Pa.s, cP, P	mPa.s, Pa.s, cP, P	Pa.s, P
Sample size	2ml~	10ml~	10ml~	10ml~
Temperature range	0~160°C / precision 0.1°C			
Serial Cable	DB25 Male to DB9 Female (03000001)			
Power Supply	AC Adaptor TB-S139 included			

Accessories	Part Number	Price (ex GST)
AX-SV-33 10ml Sample cup (10pcs)	MAAX-SV-33	\$265
AX-SV-34 35ml Sample cup (10pcs)	MAAX-SV-34	\$265
AX-SV-58 2ml Sample cup (100pcs)	MAAX-SV-58	\$430
AX-SV-35 13ml Glass Sample Cup	MAAX-SV-35	\$425
AX-SV-36 Vertical Position Lock	MAAX-SV-36	\$315
AX-SV-37 Water Jacket Unit	MAAX-SV-37	\$480
AX-SV-42 Analog Output (0-1V)	MAAX-SV-42	\$1,510
AX-SV-43 5m Display Extension Cable	MAAX-SV-43	\$535

MPA Series

Single Channel Electronic Pipettes



● NEW! Accurate electronic pipettes

- Calibration and display in both volume and weight
- Superior ergonomic design, Multiple dispensing mode, Mixing mode
- 9 different programmable storage memories
- 5 aspirating/dispensing speeds to suit the sample characteristics such as viscosity to ensure accuracy
- Display panel impact absorbing protective pads
- Operation by either an AC adaptor or lithium-ion rechargeable battery

Specifications	MPA-10		MPA-20		MPA-200		MPA-1200	
Price (ex GST)	\$695		\$695		\$695		\$695	
Part Number	MPA-10		MPA-20		MPA-200		MPA-1200	
Product Description	Single channel electronic pipettes							
Capacity	0.5 to 10.0 μ L		2 to 20.0 μ L		10 to 200 μ L		100 to 1200 μ L	
Performance	1.0 μ L	10.0 μ L	2.0 μ L	20.0 μ L	10 μ L	200 μ L	100 μ L	1200 μ L
	\pm 4.0%	\pm 1.0%	\pm 4.0%	\pm 1.0%	\pm 2.5%	\pm 0.6%	\pm 2.5%	\pm 0.5%
	2.5%	0.4%	2.5%	0.4%	1.0%	0.15%	0.6%	0.15%
Weight	Approx. 150g		Approx. 150g		Approx. 160g		Approx. 170g	
Power Supply	AC Adaptor (included) or Lithium-ion battery 3.7V / 920mAh (included)							

Accessories	Part Number	Price (ex GST)
MPA Series battery	AX-BAT-MPA	\$65
MPA AC Adaptor	AX-HA-CHG	\$105
MPA Tip box 10/20/200 μ L	AX-BOX-200A	\$115
MPA Tip box 1200 μ L	AX-BOX-1200A	\$115
MPA Acrylic stand	AX-ST-ACR	\$185
MPA Stainless steel stand	AX-ST-SUS	\$85



AD-4212B

Analytical Production Weighing System

Software	Super Hybrid Sensor
SmartRange	External Calibration
RS-232C Interface	GLP Compliant
LCD Display	Percentage Function
Comparator Function	Counting Function
Options	
LAN-Ethernet Interface	



Display Unit
(included)

AD-4212B
Weighing Unit

High Speed
Durable
Compact
Precise Filling

For maximum efficiency of your production line

Applications such as:

- High-speed weighing
- High-speed check weighing
- Filling
- Isolated weighing

- High resolution and quick stabilization times down to: 2.5 seconds for 0.1mg & 4 seconds for 0.01mg
- Standard RS-232C interface
- Chemically resistant stainless steel sensor unit
- 5-level comparator with contact output and buzzer
- External digital inputs to trigger actions such as RE-ZERO or PRINT
- Data memory, GLP and GMP compliant
- Win CT: software tool for data acquisition from PC
- Multiple weighing units
- VFD screen for easy to read weighing results
- 2m connection cable in between sensor and indicator
- Protection against vertical or transverse shocks - patented

Specifications	AD-4212B-23	AD-4212B-101	AD-4212B-102	AD-4212B-201	AD-4212B-301
Price (ex GST)	\$POA	\$POA	\$POA	\$POA	\$POA
Part Number	Ask for code	06080602	Ask for code	06080800	Ask for code
Capacity	21g	31g / 110g	110g	210g	310g
Resolution	0.001mg	0.01mg / 0.1mg	0.01mg	0.1mg	0.1mg
Dimensions	Weighing unit: 80(W) x 230(D) x 90(H); Display unit: 237(W) x 150(D) x 155(H) mm				
Pan Size	Ø 34mm			50mm x 50mm	
Connection Cable	Approx. 2m between weighing unit and display unit				
Power Supply	AC Adaptor TB-S139 included				

● ex Japan

AD-4212C

Production Line Weighing System



For maximum efficiency of your production line

Applications such as:

- High-speed weighing
- High-speed check weighing
- Filling
- Isolated weighing

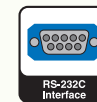

Options



- High resolution and quick stabilization times down to: 0.5 second up to 30 grams & 1.0 second up to maximum capacity
- Possibility to use a weighing pan of your own design for holding special objects
- Protected against vertical and transverse overloading (patent pending)
- Outputs digital weighing data directly to a panel computer, PLC or PC via standard RS-232C interface
- Analog, comparator, and BCD outputs are also possible through the optional AD-8922A controller
- High-speed data transmission of up to 50 times/second
- IP65 dust and water-proof construction for powder or liquid weighing
- Easy calibration and response speed adjustment using WinCT-AD4212C software
- Calibration weight included
- Connection cable included (about 5 m)
- Securable to a base by replacing levelling feet with screws

Specifications	AD-4212C-301	AD-4212C-300	AD-4212C-600	AD-4212C-3100	AD-4212C-3000
Price (ex GST)	\$POA	\$POA	\$POA	\$POA	\$POA
Part Number	Ask for code	Ask for code	06080900	06081000	Ask for code
Capacity	51g / 320g	320g	620g	510g / 3200g	3200g
Resolution	0.0001g / 0.001g	0.001g	0.001g	0.001g / 0.01g	0.01g
Dimensions	59(W) x 231(D) x 91(H) mm				
Pan Size	50mm x 50mm				
Connection Cable	Approx 10m				
Power Supply	AC Adaptor TB-S139 included				

● ex Japan

Accessories	Part Number	Price (ex GST)
AD-8923CC Remote Controller	Please Inquire	\$POA



MC Series

Mass Comparator Precision Balances



(MC-10K/30K)



(MC-10K/30K)

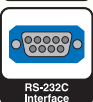

- Used for Mass Verification
- Precision balance with extended resolution



MC-10K



MC-6100

- Extra decimal place for monitoring fine weight changes with heavy tare weights
- Stabilizing filter to lessen errors due to drafts or vibrations
- Auto-centering pan to avoid corner-load errors and ensure higher accuracy (optional)
- Internal calibration mass for simplified calibration of the balance
- Equipped with a glass breeze break (MC-1000/6100) or simple breeze break (MC-10K/30K) as standard
- Fast stabilization of approx. 1.5 seconds
- GLP/GMP/GCP/ISO compliant output
- Large bright vacuum fluorescent display
- Multiple weighing units of measurement



Auto-centering pan (option) realises mass comparison with higher accuracy by correcting eccentric loadings.

Specifications	MC-1000	MC-6100	MC-10K	MC-30K
Price (ex GST)	\$9,725	\$9,725	\$10,295	\$10,810
Part Number	06036010	06036060	06036000	06036030
Capacity	1100g	6100g	10.1kg	30kg
Resolution	0.0001g	0.001g	0.001g	0.01g
Dimensions	210(W) x 317(D) x 86(H) mm		300(W) x 355(D) x 111(H) mm	
Pan Size	128mm x 128mm	165mm x 165mm	270mm x 210mm	
Serial Cable	DB9 Female to DB9 Female (03000007)			
Power Supply	AC Adaptor TB-S139 included			

ex Japan

Accessories	Part Number	Price (ex GST)
Auto centering pan for MC Series	06036001	\$1,510

ex Japan

Health Scales

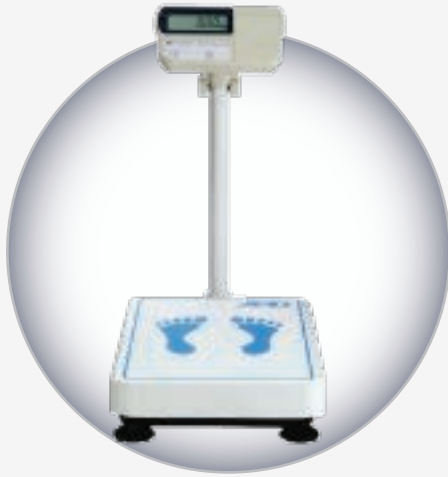

**PW-200KGL
PROFESSIONAL PLATFORM SCALE**

- 220kg capacity with 20g resolution
- AC Adaptor (TB-S200) or battery operated

Specifications	PW-200KGL
Price (ex GST)	\$1,080
Part Number	03160600
Capacity	220kg x 20g



**HVL-CS
CHAIR SCALE**

- 150kg capacity with 20g resolution
- Battery Operated. Adaptor not included

Specifications	HVL-CS CHAIR SCALE
Price (ex GST)	\$2,160
Part Number	03040610
Capacity	150kg x 20g



**PERSONAL
SCALES**

- UC-321 Series with 150kg / 200kg capacity
- UC-331 Wellbeing with 150kg capacity
- Portable & Light weight
- Battery Operated

Specifications	UC-321	UC-321PL	UC-331 WELLBEING
Price (ex GST)	\$295	\$295	\$70
Part Number	09030200	09030800	09030101
Calibration	150kg x 50g	200kg x 100g	150kg x 100g
Dimensions	310(W) x 310(D) x 20(H) mm	310(W)x300(D)x20(H)	

HIGH CAPACITY PERSONAL SCALES



- AD-6121A: 150kg capacity with 100g resolution
- UC-355 with 250kg capacity
- Portable & Light weight
- Battery Operated

Specifications	AD-6121A	UC-355
Price (ex GST)	\$395	\$385
Part Number	09030900	09030901
Capacity	150kg x 100g	250kg*

*UC-355: 100g resolution from 1-100kg & 200g resolution from 100kg - 250kg



Excellence in Measurement

Head Office & Factory
32 Dew Street
THEBARTON
South Australia 5031
Tel: (08) 8301 8100
Fax: (08) 8352 7409

Victorian Office
39 Bakehouse Road
KENSINGTON
Victoria 3031
Tel: (03) 9371 1555
Fax: (03) 9372 1193

New South Wales Office
Unit 4, 14 Abbott Road
SEVEN HILLS
New South Wales 2147
Tel (02) 9674 5466
Fax: (02) 9674 2544

www.andaustralasia.com.au
sales@andaustralasia.com.au