

AD-1654

INSTRUCTION MANUAL

DENSITY DETERMINATION KIT

HR-AZ series
HR-A series
FZ-*i* series
FX-*i* series

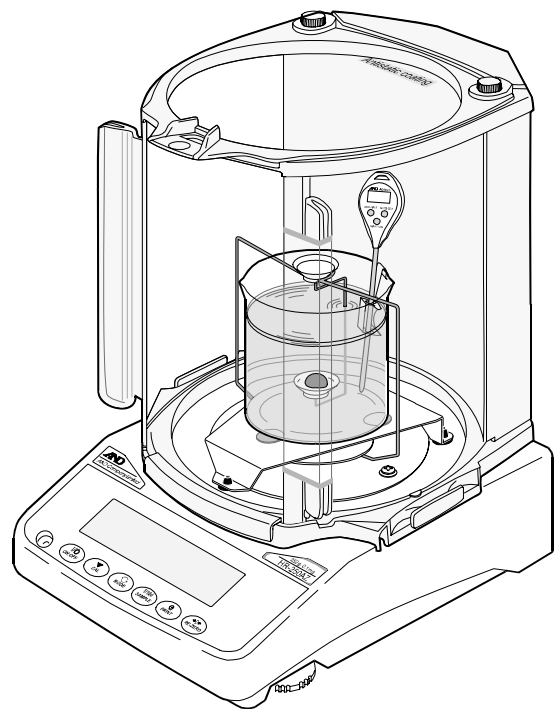



AND

A&D Company, Limited

This Manual and Marks

Product Safety Signs and Labels

All safety messages are identified by the following, “WARNING” or “CAUTION”, of ANSI Z535.4 (American National Standard Institute: Product Safety Signs and Labels). The meanings are as follows:

 WARNING	A potentially hazardous situation which, if not avoided, could result in death or serious injury.
 CAUTION	A potentially hazardous situation which, if not avoided, may result in minor or moderate injury.
Note	Provides information useful for the user to operate the instrument.

 This is a hazard alert mark.

Note

- This manual is subject to change without notice at any time to improve the product.
- The contents of this manual and the specifications of the instrument covered by this manual are subject to change for improvement without notice.

© 2012 A&D Company Ltd. All rights reserved.

No part of this publication may be reproduced, transmitted, transcribed, or translated into any language in any form by any means without the written permission of A&D Company Ltd.

Contents

1.	Introduction	2
1-1.	Precautions.....	2
2.	Unpacking The Kit.....	2
3.	Density Measurement Principles	3
3-1.	Density.....	3
3-2.	Specific Gravity.....	3
3-3.	Archimedes' Principle Of Density Measurement.....	3
3-4.	Density Of A Solid.....	3
3-5.	Density Of A Liquid	3
4.	Error Factors	4
4-1.	Buoyancy Of Air.....	4
4-2.	Volume Of Float.....	4
4-3.	Temperature Of Liquid.....	4
4-4.	Influence Of Wire.....	5
4-5.	Surface Tension.....	5
4-6.	Bubbles.....	5
5.	Measuring The Density Of A Solid	6
5-1.	Assembling The Kit: HR-AZ / HR-A Series.....	6
5-2.	Assembling The Kit: FZ- <i>i</i> / FX- <i>i</i> Series.....	7
5-3.	Measuring The Density Of A Solid.....	8
6.	Measuring The Density Of A Liquid.....	10
6-1.	Assembling The Kit:.....	10
6-2.	Measuring The Density Of A Liquid	10
7.	Frequently Asked Questions	11
8.	Water Resistant Digital Thermometer AD-5625.....	12

1. Introduction

Thank you for purchasing the AD-1654 density determination kit. The AD-1654, when combined with one of A&D electronic balances (HR-AZ / HR-A and FZ-*i* / FX-*i* series), allows the density of a solid and liquid to be measured easily. Before using the AD-1654, please read this manual thoroughly and keep it at hand for future reference.

1-1. Precautions

- The kit allows the density of a solid or liquid to be measured. However, the results of measurements may be affected by various factors that could cause errors.
- Do not use the kit for measuring the density of chemically active substances.
Ex.: strong acid, strong alkali solution.
- After using the density determination kit, clean all surfaces to remove rust and oxides.
- A balance is a precision instrument. Avoid shocks and excessive loads.
- Maintain the ambient temperature, samples and the kit at a constant temperature.
- Use the AD-1654 with A&D electronic balances (HR-AZ / HR-A and FZ-*i* / FX-*i* series).

2. Unpacking The Kit

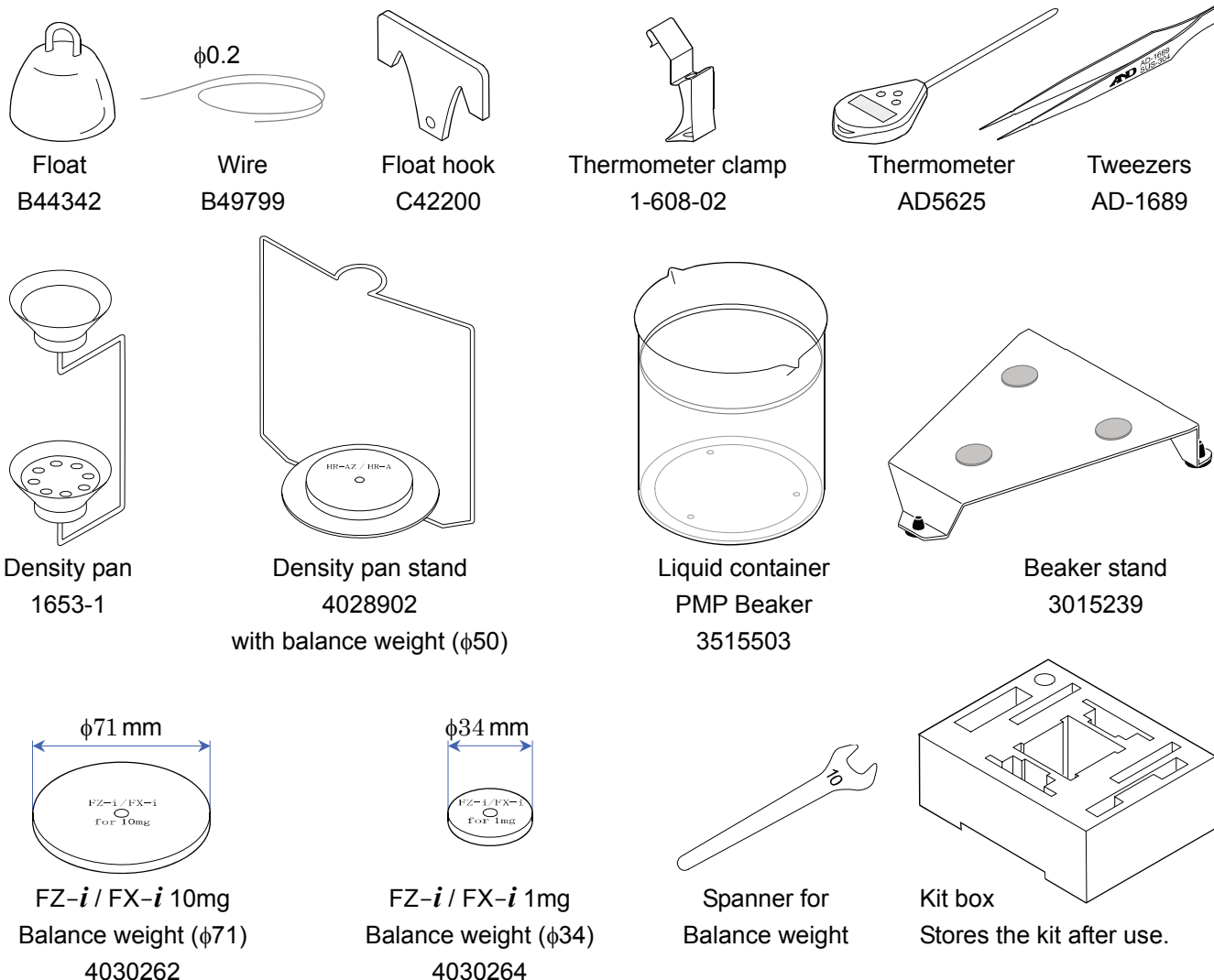

3. Density Measurement Principles

3-1. Density

Density refers to the total mass of a sample per unit volume.

$$\rho = \frac{M}{V} \quad (\text{Unit: g/cm}^3)$$

- ρ : Density of sample (g/cm³)
- M : Mass (g)
- V : Volume (cm³)

3-2. Specific Gravity

Specific gravity refers to the ratio of the density of a sample to the density of pure water at 4°C under a pressure of 1013.25 hPa.

$$\rho = \frac{M}{V \times \rho_4} \quad (\text{No unit})$$

- ρ : Density of sample (g/cm³)
- M : Mass (g)
- V : Volume (cm³)
- ρ_4 : Density of water at 4°C
(0.99997 g/cm³ \approx 1.000 g/cm³)

3-3. Archimedes' Principle Of Density Measurement

The AD-1654 is combined with an electronic balance to measure the density of a sample based on the Archimedes' principle.

Archimedes' principle

A body immersed in a liquid (or a gas) is subject to an upward force equal to the weight of the liquid (or the gas) it displaces. The upward force is buoyancy.

3-4. Density Of A Solid

The density of a solid can be obtained according to the weight of the sample in air, the weight of the sample in liquid and the density of the liquid.

$$\rho = \frac{M}{A - B} \times (\rho_0 - d) + d$$

- ρ : Density of sample (g/cm³)
- A : Weight of sample in air (g)
- B : Weight of sample in liquid (g)
- ρ_0 : Density of liquid (g/cm³)
- d : Density of air (approx. 0.001 g/cm³)

3-5. Density Of A Liquid

The density of a liquid can be obtained according to the weight of float in air, the weight of float in liquid and the known volume of float.

$$\rho = \frac{A - B}{V} + d$$

- ρ : Density of liquid (g/cm³)
- A : Weight of float in air (g)
- B : Weight of float in liquid (g)
- V : Volume of float (cm³)
- d : Density of air (approx. 0.001 g/cm³)

4. Error Factors

The results of measurements may be affected by various factors that could cause errors

4-1. Buoyancy Of Air

- A density measurement is influenced by an upward force of 0.0010 to 0.0014 g/cm³ (buoyancy of air).
- The density of air can be obtained by the equation below:

$$d = \frac{0.0012932}{1 + 0.0036728 \times t} \times \frac{P}{1013.25}$$

d : Density of air (g/cm³)
t : Air temperature (°C)
P : Atmospheric pressure (hPa)

- When measurement accuracy of three significant digits is necessary, consider the buoyancy of air, add 0.001 g/cm³ to the measured value to compensate for the error due to the air density.

4-2. Volume Of Float

- The tolerance of the measured value of the volume of the float is ±0.01 cm³.
In liquid density measurement, the decimal places beyond the third decimal place of the measured value contain errors.
- When measurement accuracy to the third decimal place or beyond is necessary, measure the volume of the float using distilled water.

$$d = \frac{A - B}{\rho - d} - 0.0035$$

- V : Volume of float (cm³)
A : Mass of float in air (g)
B : Mass of float in liquid (g)
ρ : Density of distilled water at t °C (g/cm³)
d : Buoyancy of air at t °C (g/cm³)
0.0035 : Correction value for the wire (diameter of 1 mm) of the density pan connecting the upper and lower pans (when the beaker provided with this kit is used)

4-3. Temperature Of Liquid

- The density of the liquid that is used for measuring the density of a solid varies with the liquid temperature. Therefore, the decimal places beyond the second decimal place of the measured value contain errors.
- Obtain the density of a liquid according to the temperature from Table 1 for distilled water or from other reference documents for other liquids.
- When measurement accuracy to the third decimal place or beyond is necessary, use a thermometer with a tolerance of ±0.2 °C or less.

4-4. Influence Of Wire

- In solid density measurement, the surface of the liquid rises when a solid sample is placed on the density pan, which is immersed in the liquid. At this time, the buoyancy corresponding to the weight of the raised liquid is exerted on the wire (diameter of 1 mm) connecting the upper and lower pans. If the surface of the liquid rises 1 mm, the buoyancy exerted on the wire is about 0.8 g/cm^3 . To minimize the error due to the buoyancy, select a sample with a smaller volume or correct the value by calculation.
- In liquid density measurement, a force (buoyancy) is exerted on the wire (diameter of 0.2 mm) suspending the float, when immersed in the liquid. Immersing the wire by 10 mm exerts a buoyancy of about 0.3 mg on the wire. However, this buoyancy influence can be ignored. When obtaining the liquid density, the difference between the weight of the float in air and in water is divided by the volume of the float, as described in "**3-5. Density of a Liquid**". This calculation reduces the error due to buoyancy such that it is negligible.

4-5. Surface Tension

- In solid density measurement, a force (surface tension) of about 5 mg is exerted on the pan between the wire (diameter of 1 mm) of the density pan and the liquid surface.
- The surface tension can be reduced by about 1 mg by adding a surfactant (for example, a wetting agent used for developing photographs). Adding 0.1 mL (density: 1.2 g/cm^3) of a surfactant to 200 mL of water will increase the density of water by about 0.0001 g/cm^3 .
- In liquid density measurement, a force (surface tension) of about 1 mg is exerted on the wire (diameter of 0.2 mm) suspending the float. However, this surface tension influence can be ignored. When obtaining the liquid density, the difference between the weight of the float in air and in water is divided by the volume of the float, as described in "**6. Measuring The Density Of A Liquid**". This calculation reduces the error due to surface tension such that it is negligible.

4-6. Bubbles

- The buoyancy of a bubble of 1 mm in diameter is about 0.5 mg. Bubble generation depends on the shape and material of the sample, so take care when making measurements.
- In solid density measurement, a surfactant may be added to reduce the influence of bubbles.

5. Measuring The Density Of A Solid

Assemble the kit as described in the procedure below. Note that the assembly procedure depends on the balance model.

5-1. Assembling The Kit: HR-AZ / HR-A Series

1. Remove the weighing pan, pan support, breeze break ring and dust plate from the balance.
 2. Fasten the balance weight ($\phi 50$) and spring washer to the density pan stand with the cone boss.
(In the first time ,they are assembled in factory)
 3. Place the density pan stand on the balance.
 4. Place the beaker stand so that it does not touch the density pan stand.
 5. Attach the thermometer clamp to the beaker and insert the thermometer into the thermometer clamp.
 6. Pour a liquid with a known density (such as distilled water) into the beaker and place the beaker on the beaker stand.
 7. Place the density pan on the density pan stand.
 8. Adjust the amount of the liquid so that the sample, when placed on the lower pan (in the liquid), is about 10 mm below the surface of the liquid.
 9. When the value displayed on the balance is stable, press the **RE-ZERO** key to set the displayed value to zero. Now the balance is ready for density measurement.
- HR-AZ / HR-A series balances are equipped with a density mode to calculate the density of a solid. For details, refer to the instruction manual of HR-AZ / HR-A series.

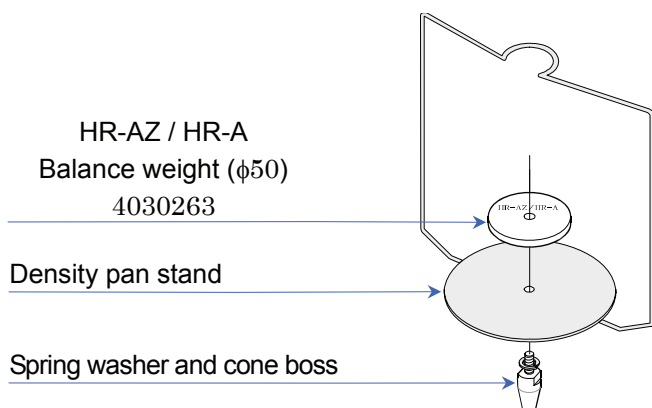
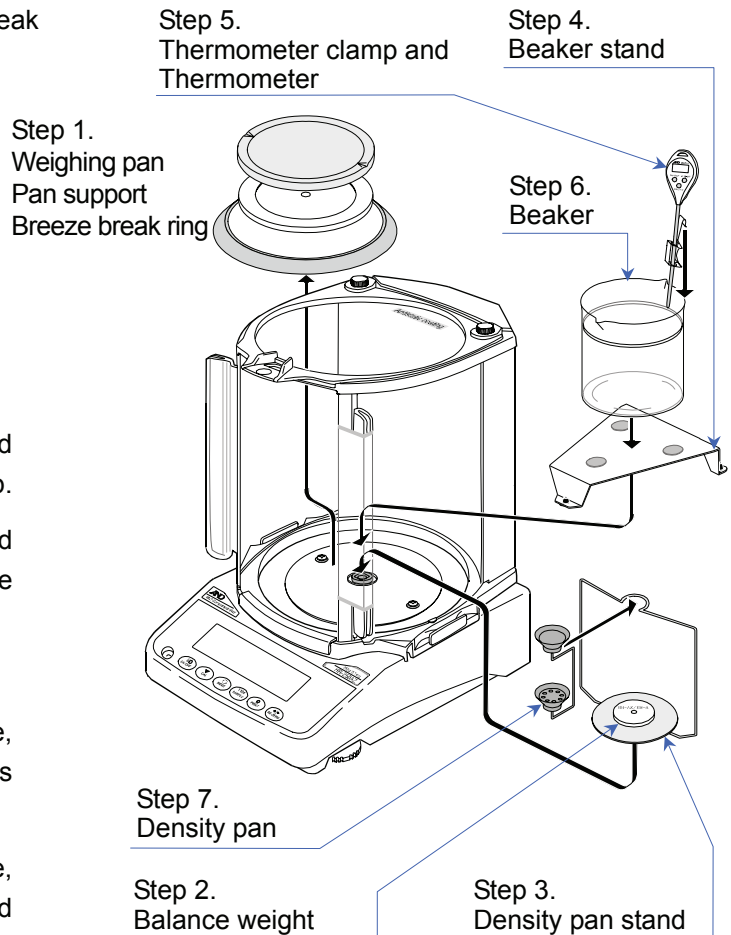

Fasten the balance weight and spring washer to the density pan stand with the cone boss. (Assembled in factory)

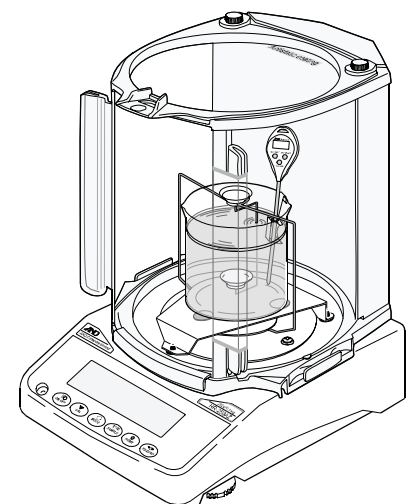

HR-AZ / HR-A series
for density measurement

5-2. Assembling The Kit: FZ-*i* / FX-*i* Series

1. Remove the weighing pan, pan support and breeze break from the balance.
2. Fasten a proper balance weight and spring washer to the density pan stand with the cone boss.

Mini. display	Models	Balance weight	Number
10 mg	FX-1200 <i>i</i> , FX-2000 <i>i</i> , FX-3000 <i>i</i> , FX-5000 <i>i</i> , FZ-1200 <i>i</i> , FZ-2000 <i>i</i> , FZ-3000 <i>i</i> , FZ-5000 <i>i</i>	Balance weight(φ71)	4030262
1 mg	FX-120 <i>i</i> , FX-200 <i>i</i> , FX-300 <i>i</i> , FX-500 <i>i</i> , FZ-120 <i>i</i> , FZ-200 <i>i</i> , FZ-300 <i>i</i> , FZ-500 <i>i</i> ,	Balance weight(φ34)	4030264

3. Place the density pan stand on the balance.
4. Place the beaker stand so that it does not touch the density pan stand.
5. Attach the thermometer clamp to the beaker and insert the thermometer into the thermometer clamp.
6. Pour a liquid with a known density (such as distilled water) into the beaker and place the beaker on the beaker stand.
7. Place the density pan on the density pan stand.
8. Adjust the amount of the liquid so that the sample, when placed on the lower pan (in the liquid), is about 10 mm below the surface of the liquid.
9. When the value displayed on the balance is stable, press the **RE-ZERO** key to set the displayed value to zero. Now the balance is ready for density measurement.

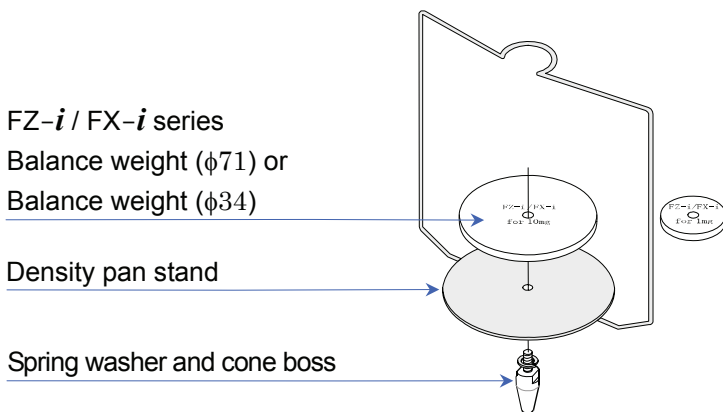
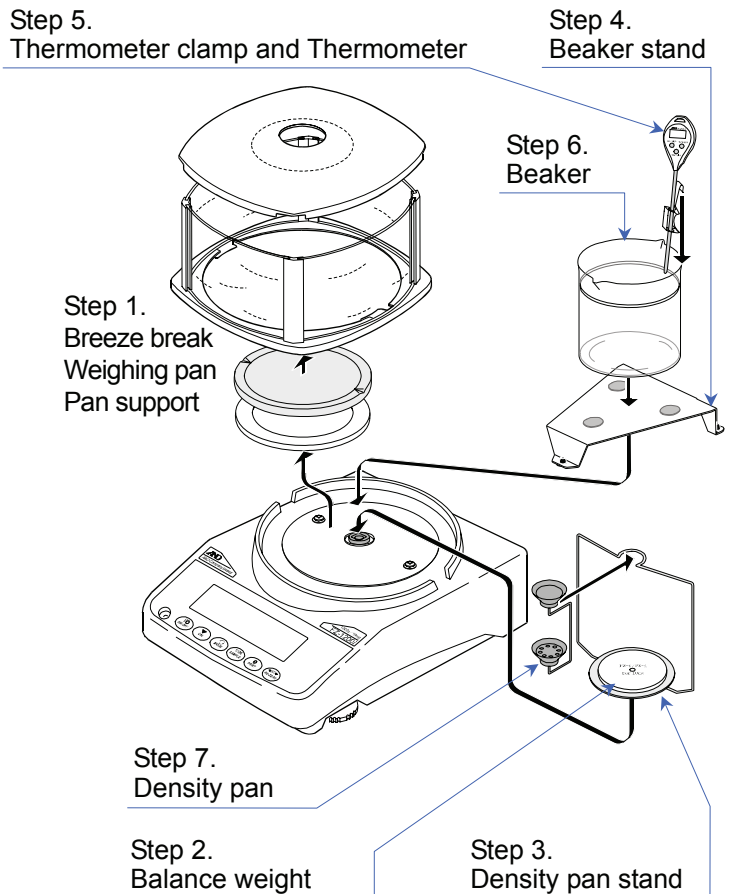

Fasten the balance weight and spring washer to the density pan stand with the cone boss. (Assembled in factory)

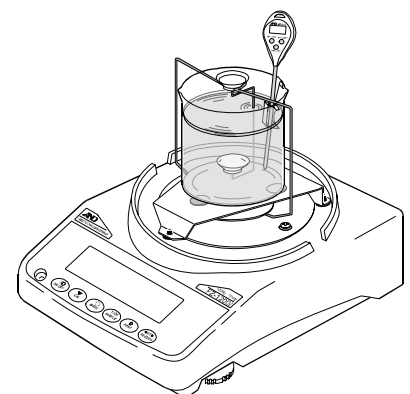

5-3. Measuring The Density Of A Solid

- The density of a solid is obtained by averaging the measured values.
1. Start the measurement when water temperature becomes stable.
 2. Press the **RE-ZERO** key to set the displayed value to zero.
 3. Place the sample on the upper pan in air and record the value A.
 4. Press the **RE-ZERO** key to set the displayed value to zero.
 5. Place the sample on the lower pan in liquid and record the value B.
 - Keep the depth of approximately 10 mm under liquid surface.
 6. Obtain the density of water according to the temperature. (Refer to **Table 1**)

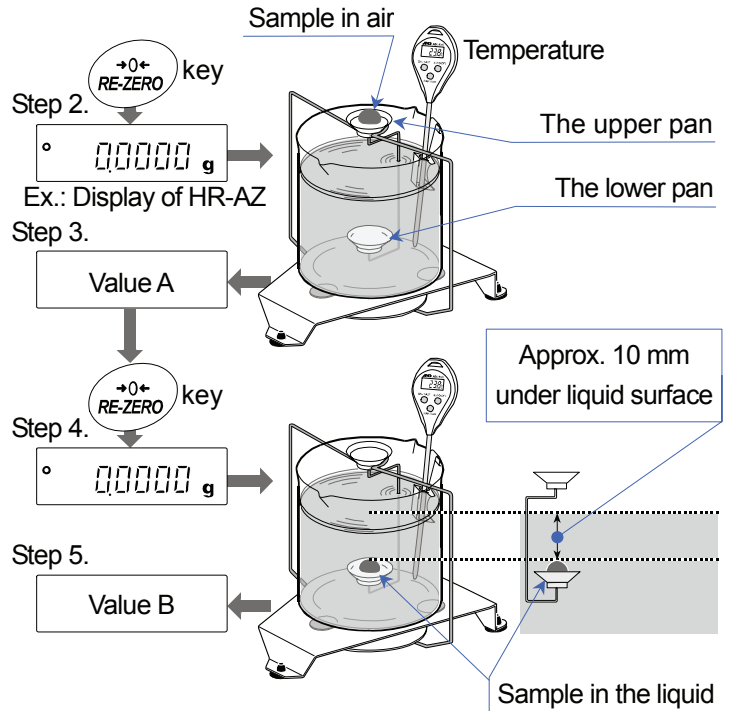

Table 1 Density of distilled water

Temperature °C	+0	+1	+2	+3	+4	+5	+6	+7	+8	+9
0	0.99984	0.99990	0.99994	0.99996	0.99997	0.99996	0.99994	0.99990	0.99985	0.99978
10	0.99970	0.99961	0.99949	0.99938	0.99924	0.99910	0.99894	0.99877	0.99860	0.99841
20	0.99820	0.99799	0.99777	0.99754	0.99730	0.99704	0.99678	0.99651	0.99623	0.99594
30	0.99565	0.99534	0.99503	0.99470	0.99437	0.99403	0.99368	0.99333	0.99297	0.99259
40	0.99222	0.99183	0.99144	0.99104	0.99063	0.99021	0.98979	0.98936	0.98893	0.98849
50	0.98804	0.98758	0.98712	0.98665	0.98618	0.98570	0.98521	0.98471	0.98422	0.98371
60	0.98320	0.98268	0.98216	0.98163	0.98110	0.98055	0.98001	0.97946	0.97890	0.97834
70	0.97777	0.97720	0.97662	0.97603	0.97544	0.97485	0.97425	0.97364	0.97303	0.97242
80	0.97180	0.97117	0.97054	0.96991	0.96927	0.96862	0.96797	0.96731	0.96665	0.96600
90	0.96532	0.96465	0.96397	0.96328	0.96259	0.96190	0.96120	0.96050	0.95979	0.95906

At sea level (1 atmosphere), the density of water reaches maximum at 3.98 °C.

Unit: g/cm³

7. Use the following equations to obtain the density.

Three significant digits:

$$\rho = \frac{A}{|B|} \times \rho_0$$

Four or more significant digits:

$$\rho = \frac{M}{|B|} \times (\rho_0 - d) + d$$

ρ : Density of sample (g/cm³)

A : Value A : Weight of sample in air (g)

B : Value B : | Weight of sample in air - Weight of sample in liquid | (g)

ρ_0 : Density of liquid (g/cm³)

d : Density of air (approx. 0.001 g/cm³)

Example of recording sheet

Value A : Weight of sample in air (g)	4.8102 g
Value B : Weight of sample in air – Weight of sample in liquid (g)	0.5946 g
Temperature of liquid (°C)	26 °C
Density of liquid (g/cm ³)	0.99678 g/cm ³
$\rho = \frac{\text{Weight of sample in air}}{\left \begin{array}{l} \text{Weight of sample} \\ \text{in air} \end{array} \right - \left \begin{array}{l} \text{Weight of sample} \\ \text{in liquid} \end{array} \right } \times \text{Density of liquid (g/cm}^3\text{)}$	8.06 g/cm ³ (Calculated)

Value A : Weight of sample in air (g)	4.8102 g
Value B : Weight of sample in air – Weight of sample in liquid (g)	0.5946 g
Temperature of liquid (°C)	26 °C
Density of liquid (g/cm ³)	0.99678 g/cm ³
Atmospheric pressure (hpa)	1013 hpa
Density of air (g/cm ³)	0.0012 g/cm ³
$\rho = \frac{\text{Weight of sample in air}}{\left \begin{array}{l} \text{Weight of sample} \\ \text{in air} \end{array} \right - \left \begin{array}{l} \text{Weight of sample} \\ \text{in liquid} \end{array} \right } \times (\text{Density of liquid} - \text{Density of air}) + \text{Density of air (g/cm}^3\text{)}$	8.055 g/cm ³ (Calculated)

6. Measuring The Density Of A Liquid

Assemble the kit as described in the procedure below.

6-1. Assembling The Kit:

1. For the procedure up to the setting of the beaker stand, refer to the assembly procedure for each balance model described in "5.Measuring The Density Of A Solid".
2. Attach the thermometer clamp to the beaker and insert the thermometer into the thermometer clamp.
3. Place the beaker on the beaker stand.
4. Connect the float to the float hook using the wire. The length of wire must be approx. 30 mm.
5. Hook the float hook on the density pan stand.
6. When the value displayed on the balance is stable, press the **RE-ZERO** key to set the displayed value to zero. Now the balance is ready for density measurement.

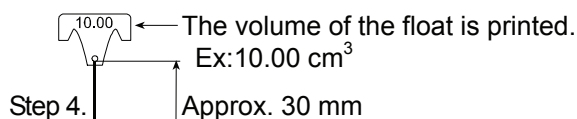
Step 4.  The volume of the float is printed.
Ex:10.00 cm³
Approx. 30 mm

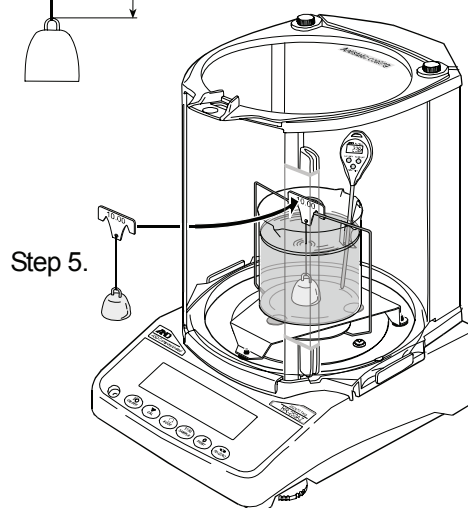

Example of the assembled HR-AZ series

6-2. Measuring The Density Of A Liquid

□ Use the following procedure to obtain the density of a liquid.

1. With the float hanging, press the **RE-ZERO** key to set the displayed value to zero.
2. Pour the liquid of which you want to measure the density into the beaker.
 - Make sure that the float is about 10 mm below the surface of the liquid.
3. When the value displayed on the balance is stable, record the value A ignored the minus sign.
4. Use the following equations to obtain the density of the liquid.

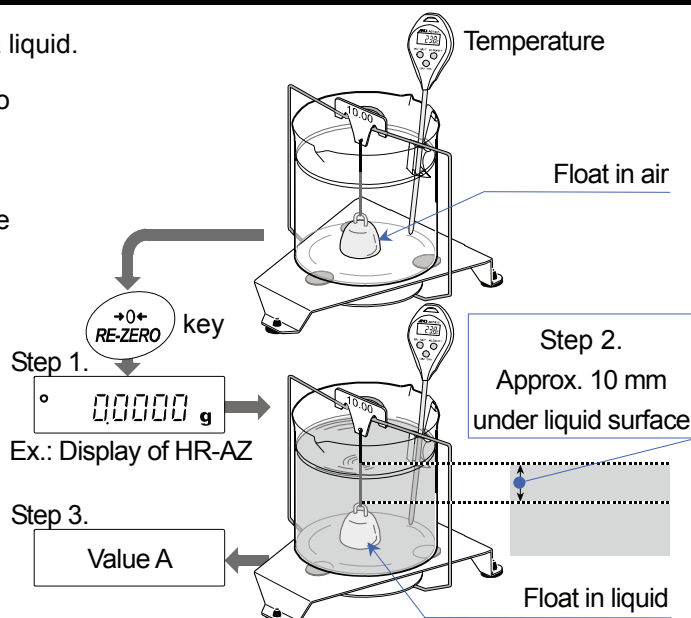

$$\rho = \frac{|A|}{V} + d$$

ρ : Density of liquid (g/cm³)

A : | Weight of float in air - Weight of float in liquid | (g)

V : Volume of float (cm³)

d : Density of air (approx. 0.001 g/cm³)

Example of recording sheet

Value A : Weight of float in air – Weight of float in liquid (g)	9.9704 g
Temperature of liquid (°C)	25 °C
Volume of float (g/cm ³)	10.01 cm ³
Density of air (g/cm ³)	0.001 g/cm ³
$\rho = \frac{\left \begin{array}{c} \text{Weight of float} \\ \text{in air} \end{array} \right - \left \begin{array}{c} \text{Weight of float} \\ \text{in liquid} \end{array} \right }{\text{Volume of float}} + \text{Density of air (g/cm}^3\text{)}$	0.997 g/cm ³ (Calculated)

7. Frequently Asked Questions

Questions	Answers
I'd like to measure the density of a resin pellet or sheet, which floats in water. Is it possible?	Use a liquid that has a lower density than water and does not dissolve the sample, such as methanol (density 0.798) or kerosene (density 0.80). The density of the liquid used is measured using the float provided with the kit.
Can a sample containing bubbles be measured?	The density of a sample with bubbles can be measured as it is. But as time passes, the bubbles disappear and the apparent density may change. A sample that floats in water due to the low density can not be measured.
The measurement repeatability may be affected by the water's surface tension. What can I do about this?	A few drops of a surfactant (for example, a mild detergent for washing dishes) added to the water reduce the influence of surface tension. A few drops of a surfactant will affect the liquid density only a very small amount. When methanol is used in place of water, the influence of surface tension is small, even without a surfactant.
When tap water is used, bubbles are gradually generated on the sample surface and a measurement error occurs. What can I do about this?	Tap water contains dissolved gases such as oxygen and carbon dioxide. When tap water is used, the released dissolved gases generate bubbles. It is recommended that pure water or distilled water, which contains few dissolved gases, be used.
When I try to measure a highly water- repellent material such as rubber, bubbles stick to the sample. What can I do about this?	Before measurement, soak the sample in the water with an appropriate amount of surfactant added. Doing this increases the sample surface hydrophilicity and makes it more difficult for bubbles to stick to the sample surface.
Up to what size of sample can be measured?	In consideration of the density pan size, the maximum sample size that can be measured is: Diameter ϕ 25 mm, Height 30 mm, Mass 100 g
Can I measure the density of a liquid with a high viscosity?	A liquid with a viscosity up to 500 mPa·s can be measured. If the viscosity exceeds this value, the float takes excessive time to sink and a measurement error occurs. Measuring adhesive is not recommended because the adhesive sample may be difficult to remove from the float.
Does using a semi-micro balance improve accuracy?	The effects of surface tension cause errors in the measurement value of around 0.2 to 1.0 mg. In measurement using the 0.1 mg range, the magnitude of error and the level of balance accuracy are almost the same. In measurement using the 0.01 mg range, the magnitude of error greatly exceeds the level of balance accuracy, so using a semi-micro balance is not recommended.

8. Water Resistant Digital Thermometer AD-5625

Safety Use

Consider the following notices when operating the thermometer.

⚠ Caution

□ Repair and Arrangement

Authorized person can only repair the AD-5625. Do not open the case to repair the AD-5625. Attempting repairs yourself may cause damage to the AD-5625. Damage caused by attempting to do the repair yourself will void the warranty.

□ Malfunction

When the AD-5625 malfunctioning, stop the use and remove the batteries. Contact the local A&D dealer if the AD-5625 needs service or repair.

Cautions

- Do not drop the AD-5625. Avoid mechanical shock to the AD-5625.
- Do not install the scale where flammable or corrosive gas is present.
- Do not install the AD-5625 into underwater for long time and into extreme high temperature and low temperature.
- The AD-5625, has case of double structure, can prevent from invading water.

Features

The features of the AD-5625 is as follows:

- Waterproof class is IPX7. The AD-5625 is washable.
- With the $\phi 2.8$ sensor sheath, the AD-5625 can measure temperature of gas, liquid and can use for internal temperature measurement of solid.
- The maximum temperature and minimum temperature are stored automatically and can be read after measurements.
- The refresh rate of temperature measurement can be changed with button.
- The temperature range is from $-50\text{ }^{\circ}\text{C}$ to $260\text{ }^{\circ}\text{C}$.
- The automatic power-off function that turns off the AD-5625 left in the measurement is installed in.
- The sheath folder to keep the sensor sheath is included in accessory.

Names

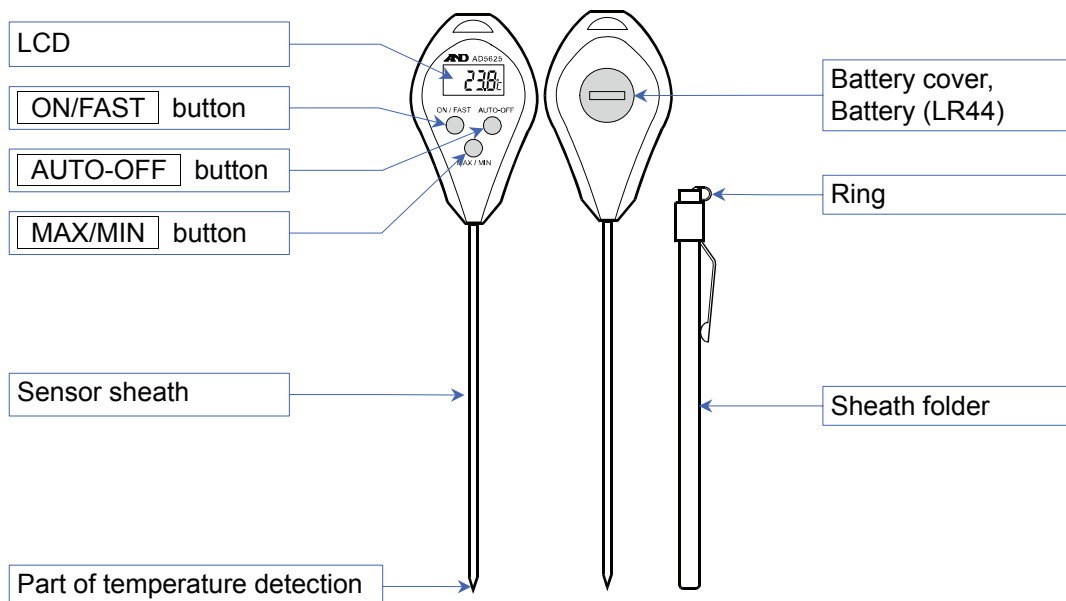

Precautions

The thermometer includes a monitor battery.

Refer to "Replacing the battery" before a measurement, open the battery cover and install the battery.

When installing the battery, a current temperature is displayed.

The accessory battery is for an operation monitor and may be short battery life.

Replacing The Battery

A coin battery (LR44) is used. When displaying faint characters, replace the battery as follows:

1. Turn over the AD-5625. Turn the battery cover in a counterclockwise and remove it.
2. Remove an old battery.
3. Install the battery so that its plus side (+, flat side) is upper face.
4. Reattach the battery cover and turn it in clockwise.

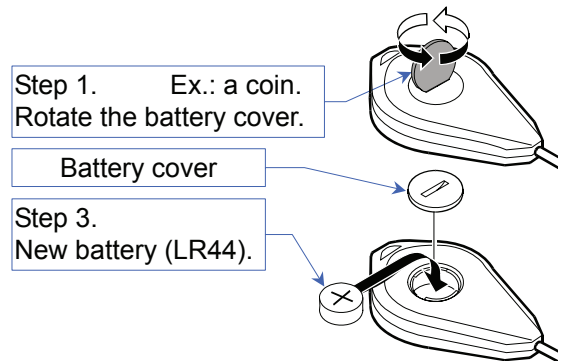

⚠ Caution

- ❑ Be sure to face the + side up when installing a battery.
- ❑ Use the specified battery (LR44) only.
- ❑ Do not disassemble, heat, short-circuit, dispose of in fire or attempt to recharge the battery. It may explode or leak and cause personal injury.
- ❑ Keep the battery out of the reach of children. If swallowed, consult a physician immediately.
- ❑ Follow the local regulations when disposing of a used battery.
- ❑ To keep the thermometer watertight, do not damage the rubber ring or remove it from the battery compartment.

Display Mode

The thermometer has three display modes.

Displaying mode	Display example
<input type="checkbox"/> Current temperature mode Displays the current temperature.	
<input type="checkbox"/> The maximum / minimum temperature mode Displays the latest maximum and minimum temperatures that are automatically stored in the thermometer.	The maximum temperature
	The minimum temperature
<input type="checkbox"/> Automatic power-off function Turns the power off automatically after six or seven minutes of no operation.	AUTO →

Measuring The Temperature

Follow the procedure below to measure the water temperature.

1. Remove the sheath folder from the sensor sheath.
2. Press the **ON/FAST** button to turn on AD-5625.
3. Sink the sheath sensor into the liquid.
4. Press and hold the **ON/FAST** button to get the rapid response of temperature change.
5. When detecting the temperature of liquid, the thermometer displays current value. Then measurement value stabilizes.
 - If the **ON/FAST** button is not pressed and held, the display of temperature change is normal response.

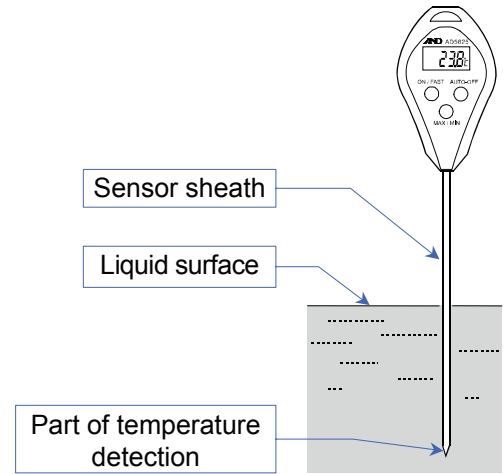

⚠ Caution

The thermometer detects the temperature at the tip of the sensor sheath. Do not expose parts of the thermometer other than the sensor sheath to the high or low temperature of the test liquid.

Recalling The Maximum And Minimum Temperatures Stored In Memory

The thermometer automatically stores the maximum and minimum temperature. They can read with the following procedure after measurements.

- With the current temperature is displayed, the maximum and minimum temperature and the current temperature are displayed in order when pressing the **MAX/MIN** button.
- Reset the memory of the maximum and minimum temperature before the measurement when using the maximum and minimum temperature in the measurement. Refer to "Resetting The Maximum And Minimum Temperatures Stored In Memory" for resting them.

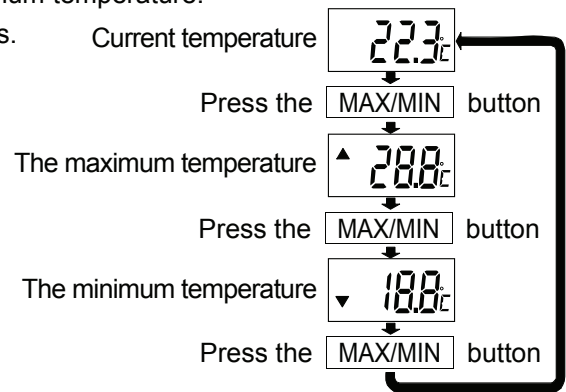

Resetting The Maximum And Minimum Temperatures Stored In Memory

The way to rest the memory of the maximum and minimum temperature is as follows:

Refer to "Recalling The Maximum And Minimum Temperatures Stored In Memory" for reading them.

□ Resetting The Maximum Temperature

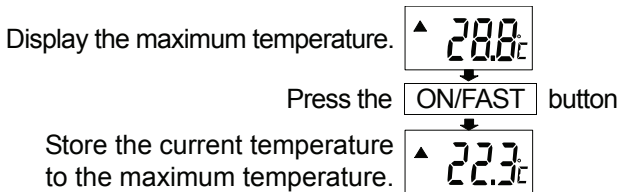

□ Resetting The Minimum Temperature

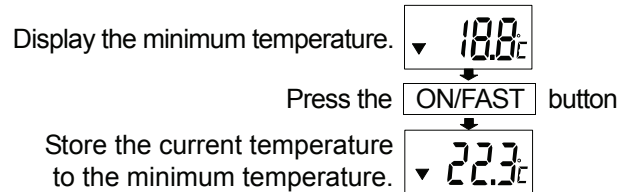

□ Returning To The Current Temperature Display

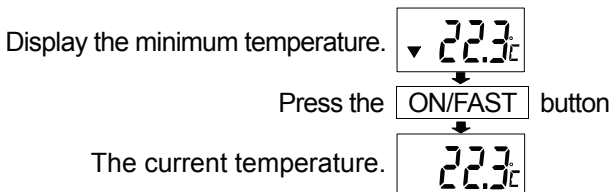

The Automatic Power-Off Function And Turing Off Thermometer

The Automatic Power-Off Function

The thermometer has an automatic power-off function. When pressing the **AUTO-OFF** button during the measurement display, the indicator "AUTO" is displayed and the automatic power-off function is performed. When no operation is performed for six or seven minutes, the thermometer is turned off automatically.

Turing Off Thermometer

When turning off the thermometer immediately from the mode displaying the indicator "AUTO", press the **AUTO-OFF** button twice.

The Way Of Use Concerning The Ring

The thermometer can hold with the ring of the sheath folder. when supporting the thermometer with the ring, insert the sensor sheath into the ring.

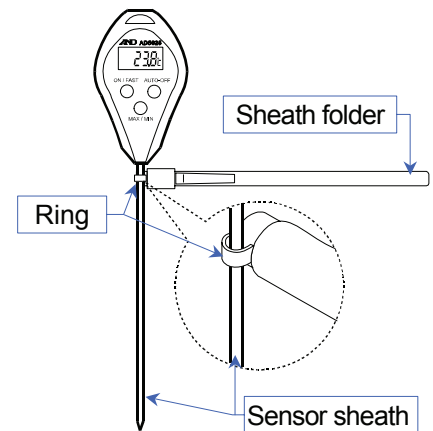

Cleaning And Keeping

Clean the sensor sheath for accurate temperature measurement and keep it.

Cleaning The Thermometer With Water

The thermometer is water-resistant type. When cleaning heavy dirt, clean the thermometer with a cloth moistened with water and a mild detergent softly.

Specifications

Sensor	: Thermistor
Measuring temperature range	: -50 to 260 °C
Display resolution	: 0.1 °C
Accuracy	: ±1.0 °C (0 to 60 °C), ±2.0 °C (-20 to 100 °C) ±2.5 °C (-50 to 100 °C), ±3.0 °C (-50 to 150 °C) ±3.5 °C (-50 to 200 °C), ±4.0 °C (other)
Sampling interval	: Regular every 10 seconds FAST every 2 seconds
Water protection	: JIS IPX7 (Endures a 30-minute immersion in a water depth of 1 meter at room temperature)
Power source, Battery life	: LR44 1piece, approx. 1 year
Operating environment	: 0 to 40 °C, 75 %RH or less, non-condensing (Excluding the sensor sheath)
Storage environment	: 0 to 50 °C, 75 %RH or less, non-condensing
Sensor sheath dimensions	: φ2.80, approx. 110 mm
Dimensions, mass	: 176 ×40 ×16 mm, approx. 25 g (including the battery and sheath protector)
Standard accessory	: This instruction manual, sheath protector, battery



A&D Company, Limited

3-23-14 Higashi-Ikebukuro, Toshima-ku, Tokyo 170-0013 JAPAN
Telephone: [81] (3) 5391-6132 Fax: [81] (3) 5391-6148

A&D ENGINEERING, INC.

1756 Automation Parkway, San Jose, California 95131 U.S.A.
Telephone: [1] (408) 263-5333 Fax: [1] (408)263-0119

A&D INSTRUMENTS LIMITED <UK Office>

Unit 24/26 Blacklands Way, Abingdon Business Park, Abingdon, Oxfordshire OX14 1DY
United Kingdom
Telephone: [44] (1235) 550420 Fax: [44] (1235) 550485

A&D INSTRUMENTS LIMITED <German Sales Office>

Große Straße 13 b 22926 Ahrensburg Deutschland
Telefon: [49] (0) 4102 459230 Telefax: [49] (0) 4102 459231

A&D Australasia Pty Ltd.

32 Dew Street, Thebarton, South Australia 5031 AUSTRALIA
Telephone: [61] (8) 8301-8100 Fax: [61] (8) 8352-7409

A&D KOREA Limited

한국에이.엔.디(주)
대한민국 서울시 영등포구 여의도동 36-2 맨하탄 빌딩 8층
(8th Floor, Manhattan Bldg. 36-2 Yoido-dong, Youngdeungpo-ku, Seoul, KOREA)
전화: [82] (2) 780-4101 팩스: [82] (2) 782-4280

A&D RUS CO., LTD.

Компания Эй энд Ди Рус
121357, Российская Федерация, г.Москва, ул. Верейская, дом 17
(Bldg. 17, Vereyskaya st., Moscow, 121357 RUSSIAN FEDERATION)
тел.: [7] (495) 937-33-44 факс: [7] (495) 937-55-66

A&D Instruments India Private Limited

ऐ&डी इन्स्ट्रूमेन्ट्स इण्डिया प्रा० लिमिटेड
509, उद्योग विहार , फेस -5, गुडगांव - 122016, हरियाणा , भारत
(509, Udyog Vihar, Phase-V, Gurgaon - 122 016, Haryana, India)
फोन : 91-124-4715555 फैक्स : 91-124-4715599