

Multi-Functional Precision Balances

GX-A / GF-A Series



GF-1003A



GF-3002A



GX-3002A



GX-1003A

Discover new ways to ensure accuracy,
durability and productivity...!



AND ...Clearly a Better Value
A&D Company, Limited
<http://www.aandd.jp>

Introducing The Next Generation Of Automated Weighing Applications

Today, it has become commonplace for materials to be weighed with automated devices. As precision balances are increasingly used in that way not just in production lines/systems but also in laboratories, users now face a range of unexpected problems.

Fact 1: Precision balances are designed to measure static loads only.

The weight sensor of a precision balance, *regardless of its manufacturer*, breaks in a short period if it is continuously affected by loads with acceleration (i.e. impact shocks). This typically occurs in factories where materials are placed roughly by machines or thrown by operators onto balances. In addition, impact shocks can easily shift values and cause errors.

The difficulty is that even if you know the above, you may not know what degree of impact shock is safe or unsafe for the balance to take necessary preventive measures such as refining the automatic loading mechanism.

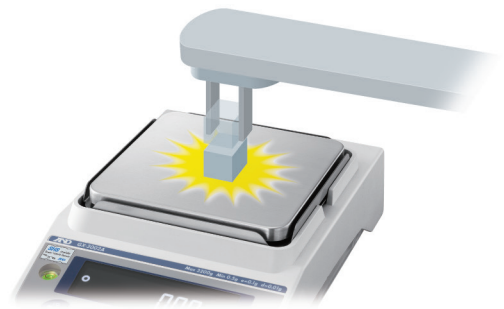

Solution: Impact Shock Detection (ISD) ♦

♦ Patented

The GX-A/GF-A series visualizes the magnitudes of impact shocks that the weight sensor receives at four levels. It beeps once at Level 3 and twice at Level 4 (both of which should be avoided).



Cushioning under the weighing pan

The two leaf springs that support the weighing pan of the GX-A/GF-A series also mitigate impact shocks significantly.

Overload protection

The weight sensor is well protected against vertical and transverse *static* overloading. It won't break due to malfunction of the weighing system's actuator and the resulting excess load. A&D's testing demonstrated that even a human did no damage to the balance by stepping on it.

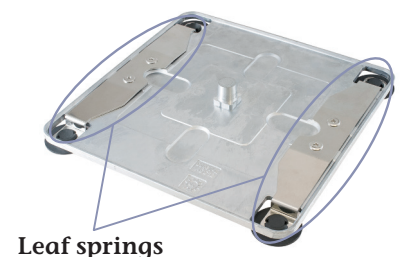

Fact 2: Precision balances are intended to be used in a stable environment.

The performance (repeatability as well as display stability) of a precision balance is worsened by external disturbances such as drafts and vibrations, which is often the case in the field. Therefore, it is strongly recommended to evaluate whether the set-up conditions are appropriate. Checking repeatability, however, is cumbersome, especially once the balance is embedded in a system. Further, it is not uncommon that users don't have an adequate test weight.

Solution: Auto Precision Assessment (APA)

The GX-A/GF-A series is designed with A&D's latest technology, Electronically Controlled Load (ECL). This technology artificially generates a minute load (0.3 to 3% of the weighing capacity) by altering the equilibrium state of the weight sensor. ♦ After making a quick diagnosis of whether there is a critical failure, the balance indicates the standard deviation (i.e. repeatability) calculated from 10 repeated measurement with ECL on the spot. The entire process takes only 1.5 minutes.

♦ Patent pending



Standard deviation calculated using ECL

Adjustable response characteristics

You can trade weighing speed for higher display stability*1 or vice versa by selecting one of three preset response characteristics (FAST, MID or SLOW).

*1 This is not to improve repeatability.

Fact 3: Internal clocks of precision balances are never in complete sync with those of external devices.

This clock time disparity manifests as a problem most noticeably when you measure and record flow rates of pumps, feeders and other devices at short intervals*2 with a balance connected to a PC that performs the calculation. The timing at which the balance receives the command from the PC to send the weight value and its display refresh cycle gradually go out of alignment. In consequence, the PC intermittently produces irregular values (spikes when graphed) even if the actual flow rate is constant.

*2 Flow rate is determined from the weight variation that occurs during a given interval.

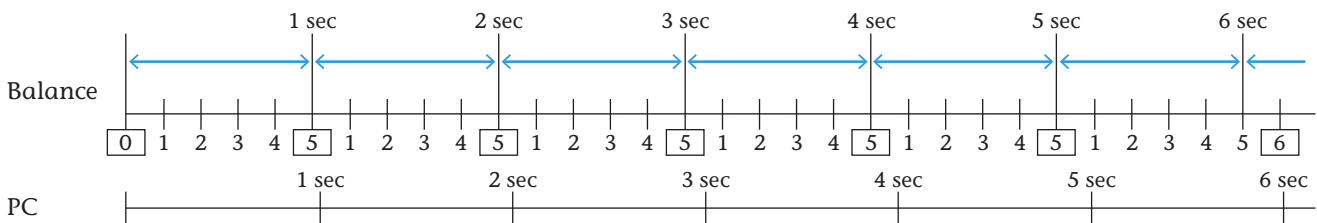

Time disparity of two different internal clocks (when the balance display refresh rate is 5 times/sec, the interval is 1 sec, and the balance's internal clock goes slightly ahead of the PC's)

Solution: Flow Rate Display (FRD)

The GX-A/GF-A series can calculate and display/output the mass flow rate (the unit of measure can be selected from g/s, g/m or g/h), or the volume flow rate (mL/s, mL/m or mL/h) by entering the density of the material. Up to 10 densities can be saved to the device. Both the display refresh rate and interval (set between 1 second and 1 hour) are regulated by the same internal clock of the balance, making measurements free from the aforementioned problem.

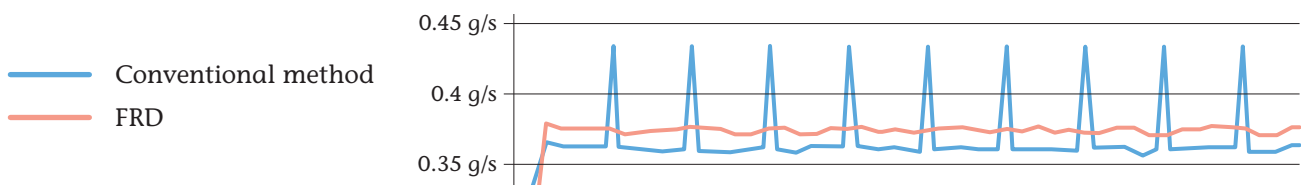

Flow rate measurement using FRD as opposed to the conventional method

Flow rate comparator

The indication allows you to monitor whether the flow rate is kept within the designated limits.

Tare memory

The tare value can be saved in non-volatile memory so that the remaining amount of the material in the container can be displayed again*³, even if power is disrupted for any reason during loss-in-weight measurement.

*³ When this function is activated, the power-on re-zero/tare is turned off.

On top of the above, the GX-A/GF-A series has many advanced and practical features and is perfect for manual weighing applications.



RS-232C and USB interfaces as standard

For the USB interface, you can toggle between the Quick USB mode (plug-and-play with weighing data output to a PC only) and the Virtual COM mode (for bi-directional communication*⁴) with internal settings. A USB cable is provided as standard.

*⁴ A special driver downloaded from the A&D website needs to be installed on the PC (except those with Windows 10).



Security slot

An off-the-shelf (such as Kensington) anti-theft lock can be used to prevent the balance from being lost.

Reverse backlit LCD display

The contrast of black and white provides excellent visibility even in poorly-lit areas and also prevents eye fatigue.



Large, easy-to-see spirit level with LED illumination

The illumination blinks for 5 seconds after the display is turned on to indicate that the balance level needs to be checked.

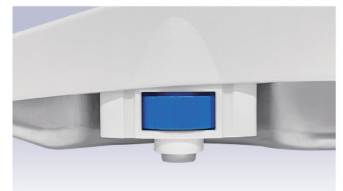

Leveling feet with thumbwheel

The leveling feet can be adjusted up or down smoothly using large thumbwheels.

Minimum weight calculation based on the APA

From the standard deviation obtained using ECL described earlier, the GX-A/GF-A series also calculates and indicates the minimum weight at the installation location*⁵ in accordance with the United States Pharmacopeia (USP) standard.

*⁵ The effects of the ambient environmental conditions on repeatability is taken into account, unlike the values shown in catalogs as "ideal" or "typical".

Minimum weight alert

To ensure that the measured sample quantity meets the minimum weight requirement, the GX-A/GF-A series can display an alert until the sample quantity reaches the value entered as the minimum weight.*⁶

*⁶ It is also possible to directly use the minimum weight determined by ECL.



Blinking minimum weight alert

User access control (UAC) and key lock for data integrity

Use of the balance can be password-protected for authorized individuals (up to 11 including one administrator)—the administrator can perform all operations including calibration while other users can make measurements only. Moreover, upon receiving a command to disable its keys, the balance becomes operable only by sending commands from an external device such as a PC.

Automatic self calibration (for the GX-A series)

The GX-A series can be set to calibrate itself automatically using its internal weight either (1) in response to change in ambient temperature (approx. 10 °C) to prevent error due to sensitivity drift, (2) at a set interval time, or (3) at predetermined (up to three) times of the day. Internal calibration can also be performed any time with one key press.

GLP/GMP/GCP/ISO compliant output

For documentation requirements, the GX-A/GF-A series can output its manufacturer, model, serial number, ID number, date + time, space for signature for calibration report, calibration test report, and title & end blocks for a series of weighing results.

Universal Flexi Coms (UFC)

UFC lets you edit serial data output/printout format. With this function, label printing is also made possible by connecting the balance to a commercially-available printer*⁷, and enabling arbitrary character strings output.

*⁷ Printers that can program printing content from the strings sent through RS-232C. Please note that a cross cable is required depending on the printer.

Gross/Net/Tare output

On receiving a command or with key operation, the GX-A/GF-A series outputs the gross, net, and tare values to an external device such as a printer, PC or PLC.

Statistical calculation function (SCF)

The GX-A/GF-A series can display and output statistical calculation data including number of data, sum, maximum, minimum, range (maximum-minimum), average, standard deviation, and coefficient of variation to facilitate the analysis of measurements.

Options

- GXA-03** 2nd RS-232C interface*8
- GXA-04** **Comparator relay output/buzzer/external key input interface*8**
Enables signaling check weighing results (5 steps) by buzzer and/or external comparator (traffic) lights. It also has two jacks for separately-sold foot switches.
- GXA-06** **Analog output interface*8**
0-1 V, or 0.2-1 V for conversion to 4-20 mA.
- FXi-08** **Ethernet interface*8**
- GXA-09** **Built-in rechargeable battery (factory-installed/dealer option) *8**
10 hours of charging for 14 hours of operation (the remaining battery level will be indicated on the display). The balance can be used while recharging the battery.
- GXA-10** **Large glass breeze break**
- GXA-12** **Animal weighing pan**
(for models of 320 g capacity or higher)
Use together with the animal weighing (average & hold) mode.
- GXA-13** **Density determination kit**
(for the 1 mg models only)
Makes weighing the sample in air and in water quicker, easier and more precise. The GX-A/GF-A series can then perform a density calculation automatically.
- GXA-17** **Large glass breeze break with built-in fanless ionizer**
(static eliminator)
The fanless ionizer can neutralize even extremely fine powders without disturbance.
- GXA-23-PRINT** **External key input interface with the AX-SW137-PRINT foot switch*8**
- GXA-23-REZERO** **External key input interface with the AX-SW137-REZERO foot switch*8**
- GXA-23-PLUG** **External key input interface with the AX-T-314A-S plug*8**
- GXA-24** **USB host interface (factory-installed/dealer option) *8**
Accepts an off-the-shelf USB flash drive to save weighing results in CSV format.
- GXA-25** **External fanless ionizer (static eliminator) *8**
Power is supplied from the balance. Activated for a set duration with an IR sensor.
- GXA-26** **External IR switch*8**
For touchless operation of print or re-zero (tare).



GXA-10 Large glass breeze break

The glass panes disappear into the back when opening the door, requiring no extra space at the rear of the balance. Easily attachable/detachable.

*8 Only one of GXA-03, GXA-04, GXA-06, FXi-08, GXA-09, GXA-23-PRINT/REZERO/PLUG, GXA-24, GXA-25 or GXA-26 can be installed.

Accessories

- AD-1641** Air flow logger
- AD-1682** Rechargeable battery unit
- AD-1683** Static eliminator*9
- AD-1684A** Electrostatic field meter
- AD-1687** Weighing environment logger
- AD-1688** Weighing data logger
- AD-1689** Tweezers for calibration weight
- AD-1691** Weighing environment analyzer
- AD-8127** Compact printer
- AD-8526** Serial/Ethernet converter
- AD-8920A** Remote display
- AD-8922A** Remote controller
- AX-GXA-31** Main unit cover (5 pcs)
- AX-SW137-PRINT** Foot switch for print
- AX-SW137-REZERO** Foot switch for re-zero
- AX-USB-9P** Serial/USB converter



AD-8127



AX-SW137-PRINT

AX-SW137-REZERO

*9 Power needs to be supplied from an AC adapter.

AD-8529PC/PR-W Bluetooth converters

Enable wireless communication between a balance/scale and a PC/printer using low-energy Bluetooth*¹⁰ (line-of-sight distance approx. 10 m when there is no radio wave interference).

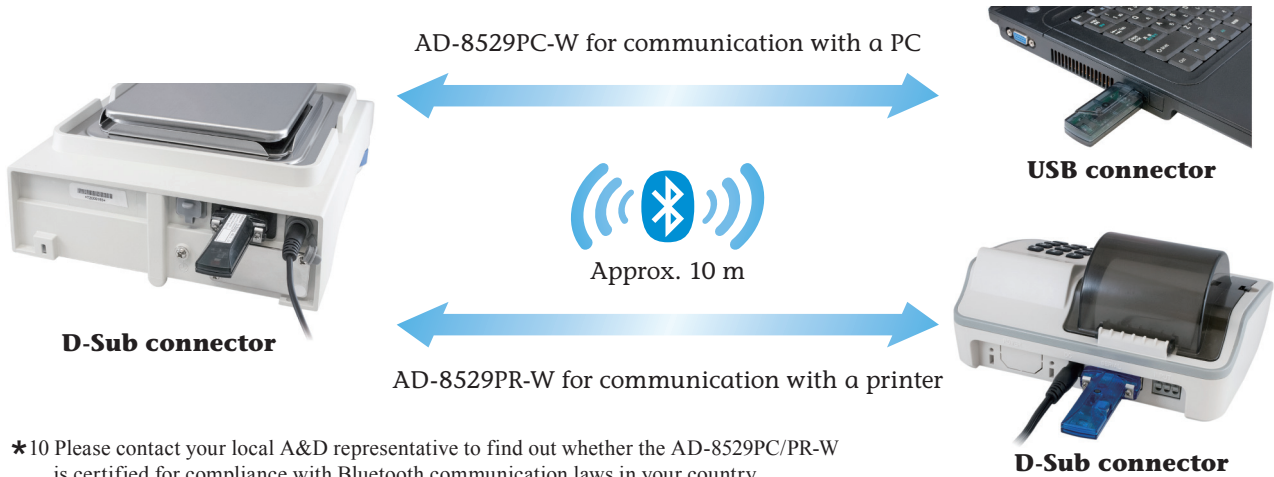

*10 Please contact your local A&D representative to find out whether the AD-8529PC/PR-W is certified for compliance with Bluetooth communication laws in your country.

Dimensions (mm/inches)

GX-203A / GX-303A / GX-403A / GX-603A /
GX-1003A / GX-1603A

GF-123A / GF-203A / GF-303A / GF-403A /
GF-603A / GF-1003A / GF-1603A

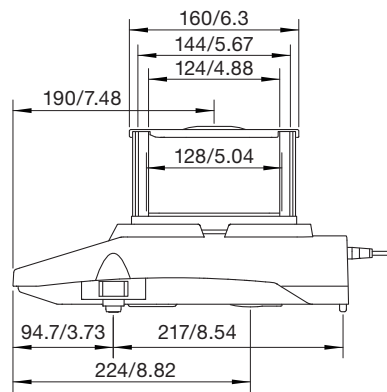
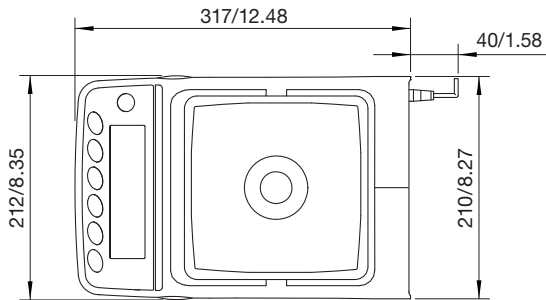
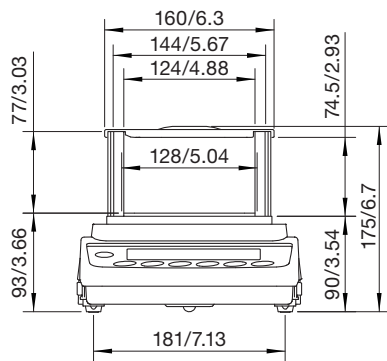

GX-2002A / GX-3002A / GX-4002A / GX-6002A /
GX-10002A

GF-1202A / GF-2002A / GF-3002A / GF-4002A /
GF-6002A / GF-10002A

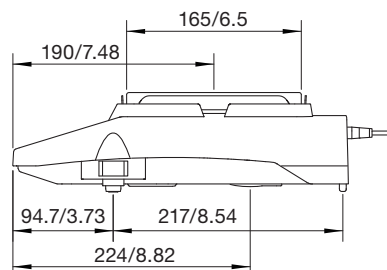
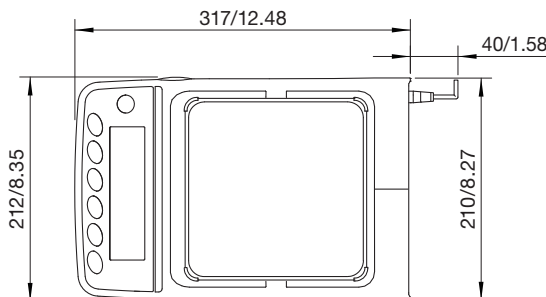
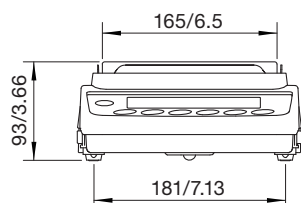

Specifications

	GX-203A		GX-303A		GX-403A		GX-603A		GX-1003A		GX-1603A	
Models	GF-123A	GF-203A	GF-303A	GF-403A	GF-603A	GF-1003A	GF-1603A					
Weighing capacity	120 g	220 g	320 g	420 g	620 g	1100 g	1620 g					
Minimum weighing value	0.001 g											
Repeatability (standard deviation)	0.001 g										0.002 g (for 1600 g)	0.001 g (for 1000 g)
Linearity	±0.002 g						±0.003 g					
Stabilization time (when set to FAST under a good environment)	Approx. 1 sec (approx. 0.8 sec for 5 g)										Approx. 1.5 sec (approx. 0.8 sec for 5 g)	
Sensitivity drift	±2 ppm/°C (10 to 30 °C/50 to 86 °F, when automatic self-calibration is OFF)											
Accuracy immediately after internal calibration (for the GX-A series) ¹	±0.010 g										±0.010 g (for 1000 g)	
Operating environment	5 to 40 °C (41 to 104 °F), 85%RH or less (no condensation)											
Display refresh rate	5 times/sec, 10 times/sec or 20 times/sec											
Units of measure ⁱⁱ	g (gram), oz (ounce), lb (pound), lb-oz (pound-ounce), ozt (troy ounce), ct (metric carat), mom (momme), dwt (pennyweight), gr (grain), pcs (counting mode), % (percent mode), SG (specific gravity), and a user-programmable unit.											
Counting mode	0.001 g											
Minimum unit mass	0.001 g											
Number of samples	5, 10, 25, 50 or 100 pieces											
Percent mode	0.100 g											
Minimum 100% reference mass	0.100 g											
Minimum 100% display	0.01%, 0.1% or 1% (depends on the reference mass stored)											
Communication interface	RS-232C and USB											
Applicable calibration weight value	50 g 100 g	50 g 100 g 200 g	50 g 100 g 200 g 300 g	50 g 100 g (100 g interval) 400 g	50 g 100 g (100 g interval) 600 g	50 g 100 g (100 g interval) 1000 g	50 g 100 g (100 g interval) 1600 g					
Weighing pan size	128 × 128 mm											
External dimensions	212(W) × 317(D) × 93(H) mm											
Net weight	Approx. 5 kg											
Power supply / consumption	AC adapter / approx. 30 VA											

	GX-2002A		GX-3002A		GX-4002A		GX-6002A		GX-10002A		GX-6001A		GX-10001A	
Models	GF-1202A	GF-2002A	GF-3002A	GF-4002A	GF-6002A	GF-10002A	GF-6001A	GF-10001A						
Weighing capacity	1200 g	2200 g	3200 g	4200 g	6200 g	10200 g	6200 g	10200 g						
Minimum weighing value	0.01 g											0.1 g		
Repeatability (standard deviation)	0.01 g						0.02 g (for 10000 g)	0.01 g (for 5000 g)	0.1 g					
Linearity	±0.02 g						±0.03 g		±0.1 g					
Stabilization time (when set to FAST under a good environment)	Approx. 1 sec (approx. 0.8 sec for 50 g)						Approx. 1.5 sec (approx. 0.8 sec for 50 g)		Approx. 1 sec (approx. 0.8 sec for 500 g)					
Sensitivity drift	±2 ppm/°C (10 to 30 °C/50 to 86 °F, when automatic self-calibration is OFF)													
Accuracy immediately after internal calibration (for the GX-A series) ¹	±0.10 g		±0.15 g		±0.15 g (for 5000 g)		±0.5 g (for 5000 g)							
Operating environment	5 to 40 °C (41 to 104 °F), 85%RH or less (no condensation)													
Display refresh rate	5 times/sec, 10 times/sec or 20 times/sec													
Units of measure ⁱⁱ	g (gram), oz (ounce), lb (pound), lb-oz (pound-ounce), ozt (troy ounce), ct (metric carat), mom (momme), dwt (pennyweight), gr (grain), pcs (counting mode), % (percent mode), SG (specific gravity), and a user-programmable unit.													
Counting mode	0.01 g													
Minimum unit mass	0.01 g													
Number of samples	5, 10, 25, 50 or 100 pieces													
Percent mode	1.00 g													
Minimum 100% reference mass	1.00 g													
Minimum 100% display	0.01%, 0.1% or 1% (depends on the reference mass stored)													
Communication interface	RS-232C and USB													
Applicable calibration weight value	500 g 1000 g	500 g 1000 g 2000 g	500 g 1000 g 2000 g 3000 g	500 g 1000 g (1000 g interval) 4000 g	500 g 1000 g (1000 g interval) 6000 g	500 g 1000 g (1000 g interval) 10000 g	500 g 1000 g (1000 g interval) 6000 g	500 g 1000 g (1000 g interval) 10000 g						
Weighing pan size	165 × 165 mm													
External dimensions	212(W) × 317(D) × 93(H) mm													
Net weight	Approx. 5 kg													
Power supply / consumption	AC adapter / approx. 30 VA													

- i Under stable environment (no rapid temperature/humidity change, vibration, draft, magnetism, static, etc). The mass of the internal weight may vary with age.
 ii One additional unit from tael (Singapore/HK jewelry/Taiwan/China), tola or Newton can be added upon request.



A&D Company, Limited
 3-23-14 Higashi-Ikebukuro, Toshima-ku, Tokyo 170-0013 JAPAN
 Telephone: [81](3) 5391-6132 Fax: [81](3) 5391-1566
 http://www.aandd.jp

A&D ENGINEERING, INC.
 1756 Automation Parkway, San Jose, CA 95131 U.S.A.
 Telephone: [1](408) 263-5333 Fax: [1](408) 263-0119

A&D Australasia Pty Ltd.
 32 Dew Street, Thebarton, South Australia 5031 AUSTRALIA
 Telephone: [61](8) 8301-8100 Fax: [61](8) 8352-7409

A&D INSTRUMENTS LTD.
 Unit 24/26 Blacklands Way Abingdon Business Park,
 Abingdon, Oxon OX14 1DY UNITED KINGDOM
 Telephone: [44](1235) 550420 Fax: [44](1235) 550485

<German Sales Office>
 Hamburger Straße 30 D-22926 Ahrensburg GERMANY
 Telephone: [49](0) 4102 459230 Fax: [49](0) 4102 459231

A&D KOREA Limited
 817, Manhattan Bldg., 33, Gukjegeumyung-ro 6-gil,
 Yeongdeungpo-gu, Seoul, 07331, KOREA
 Telephone: [82](2) 780-4101 Fax: [82](2) 782-4280

A&D RUS CO., LTD.
 Vereyskaya str. 17, Moscow, 121357 RUSSIA
 Telephone: [7] (495) 937-33-44 Fax: [7] (495) 937-55-66

A&D Instruments India Private Limited
 509 Udyog Vihar Phase V
 Gurgaon-122 016, Haryana, INDIA
 Telephone: [91](124) 471-5555 Fax: [91](124) 471-5599