



## **SYSTEM INSTALLATION MANUAL**

**Rel. 4**

© Copyright Tekmar Sistemi s.r.l.

**This document contains information, which is the property of Tekmar Sistemi S.r.l. The contents are confidential, any reproduction of all or part of this publication, without the written consent by Tekmar Sistemi s.r.l is forbidden.**

**This publication is issued to provide outline information and is not deemed to form any part of any offer and contract. The company has a policy of continuous product development and improvement and we therefore reserve the right to vary any information quoted without prior notice.**

Britecell is designed & manufactured by

**TEKMAR**  
An Allen Telecom Company

# 1. INDEX

1. INDEX .....	3
GENERAL INFORMATION .....	6
2. HOW TO READ THIS MANUAL.....	7
3. INSTALLATION & SAFETY REQUIREMENTS.....	8
3.1. Environmental conditions: .....	8
3.2. Installation site features.....	8
3.3. Power connection .....	9
3.4. Safety and precautions during the installation.....	9
3.5. Safety and precautions for lasers.....	9
3.6. Warning Labels.....	10
BRITECELL SYSTEM.....	11
4. SYSTEM DESCRIPTION .....	12
4.1. Services .....	13
4.2. Block diagram.....	13
4.3. Functional description .....	14
5. EQUIPMENT DESCRIPTION.....	15
5.1. Britecell™ subracks.....	15
5.2. Subrack modules .....	15
5.3. Remote equipment .....	16
TFL local unit .....	17
6. Introduction .....	18
7. Part description.....	18
8. Warnings .....	19
8.1. Connectors care and cleaning.....	19
8.2. Laser caution.....	19
9. Functional description.....	20
9.1. Block diagram.....	20
9.2. Down link operations .....	20
9.3. Up link operations.....	21
10. Alarms and settings .....	21
11. Installing and cabling.....	23
11.1. TPR housing.....	23
11.2. Power supply .....	23
11.3. RF inputs .....	23
11.4. Optical connections .....	24
12. Start-up .....	24
13. Troubleshooting .....	25
TFA remote unit .....	26
14. Introduction .....	27
15. Part description .....	27
16. Warnings .....	28
16.1. Connector care and cleaning .....	28
16.2. Laser caution .....	28
17. Functional description .....	29
17.1. Block diagram .....	29
17.2. Down link operation.....	29
17.3. Up link operations. ....	30
18. Alarms and settings .....	30
18.1. LED alarms .....	30
18.2. External alarms .....	30
18.3. Setting uplink gain (PGR).....	31
19. Installing and cabling.....	32

19.1.	Location.....	32
19.2.	Power supply and grounding .....	32
19.3.	RF combined ports .....	33
19.4.	Optical fibres connection.....	33
20.	Start-up .....	33
21.	Troubleshooting .....	34
TPR 19" subrack.....		35
22.	Introduction .....	36
23.	Part description .....	36
24.	Warnings .....	36
25.	Functional description .....	37
25.1.	Block diagram .....	37
26.	Alarms .....	37
27.	Installation and cabling.....	40
27.1.	Location.....	40
27.2.	Power supply .....	40
28.	Start up .....	42
29.	Troubleshooting .....	42
TFL-BSI RF attenuator .....		43
30.	Introduction .....	44
31.	Part description .....	44
32.	Warnings .....	44
33.	Functional description .....	44
33.1.	Down link operation.....	44
33.2.	Uplink operation .....	45
34.	Installation and cabling.....	45
34.1.	TPR housing.....	45
35.	Calculation of attenuation setting .....	45
35.1.	Downlink.....	45
35.2.	Uplink.....	45
TLC RF combiner - splitter.....		46
36.	Introduction .....	47
37.	Part description .....	47
38.	Functional description .....	47
39.	Warnings .....	47
40.	Installation and cabling.....	47
40.1.	TPR housing.....	47
THYB common path RF combiner .....		48
41.	Introduction .....	49
42.	Part description .....	49
43.	Functional description .....	49
44.	Warnings .....	49
45.	Installation and cabling.....	49
TFB booster .....		50
46.	Introduction .....	51
47.	Part description .....	51
48.	Warnings .....	51
49.	Functional description .....	51
49.1.	Block diagram .....	51
49.2.	Description.....	52
50.	Alarms .....	52
51.	Installation and cabling.....	52
51.1.	Location.....	52
51.2.	Power supply and grounding .....	53
51.3.	RF combined ports .....	53
52.	Start up .....	53
53.	Troubleshooting .....	54

TPA antenna .....	55
54. Introduction .....	56
55. Functional description .....	57
56. Installation and cabling .....	58
56.1. Location .....	58
56.2. Location examples .....	59
56.3. Wall mount .....	59
56.4. Connectivity .....	60
57. Troubleshooting & maintenance .....	60
SYSTEM INSTALLATION.....	61
58. Installation and cabling .....	62
58.1. Local unit and subrack location .....	62
58.2. Remote unit and antennas location.....	62
58.3. Fibre-Optic Cables .....	62
58.4. Power Supply .....	65
59. SYSTEM START-UP .....	65
60. MAINTENANCE .....	66
60.1. Plug-in cards removal .....	66
60.2. Optical equipment .....	66
OTHER INFORMATION .....	67
61. TERMINOLOGY .....	68
62. WARRANTY CONDITIONS .....	68
63. DECLARATION OF CONFORMITY .....	70
64. TECHNICAL SUPPORT .....	70
APPENDIX.....	71
65. APPENDIX A - Britecell system design basics .....	72
65.1. Indoor propagation.....	72
65.2. Fibre-optic transmission .....	73
65.3. Coverage method .....	74
66. APPENDIX B - Britecell input power level setting.....	75
66.1. Down link power levels .....	75
66.2. Down link power levels: remote unit + booster .....	76
67. APPENDIX C - Classifying hazardous areas .....	77
68. APPENDIX D - Health and safety warnings .....	78

# GENERAL INFORMATION

## 2. HOW TO READ THIS MANUAL

This manual provides equipment specifications, operational descriptions, application, and installation information as well as a troubleshooting guide. It is intended to be a comprehensive document used to install and operate a Britecell system.

The manual consists of many sections.

The first main section includes a global description of the Britecell system, major equipment warnings, warranty information, customer service and support as well as troubleshooting guidelines.

Other sections describe specific components, which are used to build or expand a Britecell system. Each section points out warnings and installation instructions.

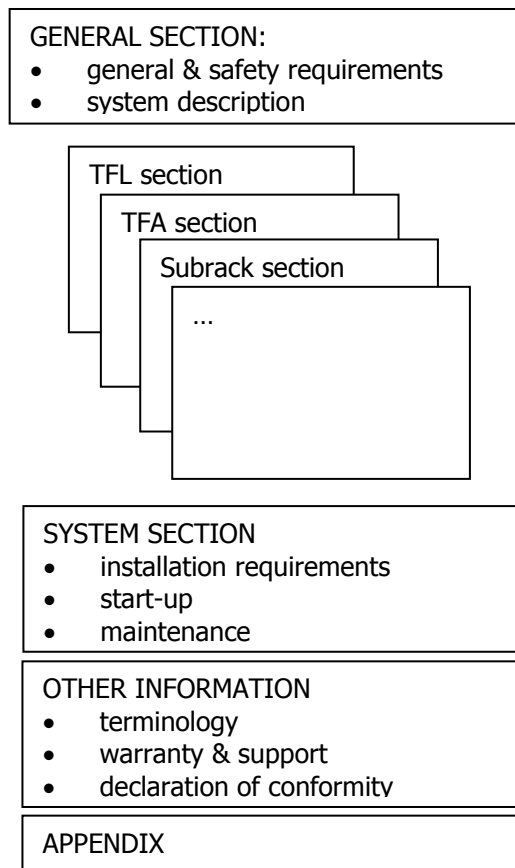

## 3. INSTALLATION & SAFETY REQUIREMENTS

### 3.1. Environmental conditions:

This equipment is designed to be installed inside buildings.

Operating temperature: +5 to +40°C

Do not install in corrosive atmosphere or in critical environmental conditions such as hazardous classified areas (for example see appendix C).

### 3.2. Installation site features

A trained technician should carry out the installation of the donor rack. Since the system is designed for indoor installation, the rack should be installed in a dry and suitable location where:

- no explosion risks is present;
- the environment is not classified as a high-risk one in case of fire;
- suspended particles are not to be found in great concentration;
- the environment is not subject to any traffic which could cause crash damages;
- the site is properly located with respect to the ergonomic positioning of the working environments;
- the system is placed in a private room, protected against any possible violation;
- the system must not be exposed to ultra-violet rays;
- the site must be accessible by maintenance personnel;
- the site must be dry, with low humidity;
- the site must guarantee proper space for cables and natural ventilation to the system;
- 2 meters must be kept from the rack to any heating opening.

The remote units should be mounted in reasonable locations as well:

- do not install inside heating or conditioning;
- do not install inside cable pipeline, fire-prevention site, (fire escape, lift tunnels, emergency exits, which have to guarantee defined safety standards);
- keep into consideration that the temperature in the upper part of a room is higher than at 2 meters height. For false ceiling installation, verify that the environment temperatures do not exceed allowed limits;
- remote unit requires its own power and a connection to the mains can be needed;
- keep into consideration that the remote unit transmits RF signal and safety volume must be respected (refer to country regulations for safety volume magnitude);
- remote units are typically installed next to the ceiling and for safety reasons they must be properly mounted;
- remote units must be accessible for tests and maintenance.



### 3.3. Power connection

Power connection has to be carried out following all the necessary precautions:

- it must be properly made according to the due diligence rules (ex.: CEI rules, IEC rules, etc.);
- in accordance with the rules for safety against direct or indirect contacts;
- in accordance with the rules for safety against the over current (short circuit, overloading);
- in accordance with the rules for safety against over tension;
- connection is to be carried out by proper and competent staff

### 3.4. Safety and precautions during the installation

During installation the following means and tools will be needed:

**Typical electrician tools:**

cross-point screwdriver, scissors, pliers, nippers, drill and bits, screw for fixing remote units to the wall.

**Typical means:**

proper ladder, scaffolding or air platform for ceiling installation of remote units.

- ✓ *N.B: cautions should be used when installing at a height upper than 2 meters. Personnel who are installing this equipment should be informed about the possible risks and safety measures when elevated.*

### 3.5. Safety and precautions for lasers

The laser used in Britecell contains an optical transmitter, which has a power level that is not dangerous to a person's health. However it is classified as class III B (norm EN60825) equipment. It is nevertheless prudent in the installation phase to observe the following rules:

- ✓ *Never look directly at the internal optic connector exit of the transmitter apparatus when it is switched on. The wavelength of the laser is not visible to the human eye, which means that long-term damage will not immediately be known.*
- ✓ *When working with the optical connectors, check at each end that both transmitting lasers are switched off.*

### 3.6. Warning Labels



**Caution!** - invisible laser radiation from this aperture



**Caution!** - Laser radiation. Do not stare into the beam or view directly with optical instruments – CLASS 3A laser product



**Caution!** - angled polished connector



**Caution!** - invisible laser radiation from this aperture – angle polished connectors



**Caution!** - possible invisible laser radiation, max. power 30mW, wavelength 1300nm, laser product CLASS III B

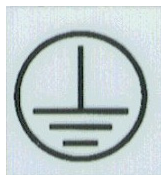

**GROUND** - Use this terminal for a safety ground connection of the equipment.

# BRITECELL SYSTEM

## 4. SYSTEM DESCRIPTION

Britecell is a low power distribution system designed to provide indoor coverage for mobile communication networks.

.The whole system is based on the fiberoptic transmission of multiple RF carriers from an optical donor unit interfacing to the BTSs (TFL) and an optical remote unit located in remote sites (TFA) near an antenna.

The transmission of the uplink and downlink RF signals is attained by using bi-directional fiberoptic links. Furthermore it is possible to reach and feed multiple remote antennas by distributing a number of fiberoptic links in a star configuration.

The system has been designed to make use of the concept of "low power distributed antenna system" (DAS). The premise of the DAS system is to achieve good link quality through the use of many lower power radiating points (fed by TFAs).

The advantage of this system is lower costs and higher reliability. This is possible because high power amplifiers are both costly and less reliable than low power devices.

Britecell is very simply and including a built-in AGC. As such it requires a minimum design, installation and set-up effort, in contrast with a comparable active cable systems, which require considerable uplink and downlink design and optimisation.

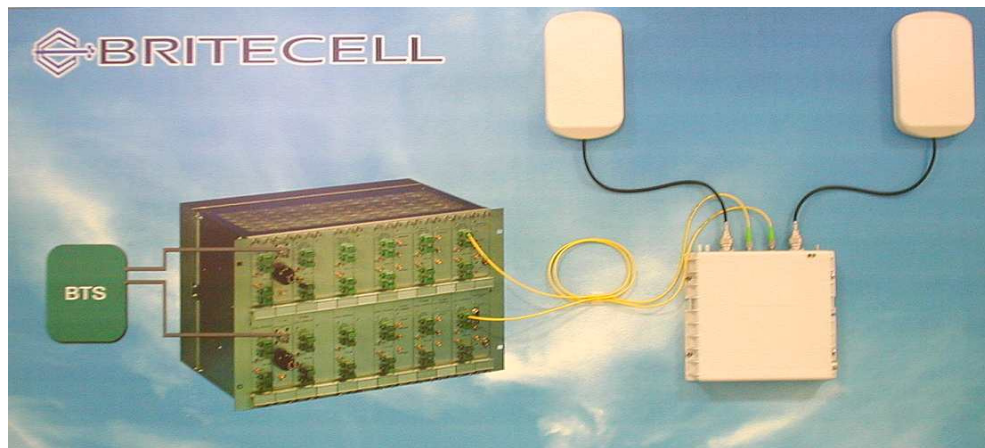

**The system.**

**A rack complete with 6 donor units (TFLs), a remote unit (TFA) and two antennas**

## 4.1. Services

The Britecell system can operate with single band or dual-band. The following is a list of possible standards with related frequencies:

FREQUENCY OPTIONS		BANDWIDTH [MHz]		
		<i>uplink</i>	<i>downlink</i>	
UHF	GSM900+GSM1800	406:512	406:512	
VHF paging	GSM900+PCS	---	270:290	
TRUNKING RADIO	AMPS+PCS	805:825	850:870	
AMPS	AMPS+DCS	810:830	940:960	
GSM900	TRUNKING+PCS	824:849	869:894	
PDC1500	E-GSM+GSM1800	880:915	925:960	
GSM1800	E-GSM+PCS	890:915	935:960	
PCS	UMTS (UTRA FDD)	1429:1453	1477:1501	
E-GSM		1710:1785	1805:1880	
		1850:1910	1930:1990	
		1920:1980	2110:2170	

Tab. 1 - services

## 4.2. Block diagram

This is a basic system configuration. The overall system design and coverage project may need different architectures, and different ancillary configurations.

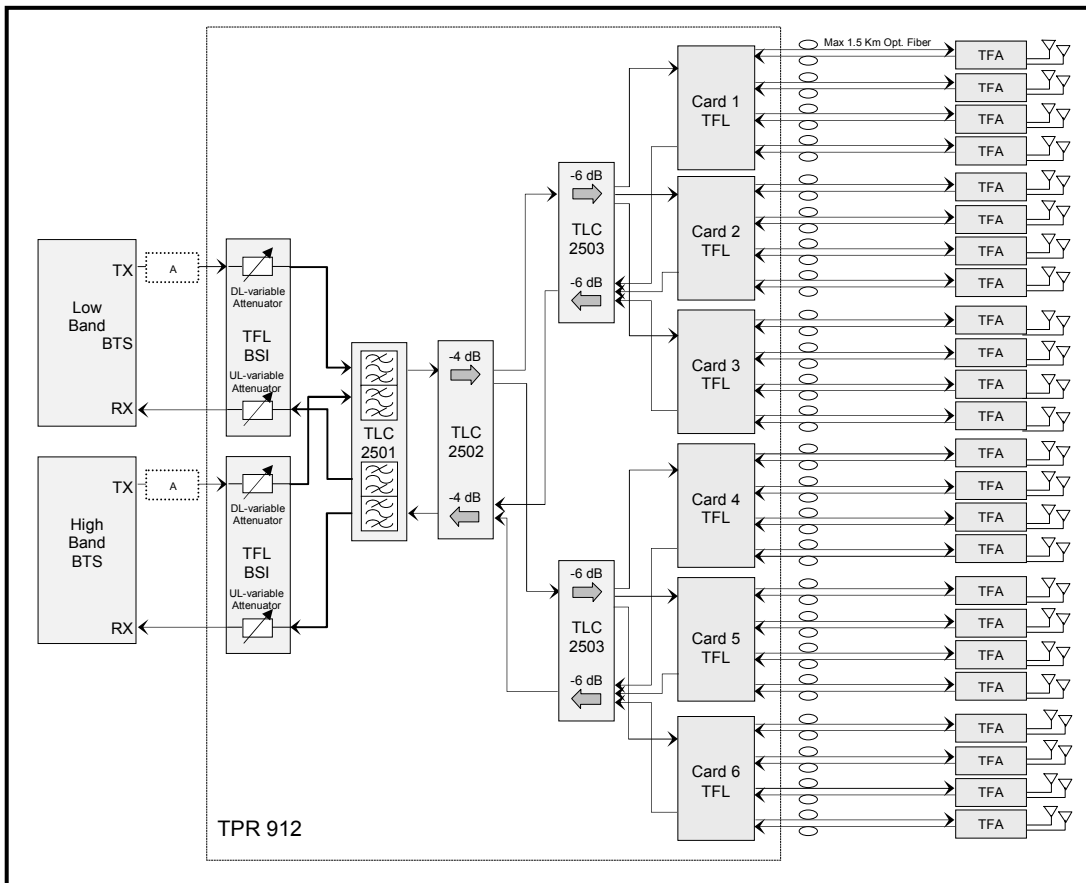

Fig. 2 - Block diagram

### 4.3. Functional description

The basic system blocks are the fiber donor unit TFL (Local Unit) and the fiber remote unit TFA (Remote Unit).

They are connected in both directions (uplink and downlink) through single mode optical fibre.

The system has a built-in Automatic Gain Control (AGC), which automatically adjust the up link and down link gain in order to compensate for optical link loss<sup>1</sup>.

This allows the downlink transmit power and the up link sensitivity to be virtually independent on fibre length and on the number of splices or optical connectors present along the fibre link.

Each Local unit can support and constantly monitor up to 4 remote units.

Moreover up to 6 central units can be housed, together with power supply, in the same subrack 19".

The TFA feeds up to two coverage antennas. In this way it is possible to set up a network of 24 transceivers and up to 48 coverage antennae (see Fig.2).

The connection between the BTS and Britecell system can either be direct or, through a repeater.

In Fig. 1, a typical direct connection to BTS is showed for a dual band system. The building blocks of the combining network are:

- two/three way combiners and splitters (TLC2502/3);
- cross-band couplers (TLC2501);
- variable attenuators (TFL-BSI).

The combining network has to be carefully designed in order to optimise the connection to the BTS and the system performances.

---

<sup>1</sup> provided that the specified limits are not exceeded (please refer to datasheets)

## 5. EQUIPMENT DESCRIPTION

Britecell is a modular system. Many options and accessories are available, depending on the desired coverage area. The following is a list of main accessories, suitable for most applications.

### 5.1. Britecell™ subracks

The Local Units are located inside a 19" 6HE sub-rack. From this rack, power is supplied for the all fibre donor units (TFL).

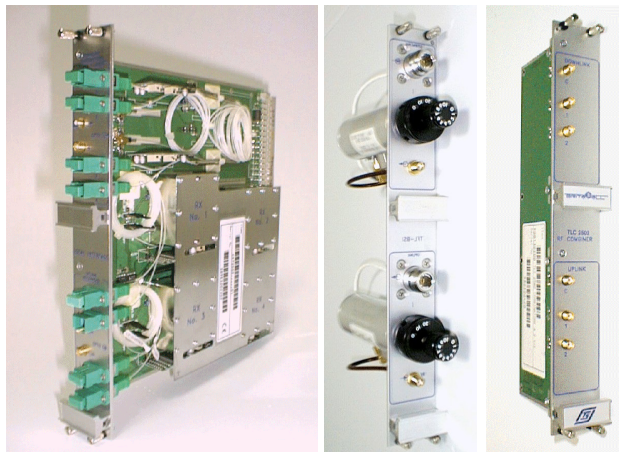

Fig. 3 – 19" sub-rack

Subrack can be supplied by a -48V DC or by universal mains (85-264VAC). See datasheets for further details.

Power switches and fuses are placed on subrack back panel (see TPR section below).

### 5.2. Subrack modules



TFL - LOCAL UNIT

TFL-BSI

TLC2502

- TFL is the RF to optical converter.
- TFL-BSI is a variable RF attenuator (0-30dB)
- TLC2502 and TLC2503 are RF splitters/combiners

### 5.3. Remote equipment



**Fig. 4 - TFA remote unit  
remote antenna**

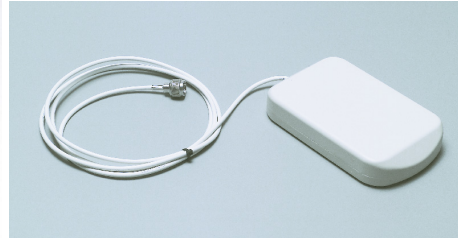

**Fig. 5 - TPAxxx -  
remote antenna**



**Fig. 6 - TFB - RF booster**

TFA is the optical to RF converter.

TPA is the suggested indoor antenna family.

TFB is the RF booster if needed to extend the coverage area.

TFA can feed up to two antennas while TFB can be connected to one antenna.

Detailed descriptions of these components are available in the sections below.



TFL local unit

## 6. Introduction

This section describes the TFL (Local Unit). The TFL is the part of Britecell system that provides E/O downlink conversion and O/E uplink conversion of RF signal.

The TFL is connected to remote TFA by means of two optical fibres.

The system forms a star configuration. One fibre is dedicated to the transmission of the downlink signals received from BTS and re-transmitted to the mobile. The other fibre supports the transmission of up-link signals, received from mobile through the TFA remote units and destined for the BTS.

The TFL cards are 6HE plug-in modules and are contained in a standard 19" subrack (TPR family).

## 7. Part description

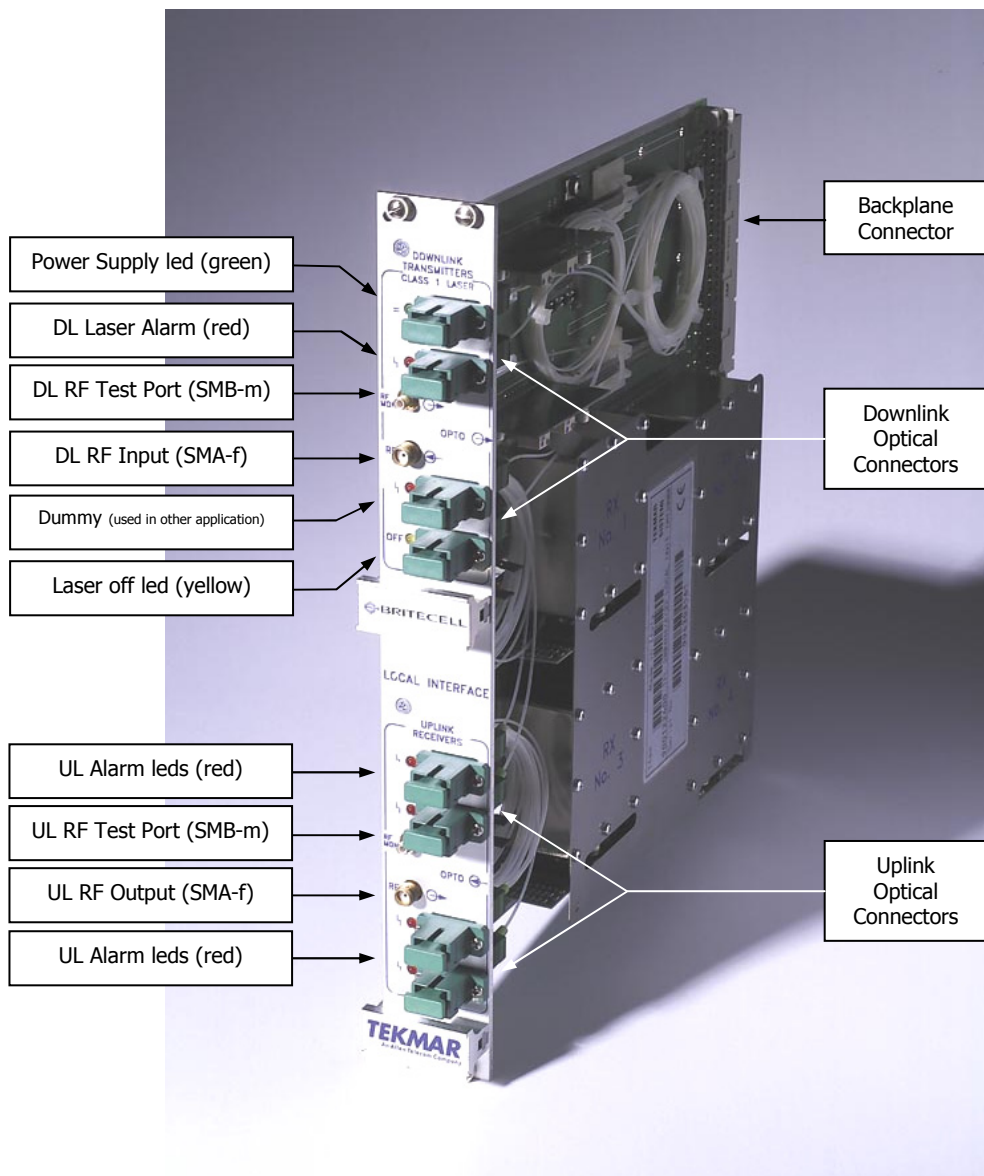

## 8. Warnings

- ✓ *CAUTION! do not remove or insert any module into TPR subrack, without prior switching power supply off.*

### 8.1. Connectors care and cleaning

Optical connectors for single mode fibers are designed for submicron tolerances. Such a connector has an optical section of only 9  $\mu\text{m}$  diameter. The rules below must be carefully followed

- ✓ *Do not leave optical connectors open, as they will attract dirt.*
- ✓ *Do not touch the connector tip. Clean it with a proper tissue before inserting it into the sleeve.*

If a better cleaning is needed, use pure ethyl alcohol. Sleeves may be cleaned by injecting pure gas under pressure.

- ✓ *Do not attempt to insert connectors mechanically incompatible. This will result in severe damage.*

The optical connector is a high precision device. It must be handled with care, to avoid scratches and other mechanical/optical damages that will impair or reduce the system's performance.

### 8.2. Laser caution

The TFL contains semiconductor lasers. Precautions should be taken when handling, installing or servicing this equipment.

Invisible laser radiation may be emitted from the optical transmitter orifice at the TFL local interface:

- ✓ *Do not stare into the beam or use optical instruments with powered equipment.*

## 9. Functional description

### 9.1. Block diagram

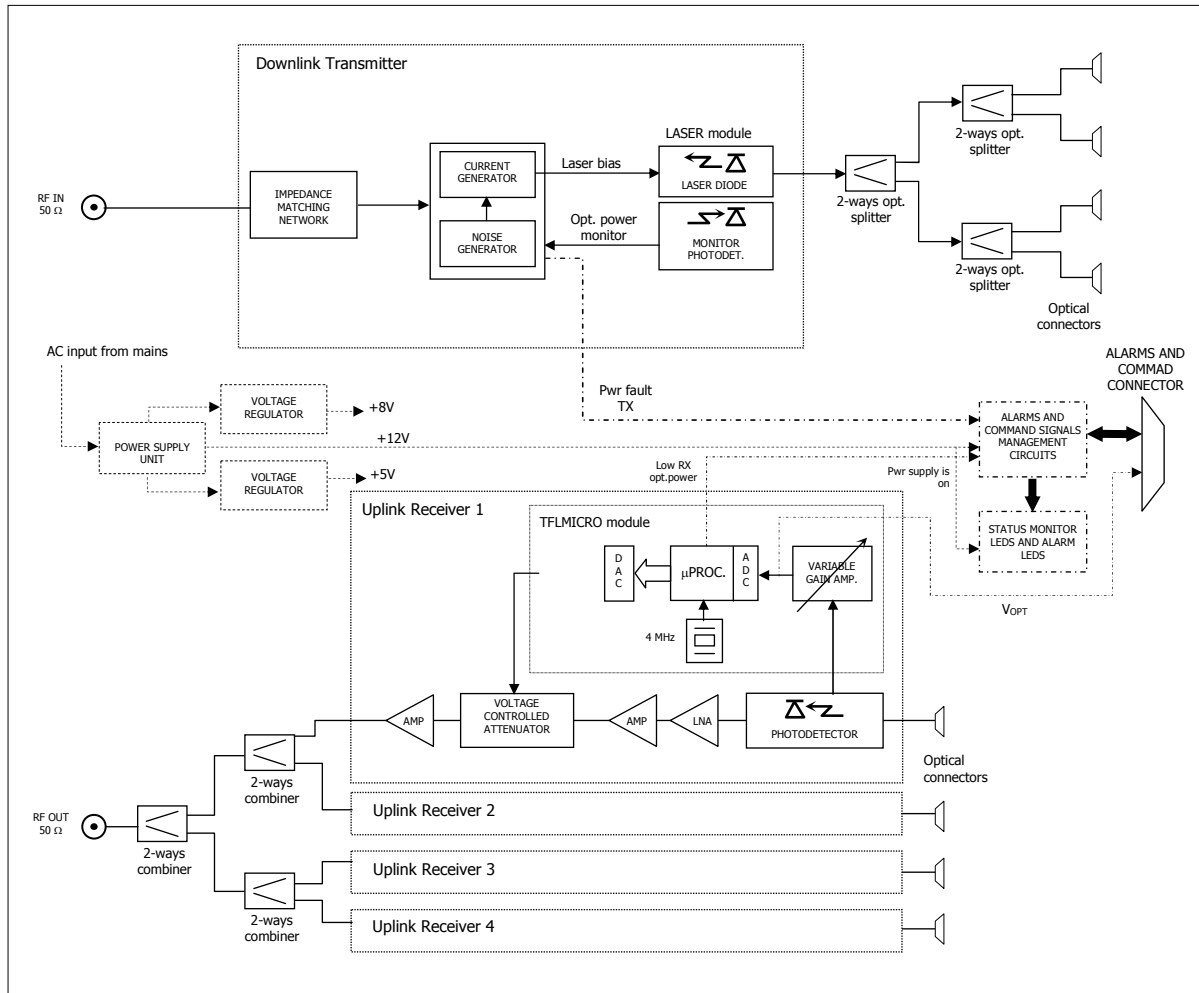

Fig. 8 - block diagram

### 9.2. Down link operations

In down link the TFL fulfils the following operations:

#### Power level adjustment:

if the RF signal coming from the BTS has a power level which is not adequate to TFL's characteristics, an external adjustment is required. It consists in an attenuation when BTS is connected through a coupler or through repeater (please refer to TFL-BSI).

#### E/O Conversion:

RF signal modulates the intensity of an optical carrier through an electro-optic device (laser). One laser is present on each TFL card.

#### Optical Splitting:

modulated optical carrier is split into 4 ways so that it may be transmitted on a maximum of 4 optical links.

### 9.3. Up link operations

In uplink, signals pass through a duplexer and are then subjected to the following operations:

O/E Conversion:

there are 4 O/E conversion devices (or optical receivers) in one TFL (one for each optical link).

Amplification:

amplification is needed to compensate the optical fibre loss (maintaining a good signal to noise ratio) so that for each link a constant gain is obtained.

RF Combining:

signals coming from all the remotes are combined into a single RF port.

Power level Adjustment:

TFL output may need a level adjustment so that the RF signals are within the optimum BTS receiving range (please refer to TFL-BSI).

## 10. Alarms and settings

Two types of local alarm are available:

Visual alarms:

the front panel of a TFL Local Unit shows the following status for alarm LEDs:

Link	LED	Colour	Meaning (when lit)
Downlink Transmitter	=	Green	Laser is biased
	⌋	Red	Laser optical power under limits and/or bias is not present.
	OFF	Yellow	Laser has shutdown command.
Uplink receivers	⌋	Red	Input optical power is lower than pre-set.

**Tab. 2 -Alarm LEDs**

Relay logic alarms detectable on connector:

in the rear of TFL units an alarm interface connector passes information about summary alarms and specific alarms which can be sent to an OMC (Operating and Maintenance Centre) via the BTS. In addition the alarms may be monitored from Britecell's own OMC (please refer to TPR).

Settings:

No adjustments are required at local interface module.

Four optical receivers are present at each TFL.

Unused receivers may cause uplink alarms if enabled. In order to avoid UL alarms unused receivers must be turned off. This can be done simply changing jumper position as shown on Fig. 9 and Fig. 10 .

Tab. 3 is a chart of the correct jumper positions.

Each receiver has a number silk screen printed on the metal protection, which corresponds to the relevant UL optical port on the TFL front panel.

The jumper number and relevant receiver status are printed on TFA main board, so that the operation results very simple.

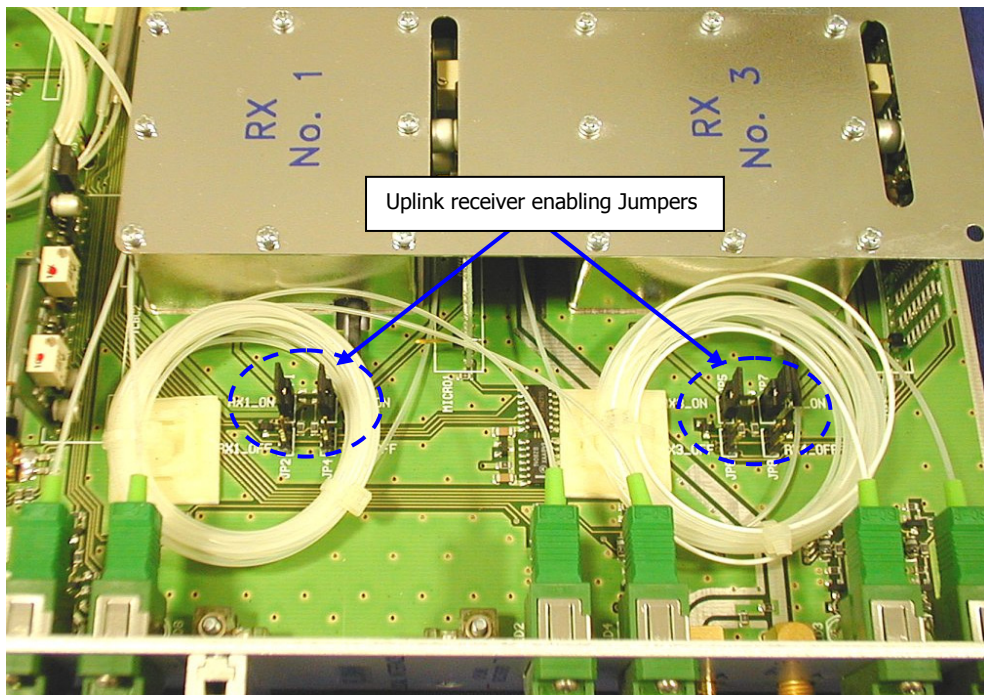

**Fig. 9- Uplink jumpers**

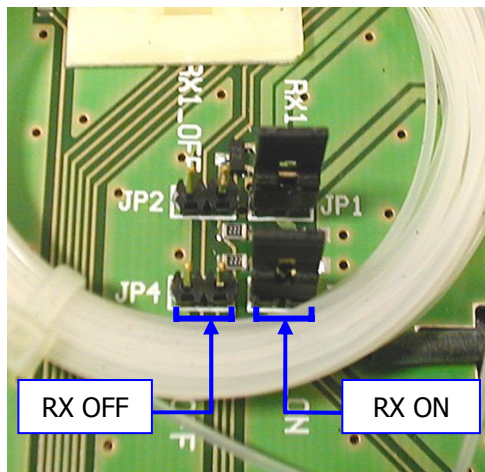

**Fig. 10- Uplink jumper positions**

Receiver	Status	Jumper position
RX No.1	ON	JP1
	OFF	JP2
RX No.2	ON	JP3
	OFF	JP4
RX No.3	ON	JP5
	OFF	JP6
RX No.4	ON	JP7
	OFF	JP8

**Tab. 3 - Jumper positions**

## 11. Installing and cabling

### 11.1. TPR housing

The TFL modules are contained in a 6 HE sub-rack (TPR family). The local interfaces cannot be placed next to each other.

The TFL local interface cards may only be fitted in slots 1, 3, 5, 7, 9, and 11 of the sub-rack.



Fig. 11 - Subrack slots



Fig. 12- Dummy plug

If any slots are unused the backplane connectors must be fitted with a dummy plug (provided) to avoid alarms being generated (see Fig.15).

Installation of Local Interface should be implemented in accordance with standard rules related to fixed base equipment.

- ✓ *WARNING: prior to removing or inserting any modules, make sure that the power supply is off.*
- ✓ *WARNING: the TFL cards must be handled with care in order to avoid damages to electrostatic sensitive devices.*

Should a Local Unit need to be removed, first remove the left adjacent module.

The sub-rack housing if correctly installed (see TPR section) provides also the proper air circulation to the Local Unit.

### 11.2. Power supply

TFL cards are powered by the proprietary backplane (Sub-rack TPR family), power consumption is 12W for each TFL.

### 11.3. RF inputs

The RF combining and interface section, if properly designed, provides the right power levels to the TFL.

- ✓ *WARNING: Do not exceed the maximum RF level allowed for downlink input (see TFL datasheets). Please refer to the system design for variable attenuator settings (see system start-up section)*

### 11.4. Optical connections

Optical connectors are designed to have proper alignment and mechanical support. When inserting an optical connector, take care to handle it smoothly enough so as not to damage the fibre.

Fasten the fibre cable to the provided seating base by means of the included wrapper.

Remove the dust cap only immediately before making connections.

- ✓ Do not force or stretch the fibre pigtail with curve radius less than 5 cm. See Fig. 13 for optimal fibre cabling.

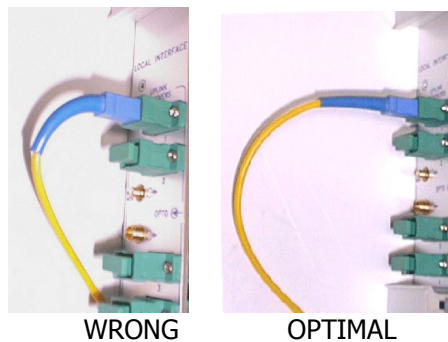

Fig. 13 – Fibre connection

## 12. Start-up

A preliminary verification of TFL correct operation is:

1. switch-on the TPR subrack
2. verify the following LED status

Link	LED	Colour	Status
Downlink Transmitter	=	Green	ON
	⌋	Red	OFF
	OFF	Yellow	OFF
Uplink receivers	⌋	Red	Depending upon TFA status, always off if receiver alarm disabled

For a full functionality test please refer to the system start-up section.



## 13. Troubleshooting

Correct alarm interpretation is very useful not only during the installation, but also during maintenance

### TFL laser failure:

replace the faulty transmitter by replacing the TFL unit with a new one.

### RX alarm only:

first go to the TFL site and check if optical connectors of TFL are properly cleaned.

If the problem still exists, go to the TFA site (the TFA which yields also visual RX alarm at TFL). If the TFA shows a visual alarm, clean the downlink optical connector.

If the TFA is still alarmed, measure the downlink optical power at TFA input with an optical power meter and verify if it is higher than  $-5$  dBm. If it is not, the fibre cable (at least as far as the downlink fibre is concerned) has some problems. If optical power is higher than  $-5$  dBm, replace the TFA.

TFA remote unit

## 14. Introduction

This section describes the TFA (Remote Unit).

The TFA is part of the Britecell system and provides O/E downlink conversion and E/O uplink conversion.

The TFA is connected to passive antennas, which transmit and receive from and to the mobiles.

Each TFA is connected to a TFL through two optical fibres.

This forms a star configuration. One fibre is dedicated to the reception of the downlink signals that the TFA receives from TFL, and re-transmits to mobile stations. The other fibre supports the transmission of uplink signals, which each TFA gathers from the mobiles operating in its coverage area, to the TFL.

TFA can feed antennas through two external RF ports, except UMTS TFA where a single RF TRx port is provided.

## 15. Part description

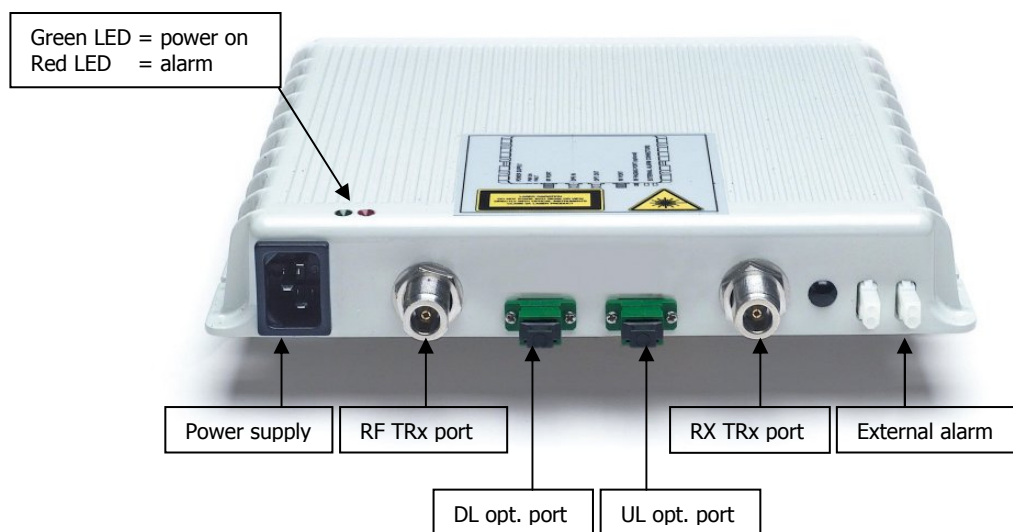

**Fig. 14 – TFA Remote Unit part description**

## 16. Warnings

### 16.1. Connector care and cleaning

- ✓ *Do not leave connectors open. Unused optical connectors must always be covered with their caps.*
- ✓ *Do not touch the connector tip. Clean it with proper tissue before inserting them into the sleeve.*

If better cleaning is needed, use pure ethyl alcohol. Sleeves may be cleaned by injecting pure gas under pressure.

- ✓ *Do not attempt to insert connectors mechanically incompatible. This will result in severe damage.*

The optical connector is a high precision device. It must be handled with care to avoid scratches and other mechanical/optical damages that will impair or reduce the system performance.

### 16.2. Laser caution

The TFA contains semiconductor lasers. Precautions should be taken when handling, installing or servicing this equipment.

Invisible laser radiation may be emitted from the optical transmitter connector of the TFA interface:

- ✓ *Do not stare into the beam or use optical instruments with the equipment powered on.*

## 17. Functional description

### 17.1. Block diagram

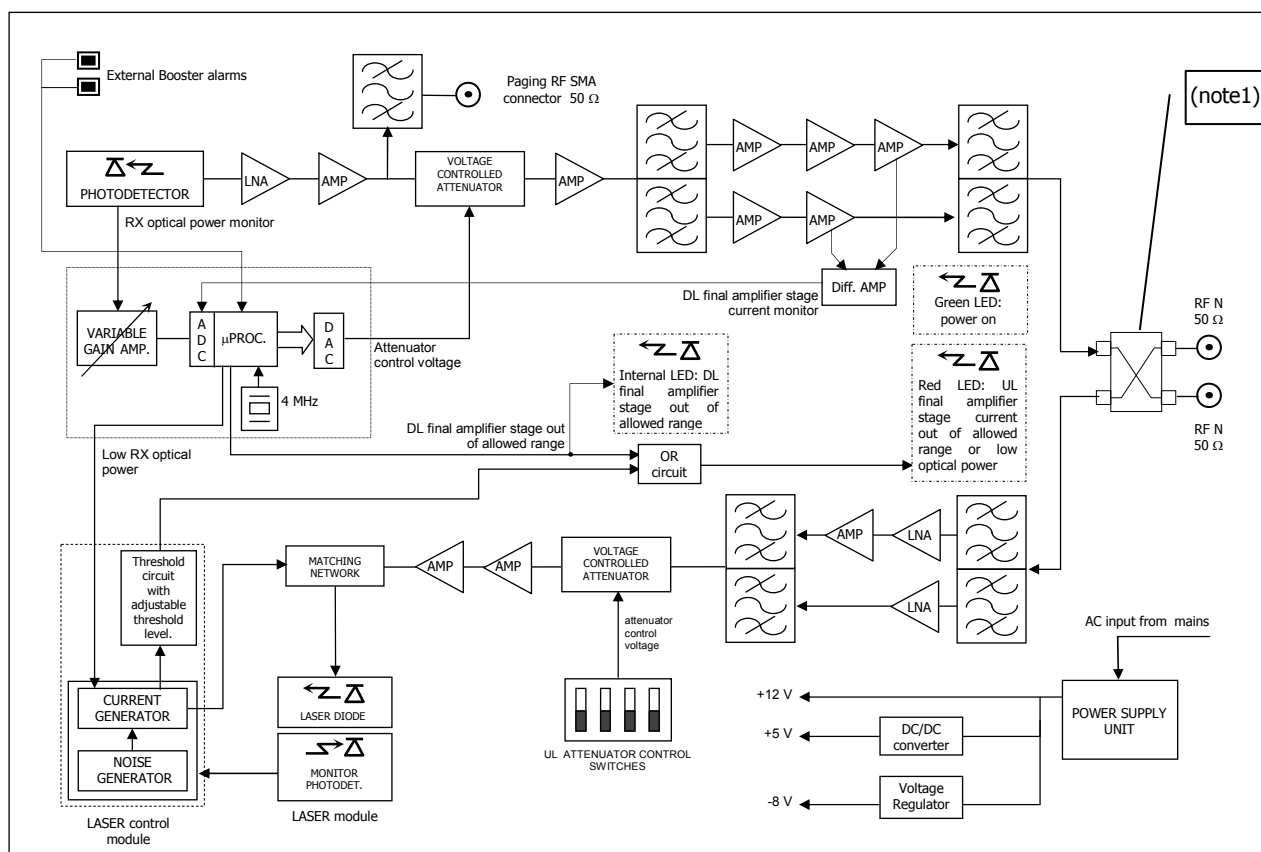

Fig. 15 – TFA block diagram

Note 1: not present in UHF TDD version

### 17.2. Down link operation

In the downlink the TFA fulfils the following operations:

#### O/E Conversion:

the optical signal is demodulated through an opto-electronic device (p-i-n photodiode).

#### Amplification & Filtering:

amplification is required to boost the downlink signal after is converted from light back to RF. Maintaining a good signal-to-noise ratio is critical for this operation; part of the amplification process automatically takes into account the variable loss introduced by the optical fibre.

A clean-up filter is used after the amplification process to limit transmission to the downlink band and to reduce spurious emissions in the uplink band where they would interfere with the signal coming from the mobile.

#### Duplexing:

the RF signal enters a duplexer which combines downlink and uplink on a single port which is then split and goes to two separate antenna ports.

### 17.3. Up link operations.

In the uplink the TFA performs the following functions:

Filtering & Amplification:

a filter delimits the uplink band and a low noise amplifier increases the signal level to minimise the noise figure of the link.

E/O Conversion:

the RF signal coming from the antennas modulates the intensity of an optical carrier through a laser.

## 18. Alarms and settings

### 18.1. LED alarms

For TFA units only visual alarms are provided. Two LEDs represent them:

LED	Colour	Meaning (when lit)
LD1	Red	No optical power at DL input and/or amplifier failure
LD2	Green	Power supply is on

Tab. 4 – TFA Alarm LEDs

*NOTE:* the uplink laser is on only if downlink optical signal is present and no failure occurs in the TFA; in case of any failure, the uplink laser is switched off.

It is useful to note that as a downlink failure will be reported to both TFL a TFA, it is possible to determine a fibre or TFA failure from either the TFA or TFL.

This information can be used in conjunction to others for troubleshooting (see par.21).

### 18.2. External alarms

TFA is provided with two external alarm contacts.

These contacts are open under non-alarm condition (normally open).



Fig. 16 - External alarms (dry contacts)

### 18.3. Setting uplink gain (PGR)

To optimise system performances related to “blocking level” (refer to system design for further details), TFA units shall include an RF uplink attenuator to adjust the uplink gain (Pre-settable Gain Reduction – PGR).

Up link gain setting can be easily executed removing the rear lid (see Fig. 17) and setting SW1 bits (see Fig. 18) according to Tab. 5.

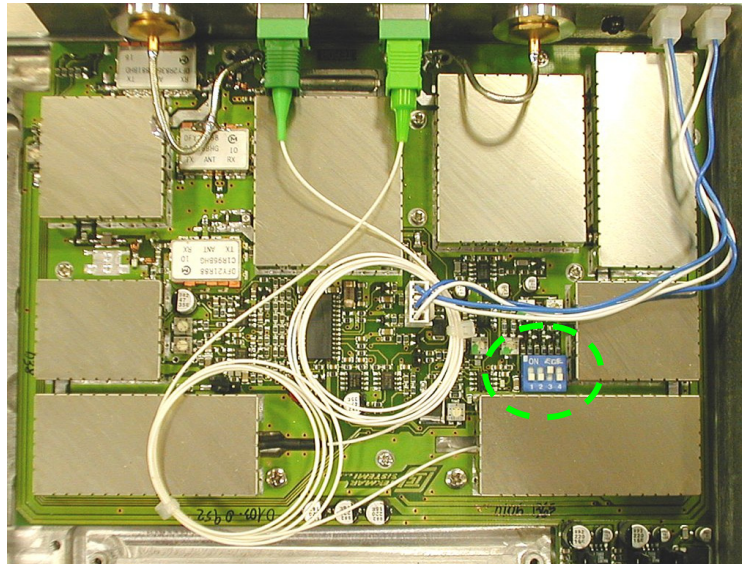

Fig. 17 – TFA PGR dip- switches

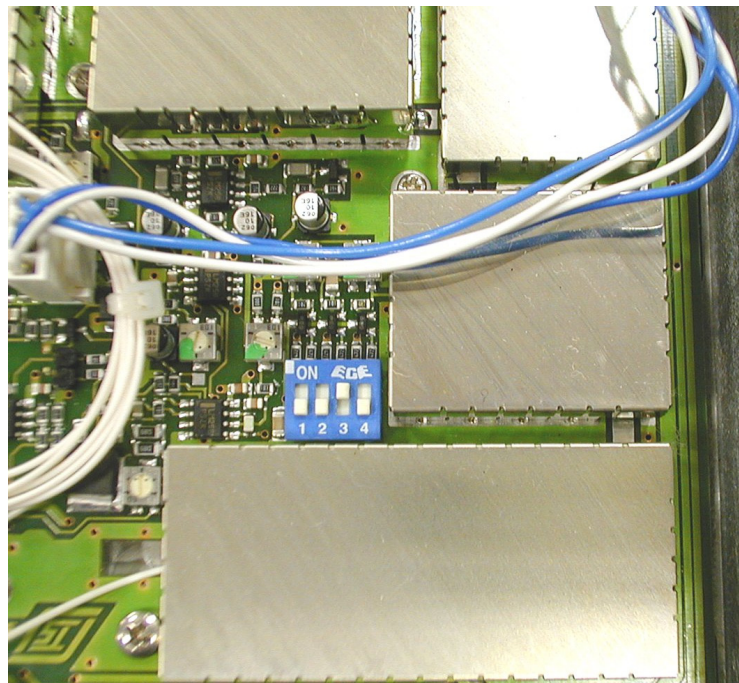

Fig. 18 – Dip-switches settings

Gain Reduction	bit 1	bit 2	bit 3	bit 4
0 dB	OFF	OFF	<b>ON</b>	OFF
5 dB	OFF	<b>ON</b>	OFF	OFF
10 dB	<b>ON</b>	OFF	OFF	OFF

Tab. 5 - Uplink gain reduction settings

## 19. Installing and cabling

### 19.1. Location

TFA units shall be installed as close as possible to the radiating antennas, so as to minimise coaxial cable length and reduce downlink power loss and uplink noise figure.

However, the units should be installed no closer than 2.5 m to the closest mobiles approach to avoid blocking. If remote units need to be installed very close to where mobiles are, the internal variable attenuator should be used.

The TFA is intended to be installed on walls, false ceilings or other flat surfaces. A mounting bracket is available for easy mounting.

Proper installation of the TFA is required for optimal performance. Take care to install the TFAs "warm side out" as indicated in Fig. 14 The positioning of the unit and the cables is important so as to avoid accidental damage.

### 19.2. Power supply and grounding

#### 19.2.1. Universal mains (85-264VAC, 50/60Hz)

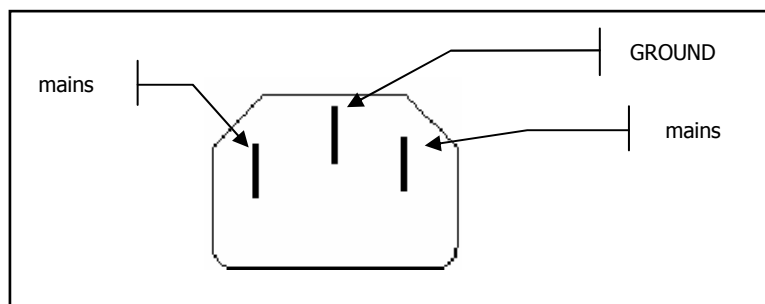

Fig. 19 -Mains connector

#### 19.2.2. DC negative supply -72 to -36 VDC.

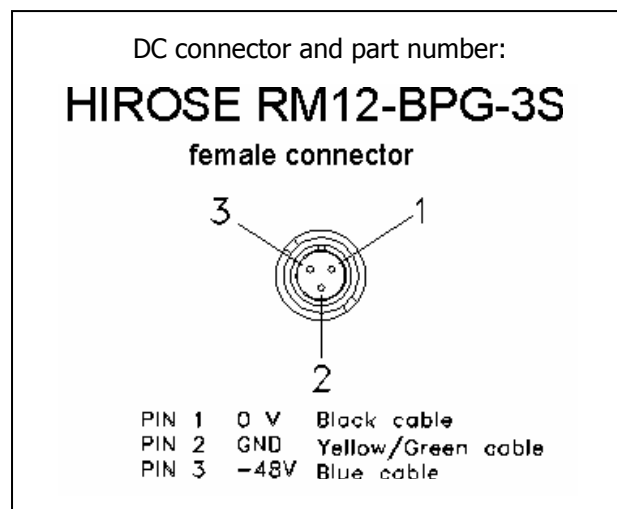

Fig. 20 - VDC connector



### 19.3. RF combined ports

These ports should be directly connected to the radiating antennas through RF jumper cables.

Unused RF output ports must be terminated with a dummy 50Ω load. Optional boosters (TFB family) also can be connected to one or both of the combined ports for additional RF downlink power.

### 19.4. Optical fibres connection

Optical connectors need to have proper alignment and mechanical support. When inserting an optical connector, take care to handle it smoothly enough so as not to damage the fibre. Remove the dust cap only immediately before making connections.

- ✓ Do not force or stretch the fibre pigtail with curve radius less than 5 cm. See Fig. 21 for optimal fibre cabling.



WRONG

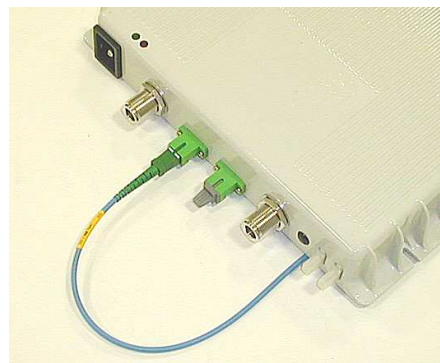

OPTIMAL

Fig. 21 - Fibre connection

## 20. Start-up

To perform a preliminary verification of the TFA:

- power-up the TPA;
- verify the following LED status:

LED	Colour	Status
LD1	Red	OFF if optical received power above lower required limit and internal operations ok
LD2	Green	ON

For a full functionality test please refer to the system start-up section.

## 21. Troubleshooting

If an alarm LED is active, check the environmental conditions (operating temperature, supply range, etc.).

If an alarm persists, it is essential to give a correct alarm interpretation in order to solve the problem.

The uplink laser is switched on only if downlink optical power is present. In case of any failure, the laser is switched off. By doing this, the unit sends information about its operating status to the TFL.

If the TFA is alarmed, clean the downlink optical connector.

If the TFA is still alarmed, measure the downlink optical power at TFA input with an optical power meter and verify if it is higher than  $-5$  dBm. If it is not, the fibre (at least as far as the down link fibre is concerned) has some problems. If optical power is higher than  $-5$  dBm, replace the TFA.

TPR 19" subrack