



USER INSTALLATION MANUAL

INDEX

1. Installation & safety requirements	3
1.1. Environmental conditions	3
1.2. Installation site features	3
1.3. Connection to the power	3
1.4. Safety and precautions during the installation	3
1.5. Safety and precautions for lasers	3
1.6. Connector care and cleaning	4
2. Warning labels	4
3. Health and safety warnings	5
4. System description	6
4.1. Features	6
4.2. Services	7
4.3. Functional description	7
5. Functional description	9
5.1. Block diagram	9
5.2. Down link operations	9
5.3. Up link operations	9
5.4. Remote supply	10
5.5. Automatic Gain Control	10
6. Alarms and settings	10
6.1. Alarm contacts	11
6.2. UL level setting	11
6.3. Software auto-configuration	11
7. Installation and Cabling	12
7.1. Power supply	12
7.2. RF Ports	13
7.3. Optical fibres connection	13
8. Troubleshooting	14
9. Part description	15
10. Functional description	16
10.1. Block diagram	16
10.2. Up link operations	16
10.3. Down link operations	16
10.4. Remote supply	16
10.5. Automatic Gain Control	16
11. Alarms and settings	17
11.1. Remote unit LEDs	17
11.2. External alarms	17
12. Installing and cabling	18
12.1. Power supply	18
12.2. RF Ports	18
12.3. Optical fibres connection	18
12.4. Test point	19
13. Troubleshooting	19
14. Installation and cabling	20
14.1. Local unit location	20
14.2. Remote unit and antennas location	20
14.3. Power Supply	20
15. System start-up	20
16. Maintenance	20
17. Warranty conditions	21
18. Technical support	22
19. Appendix A : Installation checklist	22
20. Appendix B – Technical specifications	23
21. Appendix C – Mechanical outline	24
22. Appendix D – Power levels	25
23. Appendix E – Using external attenuator	25
24. Appendix f – System Design Guidelines	25
24.1. Introduction	25
24.2. Project Definition	25
24.3. Antennas Positioning	26
25. Appendix G - Classifying hazardous areas	27

GENERAL INFORMATION

1. Installation & safety requirements

1.1. Environmental conditions:

This equipment is designed for indoor use.

Operating temperature: +5 to +40°C

Do not install in corrosive atmosphere or in critical environmental conditions such as hazardous classified areas (see appendix G).

1.2. Installation site features

The local unit should be installed in a dry and suitable location where:

- No explosion risks are present;
- The environment is not classified as high-risk in case of fire;
- Suspended particles are not in great concentration;
- The environment is not subject to any traffic which could cause crash damages;
- The site is properly located with respect to the ergonomic positioning of the working environments;
- The system is placed in a private room, protected against any possible violation;
- The system must not be exposed to ultra-violet rays;
- The site must be accessible by maintenance personnel;
- The site must be dry, with low humidity;
- The site must guarantee proper space for cables and natural ventilation to the system;
- A two meter separation from any heating opening is kept.

The remote units should be mounted in reasonable locations as well:

- Do not install inside heating or conditioning units;
- Do not install inside cable pipeline, fire-prevention site, fire escape, lift tunnels, emergency exits, which have to guarantee defined safety standards;
- Remember that the temperature in the upper part of a room is higher than at 2 meters height. For false ceiling installation, verify that the environment temperatures do not exceed allowed limits;
- The remote unit transmits the RF signal and safety distance for RF radiation must be respected;
- The units must be accessible for tests and maintenance.

1.3. Connection to the power

The connection to the power has to be carried out using the following precautions:

- It must be properly made according to the due diligence rules (IEC rules, etc.);
- In accordance with the rules for the safety against direct or indirect contacts;
- In accordance with the rules for the safety against the over current (short circuit, overloading);
- In accordance with the rules for the safety against over tension;
- The connection is to be carried out by proper and competent staff.

1.4. Safety and precautions during the installation

The following means and tools will be needed for installation:

- Typical electrician tools: cross-point screwdriver, scissors, pliers, nippers, drill and bits, screw for fixing local and remote units to the wall.
- Typical means: Proper ladder, scaffolding or air platform for ceiling installation of remote units.
- Caution should be used when installing at a height upper than 2 meters. Personnel who are installing this equipment should be informed about the possible risks and safety measures when elevated.

1.5. Safety and precautions for lasers

The laser used in BriteCell contains an optical transmitter, which has a power level that is not dangerous to a person's health. However, it is classified as class III A or Class 1 (European norm EN60825) equipment. Nevertheless, it is prudent in the installation phase to observe the following rules:

- ✓ *Never look directly at the internal optic connector of the transmitter apparatus when it is switched on. The wavelength of the laser is not visible to the human eye, which means that long-term damage will not immediately be known.*
- ✓ *When working with the optical connectors, verify at each end that both transmitting lasers are switched off.*





1.6. Connector care and cleaning

Connectors for single mode optical fibre are designed for sub micron tolerances. Such a connector has an optical section of only 9 µm diameter. The optical connector is a high precision device. It must be handled with care, to avoid scratches and other mechanical/optical damages that will impair or reduce the system's performance

The following rules must be carefully followed:

- ✓ Do not leave optical connectors open, as they will attract dirt.
- ✓ Do not touch the connector tip. Clean it with a proper tissue before inserting it into the sleeve.
- ✓ Use pure ethyl alcohol for improved cleaning.
- ✓ Sleeves may be cleaned by injecting pure gas under pressure.
- ✓ Do not attempt to insert connectors mechanically incompatible. This will result in severe damage.

2. Warning labels

	Caution! - Invisible laser radiation from this aperture
	Caution! Laser radiation. Do not stare into the beam or view directly with optical instruments - CLASS 3A laser product
	Caution! - Laser radiation. Do not stare into the beam or view directly with optical instruments - CLASS 1 laser product
	Warning! – 5Vdc on RF connectors. Avoid connecting testing equipment to the RF ports.

3. Health and safety warnings

Antenna installation must conform within the following guidelines to meet FCC RF exposure limits, otherwise an environmental evaluation is required if:

Broadband PCS (subpart E):	
Non-building-mounted antennas:	Height above ground level to lowest point of antenna < 10m Radio (Part 24) and total power of all channels > 2000 W ERP (3280 W EIRP)
Building-mounted antennas:	Total power all channels>2000W ERP (3280W EIRP)
Narrowband PCS (subpart D):	
Non-building-mounted antennas:	Height above ground level to lowest point of antenna < 10m Radio (Part 24) and total power of all channels > 1000 W ERP (1640 W EIRP).
Building-mounted antennas:	Total power of all channels > 1000 W ERP (1640 W EIRP).
Cellular Radiotelephone Service (Part 22, subpart H):	
Non-building-mounted antennas:	Height above ground level to lowest point of antenna < 10m Radio (Part 22) and total power of all channels > 1000 W ERP (1640 W EIRP).
Building-mounted antennas:	Total power of all channels > 1000 W ERP (1640 W EIRP).
Paging and Radiotelephone Service (Part 22, subpart E):	
Non-building-mounted antennas:	Height above ground level to lowest point of antenna < 10m Radio (Part 22) and total power of all channels > 1000 W ERP (1640 W EIRP).
Building-mounted antennas:	Total power of all channels > 1000 W ERP (1640 W EIRP).
Private Land Mobile Radio\ Specialized Mobile Radio (Part 90):	
Non-building-mounted antennas:	Height above ground level to lowest point of antenna < 10m Radio (Part 90) and total power of all channels > 1000 W ERP (1640 W EIRP).
Building-mounted antennas:	Total power of all channels > 1000 W ERP (1640 W EIRP).

IMPORTANT NOTE: To comply with FCC RF exposure compliance requirements, the following antenna installation and device operating configurations must be satisfied: A separation distance of at least 20 cm must be maintained between the antenna of this device and all persons. RF exposure compliance may need to be addressed at the time of licensing, as required by the responsible FCC Bureau(s), including antenna co-location requirements of 1.1307(b)(3). Maximum permissible antenna gain is:

- for the BCR-BCEL FAST719 is 15.4 dBi. (Version TFAF731xx, TFLF734xx)
- for the BCR-BCEL-FAST819 is 11.5 dBi. (Version TFAF23xx, TFLF23xx)

For any clarification, please refer to FCC rules, 47 CFR ch. I, part 1.1307

BRITECELL FAST

4. System description

BRITECELL™ FAST is a plug and play fibre optic distributed antenna kit, offering the most suitable solution for indoor coverage in small areas. The package includes up to four compact RF remote transceivers (TFAF), driven by one local distribution unit (TFLF). It is available in various frequency ranges (from 800MHz up to 2200 MHz) satisfy the requirements of 2nd and 3rd generation mobile networks for simple coverage needs.

The TFLF local unit has been properly designed into a stand-alone mechanical case, including all required ancillary and support functions. The kit includes up to four standard TFAF remote units and a composite fiber-copper cable to connect them to the local unit. The installed remote units can be retained in case of system expansion to a fully modular BriteCell configuration, both single band or dual band, with a minimum setting effort.



Figure 1 Local Unit (TFLF, left) and Remote Unit (TFAF, right)

4.1. Features

Ideal complement to low-power pico BTS or repeater:

- Single band
- Up to 1.5 km optical links
- Wide dynamic range
- Very low power consumption
- Compact and small size
- Easy to install
- Remote alarms
- Plug & play
- Composite cable included

4.2. Services

The BriteCell™ Fast system operates at the following standards:

SERVICE	BANDWIDTH	
	Uplink [MHz]	Downlink [MHz]
TRUNKING RADIO	806:824	851:869
AMPS	824:849	869:894
GSM	890:915	935:960
DCS	1710:1785	1805:1880
PCS	1850:1910	1930:1990
E-GSM	880:915	925:960

4.3. Functional description

The BriteCell™ Fast system is a fibre optic distribution system for wireless signals. It consists of a donor unit (TFLF) feeding up to 4 remote units (TFAF) in a star topology. Each remote unit directly feeds up to two coverage antennas. The connection between the BTS and BriteCell™ FAST system can either be direct or through a repeater via a duplexed N-connector.

Both donor and remote units are powered at –48VDC (telecom supply). Donor and remote units shall be connected with pre-connectorized composite fibre optic cable (cable with twin optical fibre and copper wire for remote supply).

The system installation doesn't require any particular calculation or setting, making it a real plug-and-play system. Some useful functionalities, software and hardware, simplifies diagnostic and commissioning:

- Downlink optical power test point
- Uplink adjustable gain setting
- Link diagnostic by means of individual link LEDs
- Downlink ALC (Automatic Level Control)
- Optical AGC (Automatic Gain Control)

The following picture shows a simplified system block diagram

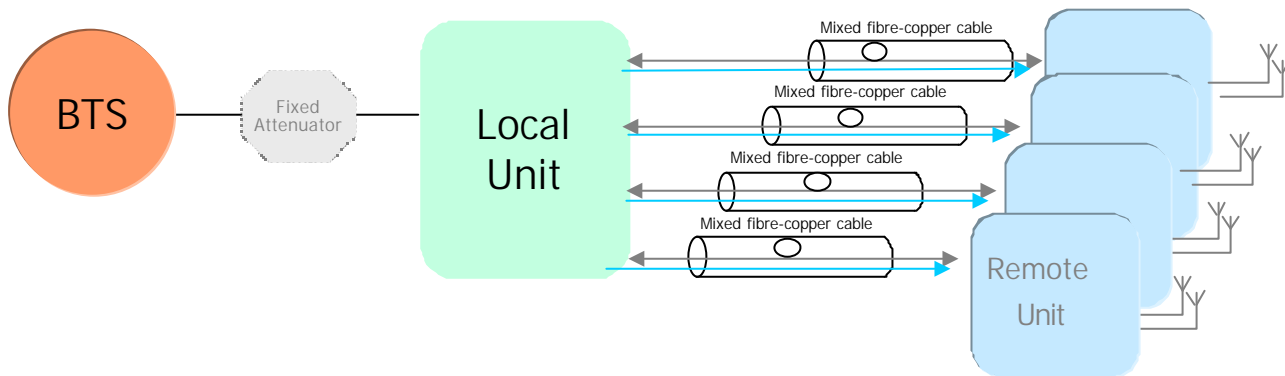

Figure 2 Britecell™ Fast System Block Diagram

TFLF local unit

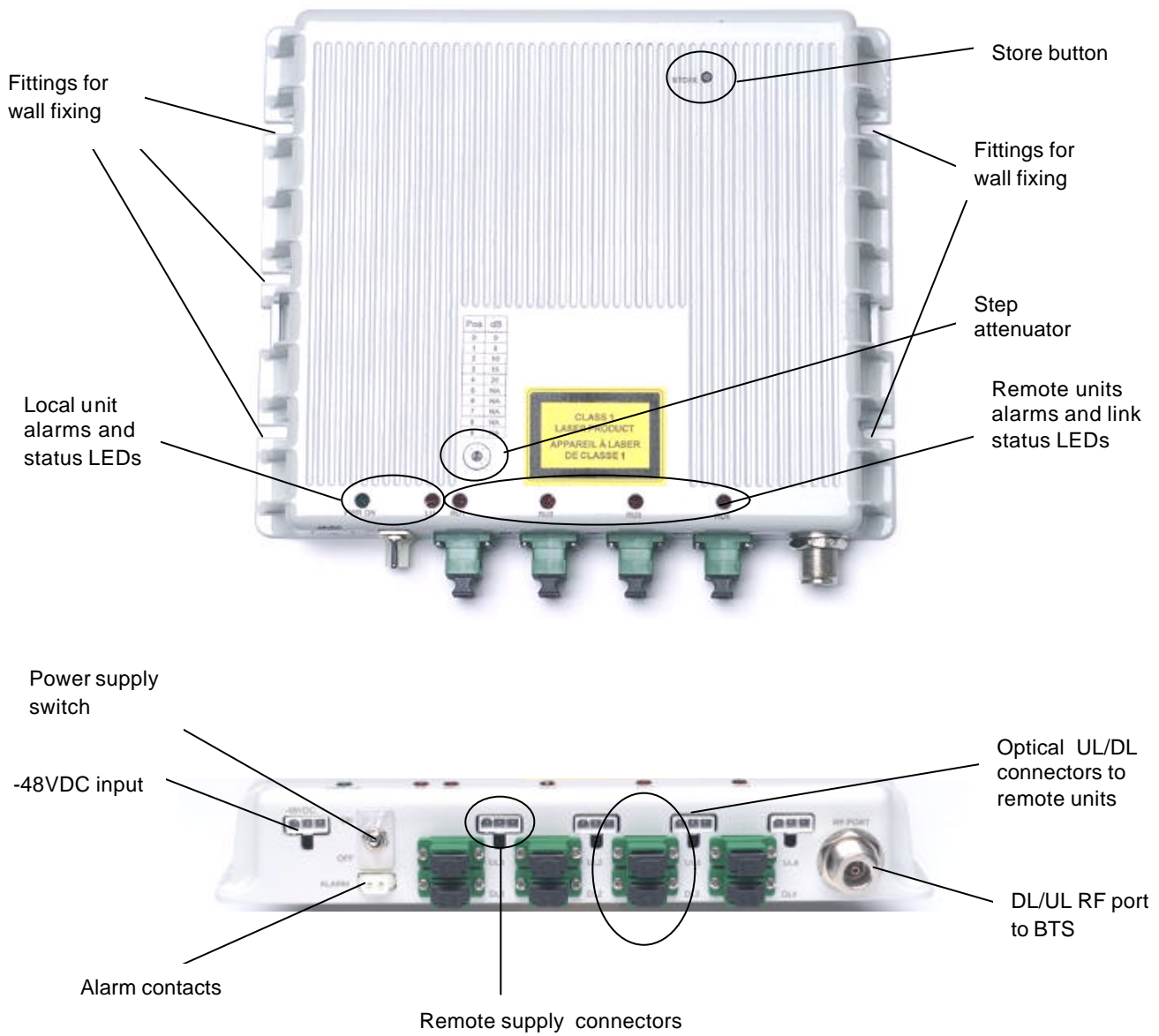

Figure 3 Local Unit (TFLF)

5. Functional description

5.1. Block diagram

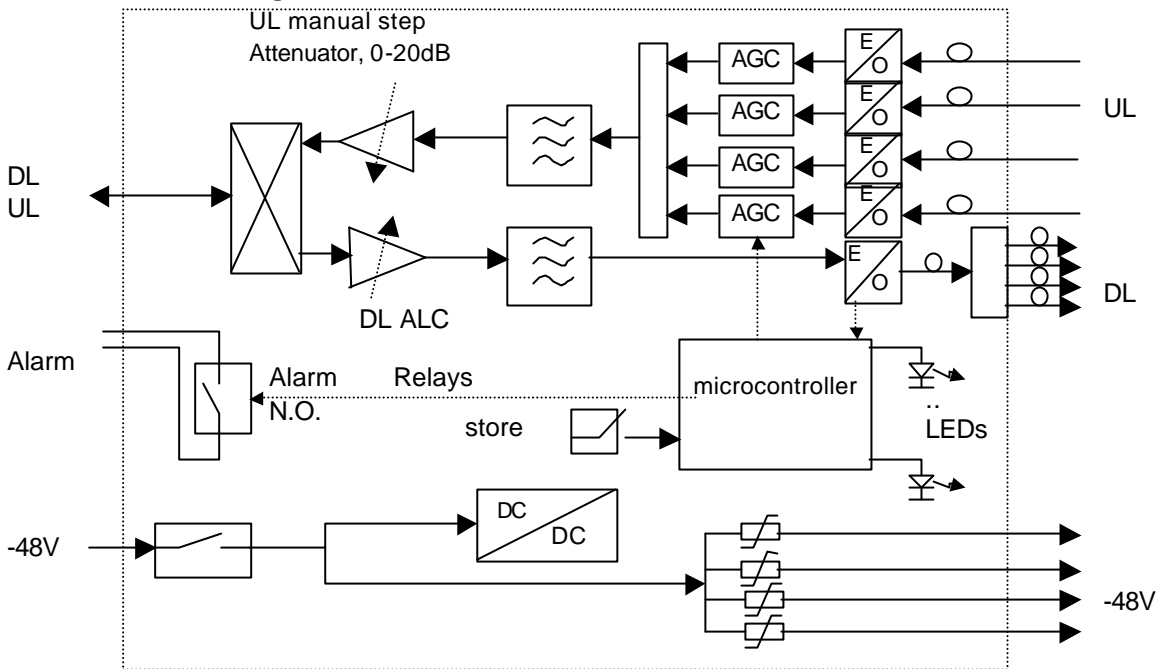

Figure 4 Local Unit (TFLF) Block Diagram

The Local unit is the core of the system and provides the following functionalities:

- RF low power interface and optical conversion.
- Power supply distribution and short/surge protection.
- Alarm interface through dry contact.
- Status and alarm LEDs.
- Automatic Level Control (ALC) in Downlink for overdriving and spurious emission control.
- Automatic Gain Control (AGC) for Uplink optical path loss compensation.
- Microprocessor based supervision and data communication.
- "Store" button for software auto configuration and alarm masking.
- Step attenuator for uplink gain setting.

5.2. Down link operations

In the downlink path the TFLF fulfils the following operations:

Power level adjustment: The TFLF local unit is designed to be interfaced with a wide range of low power BTS and repeaters. For higher power BTS's an external fixed attenuator is required. Refer to the Appendix for the typical and maximum allowed input levels. Because the RF port is duplexed, an external attenuator will add the same downlink loss to the uplink path. To compensate for this loss, the TFLF uplink gain must be adjusted by means of the UL step attenuator.

The DL RF power is limited from the ALC to avoid spurious emissions in case of overdriving inputs.

E/O Conversion: The RF signal modulates the intensity of an optical carrier through an electro-optic device (laser).

Optical Splitting: The modulated optical carrier is split into 4 ways so that it may be transmitted on a maximum of 4 optical links.

5.3. Up link operations

O/E Conversion: There are 4 O/E conversion devices, or optical receivers, in the TFLF, one for each optical link. The modulated optical signal coming from the remote units is detected and

demodulated back to an electrical signal. The data link associated with each remote unit is also detected and routed to the microprocessor.

Amplification & AGC: Variable amplification is needed to compensate for the variable optical fibre loss, maintaining a good signal to noise ratio, so that for each link a constant gain is obtained.

RF Combining: Signals coming from all remotes are combined into a single RF path, filtered and duplexed into the RF port.

5.4. Remote supply

The local unit provides connection and distribution for -48VDC supply to the remote units, by means of composite cable, copper wires and optical fibre pairs. Each supply port is protected against overloads, short and surge with a self-recovery fuse and surge protection. The power switch will disconnect the remote supply in case of overcurrent.

5.5. Automatic Gain Control

Optical link losses are typically related to:

- Fibre length (0.2-0.4dB/Km @ 1300nm)
- Splices loss
- Optical connectors tolerances and aging

BriteCell™ Fast implements an automatic gain control (AGC) mechanism to maintain constant RF link gain, regardless of the overall optical link losses. The allowed optical loss per link must be in the range of 3dB. Losses outside this window will trigger alarms and warnings according to the following table:

OPTICAL LOSS	OPERATION	ALARM	SEVERITY
0 dB	AGC working, constant RF gain	none	NONE
< 3dB	AGC working, constant RF gain	none	NONE
< 5 dB	AGC not working, RF gain decreases according to 2dB electrical per 1dB optical	AGC out of range: red LED flashes	MINOR
> 5 dB	AGC not working, the optical signal is too low, the receiver is automatically switched off in order to reduce the unwanted noise to the system.	Optical power too low: red LED fixed, relays alarmed.	MAJOR

6. Alarms and settings

Local unit LEDs are fully managed by software according to different severity levels, and reported as relay contact and visual alarms (LEDs). There are six LED's on the Local unit. Four are related to each optical link and remote unit, one is related to local unit, and one is for power supply.



Figure 5 TFLF Local Unit Status LED's

The local unit has different monitor signals, leading to different alarms:

ALARM DESCRIPTION	LED	STATUS	SEVERITY	COLOR
UL AGC out of range	RU1, 2, 3, or 4	Flashing	MINOR	Red
UL optical power too low	RU1, 2, 3, or 4	Fixed	MAJOR	Red
DL laser optical power too low	LU	Fixed	MAJOR	Red
UL RF amplifier	LU	Fixed	MAJOR	Red
DL RF amplifier	LU	Fixed	MAJOR	Red
Temperature alarm	LU	Flashing	MINOR	Red
Supply alarm	LU	Fixed	MAJOR	Green

The Link LEDs (RU1, 2, 3, and 4) report information from the remote units, according to the following table:

ALARM DESCRIPTION	LED	STATUS	SEVERITY
DL AGC out of range	RU1, 2, 3, or 4	Flashing	MINOR
DL optical power too low	RU1, 2, 3, or 4	Fixed	MAJOR
DL RF amplifier 1	RU1, 2, 3, or 4	Fixed	MAJOR
DL RF amplifier 2	RU1, 2, 3, or 4	Fixed	MAJOR
Antenna disconnected (DC loop)	RU1, 2, 3, or 4	Flashing	MINOR
External 1	RU1, 2, 3, or 4	Fixed	MAJOR
External 2	RU1, 2, 3, or 4	Fixed	MAJOR

6.1. Alarm contacts

The TFLF provides dry contacts to report alarm condition to third party equipment auxiliary inputs (i.e. BTS or repeater). The dry contacts status is reported in the following table:

ALARM CONDITION	CONTACT POSITION
NONE	OPEN
MINOR	OPEN
MAJOR	CLOSED

If the alarm condition is “none” (contact open) the relays driving the contacts are normally excited. In case of power supply failure the system is not powered and the dry contacts will be automatically driven to a “closed condition”, corresponding to a “major” alarm.

6.2. UL level setting

The TFLF is designed to be compatible with most pico/micro BTS's. The allowed levels can span from 10mW to 5W. Power levels greater than 100mW require an external attenuator. This external attenuator will affect both the uplink and downlink paths, adding unwanted attenuation to the uplink path.

In this case, the variable uplink attenuator must be adjusted (the range is 20dB with 5dB steps), as per table in the appendix E.

To adjust the value use a flat screwdriver

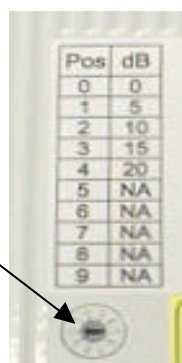

Figure 6 Uplink Attenuator Adjustment

6.3. Software auto-configuration

A simple procedure is required to set the final system configuration. This is necessary in case of a partially populated system, where optical alarms can arise if some optical ports are not connected to remote units. The procedure to be followed is reported below:

STEP	SET CONFIGURATION ACTION
1	Install your system properly, according to the required number of remote units, and power up the system.
2	Wait until the communication between TFLF and TFAF's are established and the alarms relevant to UNUSED port arises (LU LED fixed).
3	Verify that all USED ports don't have active alarms. In case, please follow the troubleshooting steps to remove unwanted alarms.
4	Press the "store button" for at least 5 second.
5	All the TFLF LEDs will flash for 3 seconds, and the UNUSED port alarms will disappear. All the alarms relevant to unused ports will be disabled.
6	Switch off the system, wait a few seconds, power up and verify the unwanted alarms are masked.

A restore procedure is available to replace a wrong configuration and restore the initial configuration:

STEP	RESTORE CONFIGURATION ACTION
1	Power off the system while holding down the "store" button.
2	Power on the system.
3	The LED will flash for 2 seconds.
4	All of the active alarms will be displayed again.

7. Installation and Cabling

7.1. Power supply

The system is designed to be powered by standard telecom voltage -48VDC . The power consumption is 9W for the TFLF. The supply connector part name is MOLEX 5569-03. A connectorized jumper is shipped with each Local unit.

- ✓ *WARNING: The system is connected POSITIVE to GROUND. Grounding connections must be carefully managed in order to avoid reverse polarity mistakes*



Figure 7 DC Power Connections for Local Unit TFLF

7.2. RF Ports

The RF port is a duplexed N-female connector. See the tables in the Appendix to set the proper input level.

- ✓ **WARNING:** Do not exceed the maximum RF level allowed for downlink input. See appendix B - technical specifications

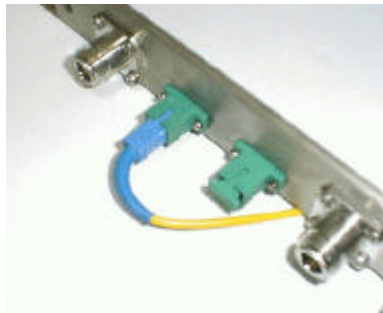

Figure 8 RF Connector for Local Unit TLFL

7.3. Optical fibres connection

Optical connectors need to have proper alignment and mechanical support. When inserting an optical connector, take care to handle it carefully to avoid damage to the fibre. Remove the dust cap only prior to making connections.

- ✓ Do not force or stretch the fibre pigtail with curve radius less than 5 cm.
- ✓ See Figure 9 for optimal fibre cabling.



WRONG

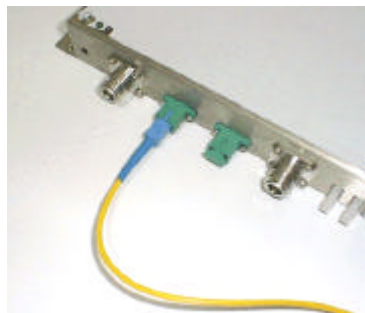

OPTIMAL

Figure 9 Optical Fiber Connection Examples

8. Troubleshooting

ALARM DESCRIPTION	LED	STATUS	SEVERITY	ACTION
UL AGC out of range	RU1, 2, 3, or 4	Flashing	MINOR	Optical power below -4dBm: check for fiber or splices stresses, clean optical connectors
UL optical power too low	RU1, 2, 3, or 4	Fixed	MAJOR	Low optical power below -6 dBm: check for fiber or splices stresses, clean optical connectors If TFAF has faulty laser, replace TFAF
DL laser optical power too low	LU	Fixed	MAJOR	Laser failure: replace TFLF
UL RF amplifier	LU	Fixed	MAJOR	Internal failure: replace TFLF
DL RF amplifier	LU	Fixed	MAJOR	Internal failure: replace TFLF
Temperature alarm	LU	Flashing	MINOR	External temperature too high: check air circulation
Supply alarm	LU	Fixed	MAJOR	Internal failure: replace TFLF
REMOTE UNIT ALARM DESCRIPTION				
DL AGC out of range	RU1, 2, 3, or 4	Flashing	MINOR	Optical power below -4dBm: check for fiber or splices stresses, clean optical connectors
DL optical power too low	RU1, 2, 3, or 4	Fixed	MAJOR	Optical power below -6dBm: check for fiber or splices stresses, clean optical connectors
DL RF amplifier 1	RU1, 2, 3, or 4	Fixed	MAJOR	Internal failure: replace TFAF
DL RF amplifier 2	RU1, 2, 3, or 4	Fixed	MAJOR	Internal failure: replace TFAF
Antenna disconnected (DC loop)	RU1, 2, 3, or 4	Flashing	MINOR	Antenna cable probably broken or disconnected. Antenna connected to TFAF doesn't support DC-loop→ see store procedure to mask unwanted alarm
External 1	RU1, 2, 3, or 4	Fixed	MAJOR	External alarm 1
External 2	RU1, 2, 3, or 4	Fixed	MAJOR	External alarm 2

NOTE: All major alarms will trigger the dry contacts to "closed" status.

TFAF remote unit

9. Part description

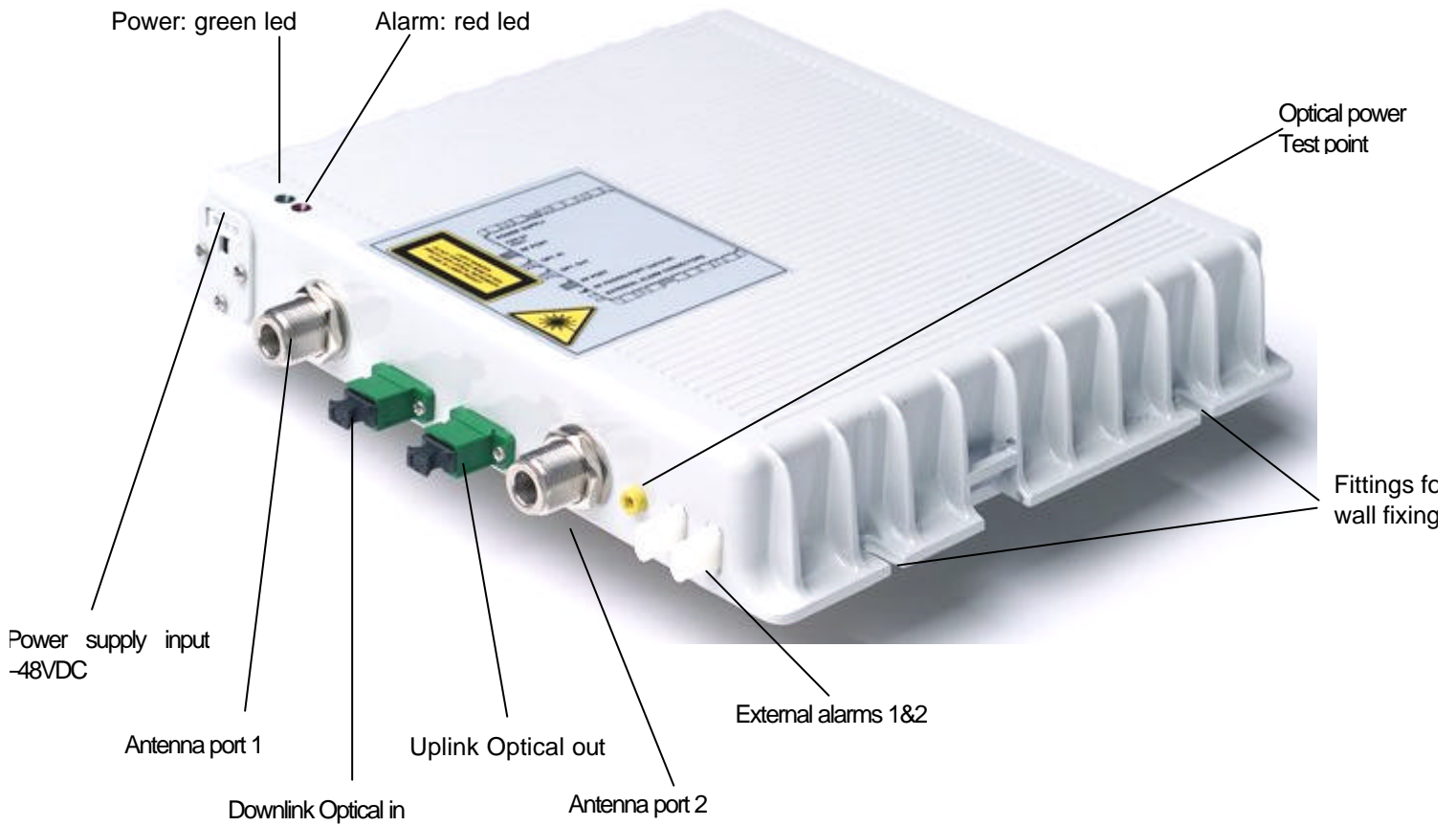

Figure 10 Remote Unit TFAF

10. Functional description

10.1. Block diagram

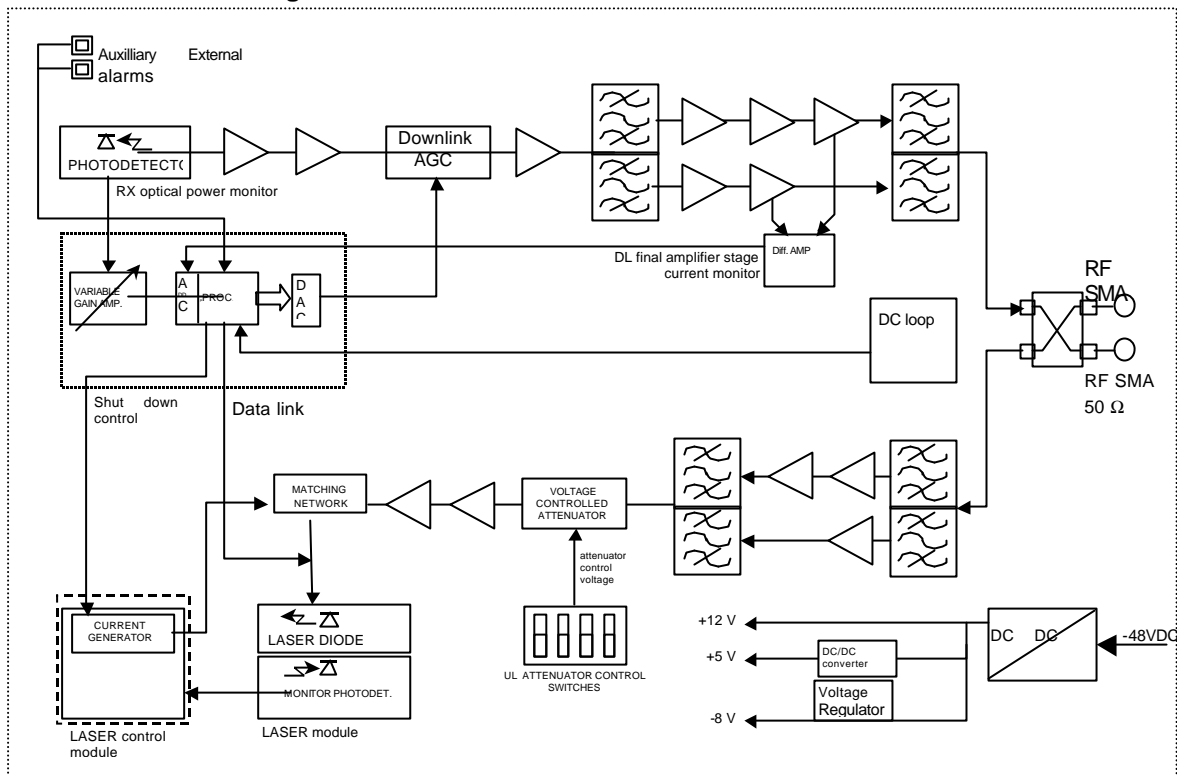

Figure 11 Remote Unit TFAF Block Diagram

10.2. Up link operations

Low noise amplification: the low level signal coming from the antenna and duplexer is amplified and filtered.

E/O Conversion: The RF signal modulates the intensity of an optical carrier through an electro-optic device (laser).

10.3. Down link operations

O/E Conversion: The modulated optical signal coming from the local units is detected and demodulated back to electrical signal.

Amplification & AGC: Variable amplification is needed to compensate for the variable optical fibre loss, maintaining a good signal to noise ratio, to maintain a constant gain for each link. The resultant signal is amplified, filtered and is duplexed to feed the antenna.

10.4. Remote supply

The remote unit is powered with -48VDC supply, positive to GROUND, by means of composite copper wire and fibre cable.

10.5. Automatic Gain Control

Optical link losses are typically related to:

- Fibre length (0.2-0.4dB/Km @ 1300nm)
- Splices loss
- Optical connectors tolerances and aging

BriteCell™ Fast implements an automatic gain control (AGC) mechanism to maintain constant RF link gain, regardless of the overall optical link losses. The allowed optical loss per link must be in the range of 3dB. Losses outside this window will trigger alarms and warnings according to the following table:

OPTICAL LOSS	OPERATION	ALARM	SEVERITY
0 dB	AGC working, constant RF gain	none	NONE
< 3dB	AGC working, constant RF gain	none	NONE
< 5 dB	AGC not working, RF gain decreases according to 2dB electrical per 1dB optical	AGC out of range: red LED flashes	MINOR
> 5 dB	AGC not working, the optical signal is too low, the receiver is automatically switched off in order to reduce the unwanted noise to the system.	Optical power too low: red LED fixed, relays alarmed.	MAJOR

11. Alarms and settings

11.1. Remote unit LEDs

The TFAF is fully managed and supervised by the local microprocessor. The alarms are fully managed by software according to different severity levels, and reported as local visual alarms (LED's) and on the data link to the local unit.

There are 2 LED on the Local unit, one red alarm LED is related to optical link and internal failures, one green LED is for the power supply.



Figure 12 Remote Unit TFAF LED's

REMOTE ALARM DESCRIPTION	LED	STATUS	SEVERITY
UL AGC out of range	RED	Flashing	MINOR
UL optical power too low	RED	Fixed	MAJOR
DL RF amplifier 1	RED	Fixed	MAJOR
DL RF amplifier 2	RED	Fixed	MAJOR
Antenna disconnected (DC loop)	RED	Flashing	MINOR
External 1	RED	Fixed	MAJOR
External 2	RED	Fixed	MAJOR

11.2. External alarms

Two external alarm contacts are provided. These contacts are open under non-alarm condition.



Figure 13 Remote Unit TFAF Alarm Connectors

12. Installing and cabling

12.1. Power supply

The system is designed to be powered by standard telecom voltage –48VDC. The power consumption is 12W for the TFAF. The supply connector part name is MOLEX 5569-03. A connectorized jumper is shipped with each remote unit.

- ✓ *WARNING: The system is connected POSITIVE to GROUND. Grounding connections must be carefully managed in order to avoid reverse polarity mistakes*



Figure 14 DC Power Connections for Remote Unit TFAF

12.2. RF Ports

The RF port is a duplexed Nfemale connector. A DC loop mechanism is implemented to detect a broken cable or a disconnected antenna. To perform this functionality a DC loop antenna must be used. If the DC loop functionality cannot be used, follow the “store” procedure in the TFLF to mask the DC loop alarm.

- ✓ *WARNING: If passive distribution is used after the remote unit, verify that passive splitters can be DC loop enabled.*
- ✓ *WARNING: Both RF ports are supplied with a DC current of 2mA(max) @5Volts.*



Figure 15 Remote Unit TFAF RF Connectors

12.3. Optical fibres connection

Optical connectors need to have proper alignment and mechanical support. When inserting an optical connector, take care to handle it carefully to avoid damage to the fibre. Remove the dust cap only prior to making connections.

- ✓ *Do not force or stretch the fibre pigtail with curve radius less than 5 cm.*
- ✓ *See Figure 16 for optimal fibre cabling.*

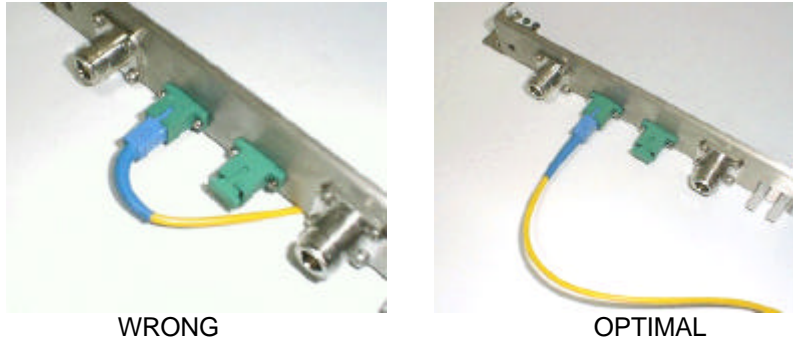

Figure 16 Optical Fiber Connection Examples

12.4. Test point

An electrical test point is available on the remote unit to check the downlink optical power. Connect the fibre coming from the local unit, power both units and measure with a multimeter the voltage between ground and the test point. A satisfactory DL optical power will give measurement greater than 300mV, corresponding to an optical power level of around -5dBm.

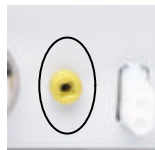

Figure 17 Remote Unit TFAF Electrical Test Point

13. Troubleshooting

REMOTE UNIT ALARM	Alarm LED	STATUS	SEVERITY	ACTION
DL AGC out of range	RED	Flashing	MINOR	Optical power below -4dBm: check for fiber or splices stresses, clean optical connectors
DL optical power too low	RED	Fixed	MAJOR	Optical power below -6dBm: check for fiber or splices stresses, clean optical connectors
DL RF amplifier 1	RED	Fixed	MAJOR	Internal failure: replace TFAF
DL RF amplifier 2	RED	Fixed	MAJOR	Internal failure: replace TFAF
Antenna disconnected (DC loop)	RED	Flashing	MINOR	Antenna cable probably broken or disconnected. Antenna connected to TFAF doesn't support DC-loop → see store procedure to mask unwanted alarm
External 1	RED	Fixed	MAJOR	External alarm 1
External 2	RED	Fixed	MAJOR	External alarm 2

SYSTEM INSTALLATION

14. Installation and cabling

BriteCell™ FAST is designed to be simple and easy to install and commission. It requires a minimum number of tools and equipment. However, it is necessary to observe local regulations when planning and implementing an RF system and safety conventions must be strictly adhered to at all times. Particular attention should be paid to the presence of optical lasers, which can represent the only potential hazard related to the use of BriteCell equipment. A working knowledge of optics, and the safety procedures in their use, is required by the installation, commissioning and maintenance staff.

14.1. Local unit location

TFLF local units should be placed as near as possible to the BTS or the RF repeater and should be easily accessible as they provide visual alarm information for the system maintenance.

- ✓ *The position of the remote unit should be vertical to maximize thermal dissipation.*
- ✓ *There should be easy access to the optical and RF cables.*

14.2. Remote unit and antennas location

The most efficient locations for the TFAF remote transceivers will minimise the number of antennas required, while maintaining the coverage level goal.

- ✓ *The position of the remote unit should be vertical to maximize thermal dissipation.*
- ✓ *There should be easy access to the optical and RF cables.*

The passive antenna's placing should be chosen provide the maximum indoor radio coverage, and should be mounted at a minimum height of 2.5m from the ground. They should not be placed near trees, plants, metal grids or other obstacles, which could disturb their functionality and lead to a degradation of the device's performance.

14.3. Power Supply

A BriteCell™ Fast system has been designed for remote power distribution, but is also possible to supply each unit separately at –48VDC. A power supply may be distributed in a composite cable, copper and fibre, or two separate parallel cables may be run. A suitable external adapter to provide at least 100W at –48VDC must be used.

15. System start-up

To avoid damaging the equipment, the following criteria must be used to start up the system:

1. Verify all the power supply connections.
2. Verify all the RF connections and power levels at the BTS/Repeater interface.
3. Verify all the optical connections.
4. Switch on the system.
5. Check for alarm status and in case of alarm refer to troubleshooting paragraph.

16. Maintenance

It is a good rule, when working with the fibre optic components, to always dispose of the appropriate screw covers for closure of the optic connectors that are not connected. The intrinsic delicateness of an optic connection must be highlighted. A minimum layer of dust causes a notable increase of the insertion loss, therefore:

- ✓ *Always close the optic connectors that are not connected with the appropriate screw covers.*
- ✓ *Always use compressed gas to remove any deposits in the receptacles before closing them.*
- ✓ *Use the appropriate cloths to clean the connectors.*
- ✓ *Do not allow the male connector to come into contact with skin or oily surfaces.*
- ✓ *Should it be necessary to clean the optic connector, only use pure alcohol.*

OTHER INFORMATION

17. Warranty conditions

Customer service is granted all over the world during and after the warranty period.

Allen Telecom warrants to the terms and conditions hereto set forth, all products manufactured by it to be free under normal use and service from defects in materials and workmanship for a period of one (1) year from the date of shipment to the first consumer (the "Warranty Period"). The warranty applies only if the warranty period is not expired and the defect is imputable to the product.

Our obligation under this Warranty is limited to prompt repair or replacement of the product, without charge, when the product is returned to the factory.

The warranty shall not apply to any product which has been repaired or altered in any manner or if the defect, malfunction or failure of the product was caused by damage by lightning, flood or other acts of nature or by power surges, or from unreasonable use, or from improper installation or application, or to any product which has not been maintained or used in accordance with the operating specifications set forth in this manual.

Allen Telecom evaluates if the product can be repaired or if it is necessary to replace the unit. In case the product is out of warranty, the customer will be informed about the cost for repairing or replacing the unit. The service will be provided only after receiving Customer's authorisation.

Before returning the goods, the customer should give prior notice to Allen Telecom through normal return authorisation procedure. Allen Telecom aims to offer an excellent service. To do that we ask our customer to enclose with the returned product an accompanying letter, including the following information:

Company name	
Address	
Contact person	
Invoice number	
Delivery note	
No. of pieces	
Model*	
Serial Number*	
Lot*	
Year*	
Description of the Failure/defect	

* Refer to the serial label

Note: Each product must be packaged with care before shipment.

Allen Telecom will issue a check report, which is included in the packing together with the product being returned. The customer will be informed about any corrective actions suggested by quality assurance.

18. Technical support

Our on-line help desk at www.tekmar.it gives immediate access to our team of Experts, who are committed to providing you with the best service in the shortest possible time.

For further information on the product, not described in this publication, you can contact our Project Implementation & technical support team at helpdesk@tekmar.it

APPENDIX

19. Appendix A : Installation checklist

The following checklist provides a summary of the procedures for installing a BriteCell™ Fast system.

Step	Item/ Action	Description	--
1	BriteCell™ Fast Site Drawing	<i>Master copy of the site plan noting the remote locations and serial numbers, and the location of the indoor coverage antenna(s). This should characterize the design parameters for the system including cable paths and lengths.</i>	
2	Equipment List:	<i>Quantity & serial numbers:</i>	
	BriteCell™ Fast Donor		
	BriteCell™ Fast Remotes		
	AC Power Source		
	AC Power Outlet		
	Coverage Antenna(s)		
	Input coaxial cable		
	Coverage Antenna Cables		
3	Installation tools:		
	Cable connector Tools*	<i>Crimper, knife, etc.</i>	
	Multimeter	<i>To ensure no cable shorts.</i>	
	Handset with Power Indicator	<i>To verify coverage after commissioning.</i>	
4	Run Cable	<i>Install Cable in the site.</i>	
5	Attach Connectors*	<i>Measure resistance across center pin and outer shell (ground) to ensure no short.</i>	
7	Record Serial Numbers and Locations on site Drawing.	<i>Note: this is to help Technical Support Specialists, should you need their assistance.</i>	
8	Mount the Equipment	<i>Including indoor coverage antennas.</i>	
9	Connect the coaxial cables as shown on the Site Plan	<i>Use caution when connecting semi-flexible cables to the mounted BriteCell™ Fast and antennas. Excessive force on antenna or BriteCell™ Fast connectors will result in serious equipment damage.</i>	
10	Supply AC Power, and commission the System.	<i>Check the BriteCell™ Fast status LED's.</i>	
11	Check Power Levels	<i>Check power indication of handheld mobile at various locations within the coverage area.</i>	

* As Required

20. Appendix B – Technical specifications

TFAF - REMOTE UNIT

Downlink	
Optical receiver	PIN photodiode
Max allowed input optical power	< +3dBm
Allowed input optical power under AGC	0dBm ...-3dBm
Allowed optical input back reflection	> -36dB
Optical input alarm threshold	<-5dBm
Uplink	
Optical transmitter	Laser diode, class 3A (EN60825)
Wavelength	1310 ± 10nm
Output optical power	-1dBm typ.
Max allowed RF input level	-15dBm (1 tone CW)
RF interface	
Operating frequency band	See options & configurations table
RF ports	2
Connector	N-f
Impedance	50 Ω
Return loss	> 10 dB
Mechanical & environmental	
Dimensions (mm)	240h x 200w x 36d
Weight	1.7 Kg max
Colour	RAL 7035
Power supply (negative supply)	-48VDC, 15W max
Alarms	Major and minor led alarm (see manual)
Temperature range Operating: Storage:	5 ÷ +40 °C -20 ÷ +65 °C
MTBF	>200.000 h @25°C
Compliance	UL-94; ETS300 019-1-3, class 3.1; EN55022 class B - EN60950, CE

TFLF - LOCAL UNIT

Downlink (1 section of 4)	
Optical transmitter	Laser diode, class 1 (EN60825)
Wavelength	1310 ± 10nm
Output optical power	+0dBm typical
Max allowed RF input level	+27dBm (1 tone CW)
Uplink(1 section of 4)	
Optical receiver	PIN photodiode
Max. allowed input optical power	< +3dBm
Allowed input optical power under AGC	-1dBm ÷ -4dBm
Allowed optical input back reflection	< -36dB
RF presettable gain reduction (PGR2)	0/5/10/15/20 dB
Optical input alarm threshold	<-6dBm
RF interface	
Operating frequency band	See options & configurations table
Connector	N-f
Impedance	50Ω
Return loss	> 12dB
Mechanical & environmental	
Dimensions (mm)	240h x 200w x 36d
Weight	1.7 Kg max
Colour	RAL 7035
Power supply (negative supply)	-48VDC, 10W max power consumption with 4 TFAF (remote supply) < 80W
Temperature range Operating: Storage:	5 ÷ +40 °C -20 ÷ +65 °C
Alarms	Local led alarm (major or minor) Remote and optical link led alarm (major or minor) (see manual) Dry-contact major alarm
Compliance	UL-94; ETS300 019-1-3, class 3.1; EN 60950

RF SYSTEM PERFORMANCE TFLF+1 of 4 TFAF (1 of 2 TFAF RF ports)

Downlink	GSM (900MHz)	AMPS/Trunking (800MHz)	DCS (1800MHz)	PCS (1900MHz)
Frequency translation	None			
Nominal RF input level	+13dBm (1 tone CW)			
Max allowed RF input level	+27dBm (1 tone CW)			
Nominal RF gain	0dB			
Flatness (in passband)	±2dB			
Output wideband noise	<-120dBm/Hz			
Max RF output level under ALC (note1)	+13 dBm typ.	+18 dBm typ.	+13dBm typ.	+17dBm typ.
Output 1dB compression point	>+22dBm		>+20dBm	
Output spurious and intermodulations	<-36dBm	<-13dBm	<-30dBm	<-13dBm
RF output power per carrier	see attached table			
Output third order intercept point OIP3	>+33dBm	>+33dBm	>+30dBm	>+30dBm
Uplink				
Frequency translation	None			
Nominal RF gain (note 2)	+12 dB			
Flatness (in passband)	± 2 dB			
RF presettable gain reduction (PRG note3)	PRG2: 0/5/10/15/20 dB			
Noise figure	13 dB typ.			
Input third order intercept point IIP3	0dBm typ.			
Blocking at 3 dB C/N degradation	>-18dBm			
Spurious free dynamic range (BW=25KHz)	78dB typ.			
Spurious free dynamic range (BW=30KHz)	77dB typ.			
Spurious free dynamic range (BW=200KHz)	72dB typ.			
Spurious free dynamic range (BW=1230KHz)	67dB typ.			
Fibre optic link				
Fibre optic type	Single mode, 9.5/125um			
Max allowed optical fibre length	< 1.5km			
Max allowed optical budget for AGC operation	3 dB (optical)			
Max. propagation delay including 1km single mode fibre	<5,2µs			

Note 1: Measured with 1 CW tone

Note 2: with PRG1 and PRG2 set to 0

Note 3: PRG2 is on TFLF unit and it could be used for different BTS: (see manual)

21. Appendix C – Mechanical outline

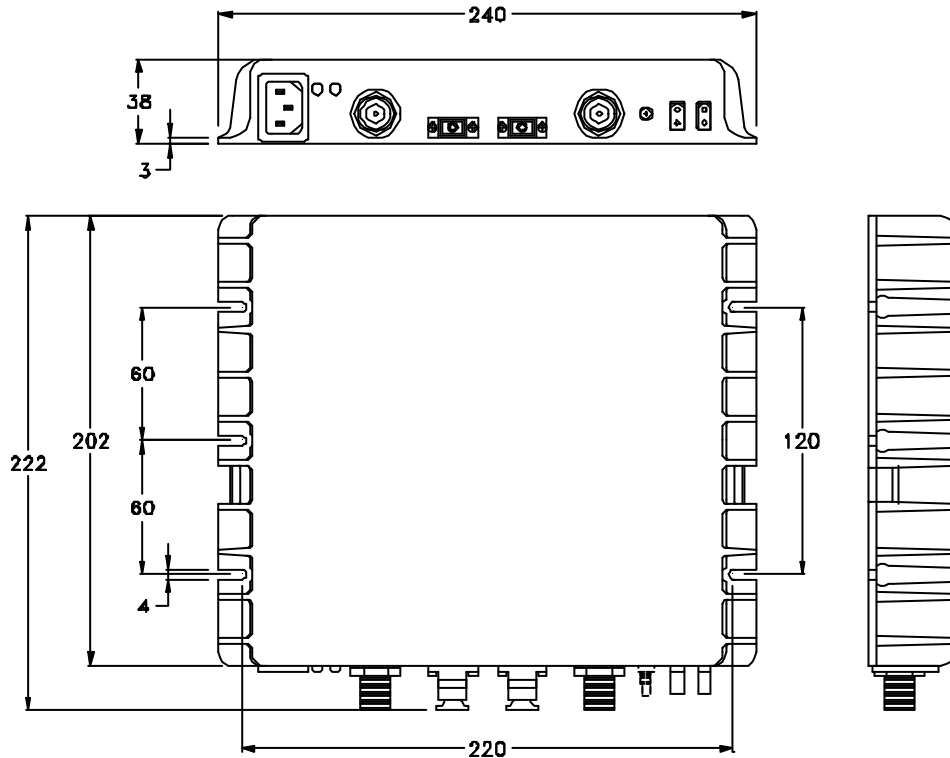

22. Appendix D – Power levels

Typical Output levels (dBm) at each TFA RF port versus different modulation scheme.

(NB: system gain is 0db, therefore the following values correspond also to min input levels)

Carriers	CW	GSM 900	GSM 1800	CDMA 800	CDMA 1800	Analog	IDEN	TDMA 800	TDMA 1900
1	+13.0	+19.0	+19.0	+15.5	+14.5	+19.0	+11.0	+19.0	+18.0
2	+10.0	+10.0	+10.0	+10.0	+10.0	+14.0	+8.0	+14.0	+13.0
3	+7.7	+7.7	+7.7	+5.0	+5.0	+12.0	+6.0	+12.0	+11.0
4	+6.7	+6.7	+6.7	+3.5	+3.5	+11.0	+4.5	+11.0	+10.0

23. Appendix E – Using external attenuator

The uplink step attenuator must be set to optimise the system performance dependent upon the power into the BriteCell Fast TFLF local unit. The following table gives some examples:

Input Power	External Attenuation	TFLF Attenuation setting	Uplink Gain (TFAF+TFLF)	Downlink Gain
+37dBm	20 dB (5W)	0 dB	+12 dB	-20 dB
+33dBm	20 dB (2W)	0 dB	+12 dB	-20 dB
+24dBm	10 dB	10 dB	+2 dB	-10 dB
+20dBm	5 dB	5 dB	-3 dB	-5 dB
+14dBm	0 dB	20 dB	-8 dB	0 dB
+13dBm	0 dB	20 dB	-8 dB	0 dB

24. Appendix F – System Design Guidelines

24.1. Introduction

This Appendix is intended to describe the guidelines for the design development of the BriteCell/BriteCell Fast System.

24.2. Project Definition

In order to allow the design development, it's important to collect the right information. The input parameters needed for the BriteCell coverage design are:

1. **The type of standard:** (GSM, CDMA, DCS, ...);
2. **The frequency:** needed in order to choose the proper equipment and to evaluate the path loss;
3. **The number of carriers:** important to define the input/output level of the equipment;
4. **The BTS type:** the link between BTSs and BriteCell coverage system can be Direct Connection or Radio Connection, so it's important to know which of these configuration is used. The type of BTS is needed in order to properly set up the UL and DL variable attenuators;
5. **Definition of the coverage area based on the map:** to define the number of radiating points and their location, it's important to consider:
 - The kind of walls and floors
 - The presence of false ceiling
 - Eventual obstacles (architectural or furnishing)
 - The required minimum receive level for mobile
 - The power supply

24.3. Antennas Positioning

Starting with the parameters determined as defined above, the number of radiating points can be defined. The calculations needed can be implemented in a tool. The number of carriers is used to define the TFA/TFAF RF Output Power ($P_{OUT\ TFA}$ in Figure 18) according to the table in Appendix C. As a rule of thumb, the power values for a double number of carriers is obtained reducing the Power value of 3dB.

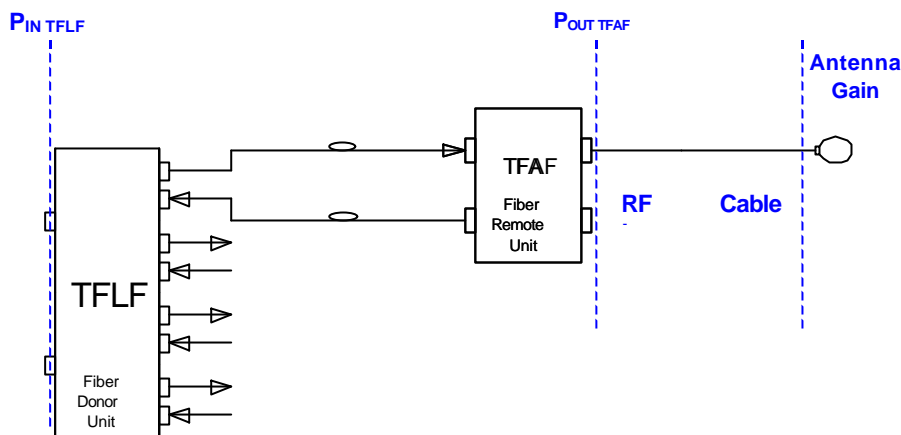

Figure 18 Diagram for Power Calculations

According to line-of-sight conditions, the calculation of the maximum coverage distance is performed using the Free-space propagation formula. This formula is adapted to propagation in indoor environments introducing an appropriate propagation index and including margin against fading.

24.3.1. EIRP calculation:

$$EIRP_{[dBm]} = P_{OUT\ TFAF[dBm]} + G_{Directivity[dBi]} - A_{Splitter[dB]} - A_{RF_Cable[dB]}$$

where;

- $P_{OUT\ TFAF}$ = Remote Unit RF connector Output Power;
- $G_{Directivity}$ = Directivity Gain of the Antenna;
- $A_{Splitter}$ = Splitter Insertion loss;
- A_{RF_Cable} = RF Cable Loss.

24.3.2. Max Coverage Distance Calculation:

$$Max_Distance_{to_Prx_min[m]} = \frac{\lambda_{[m]}}{4\pi} \cdot \left(10^{\frac{EIRP_{[dBm]} - MF_{[dB]} - A_{Walls[dB]} - P_{Rx_min[dBm]}}{10}} \right)^{\frac{1}{Exp_{PL}}} \text{ where}$$

e;

- MF = Margin against Fading;
- A_{Walls} = Walls supplementary Attenuation;
- P_{Rx_min} = Minimum Required Power Level;
- Exp_{PL} = Path Loss Exponent (propagation index);
- λ = Wavelength.

The results can be detailed for different Remote Unit configuration (splitter insertion loss, RF cable length, additional attenuation e.g. walls).

- ✓ Depending on the number of RF carriers, the antenna type and the RF cables type, the maximum distance that the system is able to perform is estimated. This calculation is used to plan antenna positioning so that the project requirement (Minimum Down Link Power Level) is met.
- ✓ **Technical Suggestion:** The design is an iteration process so it's advisable to start from the hypothesis that the Cable Loss and the Antenna Gain compensate each other and consequently the EIRP is equal to the TFA Output Power. To reach a good coverage, a target is to choose the antenna positioning in order to maximize Line of Sight.

25. Appendix G - Classifying hazardous areas

Hazardous Area

A hazardous area is defined as: "An area in which a flammable substance in the form of gas or vapour or dust, when mixed with air, is present in such proportions that it can explode when in contact with an ignition source.

Area Classification

Hazardous areas are classified with respect to the potential danger or an explosion, and the areas are divided into zones:

CONDITIONS	CE Code	EC
Continuously Hazardous	Division 1	Zone 0 - An area in which an explosive gas/air mixture is continuously present or is present for long periods.
Periodically Hazardous	Division 1	Zone 1 - An area in which an explosive gas/air mixture is likely to occur under normal operating conditions.
Occasionally Hazardous	Division 2	Zone 2 - An area in which an explosive gas/air mixture is unlikely to occur, but if it occurs, it will be of short duration.

Gases & vapour classification

Gases are grouped together basing on the amount of energy required to ignite the most explosive mixture of the gases with air. Equipment is classified into groups according to the gases and vapours for which it is suitable and must be selected with a grouping, which covers the gases and vapours which, will be present where it is to be installed:

Group	Representative Gas	Ignition Energy
I	Methane	320 Microjoules
IIA	Propane	300 Microjoules
IIIB	Ethylene	160 Microjoules
IIC	Hydrogen	40 Microjoules

GAS	CE CODE	IEC
Acetylene	Class I, Group A	Group IIC
Hydrogen, Butadiene, Ethylene Oxide, Propylene Oxide, or Acrolein	Class I, Group B	Group IIC
Ethylene, Cyclopropane, Ethyl Ether, or Ethylene	Class I, Group C	Group IIB
Propane, Acetone, Alcohol, Ammonia, Benzene, Benzol, Butane, Gasoline, Hexane, Laquer Solvent vapours, Naptha, Natural Gas	Class I, Group D	Group IIA
Coal Mines	Gaseous Mines	Group 1
Combustible Dusts	Class II	
Ignitable Fibres or Flying	Class III	

To ensure the suitability of electrical equipment for use in hazardous areas, the equipment is certified and uses various techniques known as Methods of Protection. As not all Methods of Protection are suitable for all hazardous areas, care must be taken to select equipment, which is suitable for use in the Zone in which it is installed.

Zone 0	Zone 1	Zone 2
Ex ia - Intrinsic safety Ex s - Special protection if specifically certified for Zone 0	Method suitable for Zone 0 Ex ib - Intrinsic Safety Ex d - Flameproof enclosure Ex e - Increased safety Ex m - Encapsulation Ex s - Special protection	Method suitable for Zone 0 or I Ex N - Type of protection N Ex o - Oil immersion* Ex q - Powder filling* Ex p - Pressurised or purging
* may be suitable for Zone 1		

*BriteCell Fast is designed and manufactured by
Tekmar Sistemi Srl
www.tekmar.it*

© Copyright Tekmar Sistemi s.r.l.

This document contains information, which is the property of Tekmar Sistemi S.r.l.
The contents are confidential, any reproduction of all or part of this publication, without the written consent
by Tekmar Sistemi s.r.l is forbidden.

This publication is issued to provide outline information and is not deemed to form any part of any offer
and contract. The company has a policy of continuous product development and improvement and we
therefore reserve the right to vary any information quoted without prior notice.