



**User's manual for  
band or channel selective Remote Unit  
MOR701B Power**

**(Id.-Nos.: 147362/148669)**

Author:

Approved:

QA:

## Table of Contents

<b>LIST OF UNIT SPECIFIC ABBREVIATIONS</b>	<b>6</b>
<b>CONTENTS OF DELIVERY</b>	<b>9</b>
<b>HEALTH AND SAFETY WARNING</b>	<b>10</b>
<b>PREAMBLE</b>	<b>11</b>
<b>1 INTRODUCTION</b>	<b>13</b>
1.1 Intended purpose	13
1.2 About the MOR701B POWER	13
<b>2 FUNCTIONAL DESCRIPTION</b>	<b>14</b>
2.1 General	15
2.2 RF modules	15
2.3 Mother board	17
2.4 Control module SM 2009	18
2.5 Duplexer	19
2.6 Active Combiner	20
2.7 Transceiver MFY1319	20
2.8 FSK modulator	21
2.9 4-way-Splitter	22
2.10 Measuring aids	22
2.11 Power supply	22
2.12 Feed forward amplifier	24

<b>3</b>	<b>FUNCTIONS AND FEATURES</b>	<b>25</b>
3.1	Band and channel selectivity	25
3.2	Gain setting	25
3.3	ALC	26
3.4	BITE and alarms	26
3.4.1	Handling of alarms	28
3.4.2	Status report	29
3.4.3	Severity levels	30
<b>4</b>	<b>OPTIONAL EQUIPMENT</b>	<b>32</b>
4.1	VSWR module	32
4.2	External alarms	32
4.3	Battery backup module	34
<b>5</b>	<b>SPECIFICATION</b>	<b>36</b>
5.1	Electrical specification	36
5.2	Optical specification	38
5.3	Mechanical specification	38
5.4	Environmental and safety	38
5.5	External electrical interfaces	39
5.5.1	Electrical power	39
5.5.2	RF connection	40
5.5.3	Optical connector	40
<b>6</b>	<b>INSTALLATION</b>	<b>41</b>
6.1	Mechanical installation	42
6.2	Electrical installation	45
6.2.1	Grounding	45
6.2.2	Power connection	46
6.2.3	Connection of the antenna cable	46
6.2.4	Connecting fibre optic cables	47

<b>7</b>	<b>SETTING TO WORK</b>	<b>49</b>
7.1	Preparation	49
7.2	Setting of operational parameters	50
7.2.1	Manual setting of the attenuation by means of rotary switches	50
7.2.2	Settings via personal computer as terminal	52
7.2.3	Remote control via Master Unit	54
<b>8</b>	<b>TROUBLE SHOOTING</b>	<b>55</b>
8.1	Error indication	55
1.2	Boot process	55
1.3	Alarm monitoring with the STATUS HIST command	56
1.4	Power supply	56
1.5	General remarks	56
<b>9</b>	<b>MAINTENANCE</b>	<b>57</b>
9.1	General	57
9.2	Replacement of the fuses (mains)	57
9.3	Replacement of the power supply fuse	58
9.4	Replacement of the mains cable	58
9.5	Replacement of the RAM / RTC battery	59
9.6	Replacement of the dummy battery backup module	60
9.7	Replacement of the duplexer	61
9.8	Replacement of RF modules	62
9.9	Replacement of the control module SM 2009	64
9.10	Replacement of power supplies	65
9.11	Replacement of Active Combiner modules	66
9.12	Replacement of feed forward amplifier	67
9.13	Replacement of the FSK modulator	69



<b>9.14</b>	<b>Replacement of the Transceiver MFY1319</b>	<b>69</b>
<b>10</b>	<b>SPARE PARTS LIST</b>	<b>70</b>
<b>11</b>	<b>CONFIGURATION LIST</b>	<b>72</b>
<b>12</b>	<b>APPENDIX</b>	<b>73</b>
<b>12.1</b>	<b>Installation drawing of the Repeater</b>	<b>73</b>
<b>12.2</b>	<b>Top view of the Repeater (left-hand side , four channel configuration)</b>	<b>74</b>
<b>12.3</b>	<b>Top view of the Repeater (right-hand side, four channel configuration)</b>	<b>75</b>
<b>12.4</b>	<b>One channel configuration –block diagram and cabling</b>	<b>76</b>
<b>13</b>	<b>INDEX</b>	<b>78</b>



**LIST OF FIGURES AND TABLES**

table 1-1 List of international sales offices..... 12

figure 2-1 Block diagram of MOR701B Power..... 14

figure 2-2 Top view of an RF module..... 16

figure 2-3 Top view of a mother board..... 17

figure 2-4 Top view of the control module..... 18

figure 2-5 Top view of the duplexer..... 19

figure 2-6 Top view of an Active Combiner module..... 20

figure 2-7 Transceiver MFY1319..... 20

figure 2-8 Installation position of the Transceiver..... 21

figure 2-9 Configuration of the connecting pins..... 21

figure 2-10 Top view of the 4-way-Splitter (Transceiver dismantled)..... 22

figure 2-11 Mounting position of power supplies..... 23

figure 2-12 ON / OFF position of external switch..... 24

figure 2-13 Top view of the feed forward amplifier..... 24

figure 3-1 Position of rotary switches..... 25

figure 3-2 Position of failure LEDs..... 26

figure 3-3 Status hist report..... 27

table 3-4 List of all available alarms..... 28

figure 3-5 Example of a GET1 report..... 29

figure 3-6 Example of a STATUS report..... 30

figure 4-1 Clamps for external alarms..... 32

figure 4-2 Cable configuration and installation position..... 34

figure 4-3 Mounting position of batteries..... 35

figure 5-1 Screw terminal for mains cable..... 39

figure 5-2 Connector panel layout..... 40

figure 6-1 System description..... 41

figure 6-2 Wall mounting brackets..... 43

figure 6-3 Clearance distance..... 44

figure 6-4 Grounding kit..... 45

figure 6-5 Screw terminal..... 46

table 7-1 LED indication..... 49

figure 7-2 Position of the DIP-Switch 1..... 50

figure 7-3 Position of the rotary switches..... 51

figure 7-4 Rotary switches and label..... 51

table 7-5 DIP-switch configuration..... 52

figure 7-6 DIP-switch 2 for local mode..... 52

figure 9-1 Top view of the Repeater..... 57

figure 9-2 Fuse terminal..... 58

figure 9-3 Position of power supply fuse..... 58

figure 9-4 Position of RAM/RTC battery..... 60

figure 9-5 Position of dummy battery backup module..... 61

figure 9-6 Cable configuration of the duplexers..... 61

figure 9-7 Connector panel layout..... 62

figure 9-8 Top view of an RF module..... 63



figure 9-9 Position of hex coded rotary switches..... 64  
table 9-10 Address of synthesizer ..... 64  
figure 9-11 Position of control module ..... 65  
figure 9-12 Power supply..... 65  
figure 9-13 Position of special-nut M4..... 66  
figure 9-14 Position of counter sunk screws on Active Combiner ..... 67  
figure 9-15 Position of the feed forward amplifier reset board ..... 68  
figure 9-16 Position of feed forward amplifier (Right-hand side of Repeater) ..... 68  
figure 9-17 FSK modulator..... 69  
figure 9-18 Installation position..... 69  
table 10-1 Spare parts list ..... 71  
figure 11-1 Sample of a configuration list..... 72  
figure 12-1 Installation drawing of the Repeater ..... 73  
figure 12-2 Top view of the Repeater (left-hand side, four channel configuration)..... 74  
figure 12-3 Top view of the Repeater (right-hand side, four channel configuration)..... 75  
figure 12-4 Block diagram of one channel Repeater ..... 76  
figure 12-5 Cabling of one channel Repeater ..... 77

## LIST OF UNIT SPECIFIC ABBREVIATIONS







ALC	Automatic Level Control
BCCH	Broadcast Control Channel
BITE	Built In Test Equipment
BTS	Base Transceiver Station
DL	Downlink
ETS	European Telecommunication Standard
FFwd	Feed Forward Amplifier
FSK	Frequency Shift Keying
Id.-No.	Ident Number
I <sup>2</sup> C-Bus	Inter Integrated Circuit Bus ( Philips )
LMT	Local Maintenance Timeout
MFY	MIKOM Transceiver
MOR	MIKOM Optical Repeater
OMC	Operation and Maintenance Centre
PABX	Private Automatic Branch Exchange
PCMCIA	Personal Computer Modem Communication International Association
PSTN	Public Switched Telephone Network
Rev	Revision
RF	Radio Frequency
RLP	Radio Link Protocol
RSSI	Receive Signal Strength Indication
RTC	Real Time Clock
SDA	Serial Data Line of I <sup>2</sup> C-Bus
SCL	Serial Clock Line of I <sup>2</sup> C-Bus
UL	Uplink
UPS	Uninterruptable Power Supply
VSWR	Voltage Standing Wave Ratio



## CONTENTS OF DELIVERY

Qty	1	Repeater MOR701B Power
Qty	1	User's manual for Repeater MOR701B Power
Qty	1	Set of test protocols consisting of an electrical acceptance test protocol and a safety test protocol applying to the power supply
Qty	1	Spare parts kit containing: <ul style="list-style-type: none"><li>- 1 control cable RS232,</li><li>- 1 hex socket key, size 2.5</li><li>- 1 Torx key</li><li>- 5 socket head cap screws M3.0 x 30</li><li>- 2 tallow-drop screws TRX M5.0x25</li><li>- 2 tallow-drop screws M2.0x6</li><li>- 2 tallow-drop screws M3.0x5</li><li>- 4 straight pins 3.0 x 25</li><li>- 3 captive washers for M5</li><li>- 4 Tyraps</li><li>- 3x5g Silicon heat conducting paste</li><li>- 1 hex socket screw key , size 4, long</li><li>- 4 nuts</li><li>- 2 fuses 8 A type MT</li><li>- 5 socket head cap screws M3.0x20</li><li>- 2 countersunk head screw M3.0x20</li><li>- 4 special nuts M4</li></ul>
Qty	1	Wall mounting kit <ul style="list-style-type: none"><li>- 2 mounting brackets</li><li>- 4 washers for M8</li><li>- 4 socket head cap screws M8.0x16</li><li>- 2 tire bolts</li></ul>
Qty	1	Wall mounting sheet

## HEALTH AND SAFETY WARNINGS

-  **Note:** The electrical installation has to be performed in accordance with the safety regulations of the local authorities. Due to safety reasons the electrical installation must be performed by qualified personnel. The cover of this unit should not be opened while power is applied. Subsequent installation, commissioning and maintenance activities that require the unit to be powered with the cover open shall only be carried out by suitably qualified personnel.
-  **Note:** The grounding of the Unit has to be performed by all means. A grounding bolt is provided at the cabinet in order to connect the earth bonding cable.
-  **Note:** The Unit is heavy-weight. Make sure that a suitable mounting surface is used. Only adequate manpower is allowed to handle the system.
-  **Note:** ESD precautions have to be observed! Before maintenance work use the available grounding system to connect ESD protection measures.
-  **Note:** Due to power dissipation the Repeater may heat up the air volume inside the cabinet and reach a very high temperature. Therefore the Repeater must be mounted in the vertical plane to a wall or a mast without additional enclosure to provide sufficient ventilation. Between the housing and the wall a minimum distance must be kept in order to provide air circulation.
-  **Note:** Laser radiation! Do not stare into the beam or view directly with optical instruments. Class 3A laser product.

## PREAMBLE

In cellular systems, Repeaters are used to enhance the influence of a base station in regions where, due to topological conditions, poor field strengths disable communication. MIKOM is a leading manufacturer of Repeaters. They provide excellent electrical characteristics, they are light-weight and easy to install. Hence, the MIKOM Repeater is the preferred solution.

Your Repeater has been built using high reliable materials. A comprehensive quality assurance has been applied to all fabrication steps. This secures constant quality of the product. Every Repeater leaves the factory only after a thorough final acceptance test, accompanied by a test certificate, which warrants perfect function. The acceptance test certificate is subject of the delivery, and it is fixed to the Repeater lid in order to provide a quick reference for the user.

Any intervention has to be performed by authorized persons only. If you need technical assistance with the Repeater MOR701B Power approach your local sales office (see table 1-1 List of international sales offices) or MIKOM directly at the following address:

**MIKOM GmbH**  
**Industriering 10**  
**86675 Buchdorf**  
**Germany**  
**Tel: +49 (0) 9099 6 90**  
**Fax: +49 (0) 9099 69 31**  
**email: sales@mikom.com**  
**http://www.mikom.com**

Under consideration of all references given in this manual, the Repeater should be taken into service without any complications and should operate trouble-free for a long time.

---

## LIST OF INTERNATIONAL SALES OFFICES

---

<p><b>Allen Telecom</b></p> <p>30500 Bruce Industrial Parkway Cleveland, Ohio 44 139-3996 USA</p> <p>Phone: +1 ( 216 ) 349-8657 FAX: +1 ( 216 ) 349-8408</p>	<p><b>Allen Telecom (Australia) P/L</b></p> <p>PO Box 903 Bankstown NSW 2200 Australia</p> <p>Phone: +61 ( 2 ) 9793-9644 FAX: +61 ( 2 ) 9793-9747</p>	<p><b>Forem France</b></p> <p>Z.I. des Ebisoires 78370 Plaisir France</p> <p>Phone: +33-1-30-79-15-30 FAX: +33-1-30-55-55-37</p>
<p><b>FOREM S.p.A.</b></p> <p>Via Archimede N. 22/24 20041, Agrate Brianza Milan Italy</p> <p>Phone: +39-39-605-41 FAX: +39-39-605-4477</p>	<p><b>AT Singapore</b></p> <p>80 Marine Parade Road #19-1 Parkway Parade Singapore 449269</p> <p>Phone: +65-345-8022 FAX: +65-345-8033</p>	<p><b>AT China</b></p> <p>CITIC Building, # 11-05 19 Jianguomenwai Avenue Beijing China 100004</p> <p>Phone: +86-10-6508-3088 FAX: +86-10-6508-3066</p>
<p><b>AT Canada</b></p> <p>1815 Ironstone Manor, # 12 Pickering, Ontario L1W 3W9 Canada</p> <p>Phone: +1 ( 905 ) 839-3474 FAX: +1 ( 905 ) 839-4663</p>	<p><b>FOREM UK</b></p> <p>Unit D Castle Industrial Park Pear Tree Lane Newbury, Berkshire U.K. RG 14 2EZ</p> <p>Phone: +44-1635-569-695 FAX: +44-1635-569-463</p>	<p><b>AT Hong Kong</b></p> <p>1603 Remington Certer, 23 Hung to road, Kwun Tong, Kow Loon Hong Kong</p> <p>Phone: +852-2389-1844 FAX: +852-2389-4864</p>
<p><b>AT India</b></p> <p>B-256 Ground Floor. Chittaranjan Park New Delhi 110019</p> <p>Phone: +91-11-696-3918 FAX: +91-11-652-1648</p>		

table 1-1 List of international sales offices

## 1 Introduction

### 1.1 *Intended purpose*

Cellular telephone systems transmit signals in two directions between base stations and mobile telephones within the signal coverage area.

If weak signal transmissions occur within the coverage area because of indoor applications, topological conditions or distance from the transmitter, a Repeater is used to extend transmission range. In the downlink path the Repeater picks up the signal from a donor antenna of an existing cell, amplifies and re-transmits it into the desired dark spot. In the uplink direction the Repeater receives signals from mobile stations present in its coverage area and re-transmits them to the corresponding base station.

### 1.2 *About the MOR701B POWER*

MIKOM's MOR701B Power Remote is available as a band selective optical repeater for GSM, CDMA and TDMA technology and as a channel selective optical repeater for CDMA and TDMA technology.

A GSM channel selective version is available (MOR 740).

The MOR701B Power Remote repeater bi-directionally amplifies signals between multiple mobiles and a single base station in the PCS1900 frequency band using optical fibres for interconnection to a Master Unit. It is employed mainly in tunnels, canyons, and other areas where physical structures cause weak field strengths. It can provide highly selective amplification of band segments or channels in the PCS1900 band.

The MOR701B Power Remote can be combined with other repeaters in order to create a multi-band optical repeater system. Modules operating in GSM1800, GSM900, AMPS800, or iDEN bands are available. When different modules are combined a common antenna and control interface is available.

The MR701 Power Remote can be set-up locally at the Master Unit through the optical fibre or remotely at the OMC. A PCMCIA slot for modem operation is an available option at the Master Unit. The repeater has a large number of functions that can be monitored and changed by the operators via a terminal emulation program or the MIKOM OMC software platform. An easy to understand and simple to learn communication language is available to help the operator query status reports from the repeater or to change settings.

## 2 Functional description

The Repeater MOR701B Power can be equipped from one to four bands or channels.

The following block diagram shall illustrate the configuration of the system.

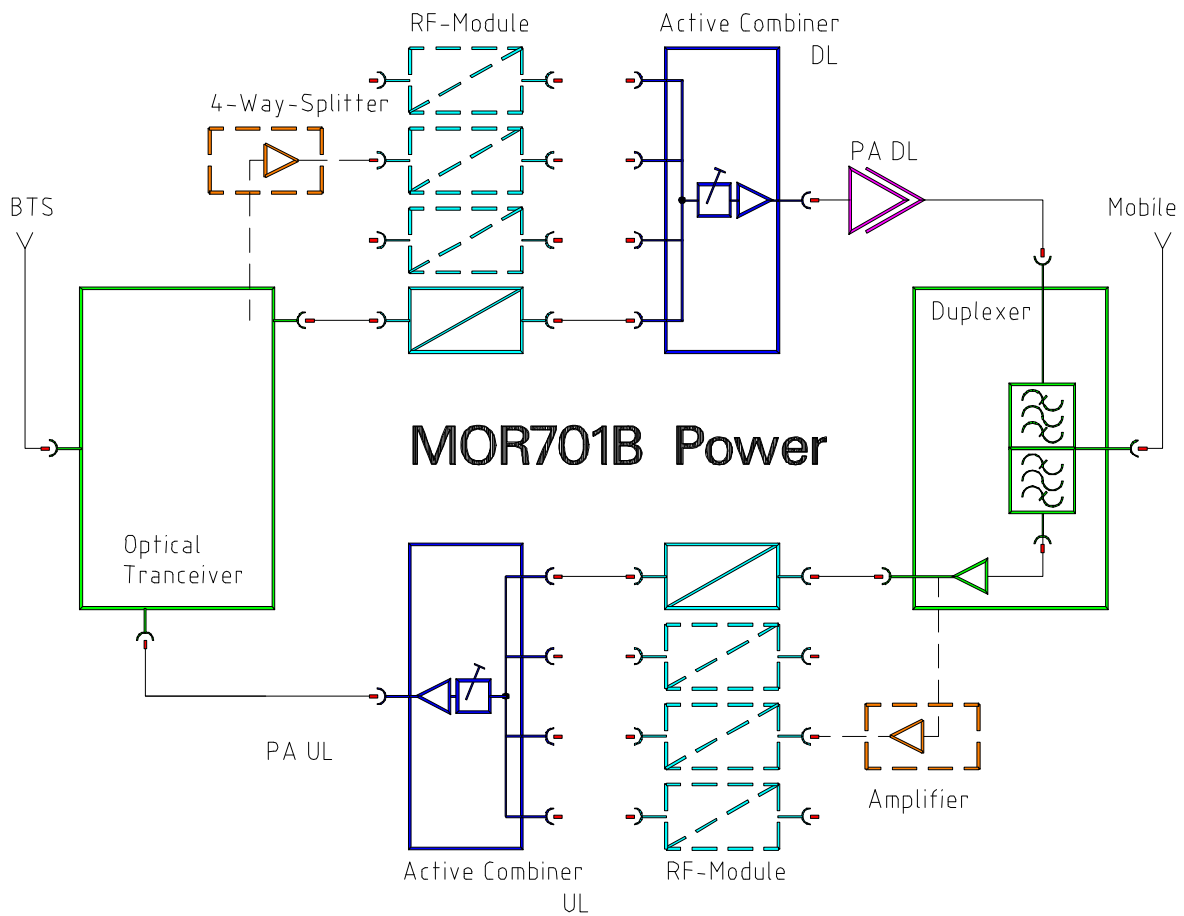

- \*: one physical module contains UL and DL
- \*\* : with more than two channels, the amplifier is included
- \*\*\* For correct cabling see Assembly Guide

figure 2-1 Block diagram of MOR701B Power

## 2.1 General

The Repeater consists of two amplifier chains. The signals to and from the mobiles are combined to an antenna by a frequency separation unit, denominated in the following as Duplexer. The optical signals to and from the Master Unit are converted by the Optical Transceiver.

In the Downlink direction the optical signals from the Master Unit are converted into RF-signals by the Transceiver (see chapter 2.7). They pass the 4-way-Splitter (see chapter 2.9), which provides the RF-signal for the RF modules. After the RF module (see chapter 2.2) they are combined by the Active Combiner (see chapter 2.6) and afterwards amplified by the Feed Forward Amplifier (see chapter 2.12), which provides the required output power. Finally the signals are fed to the antenna by the Duplexer (see chapter 2.5).

In the Uplink direction the signals from the mobiles are separated by the Duplexer, get to a Pre-Amplifier and afterwards to an RF module. The signals are combined by the Active Combiner then, get converted into optical signals by the Transceiver (see chapter 2.7) and are finally transmitted to the Master Unit.

In the final amplifier of the Downlink a power detection measures the output power and controls the gain. In the Uplink the gain is controlled by the Active Combiner to protect the Optical Transceiver. This power detection is called Automatic Level Control (ALC) (see chapter 3.3).

## 2.2 RF modules

The task of the RF modules is to amplify the receive signals and to convert them into an intermediate frequency. The signals, then, proceed a filter stage comprising of highly selective filters, and run through a digital controllable attenuator. The attenuation can be set in steps of 2 dB, locally or remotely. By using the same synthesizer frequency, that was used to convert the signals down to intermediate frequency, the intermediate frequency is mixed up to the original frequency.

The synthesizer is controlled via an I<sup>2</sup>C-Bus. In case of a breakdown in mains, gain and frequency data are non-volatile stored in an EEPROM on board.

See figure 2-2 Top view of an RF module for an exemplary channel or band module.

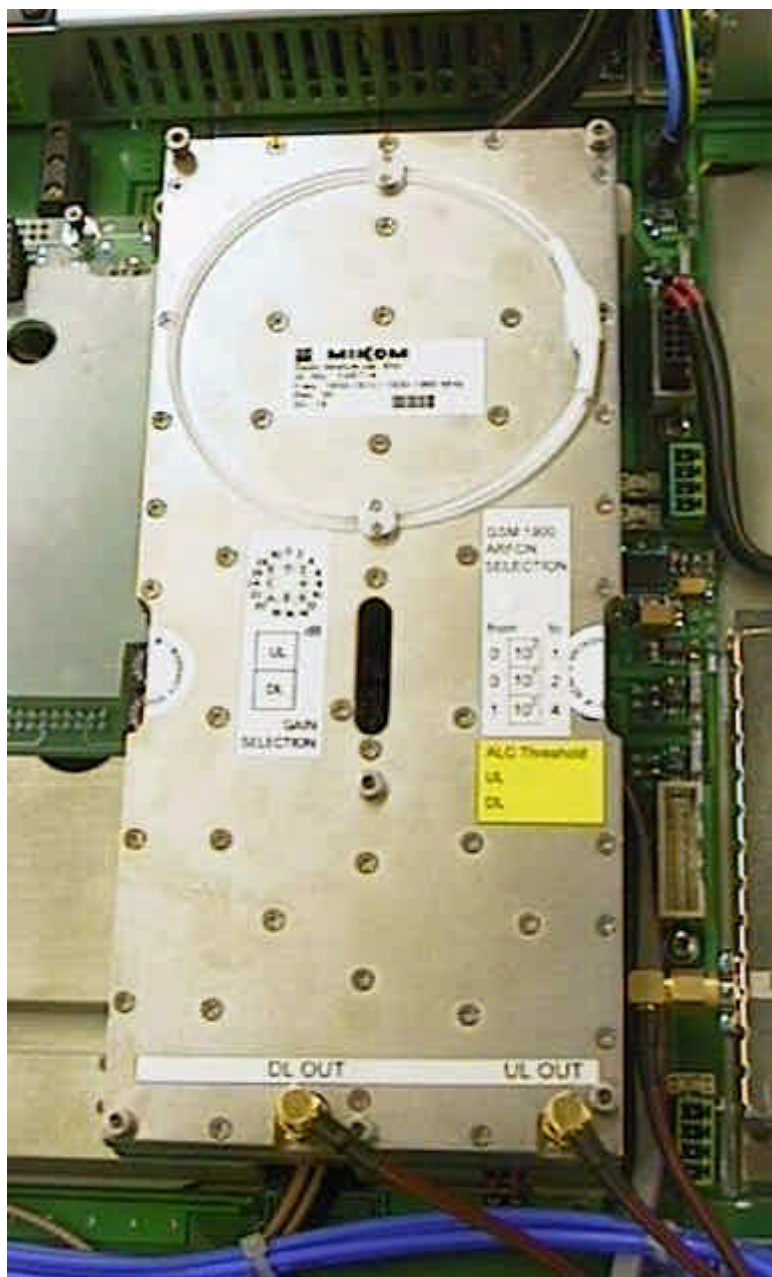

figure 2-2 Top view of an RF module



### 2.3 Mother board

The function of the mother board is the communication between the RF modules and the control module via the I<sup>2</sup>C-Bus.

In the three and four channel configuration of the Repeater there is a mother board on the left- and on the right-hand side, whereas in the one and two channel configuration there is only one mother board implemented on the right-hand side of the Repeater.

Mother boards are located underneath the RF modules.

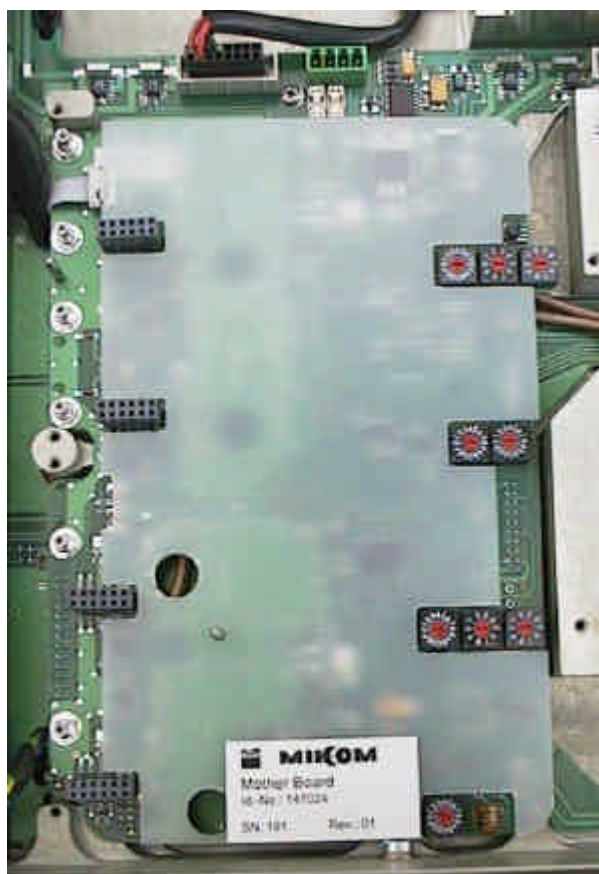

figure 2-3 Top view of a mother board

## 2.4 Control module SM 2009

The control module SM 2009 is a DOS compatible micro computer. The whole communication between the operator and the Repeater can be done via the control module. By using the RS232 interface the Repeater can be controlled locally by using a VT100 terminal, or a PC emulating the VT100 terminal.

Frequency and gain, power down of RF stages and ALC can be controlled and status messages can be received remotely via the Master Unit.

The data transfer between the control module SM 2009 and the mother board is realized by the I<sup>2</sup>C-Bus system.

The I<sup>2</sup>C-Bus concept was developed by Philips for the serial connection of integrated circuits within one device. Two wires, SDA - serial data and SCL - serial clock, carry data between the devices connected to the bus. Each device is recognized by a unique address and can operate either as transmitter or receiver.

All MOR701B Power configuration parameters are stored in an EEPROM on the control module if a power supply failure occurs.

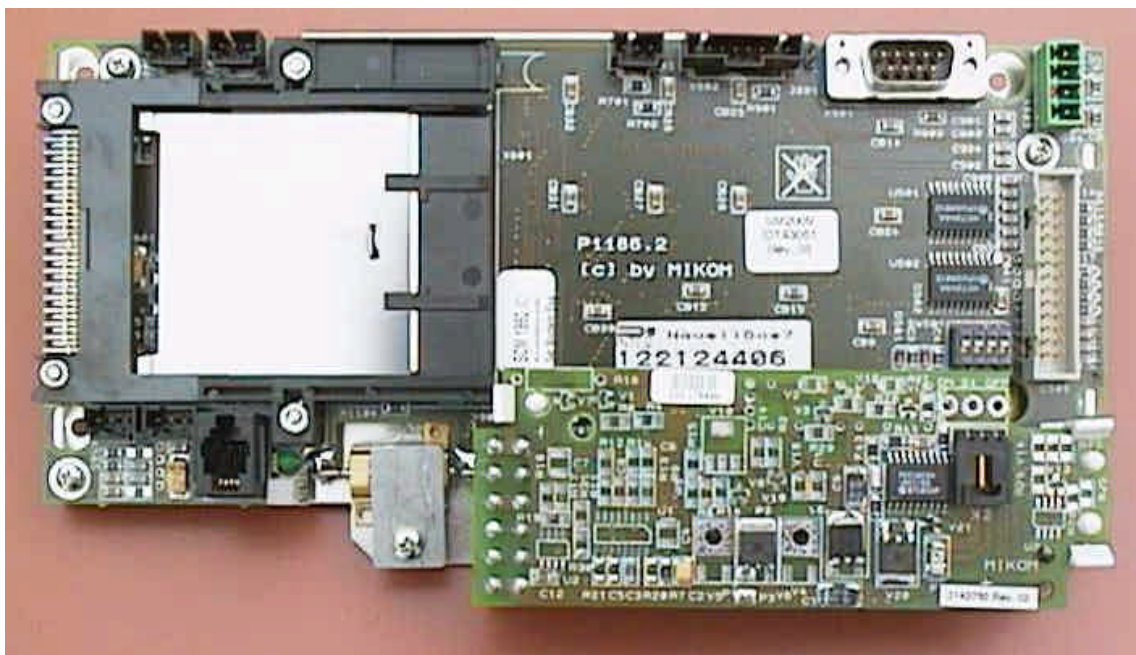

figure 2-4 Top view of the control module

## 2.5 Duplexer

The task of the duplexer is to isolate uplink from downlink, i.e. isolate transmit path from receive path. The pass bandwidth of the duplexer is the entire width of the uplink band and the downlink band.

Two frequency - dependent versions of the MOR701B Power are available:

<b>Id - No</b>	<b>UL frequency</b>	<b>DL frequency</b>
147362	1850 - 1885 MHz	1930 - 1965 MHz
148669	1875 - 1910 MHz	1955 - 1990 MHz

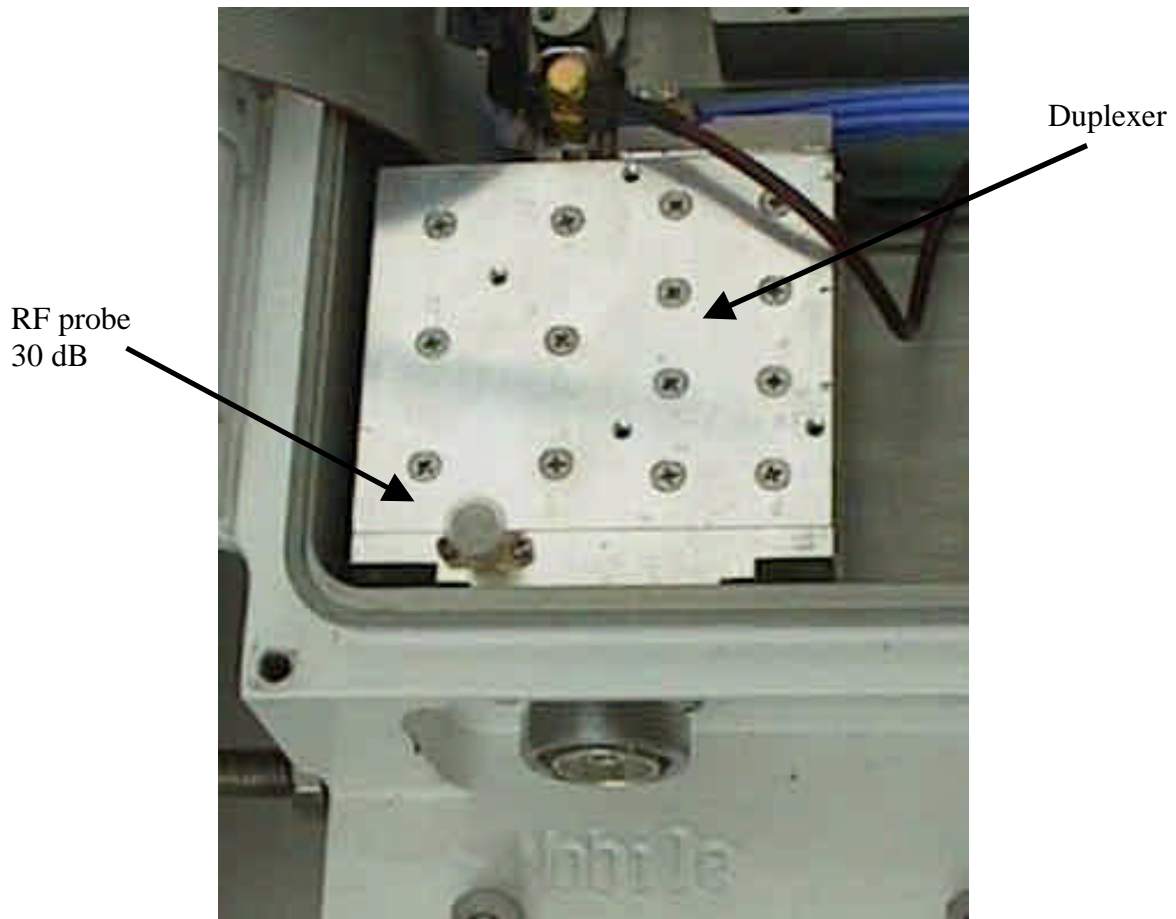

figure 2-5 Top view of the duplexer

## 2.6 Active Combiner

After passing through the RF modules, the signals will be combined by the Active Combiner module in the UL and in the DL path. The Active Combiner will be followed by the feed forward amplifier in the DL and by the Transceiver in the UL.

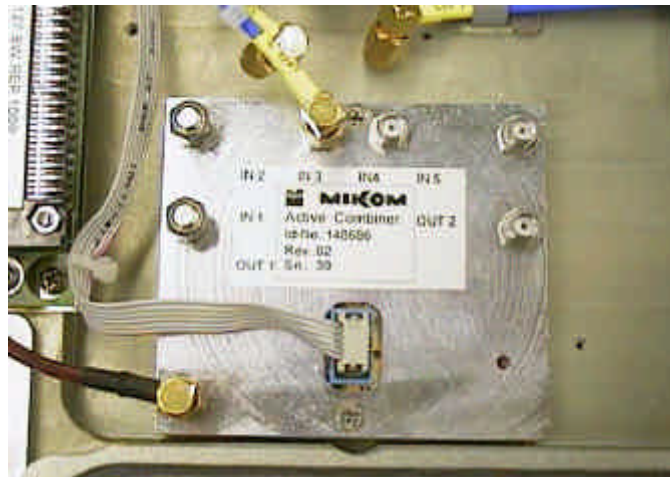

figure 2-6 Top view of an Active Combiner module

## 2.7 Transceiver MFY1319

The Transceiver MFY1319 is the interface between the optic and the electrical distribution unit. The function of the Transceiver is to convert the optical signal into an electrical signal and vice versa.

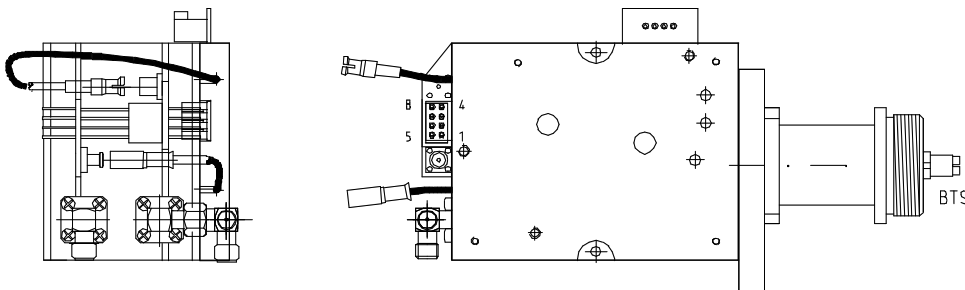

figure 2-7 Transceiver MFY1319

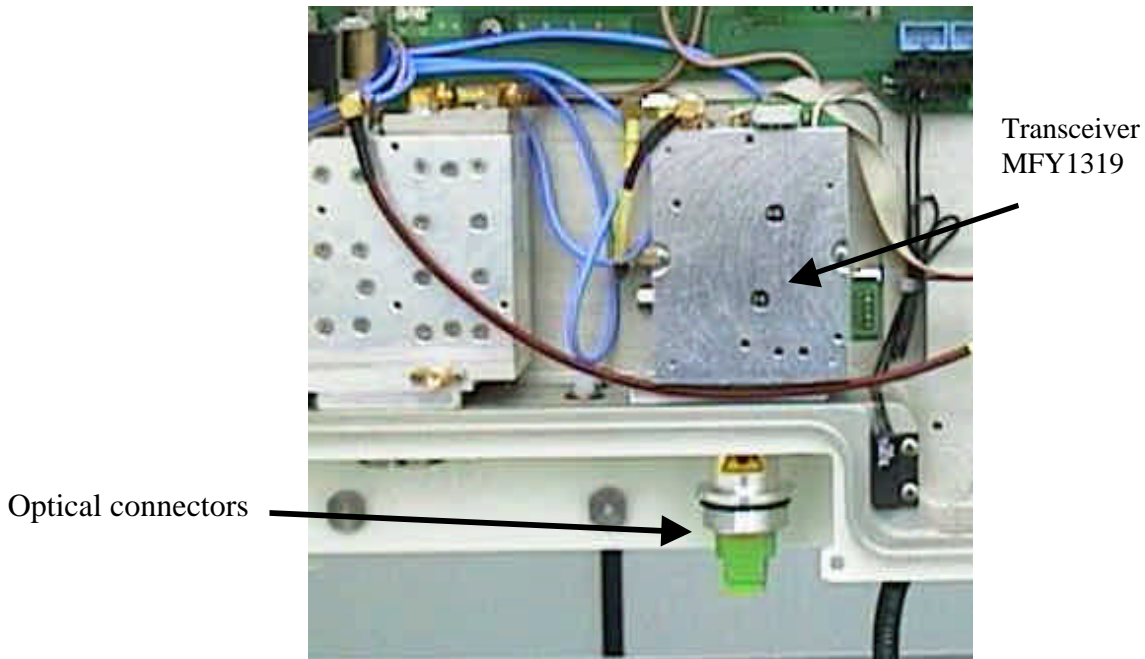

figure 2-8 Installation position of the Transceiver

The configuration of the connecting pins is shown in the following figure.

- Pin 1 GND
- Pin 2 Rx Alarm normally closed
- Pin 3 Tx Alarm common
- Pin 4 Vcc
- Pin 5 Rx Alarm common
- Pin 6 Rx Alarm normally open
- Pin 7 Tx Alarm normally closed
- Pin 8 Tx Alarm normally open

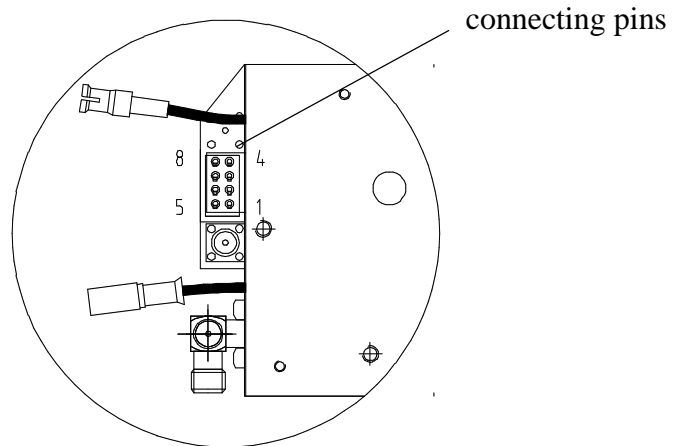

figure 2-9 Configuration of the connecting pins

## 2.8 FSK modulator

To enable remote control between the Master Unit and the Remote Units a serial interface will be implemented, in the following designated as FSK modulator. Signals from the Remote Unit will be modulated to a 10.7 MHz carrier and are fed to the optical Transceiver to be transmitted to the Master Unit via optical fibre and vice versa.

## 2.9 4-way-Splitter

The 4-way-Splitter provides the RF-signal to the RF modules. It splits up the signal from the Receiver and provides four equal RF outputs with an attenuation of 10 dB for the RF modules. It is mounted underneath the Optical Transceiver and can be seen only, if the Transceiver is dismantled.



figure 2-10 Top view of the 4-way-Splitter (Transceiver dismantled)

## 2.10 Measuring aids

With the built-in RF probe test signals can be applied or detected. The duplexer is equipped with a probe which provides a coupling factor of 30 dB. This facilitates measurements under all operational conditions, while an antenna or a dummy load may be connected.

The position of the coupler on the duplexer is shown in figure 2-5 Top view of the duplexer.

## 2.11 Power supply

For the MOR701B Power three power supplies are necessary. Power supplies are available with different mains power. See list below for available power supplies.

- 115 VAC  $\pm$  15% / 40 - 65 Hz
- 230 VAC  $\pm$  15% / 40 - 65 Hz
- 185 - 320 VAC / 40 - 65 Hz
- 24 VDC
- 42 to 60 VDC
- 80 to 130 VDC

The following figure shows the mounting position of the power supplies in the MOR701B Power cabinet.

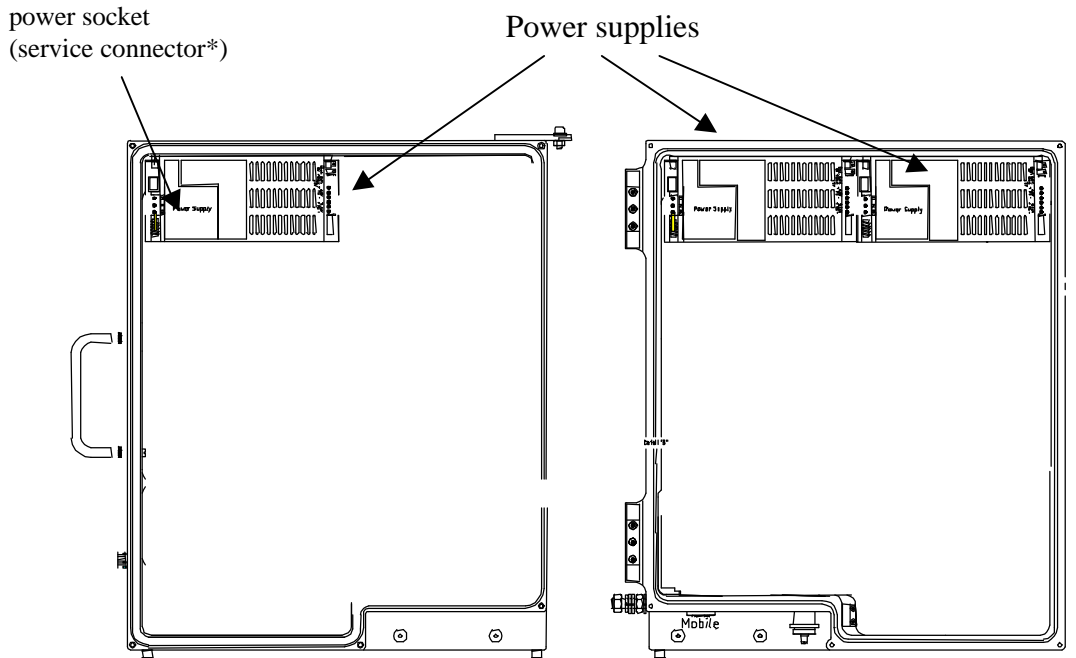

\* service connector is not included in each power supply

G0850M0

figure 2-11 Mounting position of power supplies

The power supplies are equipped with a power socket, protected with two fuses. Each power supply can be switched on or off by means of an external switch. The modules of the Repeater are voltage free if all power supplies are switched off. The power socket, however, is still provided with mains power.

See figure 2-12 ON / OFF position of external switch.

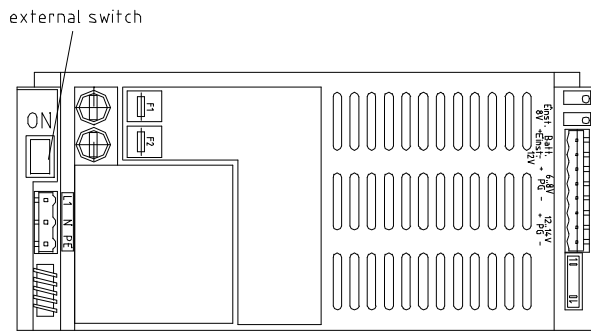

figure 2-12 ON / OFF position of external switch

**Note:** To switch the whole Repeater voltage free, you have to remove the fuses F1 and F2 on the screw terminal.

The power supply is factory-set.

## 2.12 Feed forward amplifier

The feed forward amplifier is the final stage which enables high output power as well as a high ICP3. One amplifier is installed for the DL Out path.



figure 2-13 Top view of the feed forward amplifier



### 3 Functions and features

#### 3.1 Band and channel selectivity

The selectivity is achieved by highly selective filters in the IF part of the band / channel modules.

#### 3.2 Gain setting

The gain can be changed by introducing attenuation into the amplifier chain. By using a rotary switch the attenuation can be adjusted locally in the range from 0 dB to 30 dB maximum in steps of 2 dB. The attenuation can be set for the UL and DL path separately.

The rotary switches are mounted on the mother board. These switches are accessible through the long hole between the two RF modules (see figure 3-1 Position of rotary switches). They can be adjusted easily by means of a small screwdriver.

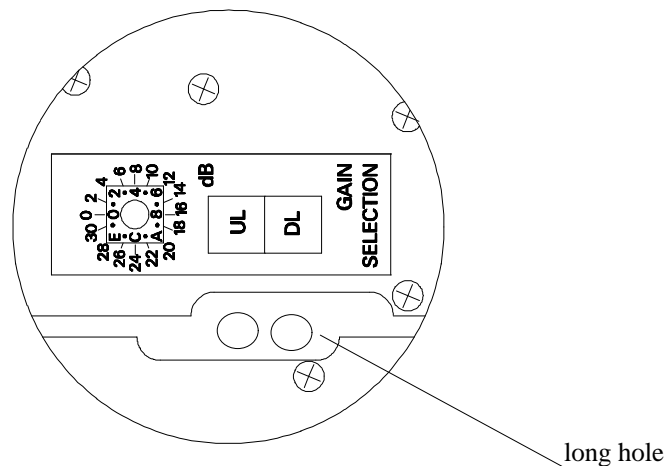

figure 3-1 Position of rotary switches

For remote control an RS232 interface can be used to set the gain.

The functions of the control module may be used locally by means of a VT100 terminal or a personal computer emulating the VT100 terminal. See also chapter 7.2, which deals with settings of operational parameters.

### 3.3 ALC

In order to protect the final amplifier and the optical devices from overload and to prevent the system to generate spurious emission, the amplifier for the DL Out and the Active Combiner for the UL Out have an Automatic Level Control, designed to limit the output power to a defined level. A part of the output power is rectified, amplified and used to control an attenuator network. In order to avoid oscillation, the control amplifier has an integrating characteristic, so that a step function response obtains a delayed rise and decay.

**Note:** The ALC protects the final amplifier and the optical devices. To keep spurious emissions below certain limits, the input power into the Repeater and the attenuation settings of the Repeater have to be considered properly.

### 3.4 BITE and alarms

The Built-In TEst concept comprises the monitoring of the power supplies, the operational currents in the RF modules, the mother board and the remote control interface. Furthermore, the synthesizer lock and the temperature of the Repeater are monitored.

There are three multicoloured LEDs mounted on the control module. The LED L3 indicates the presence of electrical power of +12VDC in the Repeater. Every alarm is indicated by the failure LEDs, L1 and L2.

Position of the LEDs on the control module is shown in the following figure.

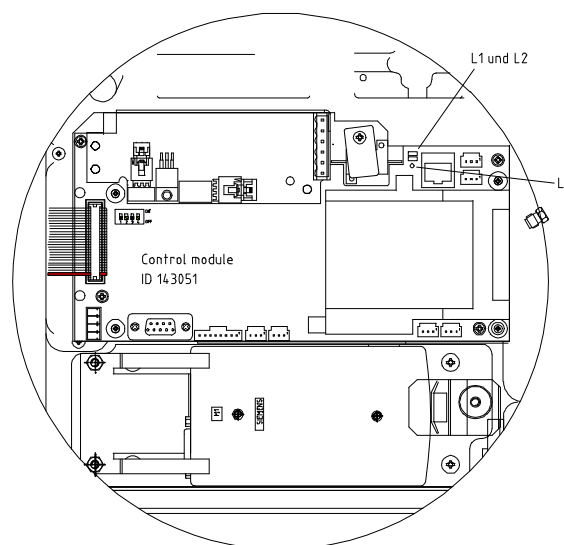

figure 3-2 Position of failure LEDs

All alarms can be checked by typing the 'STATUS HIST' command. It is possible to cancel minor alarms with no influence on the system by typing the 'ALARMACKN' command, e.g. ALC active, VSWR or door open. The following print screen illustrates a possible 'STATUS HIST' report

```

Winterm - Winterm.scw
File Edit Connection Transfer Settings Help
NIKON > status hist
NIKON HISTORY OF ALARMS :
03-03-1997 16:23:22 : POWER SUPPLY 80V FAILURE
03-03-1997 16:23:22 : POWER SUPPLY 120V FAILURE
03-03-1997 16:23:22 : MAINS FAILURE
03-03-1997 16:23:23 : DOOR OPEN
03-03-1997 16:23:24 : ALC FAILURE
NIKON >
NIKON >
NIKON > alarmackn
ALARM ACKNOWLEDGED
NIKON >
NIKON >
NIKON > status hist
NIKON HISTORY OF ALARMS :
03-03-1997 16:23:22 : POWER SUPPLY 80V FAILURE - ACK
03-03-1997 16:23:22 : POWER SUPPLY 120V FAILURE - ACK
03-03-1997 16:23:22 : MAINS FAILURE - ACK
03-03-1997 16:23:23 : DOOR OPEN FAILURE - ACK
03-03-1997 16:23:24 : ALC FAILURE - ACK
NIKON >
Press Alt to access the menu, or click a button
1:04:11 9600 COM1:

```

figure 3-3 Status hist report

In case a hardware failure is detected the concerning hardware module has to be replaced. An alarm can be acknowledged manually by software command. If all alarms have been acknowledged the summary error LEDs are set back to green indication.

In case of mains power failure all data of the STATUS HIST list are lost.

The alarm can also be sent to the OMC.

The following list comprises all available alarms in the Repeater. These alarms may occur in the STATUS HIST list.

NO.	ALARM NAME	ALARM ACTIVE STATUS
1	AMPLIFIER BIAS	FAILURE
2	POWER SUPPLY 8 V	FAILURE
3	POWER SUPPLY 12 V	FAILURE
4	MAINS	FAILURE
5	SYNTH	FAILURE
6	DOOR	OPEN
(7)	VSWR	ALARM
8	ALC	FAILURE
9	LITHIUM BATTERY VOLTAGE	LOW
10	OVERTEMP	
11	INVALID LOGIN ATTEMPT	
12	I2C BUS	FAILURE
(13*)	EXT. ALARM 1	FAILURE
(14*)	EXT. ALARM 2	FAILURE
(15*)	EXT. ALARM 3	FAILURE
(16*)	EXT. ALARM 4	FAILURE
(17**)	EXT. BATTERY	OVERTEMP.

\* Alarm default settings changeable by software instruction SET ALIAS.

\*\* This alarm may be activated together with the external alarms, for instance UPS temperature

(...) Optional alarms

table 3-4 List of all available alarms

### 3.4.1 Handling of alarms

As soon as the software recognizes a valid alarm, a message is transmitted to the Master Unit.

If the reason for the alarm has been cleared or if the alarm should continue, a new alarm message will not be repeated. If there was an interruption of at least one second after acknowledgement, a new alarm message will be generated.

### 3.4.2 Status report

Two instructions enable the operator to gain knowledge of the system status. Typing the GET command will be responded by a listing of all settings of the Repeater. STATUS will be responded by a listing of all individual status information.

An example is listed below for a GET1\* (REP1009V1.xx) and STATUS report. The listing contains random data to demonstrate in which way these messages appear.

\*: Due to the fact that the report is very long, the GET report can be split in two parts. You have to type GET1 to see the first and GET2 to see the second part.

The complete listing of the dialogue language with the processor of the control module including the instructions to and the messages from the system is available as a separate manual.

```

COM2 9600 v.1.1
get1

***GET***
REPEATER ID : MİKOM
MODEM INITSTRING : AT&FE0S0=2
DIALMETHOD : TONE DIALING
PHONE NUMBER 1 : 0
PHONE NUMBER 2 : 0
REP CYCLE : 10 min
TIMEOUT FOR LMT : 28 min
LOCAL-INTERFACE : 9600 bps, 8 bits, NO PARITY
TIME : 14:27:23
DATE : 10-12-1998
BAND-MODULE 1 2 3 4 5 6 7 8
CF UL [MHz] : 833.5
CF DL [MHz] : 880.5
CFO UL [KHz] : 0
CFO DL [KHz] : 0
ATT UL [dB] : 0
ATT DL [dB] : 0
PWR DOWN MODE : DIS
ALC THRESHOLD UL : 255
ALC THRESHOLD DL : 255
TYPE GET2 FOR MORE
MIKOM >
  
```

figure 3-5 Example of a GET1 report

```

CQM2 9600 v.3.1
STATUS
*** STATUS ***
PWR-SUPPLY-MAINS: OK
PWR-SUPPLY-8V : OK
PWR-SUPPLY-12V : OK
LITHIUM-BATTERY : OK
ACCU-VOLTAGE-L1 : OK
ACCU-VOLTAGE-L2 : OK
EXT. ALARM 1 OK
EXT. ALARM 2 OK
EXT. ALARM 3 FAILURE <WAR>
EXT. ALARM 4 FAILURE <WAR>
PASSWORD : OK
VSWR : OK
BAND-MODULE 1 2 3 4 5 6 7 8
CURRENT-AT-8V : OK
CURRENT-AT-12V : OK
SYNTH-LOCK-UL : FAIL <CRI>
SYNTH-LOCK-DL : FAIL <CRI>
ALC-UL : OK
ALC-DL : OK
TEMP [deg C] : 55
DOOR : OPEN <WAR>
MIKOM >

```

figure 3-6 Example of a STATUS report

### 3.4.3 Severity levels

This parameter defines five severity levels for an alarm and can be set in the alarm mask (detailed description in the software manual). The severity levels indicate how the capability of the managed object has been affected.

The levels are described below and are ordered from most severe to least severe:

- Critical: The critical severity level indicates that a service affecting condition has occurred and an immediate corrective action is required to restore the capability of the managed object.
- Major: The major severity level indicates that a service affecting condition has developed and an urgent corrective action is required. Such a severity can be reported, for example, when there is a severe degradation in the capability of the managed object and its full capability must be restored.
- Minor: The minor severity level indicates the existence of a non-service affecting fault condition and that corrective actions should be taken in order to prevent a more serious failure. Such a severity can be reported, for example, when the detected alarm condition is not currently degrading the capability of the managed object.



- Warning: The warning severity level indicates the detection of a potential or impending service affecting failure before any significant effect has been caused. Action should be taken to further diagnose and correction of the problem shall prevent a more serious service affecting failure.
  
- Disable: The disable severity level indicates that the detected failure has no influence on the system and shall not be sent to the terminal.

## 4 Optional equipment

The following modules can be integrated as an option.

### 4.1 VSWR module

VSWR signal is continually measured by a special VSWR module. An alarm can be given for VSWR < 10 dB.

### 4.2 External alarms

With the following option it is possible to monitor 4 external alarms via the Repeater software. Hence the status of the connected device, e.g. UPS, can be monitored.

The contacts of the alarms can be accessed at clamps on the main board (right-hand side of the Repeater).

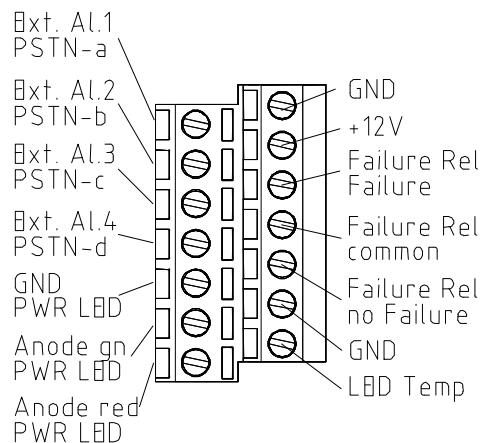

figure 4-1 Clamps for external alarms



The electrical connection has to be as follows.

- External alarm 1 (low active)
- External alarm 2 (low active)
- External alarm 3 (high active)
- External alarm 4 (high active)
- Ground

Configuration: 5 V / 0.5 mA max. for open collector applications.

All external alarms are normally high without connection. Due to the fact that the external alarms 3 and 4 are high active, they have to be connected to ground to prevent an alarm message.

The factory-set response after typing the software command STATUS EXTALARM is for instance „EXT. ALARM 1 OK“, if the alarm is not active and „EXT. ALARM 1 FAILURE“, if the alarm is active.

The name for each external alarm and the name for the alarm message can be defined by the customer with the corresponding software command.

The following example describes the response for the external alarms to control a UPS.

Example:                    External alarms if the UPS is active

```
EXTERNAL ALARM STATUS
UPS alarm active
Battery low !
UPS door open
Battery door open
```

or                    External alarms if the UPS is not active

```
EXTERNAL ALARM STATUS
UPS not active
Battery OK
UPS door closed
Battery door closed
```

For the DC wiring an additional cable bridge has to be installed on the control module (see figure 4-2 Cable configuration and installation position).

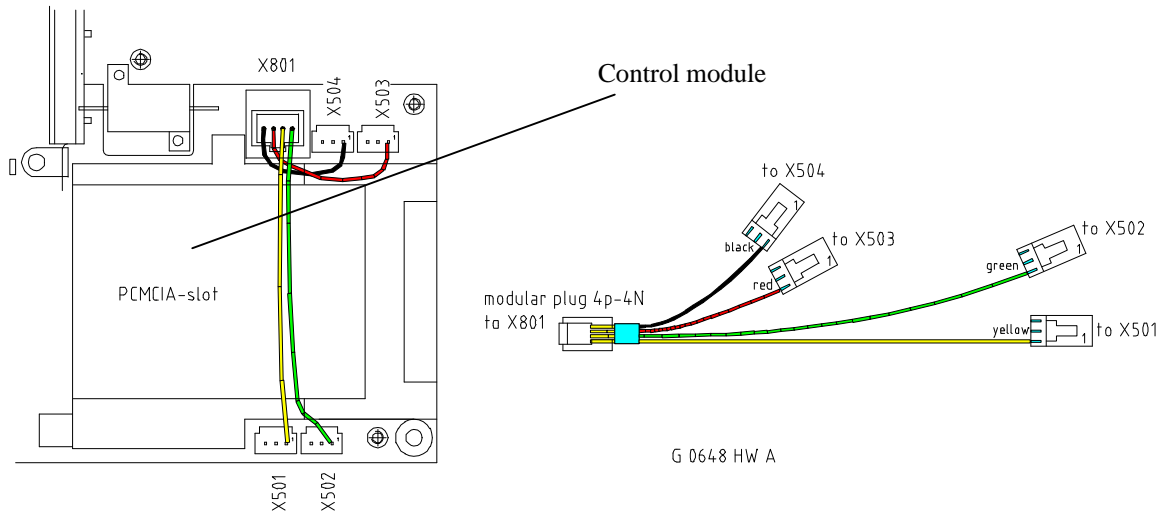

Configuration on the control module SM 2009

figure 4-2 Cable configuration and installation position

### 4.3 Battery backup module

If backup is required only for the control module, low capacity batteries are available to operate the controller for at least ten minutes under normal environmental conditions.

Battery backup is provided for the control module to transmit alarm information in case of power failure. The battery type is a NiCd 8.4V/300 mAh.

**Note:** This battery backup module is provided for the control module only.

The batteries are protected from deep discharge by use of a low voltage disconnect circuit. A local switch is provided to disconnect the battery backup system during maintenance to ensure that all circuits are voltage-free.

The switch is located on the battery backup module.

Switch	ON ( default )	OFF
	Battery backup active	Battery backup not active

The module is directly plugged into the control module. During the charging process a green LED V7 on the module indicates, that the battery is charged at the moment. After finishing the process the LED V7 will be switched off.

The batteries are mounted underneath the modem mounting plate (see following figure).

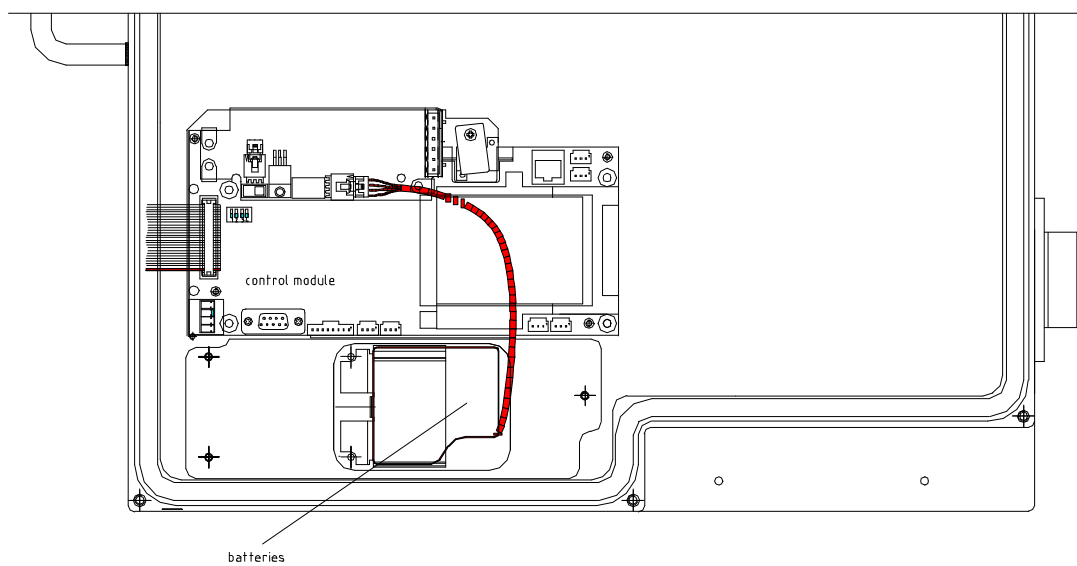

figure 4-3 Mounting position of batteries

## 5 Specification

### 5.1 Electrical specification

Frequency range	UL: 1850 - 1885 MHz; DL: 1930 - 1965 MHz UL: 1875 - 1910 MHz; DL: 1955 - 1990 MHz
Useable bandwidth	35 MHz in the upper or lower PCS1900 band
Gain	65 dB
Gain variation over frequency and temperature*	$\pm 2.5$ dB ( $\pm 3.5$ dB at extreme temperatures)
Gain adjust range	30 dB in 2 dB steps
Gain adjust range tolerance	$\pm 0.5$ dB
Return loss	15 dB @ 25°C ambient temperature
Spurious/intermodulation	-13 dBm max
Spectral re-growth (CDMA only)	-45 dBc (J-STD-008)
Power supply	115 VAC $\pm 15\%$ / 40 - 65 Hz <i>Option:</i> 230 VAC $\pm 15\%$ / 40 - 65 Hz <i>Option:</i> 185 - 320 VAC / 40 - 65 Hz <i>Option:</i> 24 VDC <i>Option:</i> 42 to 60 VDC
RF connector	7/16 female <i>Option:</i> N female
Environmental and safety	See separate leaflet

\*: Normal temperature range +5° to +40°C; Extreme temperature range -33° to +50°C

## BAND AND CHANNEL SPECIFICATIONS

	Option I (fixed bw)	Option II (fixed bw)	Option III (variable bw)	Channel	
				CDMA	TDMA
<b>3 dB bandwidth</b>	5 MHz	15 MHz	0.1 to 15 MHz	1.23 MHz	30 kHz
<b>Slope 3 dB to 30 dB</b>	1 MHz	2 MHz	2 MHz	-	-
<b>30 dB bandwidth</b>	-	-	-	$f_c \pm 900\text{kHz}$	$f_c \pm 60\text{ kHz}$
<b>50 dB bandwidth</b>	-	-	-	$f_c \pm 1.5\text{ MHz}$	$f_c \pm 120\text{ kHz}$
<b>Delay</b>	6 $\mu\text{s}$	3 $\mu\text{s}$	6 $\mu\text{s}$	< 6 $\mu\text{s}$	20 $\mu\text{s}$
<b>Delay variation (typical)</b>	$\pm 150\text{ ns}$	$\pm 150\text{ ns}$	$\pm 150\text{ ns}$	$\pm 500\text{ ns}$	$\pm 500\text{ ns}$
<b>Far off selectivity</b>	40 dB	40 dB	40 dB	60 dB	55 dB
<b>NF at Gmax</b>	6 dB	6 dB	8 dB	6 dB	6 dB
<b>NF at Gmax-30 dB</b>	12 dB	12 dB	13 dB	12 dB	12 dB
<b>OICP-3 at Gmax</b>	59.0 dBm	59.0 dBm	59.0 dBm	59.0 dBm	59.0 dBm
<b>OICP-3 at Gmax - 10 dB</b>	58.6 dBm	58.5 dBm	58.5 dBm	58.5 dBm	59.0 dBm
<b>OICP-3 at Gmax - 20 dB</b>	58.0 dBm	58.0 dBm	57.5 dBm	58.0 dBm	58.5 dBm
<b>OICP-3 at Gmax - 30 dB</b>	56.0 dBm	56.0 dBm	53.0 dBm	55.0 dBm	57.0 dBm
<b>Output noise in band at Gmax</b>	-78 dBm/Hz	-78 dBm/Hz	-76 dBm/Hz	-	-
<b>Output noise out of band at Gmax</b>	-98 dBm/Hz	-98 dBm/Hz	-96 dBm/Hz	-	-
<b>Power consumption standby/max power</b>					
<b>1 module (typ.cons)</b>	130/220W	130/220W	145/220W	130/210W	130/210W
<b>4 modules (typ.cons)</b>	160/250W	160/250W	180/270W	160/240W	160/240W

All data is subject to change without notice !

## 5.2 Optical specification

Max. allowed optical loss Master / Remote	10 dB*
	*optical loss up to 13 dB with slightly degraded specifications
Required optical return loss reflection + backscatter	45 dB

## 5.3 Mechanical specification

### Standard cabinet

Max. Height x Width x Depth:	21.1 x 18.2 x 7.9 inches 535 x 462.5 x 200 mm
Volume:	approximately 45 litres
Weight:	approximately 103 lbs (47 kg per unit in standard configuration)

The illustration of chapter 12.1 provides the dimensions and the view of the layout.

## 5.4 Environmental and safety

For detailed information refer to the environmental and safety specification leaflet for MIKOM indoor / outdoor cell enhancers, related to ETS 300019 (European Telecommunication Standard).

Operating temperature (normal temperature range):	+ 5° C ... + 40° C
(extreme temperature range):	- 33° C ... + 50° C
Humidity:	+ 30° C/ 93 %

## 5.5 External electrical interfaces

### 5.5.1 Electrical power

The Repeater MOR701B Power can be supplied with the following power supplies (mains):

- 115 Vac  $\pm$  15% 40 - 65 Hz
- 230 V ac  $\pm$  15% 40 - 65 Hz
- 185 - 320 Vac 40 - 65 Hz
- 24 Vdc
- $\pm$ 42 to  $\pm$ 60 Vdc
- $\pm$ 80 to  $\pm$ 130 Vdc

A firmly installed mains cable is used, which is fed into the housing through a watertight cable gland. Due to safety reasons the power supply lead has to be protected by two 8 A fuses. Inside the Repeater, mains are connected to a screw terminal.

See figure 5-1 Screw terminal for mains cable for the position of the two 8 A fuses.

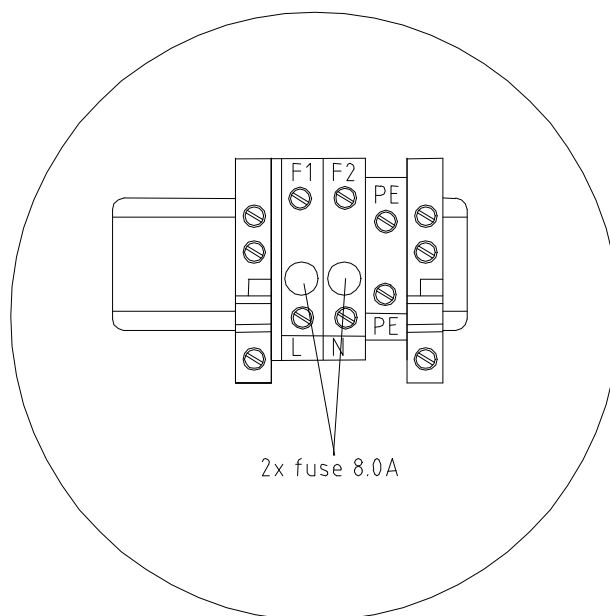

figure 5-1 Screw terminal for mains cable

### 5.5.2 RF connection

There is a 7/16 female antenna connector at the outside of the housing accessible on the connector panel.

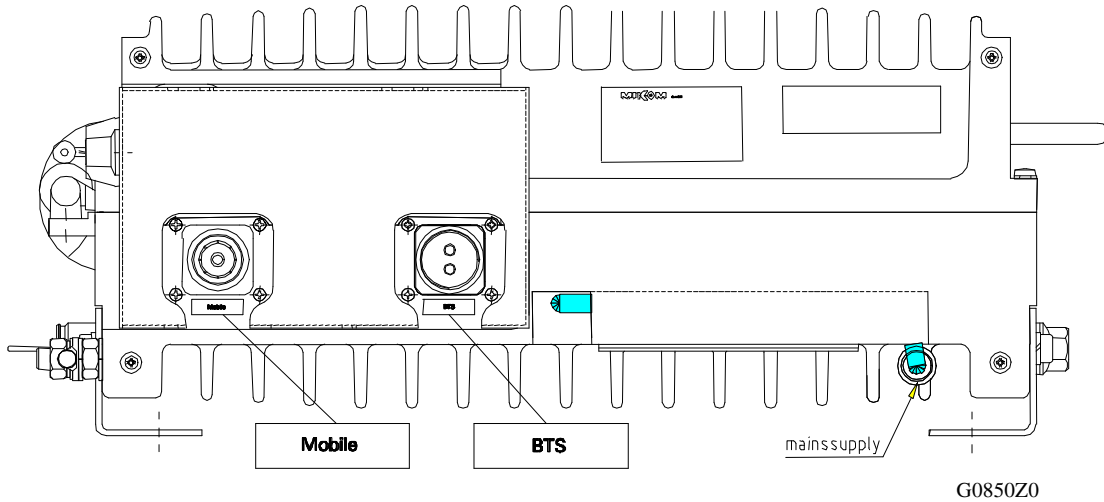
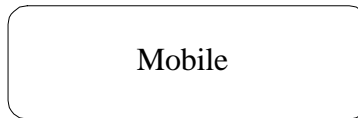

figure 5-2 Connector panel layout

The 7/16 TX-downlink connector should be connected to the antenna system for the communication with the mobile units.



As an option a 7/16 - N adapter is available.

### 5.5.3 Optical connector

The Remote Unit is connected to the Master Unit via optical fibres. Therefore two optical connectors (DIN, SC/APC or FC/APC) are available at the front side of the Repeater. They are labelled with RX and TX.





## 6 Installation

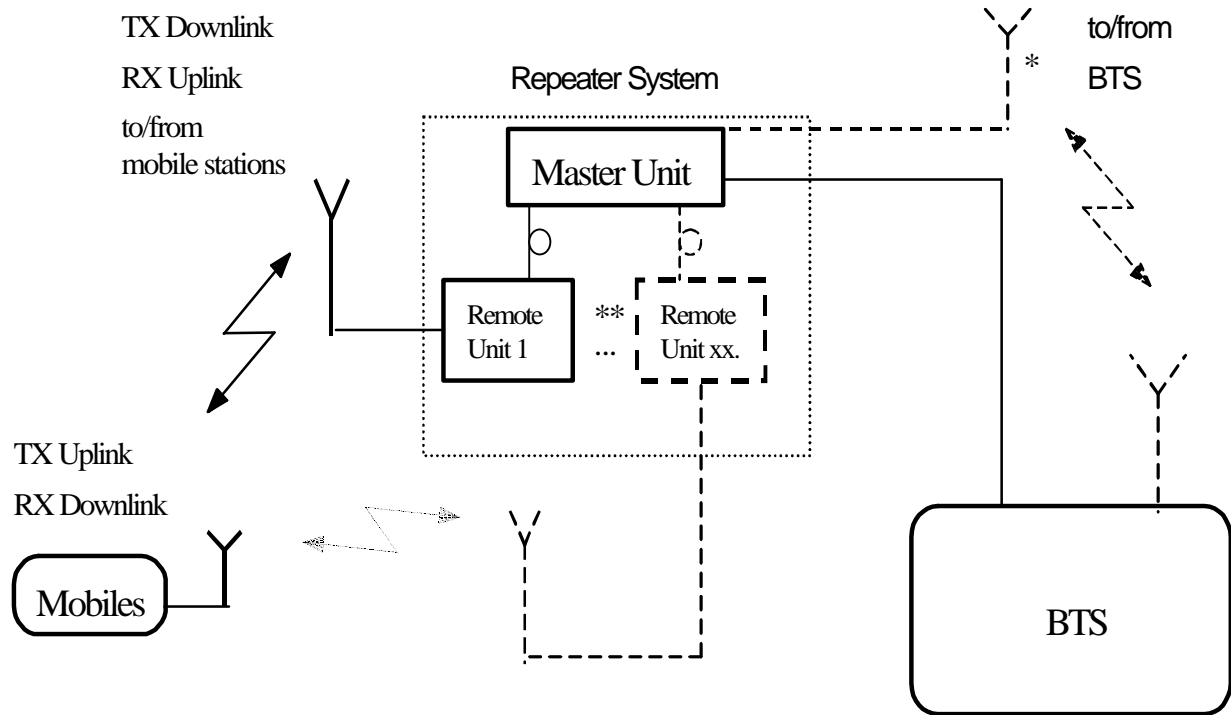

\*: This is possible alternatively

\*\* : The number of Remote Units depends on the configuration of the Master Unit

figure 6-1 System description

## 6.1 Mechanical installation

**Note:** Due to power dissipation the Repeater may heat up the air volume inside the cabinet and reach a very high temperature. Therefore it is necessary to mount the Repeater in the vertical plane to a wall or a mast without additional enclosure to provide sufficient ventilation. Between the housing and the wall a minimum distance must be kept in order to provide air circulation.

The Repeater must be mounted in the vertical plane to a wall or a mast, which means the connectors have to be located at the bottom.

Use the mounting brackets, which are part of the delivery. This will guarantee a minimum distance between the wall and the Repeater housing. The cabinet must be fixed to the wall (brackets) with four screws.

Check the correspondence of the wall mounting kit and the wall.

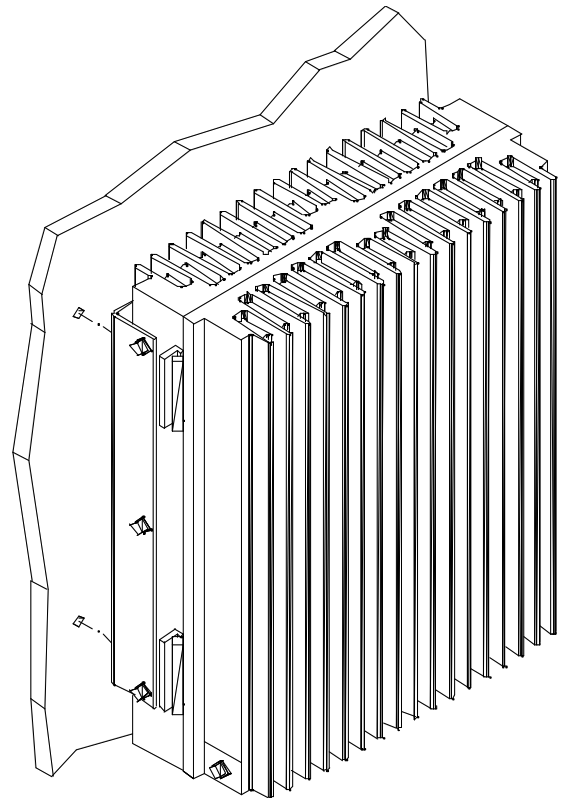

**Note:** The weight of the MOR701B Power is approximately 47 kg in standard configuration.

Mounting procedure:

Dismount the mounting brackets first. They are screwed tight to the housing with four socket head cap screws M8.0x16 (see figure below) and two tire bolts.

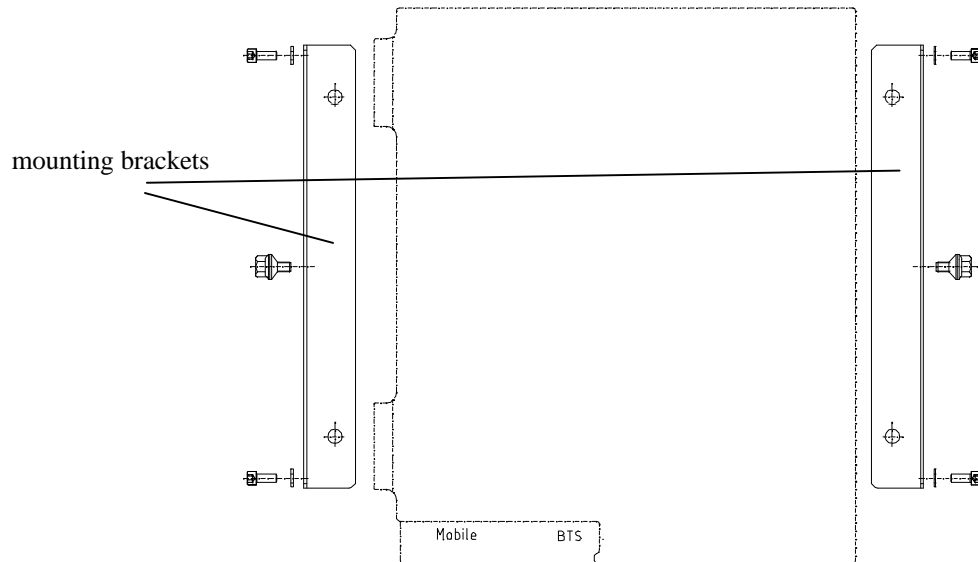

figure 6-2 Wall mounting brackets

Use the wall mounting sheet to mark the position of the drilling holes. Drill 4 holes and screw the mounting brackets to the wall. Attach the upper two socket head cap screws M8.0x16 to the Repeater housing. Now it is possible to hang the Repeater into the mounting brackets. Fix then the lower two socket head cap screws M8.0x16 and the 2 tire bolts.

**Note:** **The unit is heavy-weight. Make sure that a suitable mounting surface is used. Only adequate manpower is allowed to handle the system.**

The installation position of the Repeater follows from the installation drawing, see figure 12-1 Installation drawing of the Repeater. Make sure that there is free access to the electrical connections. The allowed bending radius of the connected cables must not be exceeded.

Furthermore the Repeater shall be mounted in a way that there is free access to the individual units inside the cabinet, while the door of the Repeater is open.

**Therefore keep a clearance distance of 1 m on each side, above and below the unit.**

See following figure 6-3 Clearance distance.

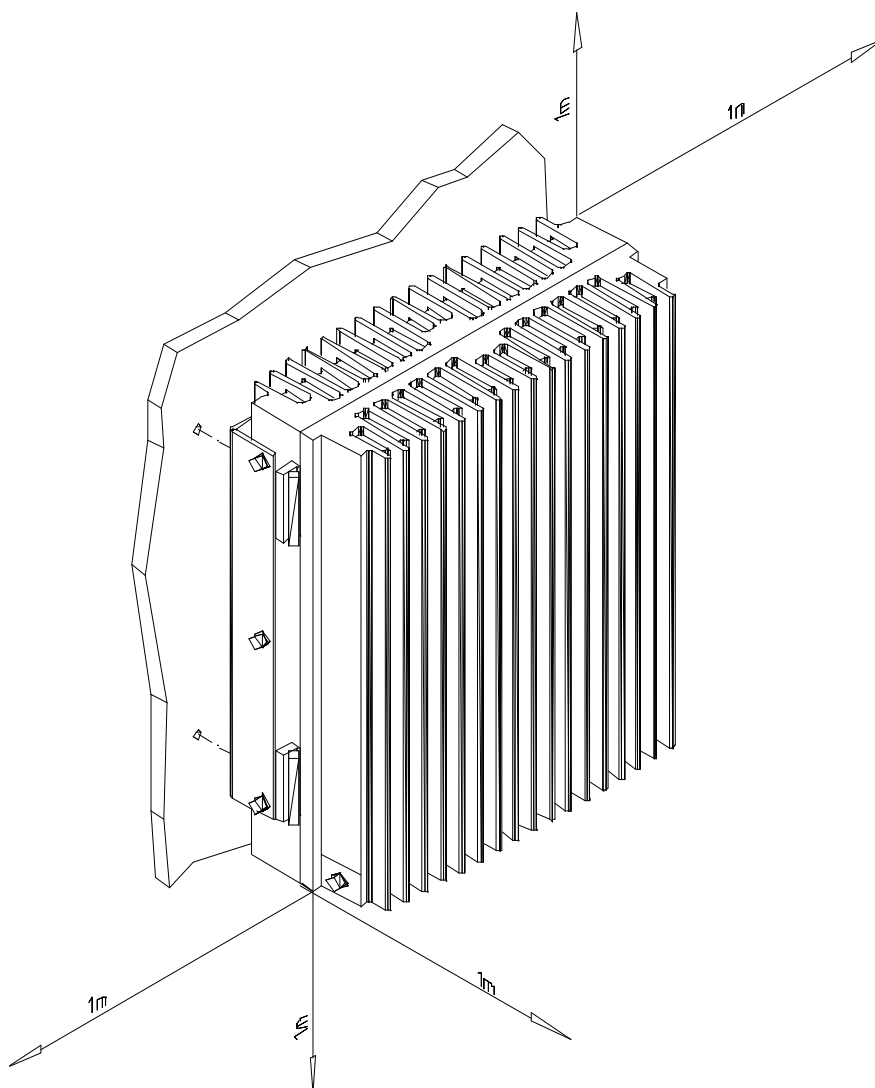

figure 6-3 Clearance distance

## 6.2 Electrical installation

**Note:**

ESD precautions have to be observed! Before working inside the cabinet use the available grounding system to connect ESD protection measures. The electrical installation has to be performed in accordance with the safety regulations of the local authorities. Due to safety reasons the electrical installation must be performed by qualified personnel. The cover of this unit should not be opened while power is applied. Subsequent installation, commissioning and maintenance activities that require the unit to be powered with the cover open shall only be carried out by suitably qualified personnel

### 6.2.1 Grounding

Grounding has to be performed by all means. Therefore a grounding bolt is provided at the cabinet. An earth bonding cable will be mounted in the factory and will be delivered with the unit. Don't use the grounding screw for connecting external devices.

The complete grounding kit is part of the delivery schedule.

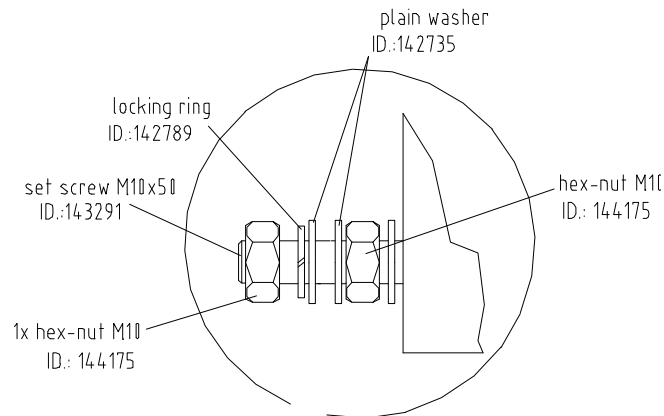

figure 6-4 Grounding kit

### 6.2.2 Power connection

Before connecting electrical power to the Repeater grounding has to be performed. The Repeater is equipped with a firmly connected power cord. Due to safety reasons the power supply lead of the Repeater has to be protected with two 8 A fuses, type MT. In the event the length of the power cord should not be sufficient it can be replaced by a longer cable.

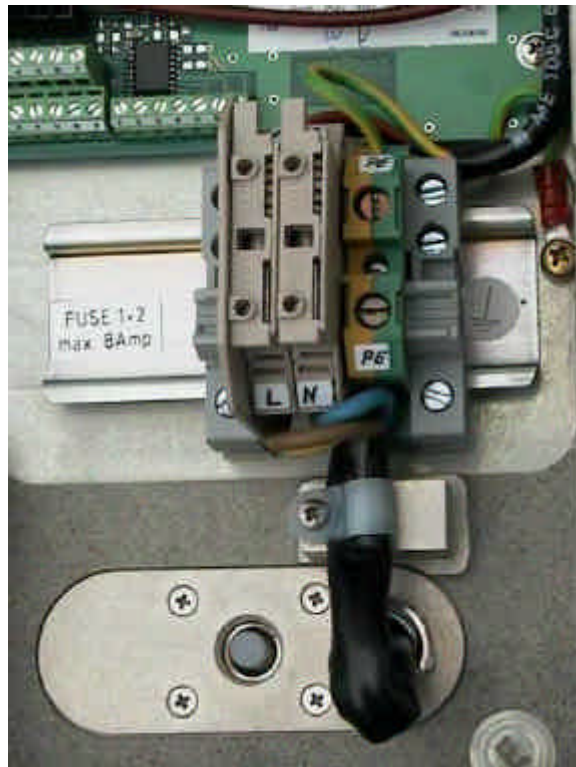

figure 6-5 Screw terminal

**Note:** If the power supply lead has to be replaced use a cable of the same quality.

### 6.2.3 Connection of the antenna cable

The Repeater has a female antenna connector 7/16 (or N with adapter). For mounting the corresponding cable connector we recommend to refer to the applicable documentation of the respective connector manufacturer. The bending radius of the antenna cable must remain within its specification. This will warrant proper operation of the system; otherwise changes in the electrical behaviour of the cable might occur which could cause malfunction of the Repeater system.

**Note:** It is sufficient to fix the 7/16 (or N) antenna connector hand-screwed. Any use of a tool (like tongs) might cause damage to the connector and thus lead to malfunctioning of the Repeater.

## 6.2.4 Connecting fibre optic cables

The standard transmission of the optical signals is carried out by means of an optical fibre pair for each Remote Unit.

**Note:** **Extreme care should be taken when connecting and disconnecting the fibre optic cable. Scratches and dust significantly affect system performance and may permanently damage the connector, necessitating re-termination. Always use protective caps on fibre optic connectors and receptacles when not used.**

The structure of the cable is not critical. However, demands of the site as for example rodent protection and so on have to be kept in mind.

The optical fibre is a single mode fibre. The type is E9/125 with the following minimum requirements.

Attenuation < 0.3 dB/km @ 1300 nm  
Dispersion < 3.5 ps/nm\*km @ 1300 nm

The allowed bending radius of the optical fibres must be kept by all means at any time.

The pig tails for the connection between Master and Remote Unit must have a sufficient length. A protection for the feeding into units has to be given.

The system attenuation of the optical fibres including the connectors must not exceed 10 dB. Less than 5 dB is desired.

The system attenuation and the attenuation of the optical components have to be determined. This can be achieved by measuring the attenuation and the reflection with an appropriate measuring instrument. For pig tails a total value of < 0.4 dB ( measured to a reference plug ) can be assumed due to the dead zone of the reflectometre. These measurements have to be made with a sufficient length of optical fibre in front of and behind the device to be measured.

The fibre cables should be terminated with the same type of connector (DIN 8° or SC/APC 8°) as is used in the unit. The fibre optic cables are connected to the optical Transceiver and receiver.

**Note:** **Angled connectors are not compatible with straight optical connectors; non-compatibility of connectors will result in permanent damage to both waiting connectors.**

Before connecting the fibre cables, follow the procedures below to ensure proper performance. It is important that these procedures be performed with care:

1. Remove fibre optic protective caps.
2. Do not bend the fibre optic cable in a tight radius ( $<4$  cm) as this may cause cable damage and interrupt transmission.
3. Using high-grade alcohol and lint-free cotton cleaning swabs, clean the end of the fibre optic cable that will be inserted in the optical connectors on the donor interface box.
4. Blow the end dry with clean, dry compressed air.
5. Vigorously blow out the laser receptacle with clean, dry compressed air to remove any particulate matter.
6. Connect the fibre optic cables by inserting the cable end into the laser receptacle and aligning the key (on the cable end) with the keyed slot.
7. **Do not** use any index matching gels or fluids of any kind in these connectors. Gels are intended for laboratory use and attract dirt in the field.





## 7 Setting to work

### 7.1 Preparation

**Note:** It is not allowed to operate the Repeater without termination of the antenna connections! The termination can be performed by the antenna connection as well as a dummy load or the 50-Ohm-terminated connection of a measuring instrument.

Before bringing the Repeater system into service it is necessary to measure the antenna isolation. The Repeater system has its maximum available gain when the attenuation is set to zero. On site the maximum allowed gain is 15 dB less than the value of the antenna isolation. In order to check the function of the Repeater system on site it is advisable to operate the Repeater system with 50 Ohm termination. This makes it possible to set the necessary gain and to test the set value without the necessity of transmitting on air.

In order to perform settings the Repeater has to be opened. Please ensure not to damage the seals which are on the modules situated on the RF modules inside of the Repeater, because this would lead to risk the success of warranty claims.

After taking the Repeater into service following signals occur during the boot process.

Internal LED L1		Internal LED L2		Internal LED L3	Cause
green	red	green	red	green	
-	-	-	-		Power on state, Software boot starts
	Flashes red short time		Flashes red short time		Software boot starts
					Software is running

table 7-1 LED indication

## 7.2 Setting of operational parameters

Attenuation of the Repeater can be set manually, locally or remotely. Frequency can be set locally and remotely.

There are three different possibilities to set the operational parameters:

- manual settings by means of rotary switches
- local control via RS232 interface and PC
- remote control via Master Unit

### 7.2.1 Manual setting of the attenuation by means of rotary switches

The manual mode allows the user to set the required attenuation by means of rotary switches. With a small screwdriver, which fits through the long holes of the RF modules, the values can be adjusted by turning the switch carefully to the desired position.

**Note:** To enable manual settings of parameters the mode switch (DIP-Switch 1) has to be changed from OFF to ON.

The DIP-Switch is mounted on the control module, located on the left-hand side of the Repeater.

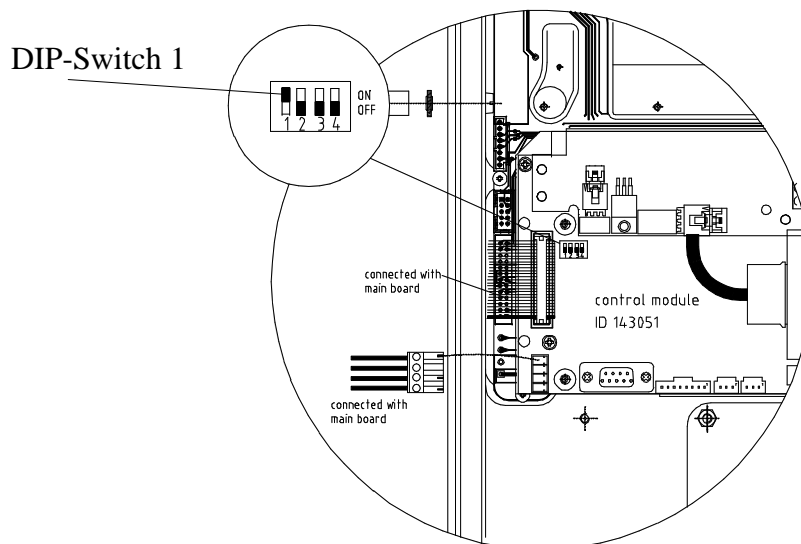

figure 7-2 Position of the DIP-Switch 1

The gain can be set by introducing attenuation into the amplifier chain. By using a rotary switch the attenuation can be adjusted locally in the range from 0 dB to 30 dB maximum in steps of 2 dB. The attenuation can be set for the UL and DL path separately.

The rotary switches are mounted on the mother board. These switches are accessible through the long hole between the two RF modules ( see figure 7-3 Position of the rotary switches). They can be adjusted easily by means of a small screwdriver.

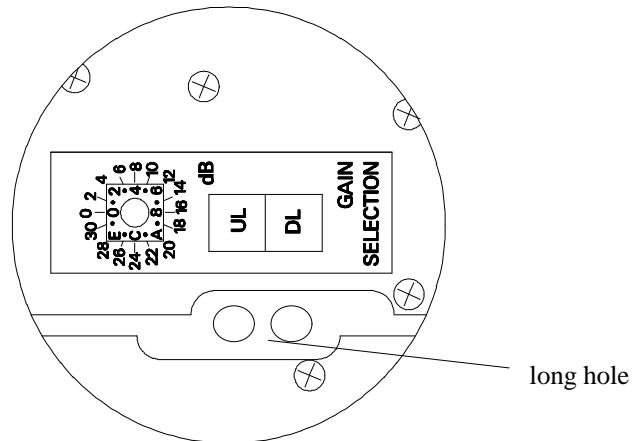

figure 7-3 Position of the rotary switches

A label on the RF module, located next to the rotary switch, illustrates the usage of the rotary switch (see figure 7-4 Rotary switches and label).

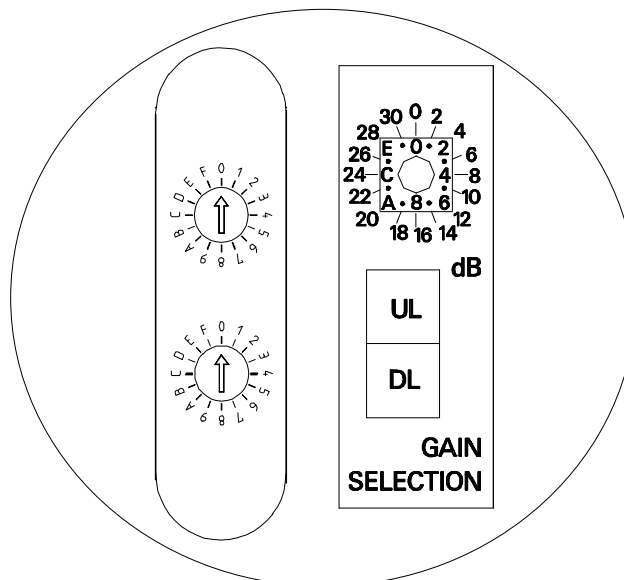

figure 7-4 Rotary switches and label

**Note:** Gain can be changed independently for the uplink and downlink path.

DIP-Switch configuration:

DIP-Switch	ON	OFF (default values)
1	manual	auto
2	remote mode	local mode
3	n.c.	n.c.
4	software download manually controlled	software download controlled by software

table 7-5 DIP-switch configuration

### 7.2.2 Settings via personal computer as terminal

Instead of manually setting operational parameters via rotary switches it is also possible to use the functions of the control module. The local mode for settings via PC has to be set. Therefore the DIP-Switch 2 has to be at position OFF.

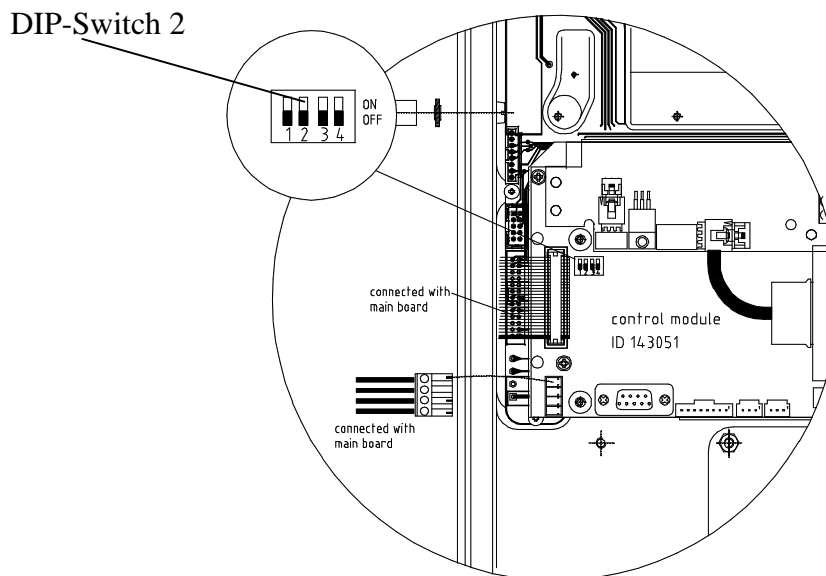
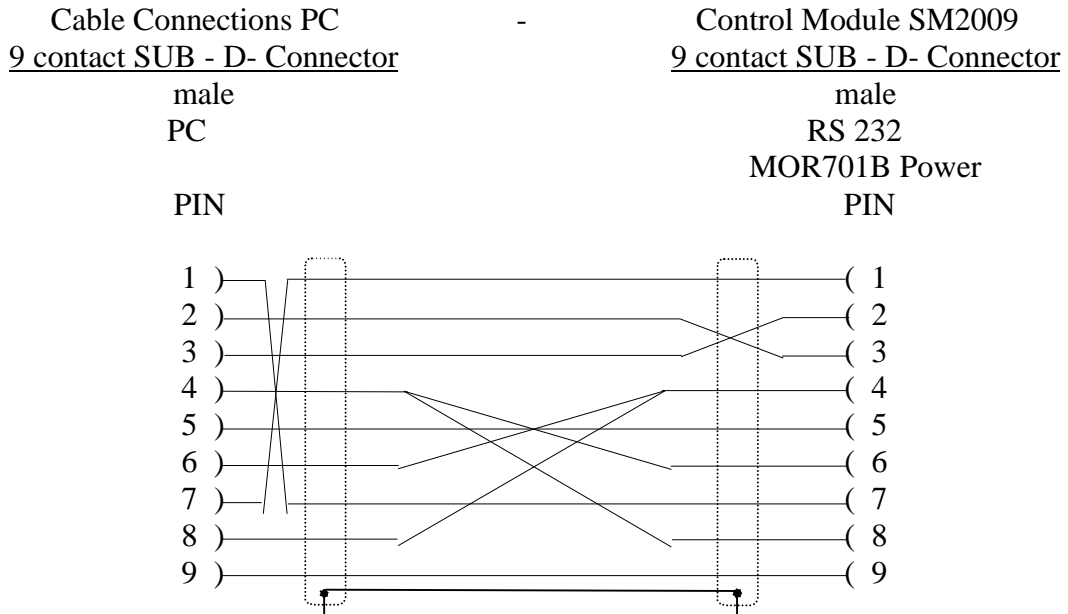

figure 7-6 DIP-switch 2 for local mode

A VT100 terminal or a PC with VT100 emulation can be connected to the control module SM2009 by a standard RS232 cable, if necessary in connection with an adapter 9 to 25.



The following communication mode between control module and VT100 is set initially.

**9600 baud - 8 bit - no parity -1 stopbit**

These settings can only be changed after connection of the terminal.  
 Modifications are possible by software commands.

**Note:** **Settings on the Repeater can be performed after the following procedure only.**

After connecting the PC to the Repeater, following procedure is necessary to get access to the program.

```
MIKOM REPEATER MOR701B - SM2009 - SW: REP1007V1.11  
ENTER <.> <CR> TO LOGIN
```

1. Step: Type the two keys ( . ) FULLSTOP and (↵) ENTER

You have to type the keys:

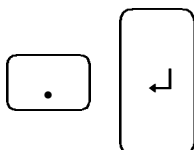

2. Step: ENTER USER ID

You have to enter: **UserID1** ↵

**Note:** The input is case sensitive, no blanks. After three mistrial follows disconnection.

3. Step: ENTER PASSWORD

You have to enter: **P-word1** ↵

**Note:** The input is case sensitive, no blanks. After three mistrials follows disconnection.

### 7.2.3 Remote control via Master Unit

The Remote Unit can be set remotely through the optical interface by devices connected to the Master Unit.

## 8 Trouble shooting

All Repeaters are factory-set to „Power down disabled“ status, this means the channel group is active. To switch off the channel group use the software command „PWRDOWN enabled“. (You find a detailed description in the software manual.)

### 8.1 Error indication

= LED on

- = LED off

Internal LED L1		Internal LED L2		Internal LED L3	Cause
green	red	green	red	green	
-	-	-	-	-	No power. Check presence of power at the input; replace fuse according to chapter 9.3, check battery backup module
					Indicates a summary failure

### 8.2 Boot process

Following signals occur during boot process.

Internal LED L1		Internal LED L2		Internal LED L3	Cause
green	red	green	red	green	
-	-	-	-		Power on state, Software boot starts
	Flashes red short time		Flashes red short time		Software boot starts
					Software is running

### **8.3 Alarm monitoring with the STATUS HIST command**

Check alarms with 'status hist' command.

1. If a hardware module is damaged, replace corresponding hardware module.
2. Minor alarms with no influence on the system can be cancelled by confirming the alarm with the 'alarmackn' command, e.g., ALC active, VSWR, RSSI or DOOR OPEN.
3. If all alarms have been acknowledged the summary error LEDs will be set back to green indication.
4. In case of mains power failure the contents of the actual STATUS HIST list is lost.

For a complete list of available alarms, see table 3-4 List of all available alarms

### **8.4 Power supply**

The output voltage is factory set and should not be changed.

### **8.5 General remarks**

- After a software download previous user settings ( data default values ) might be overwritten. Before you start a software download save the set values for:
  - centre frequency
  - attenuation
  - ALC threshold
- If an ALC or AMPBIAS alarm occurs during installation or commissioning an user error might be the cause, due to wrong measurements.



## 9 Maintenance

### 9.1 General

**Note:** The Repeater does not require preventative maintenance measures.

It is only recommended to replace the RAM/RTC battery after three years usage as a prophylactic measure. The nominal lifetime of these batteries is five years under normal environmental conditions.

In the event of a malfunction it is advantageous to check the status of the antenna systems as well as the continuity of the entire cabling including connectors, before replacing the modules.

Maintenance on the Repeater shall be performed only by replacing modules. Soldering on printed circuit boards shall be avoided. In order to sustain warranty take care not to damage unintentionally the seals on the modules.

The spare part list, consequently, contains only units, which can be replaced without tuning or complex soldering work.

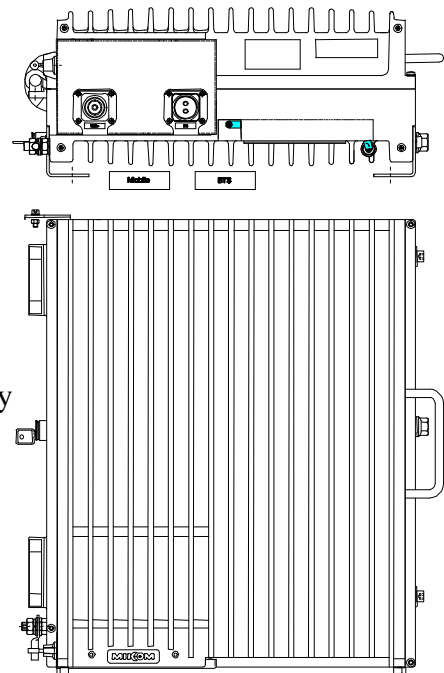

figure 9-1 Top view of the Repeater

**Note:** Defect parts should only be replaced by original parts from MIKOM. All interventions inside the housing are at one's own risk. During maintenance ensure that the Repeater has been disconnected from mains.

Open the lock at the connector panel and remove the cover plate. To open the housing use a Torx key and unscrew the four Torx screws.

### 9.2 Replacement of the fuses (mains)

The mains cable is protected with two fuses F1 and F2 8A type MT. They are accessible inside of the Repeater at the fuse terminal on the right-hand side. Open the screw plug for the fuse and take out the fuse.

**Note:** Use only fuses of the same type and the same rating when replacing!

See figure 9-2 Fuse terminal for position of the 8A fuses.

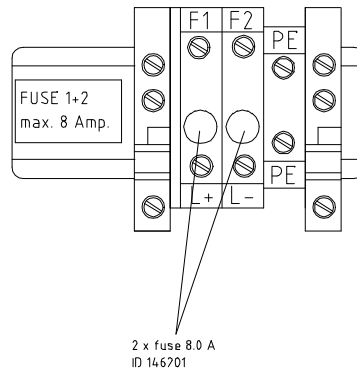

figure 9-2 Fuse terminal

### 9.3 Replacement of the power supply fuse

Each power supply is protected with a fuse 10 A / 35 V. The fuse is mounted outside of the power supply housing.

**Note:** Use only fuses of the same type and the same rating when replacing!

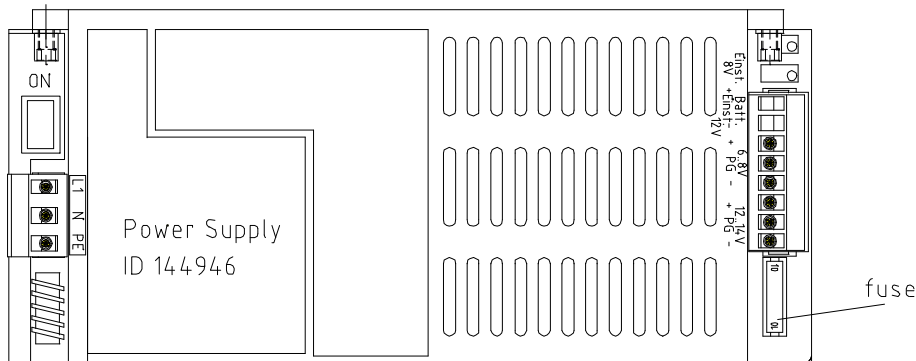

figure 9-3 Position of power supply fuse

### 9.4 Replacement of the mains cable

The Repeater will be delivered with a firmly connected mains cable.

In case the length of the delivered mains cable should not be sufficient or in case of a defect, the mains cable can be replaced.

**Note:** Disconnect Repeater from mains first.

Remove the clamping profile at the outside of the housing by pulling at the mains cable. Open the PG9 threaded joint with a spanner size 17. Inside the housing remove the plastic cable clip by unscrewing the tallow-drop screw. Then use a small screwdriver and open the screws of the fuse terminal.

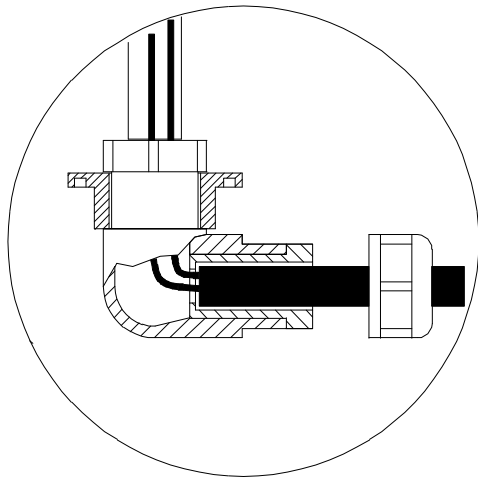

Now the mains cable can be removed by pulling at the cable. For the installation of a new cable strip the isolation of a new cable to the length of 18 cm. Put the screw of the cable gland over the cable then use the joint rubber and **pull it over the cable**. This will guarantee a tight connection. Now insert the cable. Inside the housing pull an insulated tube with the length of 8 cm over the wires. Now close the PG9 threaded joint. Screw the wires to the fuse terminal. Fix the cable with the plastic cable clip.

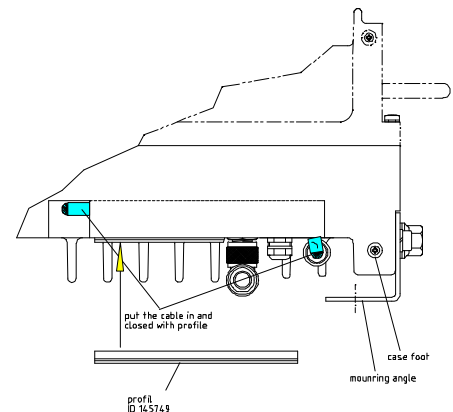

Put the cable in the guide shaft and close it with the clamping profile.

### 9.5 Replacement of the RAM / RTC battery

The RAM / RTC battery of the control module has to be replaced in case of memory loss or as a preventive measure after approximately three years usage. The RAM / RTC battery is mounted on the left-hand side of the Repeater underneath the dummy battery backup module. First remove the whole dummy battery backup module ( see figure 9-5 Position of dummy battery backup module ), which is plugged into the control module. Take off the Lithium battery by means of a small screwdriver, placed between the battery and the battery socket.

The type of the battery is CR 2450 Lithium 3 V / 500mAh, manufacturer is RENATA.

After replacement of the RAM battery, the control module has its basic settings, date and time have to be set to the actual value.

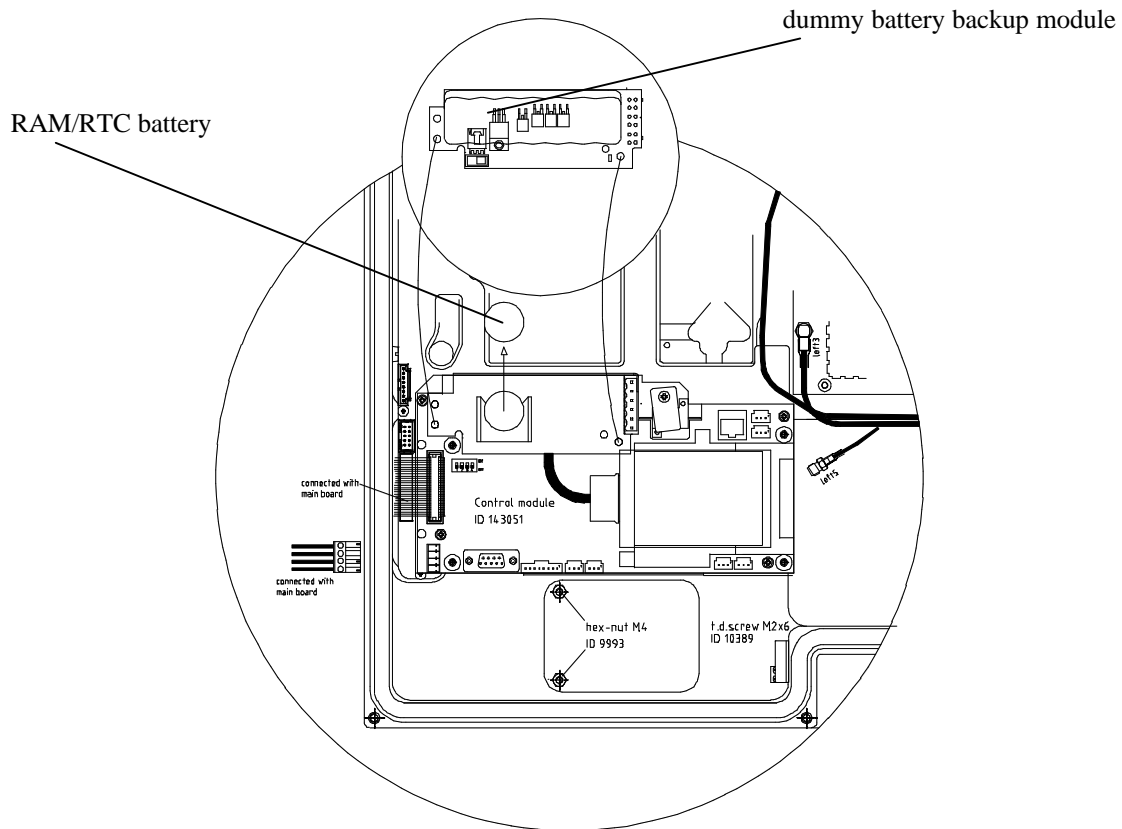

figure 9-4 Position of RAM/RTC battery

**Note:** Before replacing the battery, disconnect the Repeater from mains. Observe the rules for changing Lithium batteries. Wrong connection or treatment may result in bursting of the battery and dissemination of hazardous substances.

Don't try to charge this battery.

### 9.6 Replacement of the dummy battery backup module

The dummy battery backup module is accessible after opening the housing on the left-hand side.

Before you are able to remove the module from the socket, release the three snap-in lockings.

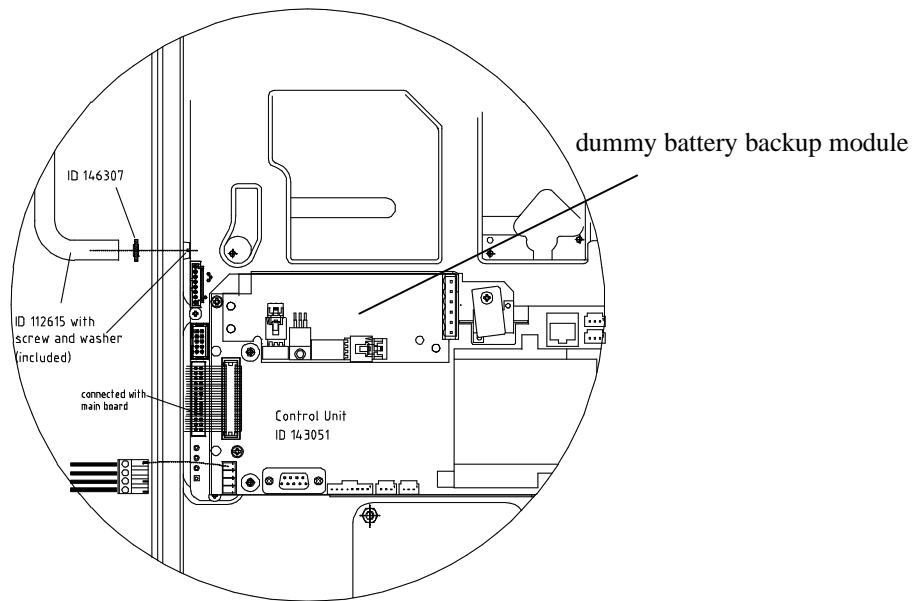

figure 9-5 Position of dummy battery backup module

### 9.7 Replacement of the duplexer

This description is valid for the one channel configuration of the Repeater only. For different configurations refer to the assembly guide for the Repeater.

Remove the semi-rigid cables which connect the DL Output with the feed forward amplifier by loosening the SMA connector. Use a torque wrench. Then remove the semi-rigid cable from the mother board.

It is recommended **not** to remove the amplifier which is mounted on the backside of the duplexer. A new duplexer will be delivered with a premounted amplifier.

The cables have to be connected as shown below.

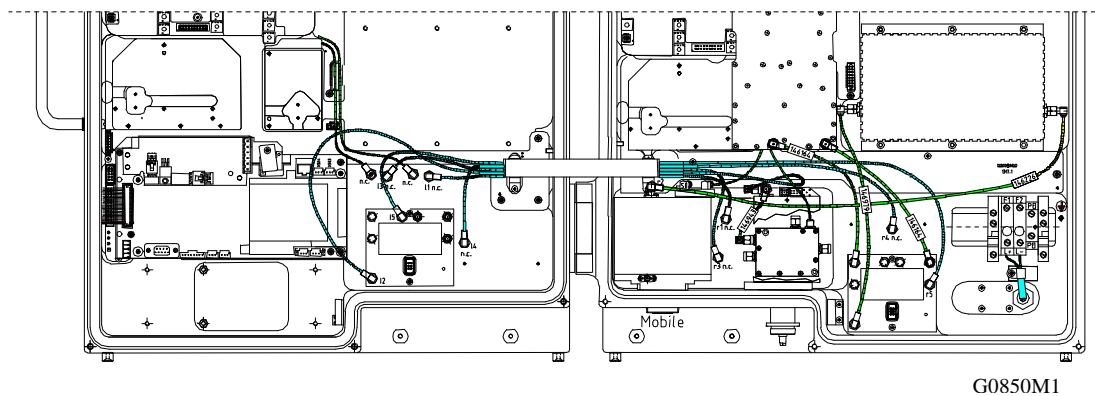

figure 9-6 Cable configuration of the duplexers

Unscrew the four counter sunk screws M3 at the connector panel of the Repeater. See figure 9-7 Connector panel layout.

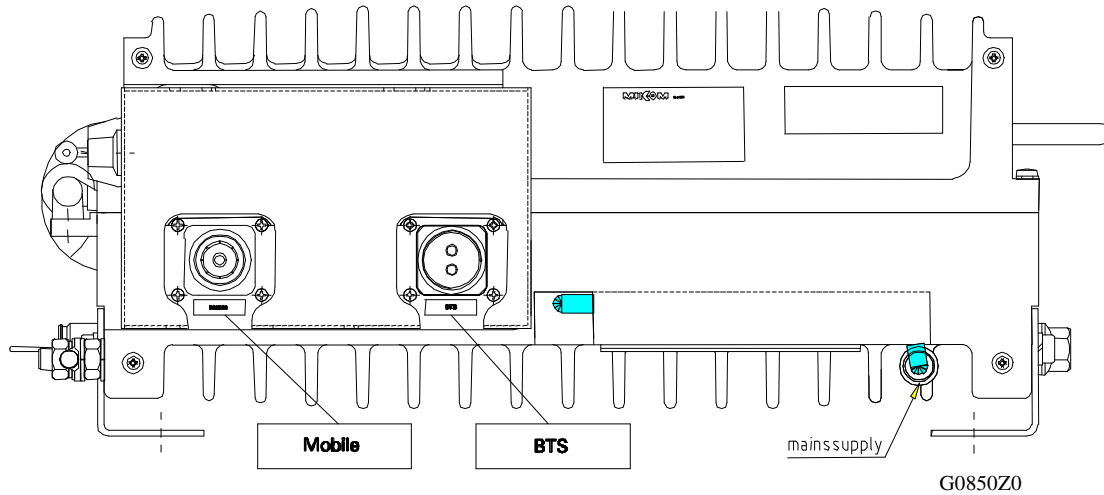

figure 9-7 Connector panel layout

### 9.8 Replacement of RF modules

To remove the RF modules, disconnect the SMA connectors by means of a torque wrench.

If the Repeater is equipped with TDMA modules, the external filter on top of the modules must be dismantled beforehand. The external filter box covers two of the socket head cap screws the TDMA module is fixed with.

Unscrew the socket head cap screw on top of the external filter box, pull the box carefully off and continue the dismantling procedure as described below.

Unscrew six socket head cap screws by means of a hex socket key.

Pull carefully by means of the mounting strap, fixed on the module (see figure 9-8 Top view of an RF module) and take off the module.

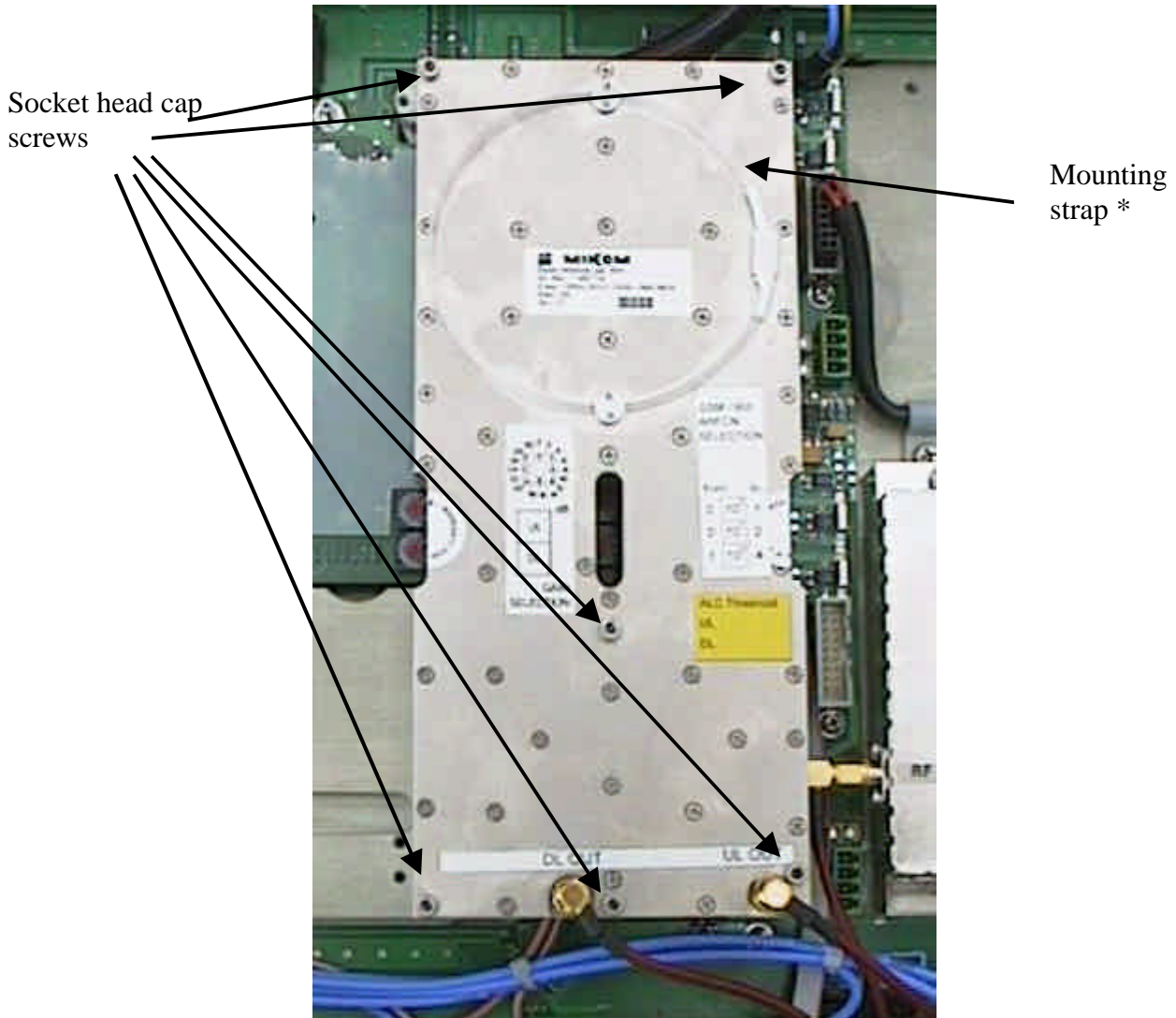

\*: TDMA and CDMA modules are equipped with mounting straps on the left and on the right side.

figure 9-8 Top view of an RF module

Connecting the RF modules depends on the number of channels your Repeater is equipped with, i.e. with one up to four channels. Each configuration has got a different cabling. See assembly guide of the channel modification kits for the cabling of the RF modules dependent on the configuration of the Repeater.

For the exchange of an RF module or the installation of a new RF module, the slave address of the synthesizer has to be set. This can be done by means of hex-coded rotary switches mounted on the lower side of the modules (figure 9-9 Position of hex coded rotary switches).

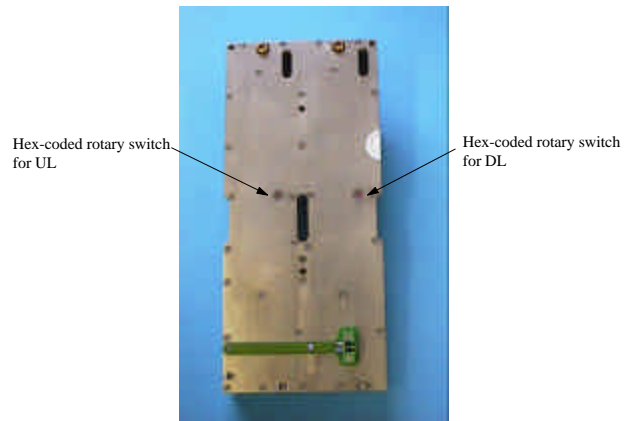

figure 9-9 Position of hex coded rotary switches

The synthesizer address must be set like shown in the following table:

RF module	Address	
	UL	DL
Channel one	0	1
Channel two	2	3
Channel three	4	5
Channel four	6	7

table 9-10 Address of synthesizer

Instructions for band selective modules with variable bandwidth can be found in a separate document.

### 9.9 Replacement of the control module SM 2009

The control module is a Printed Circuit Board situated on the left-hand side of the Repeater.

Disconnect the DC cable from power supply.

Disconnect the flat cable.

Remove the battery backup module and remove the Tyrap which is fixed to the control module.

Take off the whole control module completely with mounting plate by unscrewing four tallow drop screws M4.





The power supply is fixed to the Repeater housing by means of two special nuts M4. After loosening the screws the power supply can be removed. To open these screws a special key with a spherical head is required (This key is part of the delivery). Place a small screwdriver between the Repeater housing and the power supply to loose the device.

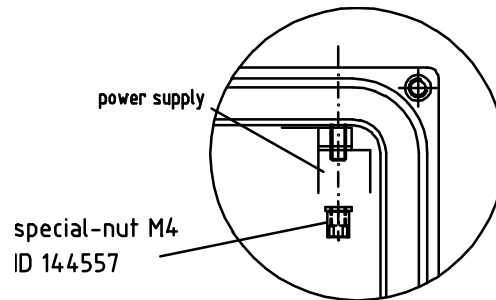

figure 9-13 Position of special-nut M4

**Note:** Don't forget to put heat conducting paste on the mounting side for installation of a new power supply. Use the conducting paste, which is included in the spare parts kit.

### 9.11 Replacement of Active Combiner modules

The Active Combiner modules are mounted on both sides of the Repeater.

Disconnect all SMA connectors by means of a torque wrench.

Unscrew two counter sunk screws M3x20mm. See figure 9-14 Position of counter sunk screws on Active Combiner.

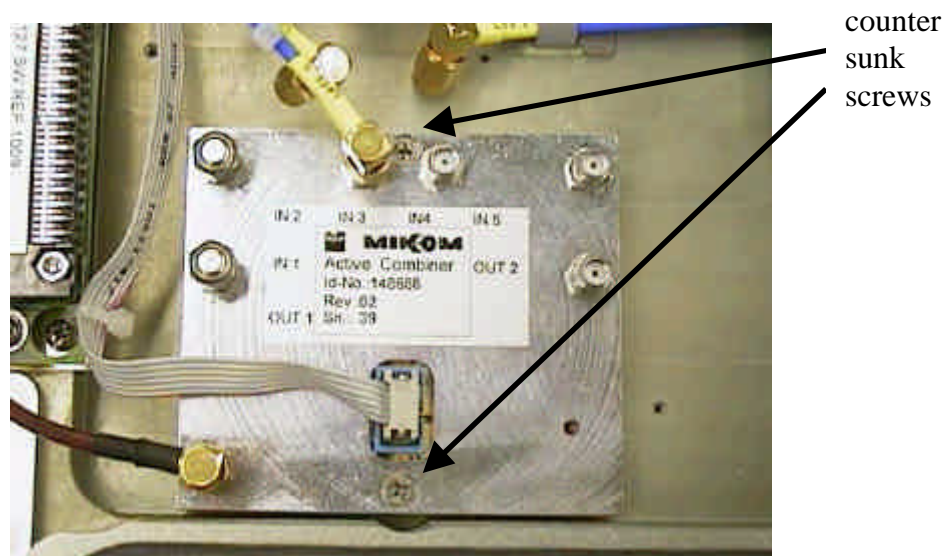

figure 9-14 Position of counter sunk screws on Active Combiner

The cabling of the Active Combiners depends on the configuration of the Repeater. For correct connections see assembly guide for the channel modification kits.

### **9.12 Replacement of feed forward amplifier**

There is one amplifier mounted on the right-hand side of the Repeater. It is fixed to the housing by means of 6 socket head cap screws M4x25.

A special reset board is connected to the 15 pole SUB-D connector. (see figure 9-15 Position of the feed forward amplifier reset board)

This reset board is part of the feed forward amplifier. A new feed forward amplifier will be delivered with a premounted reset board.

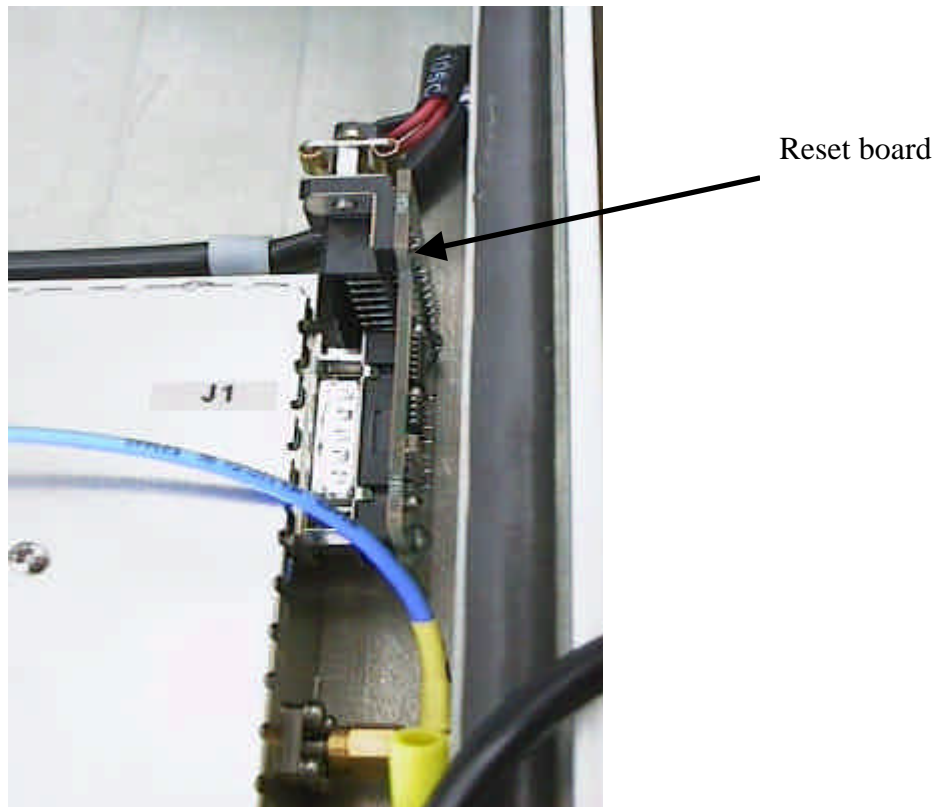

figure 9-15 Position of the feed forward amplifier reset board

Remove the ready made cable which is plugged to the 15 pole SUB-D connector of the reset board. Unscrew the screw clip first.

The SMA connectors can be removed only **after** dismantling the amplifier.

Position of the feed forward amplifier is illustrated in figure 9-16 Position of feed forward amplifier (Right-hand side of Repeater).

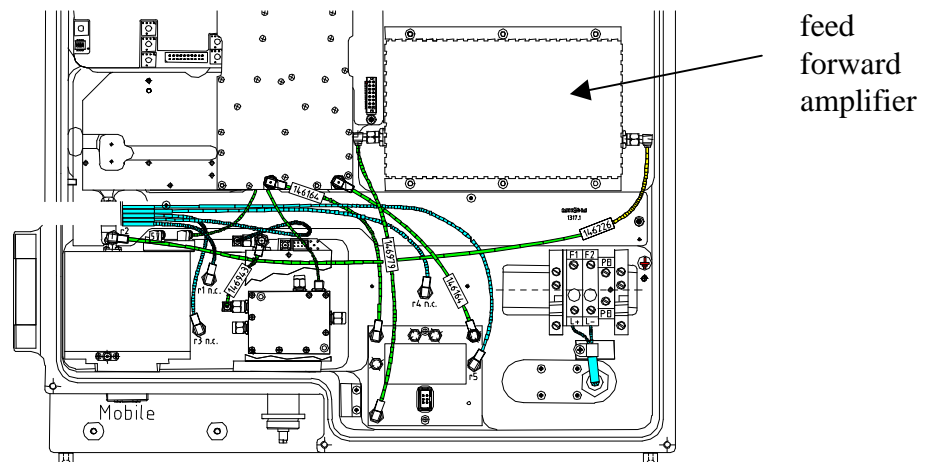

figure 9-16 Position of feed forward amplifier (Right-hand side of Repeater)

### 9.13 Replacement of the FSK modulator

To remove the FSK modulator disconnect all connected cables. Remove the two tallow drop screws which connect the FSK modulator with the MFY1319. The device can be removed.

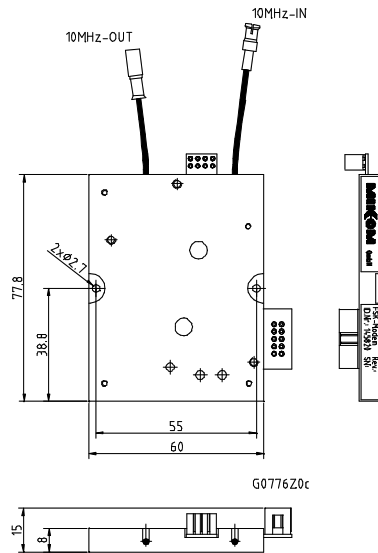

figure 9-17 FSK modulator

### 9.14 Replacement of the Transceiver MFY1319

To remove the Transceiver dismount the FSK modulator which is fixed with two screws M3 on top of the Transceiver. Disconnect all cables. Then unscrew the four counter sunk screws M3 at the connector panel. Now you can remove the Transceiver MFY1319.

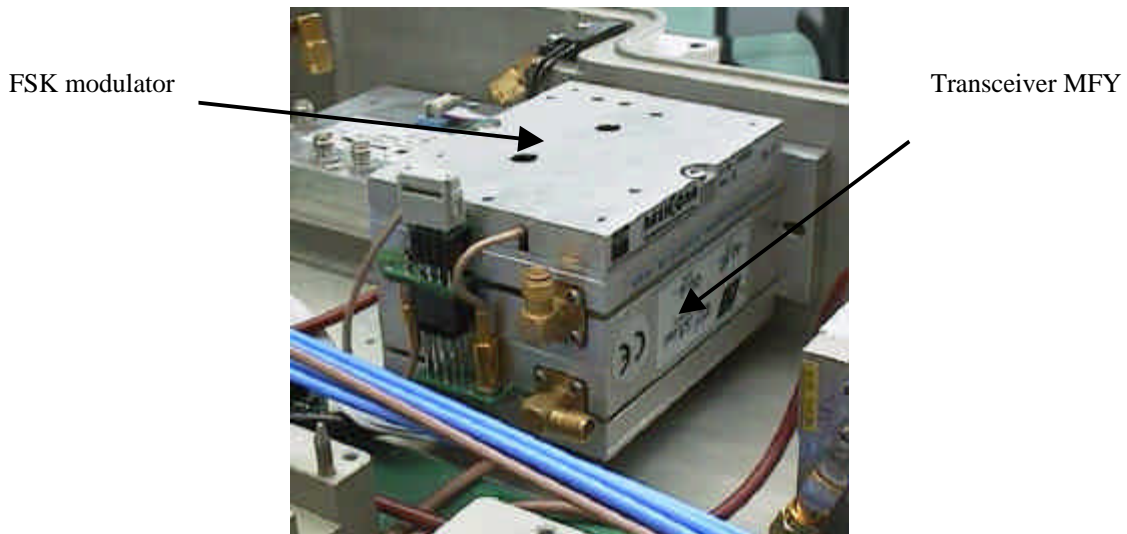

figure 9-18 Installation position

## 10 Spare parts list

The following list contains all parts available for the MOR701B Power . The configuration of the delivered unit meets the requirements of the customer and can differ depending on the state of delivery.

Designation	Id.-No.
Mounting material	150521
Basic Module	148702
Extension Module	148705
Basic Module TDMA	148703
Extension Module TDMA	148706
Basic Module CDMA	148704
Extension Module CDMA	148707
Basic Module var. BW	148714
Extension Module var. BW	148945
Conversion Module 5 MHz	148716
Conversion Module 15 MHz	148717
PCS Duplexer UL Input 1850.0 - 1885.0 MHz	144382
PCS Duplexer UL Input 1875.0 - 1910.0 MHz	144384
Feedforward Amplifier 1930 - 1990 MHz	148628
Transceiver MFY1319 DIN Connector	143094
Transceiver MFY1319 SC Connector	146616
FSK Modulator 10,7 MHz	145820
Power Supply 115 Vac $\pm 15\%$ 40 - 65 Hz USA plug	141230
Power Supply 230 Vac $\pm 15\%$ 14 - 65 Hz Ger plug	138305
Power Supply 230 Vac $\pm 15\%$ 14 - 65 Hz UK plug	142832
Power Supply 230 Vac $\pm 15\%$ 14 - 65 Hz no plug	144306
Power Supply 24Vdc no plug	145504
Power Supply 185 - 320 Vac 40 - 65 Hz no plug	148812
Power Supply $\pm 42$ - $\pm 60$ Vdc no plug	144946
Power Supply $\pm 80$ - $\pm 130$ Vdc no plug	145524
SW MOB100 V1.10	143055
Control Unit SM2009	143051
SW SLV1007 V1.01	146278
SW SLV1009 V1.04	147956
Manual SW SLV1009 V1.xx	148354
Dummy Battery Backup Module	143750
Battery Backup Module	143052
Sparepart Kit	146200
Wall mounting Kit	146179
Main Board 26V version	149778
Main Board 26V version	149777
Active Combiner DL 1930 - 1990 MHz	148685
Active Combiner UL 1850 - 1910 MHz	148887



4-way-Splitter	150730
Termination Resistor	33167
Ready-made cable data	149936
Ready-made cable DC	149928
Ready-made cable data	148576
Ready-made cable DC	149648
Ready-made cable DC female headers 6 contacts	150753
4 External Alarms option Kit	147710
Adapter 7/16 male N female	112425
Mother board	147024
Manual for MOR701B Power	151154
Assembly guide for modification kits	151045
Modification Kit for one channel	149917
Modification Kit for two channels	149918
Modification Kit for three channels	149919
Modification Kit for four channels	149920

table 10-1 Spare parts list

## 11 Configuration list

The actual configuration of the Repeater system has been entered on a separate list at delivery. This configuration list is subject of the delivery schedule providing actual information of part number, Id. number, serial number and revision status of the Repeater. Whenever parts should be replaced the user is kindly asked to update the list.

See sample below:

<b>Remote Unit MOR701B</b>			
<b>Id.-No.: 147362</b>	<b>SN:</b>		
Part name	Id.-No.	Rev	SN
Basic Module	***	***	***
Extension Module	***	***	***
Power Supply			
Duplexer UL input			
Feed Forward amplifier			
Transceiver MFY1319			
FSK Modulator 10.7 MHz			
Control Unit SM2009			
SW SLV100x			
Battery Backup Module			
Mother Board			
SW MOB100			
Connecting Board			
Active Combiner			
<b>Date:</b> _____	<b>QA:</b> _____		

figure 11-1 Sample of a configuration list



## 12 Appendix

### 12.1 Installation drawing of the Repeater

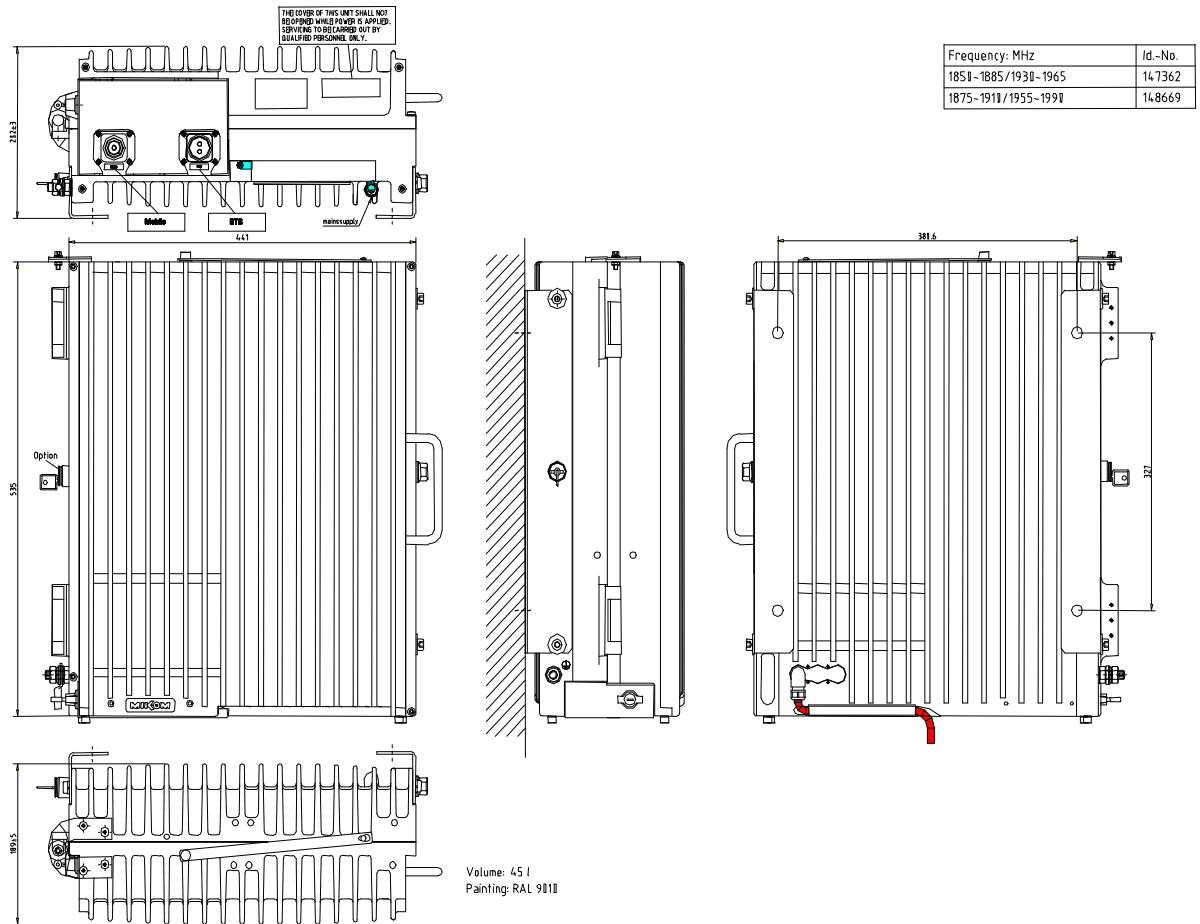

figure 12-1 Installation drawing of the Repeater

### 12.2 Top view of the Repeater (left-hand side , four channel configuration)

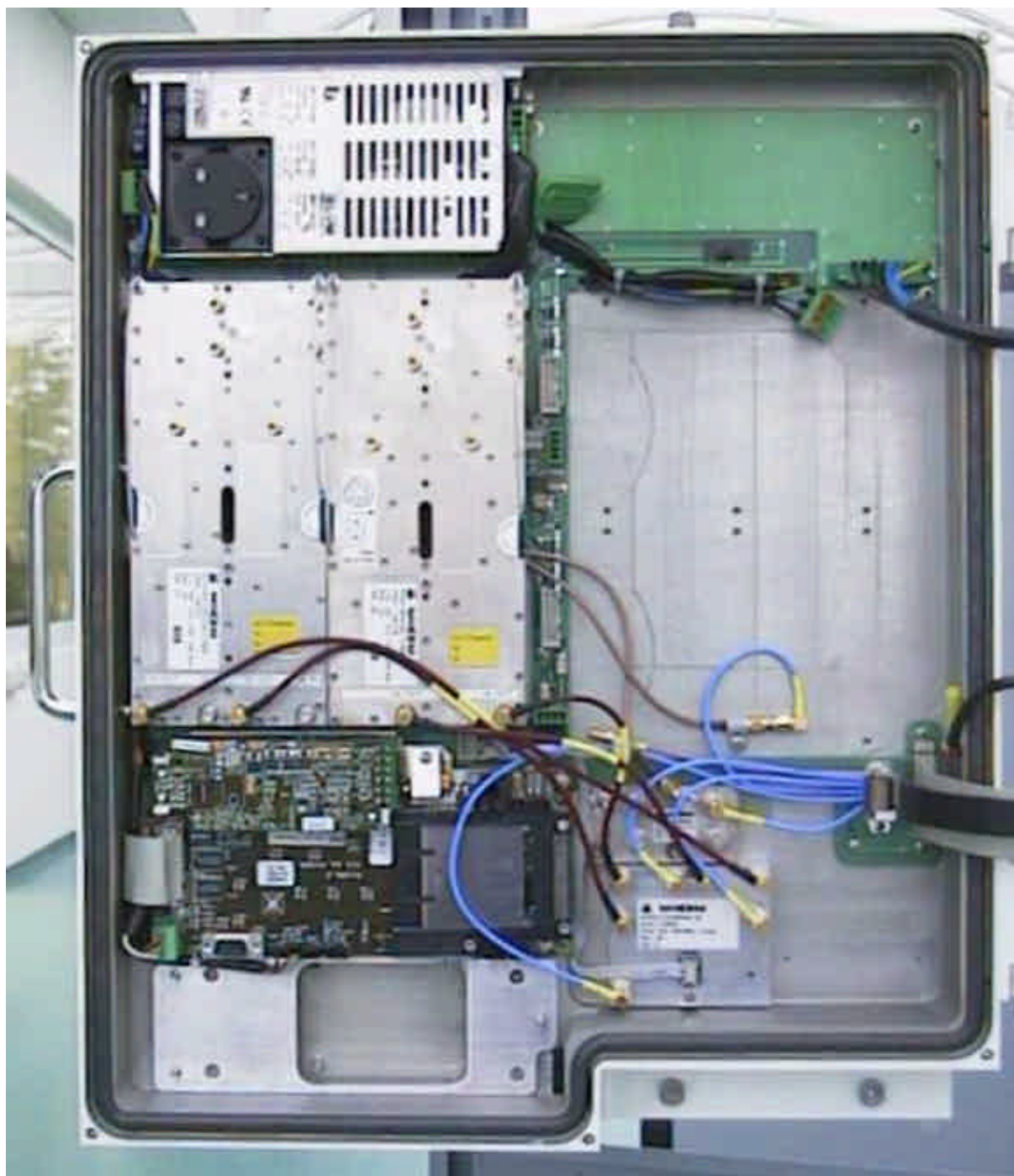

figure 12-2 Top view of the Repeater (left-hand side, four channel configuration)

**12.3 Top view of the Repeater (right-hand side, four channel configuration)**

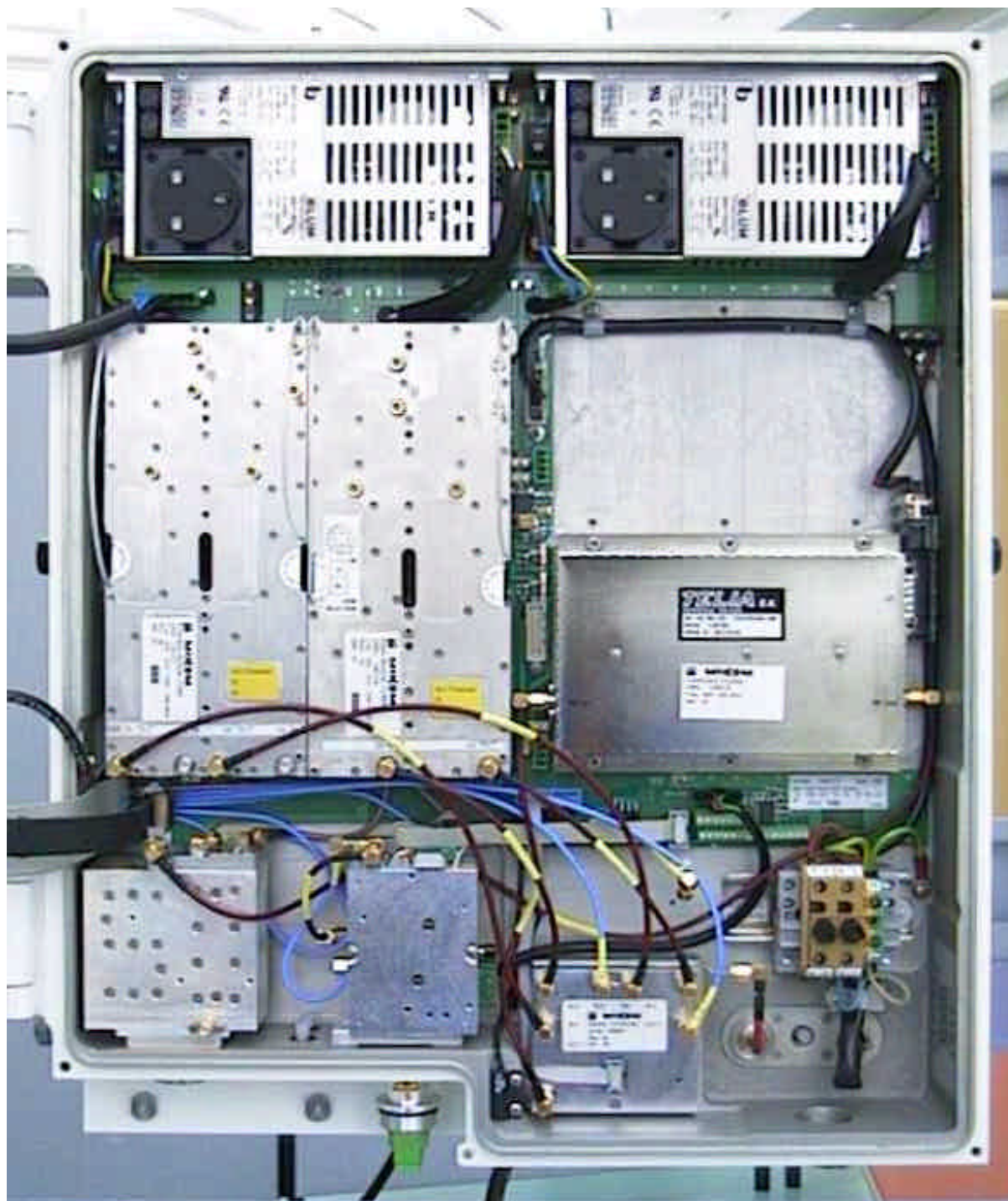

figure 12-3 Top view of the Repeater (right-hand side, four channel configuration)

### 12.4 One channel configuration –block diagram and cabling

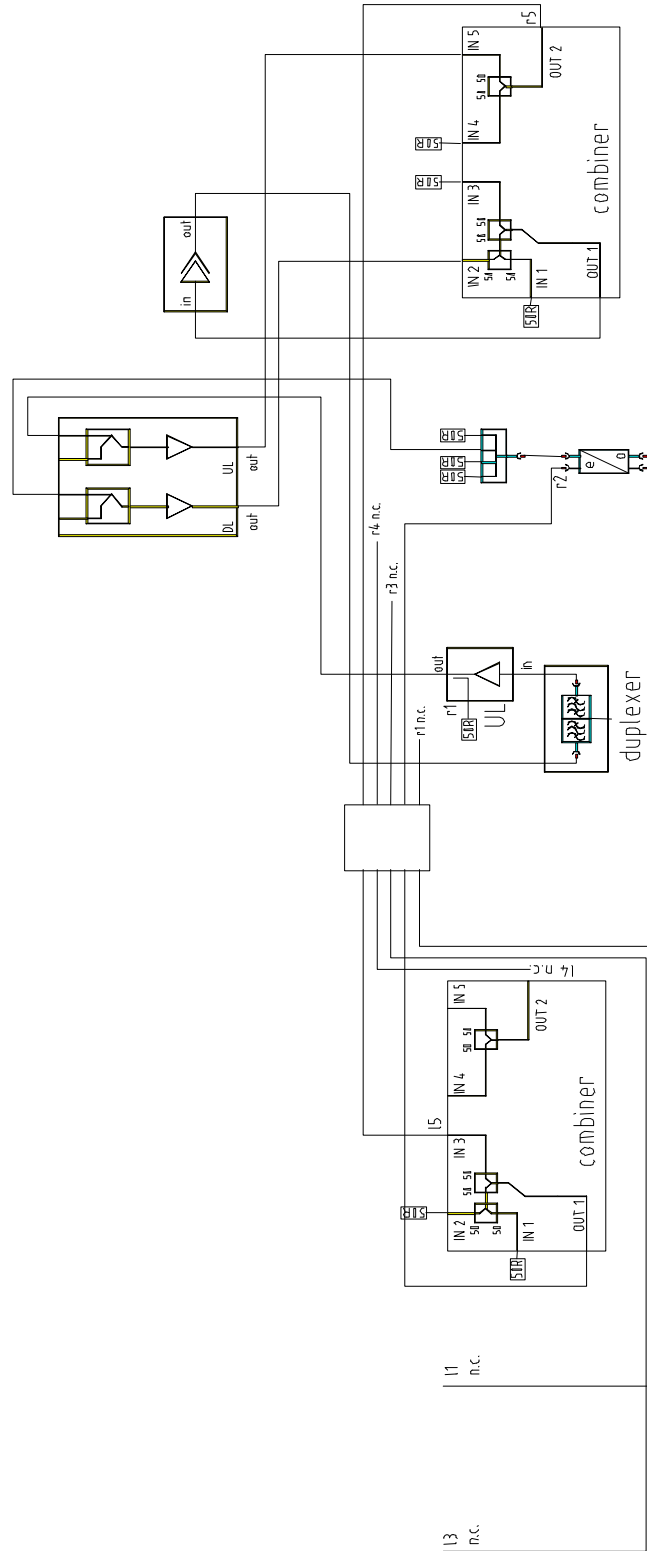

figure 12-4 Block diagram of one channel Repeater

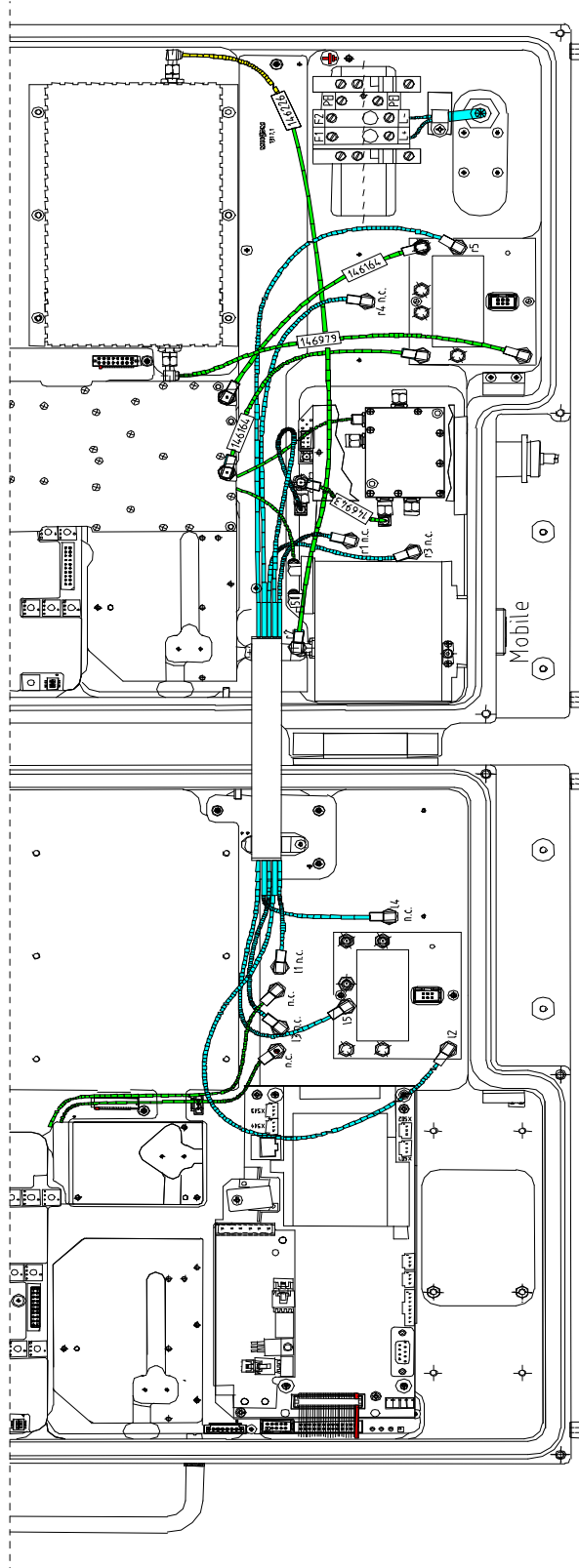

figure 12-5 Cabling of one channel Repeater

## 13 Index

- |   |  |
|---|--|
| <p><b>A</b></p> <p>Abbreviations 8</p> <p>Active Combiner 20, 66</p> <p>Address of MIKOM 11</p> <p>Alarm monitoring 56</p> <p>Alarms</p> <ul style="list-style-type: none"> <li>External alarms 32</li> <li>Handling of 28</li> <li>Indication of 26</li> <li>List of all alarms 28</li> </ul> <p>ALC 26</p> <p>Antenna connector 40</p> <p>Antenna connectors 46</p> <p>Antenna isolation 49</p> <p><b>B</b></p> <p>Battery backup 34</p> <p>BITE 26</p> <p>Boot process 55</p> <p><b>C</b></p> <p>Channel</p> <ul style="list-style-type: none"> <li>Setting via PC 52</li> </ul> <p>Clamping profile 59</p> <p>Connector type</p> <ul style="list-style-type: none"> <li>7/16 female 40</li> </ul> <p>Contents of delivery 9</p> <p>Control module 18</p> <p><b>D</b></p> <p>DIP-Switch 51</p> <p>Dummy battery backup module 60</p> <p>Duplexer 19, 61</p> <p><b>E</b></p> <p>EEPROM 18</p> <p>Environmental and safety 38</p> <p>ESD precautions 11</p> <p><b>F</b></p> <p>Feed forward amplifier 24</p> <p>Fibre optic cable 47</p> <p>FSK modulator 21</p> | <p><b>G</b></p> <p>Gain</p> <ul style="list-style-type: none"> <li>Local settings 25, 51</li> <li>Setting via PC 52</li> </ul> <p>Grounding 45</p> <p><b>H</b></p> <p>Health and safety warnings 10</p> <p><b>I</b></p> <p>I<sup>2</sup>C-Bus 18</p> <p>Ident numbers 70</p> <p>Installation</p> <ul style="list-style-type: none"> <li>Electrical 46</li> <li>Mechanical 42</li> </ul> <p>Interfaces 18</p> <ul style="list-style-type: none"> <li>RS232 18</li> </ul> <p>International sales offices 12</p> <p><b>L</b></p> <p>LEDs 26</p> <p>Local settings 50</p> <p><b>M</b></p> <p>Maintenance 57</p> <p>Measurements of</p> <ul style="list-style-type: none"> <li>VSWR signals 32</li> </ul> <p>MFY1319 20</p> <p>Mother board 17</p> <p>Mounting brackets 43</p> <p><b>O</b></p> <p>Optical connectors 40</p> <p>Optional modules 32</p> <p><b>P</b></p> <p>Power supply 22</p> <ul style="list-style-type: none"> <li>Replacement of 66</li> </ul> |
|---|--|



## R

RAM / RTC battery 59  
Remote control 25  
    via Master Unit 54  
RF module 62  
Rotary switch  
    To set the gain 51

## S

Setting of operational parameters 50  
Setting to work 49  
Severity levels 30  
Specifications  
    Optical 38  
Splitter 22  
Status report 29

## T

Test probe 22  
Transceiver MFY 20  
Trouble shooting 55