

CommScope Era™ Fiber Low Power Carrier Access Point

Installation Guide • M0201ANC_uc • June 2019



DISCLAIMER

This document has been developed by CommScope, and is intended for the use of its customers and customer support personnel. The information in this document is subject to change without notice. While every effort has been made to eliminate errors, CommScope disclaims liability for any difficulties arising from the interpretation of the information contained herein. The information contained herein does not claim to cover all details or variations in equipment, nor to provide for every possible incident to be met in connection with installation, operation, or maintenance. This document describes the performance of the product under the defined operational conditions and does not cover the performance under adverse or disturbed conditions. Should further information be desired, or should particular problems arise which are not covered sufficiently for the purchaser's purposes, contact CommScope.

CommScope reserves the right to change all hardware and software characteristics without notice.

COPYRIGHT

© 2019 CommScope, Inc. All Rights Reserved.

This document is protected by copyright. No part of this document may be reproduced, stored in a retrieval system, or transmitted, in any form or by any means, electronic, mechanical photocopying, recording, or otherwise without the prior written permission of CommScope.

For patents see www.cs-pat.com.

TRADEMARKS

All trademarks identified by ® or ™ are registered trademarks or trademarks, respectively, of CommScope, Inc. Names of other products mentioned herein are used for identification purposes only and may be trademarks and/or registered trademarks of their respective companies.

Andrew Wireless Systems GmbH, 17-June-2019

TABLE OF CONTENTS

Document Overview	1
Document Revision History	1
Document Cautions and Notes	2
Abbreviations Used in this Guide	3
CommScope Part Numbers	3
Era System Overview	4
Fiber CAP L Overview	5
Connectors and LED for the Fiber CAP L	6
CAP L Accessories and Options	7
Fan Kit	7
Mounting and Power Kits	8
OCTIS Kits	9
SFP+ Modules	9
Plan and Prepare for a Fiber CAP L Installation	10
Maximum Number of Fiber CAP Ls Supported in an Era System	10
Cascade Rules for Fiber CAP Ls	11
Cat6A Cable Requirements for Ethernet Devices	12
Safely Working with Era Hardware	12
Health and Safety Precautions	12
Property Damage Warnings	13
General Installation Safety Requirements	13
Guard Against Damage from Electro-Static Discharge	13
Compliance	14
Equipment Symbols Used / Compliance	16
Required Antenna Distances	16
Determine the Power Consumption of the CAP L	17
Determine the CAP L Installation Site	17
CAP L Dimensions	18
Mounting Dimensions for a CAP L with the Flat Mounting Bracket Kit	18
Mounting Dimensions for Two CAP Ls Mounted with the Dual Mounting Kit	19
Mounting Dimensions for a CAP L Mounted with the CAP L Hybrid Fiber Splice Box Kit	20
Mounting Dimensions for a CAP L Mounted with the AC/DC Power Supply Kit	21
CAP L Weights	21
Extended CAP L Temperature Operation	22
Recommended Tools and Material	23
Unpack and Inspect the CAP L and Optional Accessories	23
Obtain the Required Materials	23
Mount the Fiber CAP L	24
General Mounting Cautions	24
Mounting a CAP L with a Flat Mounting Bracket Kit	25
Attach the Flat Mounting Bracket Kit to the CAP L	26
Flat-Surface Mount a CAP L	27
Wall Mount a CAP L	29
Mounting Orientation for Wall Mounts	29
Wall Mount a CAP L Using a Flat Mounting Bracket Kit	30
Mounting Two CAP Ls with a Dual Mounting Kit	31
Mounting a CAP L with an AC/DC Power Supply Kit	38
Wiring the AC/DC Power Supply Kit	38
Mounting a CAP L with a Hybrid Fiber Splice Box Kit	43
Prepare for CAP L Hybrid Fiber Splice Box Kit Installation	43
Assembling and Wiring the Hybrid Fiber Splice Box	43
Wire the Hybrid Fiber Splice Box	44
Wire a Hybrid Fiber Splice Box for 4-Wire Power with Limited Power Source	47
Wire a Hybrid Fiber Splice Box for 2-Wire Power without Limited Power Source	49
Wire a Hybrid Fiber Splice Box to Cascade Two CAP Ls with the 2-Wire Power Configuration	50
Wire a Hybrid Fiber Splice Box to Cascade Two CAP Ls with the 4-Wire Power Configuration	51
Wall Mount a CAP L Using a CAP L Hybrid Fiber Splice Box Kit	52
Ceiling Mount a CAP L	54
Ceiling Mount a CAP L without a Fan Kit	54
Ceiling Mount a CAP L with a Fan Kit	54

Connect the Cables to the Fiber CAP L	55
Ground the Fiber CAP L (Optional)	55
Connect the Fiber CAP L to a Passive RF Antenna	56
Clean the RF Cable Connectors	57
Connect the Passive RF Antenna.....	59
Connect the Fiber CAP L to a Classic CAN or TEN	60
Cascade a Secondary Fiber CAP L (Optional)	61
Connect an External Ethernet Device (Optional).....	62
Connect to Vdc Power	62
Powering on a Fiber CAP L	62
CAP L Maintenance	63
Remove a CAP L from a Wall or Ceiling Mount	63
Preventative CAP L Maintenance for CAP Ls with the Fan Kit Option	63
Contacting CommScope	64
CMS Global Technical Support	64
Telephone Helplines.....	64
Online Support	64
Waste Electrical and Electronic Equipment Recycling.....	64
Hardware to Software Mapping Information	65
Mobility Solutions Technical Training.....	65
Accessing Era/ION-E Series User Documentation	66

DOCUMENT OVERVIEW

There are two variants available for Low Power Carrier Access Points (CAP L): one variant has an optical fiber interface (Fiber CAP L), and the other has a copper interface (Copper CAP L). This installation guide provides a product overview and installation instructions for the Fiber CAP L. (For information on the Copper CAP L, refer to the *CommScope Era™ Copper Low Power Carrier Access Point Installation Guide*; see ["Accessing Era/ION-E Series User Documentation"](#) on page 66). Table 1 lists the CAP L models that this installation guide supports.

Table 1. Supported CAP L Models

Part Number ¹	Model Name
7770203-000x	CAP L 17E/17E/23/23
7770209-000x	CAP L 18/21/26/26
7770356-000x	CAP L 17E/17E/19/19
7776595-000x	CAP L 9/18/18/21
7776596-000x	CAP L 7/80-85/17E/19
7776597-000x	CAP L 17E/19/23/25TDD
7776598-000x	CAP L 9/18/21/26
7776641-000x	CAP L 8/9/18/21
7776643-000x	CAP L 8/18/21/26

¹ The "-000x" suffix provides information as to whether the CAP L has a Fiber or Copper interface, and the power and Fan Kit options. Contact your local sales representative for further information.



For information on how to find the minimum software requirements for Era hardware, refer to ["Hardware to Software Mapping Information"](#) on page 65.

Document Revision History

This is the third release of the *CommScope Era™ Fiber Low Power Carrier Access Point Installation Guide*.

Document Cautions and Notes

This document may contain any of the following notes, cautions, and warning icons.



The icon to the left is used to indicate a caution or warning. Cautions and warnings indicate operations or steps that could cause personal injury, induce a safety problem in a managed device, destroy or corrupt information, or interrupt or stop services.



The icon to the left indicates a caution or warning that pertains to laser equipment.



The icon to the left indicates a caution or warning that pertains to Radio Frequency (RF).



The icon to the left indicates that the hardware is susceptible to Electro-Static Discharge (ESD) damage.



The icon to the left indicates a caution or warning that pertains to an electrical hazard.



The icon to the left indicates a Note. Notes provide information about special circumstances.

Abbreviations Used in this Guide

AP	Access Point	ISDE	Innovation, Sciences et Développement économique Canada
AUX	Auxiliary	ISED	Innovation, Science and Economic Development Canada
C	Celsius	kg	Kilogram
CAN	Central Area Node	LED	Light Emitting Diode
CAP L	Low Power Carrier Access Point	LPS	Limited Power Source
CAP M	Medium Power Carrier Access Point	MHz	Megahertz
Cat	Category	mm	Millimeter
CAT	Copper Transport	MMF	Multi-Mode Fiber
dB	Decibel	N/A	Not Applicable
dBm	Decibel-milliwatts	OPT	Optical Transport
DC	Direct Current	PN	Part Number
DCCS	Distributed Coverage and Capacity Solutions	RAN	Regional-Area Network
EFTA	European Free Trade Association	RF	Radio Frequency
EMC	Electromagnetic Compatibility	RU	Rack Unit
EMEA	Europe, Middle East, Africa	SFP	Small Form-Factor Pluggable
EU	European Union	SMF	Single-Mode Fiber
F	Fahrenheit	TEN	Transport Expansion Node
FCC	Federal Communications Commission	UAP	Universal Access Point
Gb	Gigabyte	Vdc	Volts, direct current
GHz	Gigahertz	W	Watts
ION	Intelligent Optical Network		

CommScope Part Numbers

The CommScope part numbers in this installation guide are in the format of *nnnnnnn-xx*, where the “-xx” suffix indicates the latest release. Contact your local CommScope sales representative for the current release part number.

ERA SYSTEM OVERVIEW

CommScope Era™ coordinates wireless capacity throughout the entire coverage area via a single centralized head-end location or from an operator's existing C-RAN hub. Based on ION-E®, Era operates on the same cost-efficient standard IT cabling as ION-E and is compatible with ION-E deployments. Era systems bring together licensed wireless and power, plus Gigabit Ethernet for WiFi into one wireless system that can scale to building size and is technology and spectrum agnostic and adaptive. An Era system comprises the components listed below.

- **Central Area Node (CAN)**—provides server-level control and primary signal distribution. It combines the signals from multiple operators and distributes those signals within a venue or multiple venues. There are two configuration modes available for the CAN: **Classic** and **Switching**.
 - The **Classic CAN** configuration is appropriate for when all the BTS and Baseband sources are located in a centralized space in the same venue as the Classic CAN. You install RF Donor (RFD) Cards and CPRI Digital Donor (CDD) Cards in a Classic CAN, which digitizes the analog BTS signals from the RFD Cards and combines those with the BBU CPRI digital signals from the CDD Cards, and then distributes the RF signals to the TENS. The TENS then provide the RF signals to the Access Points (APs). The Classic CAN also supports APs that are directly connected to CAT or OPT Cards installed in the Classic CAN chassis. Wide-area Integration Nodes (WINs) are not supported by a Classic CAN. Users have full and flexible control of all signal routing via the Era GUI.
 - The **Switching CAN** configuration is appropriate for when WINs are required to allow operators to bring in baseband signals from multiple remote locations to fully leverage the C-RAN architecture in their hubs. All operator Baseband signals (analog BTS and BBU CPRI) are supplied to the Switching CAN by the WINs, so no RFD or CDD Cards can be installed in the Switching CAN. The Switching CAN then combines the signals from all WINs and distributes those signals to the TENS, and the TENS provide the signals to the APs. APs are not directly connected to a Switching CAN. Users have full and flexible control of all signal routing via the Era GUI.



This guide uses “CAN” to collectively refer to Central Area Nodes. When information pertains to a specific CAN mode, “Classic CAN” and “Switching CAN” will be used.

- **Wide-Area Integration Node (WIN)**—interfaces between a Switching CAN and RF sources, which makes C-RAN possible in Era by allowing operators to bring in signals from multiple remote locations kilometers away. You install RFD and CDD Cards in the WIN, which takes the analog BTS signals from the RFD Cards and combines those with the BBU CPRI digital signals from the CDD Cards, and distributes the RF sources to a Switching CAN.
- **Transport Expansion Node (TEN)**—is an expansion node connected to the CAN via fiber and can be located throughout the venue coverage area. A single TEN can support, dependent on the AP type and powering method, 12 to 32 Access Points (APs), which greatly reduces the number of fiber runs between the head-end and each AP.
- **Access Point (AP)**—connects a Classic CAN or TEN to antennas or other wireless devices. On the downlink, an AP converts data arriving at the AP to analog signals and sends them to an antenna. On the uplink, received signals are digitized and serialized into data streams which are sent back to the Classic CAN or TEN. APs provide pass-through support for WiFi, IP cameras, or other devices over a common cable. An AP can be any of the Universal Access Points or Carrier Access Points.



This guide uses “Access Point (AP)” to collectively refer to all versions of the Universal Access Point (UAP) and the Carrier Access Point (CAP). “Fiber APs” collectively refers to the CAP H, CAP M, and the Fiber CAP L. When information pertains to a specific AP type, that AP will be identified.

FIBER CAP L OVERVIEW

There is one Optical Fiber and two Copper CAP L interface variants. This installation guide describes the Fiber CAP L, which interfaces with a Classic CAN or TEN via an optical link. This allows the Fiber CAP L to provide data over Single-Mode Fiber (SMF) or Multi-Mode Fiber (MMF). Power for Fiber CAP Ls is provided over External AC/DC or remotely through hybrid fiber.

On the downlink, the Fiber CAP L converts data arriving at the CAP L to analog signals and sends them to the Antenna ports. On the uplink, received signals are digitized and serialized into data streams, which are sent back to the Classic CAN or TEN. [Figure 1](#) shows how a Fiber CAP L can be deployed in an Era system.

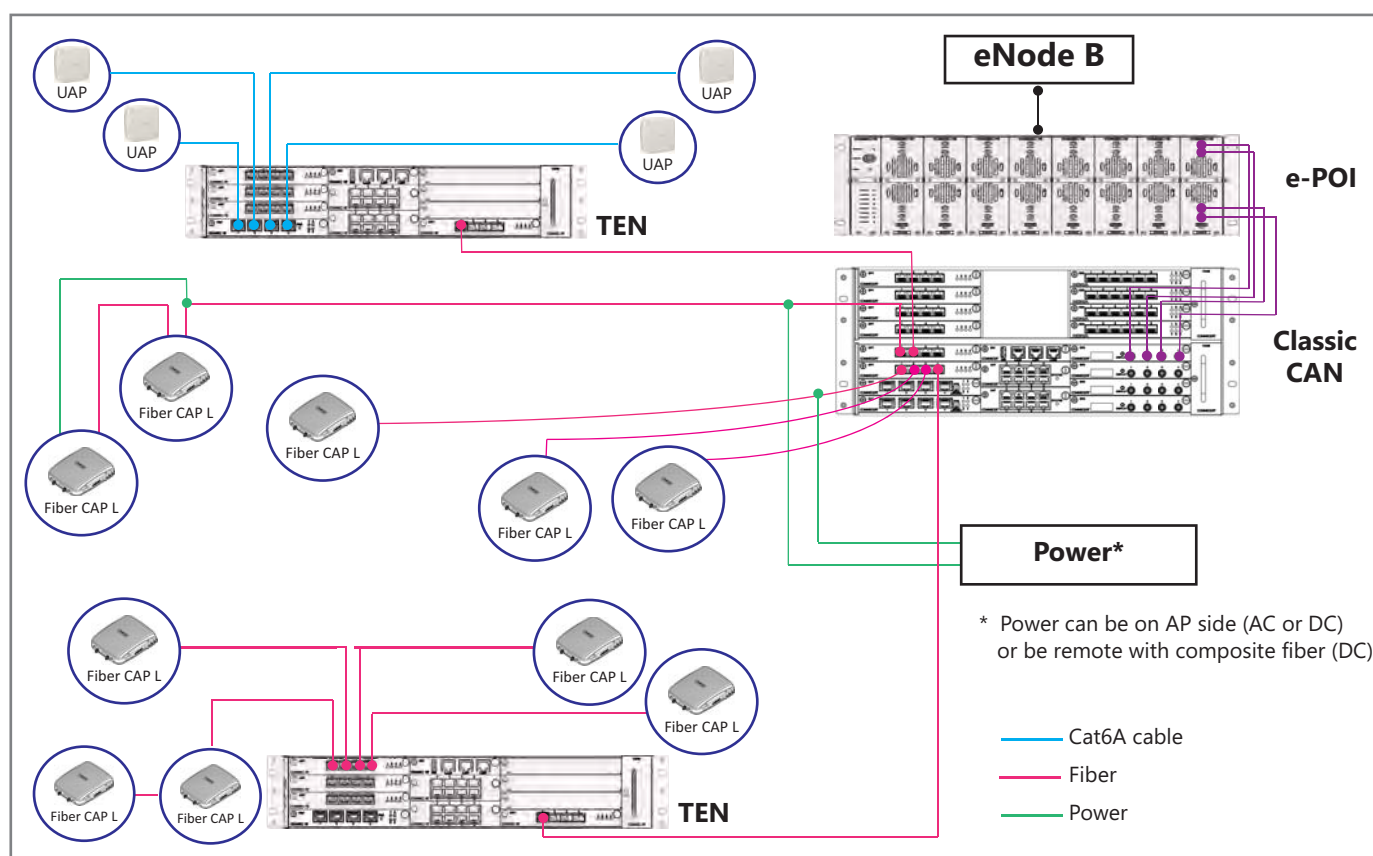

The Fiber CAP L

- has the following temperature ranges
 - without a Fan Kit, it is passively cooled with a temperature range of: -33°C to $+40^{\circ}\text{C}$ (-27.4°F to 104°F); see also ["Extended CAP L Temperature Operation"](#) on page 22.
 - with a Fan Kit, the Fiber CAP L has an increased maximum operating temperature of 55°C (131°F); see also ["Fan Kit"](#) on page 7.
- is outdoor rated (IP67)
- has a typical power consumption that dependent on the model ranges from 92 to 103W; see ["Required Antenna Distances"](#) on page 16.

Connectors and LED for the Fiber CAP L

Figure 2 and Table 2 identify the Fiber CAP L connectors and its LED; corresponding connectors are shown.

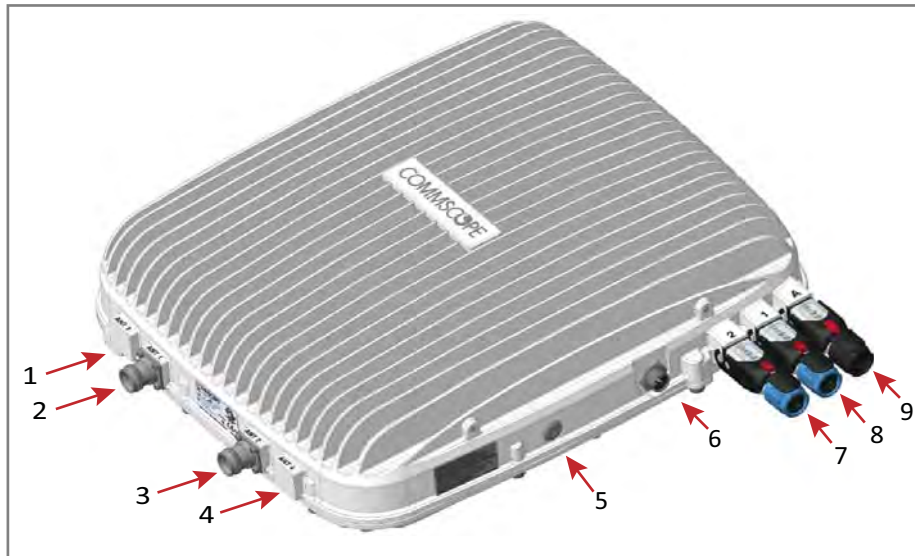

Figure 2. CAP L Connectors and LED

Table 2. Function of the CAP L Connectors and LED

REF #	Label	Description	Function
1, 4	ANT 3, ANT 4	Not available; connector is plugged.	
2	ANT 1	4.3-10 RF connector	Connect to two separate external antennas or to two ports on a cross-polarized dual antenna via 50Ω coaxial cable. Each connector supports two RF bands. The end of the 50Ω coaxial cable that connects to an ANT connector can be either a push-pull or a threaded connector. The ANT 1 and ANT 2 ports ship with dust caps that can be discarded upon unit installation.
3	ANT 2		
5	Power LED (Unlabeled)	Power LED	See "Powering on a Fiber CAP L" on page 62.
6	Unlabeled	Proprietary 4-pin 36 to 60 Vdc Power connector	Connects to a DC power supply, or to a Hybrid Fiber Junction Box; all four pins must be terminated. The CAP L does not ship with any power cables preinstalled; you need to order the power cable assembly that is appropriate for this installation: <ul style="list-style-type: none"> • 7774061-xx: Cable Assembly, CAP L Local Power Jumper, 0.5m • 7816237-xx: Cable Assembly, CAP L Local Power Jumper, 3m
7	2	Optical Port 2	If the CAP L is functioning as a Primary CAP L in a cascade, Optical Port 2 connects to Optical Port 1 of the Secondary CAP L via the Optical OCTIS Kit (PN 7770612), which ships with the unit, to provide the main signal interface. Optical transport occurs over Single Mode Fiber (SMF) or Multi Mode Fiber (MMF). Port 2 ships with factory-installed EMI/weatherproof plug and must remain plugged if not in use. Graphic shows the OCTIS connector in blue.
8	1	Optical Port 1	Connects to a Classic CAN or TEN (possibly through a local Hybrid Fiber Junction Box) and provides the main signal interface; if Secondary CAP L in a cascade, Optical Port 1 connects to Optical Port 2 of the Primary CAP L. Optical transport occurs over Single Mode Fiber (SMF) or Multi Mode Fiber (MMF). Uses the Optical OCTIS Kit (PN 7770612), which ships with the unit. Port 1 ships with a dust cap that can be discarded upon unit installation. Graphic shows the OCTIS connector in blue.
9	A	RJ45 Auxiliary port	Connects to external Ethernet devices such as WiFi and IP cameras. Cabling is via the appropriate CAT cable for the protocol; this model supports a 1000 BASE-T and 802.3at Class 4 Power over Cat6A Ethernet connection. Maximum attached cable length is 3 meters (9.8 feet). For information on the Auxiliary port in cascades, see "Cascade Rules for Fiber CAP Ls" on page 11. Port A ships with factory-installed EMI/weatherproof plug and must remain plugged if not in use. (Graphic shows the port populated with an OCTIS Ethernet connector PN 7760652 which must be ordered separately—see "OCTIS Kits" on page 9.)

CAP L Accessories and Options

The Fiber CAP L accessories and options are described in the following sections:

- "Fan Kit" on page 7
- "Mounting and Power Kits" on page 8
- "OCTIS Kits" on page 9

Fan Kit

Figure 3 shows the optional Fan Kit that is an integrated shroud that fits over a Fiber CAP L enclosure to extend the upper ambient temperature range. The Fan Kit

- is IP55 rated
- increases the maximum operating temperature to 55°C (131°F)
- adds 3W power consumption to the Fiber CAP L; see "Required Antenna Distances" on page 16.
- is factory installed but can be replaced in the field.

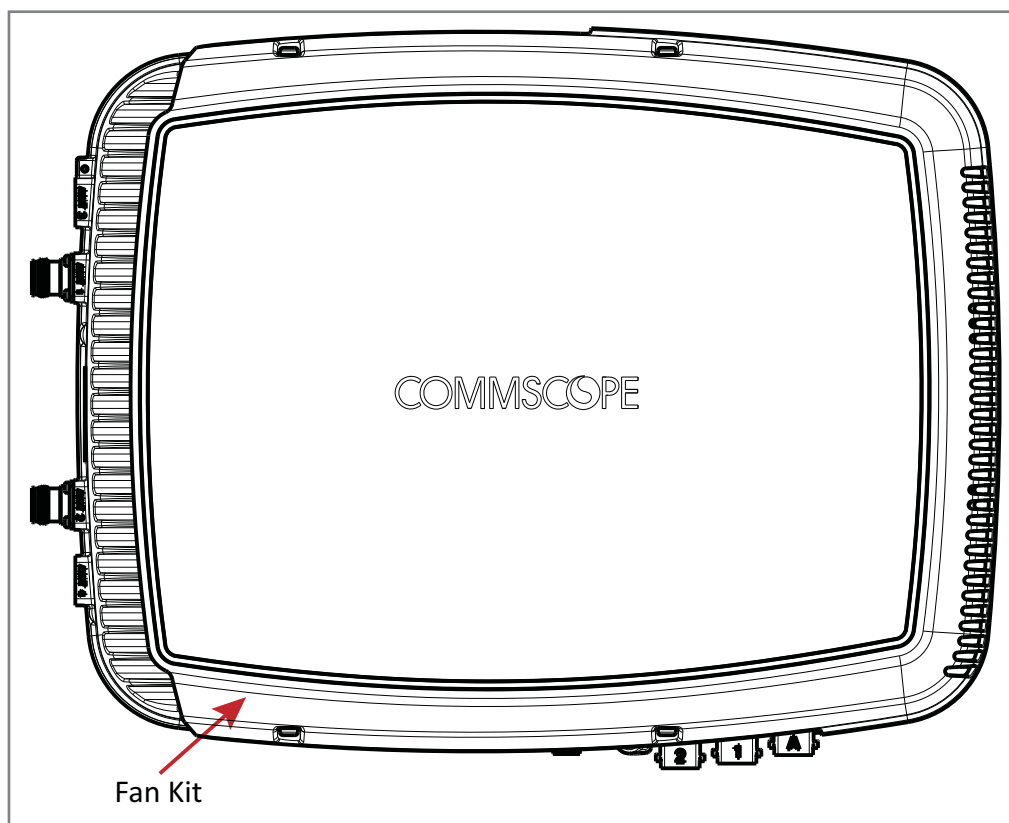

Figure 3. CAP L with the Optional Fan Kit

Figure 4 shows the proprietary 8-pin Fan Interface port, which is only available on Fiber CAP L units that ship with the factory-installed Fan Kit. If the Fiber CAP L being installed includes the Fan Kit option, the Fan Interface port will be cabled to the Fan Kit at the factory. If the Fiber CAP L being installed does not include the Fan Kit option, the Fan Interface port will be plugged.



Figure 4. Fan Interface Port

Mounting and Power Kits

CAP L Mounting and Power Kits are not included with the CAP L and must be ordered separately. Mounting and Power Kits are described in the applicable installation process:

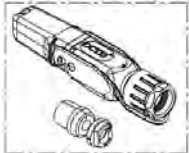

Table 3. Mounting and Power Kits

Mounting/Power Kit	CommScope PN	See
Flat Mounting Bracket Kit	7774353-xx	"Mounting a CAP L with a Flat Mounting Bracket Kit" on page 25
Dual Mounting Kit	7815440-xx	"Mounting Two CAP Ls with a Dual Mounting Kit" on page 31
Hybrid Fiber Splice Kit	7781091-xx	"Mounting a CAP L with a Hybrid Fiber Splice Box Kit" on page 43
Power Supply/Hybrid Fiber Mounting Kit	7774354-xx	"Mounting a CAP L with an AC/DC Power Supply Kit" on page 38
240W Local AC Power Supply Kit		"Mounting a CAP L with an AC/DC Power Supply Kit" on page 38
no AC Input Cord	7775087-xx	
with AC Input Cord for Plenum Space	7809798-xx 7809823-xx	

OCTIS Kits

All Fiber CAP Ls include one OCTIS¹ Kit for the primary interface to the Classic CAN or TEN. Regardless of which OCTIS Kit ships with the CAP L, it will plug into Port 1 on the CAP L. You must order an additional OCTIS Kit to cascade two CAP Ls, or to attach an auxiliary Ethernet device; which OCTIS Kit you should order is identified in [Table 4](#).

Table 4. CAP L OCTIS Kits

Kit Name	CommScope PN	Description
	Optical OCTIS Kit 7770612	This is the SFP+ connector that you use to cascade a Secondary Fiber CAP L; one Optical OCTIS Kit ships with each Fiber CAP L. Use as follows: <ul style="list-style-type: none"> • Optical Port 1—to connect the CAP M to a Classic CAN or TEN. • Optical Port 2—to cascade a second CAP M. • SFP+ Module must be ordered separately, it is not included as part of the Optical OCTIS Kit. • Ships with the following grommets: <ul style="list-style-type: none"> – 6mm nominal diameter for use with cables with OD range from 4.8-5.8 – 7mm nominal diameter for use with cables with OD range from 5.8-6.8 – 8mm nominal diameter for use with cables with OD range from 6.8-7.8
	Ethernet OCTIS Kit 7760652	This is the RJ-45 connector that you use to attach an auxiliary Ethernet device. The Ethernet OCTIS Kit must be ordered separately.

SFP+ Modules

The SFP+ Module installed in an OPT Card port is paired with another in Optical Port 1 of the Fiber CAP L. For a complete list of available SFP+ Modules, refer to the *Era™ Solution Ordering Guide*.

¹ OCTIS is a trademark of RADIALL.

PLAN AND PREPARE FOR A FIBER CAP L INSTALLATION

Do the following before beginning installation.

- 1 Review and know the information in "[Maximum Number of Fiber CAP Ls Supported in an Era System](#)" on [page 10](#).
- 1 Review and know the information in "[Cascade Rules for Fiber CAP Ls](#)" on [page 11](#).
- 2 Review and know the information in "[Safely Working with Era Hardware](#)" on [page 12](#).
- 3 "[Required Antenna Distances](#)" on [page 16](#).
- 4 "[Determine the CAP L Installation Site](#)" on [page 17](#), which includes understanding and meeting requirements for:
 - "[Recommended Tools and Material](#)" on [page 23](#)
 - "[CAP L Weights](#)" on [page 21](#)
 - "[Extended CAP L Temperature Operation](#)" on [page 22](#)
 - "[CAP L Dimensions](#)" on [page 18](#).
- 5 Map out all cable runs.
- 6 Identify and obtain all tools and materials required to complete the installation as described in "[Recommended Tools and Material](#)" on [page 23](#).
- 7 Obtain any accessories required for this installation; see "[CAP L Accessories and Options](#)" on [page 7](#).
- 8 "[Unpack and Inspect the CAP L and Optional Accessories](#)" on [page 23](#).

Maximum Number of Fiber CAP Ls Supported in an Era System

When installing a Fiber CAP L, you must observe the following rules.

- SMF or MMF connects the Fiber CAP L via its Optical Port 1 to the OPT Card.
- You connect CAP Ls to an OPT Card installed in Slots L1, L2, L3, or L4 in the TEN or Classic CAN.
 - Each OPT Card has four 10 Gbps ports (labeled 1 - 4) for fiber connections.
 - You can connect up to 4 CAP Ls per OPT Card for a total of 16 Primary and 32 total, per TEN or Classic CAN.



Fiber CAP Ls must be connected to OPT Cards installed in Slots L1, L2, L3, or L4 in a TEN or Classic CAN. OPT Cards installed in WCS Slots L5 - L8 cannot be used to connect APs.

Cascade Rules for Fiber CAP Ls

When cascading a Secondary Fiber CAP L or an external Ethernet device such as WiFi or an IP camera, you must observe the following rules.

- In a cascade, the CAP L connected directly to the Classic CAN or TEN is the Primary Fiber CAP L, and the CAP L that connects to the Primary Fiber CAP L is the Secondary Fiber CAP L.
- The cascaded unit must use the same transport type—you cannot cascade a Copper CAP L to a Fiber CAP L.
- The total 320 MHz RF bandwidth is shared between the two cascaded units, but can be shared unevenly; that is, with more bandwidth going to either the Primary or Secondary Fiber CAP L—either CAP L can transmit all the 320 MHz RF bandwidth or any subset of it.
- The Primary and Secondary Fiber CAP Ls power up as soon as power is applied to them. In a cascade, the Era GUI discovers and readies the Primary CAP L for RF first, and then the Secondary CAP L will be discovered and readied for RF. For information on the Power LED behavior, see ["Powering on a Fiber CAP L" on page 62](#).
- SMF or MMF from Optical Port 2 of the Primary Fiber CAP L connects to Optical Port 1 of the Secondary Fiber CAP L.
- You can connect the following to the Primary Fiber CAP L
 - a Secondary Fiber CAP L
 - an Ethernet device
 - both a Secondary Fiber CAP L (Port 2) and an Ethernet device (Aux Port).
- A cascaded CAP L pair can support one auxiliary device; the auxiliary device must be connected to Port A on the Primary Fiber CAP L, it cannot be connected to the Secondary CAP L.
- To add a Secondary AP, you must add an Optical OCTIS kit to the Primary CAP L, see ["OCTIS Kits" on page 9](#).
- To add an Ethernet device, you must add an RJ45 OCTIS kit to the Primary CAP L, see ["OCTIS Kits" on page 9](#).

Cat6A Cable Requirements for Ethernet Devices

If you connect an Ethernet device to a Fiber CAP L, you must observe the following rules.

- Plenum rated cable must be used whenever it is required by local electrical codes.
- Shielded twisted pair is not required unless operating in a high RFI/EMI environment.
- CommScope strongly recommends using factory terminated and tested Cat6A Patch Cord.
- 24 AWG Cat6A cabling is sufficient for the cable run between the Fiber CAP L and the Ethernet device.
- The maximum attached cable length from Port A on the Fiber CAP L to the Ethernet device is 3 meters (9.8 feet); see [Figure 5](#).

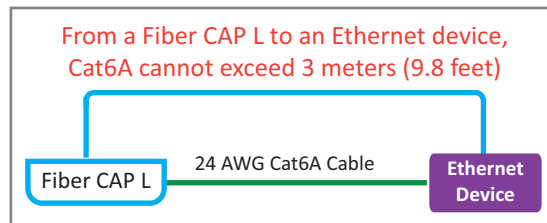

Figure 5. Maximum Cat6A Cable Length between a Fiber CAP L and an Ethernet Device

Safely Working with Era Hardware

The following sections provide important information that you should read and know before working with any Era hardware. Observe all cautions and warnings listed in this section.

Health and Safety Precautions



A high leakage current ground (earth) connection to the Power Supply Unit (PSU) is essential before making any other connections to the PSU.



Laser radiation. Risk of eye injury in operation. Do not stare into the laser beam; do not view the laser beam directly or with optical instruments.



High frequency radiation in operation. Risk of health hazards associated with radiation from the antenna(s) connected to the unit. Implement prevention measures to avoid the possibility of close proximity to the antenna(s) while in operation.

Property Damage Warnings



Keep operating instructions within easy reach and make them available to all users.



Only license holders for the respective frequency range are allowed to operate this unit.



Read and obey all the warning labels attached to the unit. Make sure that all warning labels are kept in a legible condition. Replace any missing or damaged labels.



Make sure the unit's settings are correct for the intended use (refer to the manufacturer product information) and regulatory requirements are met. Do not carry out any modifications or fit any spare parts, which are not sold or recommended by the manufacturer.

General Installation Safety Requirements



Wet conditions increase the potential for receiving an electrical shock when installing or using electrically powered equipment. To prevent electrical shock, never install or use electrical equipment in a wet location or during a lightning storm.



This system is a RF Transmitter and continuously emits RF energy. Maintain a minimum clearance from the antenna as specified in [Table 6](#) while the system is operating. Whenever possible, power down the CAP L before servicing the antenna.



Do not remove caps from any of the connectors until instructed to do so.



The CAP L is to be used only with CommScope (NEC Class 2) or Limited Power Source Era Subrack, or equivalent.

Guard Against Damage from Electro-Static Discharge



Electro-Static Discharge (ESD) can damage electronic components. To prevent ESD damage, always wear an ESD wrist strap when working with Era hardware components. Not all Era hardware requires grounding. For those Era hardware components for which grounding is required, connect the ground wire on the ESD wrist strap to an earth ground source before touching the Era component. Wear the wrist strap the entire time that you work with the Era hardware.

Compliance

- 1 Notice:** For installations, which have to comply with FCC RF exposure requirements, the antenna selection and installation must be completed in a way to ensure compliance with those FCC requirements. Depending on the RF frequency, rated output power, antenna gain, and the loss between the repeater and antenna, the minimum distance D to be maintained between the antenna location and human beings is calculated according to this formula:

$$D_{[cm]} = \sqrt{\frac{P_{[mW]}}{4 * \pi * PD_{[mW/cm^2]}}}$$

where

- P (mW) is the radiated power at the antenna, i.e. the max. rated repeater output power in addition to the antenna gain minus the loss between the repeater and the antenna.
- PD (mW/cm²) is the allowed Power Density limit acc. to 47 CFR 1.1310 (B) for general population / uncontrolled exposures which is
 - f (MHz) / 1500 for frequencies from 300MHz to 1500MHz
 - 1 for frequencies from 1500MHz to 100,000MHz

RF exposure compliance may need to be addressed at the time of licensing, as required by the responsible FCC Bureau(s), including antenna co-location requirements of 1.1307(b)(3).

- 2 Notice:** For installations which have to comply with European EN50385 exposure compliance requirements, the following Power Density limits/guidelines (mW/cm²) according to ICNIRP are valid:
 - 0.2 for frequencies from 10 MHz to 400 MHz
 - F (MHz) / 2000 for frequencies from 400 MHz to 2 GHz
 - 1 for frequencies from 2 GHz to 300 GHz
- 3 Notice:** Installation of this equipment is in full responsibility of the installer, who has also the responsibility, that cables and couplers are calculated into the maximum gain of the antennas, so that this value, which is filed in the FCC Grant and can be requested from the FCC data base, is not exceeded. The industrial boosters are shipped only as a naked booster without any installation devices or antennas as it needs for professional installation.
- 4 Notice:** For installations which have to comply with FCC/ISED requirements:

English:

This device complies with FCC Part 15. Operation is subject to the following two conditions: (1) this device may not cause interference, and (2) this device must accept any interference, including interference that may cause undesired operation of the device.

This device complies with Health Canada's Safety Code. The installer of this device should ensure that RF radiation is not emitted in excess of the Health Canada's requirement. Information can be obtained at http://www.hc-sc.gc.ca/ewh-semt/pubs/radiation/radio_guide-lignes_direct-eng.php.

Changes or modifications not expressly approved by the party responsible for compliance could void the user's authority to operate the equipment.

Antenna Stmt for ISED:

This device has been designated to operate with the antennas having a maximum gain of 9 dBi. Antennas having a gain greater than 9 dBi are prohibited for use with this device without consent by ISED regulators. The required antenna impedance is 50 ohms.

The antenna(s) used for this transmitter must be installed to provide a minimum separation distance (as specified in [Table 6](#)) from all persons and must not be co-located or operating in conjunction with any

other antenna or transmitter. Users and installers must be provided with antenna installation instructions and transmitter operating conditions for satisfying RF exposure compliance.

French:

Cet appareil est conforme à FCC Partie 15. Son utilisation est soumise à Les deux conditions suivantes: (1) cet appareil ne peut pas provoquer d'interférences et (2) cet appareil doit accepter Toute interférence, y compris les interférences qui peuvent causer un mauvais fonctionnement du dispositif.

Cet appareil est conforme avec Santé Canada Code de sécurité 6. Le programme d'installation de cet appareil doit s'assurer que les rayonnements RF n'est pas émis au-delà de l'exigence de Santé Canada. Les informations peuvent être obtenues:

http://www.hc-sc.gc.ca/ewh-semt/pubs/radiation/radio_guide-lignes_direct-eng.php

Les changements ou modifications non expressément approuvés par la partie responsable de la conformité pourraient annuler l'autorité de l'utilisateur à utiliser cet équipement.

Antenne Stmt pour ISDE:

Ce dispositif a été désigné pour fonctionner avec les antennes ayant un gain maximal de 9 dBi. Antennes ayant un gain plus grand que 9 dBi sont interdites pour une utilisation avec cet appareil sans le consentement des organismes de réglementation d'ISDE. L'impédance d'antenne requise est 50 ohms.

L'antenne (s) utilisé pour cet émetteur doit être installé pour fournir une distance de séparation minimale (comme indiqué dans le [Table 6](#)) par rapport à toute personnes et ne doit pas être co-localisées ou opérant en conjonction avec une autre antenne ou émetteur. Les utilisateurs et les installateurs doivent être fournis avec des instructions d'installation de l'antenne et des conditions de fonctionnement de l'émetteur pour satisfaire la conformité aux expositions RF.

- 5 Notice:** The unit complies with Overvoltage Category II. It also complies with the surge requirement according to EN 61000-4-5 (fine protection); however, installation of an additional medium (via local supply connection) and/or coarse protection (external surge protection) is recommended depending on the individual application in order to avoid damage caused by overcurrent.

For Canada and US, components used to reduce the Overvoltage Category shall comply with the requirements of IEC 61643-series. As an alternative, components used to reduce the Overvoltage Category may comply with ANSI/IEEE C62.11, CSA Certification Notice No. 516, CSA C22.2 No. 1, or UL 1449. Suitability of the component for the application shall be determined for the intended installation.

- 6 Notice:** Corresponding local particularities and regulations must be observed. For national deviations, please refer to the respective documents included in the manual CD that is delivered with the unit.
- 7 Note:** For a Class B digital device or peripheral:

This equipment has been tested and found to comply with the limits for a Class B digital device, pursuant to part 15 of the FCC Rules. These limits are designed to provide reasonable protection against harmful interference in a residential installation. This equipment generates, uses and can radiate radio frequency energy and, if not installed and used in accordance with the instructions, may cause harmful interference to radio communications. However, there is no guarantee that interference will not occur in a particular installation. If this equipment does cause harmful interference to radio or television reception, which can be determined by turning the equipment off and on, the user is encouraged to try to correct the interference by one or more of the following measures:

- Reorient or relocate the receiving antenna.
- Increase the separation between the equipment and receiver.
- Connect the equipment into an outlet on a circuit different from that to which the receiver is connected.
- Consult the dealer or an experienced RF technician for help.

8 Notice: For a Class A digital device or peripheral.

This equipment has been tested and found to comply with the limits for a Class A digital device, pursuant to Part 15 of the FCC Rules. These limits are designed to provide reasonable protection against harmful interference when the equipment is operated in a commercial environment. This equipment generates, uses, and can radiate radio frequency energy and, if not installed and used in accordance with the instruction manual, may cause harmful interference to radio communications. Operation of this equipment in a residential area is likely to cause harmful interference in which case the user will be required to correct the interference at his own expense.

9 Note: This unit complies with European standard EN60950-1 / EN62368-1.

Equipment Symbols Used / Compliance

Please observe the meanings of the following symbols used in our equipment and the compliance warnings listed in [Table 5](#).

Table 5. Compliance Labels

Symbol	Compliance	Meaning
—	FCC	For industrial (Part 20) signal booster: WARNING: This is NOT a CONSUMER device. It is designed for installation by FCC LICENSEES and QUALIFIED INSTALLERS. You MUST have an FCC LICENSE or express consent of an FCC Licensee to operate this device. Unauthorized use may result in significant forfeiture penalties, including penalties in excess of \$100,000 for each continuing violation.
		For (Part 90) signal booster: WARNING: This is NOT a CONSUMER device. It is designed for installation by FCC LICENSEES and QUALIFIED INSTALLERS. You MUST have an FCC LICENSE or express consent of an FCC Licensee to operate this device. You MUST register Class B signal boosters (as defined in 47 CFR 90.219) online at www.fcc.gov/signal-boosters/registration . Unauthorized use may result in significant forfeiture penalties, including penalties in excess of \$100,000 for each continuing violation.
—	ISED	WARNING: This is NOT a CONSUMER device. It is designed for installation by an installer approved by an ISED licensee. You MUST have an ISED LICENCE or the express consent of an ISED licensee to operate this device. AVERTISSEMENT: Ce produit N'EST PAS un appareil de CONSOMMATION. Il est conçu pour être installé par un installateur approuvé par un titulaire de licence d'ISDE. Pour utiliser cet appareil, vous DEVEZ détenir une LICENCE d'ISDE ou avoir obtenu le consentement exprès d'un titulaire de licence autorisé par ISDE.
CE	CE	To be sold exclusively to mobile operators or authorized installers - no harmonized frequency bands, operation requires license. Intended use: EU and EFTA countries.
		Indicates conformity with the RED directive 2014/53/EU and/or RoHS directive 2011/65/EU.

Required Antenna Distances

Table 6. Required Antenna Distances

CAP L Model	Antenna gain without cable loss [dBi]	Minimum Distance Between Antennas and All Persons			
		FCC		ISED	
		Meters	Inches	Meters	Inches
CAP L 7/80-85/17E/19	9	.176	6.9	.256	10.1
CAP L 17E/17E/19/19	9	.218	8.58	.259	10.2
CAP L 17E/17E/23/23	9	.169	6.65	.237	9.33
CAP L 17E/19/23/25TDD	9	.178	7.02	.251	9.88

Determine the Power Consumption of the CAP L

Use the power consumption matrix in [Table 7](#) to calculate power consumption for a Fiber CAP L, where

- the consumption numbers are at the CAP L power inputs and do not account for feed losses
- the maximum consumption numbers in [Table 7](#) do not include the power consumed by any attached auxiliary devices. Both CAP L power consumption and auxiliary device power must be included when calculating feed losses.

Table 7. CAP L Power Consumption

Configuration	Voltage Range (V)	Typical Power (W)	Maximum Power (W)
Fiber CAP L without Fan Kit ^{1,2}	36 - 60	92	102
Fiber CAP L with Fan Kit ^{1,2}	36 - 60	95	107
<p>1 Does not include consumption of optional local DC supply.</p> <p>2 Optical unit does not include SFP+ Module consumption. Can support up to 3W (more with engineering consultation) maximum total SFP+ Module consumption. Typical installation (sufficient for SM up to 10km or MM) would be 0.8W typical, 1.0W max for each SFP+ Module.</p>			

Determine the CAP L Installation Site

When deciding on a suitable mounting site, observe the following rules; refer also to "[Mounting Orientation for Wall Mounts](#)" on page 29.

- The Fiber CAP L is suitable for indoor installation.
- CommScope recommends that a Fiber CAP L be installed outdoors only if it has a Fan Kit.

The following sections provides weight and dimension requirements needed to determine the best installation site for the Fiber CAP L.

CAP L Dimensions

Use the dimensions shown in the section applicable to this installation to determine the space required at the mounting site.

Mounting Dimensions for a CAP L with the Flat Mounting Bracket Kit

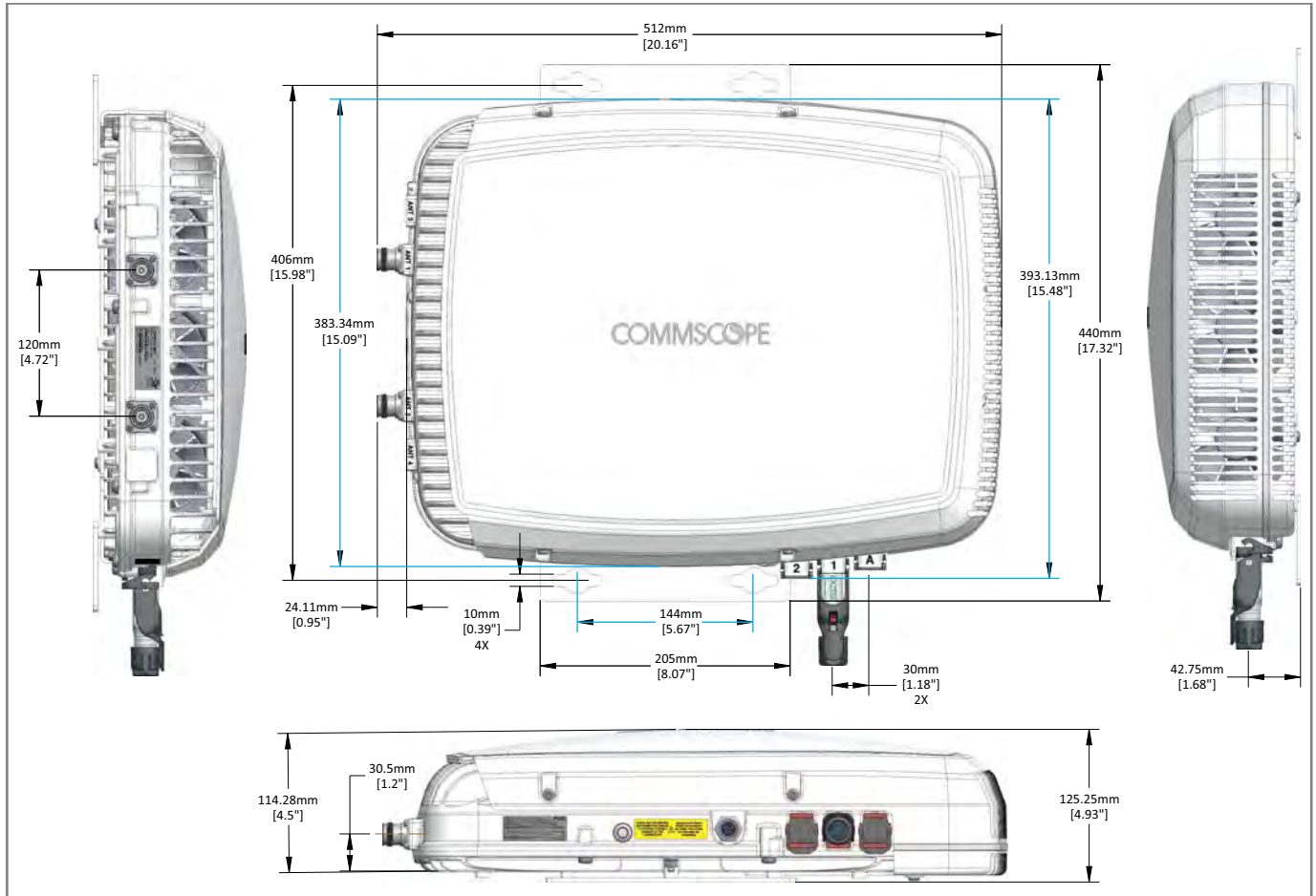

Mounting Dimensions for Two CAP Ls Mounted with the Dual Mounting Kit

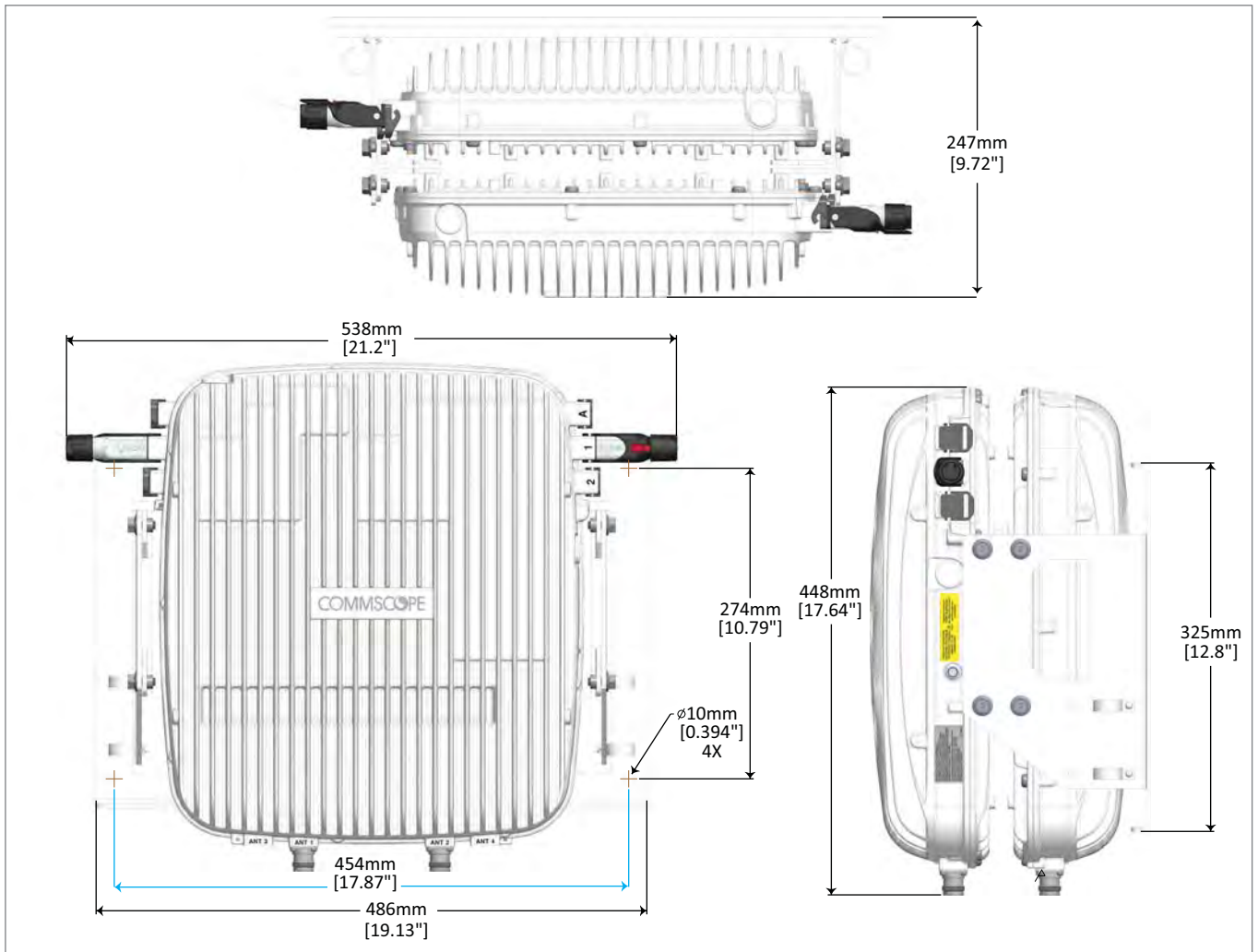

Mounting Dimensions for a CAP L Mounted with the CAP L Hybrid Fiber Splice Box Kit

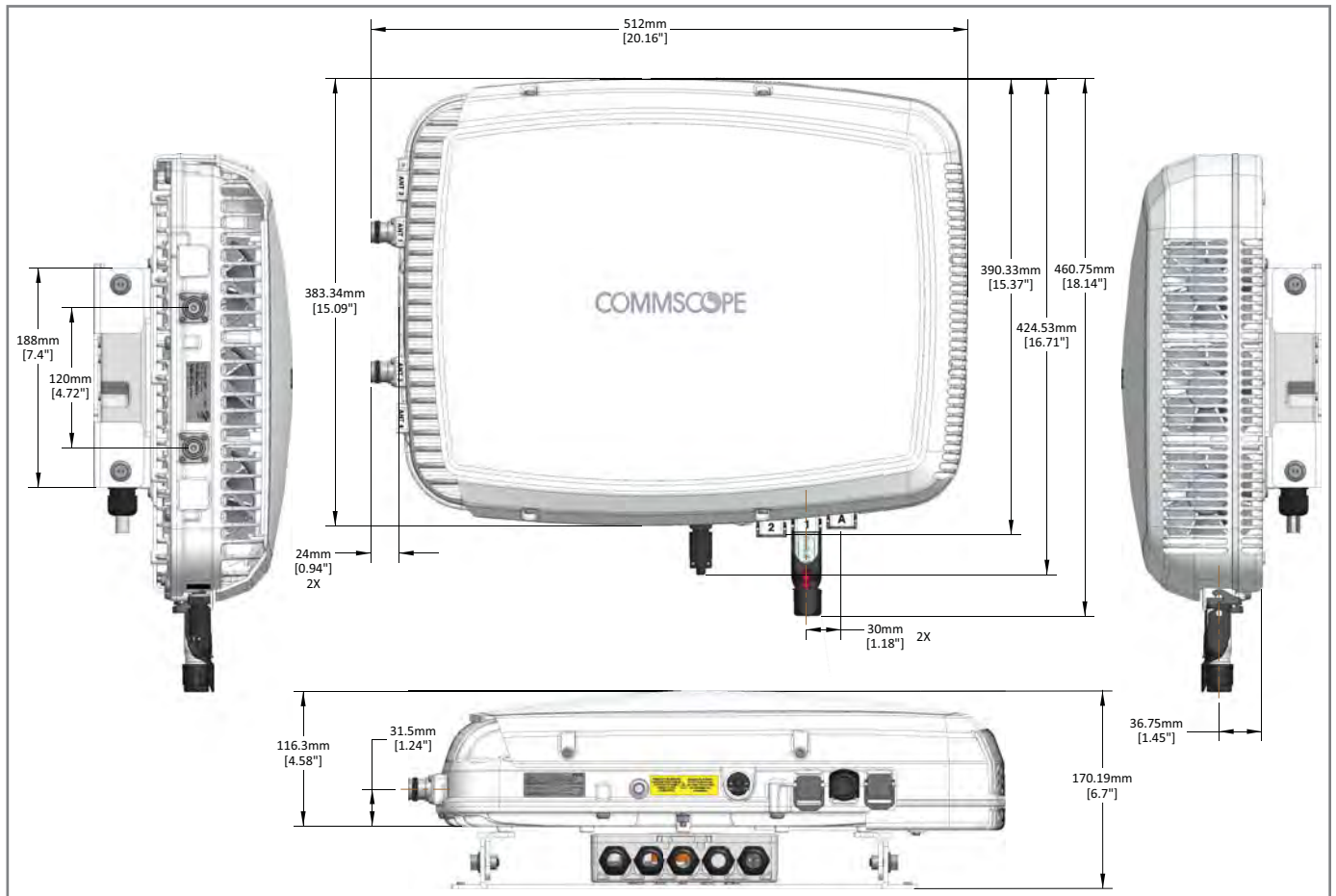

Mounting Dimensions for a CAP L Mounted with the AC/DC Power Supply Kit

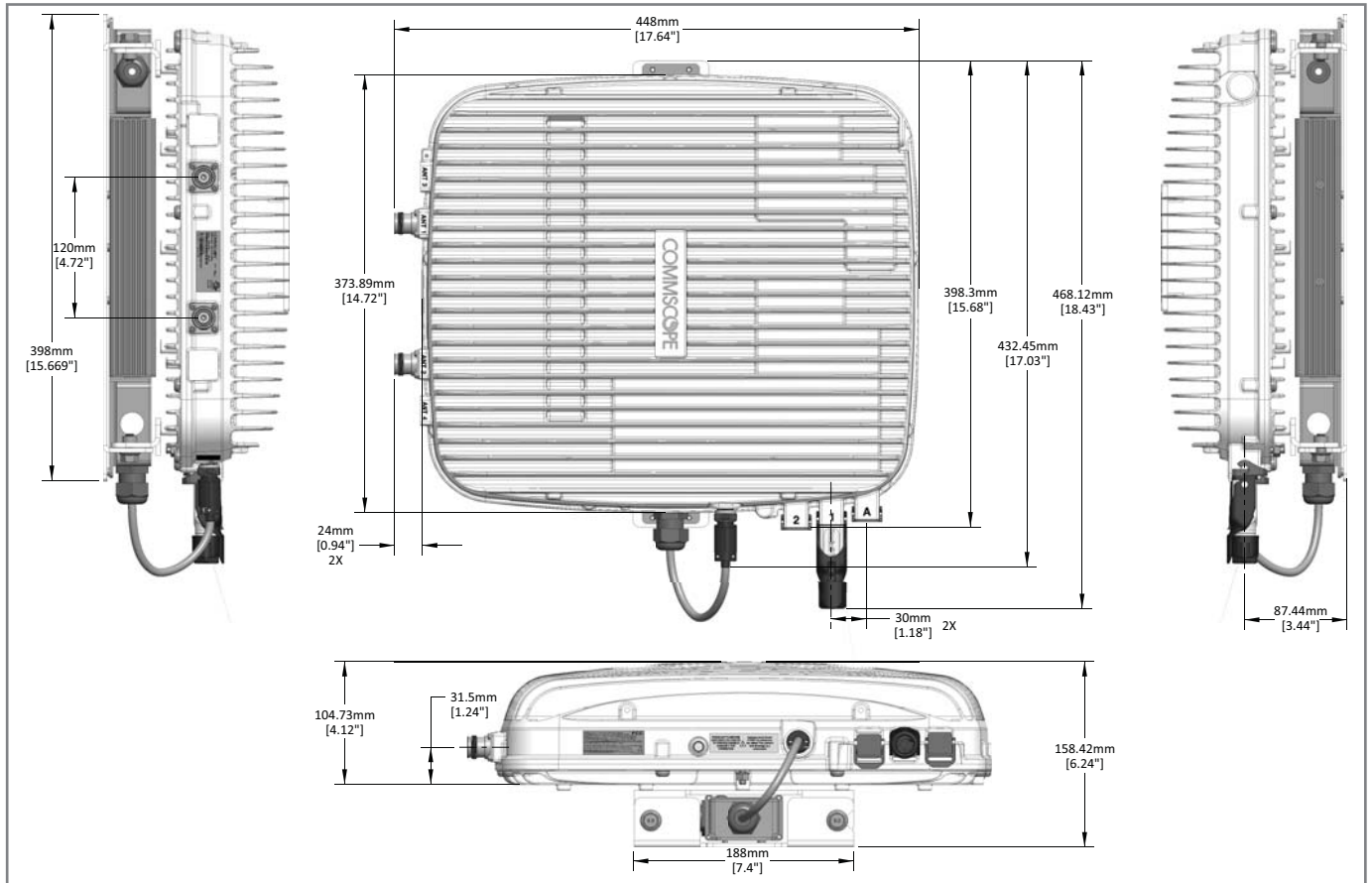

CAP L Weights

Use the weights listed in [Table 8](#) to determine a site that can bear the weight of the Fiber CAP L that is being installed, where:

- The “Maximum Lift Weight” is the highest weight that must be lifted during installation. (An installer only needs to lift CAP L components at one time, not the wholly configured CAP L.)
- The “Total Hanging Weight” is the weight of the CAP L, including the weight of the Mounting Bracket and Power Supply, minus the weight of the external cables and connectors, that the mounting site must be able to support.

Table 8. Maximum CAP L Installation Weights*

CAP L configured with this kit ...	Maximum Lift Weight				Total Hanging Weight			
	No Fan Kit		With Fan Kit		No Fan Kit		With Fan Kit	
	kg	lbs.	kg	lbs.	kg	lbs.	kg	lbs.
Flat Mounting Bracket	10.8	23.8	11.3	25	10.8	23.8	11.3	25
Dual Mounting Bracket	10.9	24.1	N/A		23.4	51.6	N/A	
AC/DC Power Supply Kit	10.7	23.6	11.2	24.7	13.2	29	13.7	30.2
CAP L Hybrid Fiber Splice Box Kit	10.7	23.6	11.2	24.7	12.2	26.9	12.7	28



Extended CAP L Temperature Operation

The passively cooled CAP L is rated for a maximum temperature of 40°C (104°F). This temperature range guarantees maximum service life under worst-case load conditions. If necessary, however, it can be operated safely at higher temperatures without exceeding the maximum temperatures of the internal electronic components.

Various components in the CAP L have temperature sensors and will alarm once they get within about 5 degrees of their maximum allowed temperature. The CAP L will disable itself if any of the internal temperatures exceeds the maximum allowed temperature.

The maximum ambient temperature of the CAP L is dependent on the mounting configuration, as the mounting configuration affects the ability of the CAP L to dissipate heat. The various mounting configurations and resulting temperature ranges of operation are detailed in [Table 9](#).

Table 9. CAP L Extended Temperature Operation by Mounting Orientation

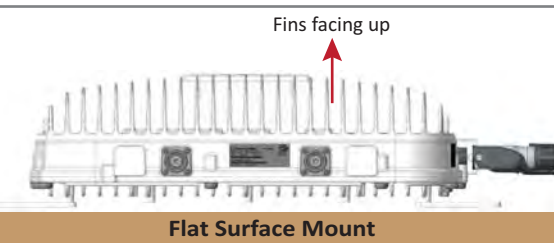
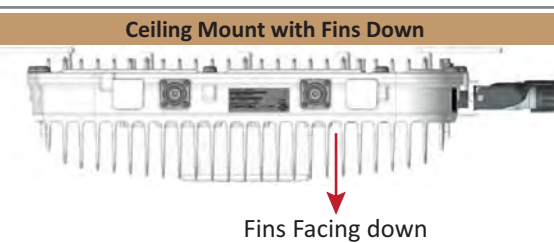
Mounting Orientation	Recommended Maximum Ambient Temperature (Alarm Threshold)	Absolute Maximum Ambient Temperature (Shutdown Temp.)
 <p style="text-align: center;">Vertical Mount</p>	60 °C (140°F)	65 °C (149°F)
 <p style="text-align: center;">Dual Vertical Mount</p>	58 °C (136.4°F)	63 °C (145.4°F)
 <p style="text-align: center;">Flat Surface Mount</p>	54 °C (129.2°F)	59 °C (138.2°F)
 <p style="text-align: center;">Ceiling Mount</p>	48 °C (118.4°F)	53 °C (127.4°F)

Recommended Tools and Material

- Electrostatic Discharge (ESD) wrist strap
- Drill and bits to mount the to a wall or ceiling
- Fiber cleaning equipment
- if required per local practice, insulated stranded copper wire for chassis ground; see "[Ground the Fiber CAP L \(Optional\)](#)" on page 55.

Unpack and Inspect the CAP L and Optional Accessories

- 1 Inspect the exterior of the shipping container(s) for evidence of rough handling that may have damaged the components in the container.
- 2 Unpack each container while carefully checking the contents for damage and verify with the packing slip.
- 3 If damage is found or parts are missing, file a claim with the commercial carrier and notify CommScope Technical Support (see "[CMS Global Technical Support](#)" on page 64). Save the damaged cartons for inspection by the carrier.
- 4 Save all shipping containers for use if the equipment requires shipment at a future date.

Obtain the Required Materials

Contact your local CommScope sales representative to obtain the following components, as required, for this installation.

- Obtain the cable required for this installation.
 - Per the installation plan, obtain either Single Mode Fiber (SMF) or Multi Mode Fiber (MMF) that is of sufficient length to reach from the CAP L to the Classic CAN or TEN. In a cascade, the Primary Fiber CAP L connects to the Classic CAN or TEN.
 - If you are cascading a Secondary Fiber CAP L to the Primary Fiber CAP L, you also need a sufficient length of fiber to run between the two CAP Ls.
 - If you are connecting an external Ethernet device such as WiFi or IP camera, appropriate CAT cable for the protocol to which the Fiber CAP L will connect is required. This model supports a 1000 BASE-T and 802.3at Class 4 Power over Cat6A Ethernet connection. For the CAT cable, follow the rules in "[Cat6A Cable Requirements for Ethernet Devices](#)" on page 12.
 - Per the installation plan, obtain 50Ω coaxial cables that are of sufficient length to reach from the CAP L to the passive RF antenna. The end of the 50Ω coaxial cable that will connect to the ANT connector can be either a push-pull connector or a threaded connector.
- Obtain the Optical OCTIS Kits required for this installation; see "[OCTIS Kits](#)" on page 9.
- Obtain SFP+ Module pairs that are appropriate for this installation; see "[SFP+ Modules](#)" on page 9.
- Obtain the Mounting Kits for the installation. Mounting Kits are not included with the CAP L and must be ordered separately.

MOUNT THE FIBER CAP L

A Fiber CAP L is suitable for indoor and outdoor installations as follows:

- Indoors—All versions of the Fiber CAP L can be installed indoors.
- Outdoors—Only Fiber CAP Ls with the optional Fan Kit can be installed outdoors.

Mounting instructions are divided into the sections listed below. Follow the mounting instructions that are applicable to this installation:

- ["Flat-Surface Mount a CAP L" on page 27](#)
- ["Wall Mount a CAP L" on page 29](#)
 - ["Mounting Orientation for Wall Mounts" on page 29](#)
 - ["Wall Mount a CAP L Using a Flat Mounting Bracket Kit" on page 30](#)
 - ["Mounting Two CAP Ls with a Dual Mounting Kit" on page 31](#)
 - ["Mounting a CAP L with an AC/DC Power Supply Kit" on page 38](#)
 - ["Mounting a CAP L with a Hybrid Fiber Splice Box Kit" on page 43](#)
- ["Ceiling Mount a CAP L" on page 54](#)
 - ["Ceiling Mount a CAP L without a Fan Kit" on page 54](#)
 - ["Ceiling Mount a CAP L with a Fan Kit" on page 54.](#)

General Mounting Cautions

The following cautions apply to all Fiber CAP L installations; there may be other mounting cautions applicable to a specific mounting option, which will be defined in the applicable mounting procedure.



Attach all CAP Ls securely to a stationary object as described in this installation guide.



To maintain proper ventilation, keep at least 76 mm (3-inch) clearance around the CAP L.



The installation site must be able to bear the weight of the CAP L; see [Table 8 on page 21](#).

Mounting a CAP L with a Flat Mounting Bracket Kit

Figure 6 shows the Flat Mounting Bracket Kit (CommScope PN 7774353-xx), which provides the mounting brackets required to mount a Fiber CAP L to a wall or other flat surface.

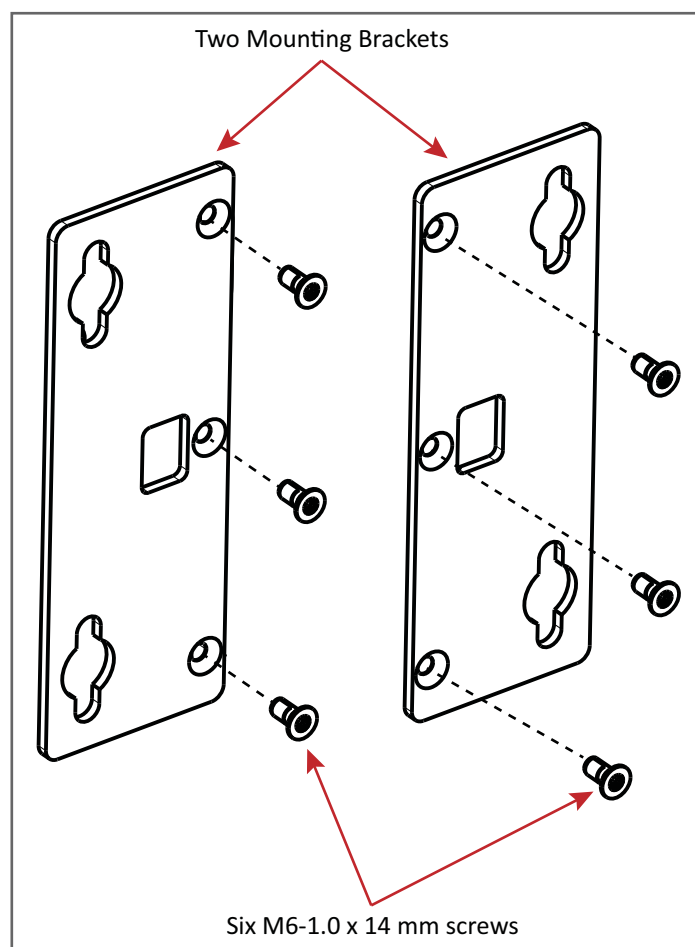

Figure 6. Flat Mounting Bracket Kit (PN 7774353-xx)

Attach the Flat Mounting Bracket Kit to the CAP L

Attach the two mounting brackets to the back of the CAP L enclosure as described below and as shown in [Figure 7](#) (Fiber CAP L with a Fan Kit) and [Figure 8 on page 27](#) (Fiber CAP L without Fan Kit).

- 1 Use "[Plan and Prepare for a Fiber CAP L Installation](#)" on [page 10](#) to identify the installation site and installation requirements, and to prepare for this installation.
- 2 Refer to and observe all cautions listed in "[General Mounting Cautions](#)" on [page 24](#).
- 3 Use three of the M6-1.0 x14mm screws that came with the Flat Mounting Bracket Kit to attach the left or top mounting bracket to the three corresponding horizontal or vertical M6-1.0 mounting taps on the back of the CAP L chassis.
- 4 Use three of the M6-1.0 x14mm screws that came with the Flat Mounting Bracket Kit to attach the right or bottom mounting bracket to the three corresponding horizontal or vertical M6-1.0 mounting taps on the back of the CAP L chassis.

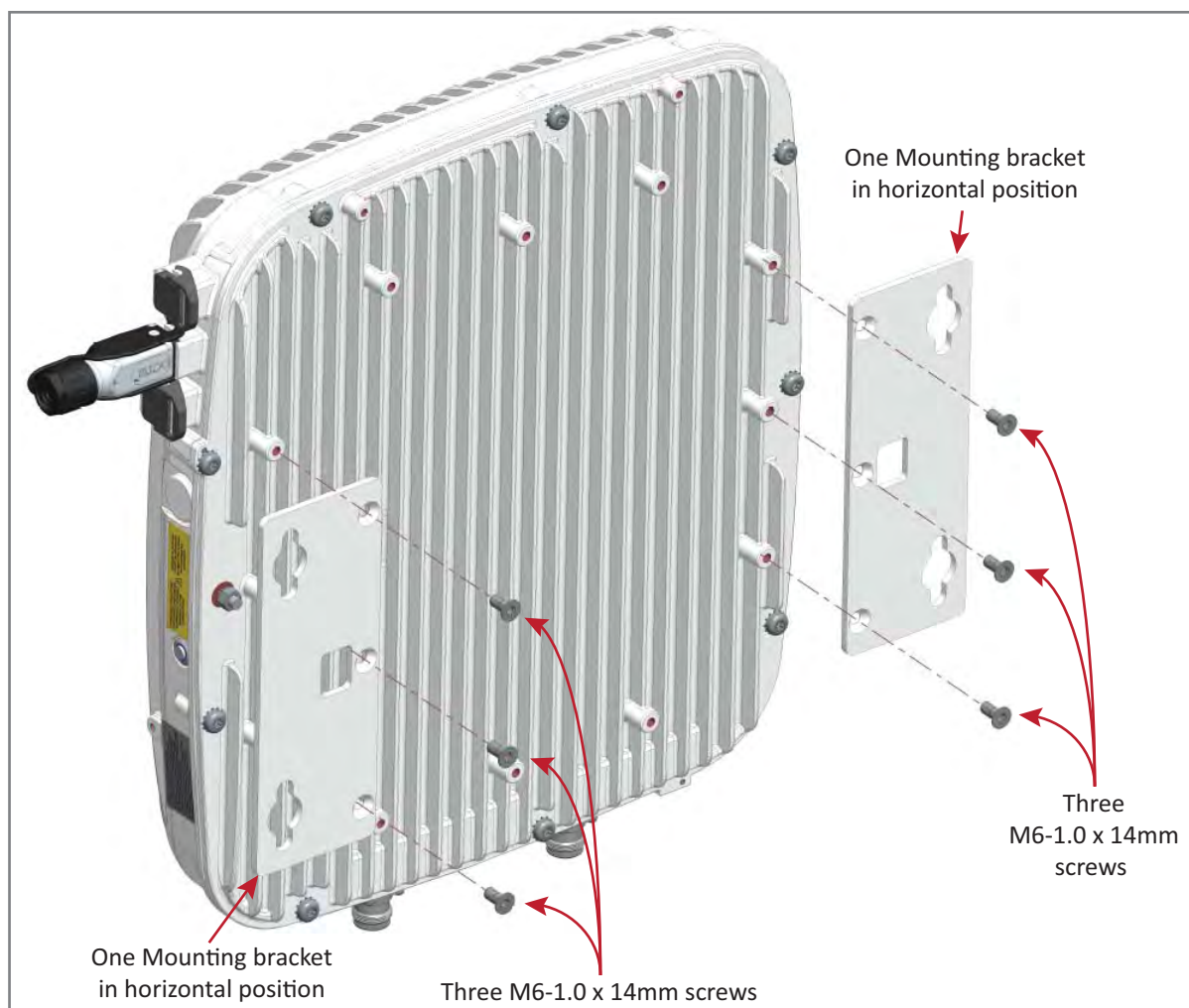

Figure 7. Fiber CAP L (No Fan Kit) with Flat Mounting Bracket Kit (PN 7774353-xx)

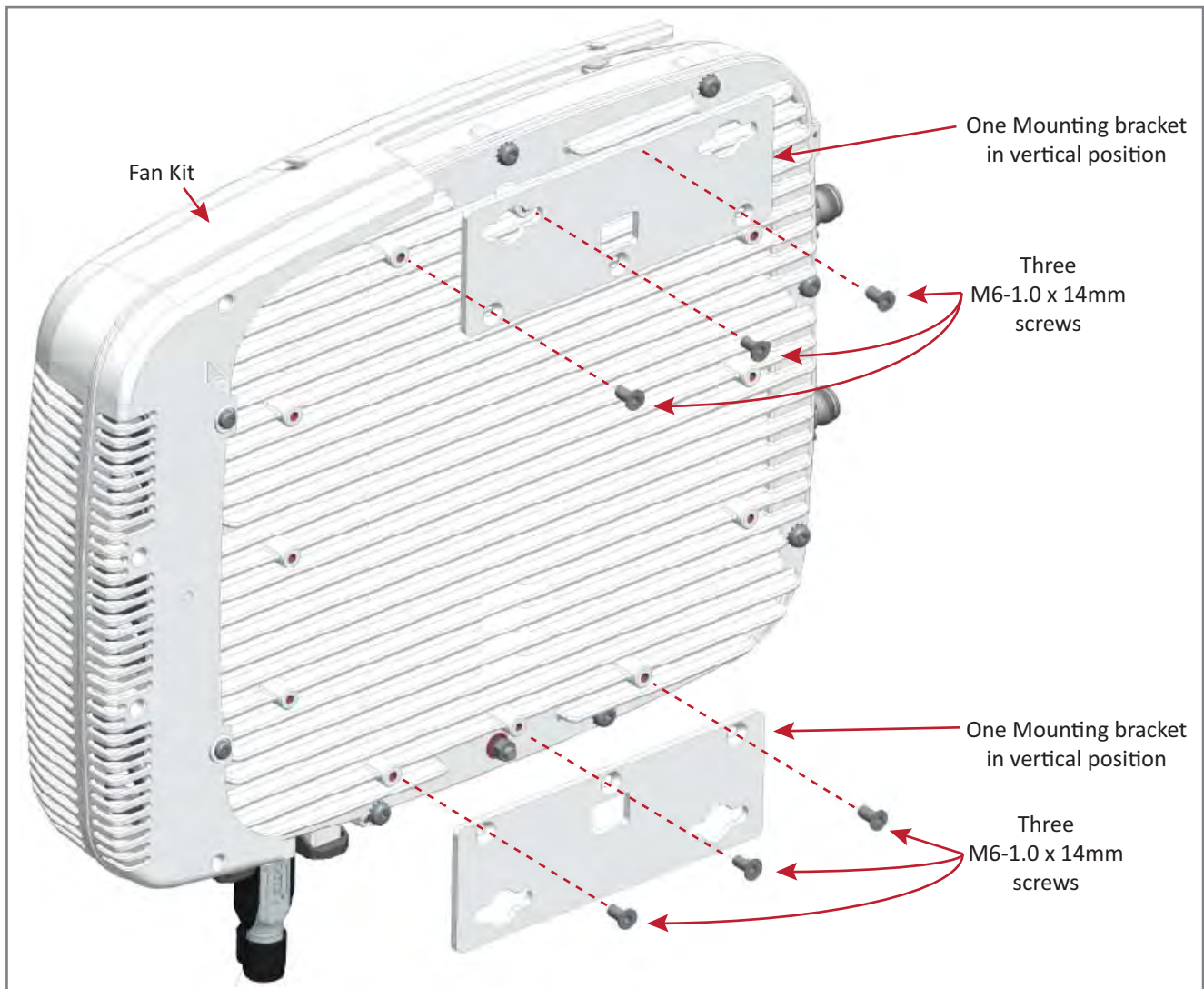

Figure 8. Fiber AP L with a Fan Kit and Flat Mounting Bracket Kit (PN 7774353-xx)

Flat-Surface Mount a CAP L

You can place a Fiber CAP L on a flat surface, such as a shelf, desk, cabinet, above a ceiling, or any other horizontal surface that allows stable placement.

Do the following to flat-surface mount a Fiber CAP L:

- 1 Use "[Plan and Prepare for a Fiber CAP L Installation](#)" on page 10 to identify the installation site and installation requirements, and to prepare for this installation.
- 2 In addition to the cautions listed in "[General Mounting Cautions](#)" on page 24, observe the rules that are specific to a flat-surface mounts listed below and elsewhere in this section.



To maintain proper ventilation, keep at least 76 mm (3-inch) clearance around the CAP L.



If a CAP L without a Fan Kit is flat-surface mounted, the minimum clearance above the CAP L is 203.2 millimeters (8 inches).



Do not stack CAP Ls on top of each other.



Always secure the CAP L to the mounting surface.

- 3 Follow the steps in ["Attach the Flat Mounting Bracket Kit to the CAP L"](#) on page 26.
- 4 Refer to the following graphic to see the correct way to flat-surface mount a Fiber CAP L.

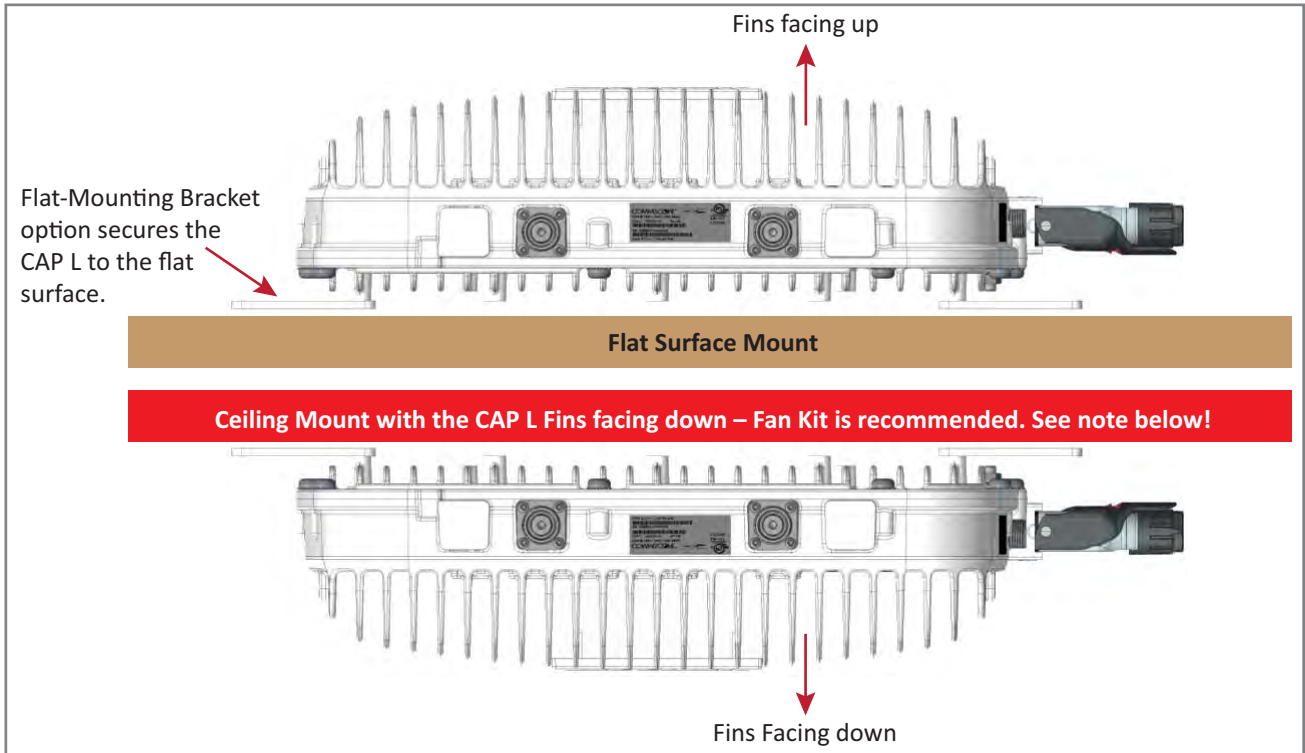

Always mount the CAP L with its mounting option facing down against the mounting surface, and the enclosure fins facing up for optimal cooling efficiency, as shown in the preceding graphic. Cooling efficiency is reduced when the enclosure fins are facing down; a fan kit is recommended for maximum service life when the CAP L is mounted in this orientation. For further details on installation without a fan kit, see ["Extended CAP L Temperature Operation"](#) on page 22.



If you are mounting the CAP L above a ceiling, its antennas must protrude below the ceiling. That is, the CAP L will be above the ceiling, but any connected WiFi units or IP cameras will be mounted below the ceiling, as shown in the preceding graphic.

- 5 After you mount the Fiber CAP L on a flat surface, follow the steps in
 - ["Ground the Fiber CAP L \(Optional\)"](#) on page 55 (if grounding is required or preferred)
 - ["Connect the Passive RF Antenna"](#) on page 59.

Wall Mount a CAP L

The following sections provide the installation methodology and steps required to mount a Fiber CAP L to a wall.

Mounting Orientation for Wall Mounts

When wall mounting a Fiber CAP L, the recommendations should be observed.

- **Wall Mount Orientation for a CAP L without a Fan Kit**



A CAP L that does not have a Fan Kit is passively cooled. You should therefore mount a CAP L that does not have a Fan Kit with the ANT ports pointing down (see [Figure 9](#)). Otherwise, the CAP L will have a reduced maximum operating temperature of 33°C (91°F).

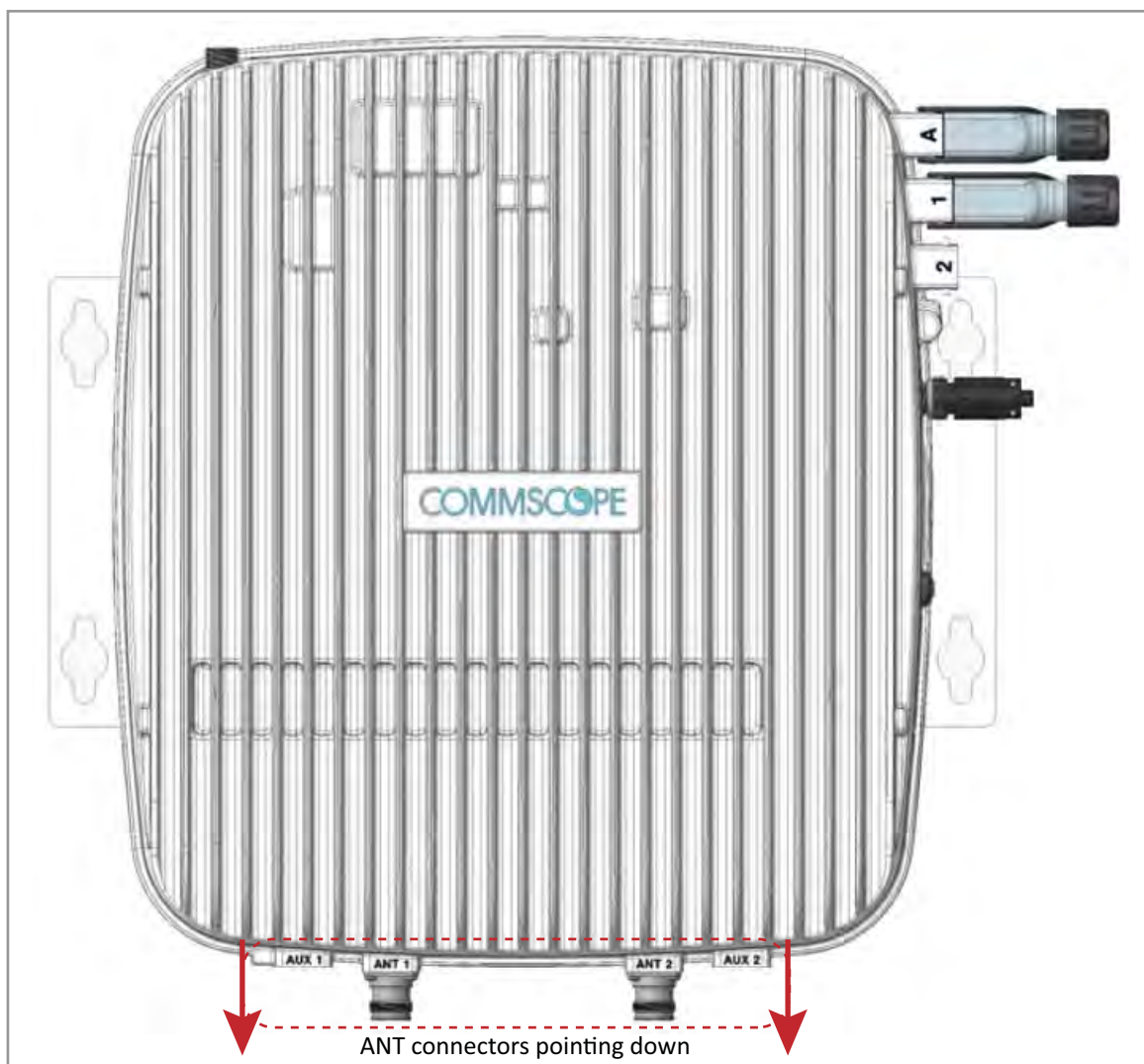

Figure 9. Mounting Orientation for a CAP L without the Optional Fan Kit (Flat Mounting Bracket Shown)

- **Wall Mount Orientation for a CAP L with a Fan Kit**—To allow for optimal access to the CAP L cables, it is recommended that a Fiber CAP L with the Fan Kit option be mounted with the ANT ports pointing to the left; see [Figure 10](#).

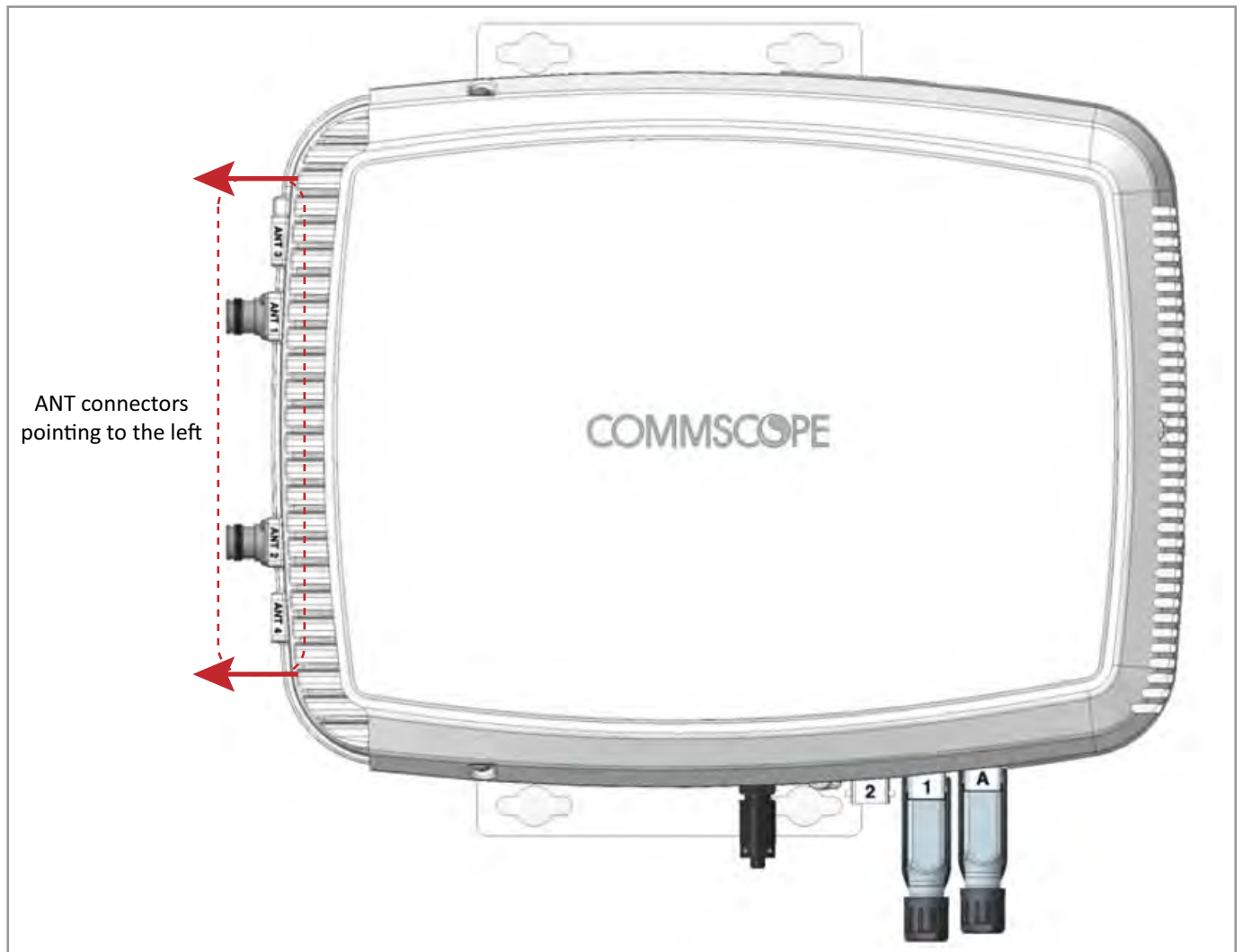

Figure 10. Mounting Orientation for a CAP L with the Optional Fan Kit (Flat Mounting Bracket Shown)



Mounting requirements for flat surfaces are described in ["Flat-Surface Mount a CAP L"](#) on page 27. Ceiling-mount requirements are described in ["Ceiling Mount a CAP L with a Fan Kit"](#) on page 54.

Wall Mount a CAP L Using a Flat Mounting Bracket Kit

- 1 Use ["Plan and Prepare for a Fiber CAP L Installation"](#) on page 10 to identify the installation site and installation requirements, and to prepare for the installation.
- 2 Refer to and observe all cautions listed in ["General Mounting Cautions"](#) on page 24.
- 3 Follow the steps in ["Attach the Flat Mounting Bracket Kit to the CAP L"](#) on page 26.
- 4 Refer to ["Mounting Orientation for Wall Mounts"](#) on page 29 to determine the mounting orientation of the Fiber CAP L.

- 5 Use four 5/16-inch or M8 lag screws (or whatever screw type is appropriate for the material to which the Fiber CAP L is to be mounted on) to mount the CAP L to the wall.
- 6 After you mount the Fiber CAP L on a flat surface, follow the steps in
 - "Ground the Fiber CAP L (Optional)" on page 55 (if grounding is required or preferred)
 - "Connect the Passive RF Antenna" on page 59.

Mounting Two CAP Ls with a Dual Mounting Kit

Figure 11 shows the Dual Mounting Kit (CommScope PN 7815440-xx). The Dual Mounting Kit is capable of mounting two CAP Ls with or without fan kits.

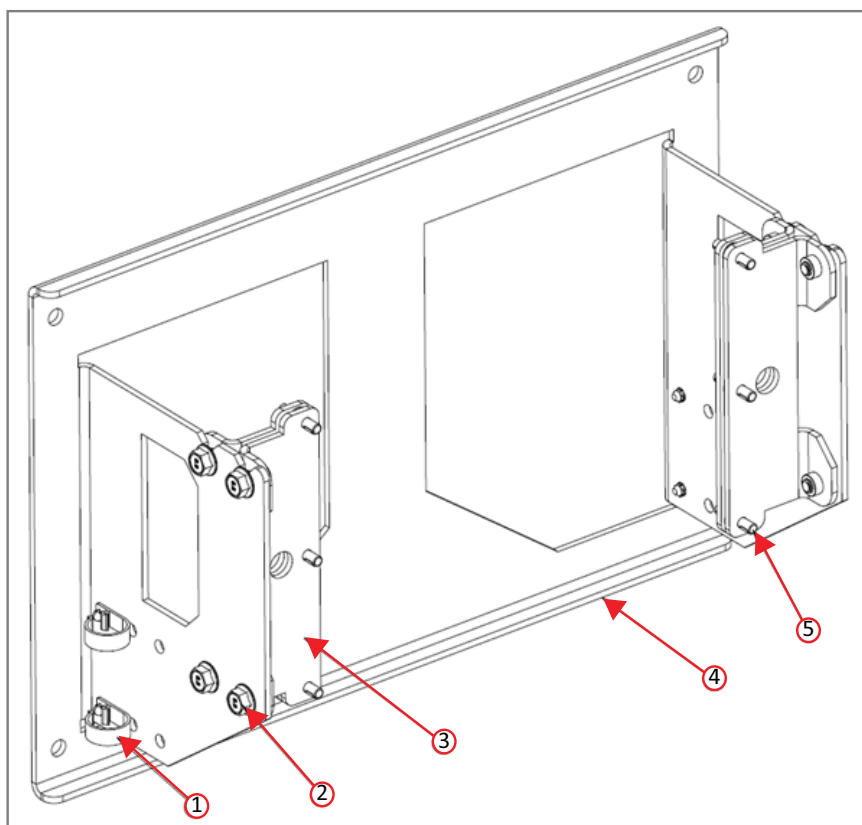

Ref #	Quantity	Component
1	4	Nylon Cable Clamps (preattached, do not remove)
2	8	M8x16 screws
3	4	Mounting Adapters
4	1	Dual Wall Mount Bracket
5	12	M6-1.0 x14mm screws

Figure 11. Dual Mounting Kit (PN 7815440-xx)

In this procedure you will mount two Fiber CAP Ls back-to-back in a single mounting bracket. The steps in this procedure will identify the two CAP Ls as CAP L-1 and CAP L-2, as shown in [Figure 12](#).

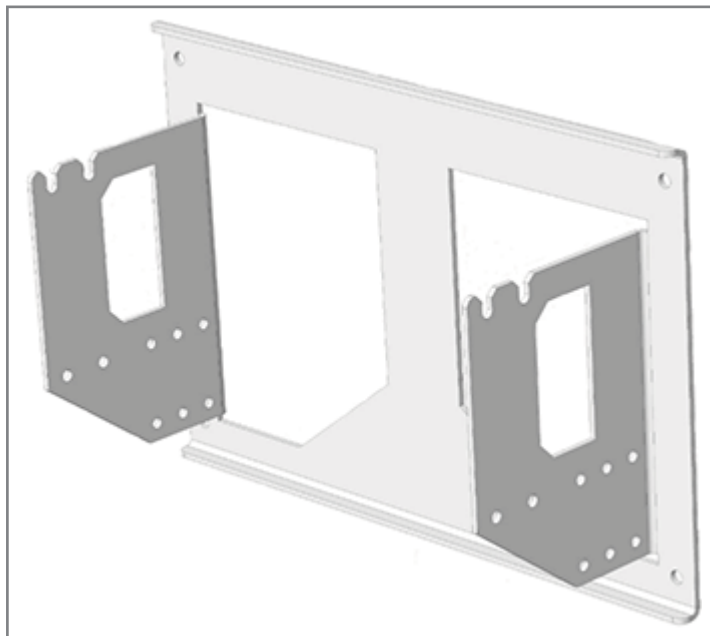

Figure 12. Two CAP Ls Back-to-Back in a Dual Mounting Bracket

Do the following to mount two Fiber CAP Ls in a Dual Mounting Bracket.

- 1 Use "[Plan and Prepare for a Fiber CAP L Installation](#)" on page 10 to identify the installation site and installation requirements, and to prepare for the installation.
- 2 Refer to and observe all cautions listed in "[General Mounting Cautions](#)" on page 24.
- 3 Refer to "[Determine the CAP L Installation Site](#)" on page 17 to determine the mounting location, which must be able to support the weight and dimensions of the CAP L.
- 4 Refer to "[Mounting Orientation for Wall Mounts](#)" on page 29 to determine the mounting orientation of the CAP L.

- 5 Secure the Dual Wall Mount Bracket (shown below) to the wall (or other suitable vertical surface), as described below.



- a Install the Dual Wall Mount Bracket using 4 M8 (or 5/16") screw anchors (not included) or suitable lag bolts according to the drilling layout, as shown below.



The M6 screw anchors do not ship with the CAP L as the anchor type is dependent on the on-site conditions (wall structure and materials). Use screw anchors that are rated for the mounting surface.

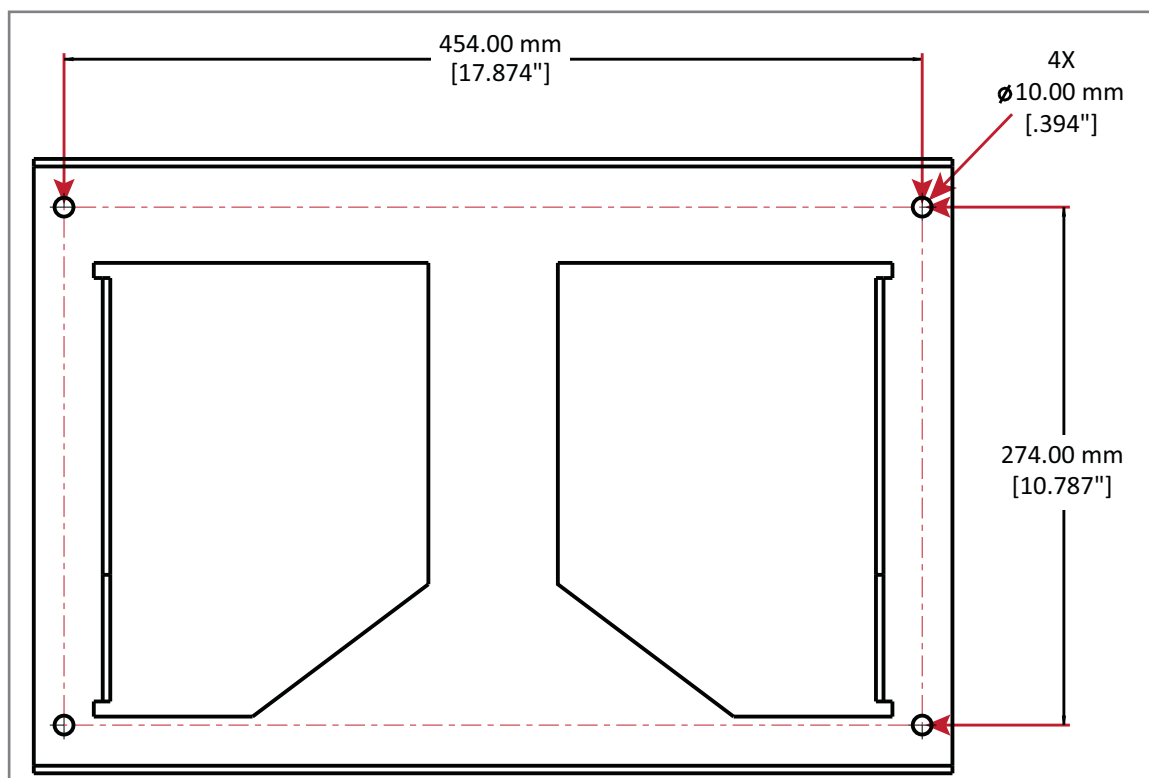

- b Confirm that the Dual Wall Mount Bracket is securely fastened to the wall.

- 6 Use the six M6-1.0 x14mm screws that came with the Dual Mounting Bracket Kit to attach the two Mounting Adapters (three screws per bracket) to the vertical M6-1.0 mounting taps on the back of the CAP L-1 chassis (three taps per side).

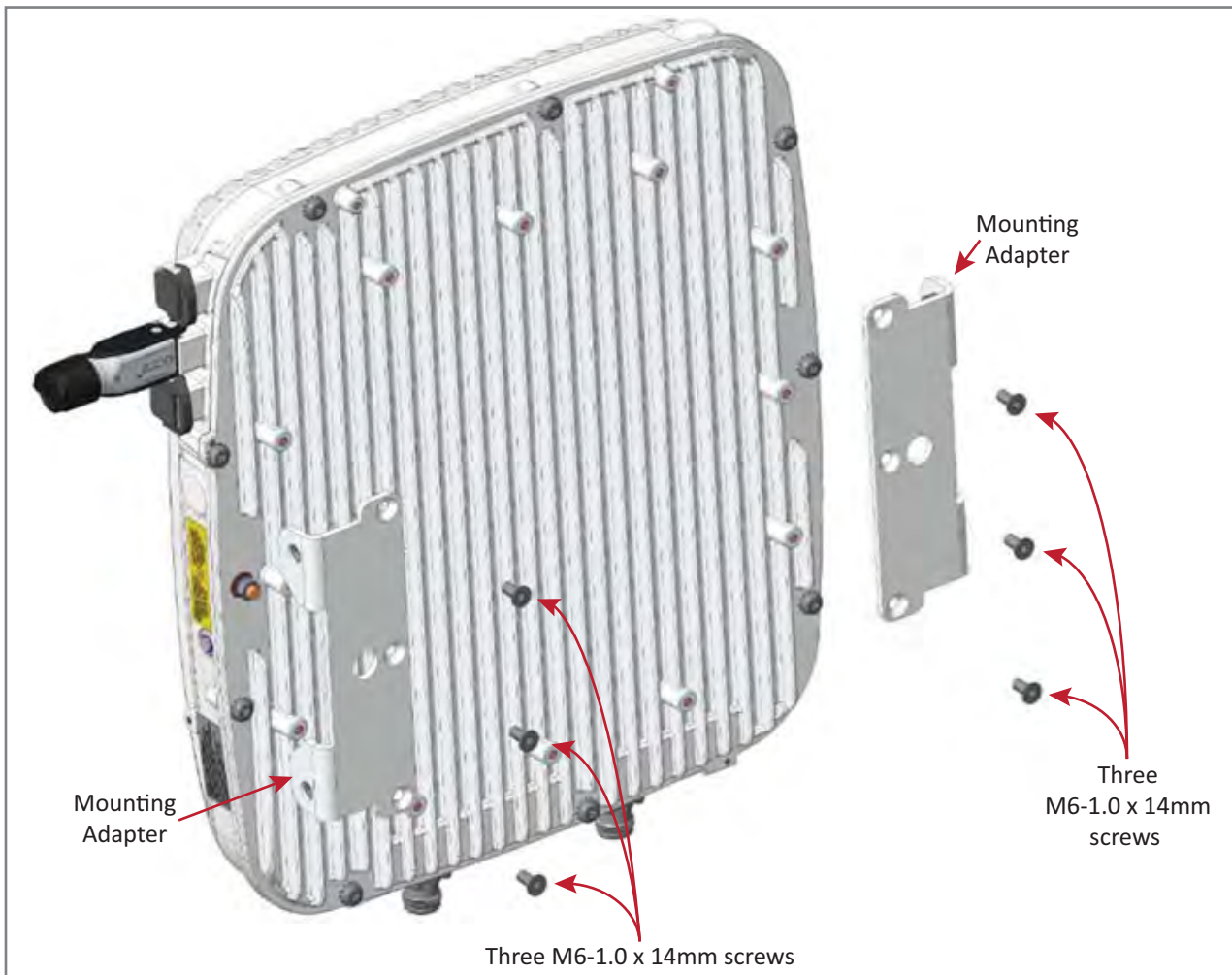

- 7 Insert an M8x16 screw in the top screw hole on the left Mounting Adapter attached to CAP L-1, and then insert screw three or four turns.

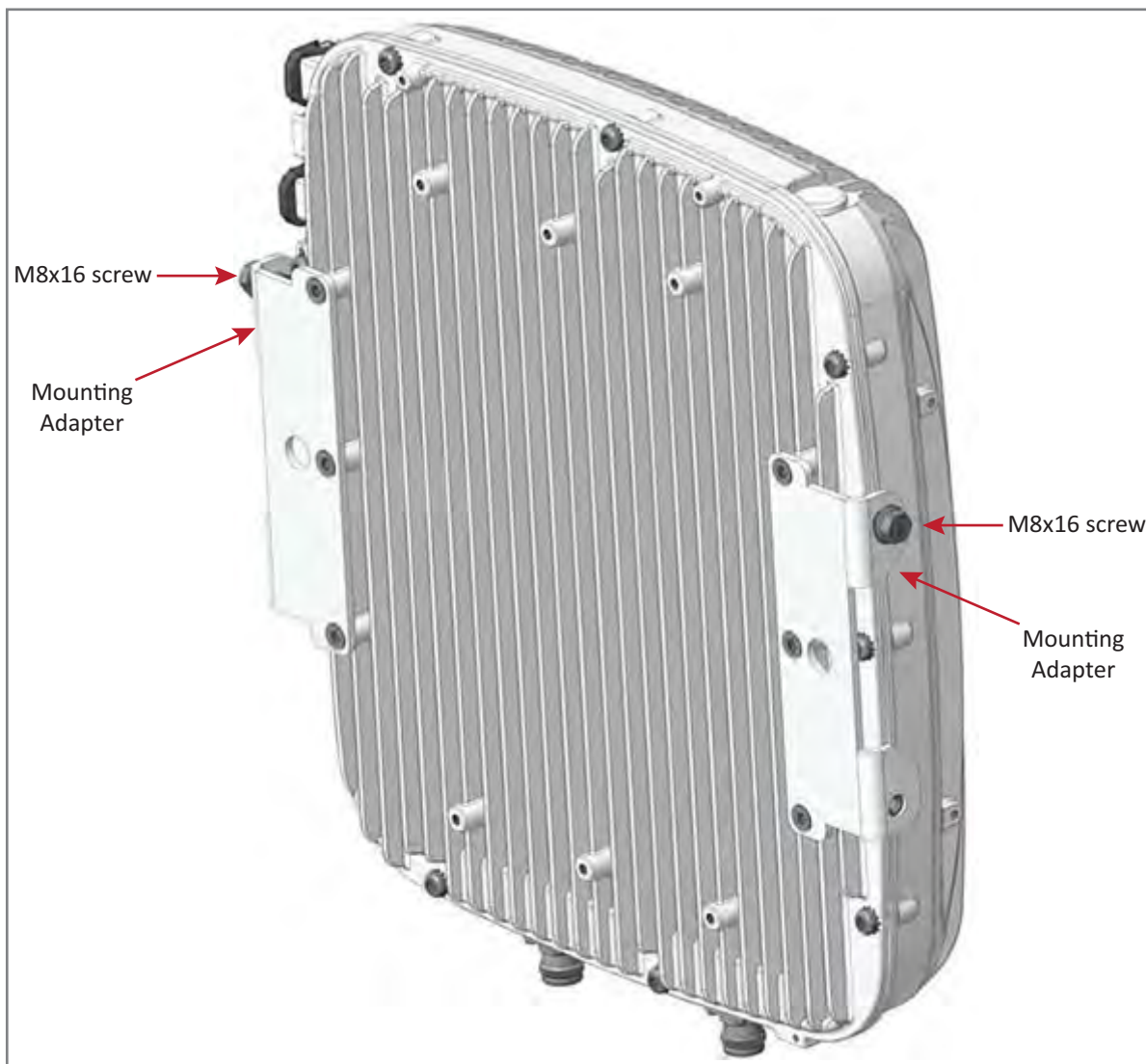

- 8 Repeat [Step 7](#) for the right Mounting Adapter.

- 9 Do the following to mount CAP L-1 in the Wall Bracket.
 - a Holding the CAP L-1 with the front of the chassis facing the mounting surface, lift it above the Mounting Bracket attached to the wall, and then lower it into place, aligning the M8x16 screws that you attached to the Mounting Adapters in [Step 7 on page 35](#) and [Step 8 on page 35](#) with the Mounting Bracket slots that are closest to the mounting surface.
 - b Insert an M8x16 screw into the bottom screw hole of the Dual Wall Mount Bracket that is closest to the mounting surface and into the bottom screw hole on each CAP L-1 Mounting Adapter.
 - c Tighten all four M8x16 screws to secure the CAP L-1 to the Dual Wall Mount Bracket; torque to 13.5 N-m (120 in-lb).

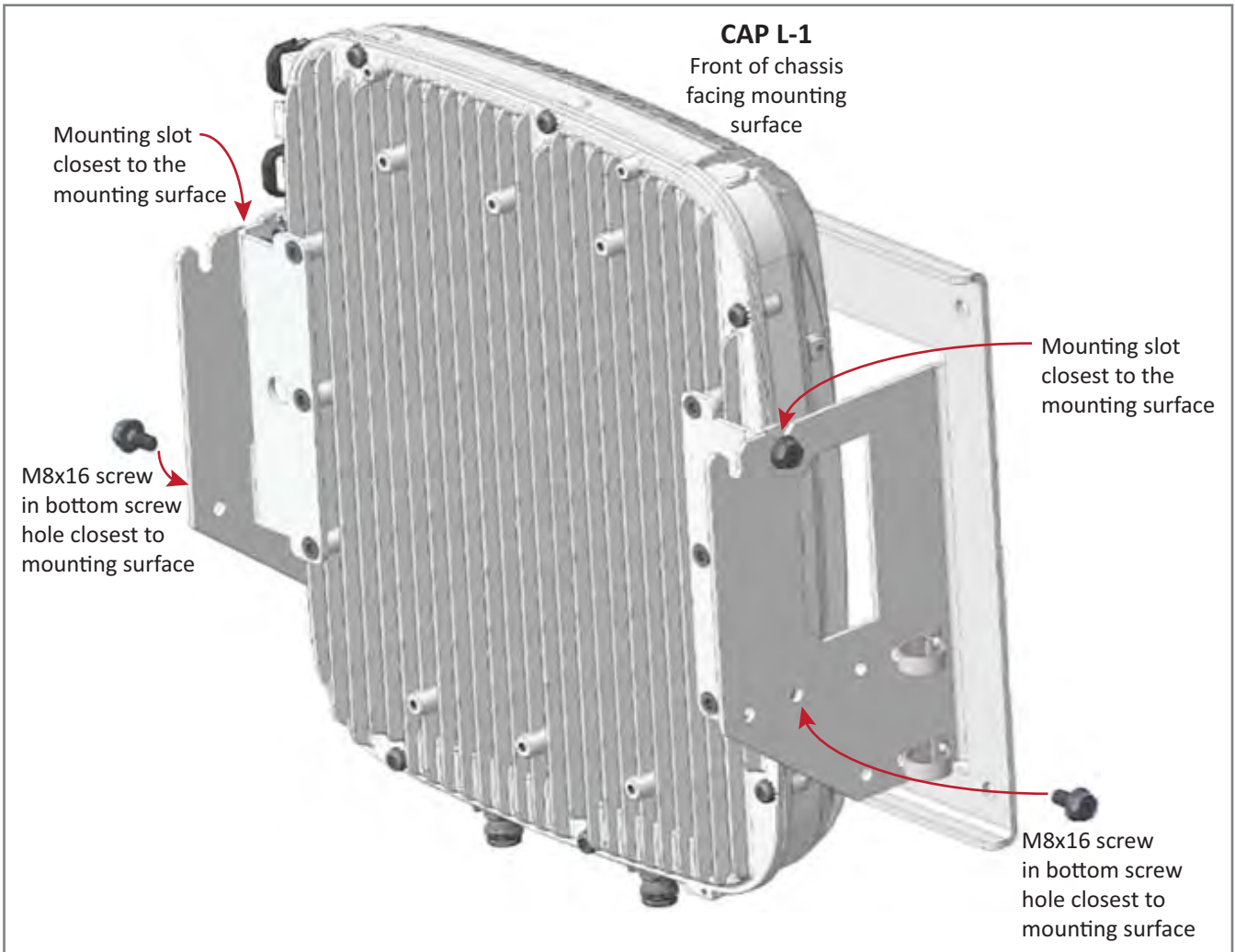

- d Confirm that the CAP L-1 is securely attached to the Dual Wall Mount Bracket, as shown in the following graphic.



- 10 Repeat [Step 6 on page 34](#) through [Step 9 on page 36](#) to mount the CAP L-2 chassis in the Dual Wall Mounting Bracket; install the CAP L-2 chassis back-to-back with the CAP L-1 chassis, as shown [Figure 12 on page 32](#).
- 11 After you mount the two CAP Ls in a Dual Mounting bracket, follow the steps in
- ["Ground the Fiber CAP L \(Optional\)" on page 55](#) (if grounding is required or preferred)
 - ["Connect the Passive RF Antenna" on page 59](#).

Mounting a CAP L with an AC/DC Power Supply Kit

An AC/DC Power Supply Kit provides a 48V External Power Supply that converts local AC power to DC power for the CAP L. An AC/DC Power Supply Kit can be used for a Fiber or Copper Interface when an AC power source is located near the CAP L.



Figure 13. CAP L with AC/DC Power Supply Kit

Do the following to mount a CAP L using an AC/DC Power Supply Kit.

- 1 Obtain the AC/DC Power Supply Kit that is appropriate for this installation. [Figure 14 on page 39](#) lists the three AC/DC Power Supply Kit part numbers; see also ["CommScope Part Numbers" on page 3](#).
- 2 Refer to and observe all cautions listed in ["General Mounting Cautions" on page 24](#).
- 3 Refer to ["Determine the CAP L Installation Site" on page 17](#) to determine the mounting location, which must be able to support the weight and dimensions of the CAP L.
- 4 Refer to ["Mounting Orientation for Wall Mounts" on page 29](#) to determine the mounting orientation of the CAP L.
- 5 Follow the steps in ["Unpack and Inspect the CAP L and Optional Accessories" on page 23](#).

Wiring the AC/DC Power Supply Kit.

The CommScope Local AC Power Supply Kits are available in three configurations as shown in ["CommScope Local AC/DC Power Supply Kits" on page 39](#). The installer must supply and install the AC input power cord for kit number 7775087-xx and kit number 7809823-xx. The AC input power cord for kit number 7809798-xx is connected internally but is unterminated at the customer end.

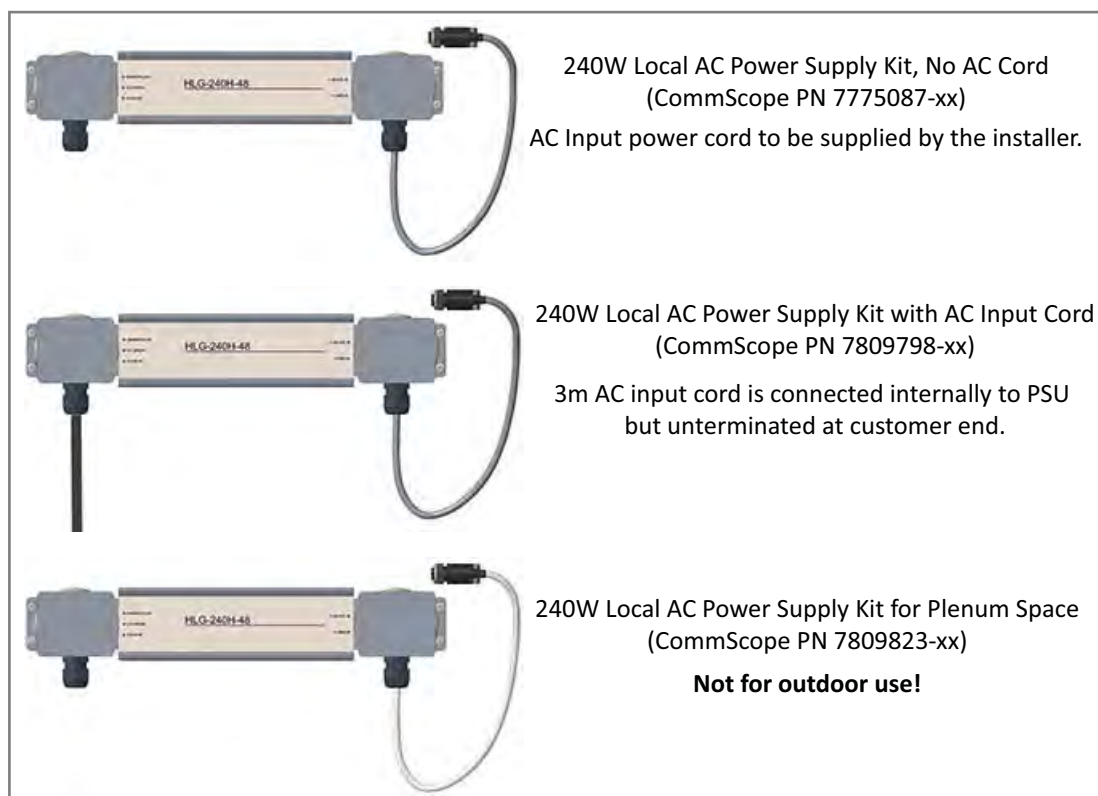

Figure 14. CommScope Local AC/DC Power Supply Kits

To insert and connect the AC input cord for kit number 7775087-xx and kit number 7809823-xx, do the following:

- 1 Remove the four Phillips head screws from the left junction box cover of the kit and then remove the junction box cover.

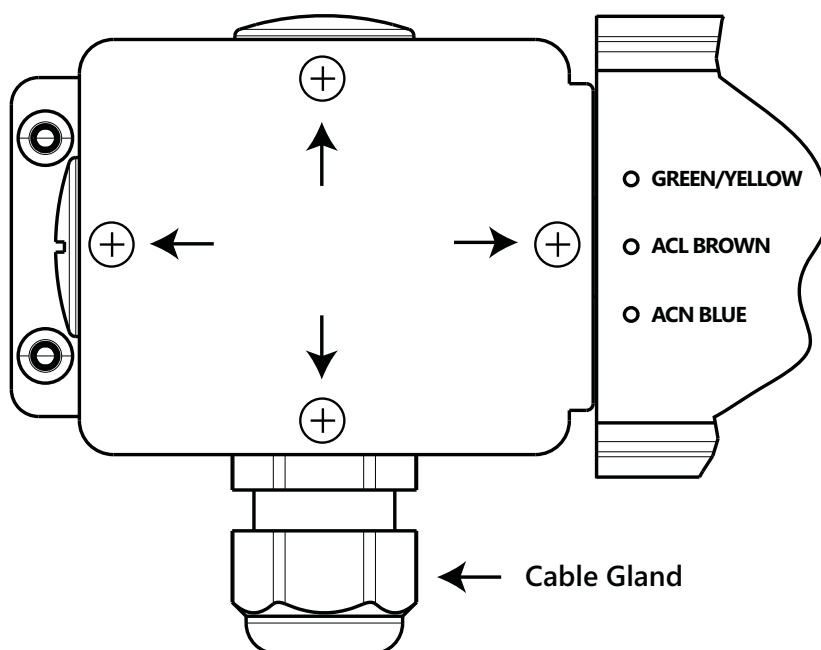

Figure 15. AC/DC Supply Junction Box Cover Screws

- 2 Insert a 16 AWG (1.31 mm²) 3-conductor AC input cable through the cable gland in the junction box.



A plenum rated AC input cable is required when using the Plenum AC Power Supply kit or else the cable must be routed to the junction box in conduit.

- 3 Terminate the cables using WAGO 221 Series Lever-Nuts or equivalent connectors as shown in [Figure 16](#).

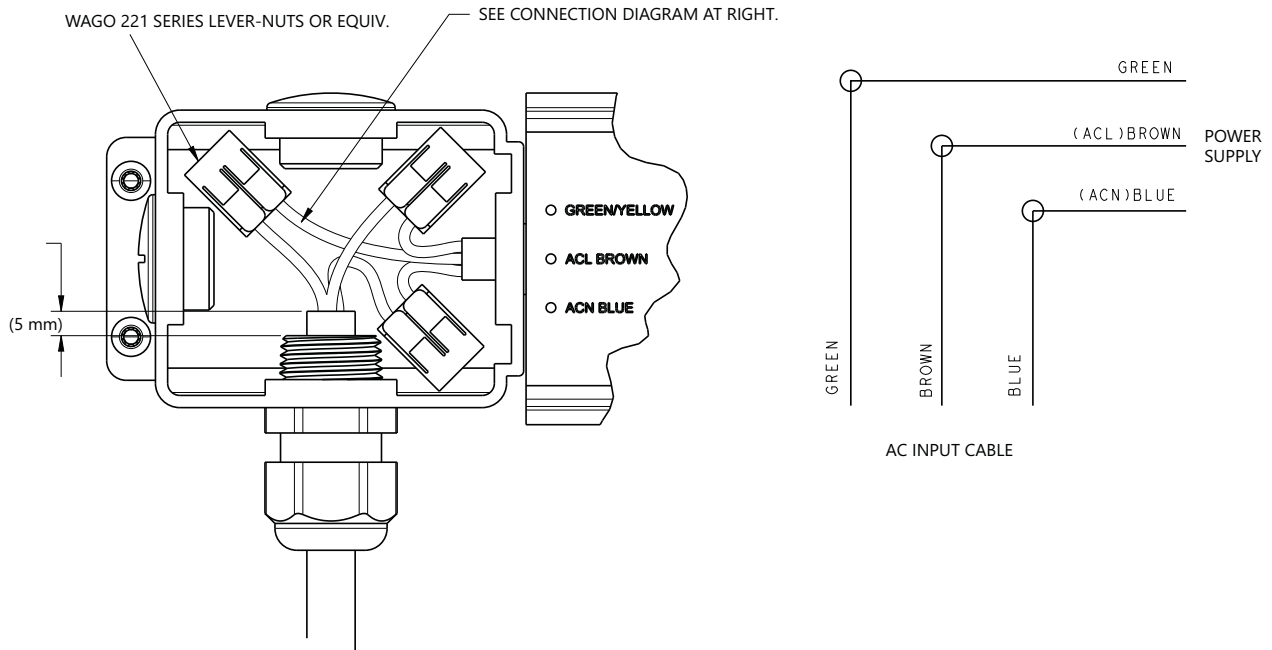

Figure 16. AC/DC Supply Cable Terminations

- 4 Torque the cable gland nut to 3.0 Nm (26.5 in-lb) to secure the cable.
- 5 Replace the junction box cover and tighten the four Phillips head screws to secure it.
- 6 Mount the AC/DC Power Supply Kit to the CAP L mounting bracket.



Due to derating requirements, each CAP L must have its own PSU – no sharing is permitted.

- 7 Assemble and mount the AC/DC Power Supply Kit and the CAP L, as described below and as shown in [Figure 17 on page 41](#) (CAP L without Fan Kit) and [Figure 18 on page 42](#) (CAP L with Fan Kit). The Local Power Jumper Cable Assembly will be connected to the AC/DC Power Supply Junction Box at the factory.
 - a Use the four screws to attach the AC/DC Power Supply assembly to the Wall Mounting Bracket.
 - b Attach the assembled AC/DC Power Supply Kit and Wall Mounting Bracket to the selected mounting location.
 - c Use the six M6-1.0 x14mm screws to attach the two Angled Mounting Brackets to the Wall Mounting Bracket.
 - i Put the top two flange-head screws halfway into the mounting brackets, and then use them to “hang” the CAP L in the Wall Mounting Bracket.
 - ii Attach the bottom two flange-head screws.
 - iii Tighten all four screws.

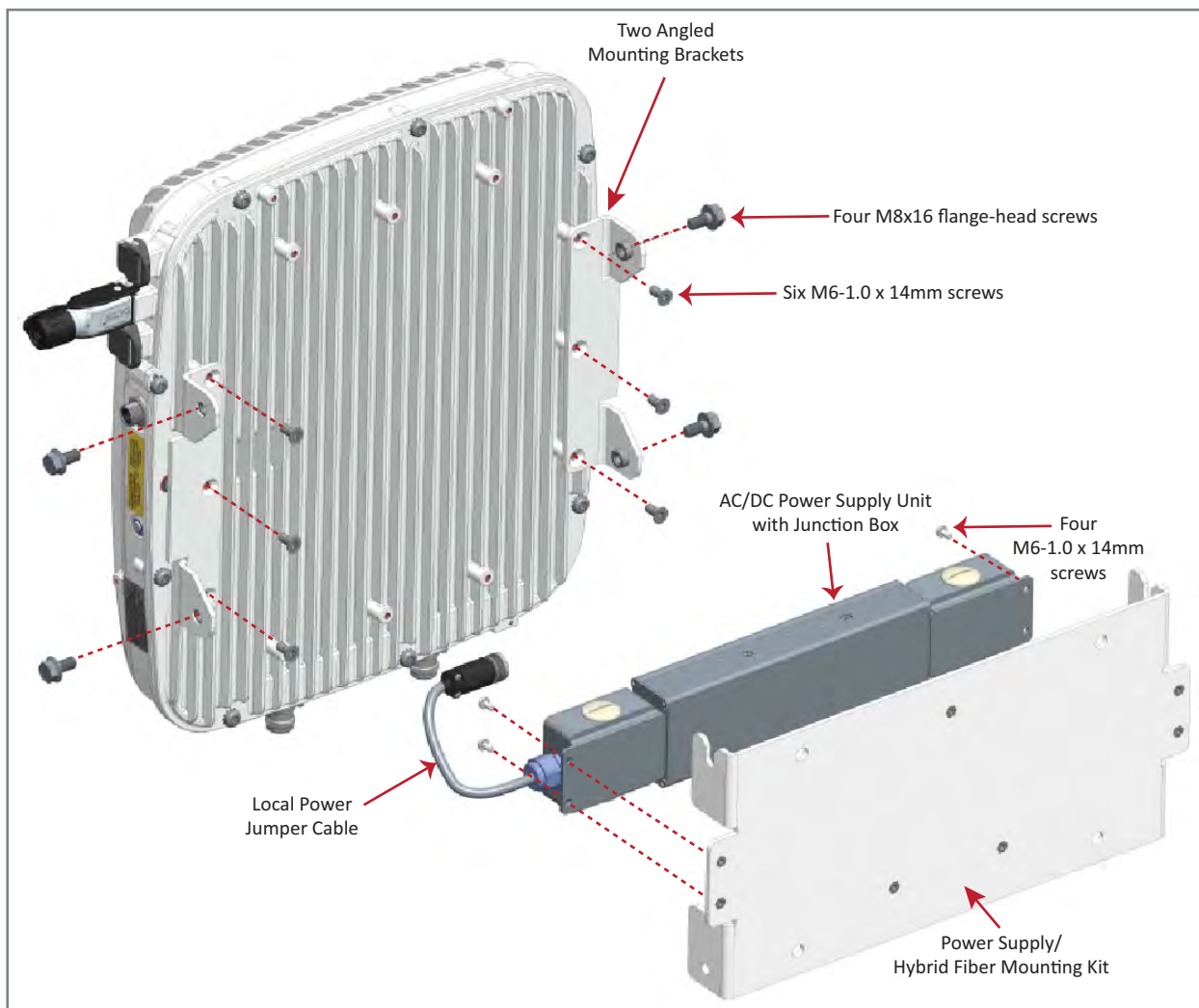

Figure 17. CAP L (No Fan Kit) with AC/DC Power Supply Kit (PN 7775087-xx) and Power Supply/Hybrid Fiber Mounting Kit (7774354-xx)

The Power Supply/Hybrid Fiber Mounting Kit is not included with the CAP L and must be ordered separately.

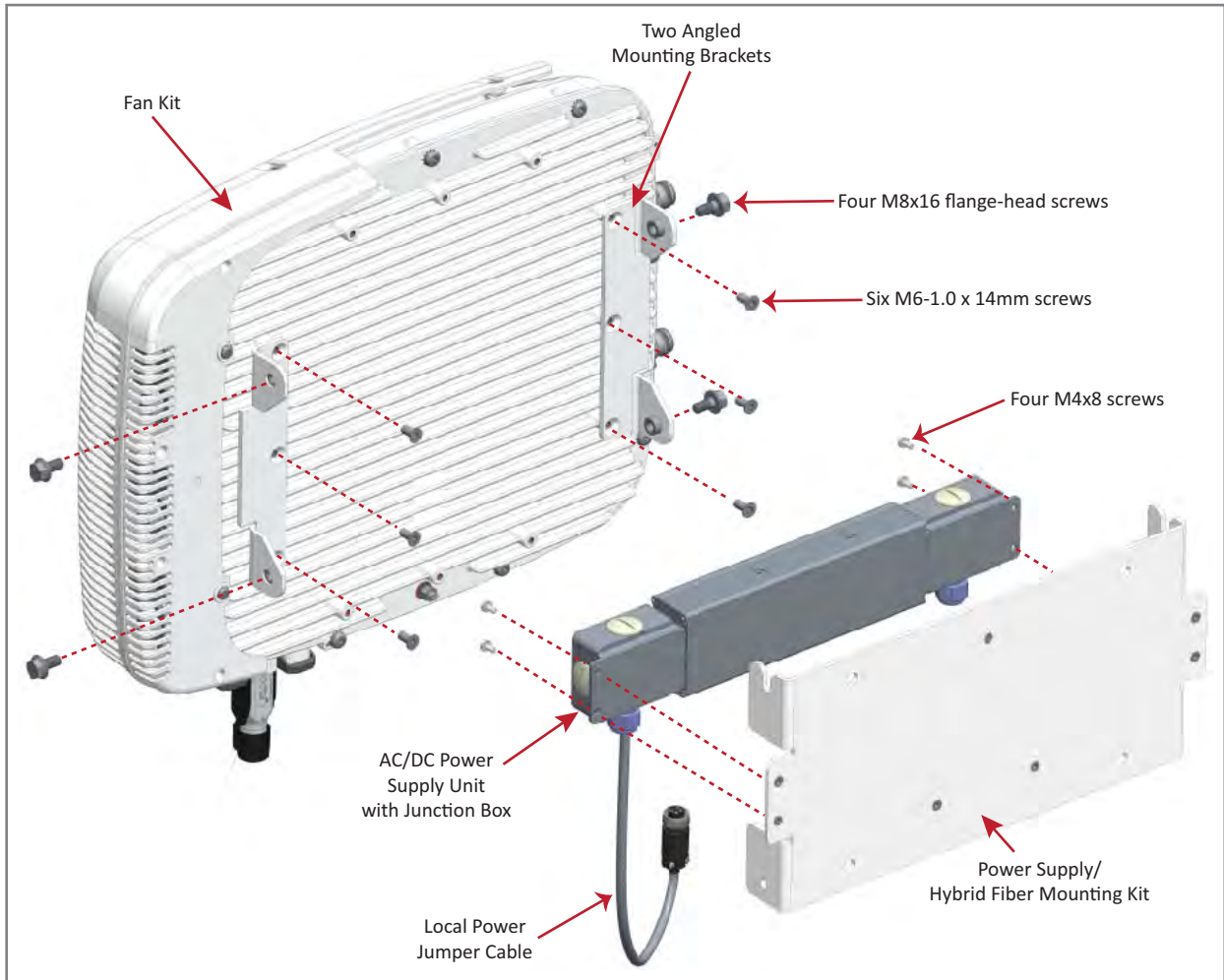
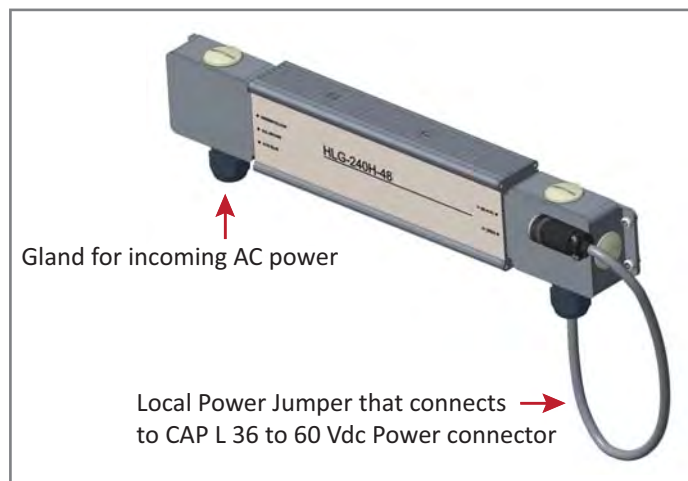

Figure 18. CAP L with Fan Kit, AC/DC Power Supply Kit (PN 7775087-xx) and Power Supply/Hybrid Fiber Mounting Kit (PN 7774354-xx)

- 8 Connect the Local Power Jumper Cable (shown below) to the CAP L 36 to 60 Vdc Power connector (see [Figure 2 on page 6](#)).



- 9 Follow the steps in "[Ground the Fiber CAP L \(Optional\)](#)" on [page 55](#) if grounding is required or preferred.
- 10 Follow the steps in "[Connect the Passive RF Antenna](#)" on [page 59](#).

Mounting a CAP L with a Hybrid Fiber Splice Box Kit

The CAP L Hybrid Fiber Splice Box Kit (CommScope PN 7781091-xx) provides a connection solution for both power and optical signals to a CAP L. For Fiber CAP Ls, you have the option to use composite cable to transport signals from a TEN or Classic CAN via fiber and power from a remote DC supply, and then use the CAP L Hybrid Fiber Splice Box Kit to terminate the power and fiber at the CAP L.



The CAP L is designed to be supplied by two LPS (Limited Power Source, <100VA) circuits. By using LPS circuits, some electrical code requirements for installing the power cables are relaxed. The CAP L supports a combined/parallel circuit approach. That is, two LPS circuits can be combined in parallel and the CAP L supplied by a single, higher power source. In either configuration, all electrical and safety code requirements must be followed.



It is the responsibility of the customer/installer to observe the local regulations of the DC service provider and to comply with Limited Power Source (LPS) requirements where applicable.

Prepare for CAP L Hybrid Fiber Splice Box Kit Installation

- 1 Follow the steps in ["Unpack and Inspect the CAP L and Optional Accessories"](#) on page 23.
- 2 Refer to ["Determine the CAP L Installation Site"](#) on page 17 to determine the mounting location, which must be able to support the weight and dimensions of the CAP L.
- 3 Refer to ["Mounting Orientation for Wall Mounts"](#) on page 29 to determine the mounting orientation of the CAP L.

Assembling and Wiring the Hybrid Fiber Splice Box

The following subsections describe how to assemble the Hybrid Fiber Splice Box and then how to wire it to provide power to the CAP L:

- ["Assembling and Wiring the Hybrid Fiber Splice Box"](#) on page 43 tells you how to place the wires into the Hybrid Fiber Splice Box.
- You then need to follow one of the following procedures that meets the powering requirements of this installation.
 - ["Wire a Hybrid Fiber Splice Box for 4-Wire Power with Limited Power Source"](#) on page 47
 - ["Wire a Hybrid Fiber Splice Box for 2-Wire Power without Limited Power Source"](#) on page 49
 - ["Wire a Hybrid Fiber Splice Box to Cascade Two CAP Ls with the 2-Wire Power Configuration"](#) on page 50
 - ["Wire a Hybrid Fiber Splice Box to Cascade Two CAP Ls with the 4-Wire Power Configuration"](#) on page 51.

Wire the Hybrid Fiber Splice Box

Do the following to assemble and wire the Hybrid Fiber Splice Box.

- 1 Open the Hybrid Fiber Splice Box and remove the installation kit that is inside.



- 2 Using the parts from the Hybrid Fiber Splice Box, insert the Splice Holder and fasten it using a PTK 30x6 screw and one M4 washer.

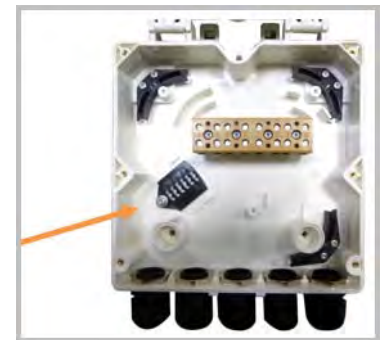

- 3 From the CAP L Hybrid Fiber Splice Box Kit, insert Fiber Patch Cord in one of the cable glands indicated in the graphic to the right.



- 4 Strip the insulation of the composite cable for 100 cm and the fibers for 90 cm, and then shorten the copper cables to 25 cm.

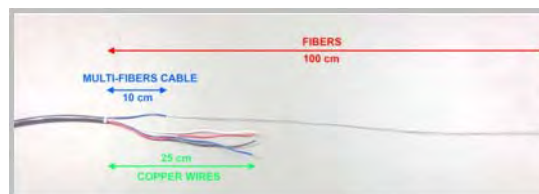

- 5 Insert the composite cable in the first cable gland and separate the multi-fibers cable from the copper wires. It is necessary to remove the nut to perform this action. The cable must be fed through the nut and it must be retightened once finished.



- 6 Bend the spliced fibers using the corner guides and fix the splices to the splice holder.

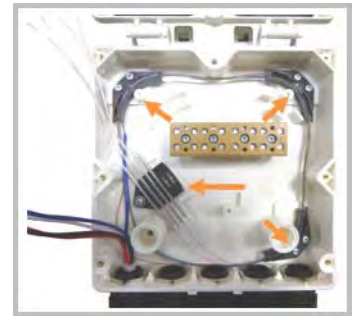

- 7 Bend the optical cables as shown in the picture to the right.



- 8 If a second splice holder is needed, it can be assembled using the M4 insulating washer and two M4 plain washers, as shown to the right. The required screw is a PTK30 x 12.



- 9 Remove the sealing nut and rubber of the cable gland and insert the optical cables.



10 Place each cable into one of the grooves of the seal insert.



11 Press the seal insert into the clamp ring opening.



12 Fix the optical cables inside the box using one cable tie and tight the sealing nut.

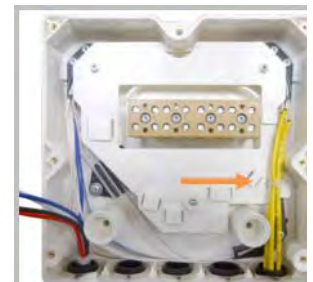

13 It is possible to separate the optical cables and use two different cable glands. Remove the sealing nut and rubber on each cable gland.



14 Close all unused grooves with the plastic cylinders, no matter if one or two cable glands are used.



15 Insert the copper wires in the first multiple terminal connectors. See markings on the internal support. Then fasten the copper cables inside the box using one cable tie.

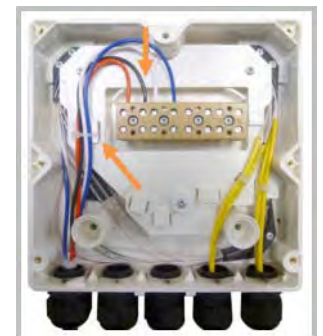

- 16** Remove the sealing nut and insert the CAP L supply cable and tighten the sealing nut.
- 17** Connect the supply cable to the terminal strip and fix it inside the box using one cable tie.

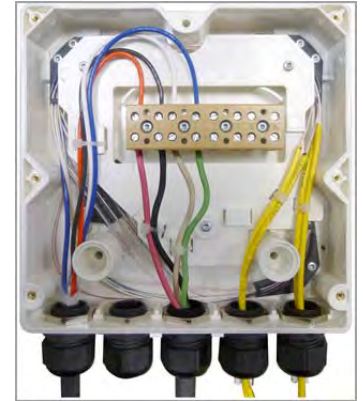

It is possible to connect a second supply cable to cascade two CAP Ls, as shown in the graphic to the right.

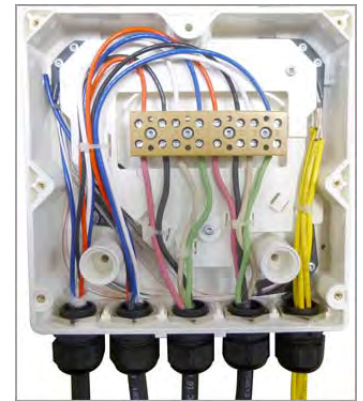

- 18** Complete the steps in "[Wall Mount a CAP L Using a CAP L Hybrid Fiber Splice Box Kit](#)" on page 52.

Wire a Hybrid Fiber Splice Box for 4-Wire Power with Limited Power Source

Use the 4-wire power setup when Limited Power Source (LPS) is required by local electrical/safety codes. Each CAP L can accept two Limited Power Sources from the DC PSU where local regulations require it.

In the following wiring procedure, you will connect the power wires from the Hybrid Fiber Splice Box to a DC Power Supply Unit (PSU).



The color code of the hybrid fiber cable in the following tables and diagrams is for example purposes only. The color of the wires may be different than the examples depending on the type and manufacturer of the composite hybrid cable.

- 1 Refer to [Table 10](#) and [Figure 19](#) to wire a Hybrid Fiber Splice Box for 4-Wire power with Limited Power Source (LPS).



All four pins of the proprietary CAP L 4-pin 36 to 60 Vdc Power connector must be terminated.

Table 10. 4-Wire Power Wiring with LPS

Hybrid Cable Two Circuits	CAP L Power Cable		
	Wire	Pin	Function
Circuit 1 (0V)	Red	1	V1+
Circuit 1 (-36 to -60V)	Black	2	V1-
Circuit 2 (0V)	White	3	V2+
Circuit 2 (-36 to -60V)	Green	4	V2-

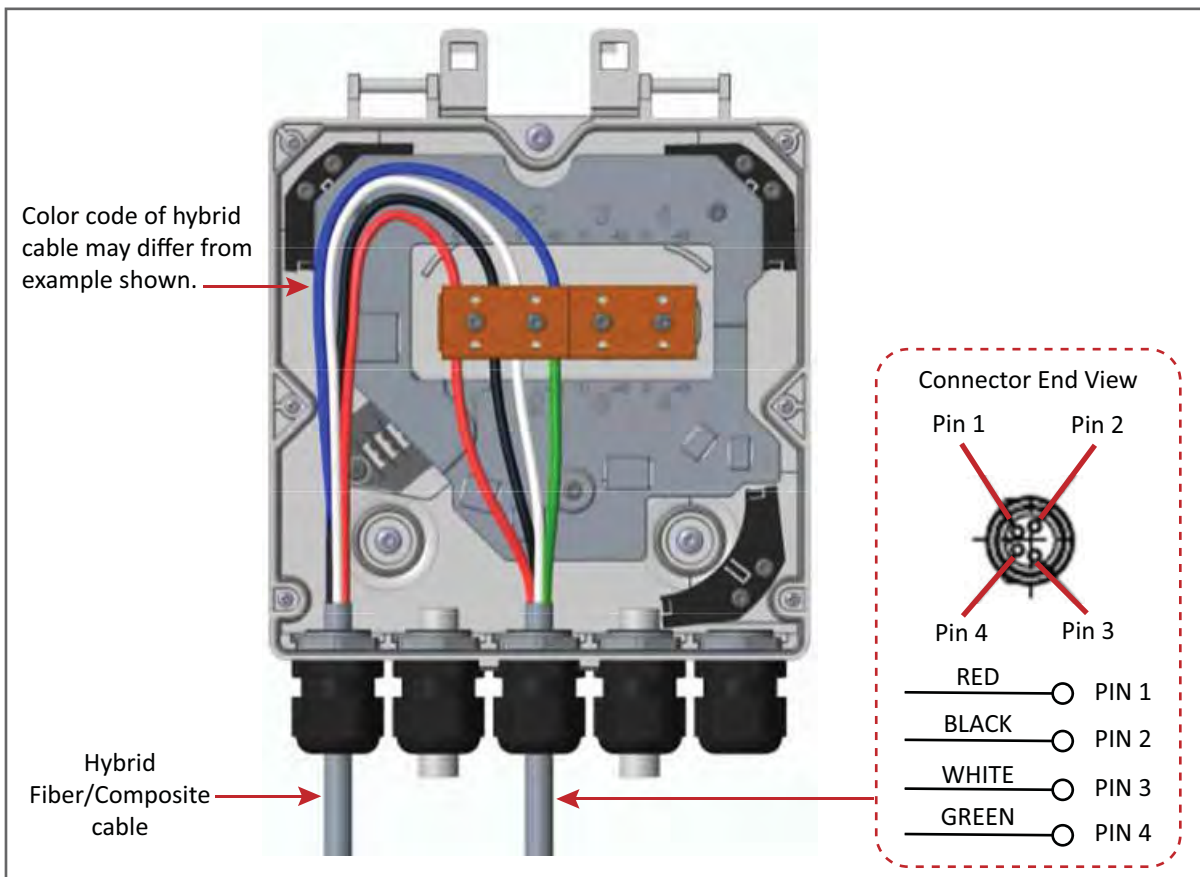

Figure 19. Wiring a Hybrid Fiber Splice Box for 4-Wire Power with LPS

- 2 After you have wired the Hybrid Fiber Splice box, complete the steps in "[Wall Mount a CAP L Using a CAP L Hybrid Fiber Splice Box Kit](#)" on page 52.

Wire a Hybrid Fiber Splice Box for 2-Wire Power without Limited Power Source

Each CAP L can be powered by 2 wires if LPS from the DC PSU are not required by local regulations..



All four pins of the proprietary CAP L 4-pin 36 to 60 Vdc Power connector must be terminated.

- 1 Refer to [Table 11](#) and [Figure 20](#) to wire a Hybrid Fiber Splice Box for 2-Wire power without an Limited Power Source (LPS).

In this power variation you must tie the following power cables together:

- **V1+ (PIN 1)** and **V2+ (PIN 3)** (CAP L DC Jumper Power Cable Red and White wires)
- **V1- (PIN 2)** and **V2- (PIN 4)** (CAP L DC Jumper Power Cable Black and Green wires)

Table 11. Wiring Single Circuit Source to a CAP L

Source Cable	CAP L Power Cable		
	Wire	Pin	Function
Circuit 1 (0V)	Red	1	V1+
	White	3	V2+
Circuit 1 (-36 to -60V)	Black	2	V1-
	Green	4	V2-

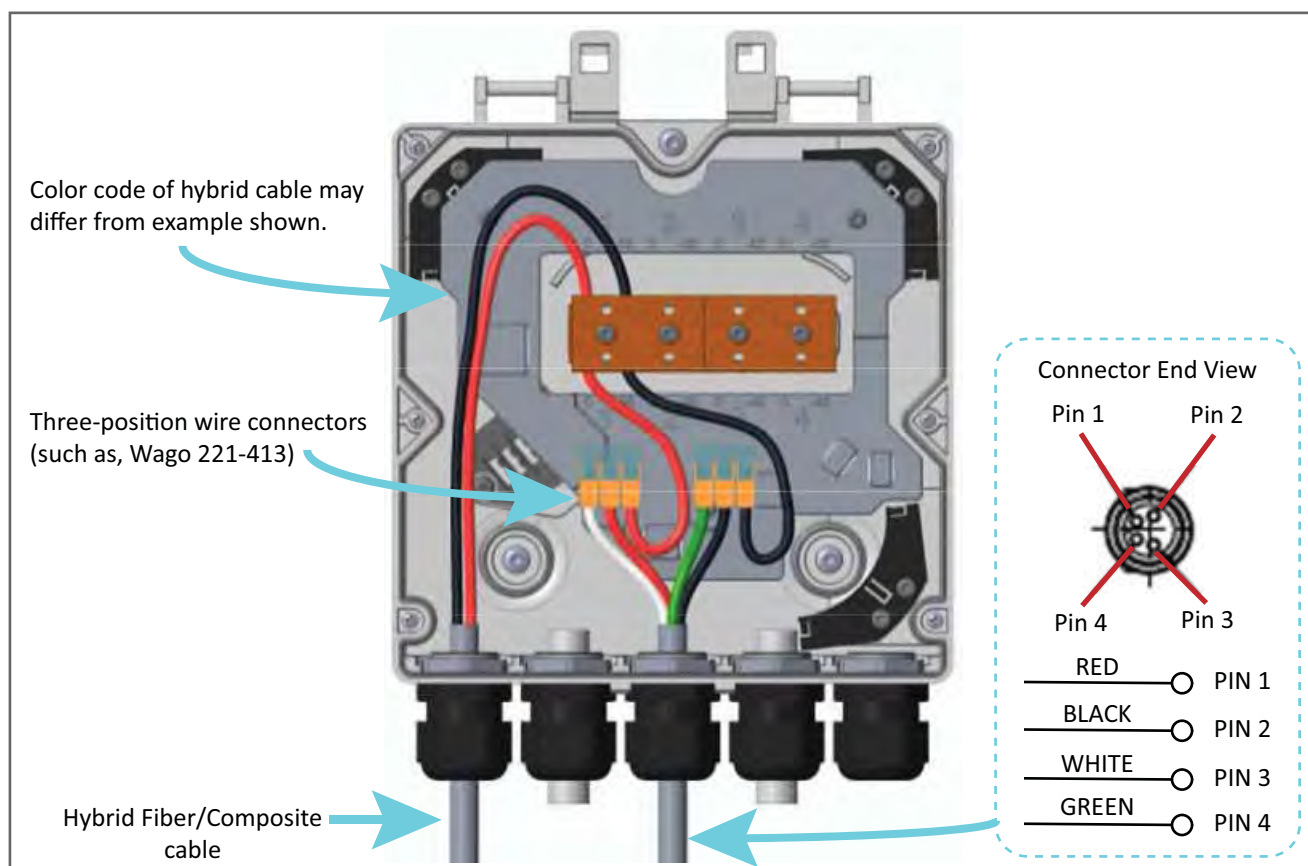

Figure 20. Wiring a Hybrid Fiber Splice Box for 2-Wire Power without LPS

- 2 After you have wired the Hybrid Fiber Splice box, complete the steps in "Wall Mount a CAP L Using a CAP L Hybrid Fiber Splice Box Kit" on page 52.

Wire a Hybrid Fiber Splice Box to Cascade Two CAP Ls with the 2-Wire Power Configuration

Figure 21 shows a variation of the 2-Wire power configuration that allows you to cascade two CAP Ls using a single 4-wire hybrid cable.



All four pins of the proprietary CAP L 4-pin 36 to 60 Vdc Power connector must be terminated.



Figure 21. Wiring a Hybrid Fiber Splice Box to Cascade Two CAP Ls in a 2-Wire Power Configuration

Wire a Hybrid Fiber Splice Box to Cascade Two CAP Ls with the 4-Wire Power Configuration

Figure 22 shows a variation of the 4-Wire power configuration that allows you to cascade two CAP Ls using two 4-wire hybrid cables.



All four pins of the proprietary CAP L 4-pin 36 to 60 Vdc Power connector must be terminated.

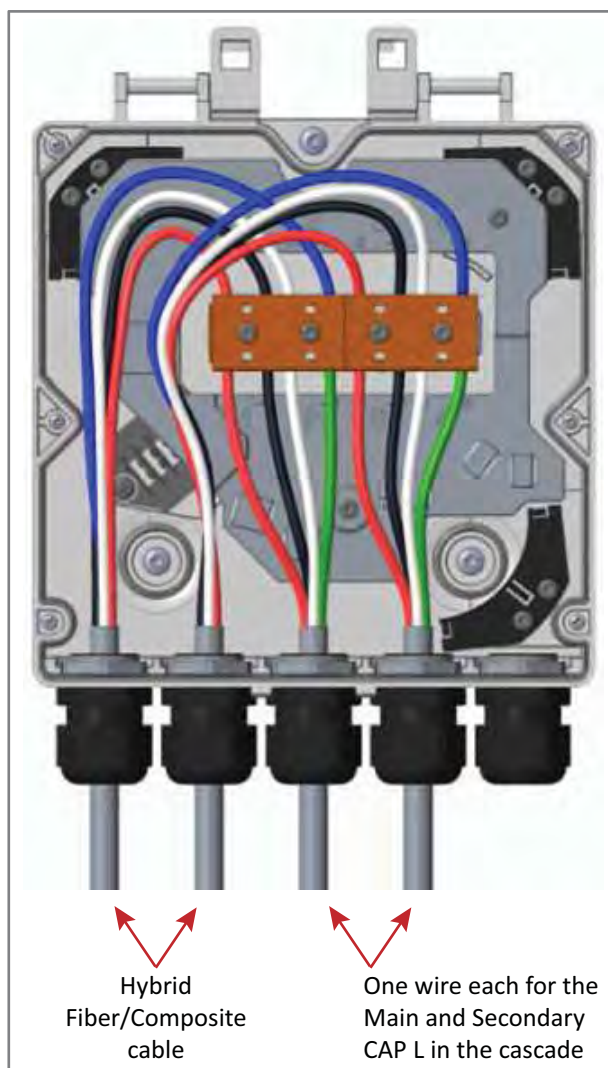
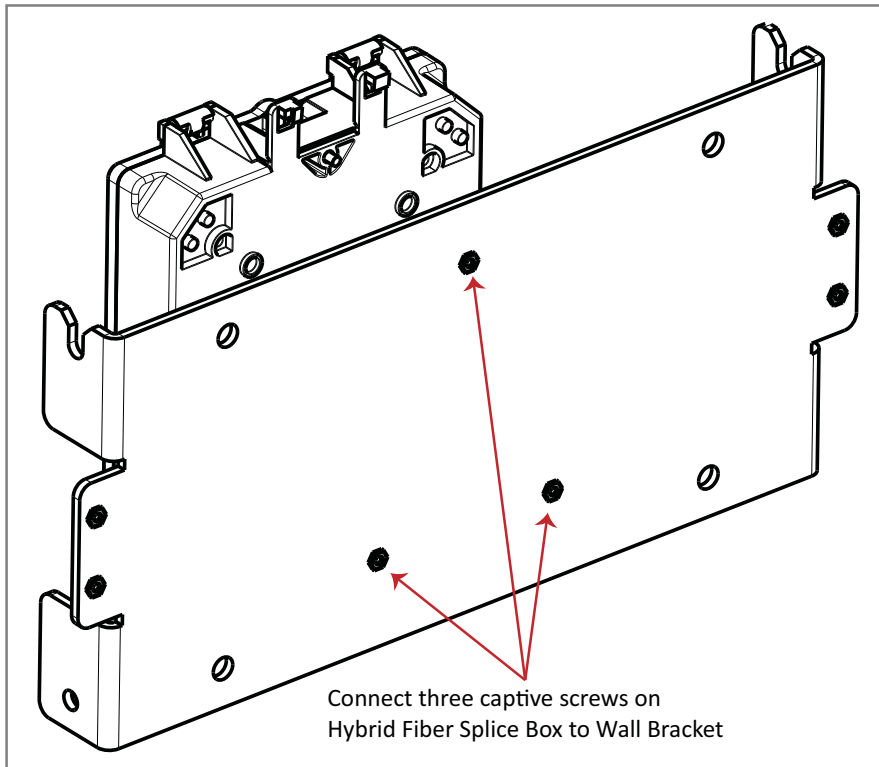

Figure 22. Wiring a Hybrid Fiber Splice Box to Cascade Two CAP Ls in a 4-Wire Power Configuration

Wall Mount a CAP L Using a CAP L Hybrid Fiber Splice Box Kit

- 1 Attach the Hybrid Fiber Splice Box to the Wall Bracket with the three captive screws already installed in the Splice Box.



- 2 Attach the assembled Wall Mounting Bracket and Hybrid Splice Box to the selected mounting location.
- 3 Use the six M6-1.0 x14mm screws to attach the two Angled Mounting Brackets to the back of the CAP L, as shown below.

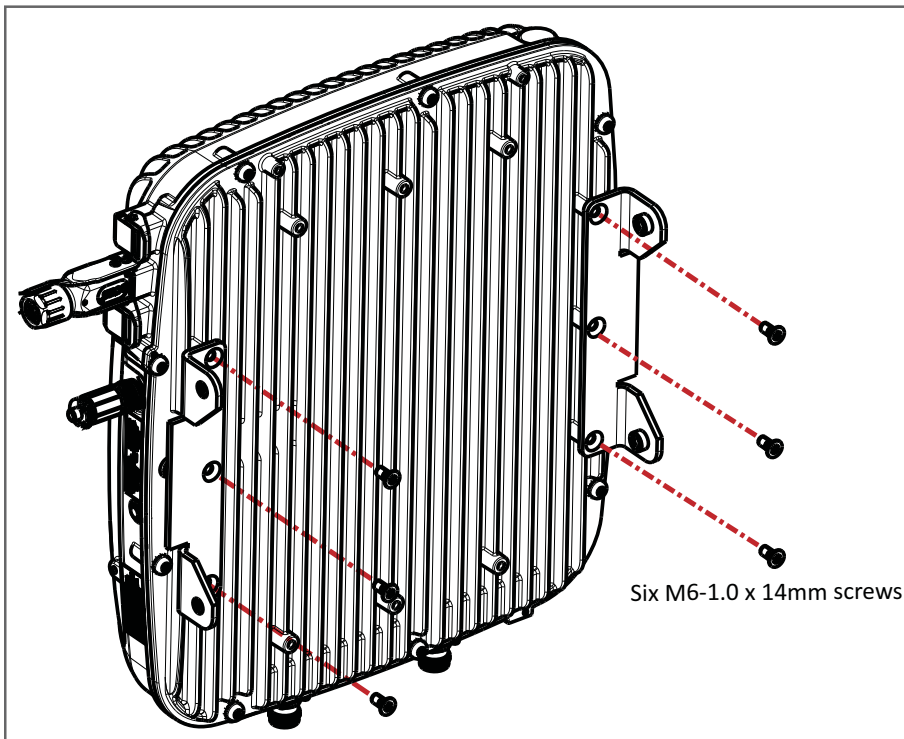

The following graphic provides an exploded view of how the different components of the Hybrid Splice Box Mounting Kit come together.

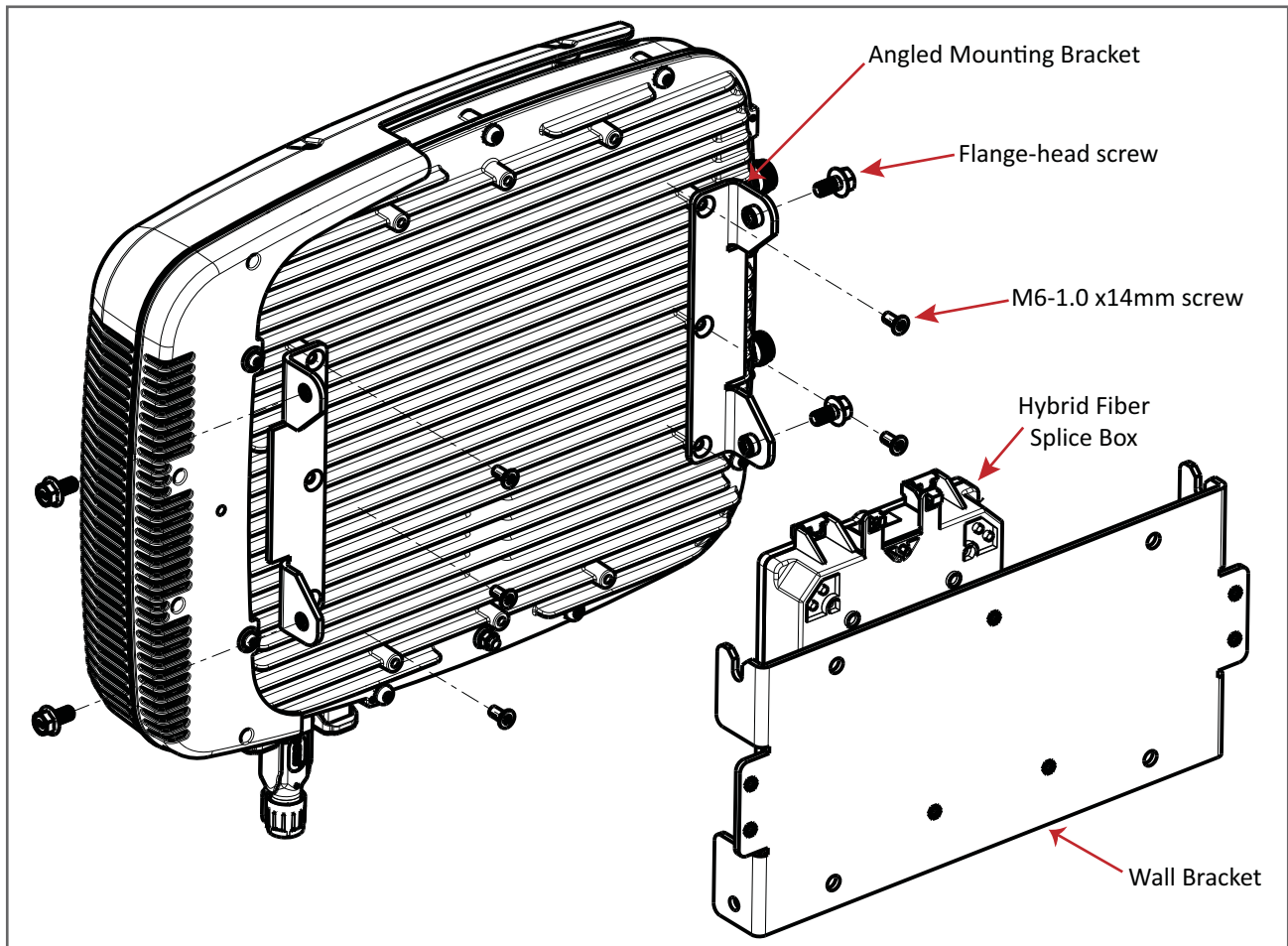

- 4 Put a flange-head screw halfway into the top screw holes on the side of the Angled Mounting Brackets.
- 5 Lift the CAP L so you can align the two flange-head screws with the mounting slots on the Wall Mounting Bracket, and then lower the CAP L so that it hangs on the Wall Mounting Bracket.
- 6 Attach the bottom two flange-head screws.
- 7 Tighten all four flange-head screws.
- 8 Attach the cables running from the bottom of the CAP L Hybrid Fiber Splice Box Kit.
 - a Attach the Local Power Jumper to the CAP L power connector.
 - b Attach the Fiber Patch Cord to the CAP L Port 1; the other end was attached in Step 4c ([page 44](#)) to one of the cable glands.
- 9 After you mount the CAP L with a CAP L Hybrid Fiber Splice Box Kit, follow the steps in
 - "[Ground the Fiber CAP L \(Optional\)](#)" on [page 55](#) (if grounding is required or preferred)
 - "[Connect the Passive RF Antenna](#)" on [page 59](#).

Ceiling Mount a CAP L

You can mount a CAP L above or below a ceiling. When installing a CAP L below a ceiling, the use of the optional Fan Kit determines how the CAP L can be ceiling mounted, as described in the following sections.

- ["Ceiling Mount a CAP L without a Fan Kit" on page 54](#)
- ["Ceiling Mount a CAP L with a Fan Kit" on page 54.](#)

If you mount the CAP L above the ceiling, its antennas must protrude below the ceiling.

Ceiling Mount a CAP L without a Fan Kit

A CAP L that does not have a Fan Kit should only be installed above a suspended ceiling on a flat surface, using the steps in ["Flat-Surface Mount a CAP L" on page 27.](#)

Ceiling Mount a CAP L with a Fan Kit

- 1 Follow the steps in ["Unpack and Inspect the CAP L and Optional Accessories" on page 23.](#)
- 2 Refer to and observe all cautions listed in ["General Mounting Cautions" on page 24.](#)
- 3 Refer to ["Determine the CAP L Installation Site" on page 17](#) to determine the mounting location, which must be able to support the weight and dimensions of the CAP L.
- 4 Follow the steps in one of the following sections that apply to securing the desired mounting bracket to the CAP L:
 - ["Wall Mount a CAP L Using a Flat Mounting Bracket Kit" on page 30](#)
 - ["Mounting a CAP L with an AC/DC Power Supply Kit" on page 38](#)
 - ["Mounting a CAP L with a Hybrid Fiber Splice Box Kit" on page 43](#)
- 5 Use four 5/16-inch or M8 lag screws (or whatever screw type is appropriate for the material to which the CAP L is to be mounted on) to mount the CAP L to the ceiling.
- 6 Follow the steps in ["Ground the Fiber CAP L \(Optional\)" on page 55](#) if grounding is required or preferred.
- 7 Follow the steps in ["Connect the Passive RF Antenna" on page 59.](#)

CONNECT THE CABLES TO THE FIBER CAP L

Complete the following procedures in the order in which they are presented. Unless otherwise noted, each procedure is applicable to a singular Fiber CAP L (not in a cascade), or to a Primary or Secondary CAP L in a cascade.

- "Ground the Fiber CAP L (Optional)" on page 55
- "Connect the Passive RF Antenna" on page 59
- "Connect the Fiber CAP L to a Classic CAN or TEN" on page 60
- "Cascade a Secondary Fiber CAP L (Optional)" on page 61
- "Connect an External Ethernet Device (Optional)" on page 62
- "Connect to Vdc Power" on page 62.



Do not remove protective caps from any of the connectors until instructed to do so.

Ground the Fiber CAP L (Optional)

Follow the steps below to ground the OPA only if grounding is required in your locality or if the installation plans require the CAP L be grounded. The different CAP L installation procedures will tell you when to ground the CAP L.



The CAP L is equipped with an M6 grounding stud located on the back of the unit; however, grounding is not necessary. CAP Ls are classified as low-voltage devices and do not have internal power supplies. CommScope recommends checking your local and national electrical codes to determine if grounding is a requirement.

Do the following to ground a Fiber CAP L.

- 1 Obtain a length of #18 AWG (1.00 mm) insulated stranded copper wire for use as a chassis-grounding wire.
- 2 Terminate one end of the wire with a ring terminal.
- 3 Locate the chassis-ground stud at the rear of the enclosure.
- 4 Remove the Keps nut from the chassis-ground stud.

- 5 Attach the ring end of the wire to the chassis ground stud, as shown in the graphic below.



- 6 Use the Keps nut removed in [Step 4](#) to secure the ground wire to the chassis-ground stud.
- 7 Route the free end of the chassis grounding wire to an approved (per local code or practice) earth ground source.

Connect the Fiber CAP L to a Passive RF Antenna

The following sections guide you through connecting the CAP M; complete these procedures in the order in which they are presented.

- ["Clean the RF Cable Connectors" on page 57](#)
- ["Connect the Passive RF Antenna" on page 59.](#)

Clean the RF Cable Connectors

This section tells you how to clean RF cable connectors. The graphics in this section illustrate the cleaning procedure and do not show the CAP M.



This procedure requires the use of compressed air. Wear protective clothing—especially protective glasses—to protect against injury from flying particles.



This procedure requires the use of flammable material. There is a risk of fire. Keep away from sources of ignition.



This procedure requires the use of eye irritant product. There is a risk of eye irritation. Avoid contact with eyes and skin. Wear protective clothing—especially protective glasses.

Do the following to clean the RF cable connectors.

1 Gather the following cleaning tools:

- Isopropyl alcohol
- Compressed air
- Lint-free wipe
- Cotton buds.



2 Remove the protective cap from the RF connector.



3 Use compressed air to remove metal chips and small particles from the mating and inner surfaces of the connector.



- 4 Use a lint-free wipe drenched with isopropyl alcohol to clean the connector winding.



- 5 Use a cotton bud drenched with isopropyl alcohol to clean the lip of the inner ring.



- 6 Use a cotton bud drenched with isopropyl alcohol to clean the inside surface of the inner ring.



- 7 Use a cotton bud drenched with isopropyl alcohol to clean the inside of the center conductor spring tines.



- 8 Remove the protective caps from the unit connector, and then clean it the same way that you cleaned the cable connector.



- 9 Use compressed air to remove metal chips and small particles from the mating and inner surfaces of the connector.



- 10 Use a lint-free wipe drenched with isopropyl alcohol to clean the winding area.



- 11 Use a cotton bud drenched with isopropyl alcohol to clean the inside mating surface of the inner ring.



- 12 Use a cotton bud drenched with isopropyl alcohol to clean the outside surface of the center pin.



Connect the Passive RF Antenna

The following information regarding antenna mapping and is relevant to all Fiber CAP Ls.

- For Non-MIMO bands, there is no channel mapping option for the transceiver/antenna port. The transceiver/antenna port relationship is fixed in hardware.
- For MIMO bands, the Era GUI maps MIMO channels according to their AP designation:
 - AP0 to antenna port ANT 1
 - AP1 to antenna port ANT 2.
- When using SISO channels on a CAP L that supports MIMO, the system will automatically balance the number of channels between the two antenna ports, where the first SISO channel is mapped to ANT 1, the second SISO channel is mapped to ANT 2, and so on.

Do the following to connect a Fiber CAP L to a passive RF antenna.

- 1 Connect the CAP L ANT 1 or ANT 2 connector to a passive RF antenna.
 - a Locate the 50Ω coaxial cables obtained for this installation; see ["Obtain the Required Materials" on page 23](#).
 - b Install the passive antennas per the manufacturer's installation instructions. For MIMO CAP L, if connecting both ANT connectors, you will connect the CAP L to either two separate external passive antennas or to two ports on a cross-polarized dual antenna. Each connector supports two RF bands (see [Table 12](#)).

Table 12. Mapping Frequency Bands to Antennas

	ID Number	Ant 1	Ant 2
17E/17E/23/23	7770203-000x	17E/23	17E/23
18/21/26/26	7770209-000x	18/26	21/26
17E/17E/19/19	7770356-000x	17E/19	17E/19
9/18/18/21	7776595-000x	9/18	18/21
7/80-85/17E/19	7776596-000x	7/80-85	17E/19
17E/19/23/25TDD	7776597-000x	23/25TDD	17E/19
9/18/21/26	7776598-000x	9/18	21/26
8/9/18/21	7776641-000x	8/9	18/21
8/18/21/26	7776643-000x	8/18	21/26

- c Remove the plastic-protective cap from the 4.3-10 connectors.
 - d Remove the IP67/EMI blank plug from the ANT 1/2 connector.
 - e Connect the passive multi-band antenna to the ANT 1 or ANT 2 connector using coaxial cable with the least amount of loss possible.
 - If the 50Ω coaxial cable has a push-pull connector, make sure the cable is seated firmly in the ANT 1 or ANT 2 connector.
 - If the 50Ω coaxial cable has a threaded connector, torque the connector 5 N-m (3.69 ft-lb). Do not over-tighten the connector.
 - f Connect the other end of the 50Ω coaxial cable to the passive antenna installed in [Step b](#).
- 2 If necessary, repeat [Step 1 on page 60](#) to connect a 50Ω coaxial cable to the other ANT connector.

Connect the Fiber CAP L to a Classic CAN or TEN

The following steps are applicable to a singular Fiber CAP L, or to the Primary CAP L in a cascade.

- 1 Connect the CAP L Optical Port 1 as appropriate for this installation.
 - a Remove the dust cap from the CAP L Optical Port 1 connector and the connectors on the SMF or MMF.
 - b Follow the local cleaning technique to clean Optical Port 1.
 - c Clean the connectors on the SMF or MMF following the fiber supplier's recommendations.
 - d Install the SFP+ connector and Optical OCTIS Kit on the end of the SMF or MMF that will connect to the CAP L.
 - i Follow the limitations per the maximum range described in ["SFP+ Modules" on page 9](#).

- ii Connect that end of the SMF or MMF to the CAP L Optical Port 1 connector. (Refer to the technical data sheet that ships with the OCTIS Kit for further information.)
- e Connect the other end of the SMF or MMF to an open port on an OPT Card installed in Slots L1-L4 in the TEN or Classic CAN. WCS Slots L5-L8 cannot be used to connect APs.



If installing a CAP L with the CAP L Hybrid Fiber Splice Box Kit (PN 7781091-xx), the optical fiber will be hanging from the Hybrid Fiber Splice Box.

- 2 Do one of the following:
 - If you are cascading a Secondary Fiber CAP L, go to "[Cascade a Secondary Fiber CAP L \(Optional\)](#)" on [page 61](#).
 - If you are not connecting an Secondary Fiber CAP L, skip to "[Connect to Vdc Power](#)" on [page 62](#).

Cascade a Secondary Fiber CAP L (Optional)

Do the following if you are connecting a Primary Fiber CAP L to a Secondary CAP L.

- 1 Read and follow the rules in "[Cascade Rules for Fiber CAP Ls](#)" on [page 11](#).
- 2 Do the following on the Primary Fiber CAP L.
 - a Raise the lever on the EMI/IP67 cap on the Optical Port 2 connector, and then remove the connector's cap.
 - b Follow the local cleaning technique to clean Optical Port 2.
- 3 Connect the SMF or MMF to the Primary Fiber CAP L.
 - a Remove the cap from the connector on one end of the SMF or MMF.
 - b Follow the fiber supplier's recommendations to clean the connectors on the SMF or MMF.
 - c Install an SFP+ Module and Optical OCTIS Kit on the end of the cable that will connect to the Primary CAP L, and then connect it to the Optical Port 2 connector on the Primary Fiber CAP L. (Refer to the technical data sheet that ships with the OCTIS Kit for further information.)
- 4 Do the following on the Secondary CAP L.
 - a Raise the lever on the EMI/IP67 cap on its Optical Port 1 connector and remove the connector's cap.
 - b Follow the local cleaning technique to clean Optical Port 1 on the Secondary CAP L.
- 5 Connect the SMF or MMF to the Secondary Fiber CAP L.
 - a Remove the cap from the connector on the other end of the SMF or MMF.
 - b Follow the fiber supplier's recommendations to clean the connectors on the SMF or MMF.
 - c Install the SFP+ and Optical OCTIS Kit on the end of the cable that will connect to the Secondary CAP L, and then connect it to the Optical Port 1 connector on the Secondary Fiber CAP L. (Refer to the technical data sheet that ships with the OCTIS Kit for further information.)
- 6 Do one of the following:
 - If you are connecting an auxiliary Ethernet device, go to "[Connect an External Ethernet Device \(Optional\)](#)" on [page 62](#).
 - If you are not connecting an auxiliary Ethernet device, skip to "[Connect to Vdc Power](#)" on [page 62](#).

Connect an External Ethernet Device (Optional)



If you are not connecting an Ethernet device, do not remove the plug from Port A.

If connecting an Ethernet device to a cascaded pair, this must be the Primary Fiber CAP L.

- 1 Read and follow the rules in "[Cat6A Cable Requirements for Ethernet Devices](#)" on page 12.
- 2 Raise the lever on the EMI/IP67 cap on the Port A connector, and then remove the connector's plug.
- 3 Follow the local cleaning technique to clean Port A.
- 4 Install an Ethernet OCTIS Kit on the end of the CAT cable that will connect to the Fiber CAP L, and then connect that end of the cable to Port A on the Fiber CAP L. (Refer to the technical data sheet that ships with the OCTIS Kit for further information.)



Cat6A, including all Cat6A cables, Cat6A Patch Cords, and Patch Panels, between Port A on the Fiber CAP L and an auxiliary Ethernet device cannot exceed 3 meters (9.8 feet); see [Figure 5 on page 12](#).

- 5 Connect the other end of the CAT cable to the Ethernet port of the auxiliary device.
- 6 Go to "[Connect to Vdc Power](#)" on page 62.

Connect to Vdc Power

Connect the Vdc Power connector as appropriate for this installation. The CAP L is powered on as soon as you connect the CAP L to a power source; see "[Powering on a Fiber CAP L](#)" on page 62.

- If powering the CAP Ls with local AC/DC power adapters, please see "[Wiring the AC/DC Power Supply Kit](#)." on page 38.
- If powering the CAP Ls with the Hybrid Fiber Splice Box kits, please see "[Mounting a CAP L with a Hybrid Fiber Splice Box Kit](#)" on page 43.

POWERING ON A FIBER CAP L

The CAP L is powered on as soon as power is connected to it. Under normal operating conditions, the Power LED turns on briefly when the unit is first detected. It will then go out briefly, followed by an initialization period during which the Power LED flashes slowly while the CAP L is configured. The Power LED remains a steady blue (not flashing) once the unit reaches a fully operational state, which typically occurs within 45 seconds.

The Power LED behavior for a Fiber CAP L is as follows:

- Off—CAP L is not powered on.
- Steady blue—CAP L is powered on and operational.
- Slow flashing blue—CAP L is powered on and initializing.
- Rapid flashing blue—CAP L Unit Identifier active via the **Flash LED** function in the Era GUI.

CAP L MAINTENANCE

The following sections tell you how to remove a CAP L from mounting brackets and provides preventative maintenance instructions.

Remove a CAP L from a Wall or Ceiling Mount

Should you need to remove the CAP L from a wall or ceiling mount, do the following.

- 1 Unplug the CAP L cables.
- 2 If a ground wire is installed, loosen the grounding screw and remove the ground wire.
- 3 Reverse the installation steps that correspond to how this CAP L is mounted.

Preventative CAP L Maintenance for CAP Ls with the Fan Kit Option

The CAP L does not require extensive preventative maintenance measures. However, checking the cleanliness of a CAP L that has the Fan Kit option at regularly-scheduled intervals is recommended, particularly the enclosure vents, which helps maintain the longevity of the fans and heat sinks. [Figure 23](#) shows two different CAP L configurations to help you find the enclosure vents.

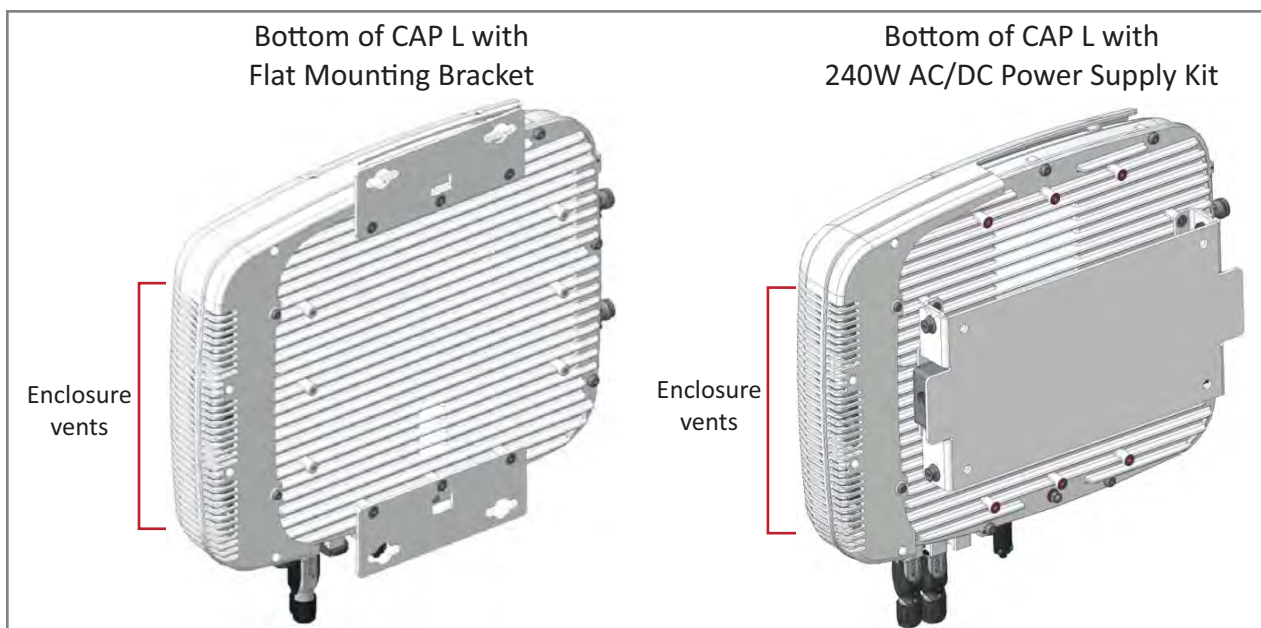

Figure 23. Examples of CAP L Fan Vent Locations

CONTACTING COMMSCOPE

The following sections tell you how to contact CommScope for additional information or for assistance.

CMS Global Technical Support

The following sections tell you how to contact the CommScope Mobility Solutions (CMS) Technical Support team. Support is available 7 days a week, 24 hours a day.

Telephone Helplines

Use the following Helpline telephone numbers to get live support, 24 hours a day:

- | | |
|---------------------------------|---|
| 24x7 | +1 888-297-6433 (Toll free for U.S. and Canada) |
| EMEA 8:00-17:00 (UTC +1) | + 800 73732837 (Toll free for parts of EMEA and Australia)
+ 49 909969333 (Toll charge incurred) |

Calls to an EMEA Helpline outside of the 8:00 to 17:00 time frame will be forwarded to the 24x7 Helpline.

Online Support

To go to the CommScope Wireless Support Request web site from which you can initiate a Technical Support ticket, do one of the following:

- Scan the QR Code to the right.
- If viewing this document online as a PDF, click on the following URL link:
<http://www.commscope.com/wisupport>
- Enter the preceding URL into your web browser, and then press **ENTER** on your keyboard.



Waste Electrical and Electronic Equipment Recycling

Country specific information about collection and recycling arrangements per the Waste Electrical and Electronic Equipment (WEEE) Directive and implementing regulations is available on CommScope's website.

To access information on the CommScope recycling program, do any of the following:

- Scan the QR Code to the right.
- If viewing this document online as a PDF, click on the following URL link:
<http://www.commscope.com/About-Us/Corporate-Responsibility-and-Sustainability/Environment/Recycling/>
- Enter the preceding URL into your web browser, and then press **ENTER** on your keyboard.



Hardware to Software Mapping Information

- 1 Scan the QR Code to the right to view or download the minimum software requirements for each of the DCCS hardware modules. Alternatively, you can go to the following web address to access the portal:



http://www.commscope.com/collateral/DCCS_HW_SW_Mapping/

- 2 Click on a document link to open it, or right click on the link and select the **Save target as...** option from the contextual menu.

Mobility Solutions Technical Training

- 1 To access training on the online CommScope Mobility Solutions site, do one of the following:

- Scan the QR Code to the right.
- If viewing this document online as a PDF, click on the following URL link.



<https://commscope.netexam.com>

- Enter the preceding URL into your web browser, and then press **ENTER** on your keyboard.
- 2 Review the courses listed in separate course panels; for further information on a course, click its **Full details** button. Instructor-led courses are conducted in North America and Europe. Before choosing a course, please verify the region.
 - 3 To view the course schedule and register, click **Course Registration** at the top of the course page; this opens the **Partner Learning Center Login** page.
 - If you have an account, enter your **Username** and **Password**, and then click **Login**. (Click on the **Reset Password** link if you do not have your login information.)
 - If you don't have an account, click on the **Create New User Account** link under the **Login** button, and follow the prompts.

Once you have logged in, you will see a list of available class dates.

- 4 Click the date you prefer and select the **Enroll** or **Register Now** button to enroll. Follow the prompts through the payment process.
- 5 Click either the **Available Training** or **Calendar** tab to view other training courses.

For training related questions, please contact the CommScope DAS and Small Cell Institute at one of the following emails, as appropriate for your location:

Americas: DASTrainingUS@CommScope.com

EMEA: DASTrainingEMEA@CommScope.com

Accessing Era/ION-E Series User Documentation

- 1 Scan the QR Code to the right to go directly to the CommScope DCCS Customer Portal, where you can access the DCCS user documentation.



Alternatively, you can go to the following web address to access the portal:

<https://www.mycommscope.com>

- 2 Access to the Customer Portal requires a user account and password. On the Sign In page, do one of the following:
 - If you have an account, enter your Email address and Password, and then click Sign In.
 - If you don't have an account, click New user registration, and follow the prompts.
- 3 Click DCCS to open the site.
- 4 Select your site, and then click on a product link to open the product page.
- 5 Click on the title of any document to open it.

