

ION™-M7P/8P S (Q cabinet)



Optical Remote Unit



**User's Manual
MF0132APA**

© Copyright 2010 CommScope, Inc.

All rights reserved.

Andrew Solutions is a trademark of CommScope, Inc.

All information contained in this manual has been revised thoroughly. Yet Andrew Solutions accepts no liability for any omissions or faults.

Andrew Solutions reserves the right to change all hard- and software characteristics without notice.

Names of products mentioned herein are used for identification purposes only and may be trademarks and / or registered trademarks of their respective companies.

No parts of this publication may be reproduced, stored in a retrieval system, transmitted in any form or by any means, electronic, mechanical photocopying, recording or otherwise, without prior written permission of the publisher.

Andrew Wireless Systems GmbH, 12-April-2010

TABLE OF CONTENTS

1. GENERAL	7
1.1. USED ABBREVIATIONS	7
1.2. HEALTH AND SAFETY WARNINGS	9
1.3. ABOUT ANDREW SOLUTIONS	11
1.4. INTERNATIONAL CONTACT ADDRESSES FOR WIG CUSTOMER SUPPORT	12
2. INTRODUCTION	15
2.1. PURPOSE	15
2.2. THE ION-M7P/8P S (INTELLIGENT OPTICAL NETWORK; MMR)	15
3. FUNCTIONAL DESCRIPTION	17
3.1. GENERAL	17
3.2. COMPONENTS OF THE ION-M7P/8P S REMOTE UNIT	18
3.3. OPTIONAL EQUIPMENT - RELAY ALARM CONNECTING BOARD	18
4. COMMISSIONING	19
4.1. MECHANICAL INSTALLATION	19
4.1.1. General	19
4.1.2. Wall and Pole Mounting	20
4.2. ELECTRICAL INSTALLATION	21
4.2.1. General	21
4.2.2. Connections	22
4.2.3. Grounding	22
4.2.4. Power Connection	23
4.3. CONNECTION OF THE ANTENNA CABLES	24
4.4. CONNECTION OF THE RF CABLES MAIN UNIT TO COMBINING UNIT	24
4.5. OPTICAL-FIBRE-CABLE CONNECTION - RULES	25
4.5.1. Protective Plug	26
4.5.2. Protective-Tube Kit	28
4.6. COMMISSIONING	30

5. ALARMS	33
5.1. BITE AND ALARMS	33
5.2. HANDLING OF ALARMS	33
5.3. ALARM STATUS	33
5.4. STATUS LED ALARMS	33
5.5. RELAY ALARM CONNECTING BOARD	35
5.5.1. External-Alarm Inputs and Outputs	35
5.5.2. Layout and Connector Description	36
5.6. REDUNDANCY RELAY CONFIGURATION	37
5.7. TROUBLESHOOTING	38
6. MAINTENANCE	39
6.1. GENERAL	39
6.2. OPENING AND CLOSING OF THE CABINET	40
6.3. REPLACEMENT OF POWER SUPPLY	41
6.4. REPLACEMENT OF FAN UNIT	42
7. APPENDIX	43
7.1. LAYOUT	43
7.2. SPECIFICATIONS	44
8. INDEX	45

FIGURES AND TABLES

figure 3-1 Configuration of an ION-M7P/ 8P S.....	17
figure 3-2 ION-M7P/8P S, lid	18
figure 3-3 ION-M7P/8P S, base	18
figure 4-1 Wall mounting.....	20
figure 4-2 Pole mounting	20
figure 4-3 ION-M7P/8P S, connector flange, exemplary	22
figure 4-4 Grounding bolt.....	22
figure 4-5 AC mains plug	23
figure 4-6 DC mains plug.....	23
figure 4-7 Protective-plug assembly	26
figure 4-8 Tube-kit installation.....	29
figure 5-1 Alarm triggering	34
figure 5-2 Relay alarm connecting board, description of connectors	36
figure 5-3 Alarm-output contacts, alarm condition	37
figure 5-4 Redundancy connection, cabling.....	37
figure 5-5 Redundancy RF relay.....	37
figure 5-6 Redundancy connectors, Main Unit and Substitute Unit.....	37
figure 6-1 Locker with key.....	40
figure 6-2 Front and top cover screws	40
figure 6-3 Power supply screws.....	41
figure 6-4 Fan unit screws	42
figure 6-5 Fan-connector cable.....	42
figure 7-1 Layout of ION-M7P/8P S, lid	43
figure 7-2 Layout of ION-M7P/8P S, base	44
table 1-1 List of international contact addresses.....	13
table 5-1 Status LED alarms.....	34
table 5-2 Relay alarm connecting board connectors, pin assignment.....	36
table 6-1 Specified torques for various screw types	39

For your notes:

1. GENERAL

1.1. USED ABBREVIATIONS

ALC	Automatic Level Control
AMPS	American Mobile Phone System or Advanced Mobile Phone System
APAC	Automatic Power Adjustment Circuit
AWS	Advanced Wireless Services
BBU	Battery Backup Unit
BCCH	Broadcast Control Channel
BITE	Built-In Test Equipment
BTS	Base Transceiver Station
CDMA	Code Division Multiple Access
CEPT	Conf�rence Europ�enne des Postes et T�l�communications
CF	Center Frequency
CFO	Center Frequency Offset
CPD	Channel Power Detection
DL	Downlink
EDGE	Enhanced Data Rates for GSM Evolution
ESD	Electrostatic Discharge
ETS	European Telecommunication Standard
ETSI	European Telecommunication Standards Institute
FCC	Federal Communications Commission
FSK	Frequency Shift Keying
GSM	Global System for Mobile Communication
GUI	Graphical User Interface
I ² C-Bus	Inter Integrated Circuit Bus (Philips)
ID No	Identification Number
IF	Intermediate Frequency
LMT	Local Maintenance Terminal
LNA	Low-Noise Amplifier
MIMO	Multiple Input Multiple Output
MS	Mobile Station
NSO	Network Supervision Option
OMC	Operation and Maintenance Center
OTRx	Optical Transceiver = SRMU (Subrack Master Unit)
PCMCIA	Personal Computer Modem Communication International Association
PCS	Personal Communication System
PSTN	Public Switched Telephone Network
Rev	Revision
RF	Radio Frequency
RLP	Radio Link Protocol
RSSI	Receive Signal Strength Indication
RTC	Real-Time Clock
RX	Receiver
SCL	Serial Clock
SDA	Serial Data

SISO	Single Input Single Output
SPD	Switching Point Detector
SRMU	Subrack Master Unit = OTRx (Optical Transceiver)
TCH	Traffic Channel
TDD	Time-Division Duplex
TDMA	Time Division Multiple Access
TX	Transmitter
UL	Uplink
UMR	Universal Measurement Receiver
UMTS	Universal Mobile Telecommunication System
UPS	Uninterruptible Power Supply
VSWR	Voltage Standing Wave Ratio
WDM	Wavelength Division Multiplex
WIG	Wireless Innovations Group
WiMAX	Worldwide Interoperability for Microwave Access

1.2. HEALTH AND SAFETY WARNINGS



1. Only suitably qualified personnel is allowed to work on this unit and only after becoming familiar with all safety notices, installation, operation and maintenance procedures contained in this manual.
2. Read and obey all the warning labels attached to the unit. Make sure that the warning labels are kept in a legible condition and replace any missing or damaged labels.
3. Obey all general and regional installation and safety regulations relating to work on high voltage installations, as well as regulations covering correct use of tools and personal protective equipment.
4. Keep operating instructions within easy reach and make them available to all users.
5. It is the responsibility of the network provider to implement prevention measures to avoid health hazards which may be associated to radiation from the antenna(s) connected to the unit.
6. For US and Canadian installations: To comply with FCC RF exposure compliance requirements, the following antenna installation and device operating configurations must be satisfied: A separation distance of at least 4 m must be maintained between the antenna of this device and all persons. RF exposure compliance may need to be addressed at the time of licensing, as required by the responsible FCC Bureau(s), including antenna co-location requirements of 1.1307(b)(3). Maximum permissible antenna gain is 17 dBi.
7. Make sure access is restricted to qualified personnel.
8. Only licence holders for the respective frequency range are allowed to operate this unit.
9. Use this equipment only for the purpose specified by the manufacturer. Do not carry out any modifications or fit any spare parts which are not sold or recommended by the manufacturer. This could cause fires, electric shock or other injuries.
10. Due to power dissipation, the remote unit may reach a very high temperature. Do not operate this equipment on or close to flammable materials.
11. Before opening the unit or (dis-)connecting the mains connector at the remote unit, ensure that mains supply is disconnected.



12. ESD precautions must be observed! Before commencing maintenance work, use the available grounding system to connect ESD protection measures.

13. This unit complies with European standard EN60950.

14. Make sure the system settings are according to the intended use (see also product information of manufacturer) and regulatory requirements are met.

15. Although the remote unit is internally protected against overvoltage, it is strongly recommended to earth the antenna cables close to the antenna connectors of the remote unit for protection against atmospheric discharge.



16. Laser radiation – Class 1! Do not stare into the beam; do not view it directly or with optical instruments.

1.3. ABOUT ANDREW SOLUTIONS

Andrew Wireless Systems GmbH based in Buchdorf/ Germany, is a leading manufacturer of coverage equipment for mobile radio networks, specializing in low cost, high performance, RF and optical repeaters. Our optical distributed networks and RF repeater systems provide coverage for every application: outdoor use, indoor installations, tunnels, subways and many more.

Andrew Wireless Systems GmbH belongs to the *Wireless Innovations Group (WIG)*. Being a part of *Andrew Solutions*, *WIG* has unparalleled experience in providing RF coverage and capacity solution for wireless networks in both indoor and outdoor environment.

Andrew Solutions, a *CommScope Company*, is the foremost supplier of one-stop, end-to-end radio frequency (RF) solutions. Our products are complete solutions for wireless infrastructure from top-of-the-tower base station antennas to cable systems and cabinets, RF site solutions, signal distribution, and network optimization.

Andrew Solutions has global engineering and manufacturing facilities. In addition, it maintains field engineering offices throughout the world.

We operate a quality management system in compliance with the requirements of ISO 9001. All equipment is manufactured using highly reliable material. In order to ensure constant first-rate quality of the products, comprehensive quality monitoring is conducted at all fabrication stages. Finished products leave the factory only after a thorough final acceptance test, accompanied by a test certificate guaranteeing optimal operation.

The declaration of conformity for the product is available upon request from the local sales offices or from *Andrew Solutions* directly.

To make the utmost from this unit, we recommend you carefully read the instructions in this manual and commission the unit only according to these instructions.

For technical assistance and support, contact the local office or *Andrew Solutions* directly at one of the following addresses listed in the next chapter.

1.4. INTERNATIONAL CONTACT ADDRESSES FOR WIG CUSTOMER SUPPORT

Wireless Innovations Group (WIG)

Americas:

<i>Canada</i>	<i>United States</i>
<p style="text-align: center;">Andrew Solutions Canada</p> <p>620 North Greenfield Parkway Garner, NC 27529 U.S.A.</p> <p>Mail</p> <p>Phone +1-905-878-3457 (Office) +1 416-721-5058 (Mobile)</p> <p>Fax +1-905-878-3297</p> <p>E-mail Peter.Masih@andrew.com WIsupport.us@andrew.com</p>	<p style="text-align: center;">Andrew Solutions, Andrew LLC, A CommScope Company</p> <p>620 North Greenfield Parkway Garner, NC 27529 U.S.A.</p> <p>Mail</p> <p>Phone +1-888-297-6433</p> <p>Fax +1-919-329-8950</p> <p>E-mail WIsupport.us@andrew.com</p>
<i>Brazil & South America</i>	<i>Mexico, Central America & Caribbean region</i>
<p style="text-align: center;">Andrew Solutions, A CommScope Company</p> <p>Av. Com. Camilo Julio 1256 Predio B Zonal Industrial CP 597 Sorocaba SP 18086-000 Brazil</p> <p>Mail</p> <p>Phone + 55-15-9104-7722</p> <p>Fax + 55-15-2102-4001</p> <p>E-mail WIsupport@andrew.com</p>	<p style="text-align: center;">Andrew Solutions Mexico</p> <p>Monte Elbruz 124-402A Col. Palmas Polanco 11560 Mexico, D.F. Mexico</p> <p>Mail</p> <p>Phone + 52-55-1346-1900 (Office) +52-1-55-5419-5260 (Mobile)</p> <p>Fax +52-55-1346-1901</p> <p>E-mail WIsupport@andrew.com</p>

APAC Countries:

<i>China</i>	<i>Australia</i>
<p style="text-align: center;">Andrew Solutions Hong Kong</p> <p>Room 915 Chevalier Commercial Centre 8 Wang Hoi Rd Kowloon Bay SAR Hong Kong</p> <p>Mail</p> <p>Phone +852-310-661-00</p> <p>Fax +852-2751-7800</p> <p>E-mail WISupport.china@andrew.com</p>	<p style="text-align: center;">Andrew Corporation (Australia) LLC Pty Ltd.</p> <p>Unit 1 153 Barry Road Campbellfield VIC 3061 Australia</p> <p>Mail</p> <p>Phone +613-9300-7969</p> <p>Fax +613-9357-9110</p> <p>E-mail WIsupport.australia@andrew.com</p>

Europe:

United Kingdom		France	
	Andrew Solutions UK Ltd Unit 15, Ilex House Mulberry Business Park Fishponds Road Wokingham Berkshire RG41 2GY England		Andrew Solutions France 28, Rue Fresnel Z.A Pariwest BP 182 78313 Coignières Cedex France
Mail		Mail	
Phone	+44-1189-366-792	Phone	+33 1 30 05 45 50
Fax	+44-1189-366-773	Fax	+33 1 34 61 13 74
E-mail	Wlsupport.uk@andrew.com	E-mail	Wlsupport@andrew.com
Germany		Czech Republic	
	Andrew Wireless Systems GmbH Industriering 10 86675 Buchdorf Germany		Andrew Solutions Czech Republic C-Com, spol. s r.o U Moruší 888 53006 Pardubice Czech Republic
Mail		Mail	
Phone	+49-9099-69-0	Phone	+420-464-6280-80
Fax	+49-9099-69-930	Fax	+420-464-6280-94
E-mail	Wlsupport@andrew.com	E-mail	Wlsupport@andrew.com
Austria		Switzerland	
	Andrew Wireless Systems (Austria) GmbH Weglgasse 10 Wien-Schwechat 2320 Austria		Andrew Wireless Systems AG Tiergartenweg 1 CH-4710 Balsthal Switzerland
Mail		Mail	
Phone	+43-1706-39-99-10	Phone	+41-62-386-1260
Fax	+43-1706-39-99-9	Fax	+41-62-386-1261
E-mail	Wlsupport.austria@andrew.com	E-mail	support.ch@andrew.com
Italy		Spain & Portugal	
	Andrew Wireless Systems S.r.l., Faenza, Italy Via de Crescenzi 40 Faenza 48018 Italy		Andrew Solutions España S.A. C/ Salvatierra, 5 - 3 ^a pt. 28034 Madrid Spain
Mail		Mail	
Phone	+39-0546-697111	Phone	+34-91-745-20 40
Fax	+39-0546-682768	Fax	+34-91-564-29 85
E-mail	Wlsupport.italia@andrew.com	E-mail	Wlsupport.iberia@andrew.com

table 1-1 List of international contact addresses

For your notes:

2. INTRODUCTION

2.1. PURPOSE

Cellular telephone systems transmit signals in two directions between a base transceiver station (BTS) and mobile stations (MS) within the signal coverage area.

If weak signal transmissions occur within the coverage area because of indoor applications, topological conditions or distance from the transmitter, extension of the transmission range can be achieved by means of an optical distribution system.

Such a system contains an optical master unit and several remote units. The number of the remote units depends on the hardware and software configuration. The remote units are connected to the master unit with optical links. The optical loss must be less than 10 dB inclusive optical couplers or splitters.

The master unit is the connection to the base transceiver stations. The configuration of a master unit depends on the number of the remote units and the frequency range.

The optical transmission uses WDM-systems with a wavelength of 1550 nm in the uplink and 1310 nm in the downlink.

2.2. THE ION-M7P/8P S (INTELLIGENT OPTICAL NETWORK; MMR)

The Andrew ION-M7P/8P S is a multi-operator remote unit with various extension units. It is used in conjunction with a master unit in the ION optical distribution system. This system transports the entire 700 MHz public safety and 800 MHz LMR frequency bands simultaneously, providing a cost-efficient solution for distributing capacity from one or more base stations.

The ION-M7P/8P S transports signals on the RF layer in a very inexpensive manner. This means that multiple operators and multiple technologies are moved simultaneously from a cluster of base stations to a remote location over the same fiber.

The ION optical distribution system is a cost-effective coverage solution for dense urban areas, tunnels, subway, airports, convention centers, high-rise buildings and other locations where physical structures increase path loss. It has been specifically designed to reduce zoning problems and to provide homogeneous coverage. The compact, mechanical design is specifically architected to mount at poles or along side structures in such a way that it has a minimum visual impact.

The ION-M7P/8P S performance is available both in single or multi-band configuration supporting 700 MHz, and 800 MHz in parallel. It has been specifically tested and optimized for TDMA, CDMA2000, and WCDMA. Furthermore it is provisioned for future improvements to modulations (e.g. HSPA, EV-DO and OFDM) and frequency bands. In addition it is backwards compatible to legacy standards such as Analog.

The ION is easily set-up and supervised via a graphical user interface (GUI). Remote units can be commissioned through the use of built-in test equipment. An auto leveling function compensates for the optical link loss making installation easy and quick. The entire system may be monitored remotely via an Andrew OMC. This is a comprehensive management platform with SNMP protocol and X.733 standard implemented. Should a sophisticated interface not be required, the master unit can be directly connected to the alarm interface of a base station via relay alarming.

Features:

Multi-band, multi-operator support

Reduced visual impact form factor

High, efficient power amplifier

Single fiber for multiple bands and multiple remotes

Comprehensive operations and management system for configuration and alarming

OMC with SNMP according to X.733 standard

Easy installation and commissioning

Redundancy configuration option

3. FUNCTIONAL DESCRIPTION

3.1. GENERAL

The following figure shows the configuration of an ION-M7P/8P S:

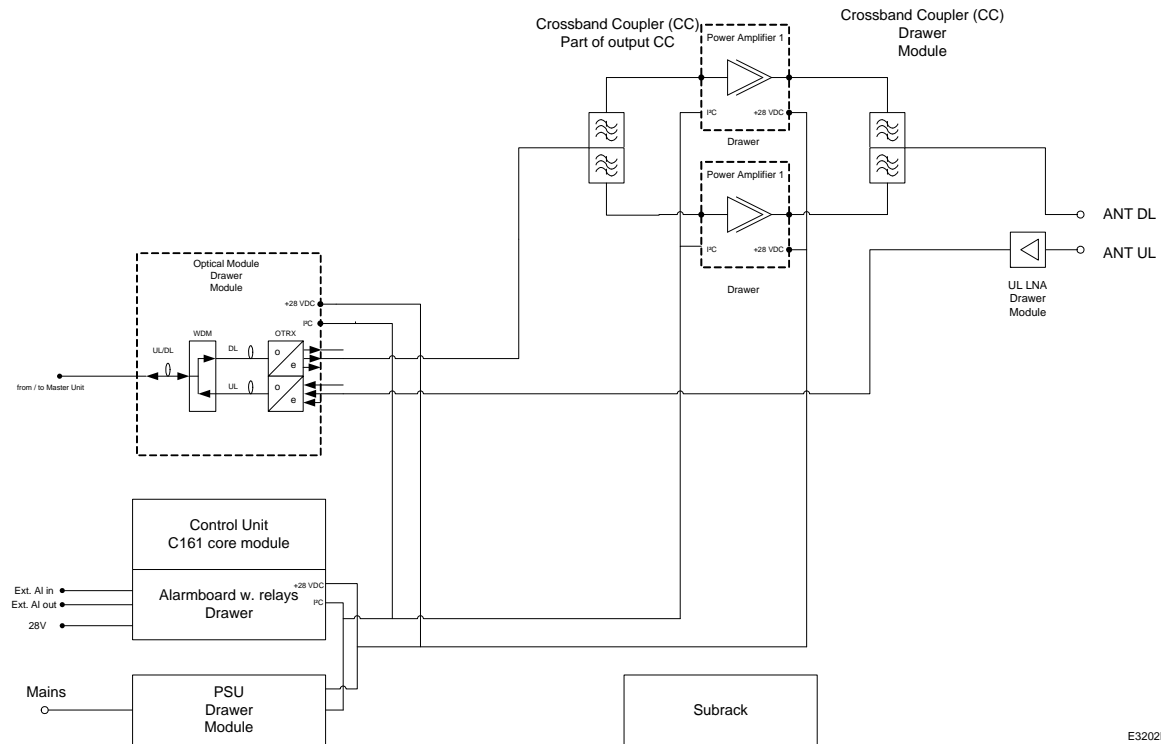

E3202B0

figure 3-1 Configuration of an ION-M7P/ 8P S

3.2. COMPONENTS OF THE ION-M7P/8P S REMOTE UNIT

The actual configuration of the remote unit can be seen at the configuration list which is part of the delivery.

The following figure shows an exemplary view of an ION-M7P/8P S remote unit to illustrate the individual components.

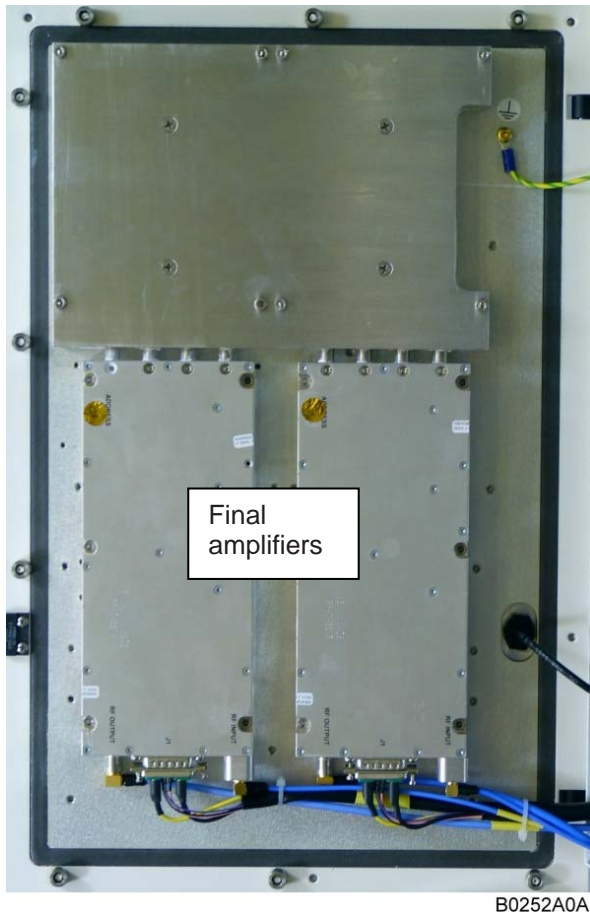

figure 3-2 ION-M7P/8P S, lid

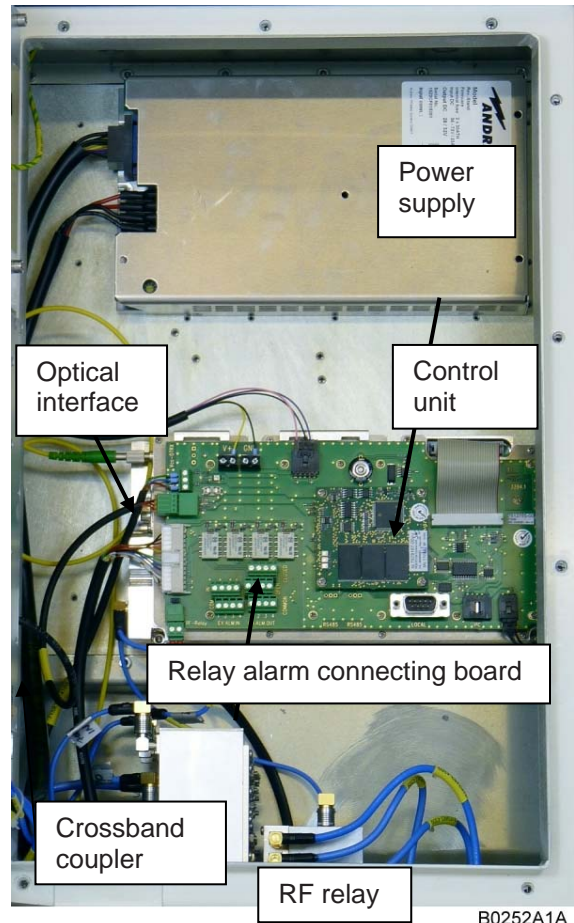

figure 3-3 ION-M7P/8P S, base

3.3. OPTIONAL EQUIPMENT - RELAY ALARM CONNECTING BOARD

For further information on the relay alarm connecting board please refer to chapter 5.5 *Relay Alarm Connecting Board*.

4. COMMISSIONING

4.1. MECHANICAL INSTALLATION

4.1.1. General

Read the health and safety warnings in chapter *1.2 Health and Safety Warnings*.

1. Do not install the unit in a way or at a place where the specifications outlined in the Environmental and Safety Specifications leaflet of the manufacturer are not met.
2. It is strongly recommended to install the unit vertically. If a different installation of the remote unit is required, please contact customer service for further information.
3. It is recommended only to use the mounting hardware delivered by the manufacturer. If different mounting hardware is used, the specifications for stationary use of the remote unit must not be exceeded.

 **Note:** Exceeding the specified load limits may cause the loss of warranty!

4.  The unit is considerably heavy. Make sure that a suitable mounting surface is used. Ensure there is adequate manpower to handle the weight of the system.
5. Due to power dissipation, the remote unit may reach a very high temperature. Ensure sufficient airflow for ventilation. Above and below the unit a minimum distance of 300 mm to ceiling, floor, etc. has to be kept. Also observe the instructions in the individual mounting procedures.
6. For outdoor installations, the pre-mounted front cover must be installed.
7. For indoor installations where the ambient temperature can reach above 40°C, the cover has to be removed.
8. When connecting and mounting the cables (RF, optical, mains, ...) ensure no water can penetrate into the unit through these cables.

If any different or additional mounting material is used, ensure that the mounting remains as safe as the mounting designed by the manufacturer. Ensure that the static and dynamic strengths are adequate for the environmental conditions of the site. The mounting itself must not vibrate, swing or move in any way that might cause damage to the remote unit.

4.1.2. Wall and Pole Mounting

Wall and pole mounting equipment for the unit is available. For the according mounting please refer to the mounting plan (drawing) that is part of the delivery.

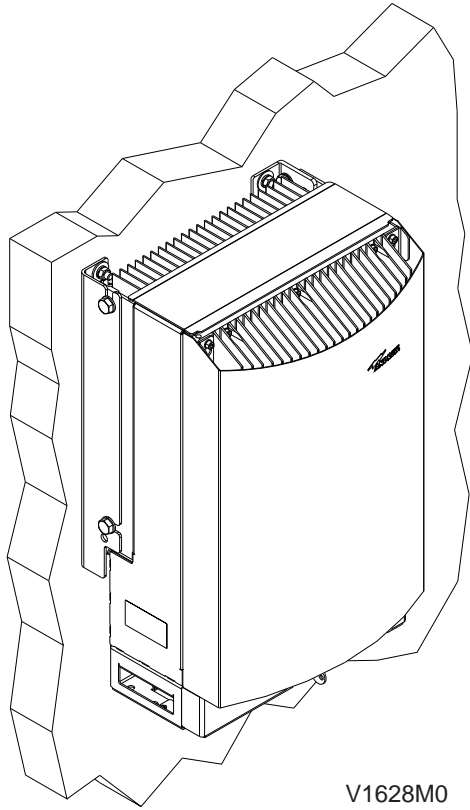

figure 4-1 Wall mounting

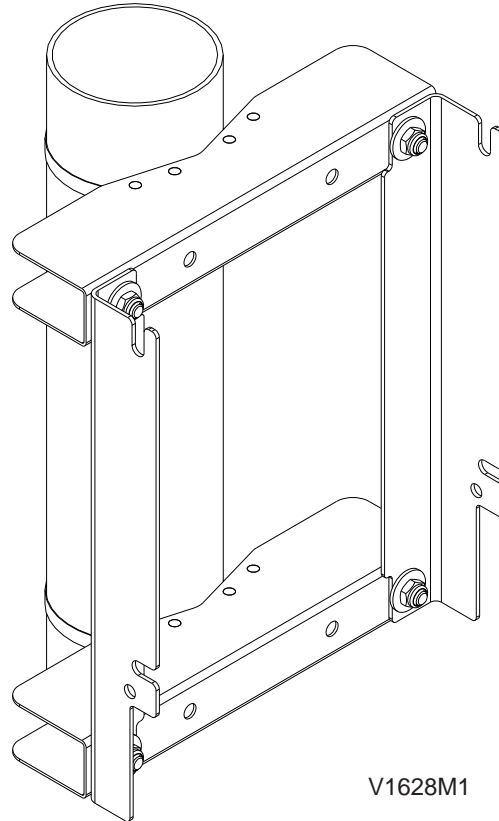

figure 4-2 Pole mounting

4.2. ELECTRICAL INSTALLATION

4.2.1. General

Read the health and safety warnings in chapter *1.2 Health and Safety Warnings*.



1. This unit contains dangerous voltages. Loss of life, severe personal injury or property damage can be the result if the instructions contained in this manual are not followed.
2. It is compulsory to ground the unit before connecting power supply. A grounding bolt is provided on the cabinet to connect the ground-bonding cable.
3. Although the remote unit is internally protected against overvoltage, it is strongly recommended to earth the antenna cables close to the antenna connectors of the remote unit for protection against atmospheric discharge. In areas with strong lightning it is strongly recommended to insert additional lightning protection.
4. If the mains connector of the remote unit is not easily accessible, a disconnect device in the mains circuit must be provided within easy reach.
5. Before connecting or disconnecting the mains connector at the remote unit, ensure that mains supply is disconnected.
6. Make sure that an appropriate circuit breaker and an overcurrent limiting device are connected between mains and remote unit.
7. A connection of mains supply to a power socket requires the power socket to be nearby the remote unit.
8. Incorrectly wired connections can destroy electrical and electronic components.
9. To avoid corrosion at the connectors caused by electrochemical processes, the material of the cable connectors must not cause a higher potential difference than 0.6 V (see electrochemical contact series).
10. It is sufficient to tighten 7/16-antenna connectors hand-screwed. Any use of a tool (e.g. pair of pliers) might cause damage to the connector and thus lead to malfunctioning of the remote unit.
11. For unstabilized electric networks which frequently generate spikes, it is advised to use a voltage limiting device.
12. The unit complies with the surge requirement according to EN 61000-4-5 (fine protection); however, it is recommended to install an additional medium (via local supply connection) and/or coarse protection (external surge protection) depending on the individual application in order to avoid damage caused by overcurrent.
13. Observe the labels on the front panels before connecting or disconnecting any cables.

4.2.2. Connections

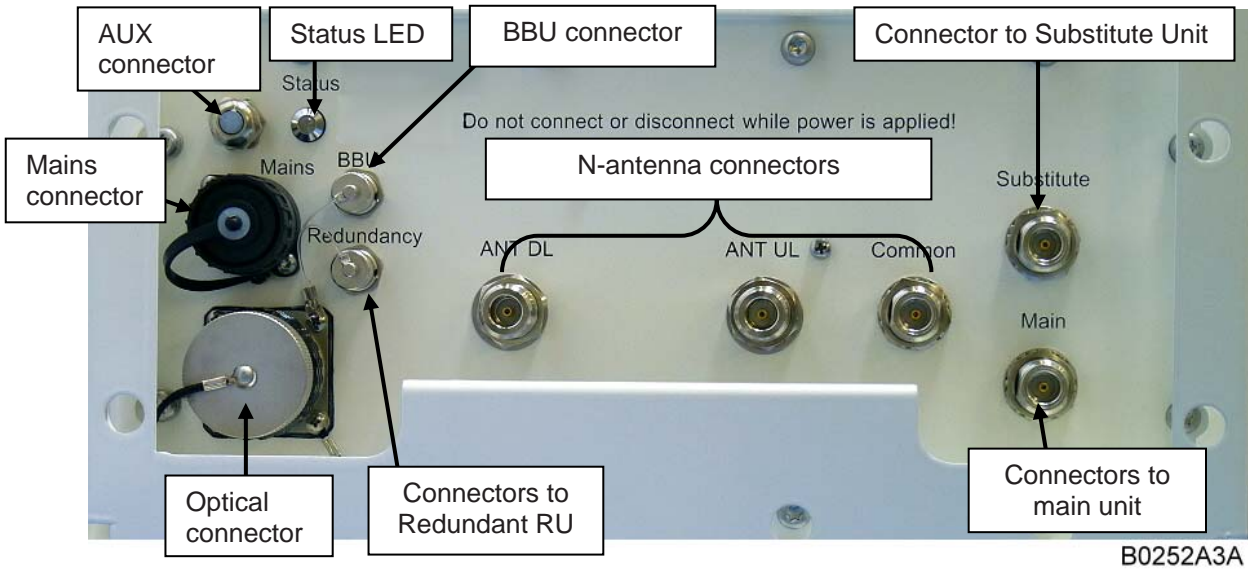

figure 4-3 ION-M7P/8P S, connector flange, exemplary

4.2.3. Grounding

Grounding must be carried out. Connect an earth-bonding cable to the grounding connection provided at the outside of the remote unit (see chapter 4.2.2 Connections). Do not use the grounding connection to connect external devices.



B0208A2A

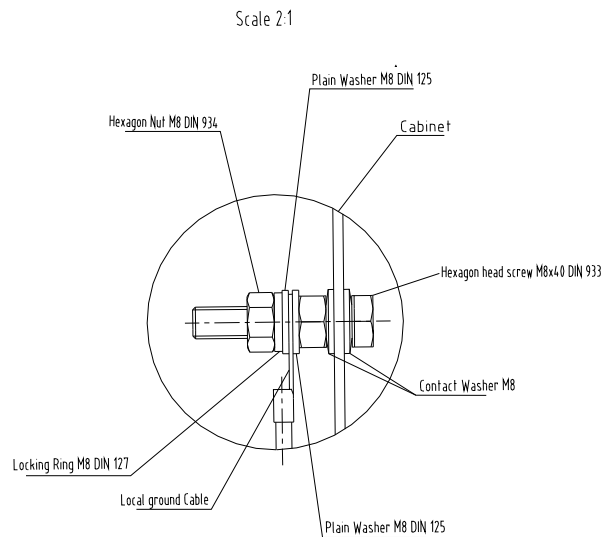

figure 4-4 Grounding bolt

After loosening the hex nut, connect the earth-bonding cable between the two washers as illustrated in the figure above. Then, fasten all parts again with the hex nut.



The PE cables must have a minimum cross section of 16mm².

4.2.4. Power Connection

Before connecting electrical power to the units, the system must be grounded as described in the previous chapter.

Mains power must be connected at the mains connector of the unit (see chapter 4.2.2 *Connections*).

The power supply plug is part of the delivery. The correct wiring of the power supply plug is as follows:

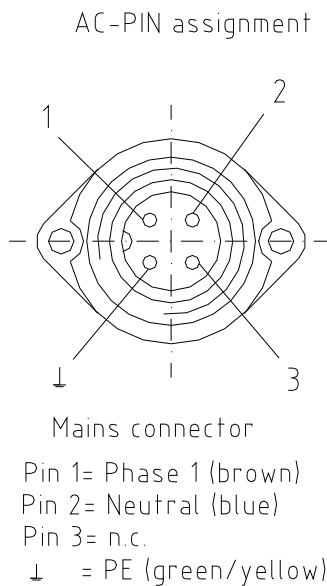

G1038Z0

figure 4-5 AC mains plug

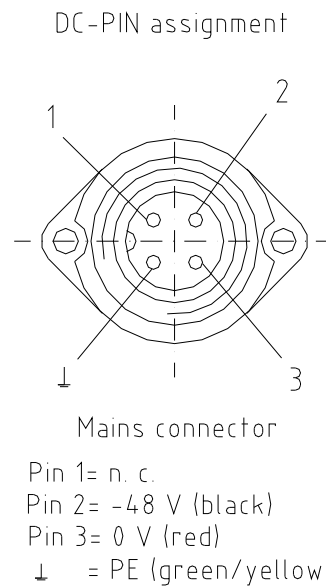

G1038Z0

figure 4-6 DC mains plug



For the AC power supply connection, a minimum cross section of 1.5 mm² is required and for the DC power supply connection, a minimum cross section of 2.5 mm² is required. Each wire must observe the applicable national regulations regarding loop impedance, voltage drop, and methods of installation. Make sure to connect the correct voltage to the unit.

 **Note:** Do not connect or disconnect the power cord at the mains connector while power is on. Turn off mains * power before connecting the power cord at the remote unit, then, engage mains again.

* Mains power must be interrupted with an external mains breaker. For the mains breaker, observe the following recommendation:

120 Volt / 20 Amp max. or 240 Volt / 16 Amp, single-phase, 50 / 60 Hz AC service is needed, i.e. the external AC breaker should be 20 Amps max. for 120-Volt service or 16 Amps for 240-Volt service.

For the DC power supply, observe the local regulations of the DC service provider.

4.3. CONNECTION OF THE ANTENNA CABLES

The Main Unit has N connectors. For its location, please refer to chapter 4.2.2 *Connections*. However, the Combining Unit has 7/16 antenna connectors (described in separate manual). For mounting the cable connectors, it is recommended to refer to the corresponding documentation of the connector manufacturer. The bending radius of the antenna cables must remain within the given specifications.

For the selection of cable and antenna it should be considered that, on the one hand, a cable with higher loss is less expensive but, on the other hand, it impairs performance.



It is sufficient to tighten the 7/16 antenna connectors of the Combining Unit hand-tight. The use of a tool (like pliers) may cause damage to the connector and, therefore, lead to a malfunctioning of the remote unit.

4.4. CONNECTION OF THE RF CABLES MAIN UNIT TO COMBINING UNIT

To connect RF cables to Combining Unit, connect corresponding ports according to frequency as labelled. For orientation of the location of connectors please refer to the illustrations of Main Unit in chapter 4.2.2 *Connections* and/ or of Combining Unit in chapter 5.6 *Redundancy Relay Configuration*.

4.5. OPTICAL-FIBRE-CABLE CONNECTION - RULES

Optical signals are transmitted by use of optical fibres. When connecting these fibres observe the following instructions.

 **Note:** Care should be taken when connecting and disconnecting fibre-optic cables. Scratches and dust significantly affect system performance and may permanently damage the connector. Always use protective caps on fibre-optic connectors not in use.

In general, optical fibres do not need special protective measures. However, protection against environmental influences e.g. rodents and humidity must be considered.

The optical fibre is a single-mode fibre. Type is E9/125 μm with the following minimum requirements.

Attenuation: <0.36 dB / km @ 1310 nm / <0.26 dB / km @ 1550 nm
Dispersion: <3.5 ps / nm km @ 1310 nm / <18.0 ps / nm km @ 1550 nm

The specified bending radius of the optical fibres must not be exceeded. The pigtails for the connection between mini master and remote unit must have a sufficient length. A protection for the feeding into units must be given. For ION-M7P/8P S, the system attenuation of the optical fibres, including the connectors, must not exceed 10 dB.

System attenuation and attenuation of optical components must be determined. This can be achieved by measuring attenuation and reflection with an appropriate measuring instrument. For pigtails, a total value of < 0.4 dB (measured to a reference plug) can be assumed due to the dead zone of the reflectometer. These measurements must be made with a sufficient length of optical fibre, at the input and output of the device which has to be measured.

Fibre-cable connectors have to be of the same type (E2000APC) as the connectors used for the unit. The fibre-optic cables are connected to the optical transceiver.



Angled connectors are not compatible with straight optical connectors; non-compatibility of connectors will result in permanent damage to both connectors.

Before connecting the fibre cables, follow the procedure below to ensure optimized performance. It is important for these procedures to be carried out with care:

- Remove fibre-optic protective caps.
- Do not bend the fibre-optic cable in a tight radius (< 4 cm) as this may cause cable damage and interrupt transmission.
- Using high-grade alcohol and lint-free cotton cleaning swabs, clean the end of the fibre-optic cable that will be inserted in the optical connectors on the donor interface box.
- Blow out the laser receptacle with clean and dry compressed air to remove any particulate matter.
- Connect the fibre-optic cables by inserting the cable end into the laser receptacle and aligning the key (on the cable end) with the keyed slot.
- Do not use any index matching gels or fluids of any kind in these connectors. Gels are intended for laboratory use and attract dirt in the field.

4.5.1. Protective Plug

Connection:

A protective plug is provided for the connection of the fibre-optic cables.

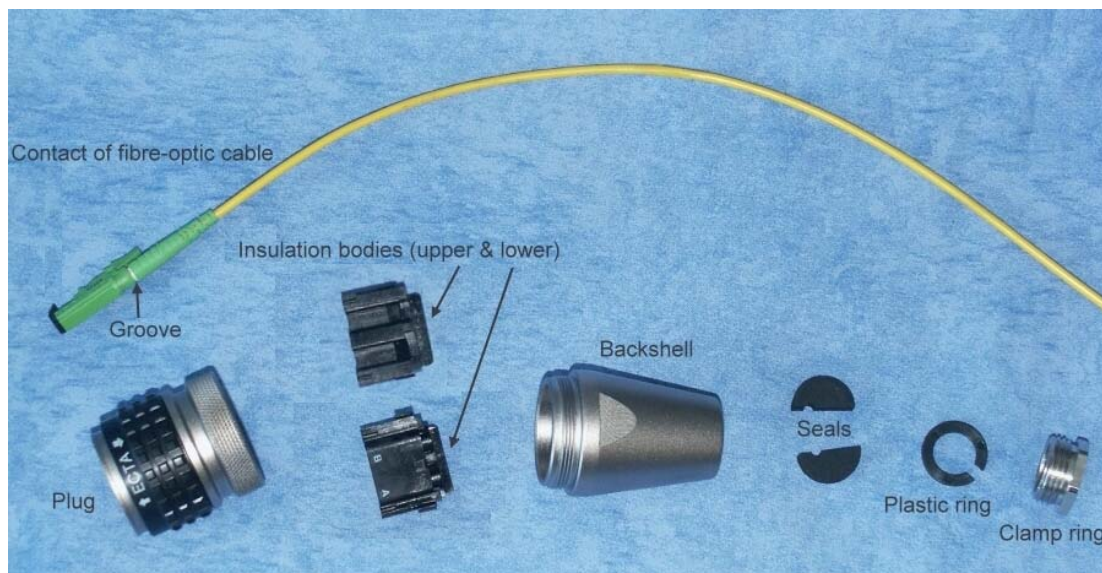

B0122AMA

figure 4-7 Protective-plug assembly

Note: Only high-quality connectors must be used for this type of plug. Qualified brands are Diamond or Huber & Suhner.

For plug assembly, observe the following instruction:

1. Pass one or two contacts through the backshell and the clamp ring.



B0122A1A

2. Place the contact(s) on the lower insulation body by pushing the groove of the contact into the cavity. If there is only one contact, cavity A **must** be used. *
3. Then, mount the upper insulation body on the lower insulation body. **



Upper insulation body

B0122A4A

4. Bring the insulator into the plug. The narrow groove of the insulator must be fitted into the stamp of the plug.

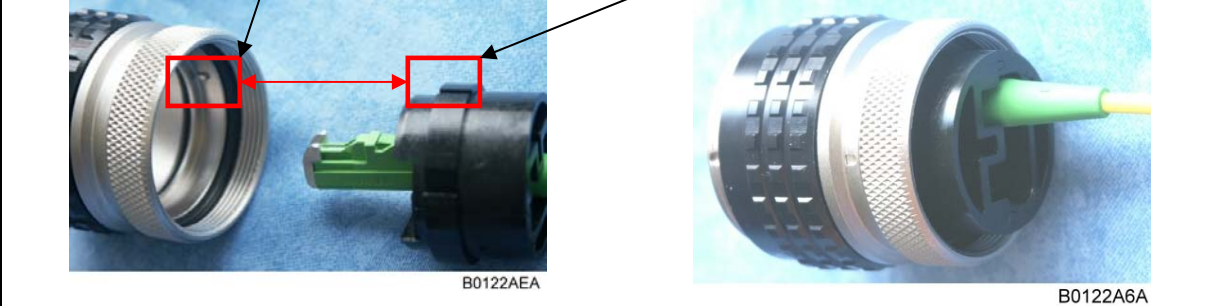

B0122A6A

* To release the contact for disassembling, push the inner snap to the side and pull the contact out.

** To release upper and lower insulation bodies for disassembling, use a small screwdriver and carefully open the snap-connections at the left and the right side of the insulator without damaging them.

5. Fasten the insulator by screwing the backshell tight onto it. Use a spanner with opening 32 to screw the backshell tight (no gap).

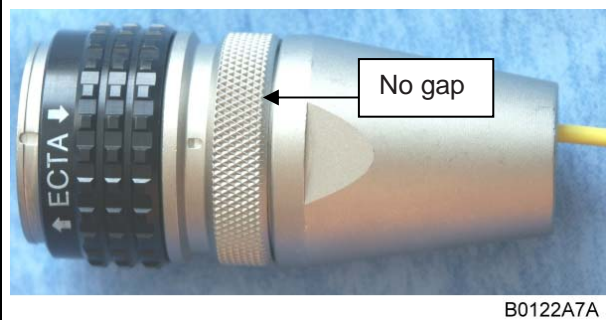

No gap

B0122A7A

6. Place the appropriate seal parts (with one groove for one contact or two grooves for two contacts) over the cable(s) and push them into the backshell.

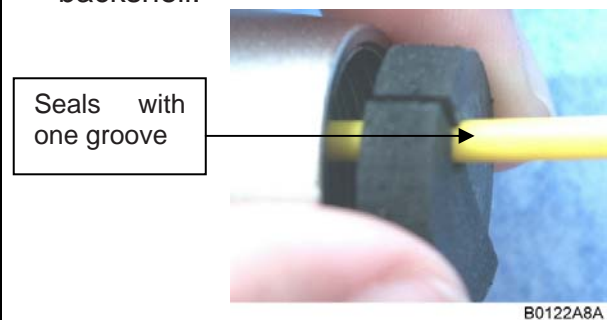

Seals with one groove

B0122A8A

7. Bring the plastic ring over the cable(s), push it into the backshell and compress the seals and plastic ring by screwing the clamp ring tight (no gap) using a spanner with opening 20. ***

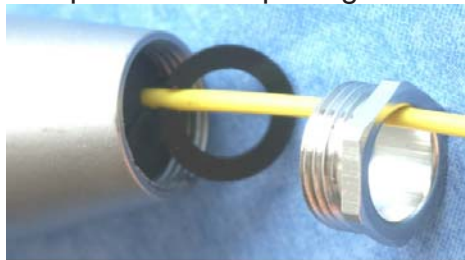

B0122A9A

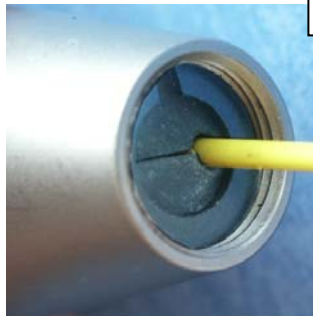

B0122AAA

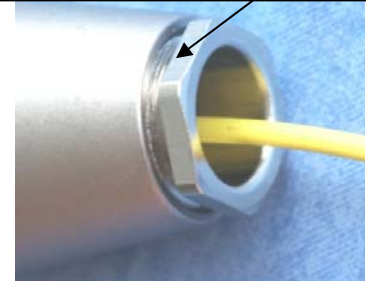

B0122ABA

8. Connect the plug to the optical-fibre connector of the remote unit, again by fitting a stamp on the plug into the groove of the connector.

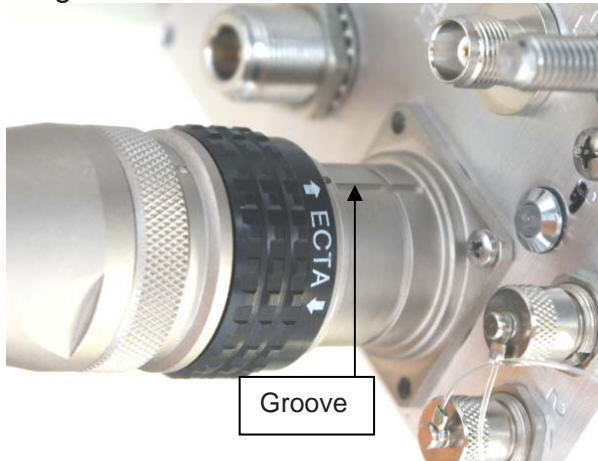

B0122ACA

9. To lock the connector, push the black locking ring forward. ****



B0122ADA

*** For disassembling, release the clamping ring and remove the seals and the plastic ring first.

**** Locking mechanism: The system of locking the plug is based on a “push-pull” mechanism. The locking ring has to be pushed forward to lock the connector and pulled back to free the connection.

4.5.2. Protective-Tube Kit

As additional protection for the optical fibres, this connector type can be supplemented by a special tube kit. To fasten the tube correctly, first unscrew the clamp ring (if already installed) of the original plug kit.

Then, proceed according to the following instruction:

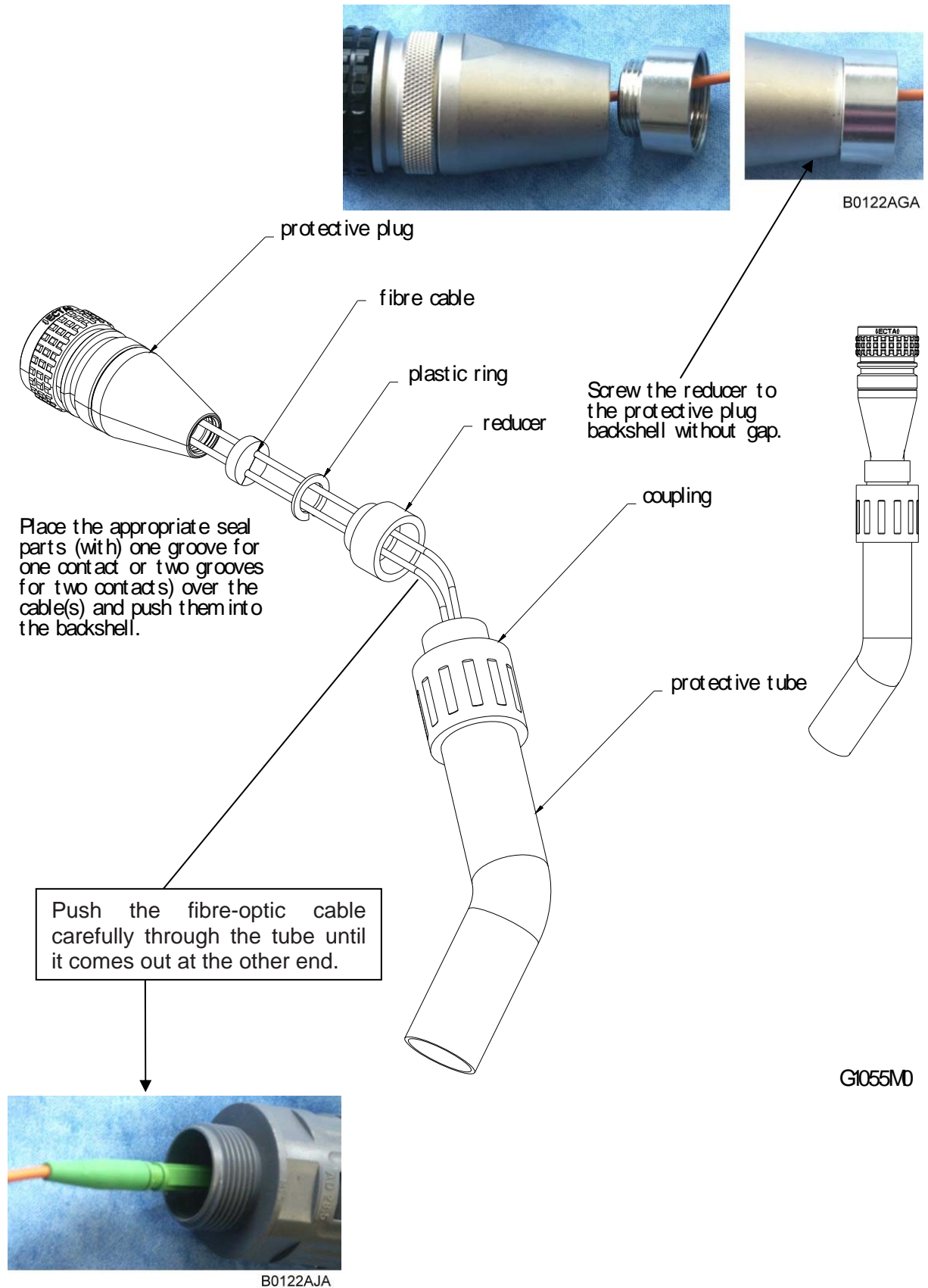

figure 4-8 Tube-kit installation

4.6. COMMISSIONING

Read the health and safety warnings in chapter *1.2 Health and Safety Warnings* as well as the description carefully to avoid mistakes and proceed step by step as described!

Do not operate the remote unit without terminating the antenna connectors. The antenna connectors may be terminated by connecting them to their respective antennas or to a dummy load.

Only qualified personnel should carry out the electrical, mechanical, commissioning and maintenance activities that require the unit to be powered on when open.

When opening the remote unit do not damage the warranty labels on the internal devices. The warranty is void if the seals are broken.

Ensure that all connections have been performed according to chapter *4.2 Electrical Installation*.

Commissioning an ION-M Remote Unit

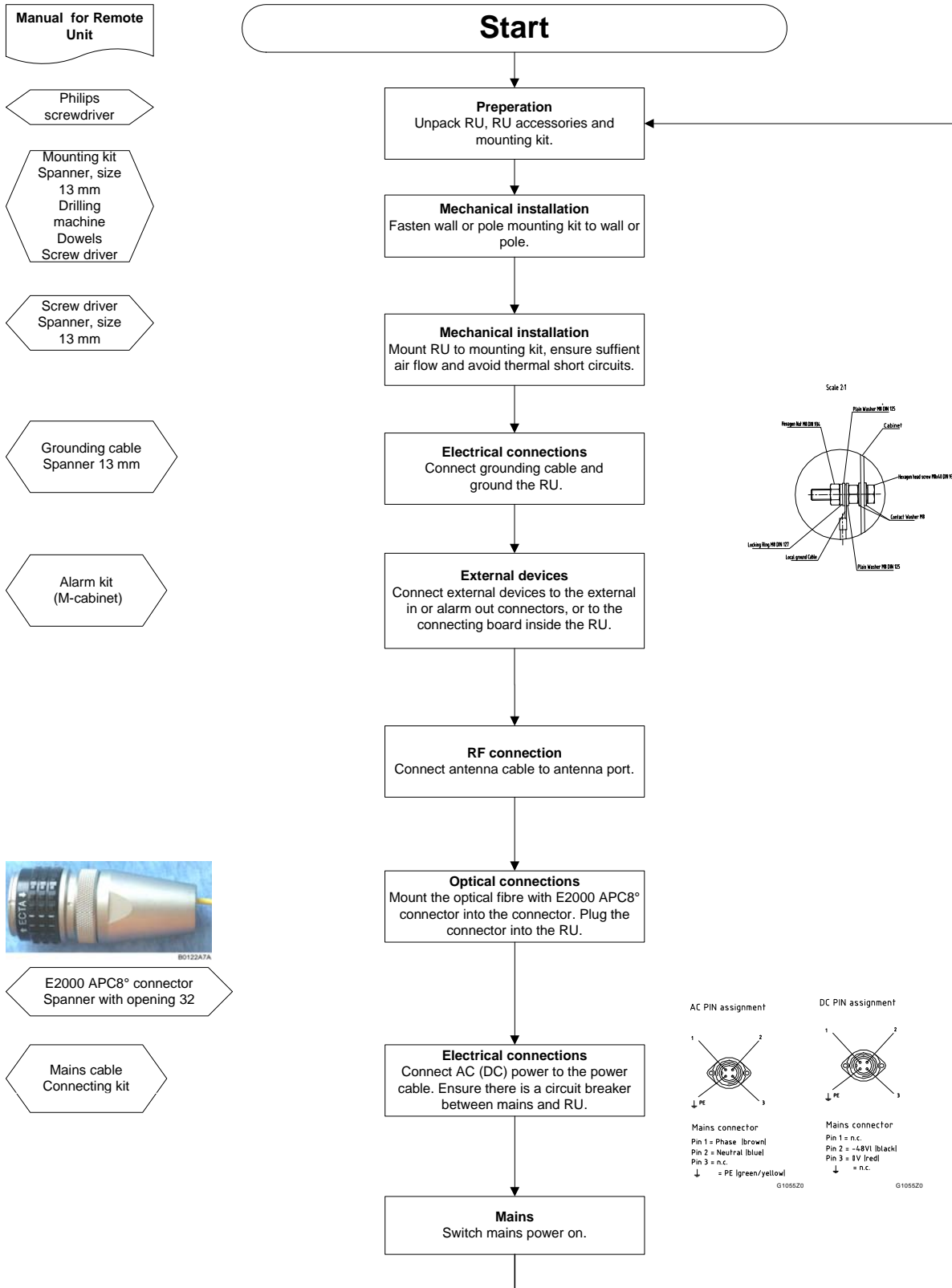

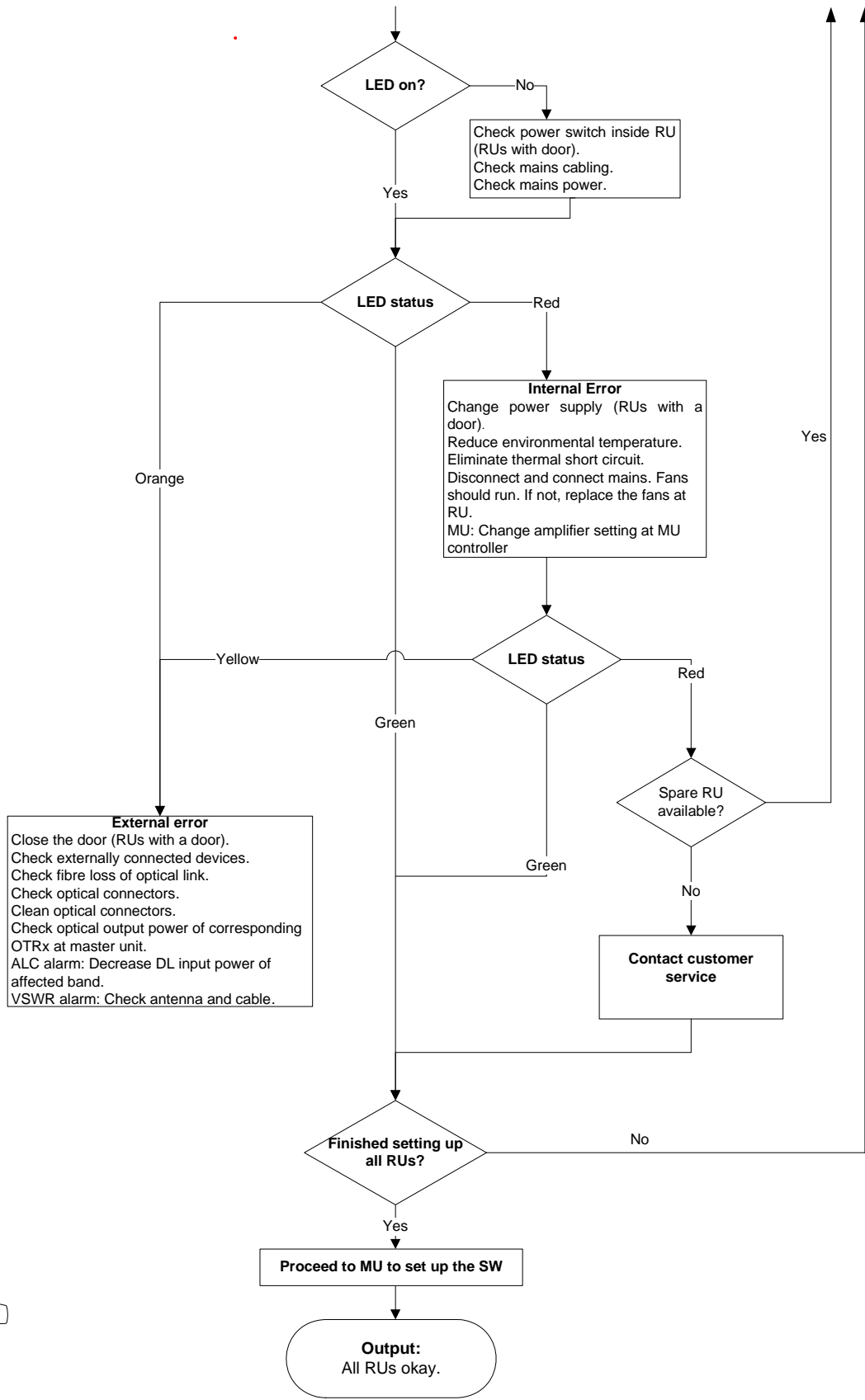

5. ALARMS

5.1. BITE AND ALARMS

The Built-In Test concept comprises the monitoring of the power supplies, the power amplifiers and the optical interface.

All occurring alarms can be checked via software at the master unit.

5.2. HANDLING OF ALARMS

As soon as the software acknowledges a valid alarm, a message is transmitted to the master unit.

If the reason for the alarm has been cleared or if the alarm should continue, a new alarm message will not be repeated. If there was an interruption of at least five seconds after acknowledgement, a new alarm message will be generated.

5.3. ALARM STATUS

For details refer to the corresponding software documentation of the master unit.

5.4. STATUS LED ALARMS

For local supervision, a status LED on the connector flange of the remote unit gives an indication of possible reasons for alarms. The position of the status LED is illustrated in chapter 4.2.2 *Connections*. This table shows possible on-site measures that could be checked before referring to the master unit alarm list.

Status LED indication	Alarms	Possible on-site measures
Green	No alarm → Status ok	
Orange	Door alarm	Close the door (RUs with door).
	<i>Alarms not directly related to RU:</i>	
	External alarms	Check externally connected devices.
	Optical alarm Rx	Check fibre loss of optical link. Check optical connectors. Clean optical connectors. <i>(MU: Check optical output power of corresponding OTRx at master unit).</i>
	ALC alarm	<i>(MU: Decrease DL input power of affected band).</i>

Status LED indication	Alarms	Possible on-site measures
Red	<i>Alarms directly related to RU:</i>	
	Power 28 V	Change power supply (RUs with door). Replace the affected remote unit.
	Temperature	Reduce environmental temperature. Eliminate thermal short circuit.
	Fan *	Disconnect and connect mains. Fans should run. If not, replace the fans at RU.
	I ² C	Disconnect and connect mains.
	Optical alarm Tx	-
	Amplifier "Power Down"	<i>(MU: Change amplifier setting at MU controller).</i>
Status LED off	Mains	Check power switch inside of RU (RUs with door). Check mains cabling. Check mains power.

table 5-1 Status LED alarms

* only applicable if the RU is equipped with a fan

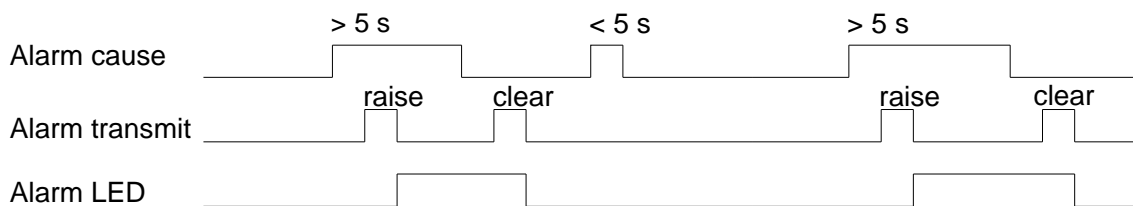

V1651A2

figure 5-1 Alarm triggering

For the position of the LED see chapter 4.2.2 *Connections*.

Explicit troubleshooting is available in the MU software, (software manual or WEB Interface).

5.5. RELAY ALARM CONNECTING BOARD

5.5.1. External-Alarm Inputs and Outputs

There are four alarm inputs and four alarm outputs. The alarm outputs are potential-free relay contacts. They can be used to monitor alarms with an external-alarm indicator. Each alarm output can be set individually to any alarm at the remote unit. For details please refer to the according chapter in the software manual of the master unit.

 **Note:** **The manufacturer / supplier of this system accepts no liability for damage caused by equipment connected to external outputs or by effects from such equipment.**

With the external-alarm inputs, it is possible to monitor the status of connected devices, e.g. a UPS, via software. All alarm inputs are normally high (5 V) without connection.

The device to be monitored must be connected so that the alarm contacts will be closed in case of an alarm (maximum switching power of 28 Vdc, 0.5 A).

The location of the external-alarm inputs and outputs is illustrated in the following chapter *5.5.2 Layout and Connector Description*. Settings have to be done via the ION-M Master Controller and are described in the according software documentation.

Please note that at the remote unit (RU), the alarm ground of the external-alarm inputs is linked with the ground at the RU.

5.5.2. Layout and Connector Description

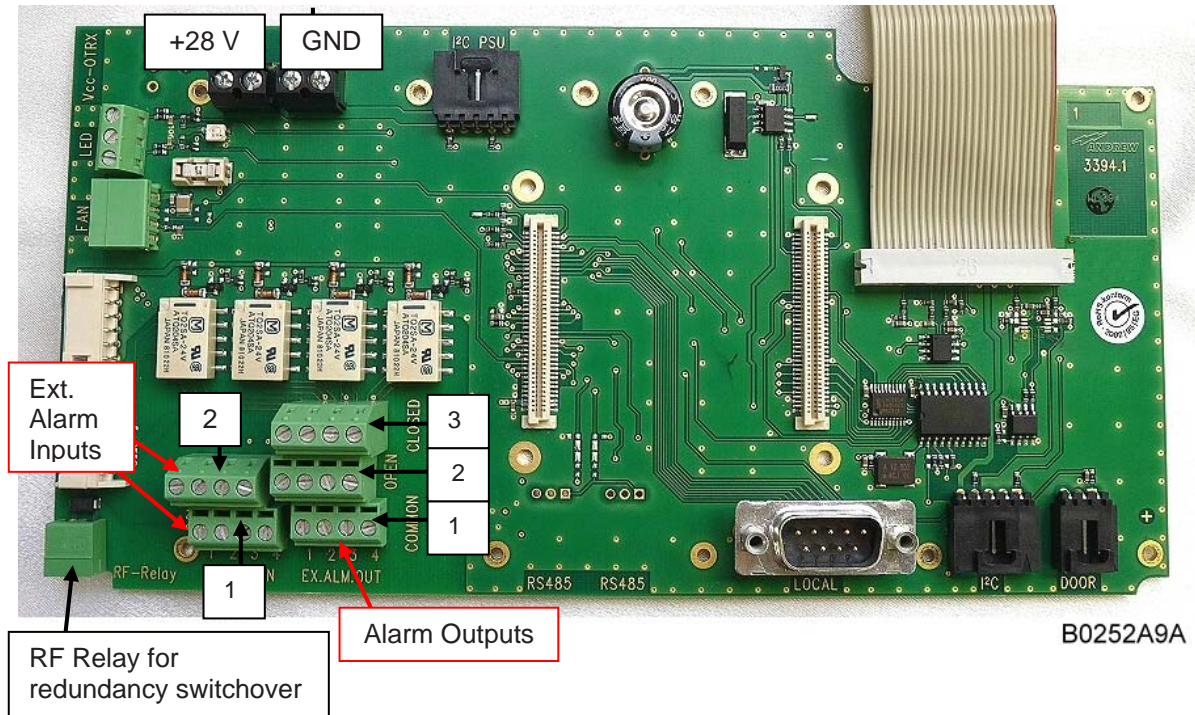

figure 5-2 Relay alarm connecting board, description of connectors

Connector	PIN	Description
Ext. Alarm INPUTS * 1	1	Ext. Alarm 1 Common
	2	Ext. Alarm 2 Common
	3	Ext. Alarm 3 Common
	4	Ext. Alarm 4 Common

* Voltage: 0 - 5 V; Current: max. 7 mA (each input)

Connector	PIN	Description
Ext. Alarm INPUTS * 2	1	Ext. Alarm IN 1
	2	Ext. Alarm IN 2
	3	Ext. Alarm IN 3
	4	Ext. Alarm IN 4

* Voltage: 0 - 5 V; Current: max. 7 mA (each input)

Connector	PIN	Description
Alarm OUTPUTS 1	1	Alarm OUT 1 Common
	2	Alarm OUT 2 Common
	3	Alarm OUT 3 Common
	4	Alarm OUT 4 Common

Connector	PIN	Description
Alarm OUTPUTS 2	1	Alarm OUT 1 Open
	2	Alarm OUT 2 Open
	3	Alarm OUT 3 Open
	4	Alarm OUT 4 Open

Alarm OUTPUTS 3	1	Alarm OUT 1 Closed
	2	Alarm OUT 2 Closed
	3	Alarm OUT 3 Closed
	4	Alarm OUT 4 Closed

table 5-2 Relay alarm connecting board connectors, pin assignment

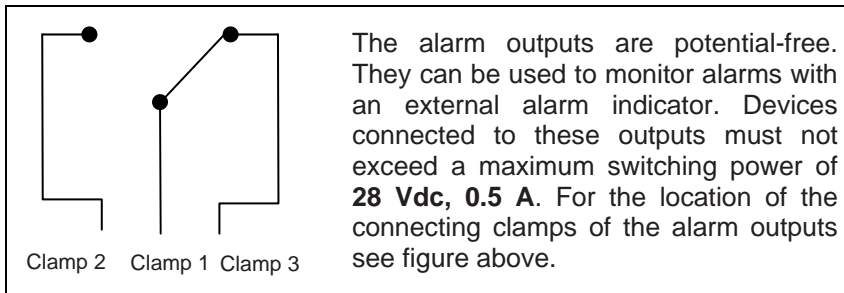

figure 5-3 Alarm-output contacts, alarm condition

5.6. REDUNDANCY RELAY CONFIGURATION

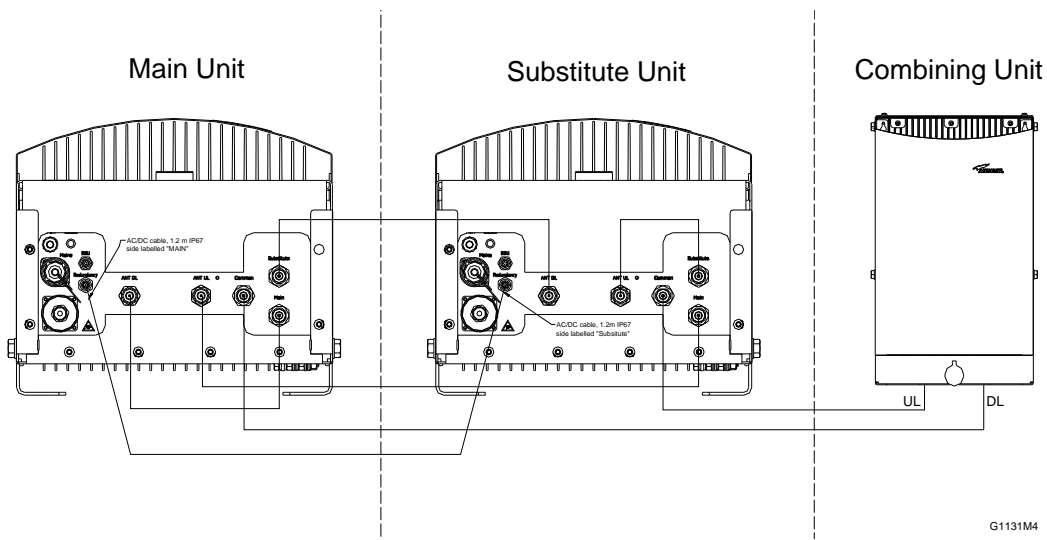

figure 5-4 Redundancy connection, cabling

Note: The Combining Unit illustrated above is not part of this delivery.

Redundancy Relay – Description

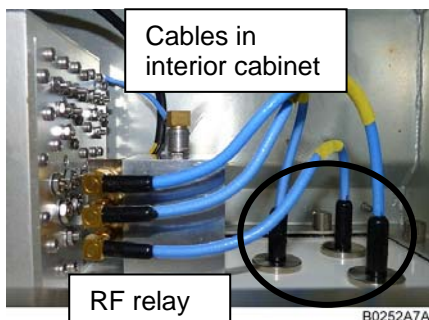

figure 5-5 Redundancy RF relay

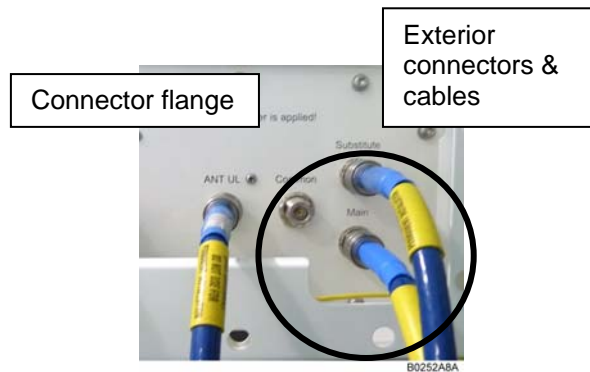

figure 5-6 Redundancy connectors, Main Unit and Substitute Unit

Via the redundancy relay (see illustration below), signals are switched from the Main Unit to the Substitute Unit in case an alarm raise appears in the main unit. Alarms that shall switch service to Substitute Unit in alarm condition can be selected via web interface, see description in separate software manual.

☞ **Note:** When the redundancy option is used, External Alarm IN 1, Alarm OUT 1 and Alarm OUT 2 are not available.

5.7. TROUBLESHOOTING

The status of the remote unit can be checked via the master unit (for details please refer to the software manual of the Master Controller). Locally, the status can be checked at the LED, see chapter *4.2.2 Connections*.

6. MAINTENANCE

6.1. GENERAL

Read the health and safety warnings in chapter *1.2 Health and Safety Warnings*.

Note: The remote unit does not require preventative maintenance measures.

Maintenance of the ION-M7P/8P S should be performed on a FRU (Field Replaceable Unit) basis only. Do not damage the warranty labels on the components, as this voids the warranty.

The spare parts list contains only units that can be replaced without tuning or soldering work.

Note: When sending back the unit, use an appropriate packaging. We strongly recommend using the original packaging!

Note: Defect parts should only be replaced by original parts from the supplier. All interventions inside the housing are at one's own risk.

Note: During maintenance ensure that the unit has been disconnected from mains.

Note: Before disconnecting any cables, label any unlabelled cables to ensure correct reconnection.

To replace an FRU, use the appropriate tools. Replacement tools may be ordered from the supplier. All screws have a right-hand thread, turn the tool clockwise for tightening and counter-clockwise for loosening.

SMA connectors have a specified torque of 100 Ncm. Use an appropriate tool to fasten and unfasten these connectors. Do not over-tighten the connectors or screws. The table below shows various screws with their respective torques.

Screw Type	Tallow-drop	Socket-head-cap	Countersunk-head
<i>Thread size</i>	<i>Specified Torque (in Ncm)</i>		
M 2.0	40	not in use	40
M 2.5	82	not in use	82
M 3.0	145	100	145
M 4.0	330	330	330
M 5.0	650	tbd.	650

table 6-1 Specified torques for various screw types

If any FRU not contained in the following chapter needs to be replaced, contact customer service for additional instructions.

6.2. OPENING AND CLOSING OF THE CABINET

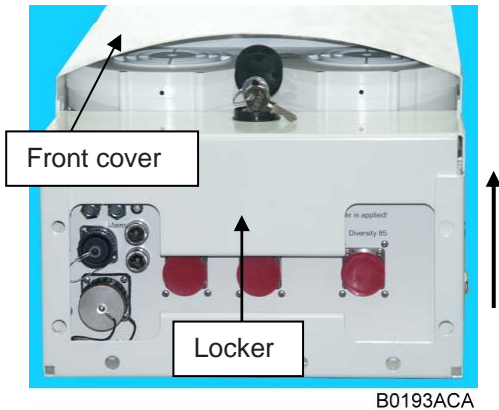

figure 6-1 Locker with key

Before opening the cabinet of the unit, observe the instructions in chapter 4.1.1 *General*.

To open the cabinet of the remote unit, first dismount the locker by unlocking it with the key (which is part of the delivery) and pulling it out carefully in direction of the arrow marked in figure 6-1 *Locker with key*.

If the front cover is installed (see mechanical installation in chapter 4.1.1 *General*) remove the cover by loosening the four M5 socket head cap screws (circle-marked in figure 6-2 *Front and top cover screws*). Do **not** remove those screws. When they are loosened, the front cover can be taken off.



figure 6-2 Front and top cover screws

Before opening the cabinet, disconnect the mains connector illustrated in chapter 4.2.2 *Connections*.

To open the cabinet, unscrew the nine M5 socket head cap screws (captive) of the top cover of the remote unit (see figure 6-2 *Front and top cover screws*).

After maintenance work, re-connect mains.

Close the cabinet.

To ensure safe operation, mount the front cover if required (see mechanical installation in chapter 4.1.1 *General*).

Check the status of the status LED. Ensure it is showing a green light.

6.3. REPLACEMENT OF POWER SUPPLY

To remove the power supply, disconnect mains, mains cable and DC cable.

Unscrew the five hexagon socket head cap screws (circle-marked in illustration below) with an Allen key.

Pull the power supply out.

Apply heat-conducting paste to the mounting surface of the new power supply.

Carefully insert the new power supply.

Fasten the five socket head cap screws.

Re-connect all cables.



B0200A5A

figure 6-3 Power supply screws

6.4. REPLACEMENT OF FAN UNIT

The fan unit is an FRU in the ION-M7P/8P S.



B0193A5A

figure 6-4 Fan unit screws

Unscrew the three M5x16 socket-head screws by which the fan unit is screwed to the cabinet. Be careful not to lose the according washers.

Take off the fan unit and disconnect the connector cable from the cabinet.



B0185A3A



B0185A2A

To install the new fan unit, proceed in reverse order.

In order not to squeeze the fan connector cable, take care to position it correctly after its re-connection.



B0185A4A



B0185A5A

figure 6-5 Fan-connector cable

7. APPENDIX

7.1. LAYOUT

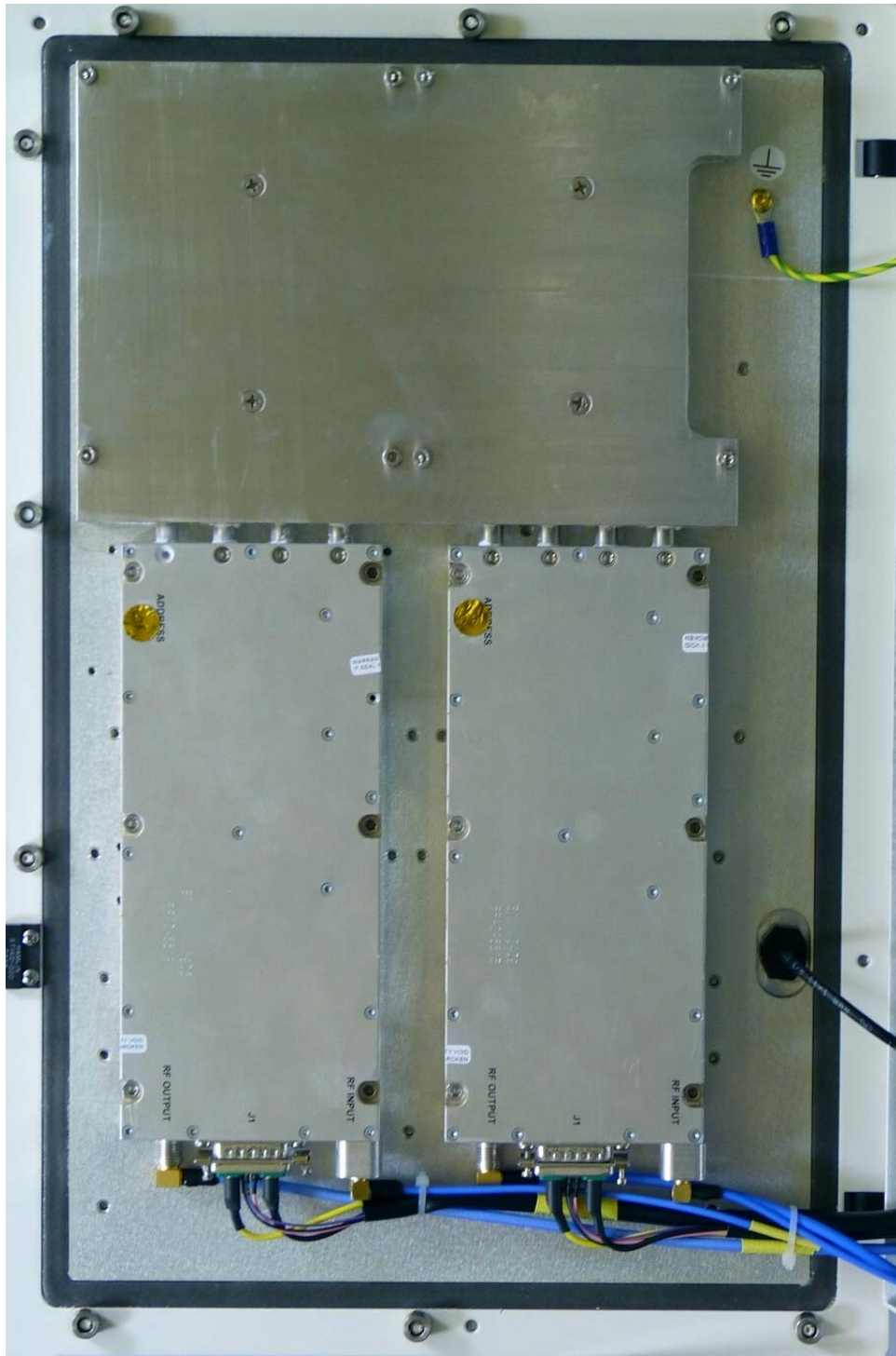

B0252A5A

figure 7-1 Layout of ION-M7P/8P S, lid

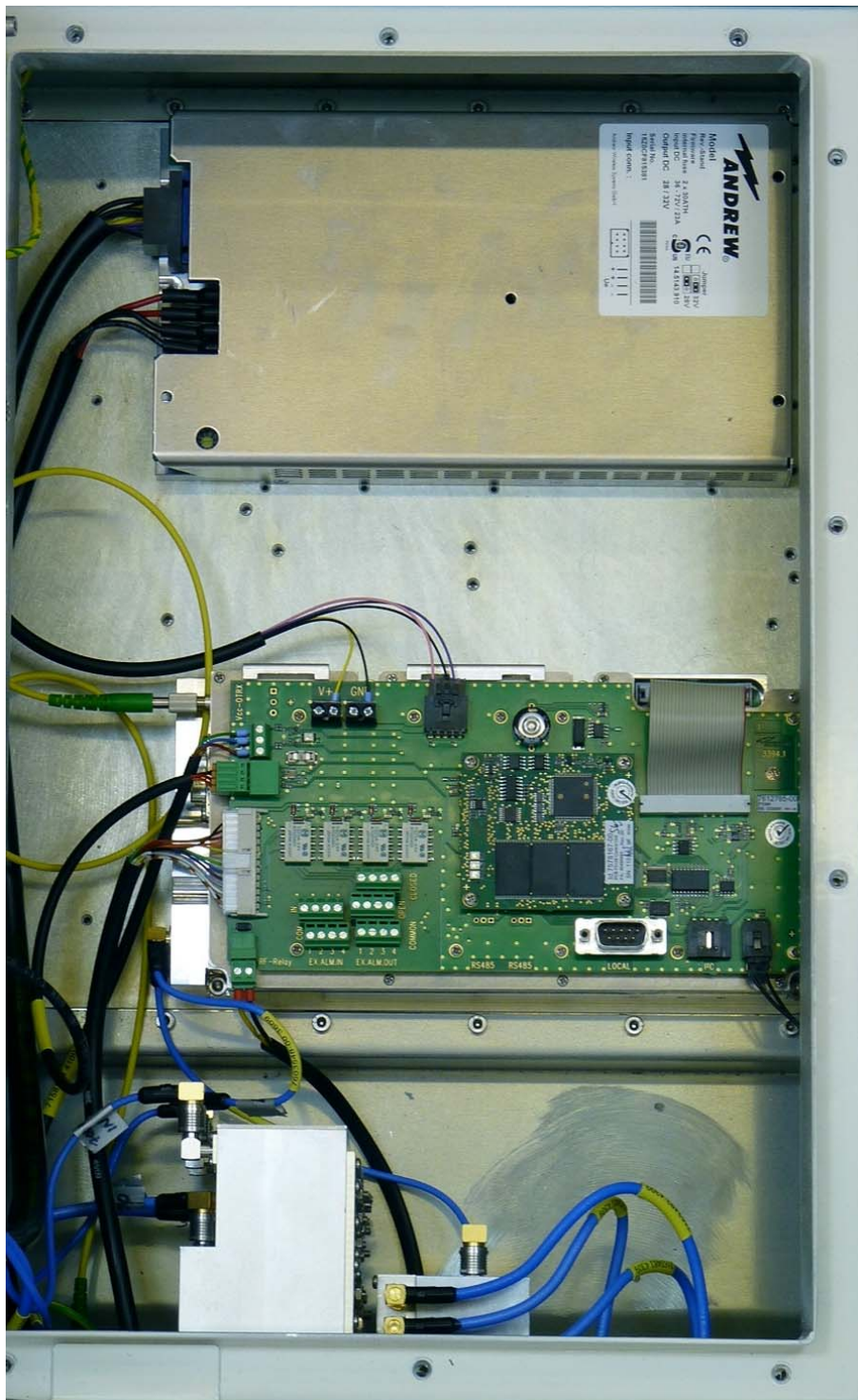

B0252A6A

figure 7-2 Layout of ION-M7P/8P S, base

7.2. SPECIFICATIONS

Detailed ION-M7P/8PS product specifications are available upon request.

8. INDEX

A		H	
Abbreviations.....	7	Health and Safety Warnings.....	9
Address of Andrew Wireless Systems GmbH.....	13	I	
Alarms		Installation	
Alarm Status	33	Electrical	21
Bite and Alarms	33	Mechanical	19
External.....	35	L	
Handling of Alarms	33	Layout - Base	44
List	38	Layout - Lid.....	43
Outputs	35	LED	33
RU	38	M	
Status LED.....	33	Maintenance.....	39
Andrew Solutions.....	11	Mounting	
B		General.....	19
Block Diagram	17	Wall.....	20
C		O	
Commissioning		Opening and Closing the Cabinet.....	40
General.....	30	Optical-Fibre Connection	
Components		Protective Plug	26
Interior	18	Protective-Tube Kit	28
Connecting Board		Optional Equipment	
with Relays	35, 36	Relay Alarm Connecting Board	18
Connection Rules		P	
Optical Fibres.....	25	Power Supply	
Optical-Fibre Cables	25	Replacement	41
Connections		R	
Antenna Cables	24	Redundancy Relay Configuration.....	37
Connector Flange	22	Relay Alarm Connecting Board	
Optical-Fibre Cables	25	Output Connectors.....	36
Power	23	Relay Alarm Connecting Board	35
RF Cables MU to CU	24	Alarm Outputs.....	36
Contact Addresses	12	Alarm-Output Contacts	36
Customer Support Addresses.....	12	External-Alarm Inputs and Outputs.....	35
D		External-PSU Connector	36
Declaration of Conformity	11	Input Connectors	36
F		Replacement of	
Fan Connector Cable	42	Fan Unit	42
Fan Unit		Power Supply	41
Replacement.....	42	T	
Screws.....	42	Troubleshooting.....	38
G			
General.....	40		
Grounding.....	22		

