

Optical Remote Unit ION[®]-M7P/80-85HP/9



(W2-Cabinet)

**Manual
MF0145APA**

© Copyright 2013 CommScope, Inc.

All rights reserved.

All information contained in this manual has been revised thoroughly. Yet CommScope accepts no liability for any omissions or faults.

CommScope reserves the right to change all hardware and software characteristics without notice.

Names of products mentioned herein are used for identification purposes only and may be trademarks and / or registered trademarks of their respective companies.

No parts of this publication may be reproduced, stored in a retrieval system, transmitted in any form or by any means, electronical, mechanical photocopying, recording or otherwise, without prior written permission of the publisher.

Andrew Wireless Systems GmbH, 10-October-2013

TABLE OF CONTENTS

1. GENERAL	5
1.1. USED ABBREVIATIONS	5
1.2. HEALTH AND SAFETY WARNINGS	6
1.3. ABOUT COMMSCOPE	9
1.4. INTERNATIONAL CONTACT ADDRESSES FOR CUSTOMER SUPPORT	10
2. INTRODUCTION	13
2.1. PURPOSE	13
2.2. THE ION-M7P/80-85HP/9 (INTELLIGENT OPTICAL NETWORK; MMR)	13
3. COMMISSIONING	15
3.1. MECHANICAL INSTALLATION	15
3.1.1. General	15
3.1.2. Wall-Mounting Procedure	17
3.2. ELECTRICAL INSTALLATION	18
3.2.1. General	18
3.2.2. Connections	19
3.2.3. Grounding	20
3.2.4. Connection of the Extension Unit	21
3.2.5. Connection of the Antenna Cables	21
3.2.6. Power Connection	22
3.3. OPTICAL-FIBRE-CABLE CONNECTION - RULES	23
3.3.1. Protective Plug	25
3.3.2. Protective-Tube Kit	27
3.4. COMMISSIONING	29
4. ALARMS	32
4.1. BITE AND ALARMS	32
4.2. HANDLING OF ALARMS	32
4.3. ALARM STATUS	32
4.4. STATUS LED ALARMS	32
4.5. EXTERNAL ALARM INPUTS AND OUTPUTS	33
4.6. TROUBLESHOOTING	35
5. MAINTENANCE	35
5.1. GENERAL	35
5.2. REPLACING THE FAN UNIT	36
5.3. CLEANING THE HEAT SINK	38

6. APPENDIX	39
6.1. ILLUSTRATIONS	39
6.2. SPECIFICATIONS	40
6.2.1. Electrical Specifications	40
6.2.2. Mechanical Specifications	40
6.2.3. Environmental and Safety Specifications	40
6.3. SPARE PARTS	41
7. INDEX	42

FIGURES AND TABLES

figure 3-1 Wall mounting.....	17
figure 3-2 Connector flange of ION-M7P/80-85HP/9	19
figure 3-3 RS485 connector.....	20
figure 3-4 Grounding bolt, schematic view	20
figure 3-5 Extension-port connector	21
figure 3-6 Power supply plug to RU Mains connector	22
figure 3-7 Protective-plug assembly	25
figure 3-8 Tube-kit installation	28
figure 4-1 Flange connector, 5 poles.....	33
figure 4-2 Flange connector, 7 poles.....	33
figure 4-3 Alarm inputs and outputs, standard	34
figure 6-1 Cabinet drawing	39
table 1-1 List of international contact addresses.....	12
table 3-1 Specified torques.....	16
table 3-2 RS485 connector, pin assignment	20
table 3-3 Extension-port connector, pin assignment	21
table 4-1 Status LED alarms.....	33

1. GENERAL

1.1. USED ABBREVIATIONS

3GPP	3 rd Generation Partnership Project
AC/DC	Alternating current / Direct Current
ALC	Automatic Level Control
BITE	Built-In Test Equipment
BTS	Base Transceiver Station
CE	"Conformité Européenne" ("European Conformity")
CD	Compact Disk
CFR	Code of Federal Regulations
DL	Downlink
DoC	Declaration of Conformity
EDGE	Enhanced Data Rates for GSM Evolution
EN	European Norm
EP	Extension Port
ESD	Electrostatic Discharge
ETS	European Telecommunication Standard
EU	Extension Unit
GSM	Global System for Mobile Communication
GND	Ground
GUI	Graphical User Interface
ICP3	Intercept Point 3rd order
ID No	Identification Number
ION	Intelligent Optical Network
IP	Ingress Protection
ISO	International Organization for Standardization
LED	Light Emitting Diode
LMT	Local Maintenance Terminal
LTE	Long Term Evolution
MIMO	Multiple Input Multiple Output
MS	Mobile Station
MU	Main Unit
NF	Noise Figure
OTRx	Optical Transceiver = SRMU (Subrack Master Unit)
PG	Packing Gland
PIM	Passive Intermodulation
P_{in}	Input power
P_{out}	Output power
R&TTE	Radio & Telecommunications Terminal Equipment
RF	Radio Frequency
RU	Remote Unit
RX	Receiver
SNMP	Simple Network Management Protocol
TS	Technical Specification
TX	Transmitter
UL	Uplink
UMTS	Universal Mobile Telecommunication System
UPS	Uninterruptible Power Supply
WCDMA	Wideband Code Division Multiple Access
WDM	Wavelength Division Multiplex

1.2. HEALTH AND SAFETY WARNINGS



1. **Danger:** Obey all general and regional installation and safety regulations relating to work on high voltage installations, as well as regulations covering correct use of tools and personal protective equipment.

2. **Danger:** Before opening the unit, disconnect mains power.



3. **Danger:** Laser radiation! Do not stare into the beam; do not view it directly or with optical instruments.

4. **Danger:** Due to power dissipation, the remote unit may reach a very high temperature. Do not operate this equipment on or close to flammable materials. Use caution when servicing the unit.

5. **Warning:** Read and obey all the warning labels attached to the unit. Make sure that all warning labels are kept in a legible condition. Replace any missing or damaged labels.

6. **Warning:** It is the responsibility of the network provider to implement prevention measures to avoid health hazards associated with radiation from the antenna(s) connected to the unit.

7. **Warning:** Only authorized and trained personnel are allowed to open the unit and get access to the inside.

8. **Warning:** Only license holders for the respective frequency range are allowed to operate this unit.

9. **Warning:** Make sure the repeater settings are correct for the intended use (refer to the manufacturer product information) and regulatory requirements are met.

10. **Warning:** Use this equipment only for the purpose specified by the manufacturer. Do not carry out any modifications or fit any spare parts, which are not sold or recommended by the manufacturer. This could cause fires, electric shock, or other injuries.

11. **Warning:** For installations which have to comply with European EN50385 exposure compliance requirements, the following Power Density limits/guidelines (mW/cm²) according to ICNIRP are valid:

- 0.2 for frequencies from 10 MHz to 400 MHz
- $F \text{ (MHz)} / 2000$ for frequencies from 400 MHz to 2 GHz
- 1 for frequencies from 2 GHz to 300 GHz

12. **Warning:** For installations, which have to comply with FCC RF exposure requirements, the antenna selection and installation must be completed in a way to ensure compliance with those FCC requirements. Depending on the RF frequency, rated output power, antenna gain, and the loss between the repeater and antenna, the minimum distance D to be maintained between the antenna location and human beings is calculated according to this formula:

$$D_{[cm]} = \sqrt{\frac{P_{[mW]}}{4 * \pi * PD_{[mW/cm^2]}}}$$

where

- P (mW) is the radiated power at the antenna, i.e. the max. rated repeater output power in addition to the antenna gain minus the loss between the repeater and the antenna.
- PD (mW/cm²) is the allowed Power Density limit acc. to 47 CFR 1.1310 (B) for general population / uncontrolled exposures which is
 - F (MHz) / 1500 for frequencies from 300MHz to 1500MHz
 - 1 for frequencies from 1500MHz to 100.000MHz

RF exposure compliance may need to be addressed at the time of licensing, as required by the responsible FCC Bureau(s), including antenna co-location requirements of 1.1307(b)(3).

13. **Caution:** Installation of this equipment is in full responsibility of the installer, who has also the responsibility, that cables and couplers are calculated into the maximum gain of the antennas, so that this value, which is filed in the FCC Grant and can be requested from the FCC data base, is not exceeded. The industrial boosters are shipped only as a naked booster without any installation devices or antennas as it needs for professional installation.
14. **Caution:** Only suitably qualified personnel are allowed to work on this unit and only after becoming familiar with all safety notices, installation, operation and maintenance procedures contained in this manual.
15. **Caution:** Keep operating instructions within easy reach and make them available to all users.
16. **Caution:** Corresponding local particularities and regulations must be observed. For national deviations, please refer to the respective documents included in the manual CD that is delivered with the unit.
17. **Caution:** Although the remote unit is internally protected against overvoltage, it is strongly recommended to ground (earth) the antenna cables close to the repeater's antenna connectors for protection against atmospheric discharge.
18. **Caution:** ESD precautions must be observed! Before commencing maintenance work, use the available grounding (earthing) system to connect ESD protection measures.



19. **Note:** For a Class A digital device or peripheral:

This equipment has been tested and found to comply with the limits for a Class A digital device, pursuant to part 15 of the FCC Rules. These limits are designed to provide reasonable protection against harmful interference when the equipment is operated in a commercial environment. This equipment generates, uses, and can radiate radio frequency energy and, if not installed and used in accordance with the instruction manual, may cause harmful interference to radio communications. Operation of this equipment in a residential area is likely to cause harmful interference in which case the user will be required to correct the interference at his own expense.

20. **Note:** This unit complies with European standard EN60950.

Equipment Symbols Used / Compliance

Please observe the meanings of the following symbols used in our equipment and the compliance warnings:

Symbol	Compliance	Meaning / Warning
---	FCC	WARNING. This is NOT a CONSUMER device. It is designed for installation by FCC LICENSEES and QUALIFIED INSTALLERS. You MUST have an FCC LICENSE or express consent of an FCC Licensee to operate this device. Unauthorized use may result in significant forfeiture penalties, including penalties in excess of \$100,000 for each continuing violation.
	CE	Alert sign to R&TTE To be sold exclusively to mobile operators or authorized installers – no harmonized frequency bands, operation requires license. Intended use: EU and EFTA countries
CE 0700		Indicates conformity with the R&TTE directive 1999/5/EC certified by the notified body no. 0700.

1.3. ABOUT COMMSCOPE

CommScope is the foremost supplier of one-stop, end-to-end radio frequency (RF) solutions. Part of the *CommScope* portfolio are complete solutions for wireless infrastructure from top-of-the-tower base station antennas to cable systems and cabinets, RF site solutions, signal distribution, and network optimization.

CommScope has global engineering and manufacturing facilities. In addition, it maintains field engineering offices throughout the world.

Andrew Wireless Systems GmbH based in Buchdorf/ Germany, which is part of *CommScope*, is a leading manufacturer of coverage equipment for mobile radio networks, specializing in high performance, RF and optical repeaters. Our optical distributed networks and RF repeater systems provide coverage and capacity solution for wireless networks in both indoor installations and outdoor environments, e.g. tunnels, subways, in-trains, airport buildings, stadiums, skyscrapers, shopping malls, hotels and conference rooms.

Andrew Wireless Systems GmbH operates a quality management system in compliance with the requirements of ISO 9001 and TL 9000. All equipment is manufactured using highly reliable material. To maintain highest quality of the products, comprehensive quality monitoring is conducted at all fabrication stages. Finished products leave the factory only after a thorough final acceptance test, accompanied by a test certificate guaranteeing optimal operation.

This product meets the requirements of the R&TTE directive and the Declaration of Conformity (DoC) itself. A current version of the CE DoC is included in this manual CD delivered *. Any updated version of the DoC is available upon request from the local sales offices or directly from *CommScope* via the local Customer Support at one of the addresses listed in the following chapter.

According to the DoC, our "CE"-marked equipment can be used in all member states of the European Union.

☞ **Note:** **Exceptions of and national deviations from this intended use may be possible. To observe corresponding local particularities and regulations, please refer to the respective documents (also in national language) which are included in the manual CD delivered.**

* In case the Declaration of Conformity (DoC) for the product was not included in the manual CD delivered, it is available upon request from the local sales offices or directly from *CommScope* at one of the addresses listed in the following chapter.

To make the most of this product, we recommend you carefully read the instructions in this manual and commission the system only according to these instructions.

For technical assistance and support, please also contact the local office or *CommScope* directly at one of the addresses listed in the following chapter.

1.4. INTERNATIONAL CONTACT ADDRESSES FOR CUSTOMER SUPPORT

Americas:

Canada	
CommScope Canada	
Mail	505 Consumers Road, Suite 803 Toronto M2J 4V8 Canada
Phone	+1-905-878-3457 (Office) +1-416-721-5058 (Cell)
Fax	+1-905-878-3297
E-mail	Peter.Masih@commscope.com, wisupport@commscope.com

United States	
Andrew LLC, A CommScope Company	
Mail	620 North Greenfield Parkway Garner, NC 27529 U.S.A.
Phone	+1-888-297-6433
Fax	+1-919-329-8950
E-mail	wisupport@commscope.com

Caribbean & South American Region (CALA)	
CommScope Cabos do Brasil Ltda.	
<i>CALA Tech Support for Distributed Coverage & Capacity Solutions (DCCS) products:</i>	
Mail	Rua Guaporanga, 49 Praça Seca – Rio de Janeiro – RJ ZIP: 21320-180 Brazil
Phone	+1-815-546-7154 (Cell) +55-15-9104-7722 (Office)
Fax	+ 55-15-2102-4001
E-mail	wisupport@commscope.com

Caribbean (CALA) & Central American Region	
CommScope Mexico S.A. de C.V.	
<i>CALA Tech Support for Distributed Coverage & Capacity Solutions (DCCS) products:</i>	
Mail	Av. Insurgentes Sur 688, Piso 6 Col. Del Valle, CP: 03100 Mexico City Mexico
Phone	+52-1-55-5419-5260 (Cell) +52-55-1346-1900 (Office)
Fax	+52-55-1346-1901
E-mail	wisupport@commscope.com

APAC Countries:

China, India and Rest of Asia	
Andrew International Corporation	
Mail	Room 915, 9/F Chevalier Commercial Centre 8 Wang Hoi Rd Kowloon Bay Hong Kong
Phone	+852-3106-6100
Fax	+852-2751-7800
E-mail	wisupport.China@commscope.com

Australia & New Zealand	
Andrew Corporation (Australia) Pty Ltd.	
Mail	Unit 1 153 Barry Road Campbellfield VIC 3061 Australia
Phone	+613-9300-7969
Fax	+613-9357-9110
E-mail	wisupport.Australia@commscope.com

Europe:

United Kingdom		Scandinavia	
Andrew Wireless Systems UK Ltd		Andrew Norway (AMNW)	
Mail	Unit 15, Ilex Building Mulberry Business Park Fishponds Road Wokingham Berkshire RG41 2GY England	Mail	P.O. Box 3066 Osloveien 10 Hoenefoss 3501 Norway
Phone	+44-1189-366-792	Phone	+ 47 32-12-3530
Fax	+44-1189-366-773	Fax	+ 47 32-12-3531
E-mail	wisupport.uk@commscope.com	E-mail	wisupport@commscope.com
Germany		France	
Andrew Wireless Systems GmbH		CommScope France	
Mail	Industriering 10 86675 Buchdorf Germany	Mail	Immeuble Le Lavoisier 4, Place des Vosges 92052 Courbevoie France
Phone	+49-9099-69-0	Phone	+33-1 82 97 04 00
Fax	+49-9099-69-930	Fax	+33-1 47 89 45 25
E-mail	wisupport@commscope.com	E-mail	wisupport@commscope.com
Austria		Switzerland	
Andrew Wireless Systems (Austria) GmbH		CommScope Wireless Systems AG	
Mail	Weglgasse 10 2320 Wien-Schwechat Austria	Mail	Tiergartenweg 1 CH-4710 Balsthal Switzerland
Phone	+43-1706-39-99-10	Phone	+41-62-386-1260
Fax	+43-1706-39-99-9	Fax	+41-62-386-1261
E-mail	wisupport.austria@commscope.com	E-mail	wisupport.ch@commscope.com
Italy		Iberia Region - Spain & Portugal	
CommScope Italy S.r.l., Faenza, Italy		Andrew España S.A. A CommScope Company	
Mail	Via Mengolina, 20 48018 Faenza (RA) Italy	Mail	Avda. de Europa, 4 - 2ª pta. Parque Empresarial de la Moraleja Alcobendas, Madrid 28108 Spain
Phone	+39-0546-697111	Phone	+34-91-745-20 40
Fax	+39-0546-682768	Fax	+34-91-661-87 02
E-mail	wisupport.italia@commscope.com	E-mail	wisupport.iberia@commscope.com

Czech Republic	
CommScope Solutions Czech Republic C-Com, spol. s r.o	
Mail	U Moruší 888 53006 Pardubice Czech Republic
Phone	+49 871 9659171 (Office) +49 171 4001166 (Mobile)
Fax	+49 871 9659172
E-mail	wisupport@commscope.com

Africa & Middle East:

Middle East & North Africa	
CommScope Solutions International Inc. (Branch)	
Mail	PO Box 48 78 22 Unit 3206, Floor 32, Jumeirah Business Center 5, Jumeirah Lakes Towers, Dubai United Arab Emirates
Phone	+971 4 390 09 80
Fax	+971 4 390 86 23
E-mail	wisupport@commscope.com

South Africa	
Andrew Wireless Solutions Africa (PTY) LTD	
Mail	11 Commerce Crescent West Eastgate, Sandton PO Box 786117 Sandton 2146 South Africa
Phone	+ 27 11-719-6000
Fax	+ 27 11-444-5393
E-mail	wisupport@commscope.com

table 1-1 List of international contact addresses

2. INTRODUCTION

2.1. PURPOSE

Cellular telephone systems transmit signals in two directions between a base transceiver station (BTS) and mobile stations (MS) within the signal coverage area.

If weak signal transmissions occur within the coverage area because of indoor applications, topological conditions or distance from the transmitter, extension of the transmission range can be achieved by means of an optical distribution system.

Such a system contains an optical Master Unit and several Remote Units. The number of the Remote Units depends on the hardware and software configuration. The Remote Units are connected to the Master Unit with optical links. The optical loss must be less than 10 dB inclusive optical couplers or splitters.

The Master Unit is the connection to the base transceiver stations. The configuration of a Master Unit depends on the number of the Remote Units and the frequency range.

WDM (Wave Division Multiplex) filters are integrated in the optical modules. For the UL, a wavelength within 1540 nm - 1562 nm is used. For the DL, a wavelength of 1310 \pm 20 nm is used. The maximum output power for the UL and DL is 6.7 mW.

2.2. THE ION-M7P/80-85HP/9 (INTELLIGENT OPTICAL NETWORK; MMR)

The ION-M7P/80-85HP/9 is a multi-band, multi-operator Remote Unit. It is used in conjunction with a Master Unit in the ION optical distribution system.

The ION-M7P/80-85HP/9 transports signals on the RF layer in a very inexpensive manner. This means that multiple operators and multiple technologies are moved simultaneously from a cluster of base stations to a remote location over the same fiber.

The ION optical distribution system is a cost-effective coverage solution for dense urban areas, tunnels, subway, airports, convention centers, high-rise buildings and other locations where physical structures increase path loss. It has been specifically designed to reduce zoning problems and to provide homogeneous coverage. The compact, mechanical design is specifically architected to mount along side structures in such a way that it has a minimal visual impact.

The ION-M7P/80-85HP/9 has been specifically tested and optimized for GMSK, EDGE, CDMA, WCDMA, and LTE modulation in the 700 MHz, 800/850 MHz, 900 MHz band as well as AMPS, LMR and analogue modulations.

By means of a coupling port AWS (1700/2100) and PCS (1900) provided by a separate ION-M can be combined with 700 MHz, 800 MHz, 850 MHz, and 900 MHz to one antenna port. The Remote Unit is equipped with an extension port to upgrade the system for supporting AWS/PCS.

The ION is easily set-up and supervised via a graphical user interface (GUI). Remote units can be commissioned through the use of built-in test equipment. An auto-leveling function compensates for the optical link loss making installation easy and quick. The entire system may be monitored remotely via an Andrew OMC. This platform uses SNMP protocol and is compliant to X.733 standard.

Should a sophisticated interface not be required, the master unit can be directly connected to the alarm interface of a base station via its contact relay.

Features:

- Multi-channel, multi-operator support
- Efficient, high power amplifiers
- Single fiber for MIMO and multiple remotes
- Comprehensive operations and management system for configuration and alarming
- OMC with SNMP according to X.733 standard
- 3GPP TS25.143/TS25.106/ TS36.143/TS36.106 and 3GPP2C.S0051-0 compliant
- Single fiber for multiple bands and multiple remotes
- Easy installation and commissioning

3. COMMISSIONING

3.1. MECHANICAL INSTALLATION

3.1.1. General

Read the health and safety warnings in chapter *1.2 Health and Safety Warnings* .

WARNING: IMPROPER INSTALLATION CAN LEAD TO EQUIPMENT FALLING CAUSING SERIOUS PERSONAL INJURY OR DAMAGE TO EQUIPMENT. The installer must verify that the supporting surface will safely support the combined load of the electronic equipment and all attached hardware and components. The screws and dowels (wall anchors) used should also be appropriate for the structure of the supporting wall.

1. Do not install the unit in a way or at a place where the specifications outlined in the Environmental and Safety Specifications leaflet of the supplier are not met.
2. It is recommended only to use the mounting hardware delivered by the supplier. If different mounting hardware is used, the specifications for stationary use of the Remote Unit must not be exceeded.

 **Note:** Exceeding the specified load limits may cause the loss of warranty!

-  3. The unit is considerably heavy. Make sure that a suitable mounting surface is used. Ensure there is adequate manpower to handle the weight of the system.
4. Due to power dissipation, the Remote Unit may reach a very high temperature. Ensure sufficient airflow for ventilation as specified in the individual mounting procedures.
5. When connecting and mounting the cables (RF, optical, mains, ...) ensure no water can penetrate into the unit through these cables.
6. Also observe all additional rules or restrictions regarding mounting that depend on the type of Remote Unit. For details refer to chapter *7.2.2 Mechanical Specification*. Install the unit vertically with the fan unit at the top. A maximum tilt angle of 25° from a vertical position must be kept, as in the following illustrations:

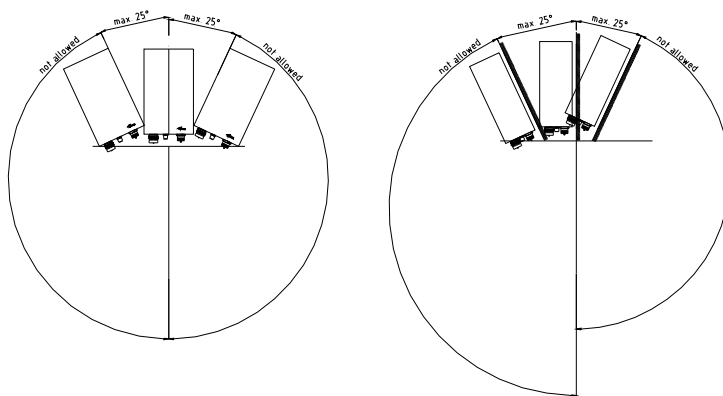

7. A spacing of 40 mm (1.58 inch) around the unit is required.

8. To ensure sufficient airflow when mounting the unit in enclosed spaces, two lid openings (one for the air inlet and the other for the air outlet) have to be provided. Do not block these air inlets and outlets when mounting the Remote Unit. The size of each opening must equal at least 17 x 17 cm (290 cm²). Make sure, too, there is no thermal short circuit between the air inlet and air outlet.

If any different or additional mounting material is used, ensure that the mounting remains as safe as the mounting designed by the manufacturer. Ensure that the static and dynamic strengths are adequate for the environmental conditions of the site. The mounting itself must not vibrate, swing or move in any way that might cause damage to the Remote Unit.

Specified torques have to be observed for certain mounting procedures according to the following table:

Type	Tallow-drop screws	Hex nuts	Spacing bolts		PG (plastic)	PG (aluminium)
Thread	M 4	M 8	M 4	M 8	PG 13.5	PG 29
Specified torques	3.3 Nm	27 Nm	2.3 Nm	27 Nm	3.75 Nm	10 Nm

table 3-1 Specified torques

Note: To avoid damage when mounting the unit, always make sure that the M8 washers (DIN9021 or DIN125 depending on the mounting kit) are placed behind and in front of the mounting drillings of the unit.

The mounting procedures for a stand-alone Remote Unit without optional accessories are described and illustrated in the following sections. For further information regarding special mounting procedures including mounting of accessory equipment, please see separate manual.

3.1.2. Wall-Mounting Procedure

- Check the suitability of the wall-mounting kit and the wall.
- Remove the protective cover from the top of the Remote Unit by pulling it strongly to the front.

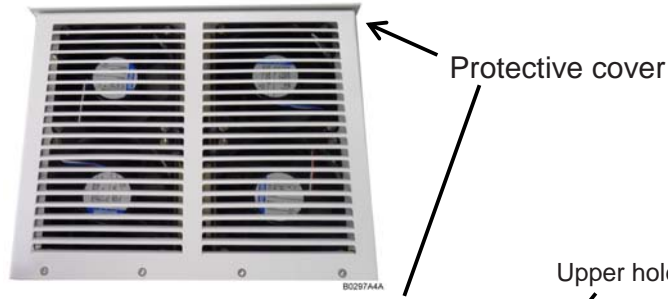

- Mark the position of the drilling holes (for exact measurements refer to the wall mounting plan that is part of the delivery). Drill three holes at the marked positions and insert dowels*.
- Choose the screw type you want to use: two possible sets are provided in the kit; for details see mounting plan.
- Screw two screws with the according washers / nuts into the two upper dowels but do not fasten them.
- Hang the Remote Unit with the two upper holes into the upper screws and, then, fasten them tight using an appropriate tool.

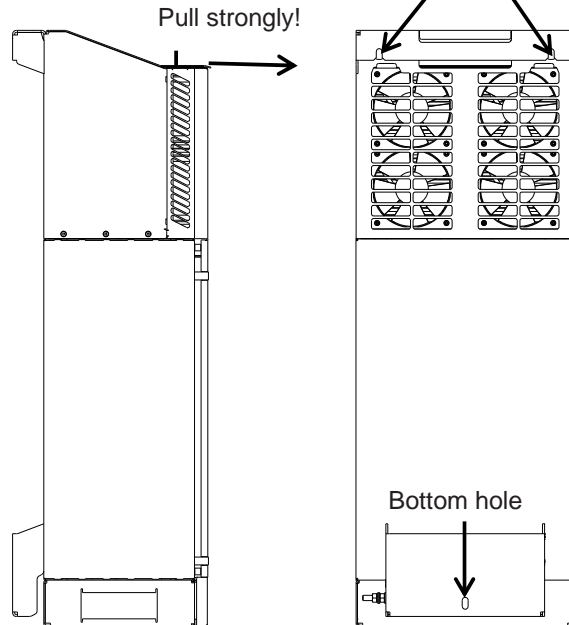

figure 3-1 Wall mounting

* The dowels are not part of the delivery since the suitable type depends on the on-site conditions (material of wall). Therefore, use dowels that are appropriate for the mounting surface.

- Then, put the third screw with the according washers / nuts through the bottom hole of the Remote Unit and screw it into the third dowel using an appropriate tool.
- Put the protective cover back on top of the Remote Unit.
- Ensure that there is free access to the electrical connections as well as to the cabinet. The approved bending radius of the connected cables must not be exceeded.

3.2. ELECTRICAL INSTALLATION

3.2.1. General

Read the health and safety warnings in chapter 1.2.



1. This unit contains dangerous voltages. Loss of life, severe personal injury or property damage can be the result if the instructions contained in this manual are not followed.
2. It is compulsory to ground the unit before connecting power supply. A grounding bolt is provided on the cabinet to connect the ground-bonding cable.
3. Although the Remote Unit is internally protected against overvoltage, it is strongly recommended to earth the antenna cables close to the antenna connectors of the Remote Unit for protection against atmospheric discharge. In areas with strong lightning it is strongly recommended to insert additional lightning protection.
4. If the mains connector of the Remote Unit is not easily accessible, a disconnect device in the mains circuit must be provided within easy reach.
5. Before connecting or disconnecting the mains connector at the Remote Unit, ensure that mains supply is disconnected.
6. Make sure that an appropriate branch circuit breaker and an overcurrent limiting device are connected between mains and Remote Unit.
7. An external circuit breaker is mandatory as disconnect device. This circuit breaker should be readily available for the operator.

For the U.S. and Canada, installation has to be done in accordance with the NEC (National Electronic Code). The external circuit breaker has to be a branch circuit breaker rated 20 A for 110 Vac mains.

8. A field wiring box with conduit must be used for the installation. Use a wire harness rated for AC mains with at least AWG14 size.
9. A connection of mains supply to a power socket requires the power socket to be nearby the Remote Unit.
10. Incorrectly wired connections can destroy electrical and electronic components.
11. To avoid corrosion at the connectors caused by electrochemical processes, the material of the cable connectors must not cause a higher potential difference than 0.6 V (see electrochemical contact series).
12. Use an appropriate torque wrench for the coupling torque (25 N-m / 19 ft lb) of 7/16-DIN connectors with 1 ¼-inch opening to tighten the 7/16-type antenna connectors. For example, use torque wrench of item no. 244377 available from the *Andrew e-catalog*. Do NOT use your hands or any other tool (e.g. a pair of pliers)! This might cause damage to the connector and lead to a malfunction of the Remote Unit.

13. For unstabilized electric networks which frequently generate spikes, it is advised to use a voltage limiting device.
14. The unit complies with the surge requirement according to EN 61000-4-5 (fine protection); however, it is recommended to install an additional medium (via local supply connection) and/or coarse protection (external surge protection) depending on the individual application in order to avoid damage caused by overcurrent.
15. Observe the labels on the front panels before connecting or disconnecting any cables!

3.2.2. Connections

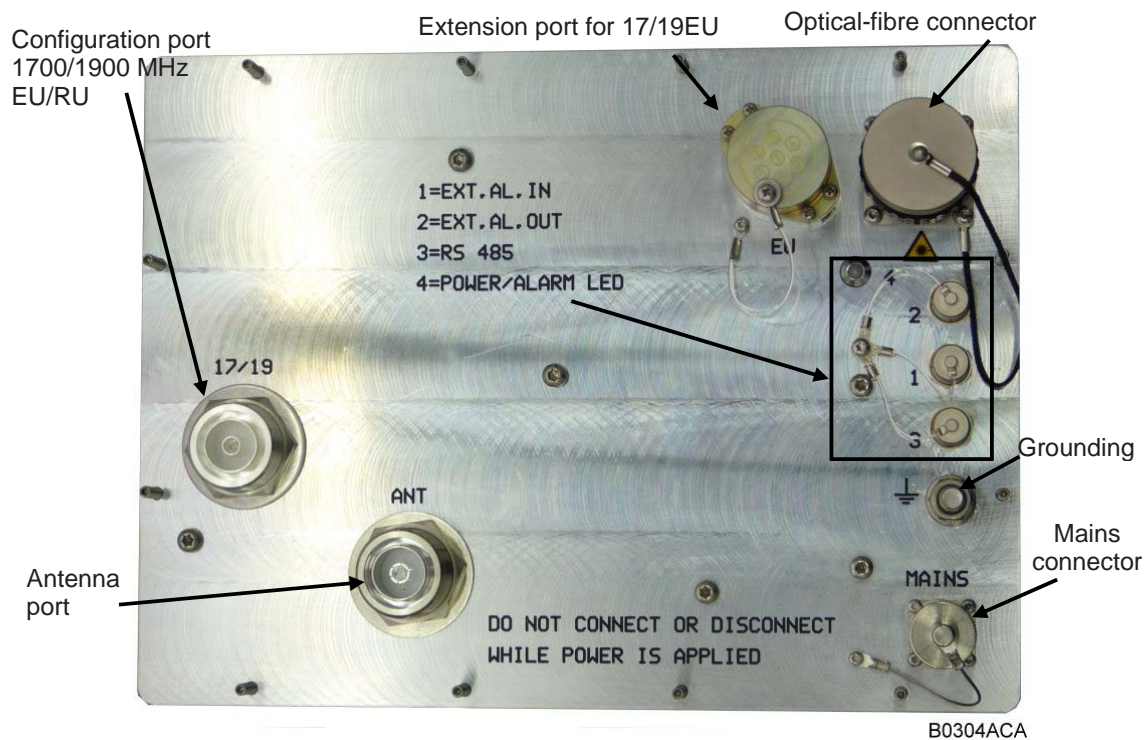

figure 3-2 Connector flange of ION-M7P/80-85HP/9

Control Connector (RS485 / RS232)

This 8-pin male connector (type: Binder Series 712) primarily supports control of the Extension Unit via RS485 bus.

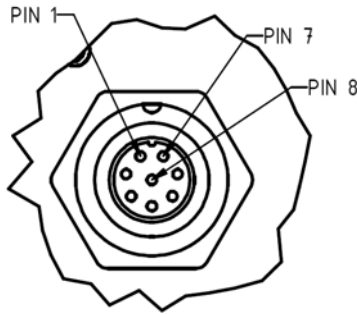

figure 3-3 RS485 connector

PIN	Assignment
1	RS232 Rx CM2
2	RS232 Rx CM1
3	RS232 Tx CM1
4	RS232 Tx CM2
5	GND (RS232)
6	RS485 RD+
7	RS485 GND
8	RS485 RD

table 3-2 RS485 connector, pin assignment

Please observe the caution labels attached to the unit cabinet.

3.2.3. Grounding

Grounding must be carried out. Connect an earth-bonding cable to the grounding connection provided at the connector flange of the Remote Unit (see chapter 3.2.2 *Connections*). Do not use the grounding connection to connect external devices.

After loosening the hex nut, connect the earth-bonding cable between the two washers as illustrated in the figures above. Then, fasten all parts again with the hex nut.

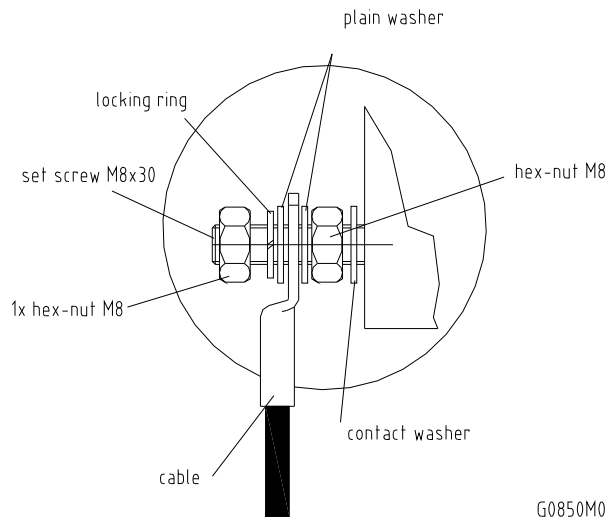
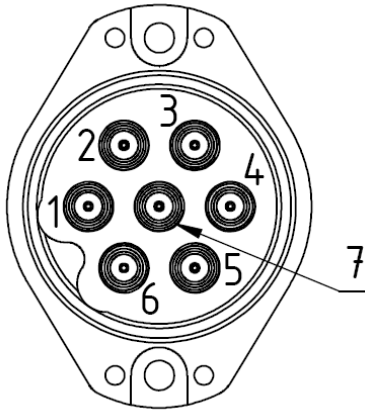

figure 3-4 Grounding bolt, schematic view

3.2.4. Connection of the Extension Unit

This 7-pin extension-port connector (type: Andrew standard) is equipped with one cable bridge with four RF cables. Connect this cable bridge at the “Extension port connector” of the RU (see *figure 3-2*) with the corresponding connector at the EU.



PIN	Assignment
1	Not used
2	Not used
3	OTRx 17-21 UL
4	OTRx 17-21 DL
5	Not used
6	RS485 D+/R+
7	RS485 D-/R-

figure 3-5 Extension-port connector

table 3-3 Extension-port connector, pin assignment



To prevent damaging the connectors of the extension port, align the plug end of the connector properly before inserting. Do not twist the connector. When the connector is in place, tighten the screws in a clockwise direction. Particular attention must be paid plugging this connector to maintain the ingress protection class of the Remote Unit.

3.2.5. Connection of the Antenna Cables

The Remote Unit has 7/16-type antenna connectors. For its location please refer to chapter 3.2.2 *Connections*. For mounting the cable connectors, it is recommended to refer to the corresponding documentation of the connector manufacturer. The bending radius of the antenna cables must remain within the given specifications.

For the selection of cable and antenna it should be considered that, on the one hand, a cable with higher loss is less expensive but, on the other hand, it impairs performance.



Use an appropriate torque wrench to tighten the 7/16 DIN-type (1 ¼ -inch opening) antenna connectors to a coupling torque of 25 N-m / 19 ft lb. Torque wrench item no. 244377, available from the CommScope e-catalog, is recommended. Do NOT use your hands or any other tool (e. g. a pair of pliers)! This might cause damage to the connector and lead to a malfunction of the Remote Unit or increased PIM.

3.2.6. Power Connection

Before connecting electrical power to the units, the system must be grounded as described in the previous chapter.

Mains power must be connected at the mains connectors of the unit (see chapter 3.2.2 *Connections*).

The power supply plug is part of the delivery. The correct wiring of the 4-pin AC mains connector is as follows:

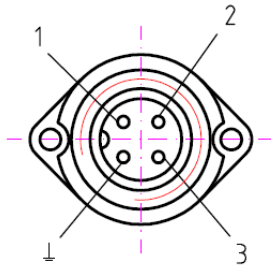

Pin	Description
1	Phase (brown)
2	Neutral (blue)
3	n.c.
4	PE (green/yellow)



For the AC power supply connection, a minimum cross section of 1.5 mm² is required. Each wire must observe the applicable national regulations regarding loop impedance, voltage drop, and methods of installation. Make sure to connect the correct voltage to the unit.

Note: Do not connect or disconnect the power cord at the mains connector while power is on. Turn off mains power* before connecting the power cord at the remote unit, then, engage mains again.

* Mains power must be interruptible with an external mains breaker. For the mains breaker, observe the following recommendation:

120 Volt / 20 Amp max. or 240 Volt / 16 Amp, single-phase, 50 / 60 Hz AC service is needed, i.e. the external AC breaker should be 20 Amps max. for 120-Volt service or 16 Amps for 240-Volt service.

With the mains power turned off, the power supply plug must be connected to the remote unit's Mains connector. The Mains connector's arrow tip and the power supply plug's arrow tip must point to each other as shown in the figure unterhalb.

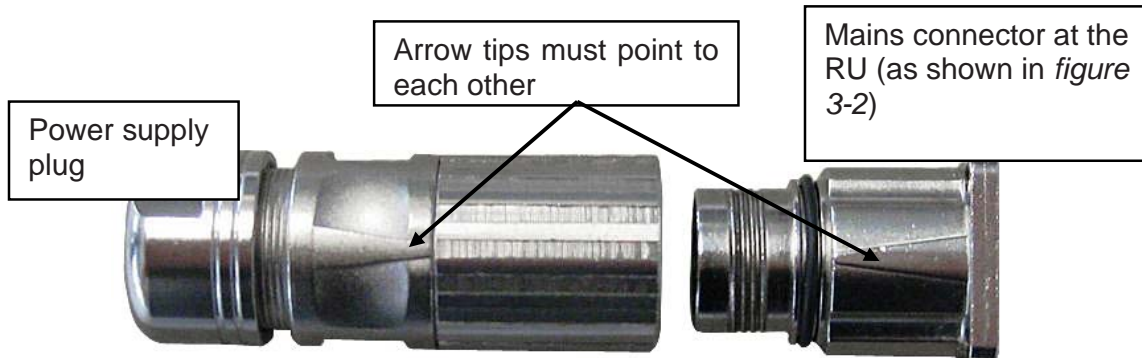

figure 3-6 Power supply plug to RU Mains connector

3.3. OPTICAL-FIBRE-CABLE CONNECTION - RULES

Main optical system parameters:

Fiber:

- Single mode fiber, type is E9/125 μm
- Attenuation: $<0.36 \text{ dB / km @ } 1310 \text{ nm}$ / $<0.26 \text{ dB / km @ } 1550 \text{ nm}$
- Dispersion: $<3.5 \text{ ps / nm km @ } 1310 \text{ nm}$ / $<18.0 \text{ ps / nm km @ } 1550 \text{ nm}$
- Fibre-cable connectors E2000APC8°

ION-M system:

- The pigtails for the connection between Master Unit and Remote Unit must have a sufficient length. A protection for the feeding into units must be given.
- The system attenuation of the optical fibers, including the connectors, must not exceed 10 dB.

System attenuation and attenuation of optical components must be determined. This can be achieved by measuring attenuation and reflection with an appropriate measuring instrument. For pigtails, a total value of $<0.4 \text{ dB}$ (measured to a reference plug) can be assumed due to the dead zone of the reflectometer. These measurements must be made with a sufficient length of optical fiber, at the input and output of the device which has to be measured.

Fiber-System Installation:

Fiber-cable connectors have to be of the same type (E2000APC8°) as the connectors used for the unit. The fiber-optic cables are connected to the optical transceiver.



Angled connectors are not compatible with straight optical connectors; non-compatibility of connectors will result in permanent damage to both connectors.

Before connecting the fiber cables, follow the procedure below to ensure optimized performance. It is important for these procedures to be carried out with care:

- Remove fiber-optic protective caps.
- Do not bend the fiber-optic cable in a tight radius ($< 4 \text{ cm}$) as this may cause cable damage and interrupt transmission.
- Using high-grade alcohol and lint-free cotton cleaning swabs, clean the end of the fiber-optic cable that will be inserted in the optical connectors on the donor interface box. Use a fiber end-face inspection tool to scan both, the class fiber and its surrounding area.
- Check for dirt on the cladding, chips/pits, dirt on the ferrule, and scratches.

- Connect the fiber-optic cables by inserting the cable end into the laser receptacle and aligning the key (on the cable end) with the keyed slot.
- Do not use any index-matching gels or fluids of any kind in these connectors. Gels are intended for laboratory use and attract dirt in the field.

 **Note:** Care should be taken when connecting and disconnecting fiber-optic cables - use the connector housing to plug or unplug a fiber. Scratches and dust significantly affect system performance and may permanently damage the connector. Always use protective caps on fiber-optic connectors not in use.

Cleaning Procedure for Fiber-Optical Components:

Any contamination in the fiber connection results in additional optical transmission loss which could cause whole system failure. It is thus recommended that every fiber connector be inspected and cleaned prior to mating.

The goal is to eliminate any dust or contamination and to provide a clean environment for the fiber-optic connection.

When you clean fiber components, always complete the following steps carefully:

1. Turn off the ION system (laser sources) before you inspect fiber connectors.



Never look into a fiber while the system lasers are on!

2. Check the connectors or adapters with a fiberscope before cleaning.
3. If the connector is dirty, clean it with a lint-free wipe (dry cleaning).
4. Inspect the connector.
5. If the connector is still dirty, repeat the dry cleaning technique.
6. Inspect the connector.
7. If the connector is still dirty, clean it with 99% isopropyl alcohol (wet cleaning) followed immediately with a dry clean in order to ensure no residue is left on the endface.
8. Repeat steps 5 through 7 until endface is clean.

Note: For a more detailed description please refer to:

http://www.cisco.com/en/US/tech/tk482/tk876/technologies_white_paper09186a0080254eba.shtml

3.3.1. Protective Plug

Connection:

A protective plug is provided for the connection of the fibre-optic cables.

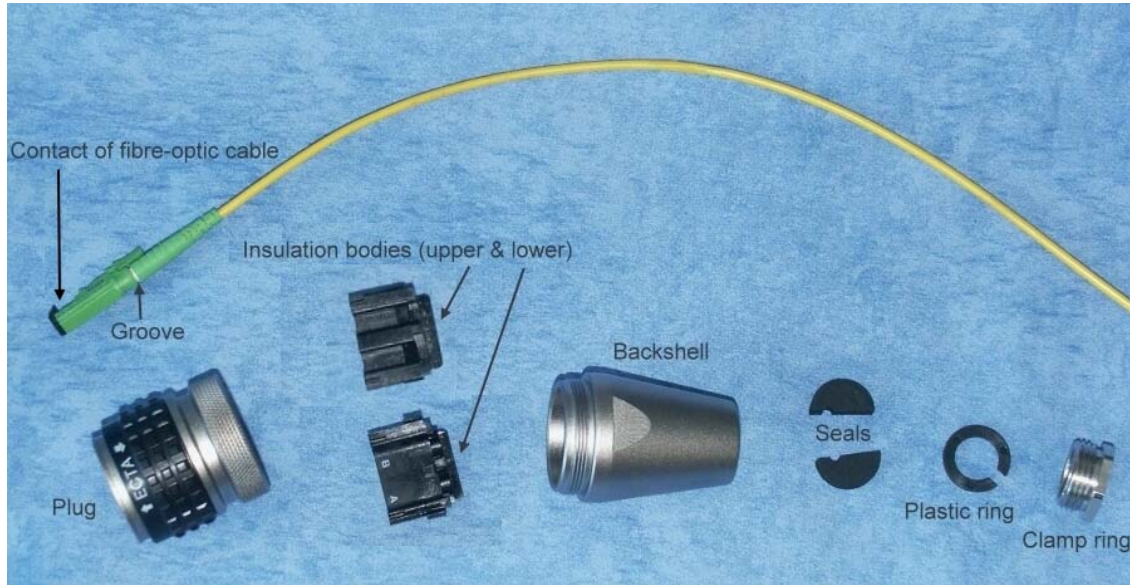

B0122AMA

figure 3-7 Protective-plug assembly

Note: Only high-quality connectors must be used for this type of plug. Qualified brands are Diamond or Huber & Suhner.

For plug assembly, observe the following instruction:

1. Pass one or two contacts through the backshell and the clamp ring.



B0122A1A

2. Place the contact(s) on the lower insulation body by pushing the groove of the contact into the cavity. If there is only one contact, cavity A **must** be used. *
3. Then, mount the upper insulation body on the lower insulation body. **

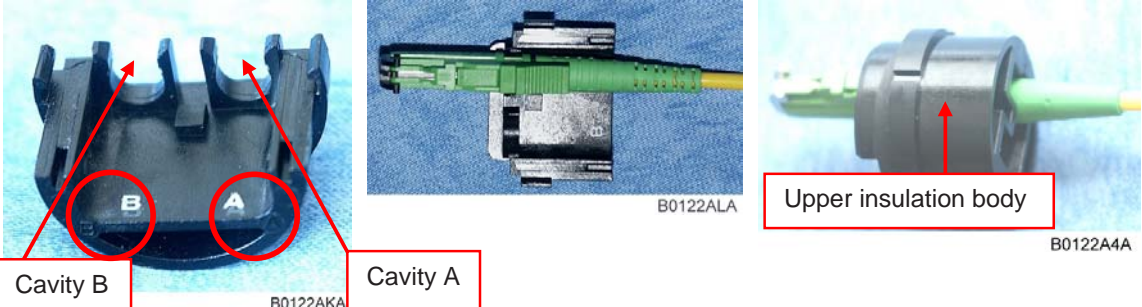

Upper insulation body

B0122A4A

4. Bring the insulator into the plug. The narrow groove of the insulator must be fitted into the stamp of the plug.

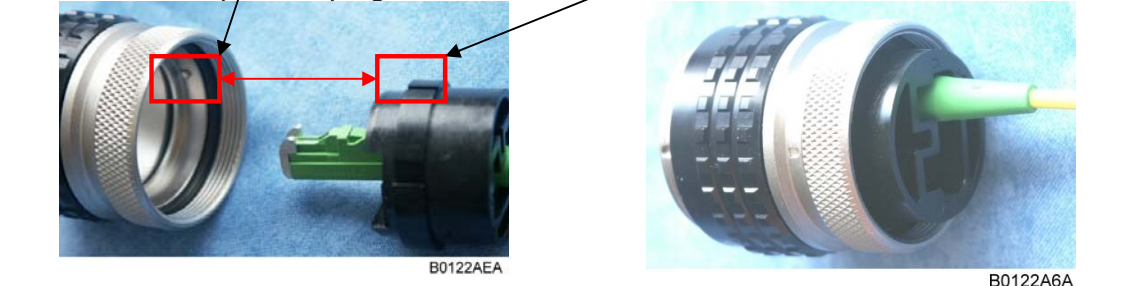

B0122A6A

- * To release the contact for disassembling, push the inner snap to the side and pull the contact out.
- ** To release upper and lower insulation bodies for disassembling, use a small screwdriver and carefully open the snap-connections at the left and the right side of the insulator without damaging them.

5. Fasten the insulator by screwing the backshell tight onto it. Use a spanner with opening 32 to screw the backshell tight (no gap).
6. Place the appropriate seal parts (with one groove for one contact or two grooves for two contacts) over the cable(s) and push them into the backshell.

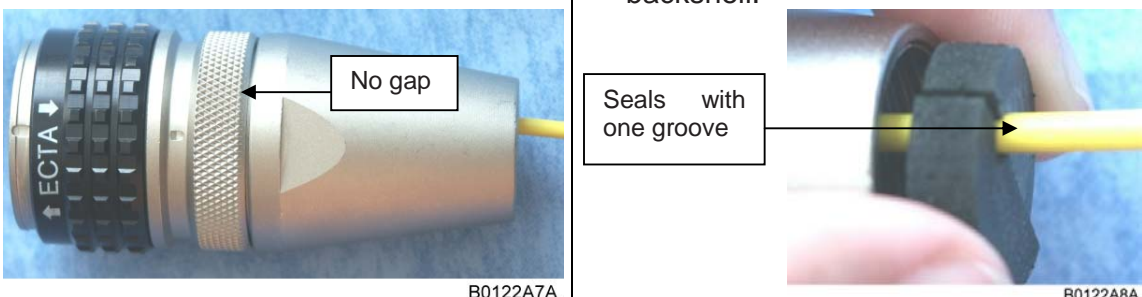

No gap

Seals with one groove

B0122A7A

B0122A8A

7. Bring the plastic ring over the cable(s), push it into the backshell and compress the seals and plastic ring by screwing the clamp ring tight (no gap) using a spanner with opening 20. ***

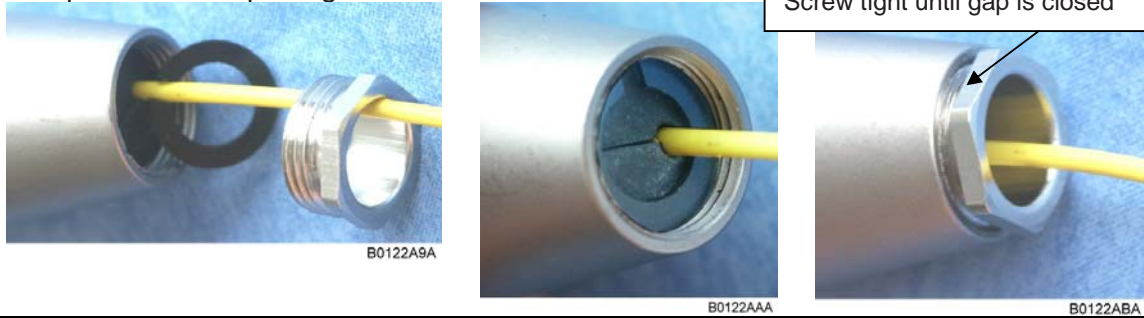

8. Connect the plug to the optical-fibre connector of the remote unit, again by fitting a stamp on the plug into the groove of the connector.

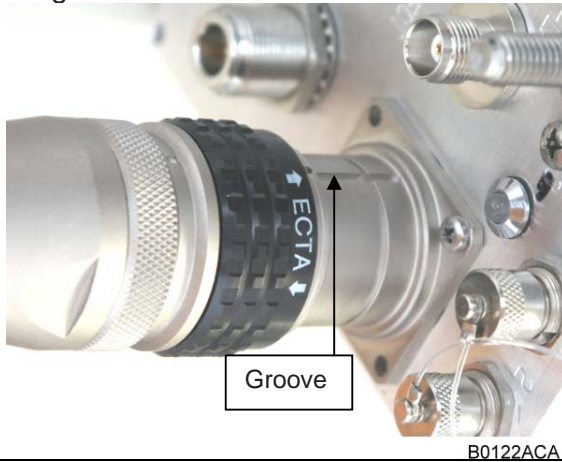

9. To lock the connector, push the black locking ring forward.****

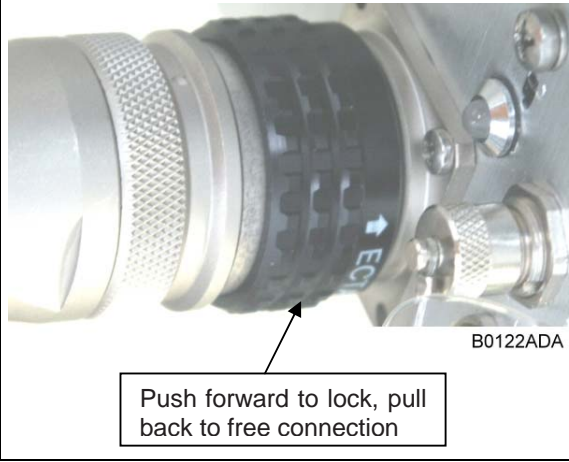

*** For disassembling, release the clamping ring and remove the seals and the plastic ring first.

**** Locking mechanism: The system of locking the plug is based on a "push-pull" mechanism. The locking ring has to be pushed forward to lock the connector and pulled back to free the connection.

3.3.2. Protective-Tube Kit

As additional protection for the optical fibers, this connector type can be supplemented by a special tube kit. To fasten the tube correctly, first unscrew the clamp ring (if already installed) of the original plug kit.

Then, proceed according to the following instruction:

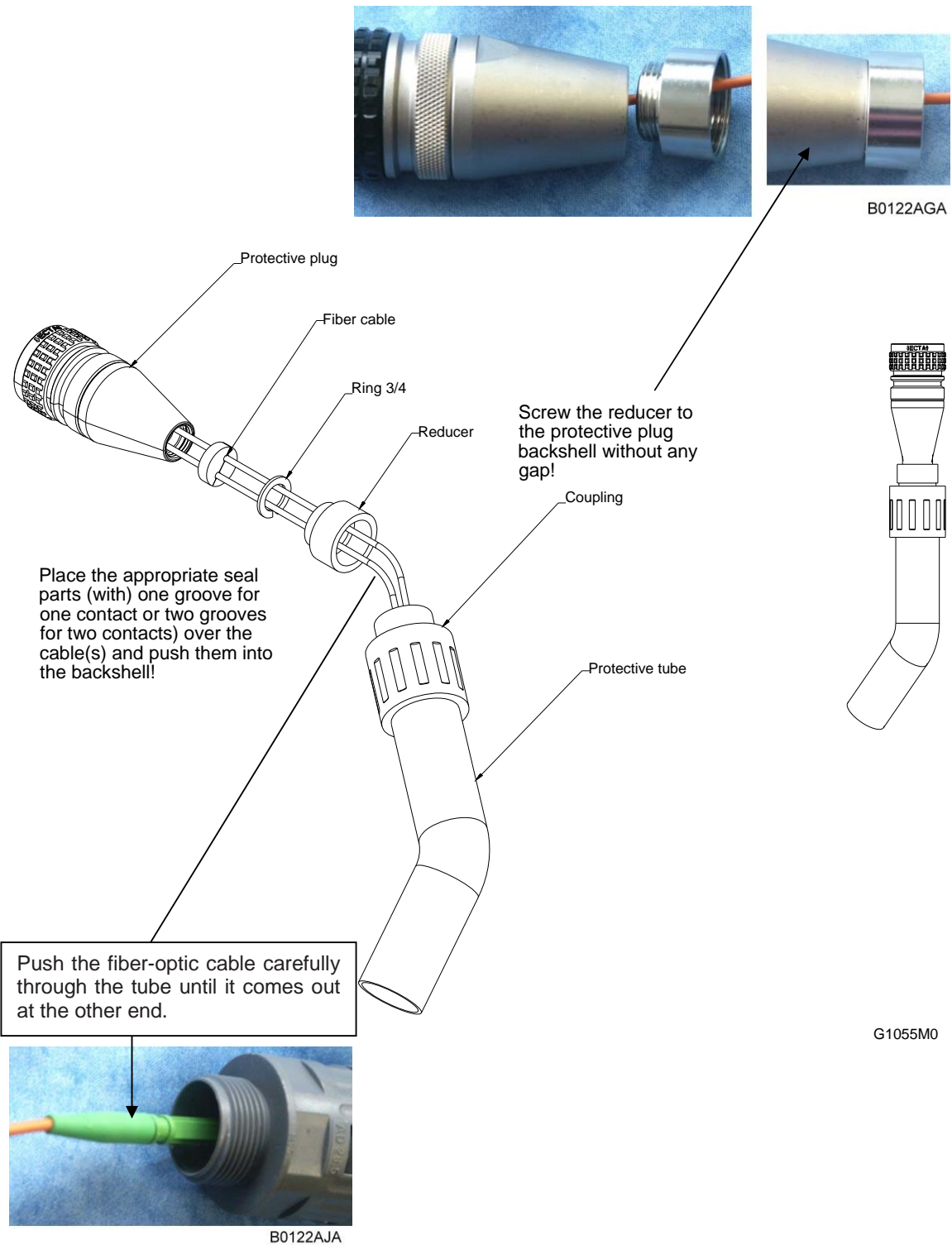

figure 3-8 Tube-kit installation

3.4. COMMISSIONING

Read the health and safety warnings in chapter 1.2 as well as the description carefully to avoid mistakes and proceed step by step as described!

- Do not operate the Remote Unit without terminating the antenna connectors. The antenna connectors may be terminated by connecting them to their respective antennas or to a dummy load.
- Only qualified personnel should carry out the electrical, mechanical, commissioning and maintenance activities that require the unit to be powered on when open.
- When opening the Remote Unit do not damage the warranty labels on the internal devices. The warranty is void if the seals are broken.
- Ensure that all connections have been performed according to chapter 3.2.2 *Connections*.

Commissioning an ION-M Remote Unit

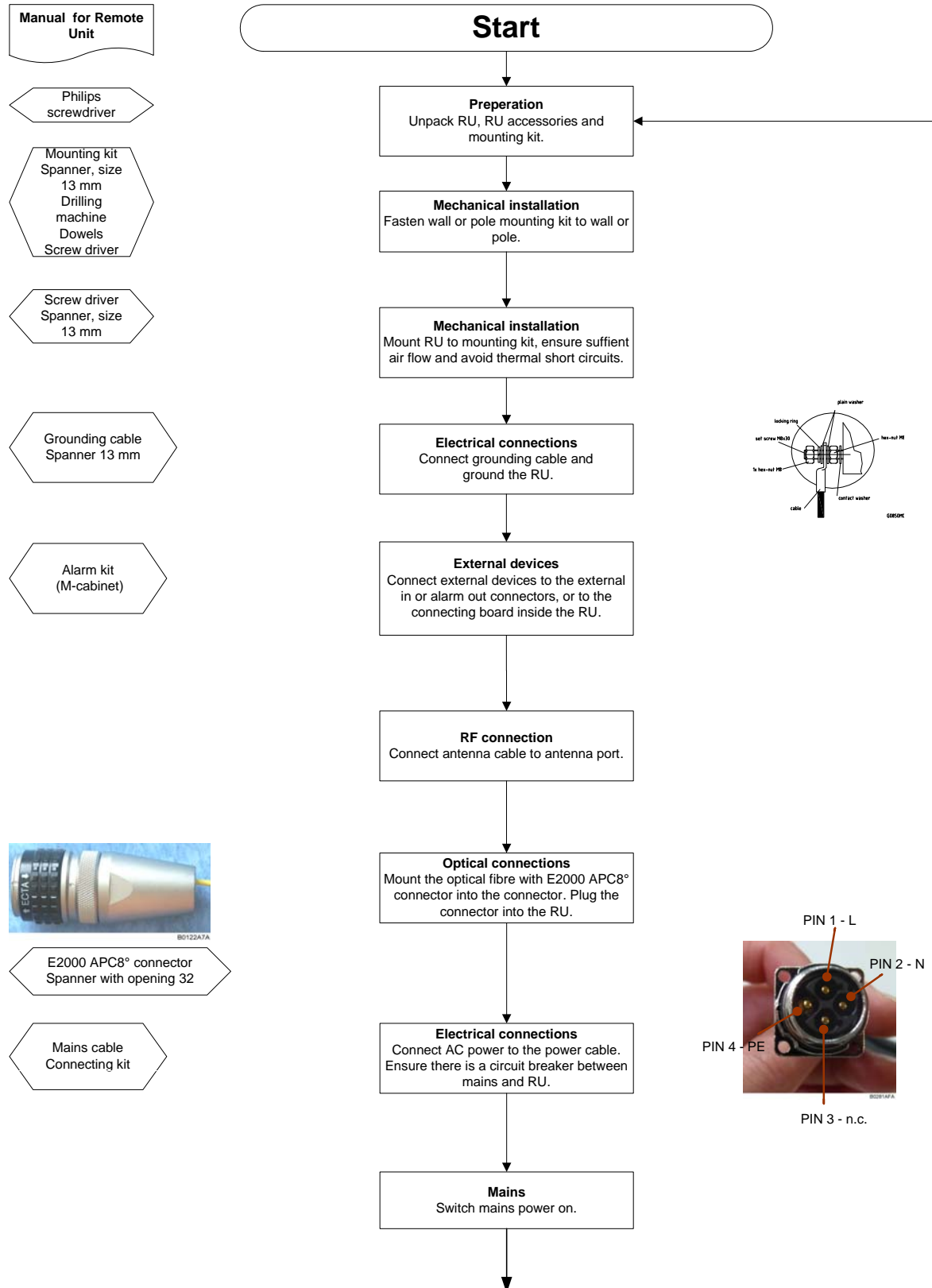

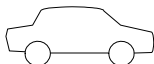
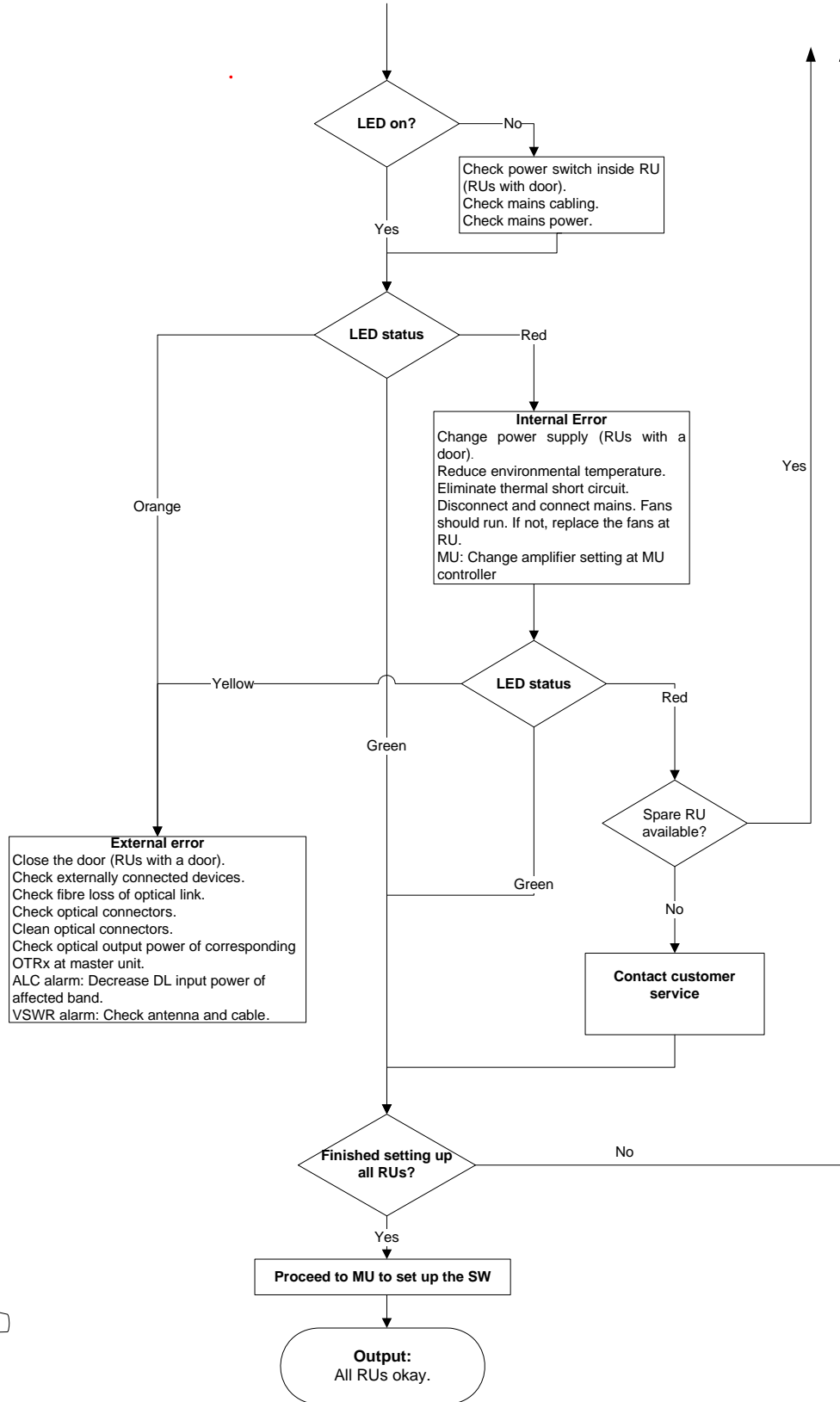

Go to MU

4. ALARMS

4.1. BITE AND ALARMS

The Built-In Test concept comprises the monitoring of the power supplies, the power amplifiers and the optical interface.

All occurring alarms can be checked via software at the Master Unit.

4.2. HANDLING OF ALARMS

As soon as the software acknowledges a valid alarm, a message is transmitted to the Master Unit.

If the reason for the alarm has been cleared or if the alarm should continue, a new alarm message will not be repeated. If there was an interruption of at least five seconds after acknowledgement, a new alarm message will be generated.

4.3. ALARM STATUS

For details refer to the corresponding software documentation of the Master Unit.

4.4. STATUS LED ALARMS

For local supervision, a status LED on the connector flange of the remote unit gives an indication of possible reasons for alarms. This table shows possible on-site measures that could be checked before referring to the master unit alarm list.

Status LED Indication	Alarms	Possible on-site measures
Green	No alarm → Status ok	
Orange	Door alarm	Close the door (RUs with door).
	<i>Alarms not directly related to RU:</i>	
	External alarms	Check externally connected devices.
	Optical alarm Rx	Check fibre loss of optical link. Check optical connectors. Clean optical connectors. <i>(MU: Check optical output power of corresponding OTRx at master unit).</i>
	ALC alarm	<i>(MU: Decrease DL input power of affected band).</i>

Status LED Indication	Alarms	Possible on-site measures
Red	<i>Alarms directly related to RU:</i>	
	Power 28 V	Change power supply (RUs with door). Replace the affected remote unit.
	Temperature	Reduce environmental temperature. Eliminate thermal short circuit.
	Fan	Disconnect and connect mains. Fans should run. If not, replace the fans at RU.
	I ² C	Disconnect and connect mains.
	Optical alarm Tx	Exchange RU.
	Amplifier "Power Down"	<i>(MU: Change amplifier setting at MU controller).</i>
Status LED off	Mains	Check power switch inside of RU (RUs with door). Check mains cabling. Check mains power.

table 4-1 Status LED alarms

For the position of the status LED see chapter 3.2.2 *Connections*.

Explicit troubleshooting is available in the MU software (software manual or WEB Interface).

4.5. EXTERNAL ALARM INPUTS AND OUTPUTS

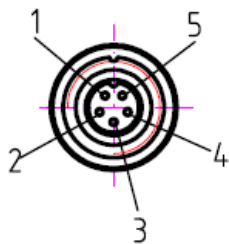

Pin	Description
1	Alarm input 1
2	Alarm input 2
3	Alarm input 3
4	Alarm input 4
5	Alarm GND

figure 4-1 Flange connector, 5 poles

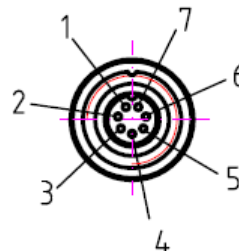

Pin	Description
1	External output 1
2	External output 2
3	External output 3
4	External output 4
5	Alarm GND*
6	GND*
7	+28V

figure 4-2 Flange connector, 7 poles

The alarm outputs (open collector output 5 V / 1 mA) are normally low. In case of an alarm they are high active (5 V). They can be used to monitor alarms with an external alarm indicator.

The +28 V pin (for its location see *figure 4-2 Flange connector, 7 poles*) is specified to 28 VDC/1A and is protected by a thermoswitch. In case of exceeding this current between pin 7 and GND and/or in case of a failure of the VSWR module, the thermoswitch turns into a high-resistive status. In this case no fuse needs to be replaced. Just wait a few minutes until the thermoswitch reaches the normal operating temperature again.

Note: The manufacturer / supplier of this system accepts no liability for damage caused by equipment connected to external outputs or by effects from such equipment.

As accessory equipment, the alarm kit is available to connect external devices to the external alarm inputs and outputs. For the exact designation, please refer to chapter 6.3 *Spare Parts*.

With the external alarm inputs it is possible to monitor the status of connected devices, e.g. a UPS, via software. All alarm inputs are normally high (5 V) without connection. The polarity (high/ low) can be set via the software at the Master Unit (for details please see according software manual).

The device to be monitored must be connected so that the alarm contacts will be closed in case of an alarm (I max = 8 mA). The alarm inputs are potential-free with common ground.

Subminiature circular connectors series 712 with five and seven contacts, which are contained in the alarm kit, can be ordered directly from the Binder Connector Group, the manufacturer, or indirectly from CommScope. For the designation of the alarm kit see chapter 6.3 *Spare Parts*.

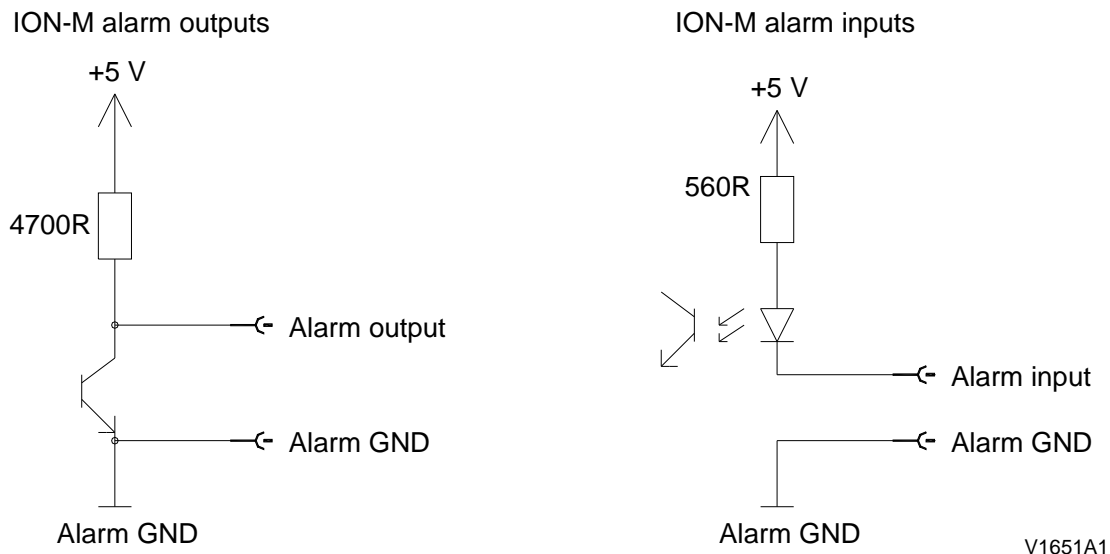

figure 4-3 Alarm inputs and outputs, standard

4.6. TROUBLESHOOTING

The status of the Remote Unit can be checked via the Master Unit (for details please refer to the software manual of the Master Controller). Locally, the status can be checked at the LED, see chapter 4.4 *Status LED Alarms*.

5. MAINTENANCE

5.1. GENERAL

Read the health and safety warnings in chapter 1.2.

Note: The Remote Unit does not require preventative maintenance measures.

Note: To prevent malfunctions of the cooling system due to dirt or pollution, it is recommended to clean the heat sink at regular intervals. These cleaning intervals depend mainly on the location of the Remote Unit and the corresponding degree of pollution.

Maintenance of the ION-M7P/80-85HP/9 should be performed by replacing only components that are contained in this chapter. In order to maintain warranty, take care not to damage unintentionally the seals on the modules.

The spare parts list, consequently, contains only units which can be replaced without tuning or soldering work.

Note: When sending back the unit, use an appropriate packaging, see chapter 6.2.2 *Mechanical Specifications*. We strongly recommend using the original packaging!

Note: Defect parts should only be replaced by original parts from the supplier. All interventions inside the housing are at one's own risk.

Note: During maintenance ensure the Remote Unit has been disconnected from mains.

Note: Before disconnecting any cables, label any unlabelled cables to ensure correct connection.

For most maintenance procedures appropriate tools are required to ensure correct handling. All these tools can be ordered from the supplier. For screwing procedures observe that all our screws have a right-hand thread, i.e. for fastening the screws turn the tool clockwise and for unscrewing them turn it counter-clockwise.

Due to the design of the Remote Unit the only component recommended to be replaced is the fan unit. For replacing any other component, please contact the supplier.

5.2. REPLACING THE FAN UNIT

Replacement of the fan unit is not required as a preventative measure. Only if an alarm indicates a malfunctioning of a fan must the unit be exchanged.

☞ **Note:** Please observe that the fan unit can only be replaced as a whole. Do not remove the fans separately.

Read the health and safety warnings in chapter 1.2 as well as the instructions in chapter 5.1 *General* before starting with the replacement.

1. **Switch off the Remote Unit. Make sure mains power is disconnected for the following replacement procedure.** Then, proceed as follows:

2. Take the protective cover off the cabinet by pulling it strongly to the front (see also chapter 3.1.2).
3. Loosen the four tallow-drop screws M4x8 of the fan guard by which the fan plate is screwed to the cabinet. Remove the four screws and the corresponding washers.

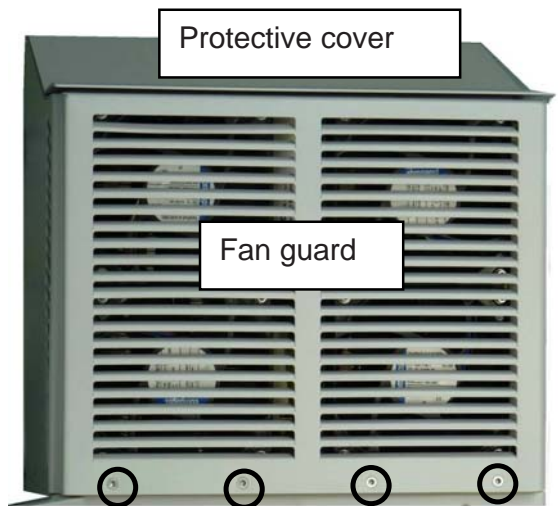

B0281A5A

Take out the entire fan plate together with all four fans.

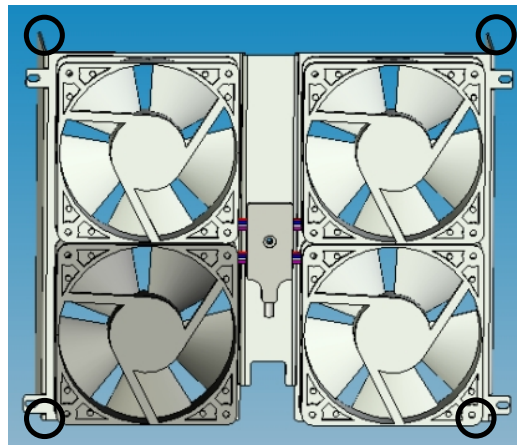

L_G3194X010

4. Remove the fan unit – by putting slight pressure on the fan plate cover – to a position that allows access to the fan connector and the earth-bonding cable.
5. Unscrew the fan connector and then disconnect the earth-bonding cable.

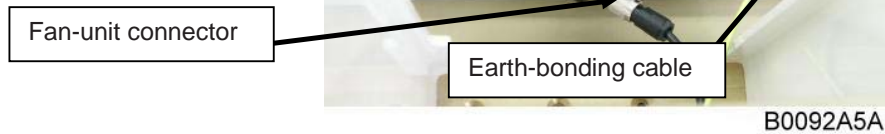

Note: To observe the specified torque of 650 Ncm for an M5 thread, use an appropriate tool for the following screwing procedures.

6. To mount the new fan unit, re-connect the earth-bonding cable and the fan connector (see *step 5*). Then, place the fan unit back into its original position and fix it tight.
7. Screw the whole fan unit to the cabinet with the four tallow-drop screws M4x8 (see *step 2*). In order not to exceed the specified torque of 330 Ncm, use an appropriate tool.
8. Put the protective cover back on the top of the cabinet (see *step 2*).

5.3. CLEANING THE HEAT SINK

👉 **Note:** Read the health and safety warnings in chapter 1.2 as well as the instructions in chapter 5.1 *General* before starting with the replacement procedure. Then, proceed as follows:

1. Switch off the Remote Unit. For the following procedure ensure to have mains disconnected before!
2. Remove the protective cover and the fan plate with the fan unit from the Remote Unit as described in chapter 5.2 *Replacing the Fan Unit*, steps 1 and 2:
3. Use compressed air (max. 5 bar) to blow out the heat sink from back to front as illustrated in the figure below:

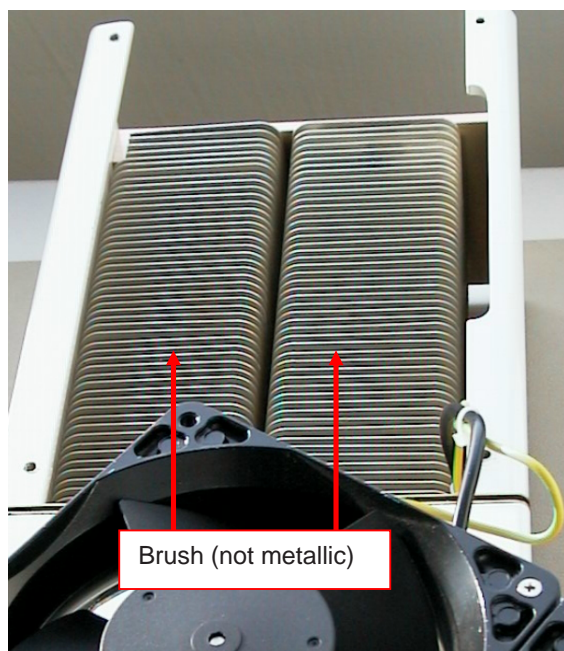

B0112A5A

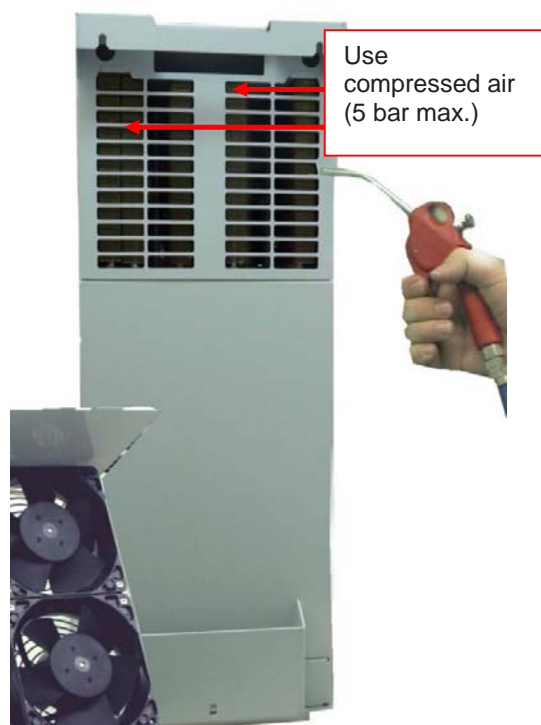

B0281AHA

4. In case the dirt cannot be blown out completely and parts of it stick to the ribs of the heat sink, clean the parts concerned carefully from the front using e.g. a brush. Take care that the material is not scratched or damaged.
5. After cleaning the heat sink, mount the fan unit and protective cover again according to chapter 5.2 *Replacing the Fan Unit*, steps 7 and 8. Then, switch the Remote Unit back on.

6. APPENDIX

6.1. ILLUSTRATIONS

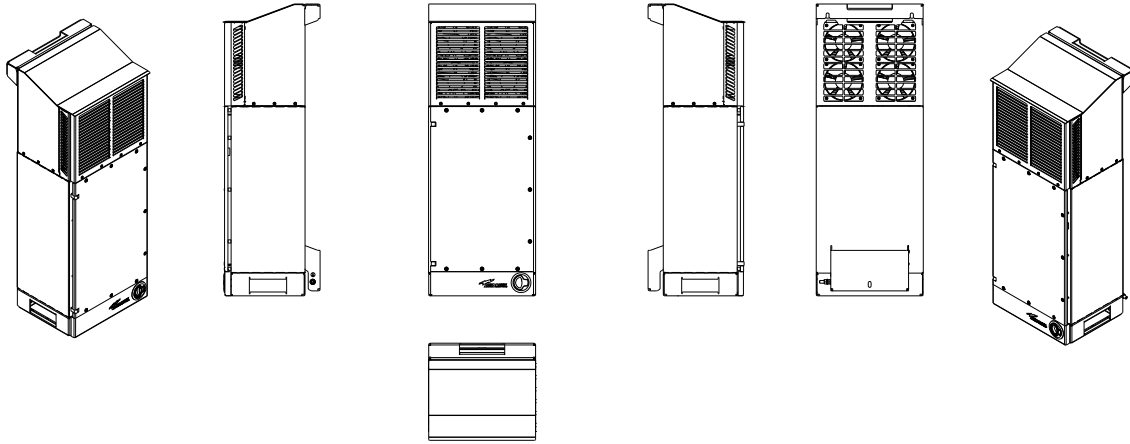

figure 6-1 Cabinet drawing

6.2. SPECIFICATIONS

6.2.1. Electrical Specifications

ION-M7P/80-85HP/9		
Electrical		
Mains power	nominal	100 Vac to 240 Vac
	operating	85 Vac to 264 Vac
Power consumption	max. temp., fully loaded	700 W
	room temp., idle	340 W
Optical Link		
Connectors	E2000/APC 8°	
Optical return loss	45 dB min.	
Fibre type	Single mode E9/125 µm	
Optical link budget	0 to 10 dB	

6.2.2. Mechanical Specifications

Height, width, depth *	1024 x 258 x 333 mm (40.3 x 10.2 x 13.1)
Weight	45,5 kg (100 lb)

* Spacing required 40 mm (1.58 in) around unit

All data is subject to change without notice.

6.2.3. Environmental and Safety Specifications

 **Note:** For detailed information, please refer to the **Environmental and Safety Specifications** leaflet of the supplier, related to ETS 300 019 (European Telecommunication Standard).

Environmental		
Operating temperature range	-33 °C to +50°C	
Ingress protection	RF part	IP66
	Fan part	IP55

All data is subject to change without notice.

6.3. SPARE PARTS

The following list contains all parts available for the Remote Unit. The configuration of the delivered unit meets the requirements of the customer and can differ depending on the state of the delivery.

Maintenance of the ION-M7P/80-85HP/9 should be performed on an FRU (Field Replaceable Unit) basis only. Do not damage the warranty labels on the components, as this voids the warranty.

If any FRU not contained in the following list needs to be replaced, please contact customer service for additional instructions.

Spare Parts List of the Remote Unit ION-M7P/80-85HP/9

Designation	ID No
<i>ION-M7P/80-85HP/9</i>	7672284
Fan Unit W-Cabinet	7619978
Wall Mounting Kit	7635354
Manual for ION-M7P/80-85HP/9	7672282-00

The manufacturer reserves the right to replace the spare parts listed above by equivalent substitutes.

☞ **Note:** Only the spare parts listed above are FRUs (= Field Replaceable Units) and can be replaced by the user. For replacement of any other parts, please send the entire Remote Unit back to the manufacturer.

7. INDEX

	7 poles.....	33
A		
Abbreviations.....		5
Alarms		
Alarm Status.....		32
Bite and Alarms.....		32
External Inputs.....		33
Handling of Alarms.....		32
List.....		35
Outputs.....		33
RU.....		35
Status LED.....		32
C		
CE Declaration of Conformity (DoC).....		9
Cleaning the Heat Sink.....		38
Commissioning		
General.....		29
CommScope.....		9
Connection Rules		
Optical-Fiber Cables.....		23
Connections		
Antenna.....		21
Connector Flange.....		19
EU with Main Unit.....		21
Mains Power AC.....		22
Power.....		22
Contact Addresses		
Customer Support.....	10, 11, 12	
Control Connector for EU.....		20
Customer Support Addresses.....	10, 11, 12	
D		
Declaration of Conformity (DoC).....		9
E		
Extension Unit		
RS485/ RS232 Control Connector (8 pins).....		20
F		
Fiber-Optical Components		
Cleaning Procedure.....		24
System Installation.....		23
Flange Connector		
5 poles.....		33
G		
Grounding.....		20
H		
Health and Safety Warnings.....		6
I		
Illustrations.....		39
Installation		
Electrical.....		18
Mechanical.....		15
M		
Maintenance.....		35
Mounting		
Wall.....		17
O		
Optical-Fibre Connection		
Protective Plug.....		25
Protective-Tube Kit.....		27
P		
Pin Assignment		
External Alarms.....		33
R		
Replacement of Fan Unit.....		36
RS485/ RS232 EU Control Connector.....		20
S		
Spare Parts.....		41
Specifications		
Electrical.....		40
Mechanical.....		40
T		
Troubleshooting.....		35

