

第1页起始位 说明书成品折叠示意图

深圳市福达斯科科技有限公司

地址：深圳市宝安区龙华大浪街道办浪口工业区盛德工业园B栋3楼
电话：0755-61116102/61116103 传真：0755-61116101

版本	V0		
产品名称	Aodelan A1说明书(尼康)	日期	2015年08月25日
型号编号	5.04.034-0001	设计/绘图	肖云强
材质	封页:128g双铜 内页:70g书纸 骑马订装,四色加一专 过哑胶	审核	
规格	成品：108*108mm	核准	
备注	封面专色PANTONE 326 C		

Wireless Flash Trigger
无线电引闪器

A₁

For Nikon

Thank you for purchasing an Aodelan product

Note: Before using the A1 TTL Flash Trigger for Nikon, please read this instruction manual carefully. Also upgrade the firmware to the latest version following the instructions provided on www.aodelan.net (To check the firmware version, please see page 17).

The A1 TTL Flash Trigger, composed of a transmitter and a receiver, is used to perform wireless flash in up to 4 groups, with each set to different flash modes (TTL/M). It supports FP high speed sync, second curtain sync, and wireless remote control of the flashes' power level and zoom level. Besides, when using a compatible radio studio light as the slave unit, the transmitter can control the studio light's modeling light.

Please Note:

1. After turning on the transmitter and receivers, slave mode does not need to be set on the flashes on receivers, but the flashes need to be set in TTL mode, A ZOOM. For operations, see the flash instruction manual.
2. Ensure there is a good hot shoe connection between the transmitter and camera, flashes and receivers for best performance.
3. Many TTL flashes have been tested but the manufacturer cannot guarantee that all third party TTL flashes will function properly with the wireless trigger. It has been designed and optimized for original Nikon flashes using the i-TTL .
4. Turn off all the devices-flashes/strobes, camera, and the transmitter and receivers when connecting and disconnecting the devices.

Warnings

- 1.This product is a precise electronic instrument. Do not expose to damp environments or dust.
- 2.Please shut down the power of all devices when installing the flash trigger.
- 3.Do not drop or crush.
- 4.Do not use the wireless trigger in flammable, explosive or high temperature environments.
- 5.Do not use harsh chemicals or solvents to clean the body. Use a soft cloth or lens paper.
- 6.Remove batteries from the wireless trigger if not being used for an extended period.
- 7.Interference: The flash trigger transmits radio signals at 2.4GHz. Its performance can be affected by electrical current, magnetic fields, radio signals, wireless routers, cellular phones, and other electronic devices. Environmental objects, such as large buildings or walls, trees, fences, or cars can also affect transmission performance. If your wireless trigger can't be triggered, move its location slightly.

FCC Interference Statement

This device complies with part 15 of the FCC Rules. Operation is subject to the following two conditions: (1) This device may not cause harmful interference, and (2) this device must accept any interference received, including interference that may cause undesired operation.

FCC Radiation Exposure Statement

This equipment complies with FCC RF radiation exposure limits set forth for an uncontrolled environment. This device and its antenna must not be co-located or operating in conjunction with any other antenna or transmitter.

FCC Class B Compliance Statement

NOTE:

This equipment has been tested and found to comply with the limits for a Class B digital device, pursuant to Part 15 of the FCC Rules. These limits are designed to provide reasonable protection against harmful interference in a residential installation. This equipment generates, uses and can radiate radio frequency energy and, if not installed and used in accordance with the instructions, may cause harmful interference to radio communications. However, there is no guarantee that interference will not occur in a particular installation. If this equipment does cause harmful interference to radio or television reception, which can be determined by turning the equipment off and on, the user is encouraged to try to correct the interference by one or more of the following measures:

- Reorient or relocate the receiving antenna.*
- Increase the separation between the equipment and receiver.*
- Connect the equipment into an outlet on a circuit different from that to which the receiver is connected.*
- Consult the dealer or an experienced radio/TV technician for help.*

Industry Canada Notice:

This device complies with RSS-210 of the Industry Canada Rules. Operation is subject to the following two conditions:

- 1. This device may not cause harmful interference, and*
- 2. This device must accept any interference received, including interference that may cause undesired operation.*

VCCI Conformity Statement:

This equipment is in the Class B category and conforms to the standards set by the Voluntary Control Council for Interference by Data Processing Equipment and Electronic Office Machines aimed at preventing radio interference in such residential areas.

When used near a radio or TV receiver, it may become the cause of radio interference, Read instruction for correct handling.

Laser Classification:

The product is classified as Class 3R laser product, according to the following standards IEC/EN 60825-1 "Radiation Safety of Laser Products."

Class 3R: A Class 3R laser is considered safe if handled carefully, with restricted beam viewing. With a class 3R laser, the MPE can be exceeded, but with a low risk of injury. Visible continuous lasers in Class 3R are limited to 5mW. For other wavelengths and for pulsed lasers, other limits apply.



Parts Transmitter

1. LED Indicator
2. LCD Screen
3. Function Button 3
4. Function Button 2
5. Function Button 1
6. <MODE>: Mode Button
7. <⚡>: Test Button
8. <⊙>: Select/Set Button
9. <⊙>: Select Dial
10. Mounting Foot Locking Lever
11. Battery Compartment
12. Function Button 4
13. Zoom/Modeling Light Function Switch Button
14. Power Button
15. Flash Exposure Confirmation Lamp
16. AF Assist Light
17. Contacts
18. Lock-release Button
19. Sync Port
20. USB Port
21. Locking Pin
22. Mounting Foot

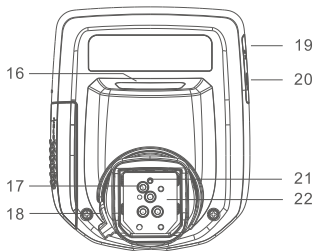
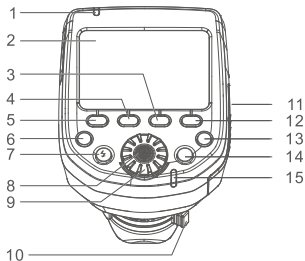

Receiver

1. LED Indicator
2. LCD Screen
3. Power Button
4. Function Button 1
5. Function Button 2
6. Function Button 3
7. Function Button 4
8. Test Button
9. Hot Shoe Mount
10. Battery Compartment
11. Cold Shoe/Tripod Lug
12. Locking Ring
13. 3.5mm Output Port
14. USB Port
15. Lanyard Slot

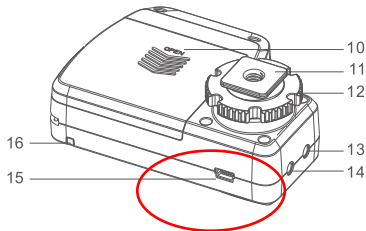
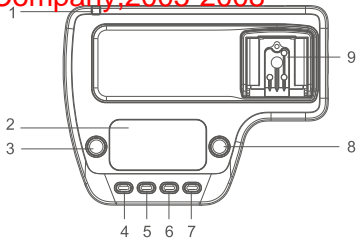

Preparation Before Use

Turn on/off the Transmitter and Receiver

1. Open the battery compartment cover as directed to insert the batteries. Make sure the "+" and "-" battery contacts are correctly oriented. (Note: Use 2 pieces of AA type alkaline or NI-MH batteries).

2. Replace the battery cover and push it back to the locked position.
3. Turn on: Press and hold the power button until the menu is displayed on screen.
4. Turn off: Press and hold the power button until the LCD screen goes black.
5. When the low power icon () is displayed on the LCD screen, replace the batteries with new ones.

Attaching the Transmitter to the Camera Hot Shoe

1. Turn off the camera and transmitter.
2. Insert the transmitter hot shoe all the way into the camera's hot shoe mount.
3. Lock the transmitter by sliding the mounting foot locking lever to the right until the locking lever clicks in place.

Lock release: Press the lock-release button while slide the lock lever all the way back to the left.

Attaching the Flash to the Receiver

1. Turn off the flash and receiver.
2. Insert the flash hot shoe all the way into the receiver's hot shoe mount.
3. Lock the flash with the flash's locking mechanism.

Detaching the flash: Release the lock of flash according to its lock release mechanism, and then slide the flash out of the receiver's hot shoe mount.

Connecting the Receiver with Studio Lights or Flashes by Cable

1. Turn off the flash/strobe and the receiver.
2. Connect a cable to the receiver's 3.5 mm output port.
3. Connect the opposite end of the cable to a flash or studio strobe.



4. Turn on the flash/strobe and the receiver.
5. Set the flash to Manual mode – no TTL functions can be used when a compatible flash is triggered by cable.





Firmware Update

The firmware of transmitter and receiver can be updated via the USB port, so as to adjust its parameter and extend its compatibility with future cameras. Any upgrades and full instructions will be announced on the AODELAN official website.

Setting the Groups, Channels and ID

1. The system supports 4 firing groups: A/B/C/D, 32 channels and 0000~9999 wireless radio IDs.
2. Receivers can be assigned group, channels and ID designations.
3. The transmitter will allow EV, Power level and Zoom level to be set for each group of receivers set the same channel and ID (unless the group is set to OFF on the transmitter).
4. Setting the Transmitter's Channel and ID

Channel: Press function button 4 to display **CH** . Press function button 1 corresponding to **CH** , turn  to set the channel. Press  button to exit the channel setting.

ID: Press function button 4 to display **ID** . Press function button 2 corresponding to **ID** , turn  to select the ID digit to be set, press  button to confirm the Selection. Turn  to set the ID value for the digit, press  to exit the setting. Repeat the above operation to set the 4 ID digits one by one.

5.Setting the Receiver's Channel, Group and ID

Channel: Press function button 1 to activate the channel setting. Press function button 2 or 3 to select the channel. Press function button 4 to exit the setting.

Group: Press function button 3 to activate the group setting. Press function button 2 or 3 to select the group. Press function button 4 to exit the setting.

ID: Press function button 2 to activate the ID setting. Press function button 1 to select the ID digit to be set. Press function button 2 or 3 to set the ID value for the digit. Repeat the above operation to set the 4 ID digits one by one. Press function button 4 to exit the setting upon completion.

Test Button on Transmitter

- 1.When the transmitter is communicating with the camera, the test flash function will be unavailable.
- 2.When the transmitter is detached from the camera, pressing the button will cause the group A/B/C/D to fire a test flash in sequence.

Test Button on Receiver

Press the test button on receiver. The flash attached to the receiver will fire a test flash.

LCD Display

Transmitter Gr Mode Screen

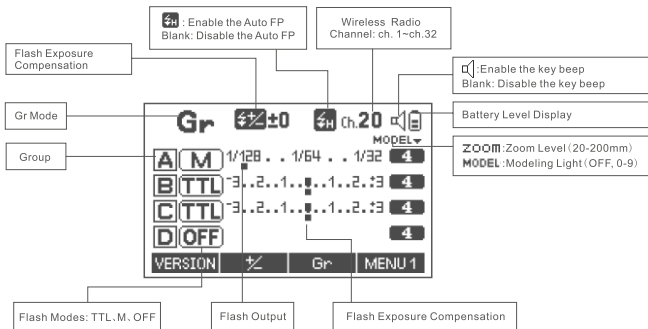

Transmitter Ratio Mode Screen

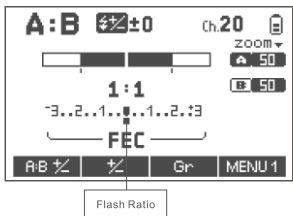

Receiver Screen

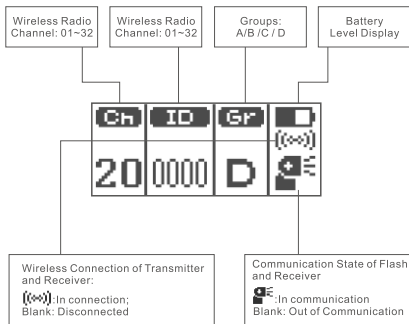

MENU Function Chart

1		Flash Exposure Compensation	±3 stops, in 1/3 stop increments
2		Custom Function	C.Fn 01, 20, 22, 24, 25 can be set
3		Personal Function	P.Fn 01,03, 08 can be set
4		Wireless Radio ID	0000~9999
5		Channel	Ch.1~Ch.32

6	MEMORY	Memory Function	SAVE	Save the current settings
			LOAD	Load the settings that were saved
				Back to shooting ready state
7	Gr	Group	A/B/C/D	
8	VERSION	Version	Base hardware, base software, and icon version	

Functions and Operations

Setting the Working Mode

The transmitter has 2 working modes: the Gr mode and the Ratio mode. Pressing the Mode button will switch between screens for the two modes.

Gr Mode

The Gr Mode will allow you to set TTL, Manual and OFF for A/B/C/D independently, along with the EV level and flash output for each group.



TTL/M/OFF

TTL: Will fire flashes using TTL metering. The EV level of each group can be adjusted within ± 3 stop in 1/3-stop increments.

Manual: Flashes are set in Manual mode and power levels adjusted within 1/1-1/128 in 1/3-stop increments.

OFF: Selecting OFF will turn off the selected group and not fire any remote flashes in the group.



Setting the flash mode and EV / Power level for each group

1. Press function button 4 to display **MENU 1**.
2. Press function button 3 corresponding to **Gr**.
3. Turn  to select the group to be set.
4. Press function button 1 to set the flash mode for the group (TTL/Manual/OFF).
5. Press function button 2, press  to set the EV level or flash output for the group.
Press  button to exit the setting.
6. Repeat steps 3-5 to set the parameter for each group one by one.

Ratio Mode

In ratio mode, you can set the flash ratio for group A and B from 8:1 to 1:8.



Setting the flash ratio

1. Press function button 4 to display **MENU 1**.
2. Press function button 1 corresponding to **A:B 1/2**, turn  to set the flash ratio from 8:1 ~1:8, in 1/2-stop increments.
3. Press  button to exit the setting.



Adjusting Flash Zoom

Press and hold the Zoom/Modeling Light Function Switch Button to display the Zoom adjustment mode. And then follow the procedures:

In Gr Mode Screen:



1. Press function button 4 to display **MENU 1**.
2. Press function button 3 corresponding to **Gr**.
3. Turn  to select the group to be set.
4. Press function button 3, turn  to change the zoom value of the group, press  button to exit the setting.

In Ratio Mode Screen

1. Press function button 4 to display **MENU 1**.
2. Press function button 3 corresponding to **Gr**.
3. Press function button 1 (group A) or 2 (group B) to select the group.
4. Turn  to change the zoom value of the group, press  button to exit the setting.

Flash Exposure Compensation (EV)

The transmitter supports setting the flash exposure compensation for all the groups (± 3 stops, in 1/3 stop increments).

1. Press function button 4 to display **MENU 1**. Press function button 2 corresponding to .
2. Or press  button to activate the exposure compensation adjustment directly.
3. Turn  to set the flash exposure compensation, press  button to exit the setting.



Setting the Modeling Light

The transmitter supports wireless control of modeling light on studio lights that are set to slave mode. The function is not available for hot shoe flashes.



1. Press and hold the Zoom/Modeling light function switch button to display the modeling light setting mode.
2. Press Zoom/Modeling light function switch button to enable (0-9) /disable (OFF) the modeling light.
3. With the modeling light enabled, you will be able to set the its brightness levels, by following the procedures:

In Gr Mode Screen

1. Press function button 4 to display **MENU 1**.

2. Press function button 3 corresponding to **Gr** .
3. Turn  to select the group to be set.
4. Press function button 3, turn  to set the brightness level for modeling light of the group. Press  button to exit the setting.

In Ratio Mode Screen

1. Press function button 4 to display **MENU 1** .
2. Press function button 3 corresponding to **Gr** .
3. Press function button 1 (group A) or 2 (group B) to select the group.
4. Turn  to set the brightness level for modeling light of the group. Press  button to exit the setting.

FP High Speed Sync

High speed sync will allow shutter speeds longer than a compatible camera specified shutter speed to be used. Shutter speed up to 1/8000 sec. can be achieved with compatible cameras and flashes.

1. FP high speed sync cannot be set on the transmitter.
2. Auto FP needs to be set on the camera. Refer to your camera manual for specific settings.

Second Curtain Sync

Second curtain sync will fire the flash at the end of an exposure, not at the beginning. This can be combined with longer exposures for creative effects.

1. Second curtain sync cannot be set on the transmitter.
2. Second curtain sync needs to be set on the camera. Refer to your camera manual for specific settings.

Continuous High Speed Shooting

Using the flash trigger will result in slower continuous high speed shooting than can be achieved when using a flash directly on the camera. There are differences in metering between the A1 flash trigger system related to groups and the pre-flashes than Nikon's native system.

1. Continuous high speed shooting function cannot be set on the transmitter.
2. Continuous high speed shooting function needs to be set on camera. Refer to your camera manual for specific menu settings.

AF Assist Light

In low light/contrast situation, you can enable the AF assist light on transmitter by setting personal function. The transmitter's built-in Auto Focus Assist Light will illuminate to assist with AF. You can disable the function when it is not needed.

 Note: The laser AF assist light is safe with optical power less than 5mW. Please avoid pointing the light at human eyes.

LCD Backlight (Illumination)

1. The LCD backlight features of transmitter can be set in the custom function (C.Fn22) and personal function (P.Fn 03).
2. The backlight will light up for 8 seconds when pressing any button on the receiver and then go off if no buttons are pressed.

LED Indicators

When the transmitter and receiver are left idle, the LED indicators on transmitter and receiver will blink in green. When the camera is focusing, the indicators will light green. When taking photos, the LED indicators will light red.

Exposure Confirmation Indicator

During wireless shooting, if a standard flash exposure was obtained, the flash exposure confirmation lamp will light blue for 3secs.

Memory Function

The transmitter has memory function. You can save the wireless settings and recall the settings later.

1.Press function button 4 to display **MENU 3** .

2.Save or load the settings

Press function button 3 corresponding to **MEMORY** , and then press function button 1 corresponding to **SAVE** , the settings will be saved (stored in the memory). Press function button 2 corresponding to **LOAD** , the settings that were saved will be set.

Clearing the Settings

1.Transmitter: Press the function button 2 and 3 for 2s simultaneously. Note that even when the settings are cleared, the transmission channel, the wireless ID, the C.Fn and P. Fn settings are not canceled.

2.Receiver: Press and hold power button and function button 2 simultaneously.

Checking the Firmware Version

Transmitter: In Gr Mode, press function button 4 to display **MENU 1** . Press function button 1 corresponding to **VERSION** , the firmware info will be displayed on the LCD screen.

Receiver: While pressing and holding the power button to turn on the receiver, press the function button 1 or 3 simultaneously until firmware version is displayed. The function button 1 and 3 respectively correspond to the basic firmware version and icon version of the receiver.

ODS Functions

When shooting with a strobe light (IGBT controlled light in particular) in HSS mode, adjusting the ODS value properly will in some way help with a high speed sync issue. You can set the ODS value in the custom function.





The ODS function's performance varies with camera models, working modes and the flash duration times of strobes. Under certain circumstances, it may not work well or even do not take effect at all.

Note:

1. Only use the ODS function for irregular situation. Set it to default when not using the function.
2. When the shooting conditions are changed, reset the ODS value.

C.Fn: Custom Function

The transmitter comes with a number of programmable custom functions. To edit those functions, see below:

1. Press function button 4 to display **MENU 3**.
2. Press and hold function button 1 corresponding to **C.Fn**, until the custom function screen is displayed.
3. Turn  to select an item to set and press  button.
4. Turn  to select the setting and press  button to exit the setting.
5. Press function button 4 corresponding to  to exit the custom function setting screen.
6. To set all the custom function settings to default: when custom function setting screen is displayed, press function button 2 corresponding to **CLEAR** and then press function button 2 corresponding to **OK**. Press function button 4 corresponding to **CANCEL** will cancel the operation.

Custom Function Chart

Custom Function No.	Functions	Setting No.	Setting and Descriptions
C.Fn 01	Auto IDLE	0: ON	Enable Auto IDLE when the transmitter is not operated for 5 min.
		1: OFF	Disable the Auto IDLE.
C.Fn 20	Key Beep	0: OFF	Disable key beep to sound on transmitter.
		1: ON	Enable key beep to sound on transmitter
C.Fn 22	LCD Panel Illumination	0: 12sec	When a button or dial is operated, the LCD panel illumination will go on for 12 sec.
		1: OFF	Disable LCE panel illumination
		2: ON	When a button or dial is operated, the LCD illuminates and keeps always on.
C.Fn 24	ODS Function	0.0~5.0ms	Delay time for high speed sync
C.Fn 25	TTL Preference	/	± 3stops, in 1/3-stop increments

P.Fn: Personal Function

The transmitter comes with a number of programmable personal functions. To edit those functions, see below:

1. When custom function setting screen is displayed, press function button 1 corresponding to **P.Fn**. The personal function setting screen will be displayed.
2. Set the personal functions in the same way as step 3~5 for the custom function.

3.To set the personal function to default: set it in the same way as step 6 for custom function.

Personal Function Chart

Personal Function No.	Functions	Setting No.	Setting and Descriptions
P.Fn 01	LCD Panel Display Contrast		You can adjust the contrast of LCD panel in 5 levels.
P.Fn 03	LCD Panel Illumination Color	0: GREEN	Select green as the color of LCD panel illumination.
		1: ORANGE	Select orange as the color of LCD panel illumination.
P.Fn 08	AF Assist Light	0: ENABLE	Enable the AF assist light.
		1: DISABLE	Disable the AF assist light.

Specification

Type	On-Camera Flash Wireless Trigger
Exposure Control System	TTL, Manual
Frequency	2.4GHz
Channels	Ch1~Ch32
Wireless Radio ID	0000~9999
Groups	A/B/C/D
Distance	100m+
Flash Ratio	1:8-1:1-8:1

Flash Exposure Compensation	±3 stops in 1/3-stop increments
Auto FP	Provided
Manual Output	1/1~1/128(1/3-stop increment)
Flash Exposure Confirmation	Flash exposure confirmation indicator lights up
Modeling Light	OFF,0~9 Brightness Level adjustment
AF Assist Light	Peak wavelength: 650nm; Optical power: <5mW
Power Supply	2 X AA type alkaline or NI-MH batteries(TX and RX); 5V DC on receiver(external power port)
Power Saving	Auto Idle if not operated for 5 min(transmitter)
Dimension	L84*W68*H56mm(TX) ; L93*W70*H48mm(RX)
Net Weight(approx.)	121g(TX) ; 95g(RX)

Note: Product specifications and external design are subject to change without further notice.

*For compatible camera and flashes.

Warranty Terms:

1. In case of product malfunctions, the Three Guarantees service (for refunding, free repair, replacement) will be available on condition that customer provides valid purchase invoice and the Three Guarantees certificate (the Three Guarantee certificate should be filled by customer in the purchase and sealed by the dealer for it to take effect).
2. The main unit of product comes with a 1 year warranty from the date of purchase.
3. New firmware will be available for download on aodelan.net. Customer can look for firmware upgrades on the website.
4. For other terms, please refer to details of the Three Guarantees policy.

The Warranty Does Not Apply to:

1. Failure to provide invoice, the Three Guarantee certificate, and other proof to prove that the product is within warranty time of the Three Guarantee service.
2. The main unit, invoice or the content of the Three Guarantees certificate is inconsistent with the physical goods or has been altered.
3. The main unit and accessories had been subject to abnormal usage or misuse. Abnormal situations include but not limited to: improper storage, unauthorized demolition or alteration, improper installation and damages due to elements not caused by the product itself.
4. Damage caused by misuses such as water or external force damage and etc.
5. Damage caused by improper usage, maintenance or transportation in failure to follow the product's manual instructions.